

AD 731 625



AD

AMMRC CR 71-2/2

THE EFFECTS OF SURFACE LAYER ON PLASTIC DEFORMATION
AND CRACK PROPAGATION

August 1971

I. R. Kramer and A. Kumar
Martin Marietta Corporation
P. O. Box 179, Denver, Colorado 80201

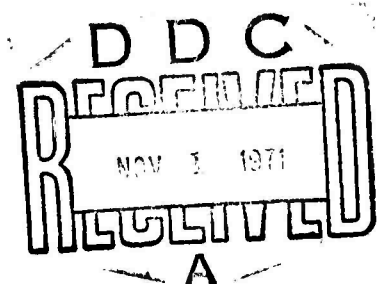

Semiannual Report

Contract DAAG 46-70-C-0102

Approved for public release; distribution unlimited

Prepared for

Reproduced by
**NATIONAL TECHNICAL
INFORMATION SERVICE**
Springfield, Va. 22151

ARMY MATERIALS AND MECHANICS RESEARCH CENTER
Watertown, Massachusetts 02172

20

DOCUMENT CONTROL DATA - R & D

(Security classification of title, body of abstract and indexing annotation must be entered when the overall report is classified)

| | | | |
|--|---|---|--|
| 1. ORIGINATING ACTIVITY (Corporate author) Martin Marietta Corporation | | 2a. REPORT SECURITY CLASSIFICATION Unclassified | |
| | | 2b. GROUP | |
| 3. REPORT TITLE The Effects of Surface Layer on Plastic Deformation and Crack Propagation | | | |
| 4. DESCRIPTIVE NOTES (Type of report and inclusive dates) Semiannual Report to | | | |
| 5. AUTHOR(S) (First name, middle initial, last name) I. R. Kramer and A. Kumar | | | |
| 5. REPORT DATE August 1971 | 7a. TOTAL NO. OF PAGES 59 | 7b. NO. OF REFS 22 | |
| 8a. CONTRACT OR GRANT NO. DAAG 46-70-C-0102 | 8b. ORIGINATOR'S REPORT NUMBER(S) AMMRC CR 71-2/2 | | |
| a. PROJECT NO. ARPA Order 180-0-7400 | 8c. OTHER REPORT NO(S) (Any other numbers that may be assigned this report) | | |
| 10. DISTRIBUTION STATEMENT Approved for public release; distribution unlimited. | | | |
| 11. SUPPLEMENTARY NOTES | | 12. SPONSORING MILITARY ACTIVITY Army Materials and Mechanics Research Cent. Watertown, Massachusetts 02172 | |
| 13. ABSTRACT <p>The rate of crack propagation was measured in three materials -- aluminum 2014-T6, titanium (6Al-4V), and 4130 steel. Cyclic loading tests were performed at room temperature with the ratio of minimum to maximum stress intensity $K_{min}/K_{max} = 0.25$. Center-cracked and Rippling specimens were used for plane stress testing while compact tension (CT) specimens were used for plane strain testing. The effect of prestress and surface layer elimination treatment was investigated. A significant reduction in the crack propagation rate was observed with this treatment. The improvement was maximum at low stress intensity values both in plane stress and plane strain conditions. The optimum improvement was observed in specimens that were prestressed just below the yield and the surface removed.</p> | | | |

| 14. KEY WORDS | LINK A | | LINK B | | LINK C | |
|---|--------|----|--------|----|--------|----|
| | ROLE | WT | ROLE | WT | ROLE | WT |
| Crack Propagation Stress Intensity Crack Growth Surface Layer Fatigue | | | | | | |

ACCESSION FOR

CFSTI

DDC

UNCLASSIFIED

DATE

BY

AVAILABILITY CODES

ATTN: 004 OF SPECIAL

WHITE SECTION

BUFF SECTION

A

The findings in this report are not to be construed as an official Department of the Army position, unless so designated by other authorized documents.

Mention of any trade names or manufacturers in this report shall not be construed as advertising nor as an official indorsement or approval of such products or companies by the United States Government.

DISPOSITION INSTRUCTIONS

Destroy this report when it is no longer needed.
Do not return it to the originator.

AMMCR CR 71-2/2

THE EFFECTS OF SURFACE LAYER ON PLASTIC DEFORMATION
AND CRACK PROPAGATION

I. R. Kramer and A. Kumar
Martin Marietta Corporation, Denver Division
P. O. Box 179, Denver, Colorado 80201

August 1971

Semi-Annual Report

DAAG 46-70-C-0102

ARPA-Order 180-0-7400

Approved for public release; distribution unlimited

Prepared for

ARMY MATERIALS AND MECHANICS RESEARCH CENTER
Watertown, Massachusetts 02172

FOREWORD

This report was prepared by the Denver Division of Martin Marietta Corporation under U. S. Army Contract DAAG 46-70-C-0102. The contract is sponsored by the Advanced Research Project Agency under ARPA Order 188-0-7400 and is being administered by the Army Materials and Mechanics Research Center, Watertown, Massachusetts, with Dr. Eric B. Kula, AMXMR-RM, serving as Technical Supervisor.

ABSTRACT

The rate of crack propagation was measured in three materials -- aluminum 2014-T6, titanium (6Al-4V), and 4130 steel. Cyclic loading tests were performed at room temperature with the ratio of minimum to maximum stress intensity $K_{\min}/K_{\max} = 0.25$. Center-cracked and Rippling specimens were used for plane stress testing while compact tension (CT) specimens were used for plane strain testing. The effect of prestress and surface layer elimination treatment was investigated. A significant reduction in the crack propagation rate was observed with this treatment. The improvement was maximum at low stress intensity values both in plane stress and plane strain conditions. The optimum improvement was observed in specimens that were prestressed just below the yield and the surface removed.

CONTENTS

| | <u>Page</u> |
|---|-------------------|
| Foreword | ii |
| Abstract | iii |
| Contents | iv thru vii |
| I. Introduction | 1 |
| II. Experimental Techniques | 8 |
| A. Specimen Preparation and Heat Treatment | 8 |
| B. Specimen Configuration | 12 |
| C. Testing | 16 |
| III. Experimental Results | 17 |
| A. Plane Stress Testing | 18 |
| B. Plane Strain Testing | 40 |
| IV. Discussion of Results | 48 |
| V. Summary | 57 |
| VI. References | 58 and 59 |
| <u>Figure</u> | |
| II-1 Microstructure of (a) 0.125-Inch-Thick and (b) 1.000-Inch-Thick Aluminum 2014-T6 | 9 |
| II-2 Microstructure of (a) 0.067-Inch-Thick and (b) 0.625-Inch-Thick Titanium (6Al-4V) | 10 |
| II-3 Microstructure of (a) 0.125-Inch-Thick and (b) 0.625-Inch-Thick Steel 4130 | 11 |
| II-4 Center-Cracked Specimen | 13 |
| II-5 Proportions of Modified Compact Tension Specimen | 14 |
| II-6 Rippling Type M-4 Test Specimen | 15 |
| III-1 Effect of Prestress and Surface Removal on the Crack Propagation Rate of Titanium (6Al-4V) under Plane Stress Conditions, Center-Cracked Specimens 0.067-Inch Thick | 19 |
| III-2 Crack Propagation Behavior of Titanium (6Al-4V) under Plane Stress Conditions, Center-Cracked Specimens 0.067-Inch Thick | 20 |

| | | |
|--------|---|----|
| III-3 | The Effect of Prestress and Surface Removal on the Crack Propagation Rate of Titanium (6Al-4V) under Plane Stress Conditions, Center-Cracked Specimens 0.067-Inch-Thick | 22 |
| III-4 | Crack Propagation Behavior of Titanium (6Al-4V) under Plane Stress Conditions, Center-Cracked Specimens 0.067-Inch-Thick | 23 |
| III-5 | Crack Growth Behavior of Titanium (6Al-4V) under Plane Stress Conditions, Center-Cracked Specimens 0.067-Inch-Thick | 24 |
| III-6 | Crack Growth Behavior of Titanium (6Al-4V) under Plane Stress Conditions, Center-Notched Specimen 0.067-Inch-Thick | 25 |
| III-7 | The Effect of Prestress and Surface Removal on the Crack Growth Rate of Titanium (6Al-4V) under Plane Stress Conditions, Center-Notched Specimens 0.067-Inch-Thick | 26 |
| III-8 | Crack Propagation Behavior of 4130 Steel under Plane Stress Conditions, Center-Cracked Specimens 0.067-Inch Thick | 28 |
| III-9 | Crack Propagation Behavior of 4130 Steel under Plane Stress Conditions, Center-Cracked Specimens 0.125-Inch Thick | 29 |
| III-10 | Crack Propagation Behavior of 4130 Steel under Plane Stress Conditions, Center-Cracked Specimens 0.125-Inch Thick | 30 |
| III-11 | Crack Propagation Behavior of 4130 Steel under Plane Stress Conditions, Center-Cracked Specimens 0.125-Inch Thick | 31 |
| III-12 | Crack Propagation Behavior of 4130 Steel under Plane Stress Conditions, Center-Cracked Specimens 0.125-Inch Thick | 32 |
| III-13 | Crack Propagation Behavior of 4130 Steel under Plane Stress Conditions, Center-Cracked Specimens 0.125-Inch Thick | 33 |
| III-14 | Crack Propagation Behavior of 2014-T6 Aluminum under Plane Stress Conditions, Center-Cracked Specimens 0.125-Inch Thick | 35 |
| III-15 | Crack Propagation Behavior of 2014-T6 Aluminum under Plane Stress Conditions, Center-Cracked Specimens 0.125-Inch Thick | 36 |

| | | |
|--------|--|----|
| III-16 | Crack Propagation Behavior of 2014-T6 Aluminum under Plane Stress Conditions, Center-Cracked Specimens 0.125-Inch Thick | 37 |
| III-17 | Rippling (6Al-4V) Specimen Showing Veering Off the Crack Front | 38 |
| III-18 | Crack Propagation Behavior of Al 2014-T6 under Plane Stress Condition, Rippling Specimen 0.125-Inch-Thick | 39 |
| III-19 | Crack Propagation Behavior of Aluminum 2014-T6 under Plane Strain Conditions, CT Specimens 1-Inch Thick | 41 |
| III-20 | Crack Propagation Behavior of Aluminum 2014-T6 under Plane Strain Conditions, CT Specimens 1-Inch Thick | 42 |
| III-21 | Crack Propagation of Titanium (6Al-4V) under Plane Strain Conditions, CT Specimens 0.64-Inch Thick | 43 |
| III-22 | Crack Propagation of Titanium (6Al-4V) under Plane Strain Conditions, CT Specimens 0.64-Inch Thick | 44 |
| III-23 | Effect of Prestress and Surface Layer Elimination on the Crack Propagation Rate of 4130 Steel under Plane Strain Condition, Compact Tension Specimens 0.625-Inch Thick | 46 |
| III-24 | Crack Propagation Behavior of 4130 Steel, CT Specimens 0.625-Inch Thick | 47 |
| IV-1 | Effect of Removal of Surface Layer on Fatigue-Life of Titanium | 49 |
| IV-2 | Effect of Removal of Surface Layer on the Fatigue Life of 7075-T6 Aluminum, Tested in Tension-Compression | 50 |
| IV-3 | Crack Propagation Behavior of 4130 Steel under Plane Strain Condition, CT Specimens 0.625-Inch Thick | 52 |
| IV-4 | The Effect of Prestress and Surface Removal Treatment on Crack Propagation Behavior of Titanium (6Al-4V) under Plane Strain Conditions in Methanol-Chloride Environment, Center-Crack Specimens 0.067-Inch Thick | 54 |

| | | |
|--------------|--|----|
| IV-5 | Electron Fractographs of (a) Untreated and (b) S-SLE-Treated Titanium (6Al-4V), Specimens Tested in Air under Plane Stress Conditions . . . | 55 |
| IV-6 | Electron Fractograph of (a) Untreated and (b) S-SLE-Treated Aluminum 2014-T6 Specimens Tested in Air under Plane Strain Conditions | 56 |
| <u>Table</u> | | |
| II-1 | Mechanical Properties of the Alloys | 8 |
| IV-1 | Summary of Crack Propagation Data for Materials . | 51 |

I. INTRODUCTION

The objective of the work described in this report was to investigate the effect of surface layer on the rate of crack propagation. Based on this knowledge we propose to improve the crack propagation resistance of structural metals. We have previously shown that prestressing followed by surface removal increases the endurance limit of metals. Under this contract we are measuring the effect of prestress and surface layer elimination (S-SLE) treatment on the rate of crack propagation in three materials -- titanium (6Al-4V), aluminum 2014-T6, and 4130 steel - under plane stress and plane strain conditions.

Fracture mechanics technology has developed rapidly over the past 10 years. The goal of fracture mechanics is to provide a quantitative measure of a material's resistance to crack propagation. The basis for fracture mechanics is the fact that all structures have flaws. Although the flaw size may be too small to detect or too small to affect the strength of the structure, a flaw can grow in size under repeated loading or under sustained loading, particularly in a corrosive environment. Since structural weight is a critical problem, designers have approached increased design allowables through the use of newer high-strength materials. However, many high-strength materials tend to be brittle and have lower fracture toughness, which means that the material is less tolerant of flaws. In thin specimens the failure can be characterized by large amounts of plastic deformation, more nearly a plane stress condition. However, as the thickness is increased, plane strain conditions are approached, and the failure is characterized by only small, if any, yielding. The mathematical strength of a singularity such as a crack is designated as the stress intensity factor K . For example the stress intensity factor K for an elliptical crack of length $2a$ in an infinite sheet subjected to uniformly distributed stress σ is given by $\sigma\sqrt{\pi a}$. Unstable fracture occurs when K reaches a critical value designated K_c . The fracture toughness K_c decreases as specimen thickness is increased and can reach a minimum value. The minimum value of K_c is labeled K_{Ic} and corresponds to a completely square fracture suggesting that fracture was accompanied by very little plastic deformation. For thin specimens, the stress state is more nearly plane stress.

Another important consideration is that flaw growth can result from cyclic loading or from sustained loading in a hostile environment. Data from fracture tests then must be obtained to predict the number of cycles required for the initial flaw to grow to a critical size. In the present work we have measured the effect of prestress and surface removal treatment on the rate of crack propagation in metals. The evidence that surface layer affects the crack propagation rate may be obtained from the measurements of surface layer stress, cyclic hardening, and fatigue under vacuum and corrosive environments.

When a metal is deformed, the surface region work-hardens to a greater extent than the bulk. This can be shown as discussed in the following paragraphs.

If a specimen is deformed plastically and unloaded and then immediately deformed again, plastic flow starts at the unloading stress. However, if an amount of material is removed, say, electrochemically, the specimen starts to yield at a lower stress. The difference between the unloading stress, $\Delta\sigma$, and the initial flow stress upon reloading increases with the amount of metal removed, Δx , until a given value Δx is reached. Thereafter it remains constant. The maximum $\Delta\sigma$ is defined as the surface layer stress, σ_s . The difference in the true stress attributed to surface removal is defined as the surface layer stress. The thickness of the surface layer corresponds to the knee of the $\Delta\sigma - \Delta x$ curve.

The surface layer forms as a result of a trapping of dislocations as they attempt to egress from the specimens. From the observations that a surface layer is formed in gold, it appears that an oxide film is not required for surface layer formation. However, any film that impedes the egress of dislocations will enhance the formation of the surface layer.

It is generally considered that the net stress σ^* acting on the dislocations is given by

$$\sigma^* = \sigma_a - \sigma_b \quad [1]$$

where σ_a is the applied stress and σ_b is the back stress. However, because of the existence of the surface layer,

$$\sigma_b = \sigma_o + \sigma_i + \sigma_s \quad [2]$$

where

σ_0 is a constant usually taken as the proportional limit,

σ_1 is the back stress due to dislocations generated in the bulk during plastic deformation,

and σ_s is the resistive stress associated with the presence of surface layer.

In Equation [2], the surface layer stress is given as $\sigma_s = \frac{\Delta L}{A_0}$ where ΔL is the difference between the flow load after removal of the surface layer and the initial load and A_0 is the cross-sectional area of the specimen.

It is apparent that the surface layer imposes a back stress that impedes the motion of dislocations and increases the flow stress needed to attain a given strain. The value of this back stress, which we have defined as the surface layer stress is, as previously mentioned, the difference between the unloading stress and the initial flow stress after eliminating the surface layer. Values for the surface layer stress have been obtained for single crystals of aluminum and polycrystalline copper, gold, aluminum, iron, molybdenum, titanium (6Al/4V), and the aluminum alloy 7075-T6. In all cases the surface layer stress, σ_s , increases with strain, ϵ ,

$$\sigma_s = C_s \epsilon^n \quad [3]$$

where C_s is a constant and n is a work-hardening exponent equal to that found in the similar relationships involving the applied stress and strain.

We have previously conducted a number of experiments to gain an understanding of the nature of the surface layer. Measurements of activation energy and the activation volume (or the product of activation area and Burger's vector) show that the surface layer contains a higher concentration of dislocations and other obstacles to plastic flow than the bulk (1,2,3).*

It is generally accepted that for face-centered cubic metals, activation volume, V^* , gives a measure of the dislocation density, ρ , and for a simple square array $V^* \propto \frac{1}{\sqrt{\rho}}$ (4). The activation volume data obtained for aluminum single crystals while the surface layer was being continuously removed by electrochemical polishing show that the activation volume, reported as $\beta = V^*/kT$, increases as the rate of removal increases. This behavior is to be expected if the surface layer contains a higher dislocation concentration than the bulk. An increase in the activation volume is also noted when the surface layer is removed by relaxation. Additional evidence of a "hard" surface layer may be found in the measurements of the apparent activation energy of aluminum single crystals, copper, and gold (5) as a function of the rate of metal removal. The data for aluminum, copper, and gold show that the apparent activation energy decreases as the rate of metal removal increases. These measurements were obtained by quickly changing the temperature during creep while the specimen was being polished at a constant rate. The apparent activation energy, U , may be expressed as

$$U = U_0 - V^*\tau^* \quad [4]$$

where U_0 is the activation energy in the absence of the net shear stress, τ^* . The decrease in U with increasing rate of metal removal must be due to the increase in the $V^*\tau^*$ term. In fact, it has been shown that the change in $V^*\tau^*$ value with the rate of removal of the metal accurately accounts for the decrease in the apparent activation energy (5).

Attempts to measure the dislocation density by etch pit and thin film electron microscopic techniques have been made (6,7,8,9,10). Kitajima (6) has reported that the dislocation density of strained copper single crystals was highest at the surface, and the density decreased to a constant value after a depth of about 50 or 100 microns (0.002 to 0.004 in.). Suzuki (7) reported a surface layer of about 50 microns in deformed KCl crystals. These values agree with those obtained by measuring the surface layer stress. Vellaikal and Washburn (8) also reported that in polycrystalline copper plastic, flow occurred first in the surface grains and then in the bulk. In contrast, Block and Johnson (9), ostensibly using the same technique as Kitajima, reported that the dislocation density was uniform

*References may be found in Chapter VI.

throughout the cross section of strained copper crystals. Fourie (10) deformed copper crystals and, by an electrochemical jet technique, cut out specimens 0.003-in. thick. He reported that the outer portions of the strained specimen were softer than that of the bulk. These data would imply that the initial flow stress would be above the unloading stress for specimens that are deformed and the surface layer removed. The data would also imply that the activation energy would increase and the activation volume would decrease when the measurements were taken under continual metal removal conditions. These implications are contrary to the experimental data on activation parameters. In some materials such as titanium (6Al-4V), the surface layer is unstable and the surface layer stress relaxes with time even at low temperatures. In some other materials such as aluminum 7075-T6, the dislocations in the surface layer are strongly pinned; consequently, the surface layer stress does not decrease with time (11). Experiments are therefore needed to determine the stability of surface layer. The rate of relaxation of the surface layer stress may be measured by determining the change, as a function of time, of the difference between the unloading stress and the initial flow stress on reloading. We have found that the value of the surface layer stress after complete relaxation was equal to that measured by the surface removal method. Further, it was noted that during the relaxation period the length of the specimen changed in a direction opposite to that of the initial strain; i.e., when the specimen was pulled in tension, it shortened during relaxation and lengthened when the initial strain was compressive. These observations indicate that an excessive amount of dislocations of one sign is present in the surface layer. An interesting observation concerning relaxation of the surface layer is that, on reloading after eliminating the surface layer only, the stress-strain curve always joins that of the extension of the original stress-strain curve. If, however, the temperature is sufficiently high to cause relaxation in the bulk material, the stress-strain curve on reloading falls below the extension of the initial portion of the stress-strain curve. This relaxation behavior is the same as that for ortho and meta recovery reported by Cherian *et al.* (12). Our results show the surface layer relaxes completely in high-purity aluminum in about four hours and in approximately one hour and 50 hours for titanium (6Al/4V) and OFHC copper, respectively.

It has been firmly established that environment has a very large effect on the mechanical behavior of metals. The decrease in "hardness" or the increase in creep rate of metals deformed in surface active agents (13) (Rehbinder effect), the increase in the fatigue life of metals at low ambient pressures (14), and the

increase in the creep rate and extent of Stage I, II, and III of metals deformed in vacuum (15) are several examples of environmental effects. The effect of specific hostile environments on fatigue and stress corrosion cracking and increased crack propagation rates are well known (16).

Early attempts to explain these environmental effects on plastic flow were based on dislocation source mechanisms. The environment was considered to affect either surface sources or near-surface sources. However, a surface source explanation does not appear to be fruitful, principally because the environment influences the plastic behavior over a very large range of strains. At large strains, dislocation behavior is governed by velocity considerations and multiplication by "mushrooming" rather than dislocation source mechanisms. It appears to be useful to describe the influence of environment in terms of the surface layer.

The formation of the surface layer seems to be sensitive to the environment in which specimens are deformed. In keeping with the observation that the flow stress of aluminum is lower for specimens deformed in vacuum than in air, the surface layer stress is lower for specimens strained in vacuum compared to those strained in air. This implies the density of obstacles in the surface layer is less. Apparently, in confirmation the activation volume is larger, and the apparent activation energy is decreased when specimens are deformed in vacuum (5). The rate of relaxation of the surface layer stress is also increased when the straining and relaxation is conducted at reduced pressures. These data were obtained by straining polycrystalline specimens 0.15 inch in diameter and measuring the change in the surface layer stress as a function of time while the specimens remained in the evacuated test chamber. It is believed that the decrease in the surface layer stress and the increased rate of relaxation is associated with the decrease in the oxide layer on the slip steps. During the deformation process, the oxide coating is ruptured continuously, and the emerging slip step is momentarily free of oxide. The rate at which it is reoxidized will, of course, depend on the partial pressure of such active species as oxygen and water vapor. It is suggested that this condition allows a more rapid egress of dislocations as they move along the operative slip planes with the result that less of a surface layer is formed in vacuum. By the same mechanism, the rate of relaxation of the surface layer would be expected to be more rapid in vacuum.

It appears that the media that cause stress corrosion cracking (SCC) also considerably influence the surface layer stress and its rate of relaxation. We have measured the surface layer stress for copper deformed in cupric nitrate-ammonium hydroxide, and for titanium (6Al/4V) deformed in methanol-hydrochloric acid. The copper-ammonium hydroxide solution is known to cause stress-corrosion cracking in brass but not in copper (17,18). For both copper and the titanium (6Al/4V) alloy, at strains below approximately 10^{-2} the surface layer stress markedly increased when the specimens were deformed in the appropriate stress-corrosion medium. In the tests of copper conducted at a strain of 0.001, the surface layer stress increased from 400 to 1100 psi. With increasing strain the surface layer stress increased slowly and, above 0.01, the values were the same as those obtained in air and in the copper-ammonium hydroxide solution. Similar results were noted when the titanium alloy was tested in the methanol-hydrochloric acid solution at strain rates of 5×10^{-4} seconds⁻¹ and 10^{-4} seconds⁻¹. In this case above strains of 0.005 and 0.01 for strain rates of 5×10^{-4} and 10^{-4} seconds⁻¹, the surface layer stresses were the same as those obtained in air. These data also indicate that the surface layer stress increased as the strain rate decreased. Since it is well known that stress-corrosion cracking is affected by the strain rate and increases with decreasing strain rate, the observation that, for strains larger than about 10^{-2} , the surface layer stress for copper and the titanium alloys is the same in air and the stress-corrosion media is of interest. These data imply that a film formed as a result of the reaction between the media and the specimen strongly impedes the egress of dislocations. At strains greater than about 10^{-2} , this film is broken and the dislocations may move more easily through the surface.

Relaxation of the surface layer stress is also sensitive to the environment. The surface layer in copper is completely relaxed in air in about 50 hours, while in the stress-corrosion cracking medium, the time required is about 1000 hours. For titanium, complete relaxation occurs in one hour in air and in 1500 hours in the methanol solution.

II. EXPERIMENTAL TECHNIQUES

The following tabulation shows the materials that were procured from the vendors.

| Material | Thickness (in.) | Vendor |
|-------------------|-----------------|------------|
| Aluminum 2014-T6 | 0.125 | Alcoa |
| Aluminum 2014-T6 | 1.0 | Kaiser |
| Titanium (6Al-4V) | 0.067 | Timet |
| Titanium (6Al-4V) | 0.625 | Timet |
| 4130 Steel | 0.125 | U.S. Steel |
| 4130 Steel | 0.625 | U.S. Steel |

A. SPECIMEN PREPARATION AND HEAT TREATMENT

The specimens were machined from sheet or plate stock in the "as-received" condition and then subjected to stress-relieved treatment to eliminate the residual stress imparted by the machining operation. A 250°F one-hour treatment was used for the aluminum specimens and the titanium (6Al-4V) was annealed at 1300°F for an hour in a vacuum furnace. The 4130 steel was austenitized at 1650°F for one hour, oil quenched, and tempered at 800°F for one hour. For the specimens that were to be given the prestress and surface layer removal treatment, prestressing was done on specimen blanks before machining the final specimens. The notches were machined in after the prestress and surface layer removal treatment. It has been shown previously that the surface layer can be eliminated by chem-milling or by a relaxation treatment. These treatments have been designated by SLE-C or by SLE-R, representing chem-milling and relaxation respectively. When chem-milling was used, 0.005-inch was removed from each surface. The mechanical properties of the heat-treated materials are shown in Table II-1.

Table II-1 Mechanical Properties of the Alloys

| Material | Proportional Limit (ksi) | Yield Strength 0.2% Plastic Strain |
|-------------------|--------------------------|------------------------------------|
| Aluminum 2014-T6 | 56 | 69 ksi |
| Titanium (6Al-4V) | 124 | 130 ksi |
| 4130 Steel | 163 | 175 ksi |



(a) Aluminum 2014-T6, 500X



(b) Aluminum 2014-T6, 500X

Fig. II-1 Microstructure of (a) 0.125-Inch-Thick and
(b) 1.000-Inch-Thick Aluminum 2014-T6



(a) Ti(6Al-4V), 500X

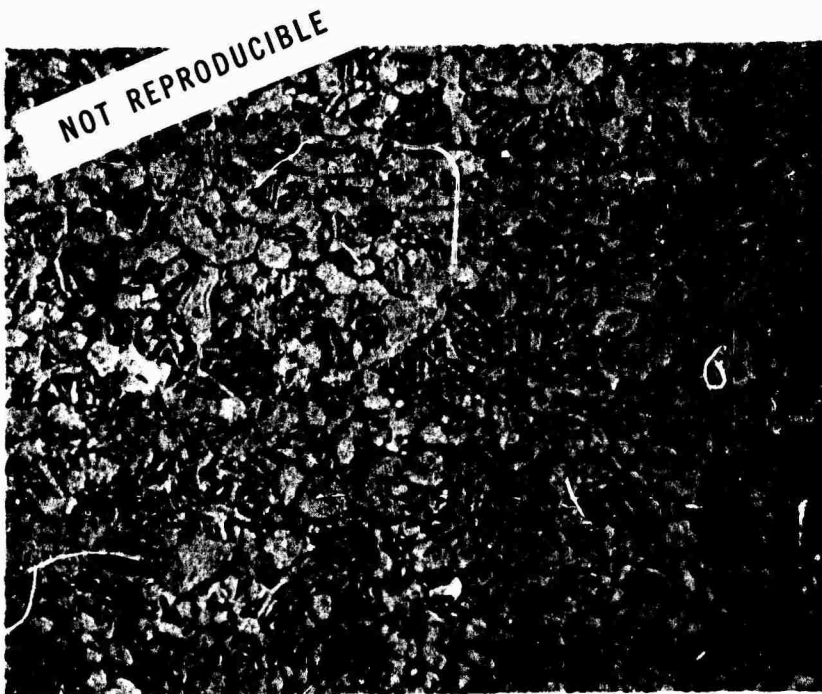

(b) Ti(6Al-4V), 500X

Fig. II-2 Microstructure of (a) 0.067-Inch-Thick and (b) 0.625-Inch-Thick Titanium (6Al-4V)

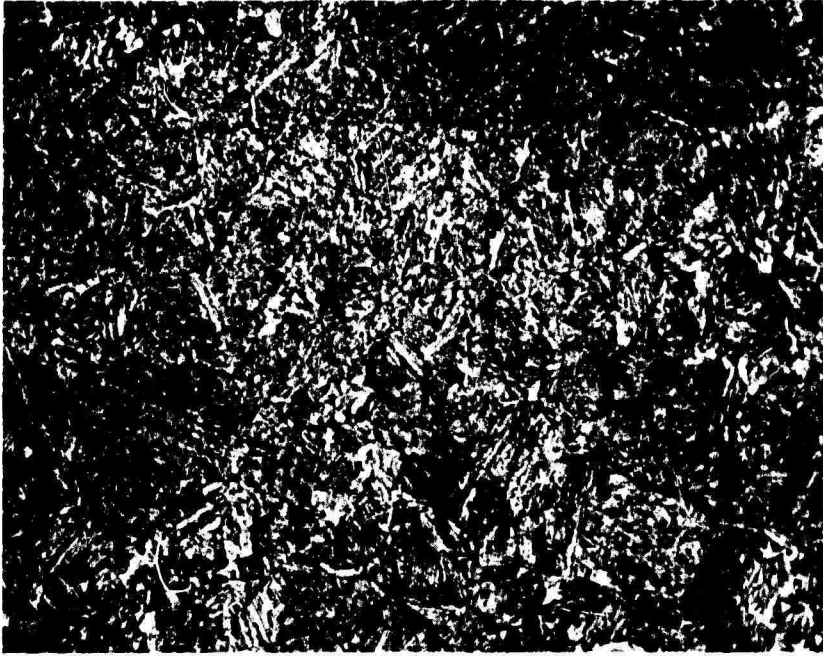

(a) Steel 4130, 500X

NOT REPRODUCIBLE

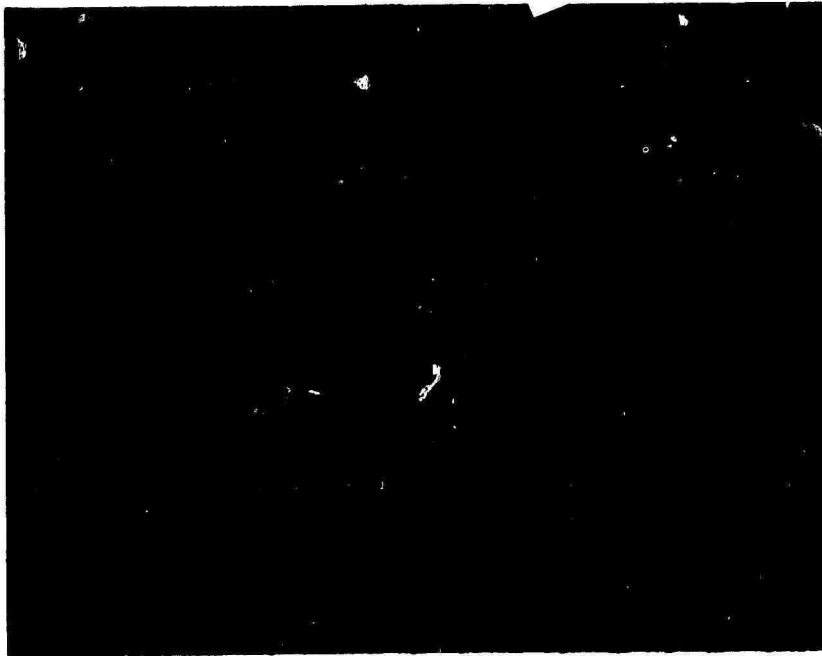

(b) Steel 4130, 500X

Fig. II-3 Microstructure of (a) 0.125-Inch-Thick and (b) 0.625-Inch-Thick Steel 4130

B. SPECIMEN CONFIGURATION

Historically, the first fracture mechanics-type specimens were the tensile specimens. Three of the specimens are symmetrical center-cracked plate, single-edge-notched plate, and surface-cracked plate. The center-cracked specimens contains an initial flaw at the center going entirely through the thickness. Eventually, it became apparent that the center-cracked specimen could be two single-edge-notched specimens. Then it was realized that in space applications most failures occurred under sustained load in pressure vessels not from through-the-wall cracks but from surface cracks. Therefore the surface-flawed specimen was developed. The thickness of the fracture mechanics specimen is important to the validity of the data if these are to be labeled as being plane strain data. The minimum thickness presently specified by the ASTM's Committee E-24 on Fracture Toughness depends on the yield strength σ_y . The current recommendation is that the thickness be not less than $2.5 \left(\frac{K_{IC}}{\sigma_y} \right)^2$.

This stipulation dictates that for plane strain testing aluminum 2014-T6 be 1-inch thick while titanium (6Al-4V) and 4130 steel each be 0.625-inch thick.

Specimens of large size pose formidable problems when tested in tension, but the same cross section poses a much more tractable problem when tested in bending. The bend-type specimens can be loaded in three point bending, four-point bending, or cantilever beam. Another specimen sometimes called the double-cantilever flared specimen is the Ripling (18) specimen, which offers the advantage that when a crack is propagating through the tapered section under constant load, the taper causes the K level to remain constant. This permits measurement of the crack propagation rate at constant K or at several levels of K determined only by the load.

Another group of specimens is commonly referred to as crack-arrest specimens. For stress corrosion work the stressing can be achieved by a bolt arrangement. For thin sheet materials, a hole is drilled through the sheet at a point along the slot and the hole is reamed with a standard taper pin. In the self-stressed specimens, the load is applied by a bolt or tapered pin to give a fixed displacement of the two arms of the specimen and the only other factor entering into stress intensity is the length of the crack. As the specimen is sufficiently loaded, a crack begins to grow. As the crack grows, the stress intensity at the crack tip decreases so the growth rate is decreased and the crack is arrested. Since we are primarily interested in measuring the rate of crack propagation under cyclic loading in the present contract, we have decided to use center-cracked specimens for plane stress testing (Fig. II-4) and a compact tension (CT) specimen for plane strain testing as shown in Figure II-5. We have also used the Ripling specimen for plane stress testing as shown in Figure II-6 and found it to be unsatisfactory.

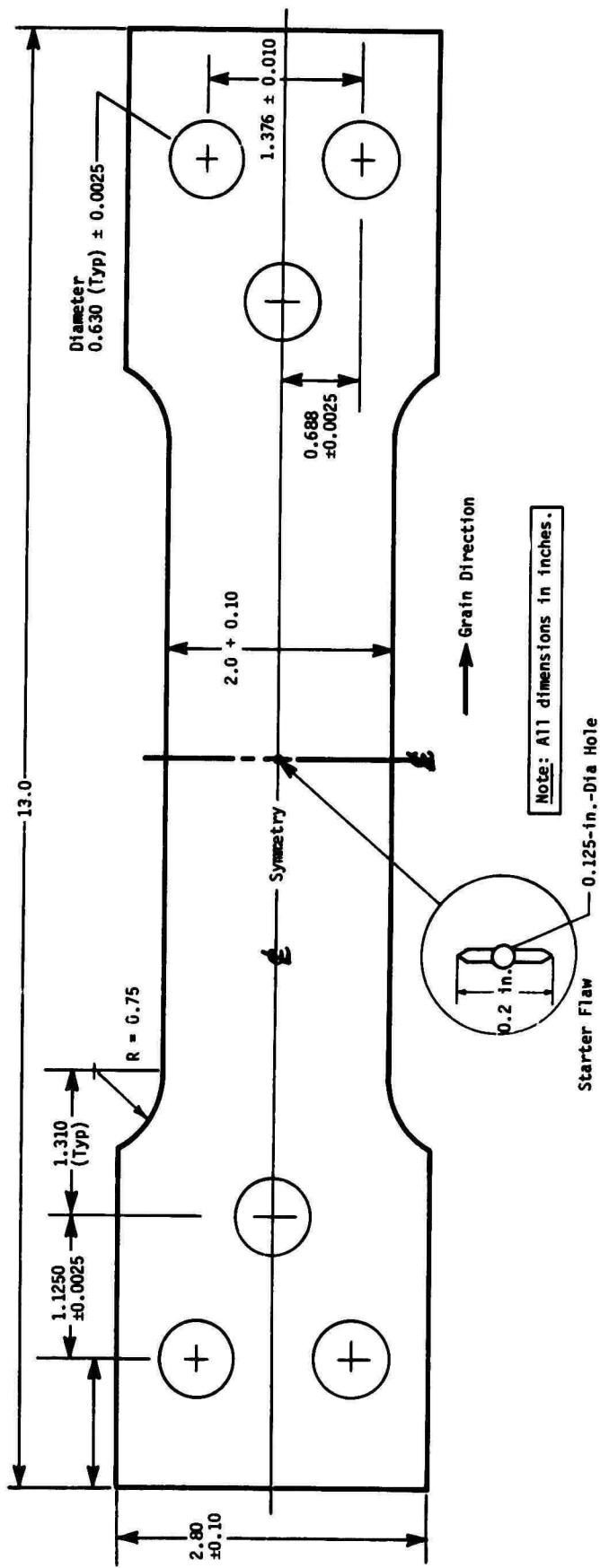

Fig. II-4 Center-Cracked Specimen

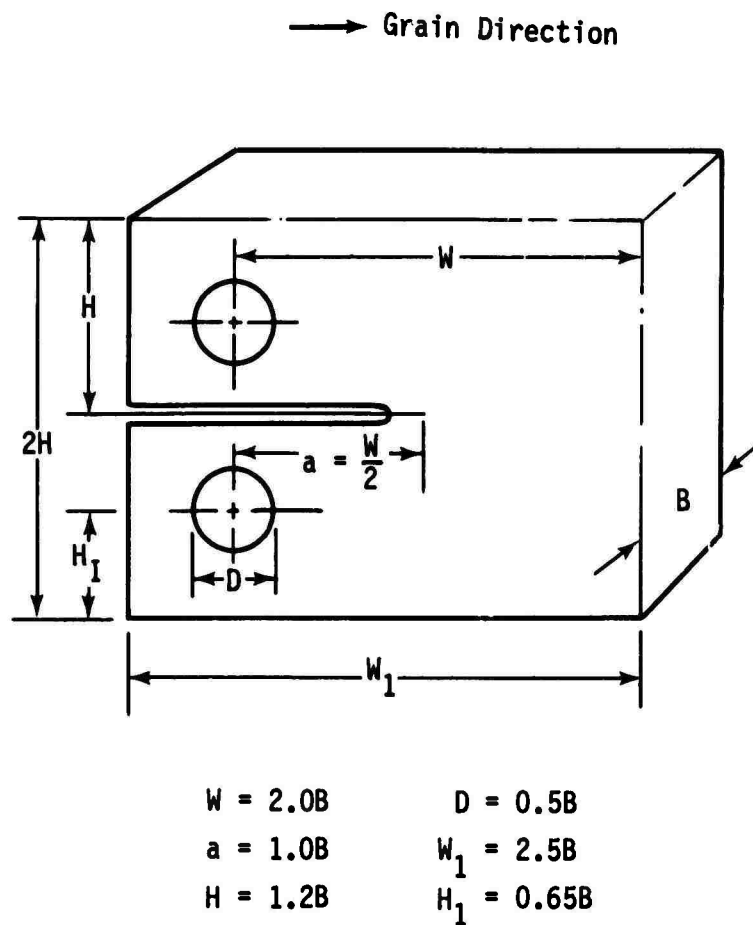

Fig. II-5 Proportions of Modified Compact Tension Specimen

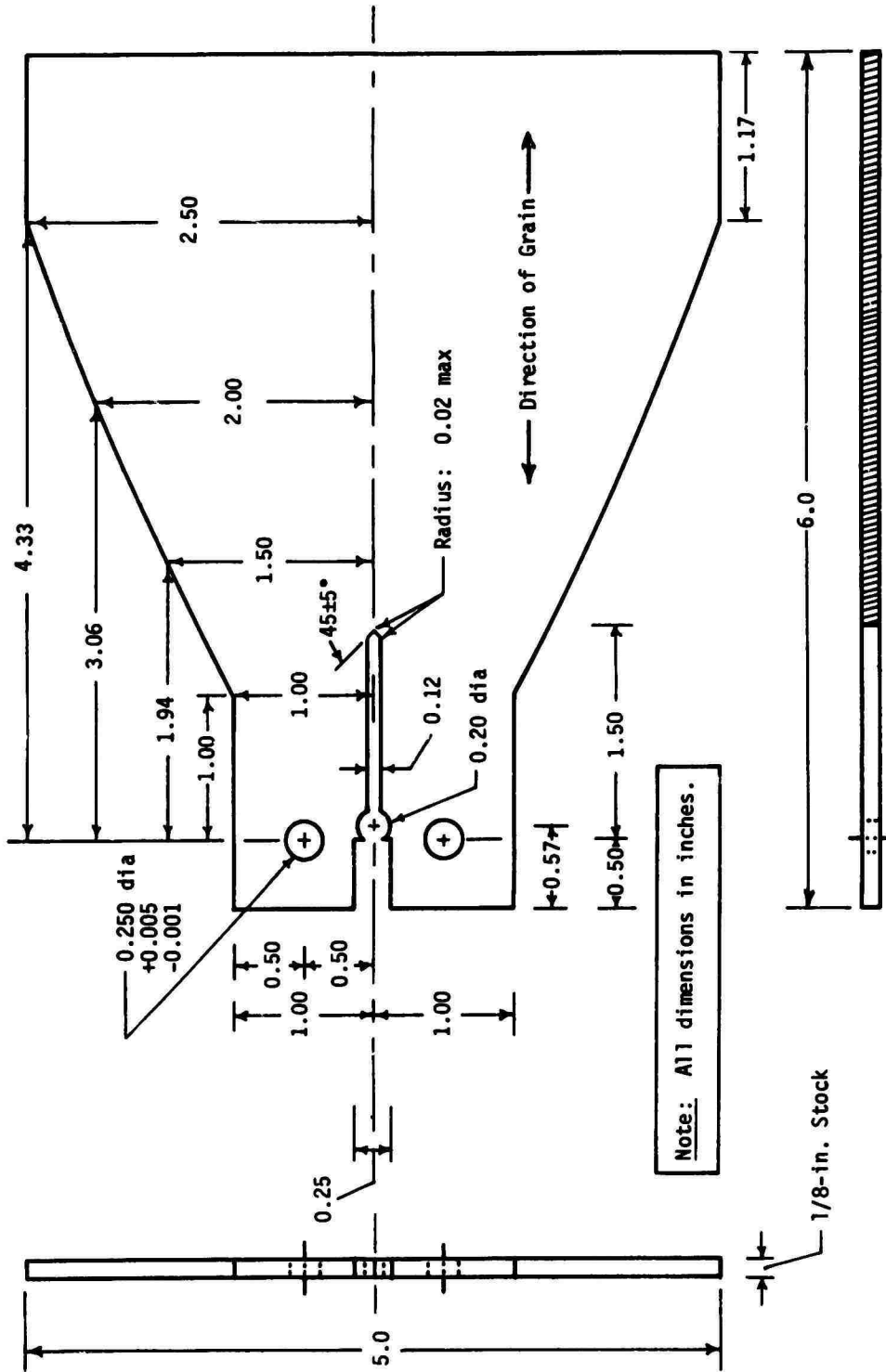

Fig. II-6 Ripling Type M-4 Test Specimen

C. TESTING

All cyclic loading tests were conducted in MTS electrohydraulic machines. A sinusoidal pulse was used and the load was monitored by a load cell. The prestressing was done in machines of various capacities such as Instron (10,000 lb), Baldwin (50,000 lb), and a 500,000-pound Martin Marietta testing system. After the stress relieving treatment, a 0.125-inch-diameter hole was drilled in the center-cracked specimens. A jewelers' saw was used to form the wings of the initial flaw. In the case of plane strain testing, the prestressing treatment was given to 1-inch-thick aluminum bars, 0.625-inch-thick titanium (6Al-4V), and 0.625-inch-thick 4130 steel before specimen machining. The CT specimens were machined out after the prestressing.

All the crack length measurements were carried out optically with a traveling microscope and a strobe light. The accuracy of the crack length measurements was ± 0.0001 inch. A series of experiments was conducted to determine the reproducibility of the number of cycles required to initiate the starter crack. Two 0.067-inch thick specimens of titanium (6Al-4V) were tested under identical condition. For the starter flaw to grow from 0.20 to 0.25 inch, the number of cycles required for one specimen was 45,000 as compared to 48,000 for the other specimen. For the case of aluminum 2014-T6 1-inch-thick CT specimens, the starter flaw was initiated in 80,000 cycles in one specimen as compared to 75,000 cycles in the other. From these data it appears that the number of cycles required to propagate the initial flaw is reproducible within $\pm 3\%$; however, in order to be conservative only changes greater than about 10% were considered to be meaningful.

III. EXPERIMENTAL RESULTS

This chapter summarizes the test data in graphical form. The crack propagation behavior of three materials -- titanium (6Al-4V), 4130 steel, and aluminum 2014-T6 -- under plane stress and plane strain conditions is presented. The effect of prestressing and surface removal treatment on the rate of crack propagation is shown. The stress intensity change ΔK for the specimens shown in Figures II-4 and II-5 was calculated as

$$\Delta K = \left(\frac{\Delta L \cdot \sqrt{a}}{B \cdot W} \right) (F) \quad [5]$$

where

ΔL is the difference in the maximum and minimum load,

W is the width of the specimen,

B is the thickness,

a is the crack length,

$$F = \sqrt{W \tan \frac{\pi a}{W}} \text{ for center-cracked specimens,}$$

and $F = 23.12 - 67.67 \left(\frac{a}{W} \right) + 97.31 \left(\frac{a}{W} \right)^2$ for CT specimens as shown by Wessel (19).

The ratio $R = K_{\min} / K_{\max}$ was held constant and equal to 0.25.

As an average, three specimens were used to get the representative data. All testing was conducted at a frequency of 20 Hz unless otherwise specified. Prestressing was done at room temperature at strain rates on the order of 10^{-3} seconds⁻¹.

A. PLANE STRESS TESTING

1. Titanium (6Al-4V)

The crack length $2a$ as a function of number of cycles N is plotted in Figure III-1 for titanium (6Al-4V) center-notched specimens that were 0.067-inch thick. The specimens were cycled at 20 Hz between the stress limits of 4.5 to 18.0 ksi. Since the initial crack length $2a$ was equal to 0.2 inch, the K_{initial} is equal to $7.6 \text{ ksi}\sqrt{\text{in}}$. Another batch of specimens was prestressed to 110 ksi and chem-milled to remove about 0.003 inch from each face. The starter flaw was put in after the prestressing and surface removal treatment.

The untreated specimens were also chem-milled before putting in the starter flaw so the effect of prestressing could be compared. The data from both S-SLE-treated and untreated specimens are shown in Figure III-1. It can be observed that for the untreated specimens the initial flaw started to propagate after 160,000 cycles but for the SSR-treated specimens the initial flaw did not propagate even up to 6.3 million cycles. For the untreated specimens, the crack length increased with cycling and the rate of crack propagation da/dN increased with increasing crack length since ΔK was increasing. However, the applied stress $\Delta\sigma$ remained unchanged. We have drawn smooth curves through the data points and calculated the value of da/dN and ΔK at regular intervals.

Typical curves showing the effect of the prestressing and surface layer elimination (S-SLE) treatment on crack initiation and crack propagation are given in Figures III-2 and III-3. It may be seen that the S-SLE treatment not only increased the number of cycles required to initiate the crack propagation but also the rate of crack propagation was decreased. A comparison of the appropriate data in Figures III-2 and III-3 also indicates that the crack initiation and growth were appreciably improved as the stress decreased. The effect of prestressing above the yield strength may be seen in Figure III-2. When specimens were prestressed to a strain, ϵ , of 0.015 (corresponding to 133 ksi) and the surface layer was eliminated either by relaxation (SLE-R) or by chem-milling (SLE-C), the crack initiation and crack propagation behavior was about the same as that of the untreated specimens. However, as will be seen in Figure III-4, it appears that eliminating the surface layer by relaxation gives a somewhat lower propagation rate than obtained by the chem-milling method.

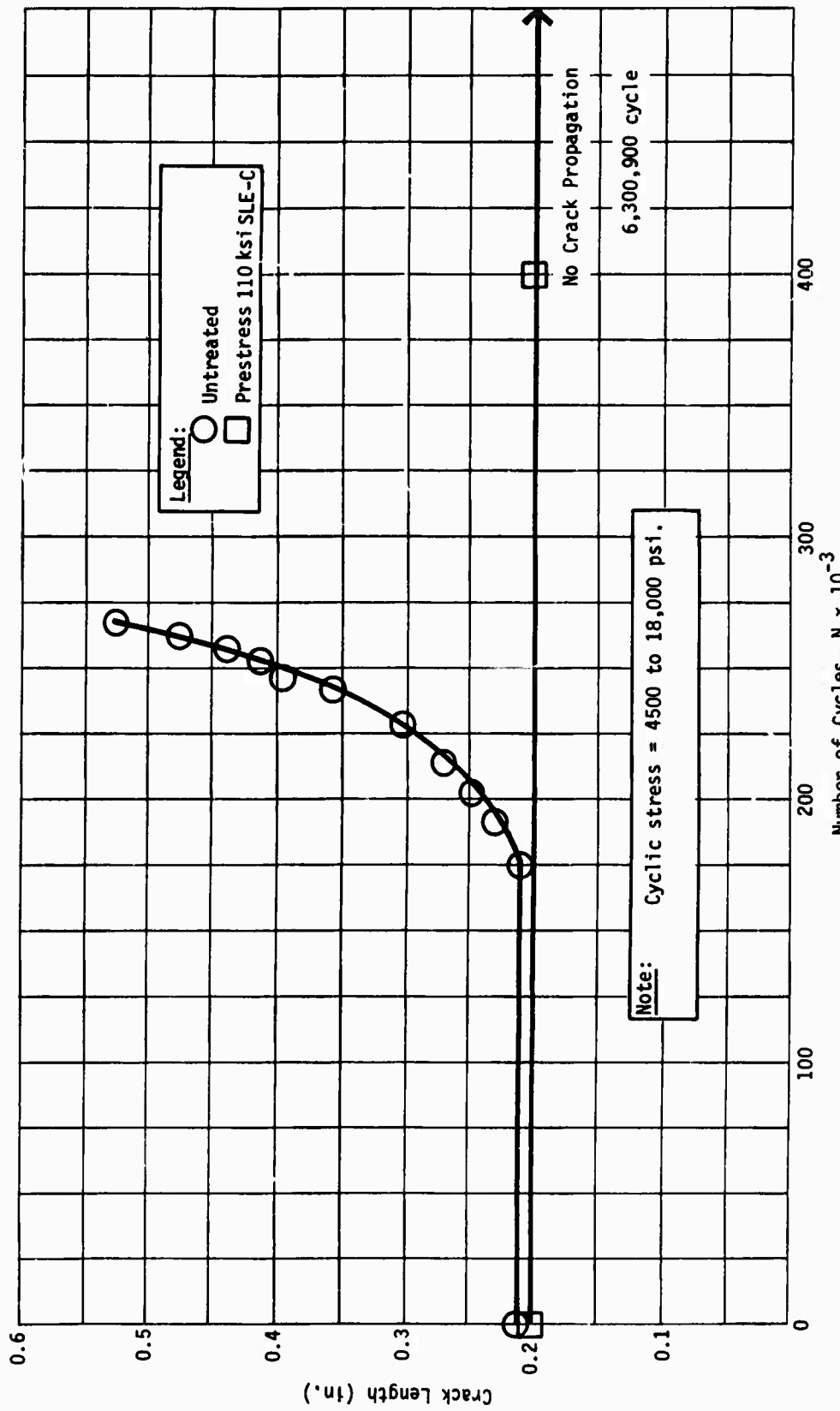

Fig. III-1 Effect of Prestress and Surface Removal on the Crack Propagation Rate of Titanium (6Al-4V) under Plane Stress Conditions, Center-Cracked Specimens 0.067-Inch Thick

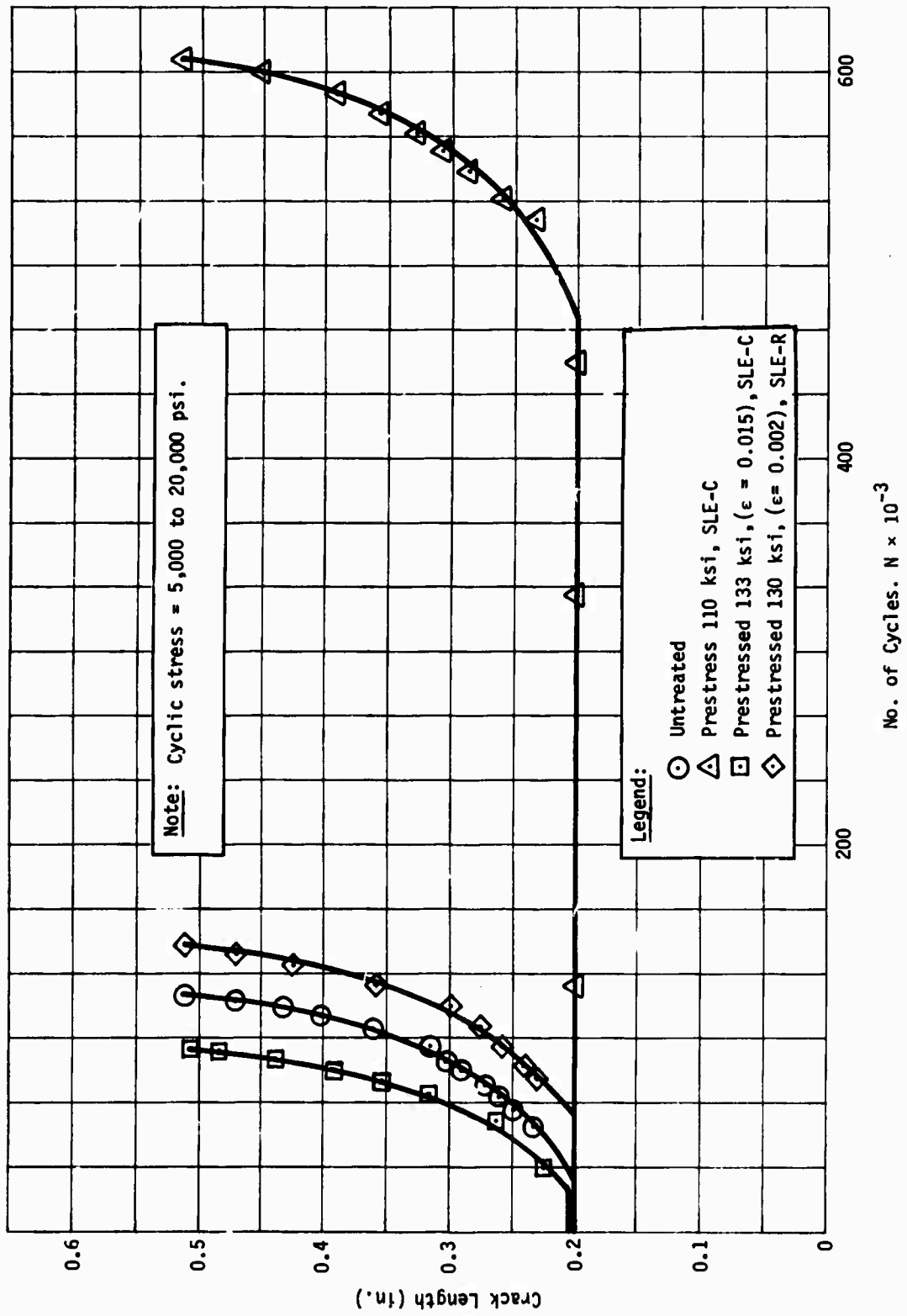

Fig. III-2 Crack Propagation Behavior of Titanium (6Al-4V) under Plane Stress Conditions, Center-Cracked Specimens 0.067-inch Thick.

A composite curve showing the rate of crack growth, da/dN , as a function of ΔK is shown in Figure III-4. These data show that the improvement obtained by the S-SLE treatment increases as the ΔK values are decreased. For example, at a ΔK of $7.6 \text{ ksi}\sqrt{\text{in.}}$ for the untreated specimen, da/dN was $5.5 \times 10^{-7} \text{ in./cycle}$ and complete failure occurred in about 250,000 cycles. For the treated specimens no crack growth was observed below 6.3 million cycles. The tests were terminated at that time (Fig. III-1).

The subcritical crack growth behavior of center-cracked specimens of titanium (6Al/4V) is given in Figures III-5, III-6, and III-7. In these tests the notch was extended from its original length of 0.2 inch to 0.5 inch by fatigue cycling and then the specimens were loaded in a creep rack. The curves presented in Figure III-5 are typical of the improvement of the crack growth rates obtained by the S-SLE treatment. It is quite apparent that the growth rates, da/dt , for the same K values are decreased. From these curves (Fig. III-6) it also appears that the K_c value may also have been increased by the S-SLE treatment from 8.5 to $8.7 \text{ ksi}\sqrt{\text{in.}}$, an improvement of 25%. The crack growth rate as a function of K/K_c is given in Figure III-7. This plot shows that for the same K/K_c value the S-SLE treated specimens have a much lower crack growth rate, da/dt , than the untreated specimens.

One can observe that prestressing and surface removal treatment reduces the subcritical crack growth rate. We have concluded that the subcritical crack growth behavior of metals is very sensitive to the applied stress intensity and therefore a very large number of data points are needed to establish the statistical reliability of the subcritical crack growth data in air.

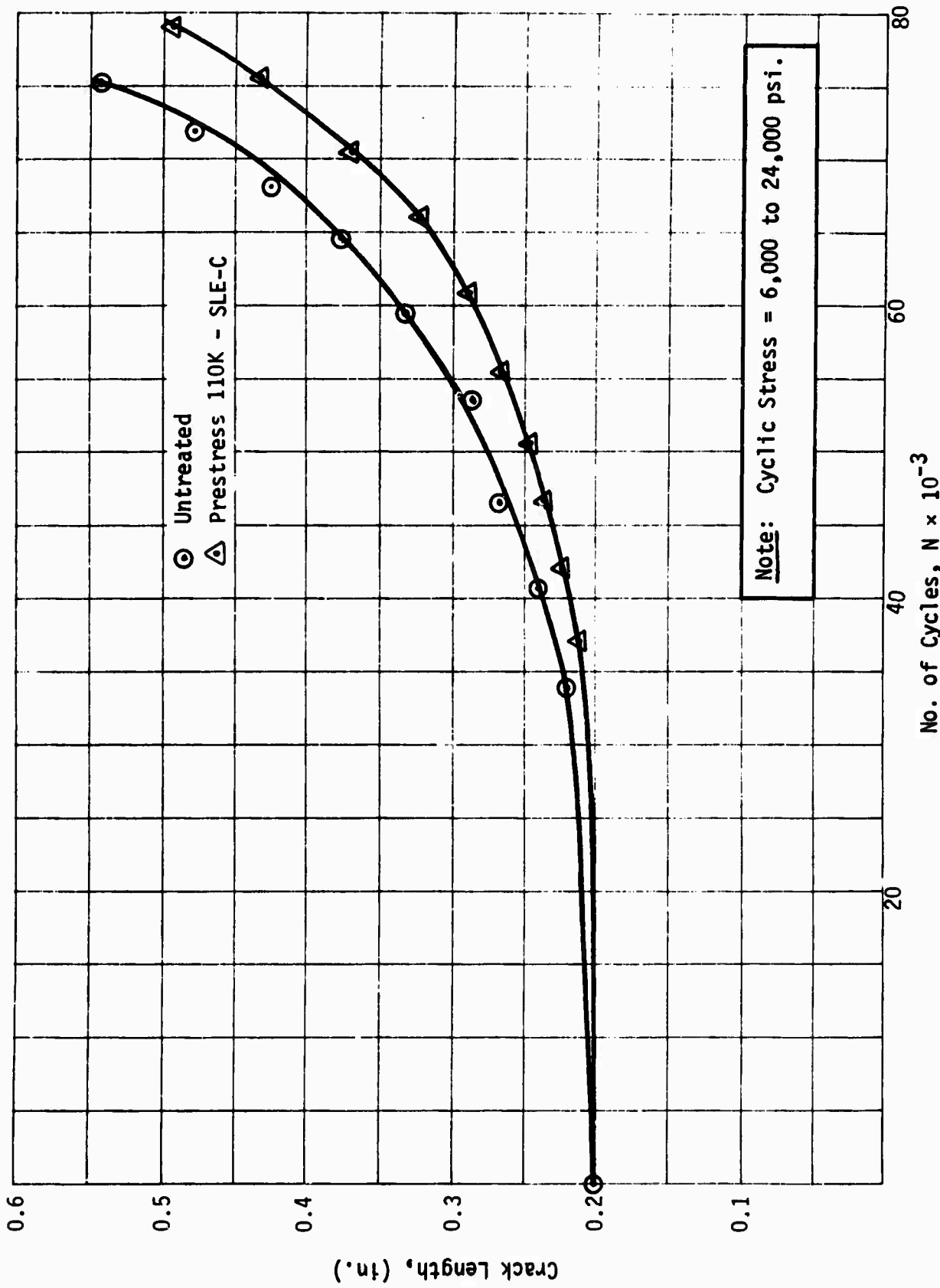

Fig. III-3 The Effect of Prestress and Surface Removal on the Crack Propagation Rate of Titanium (6Al-4V) Under Plane Stress Conditions, Center-Cracked Specimens 0.067-inch Thick

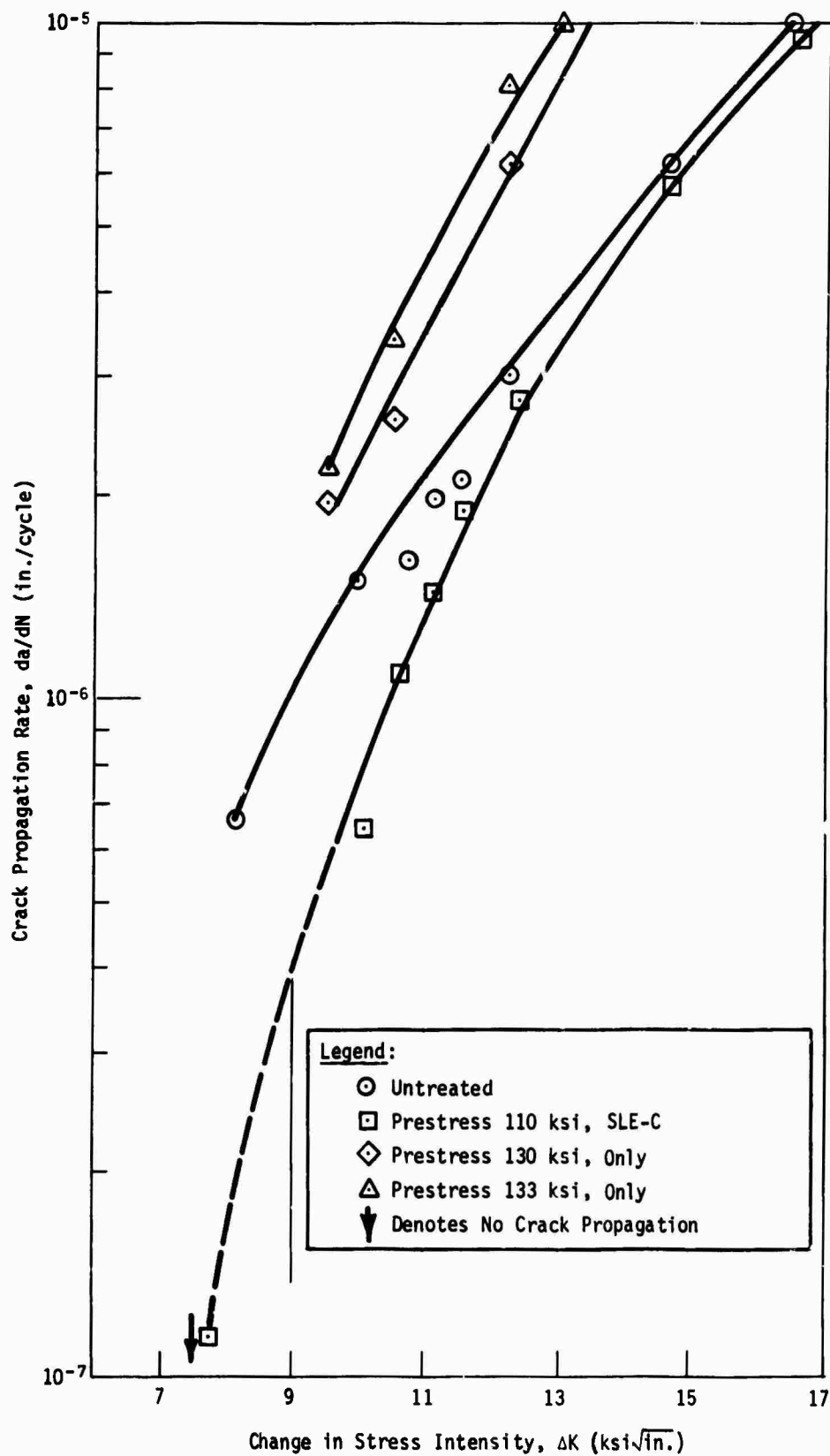
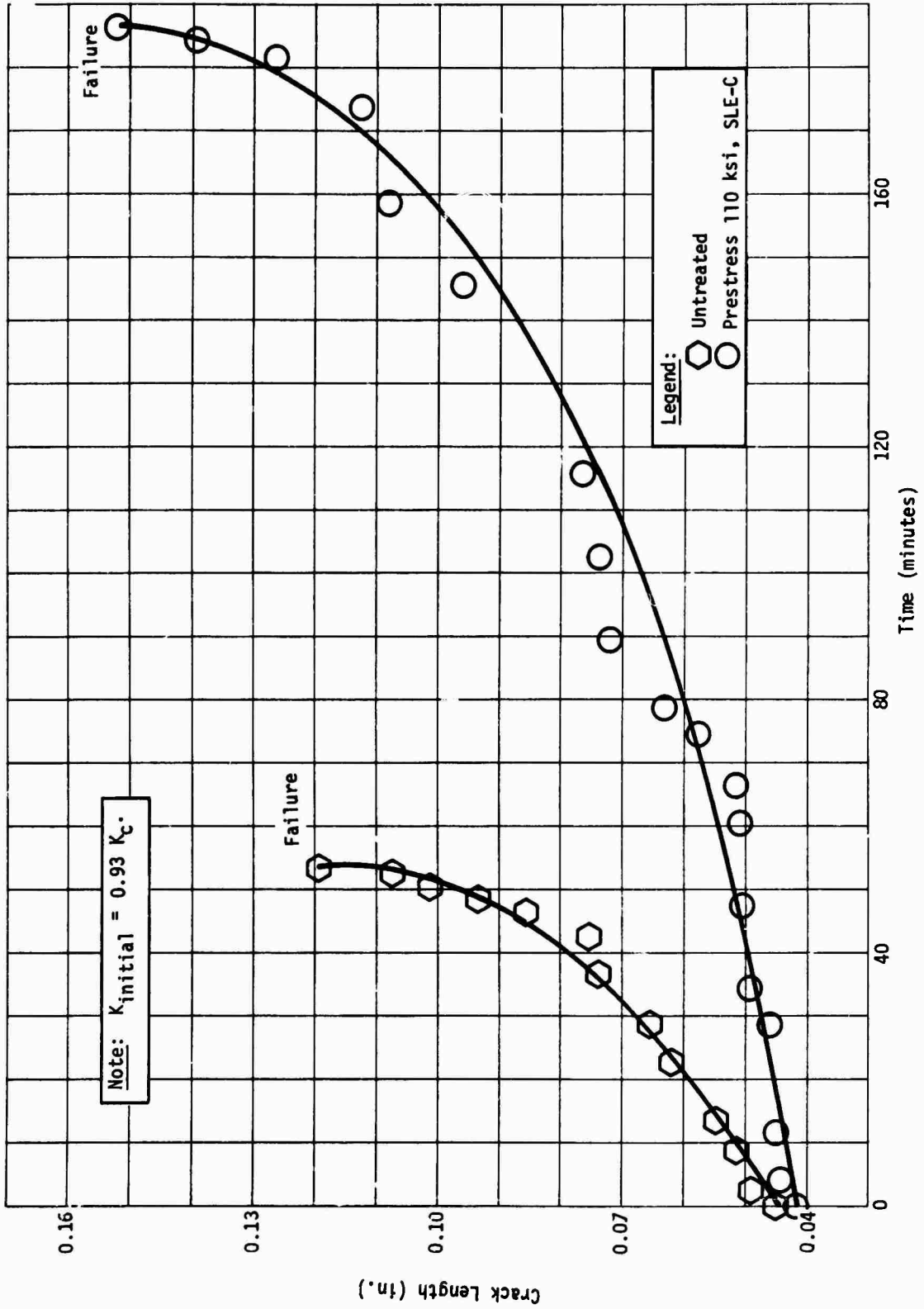

Fig. III-4 Crack Propagation Behavior of Titanium (6Al-4V) under Plane Stress Conditions, Center-Cracked Specimens 0.067-Inch Thick.



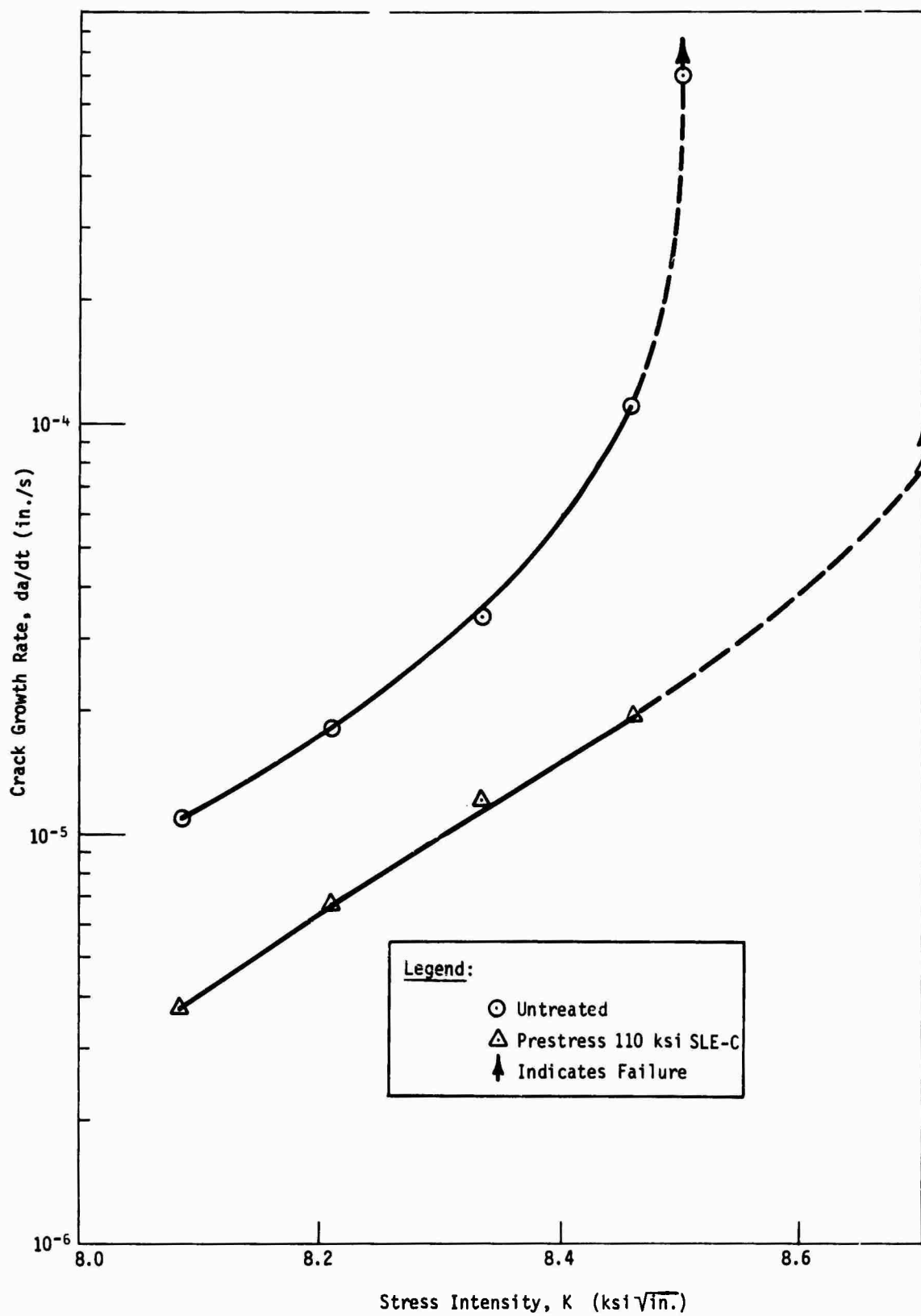

Fig. III-6 Crack Growth Behavior of Titanium (6Al-4V) under Plane Stress Conditions, Center-Notched Specimen 0.067-Inch Thick

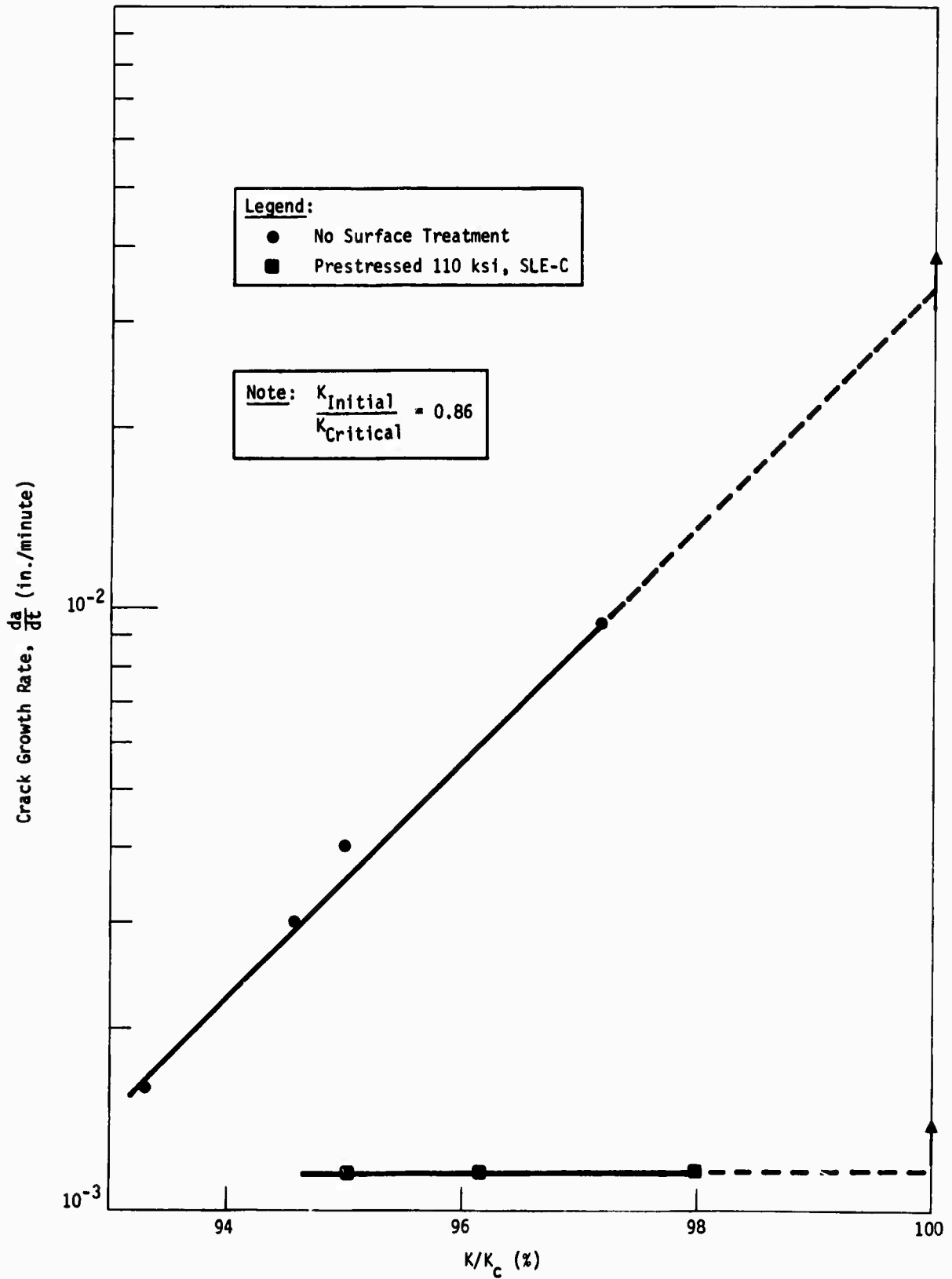

Fig. III-7 The Effect of Prestress and Surface Removal on the Crack Growth Rate of Titanium (6Al-4V) under Plane Stress Conditions, Center-Notched Specimens 0.067-Inch Thick.

2. 4130 Steel

The crack propagation behavior of 4130 Steel is shown in Figures III-8 through III-13 for various stress amplitudes. The ratio of the stress limits was maintained at 0.25. The data in terms of da/dN and the change in stress intensity factor, ΔK are summarized in Figure III-13. Similar to the results reported in Subsection 1 for the titanium alloy, the prestress and surface layer removal treatment improved the crack initiation and crack propagation resistance. The S-SLE treatment was most effective at the lower ΔK values (below about $10 \text{ ksi } \sqrt{\text{in.}}$). The effect of the amount of prestress on the subsequent behavior of the S-SLE-treated specimens may be seen in Figure III-9. For these tests the specimens were prestressed to 180 ksi, which corresponds to a plastic strain of 1.5%. As in the case of the titanium alloy, an excessive amount of prestressing is detrimental to the crack propagation resistance even after the surface layer was removed. As shown in Figure III-9, the crack growth resistance of 4130 steel specimens that were prestressed to 180 ksi before the surface layer was removed was somewhat inferior to the untreated case. For the 180 ksi-treated specimens the initial flaw began to propagate at about 150,000 cycles compared to 250,000 cycles for the untreated specimens. The S-SLE treatment appears to be very effective in increasing the resistance to the initiation of cracks. Whereas rather rapid crack growth occurred in the untreated specimens in the cyclic stress range of 5000 to 20,000 psi, no crack growth occurred in the treated specimens until the specimens were cycled in the range from 5500 to 22,000 psi. The "endurance limit" appears to be in the region between 5250/21,000 and 5500/22,000 psi.

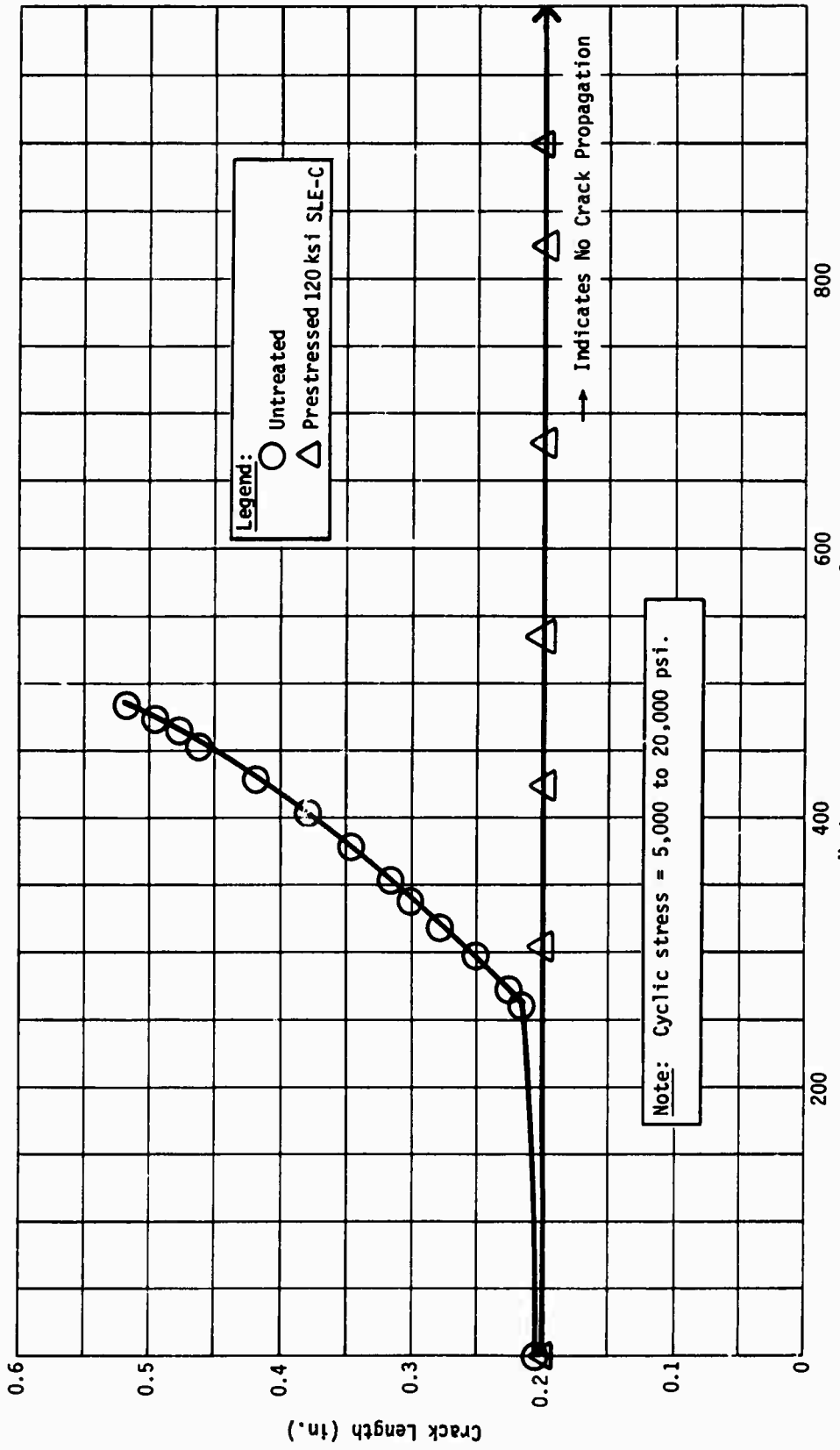

Figure III-8 Crack Propagation Behavior of 4130 Steel under Plane Stress Conditions, Center-Cracked Specimens 0.067-Inch Thick

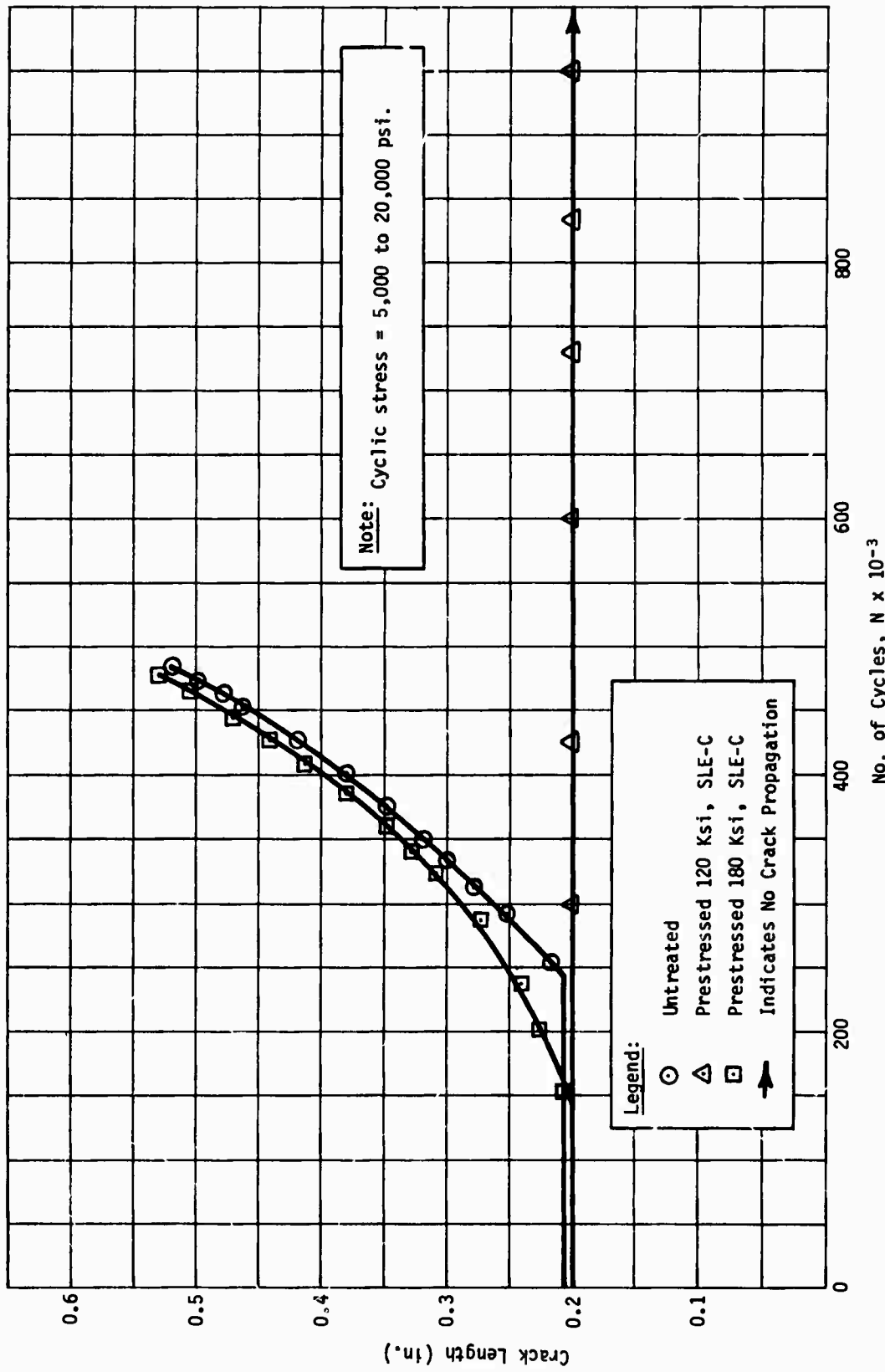

Figure III-9 Crack Propagation Behavior of 4130 Steel under Plane Stress Conditions, Center-Cracked Specimens 0.125-Inch Thick

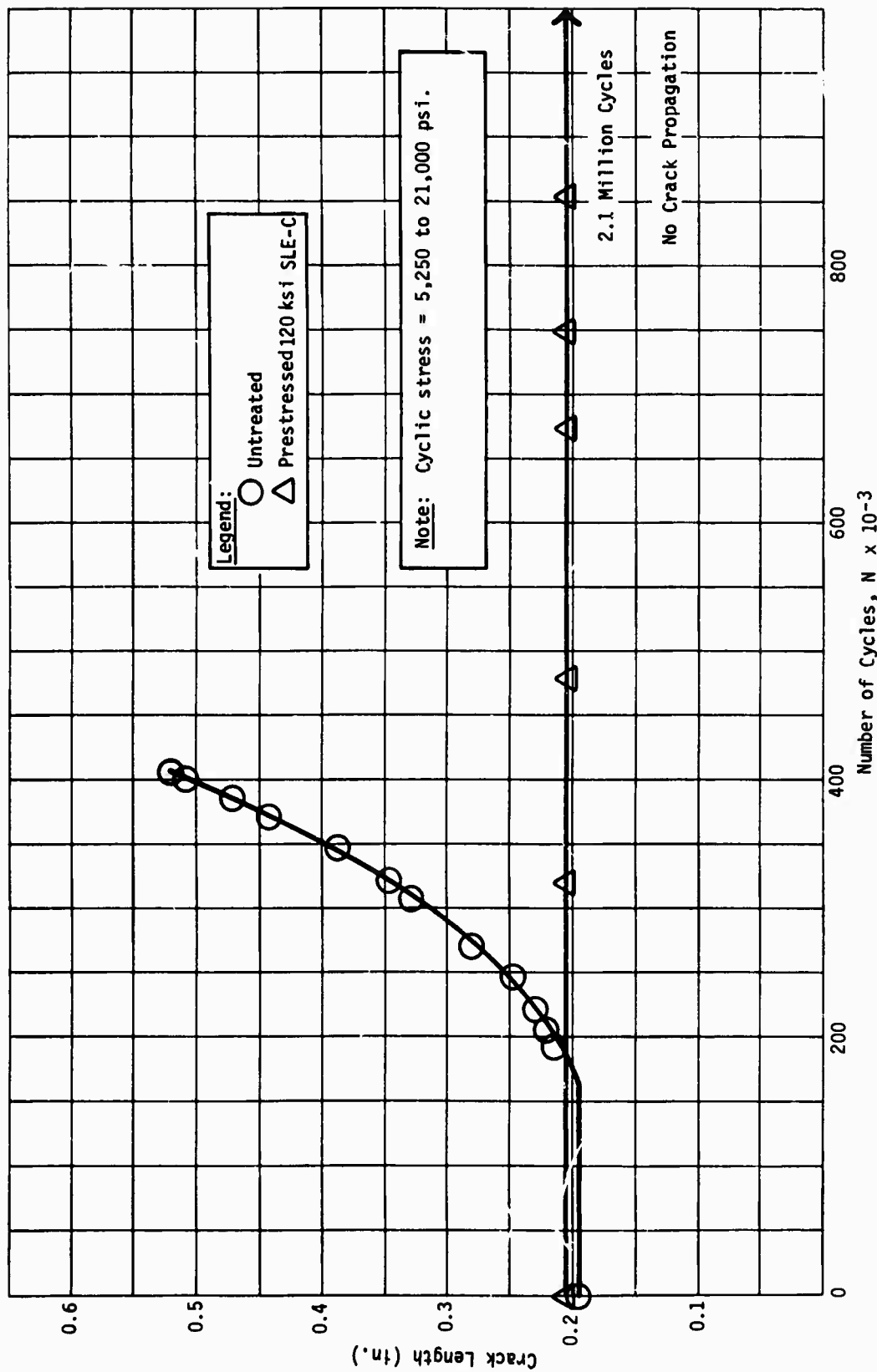

Figure III-10 Crack Propagation Behavior of 4130 Steel under Plane Stress Conditions, Center-Cracked Specimens 0.125-Inch Thick

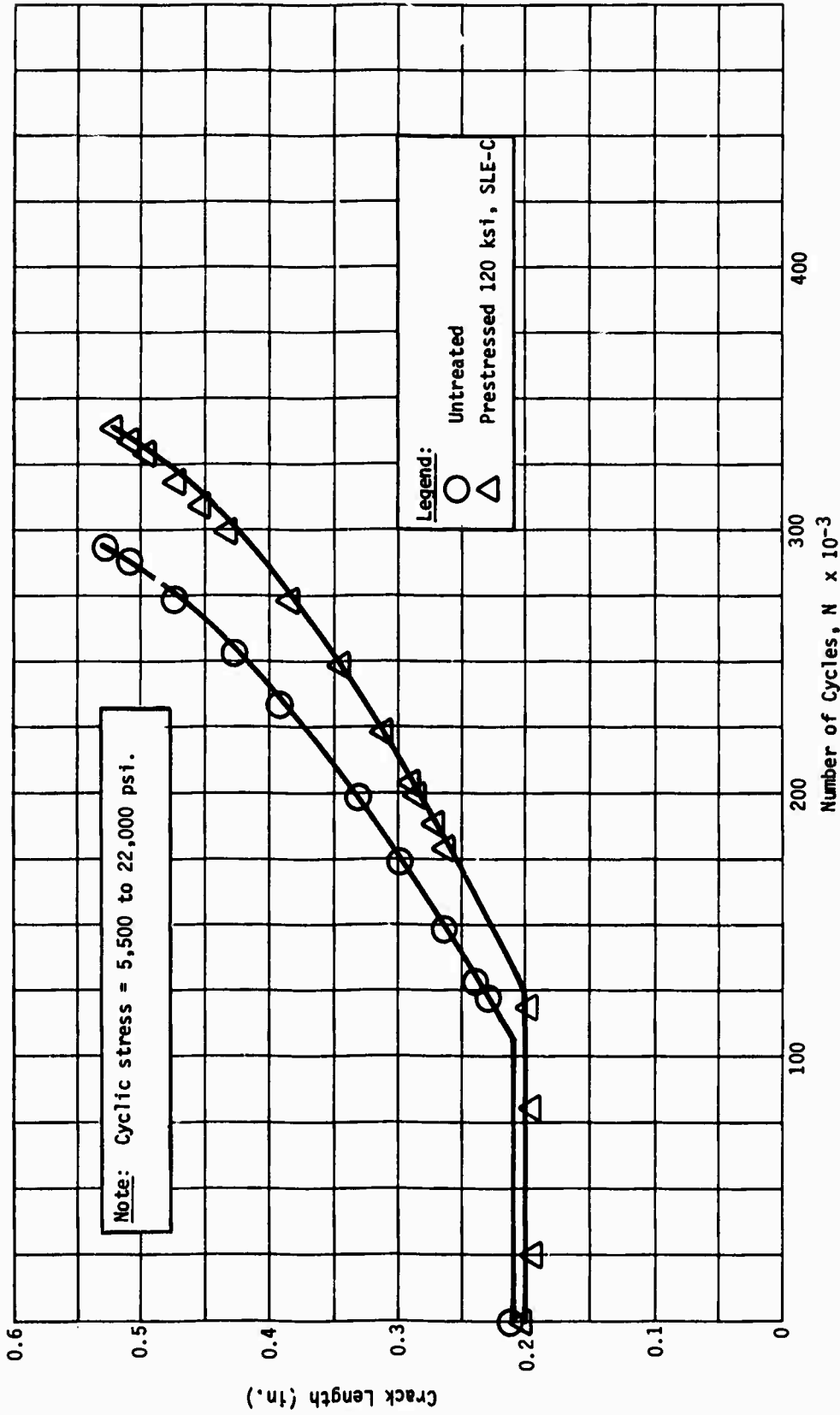

Figure III-11 Crack Propagation Behavior of 4130 Steel under Plane Stress Conditions, Center-Cracked Specimens 0.125-Inch-Thick

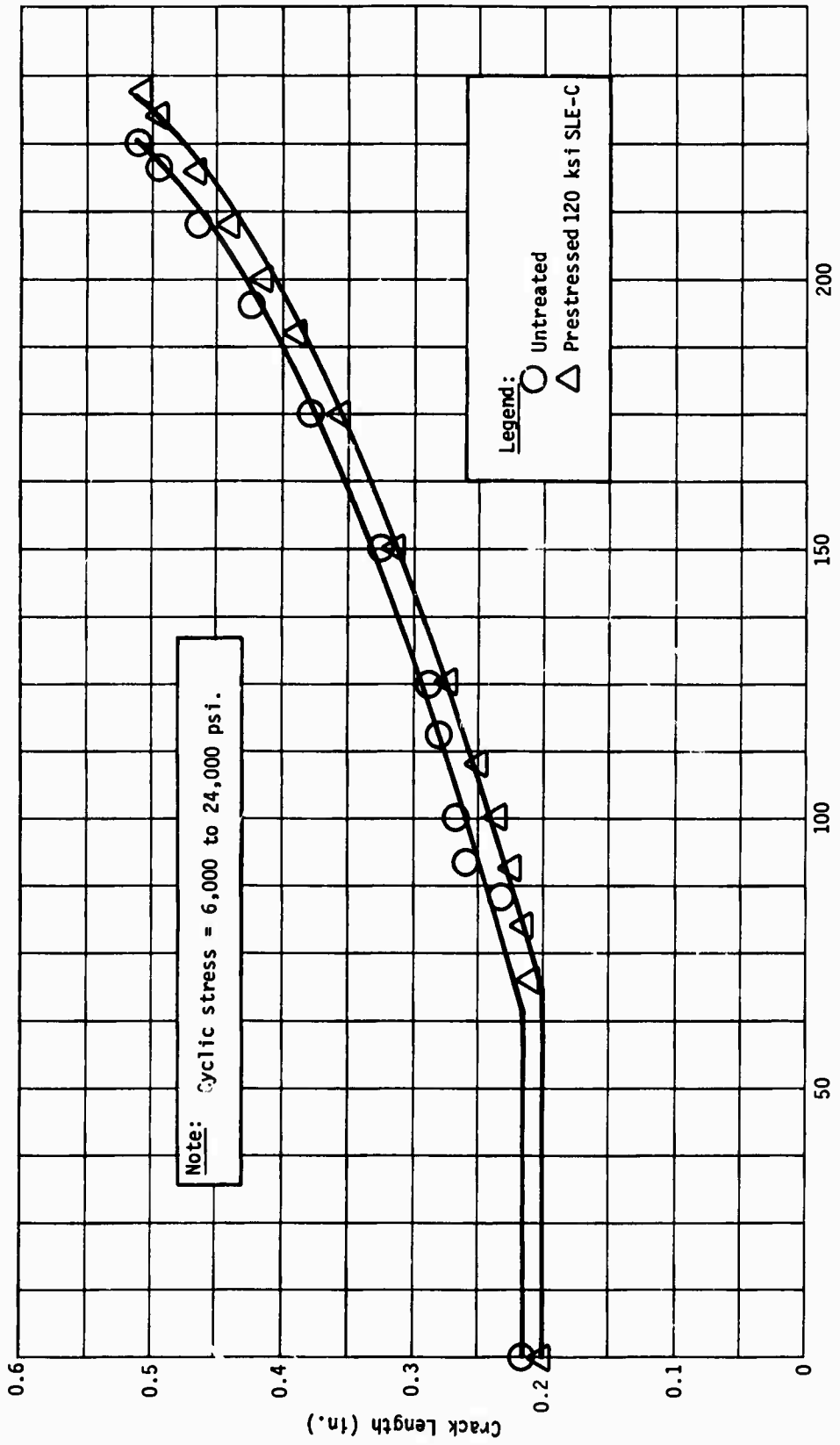

Figure III-12 Crack Propagation Behavior of 4130 Steel under Plane-Stress Conditions, Center-Cracked Specimens 0.125-Inch Thick

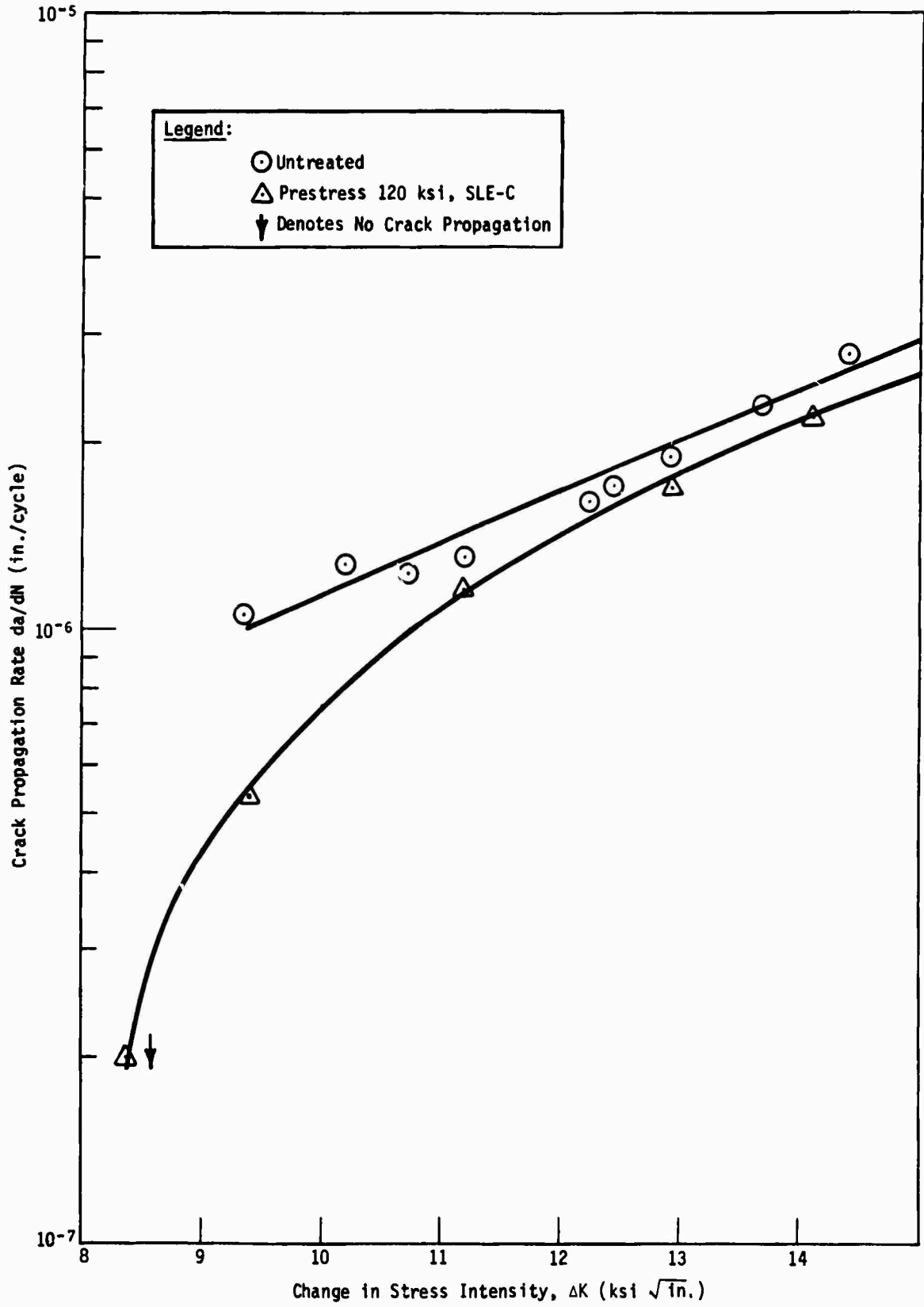

Figure III-13 Crack Propagation Behavior of 4130 Steel under Plane Stress Conditions, Center-Cracked Specimens 0.125-Inch-Thick

3. Aluminum 2014-T6

The crack propagation rates in center-cracked 1/8-inch-thick aluminum 2014-T6 specimens are given in Figures III-14 thru III-16. Similar to the results obtained for the titanium alloy and 4130 steel, an improvement in the crack resistance was found at the lower ΔK values for specimens that had been prestressed and the surface layer removed. The data appear to indicate that crack propagation was improved more by prestressing at 40 ksi than at 45 ksi; however, more data are required since the crack propagation rates were measured at two different stress limits. From the data in Figure III-15 it appears that prestressing at 45 ksi without removing the surface layer increases the crack propagation rate more than that of specimens from which the surface layer had been removed after the prestress operation. We have measured the value of da/dN and ΔK at regular intervals and these data are plotted in Figure III-16.

4. Rippling Specimen

We have used the Rippling (18) M-4 specimen for crack propagation measurements under constant ΔK levels. The main advantage of the Rippling specimen is that the taper keeps the stress intensity K constant independent of crack length. The stress intensity is determined only by the load. We have used the Rippling M-4 for plane stress testing of 1/8-inch-thick aluminum 2014-T6 and titanium (6Al-4V). A special loading jig was designed and manufactured to prevent buckling of the specimens. Teflon sheets were used to minimize friction between the backing plates and specimen. The specimens were loaded in the jig and the rate of crack propagation was measured. It was observed that the crack had a strong tendency to veer off rather than propagate in a straight line.

While it was not possible to keep the crack in a straight line for titanium (6Al-4V), Figure III-17, crack propagation could be measured in aluminum 2014-T6 up to a 1-inch crack length. The effect of frequency of loading on the crack growth rate is shown in Figure III-18. One can observe that da/dN decreases from 1.7×10^{-5} to 1.2×10^{-5} in./cycle when the frequency of the applied load is increased from 1 to 20 Hz.

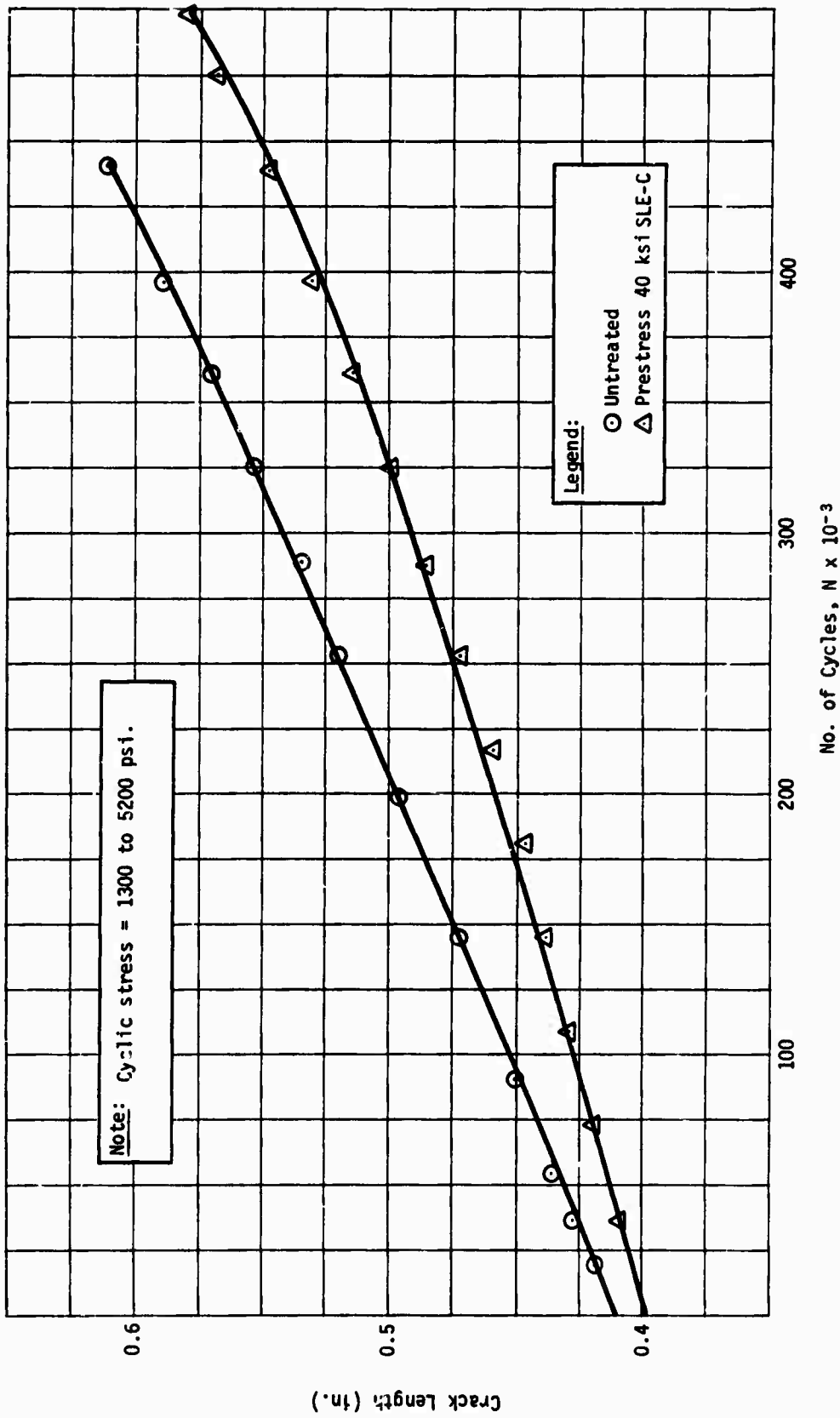

Figure III-14 Crack Propagation Behavior of 2014-T6 Aluminum under Plane Stress Conditions, Center-Cracked Specimens 0.125-Inch Thick

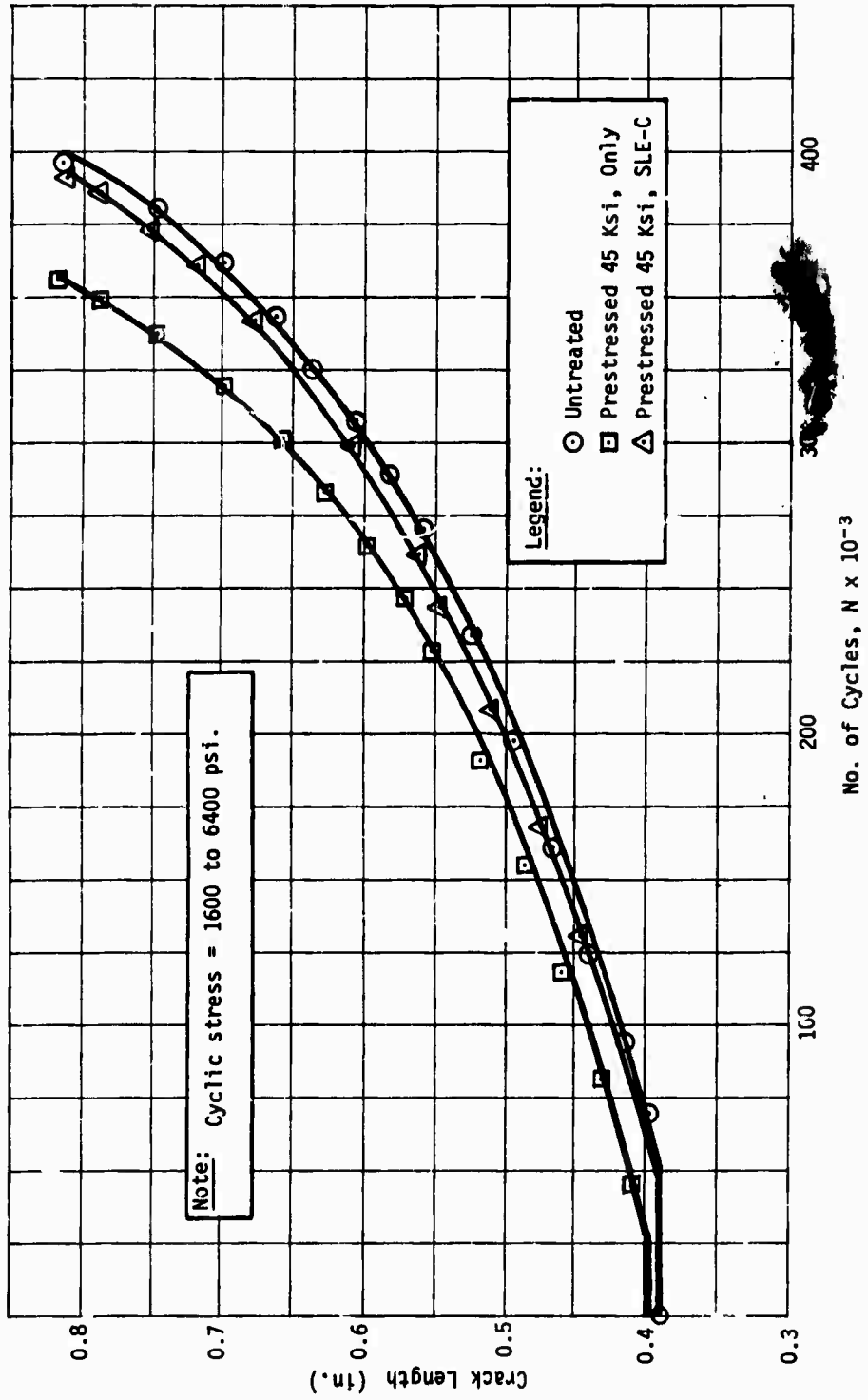

Figure III-15 Crack Propagation Behavior of Aluminum 2014-T6 under Plane Stress Conditions, Center-Cracked Specimens 0.125-Inch Thick

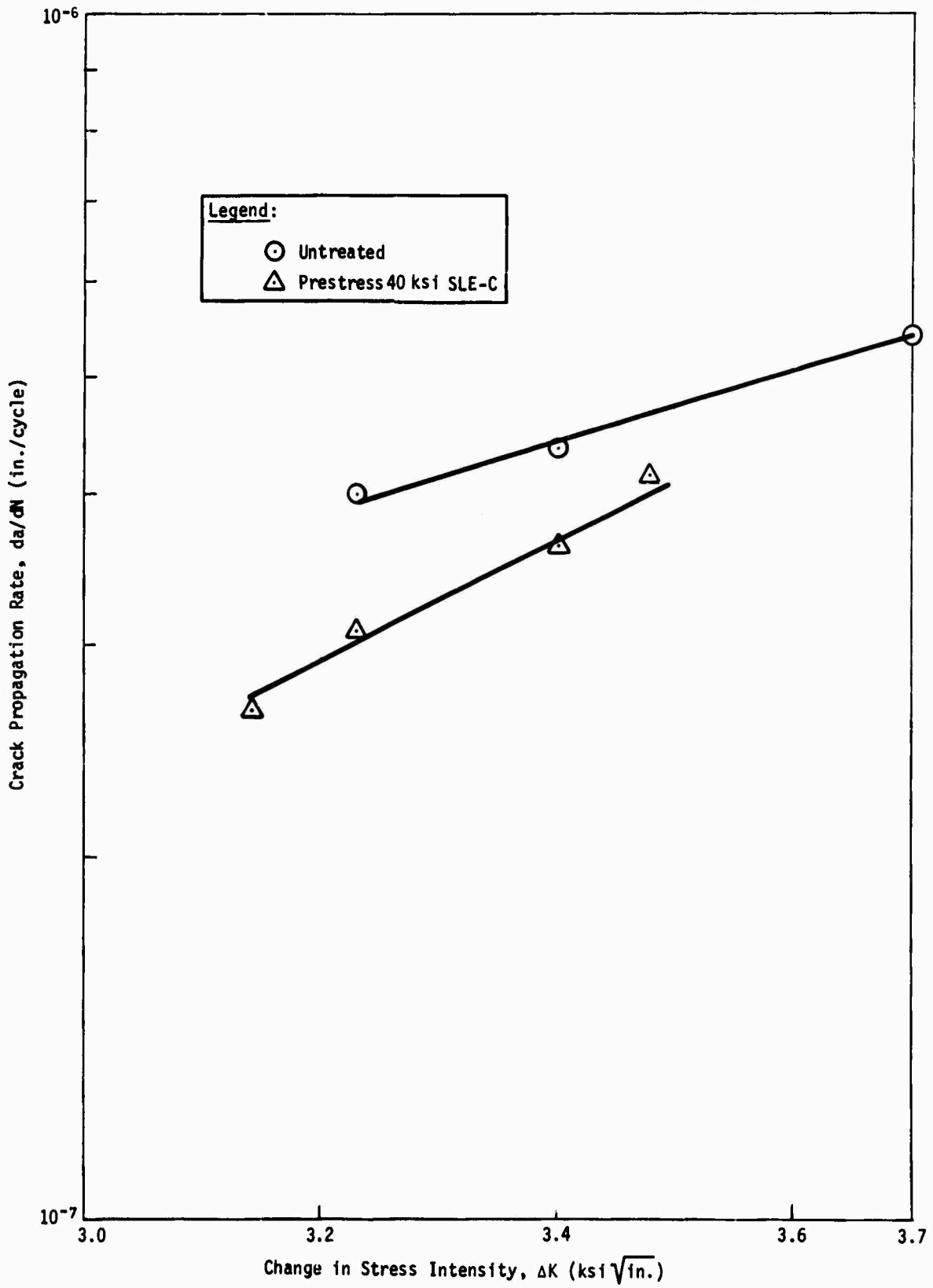
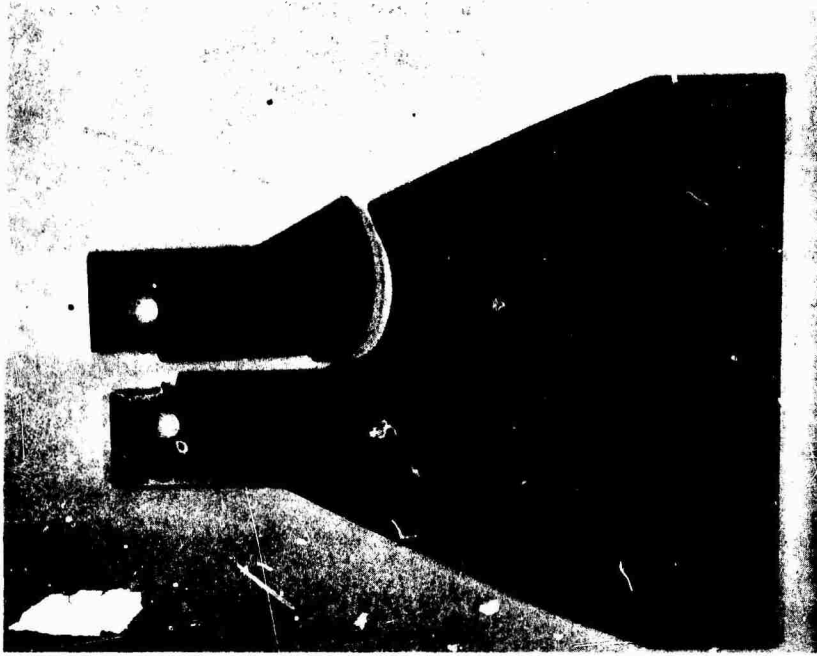

Fig. III-16 Crack Propagation Behavior of Aluminum 2014-T6 Under Plane Stress Conditions, Center-Cracked Specimens 0.125-Inch Thick



NOT REPRODUCIBLE

Fig. III-17 Ripling (6Al-4V) Specimen Showing Veering Off the Crack Front

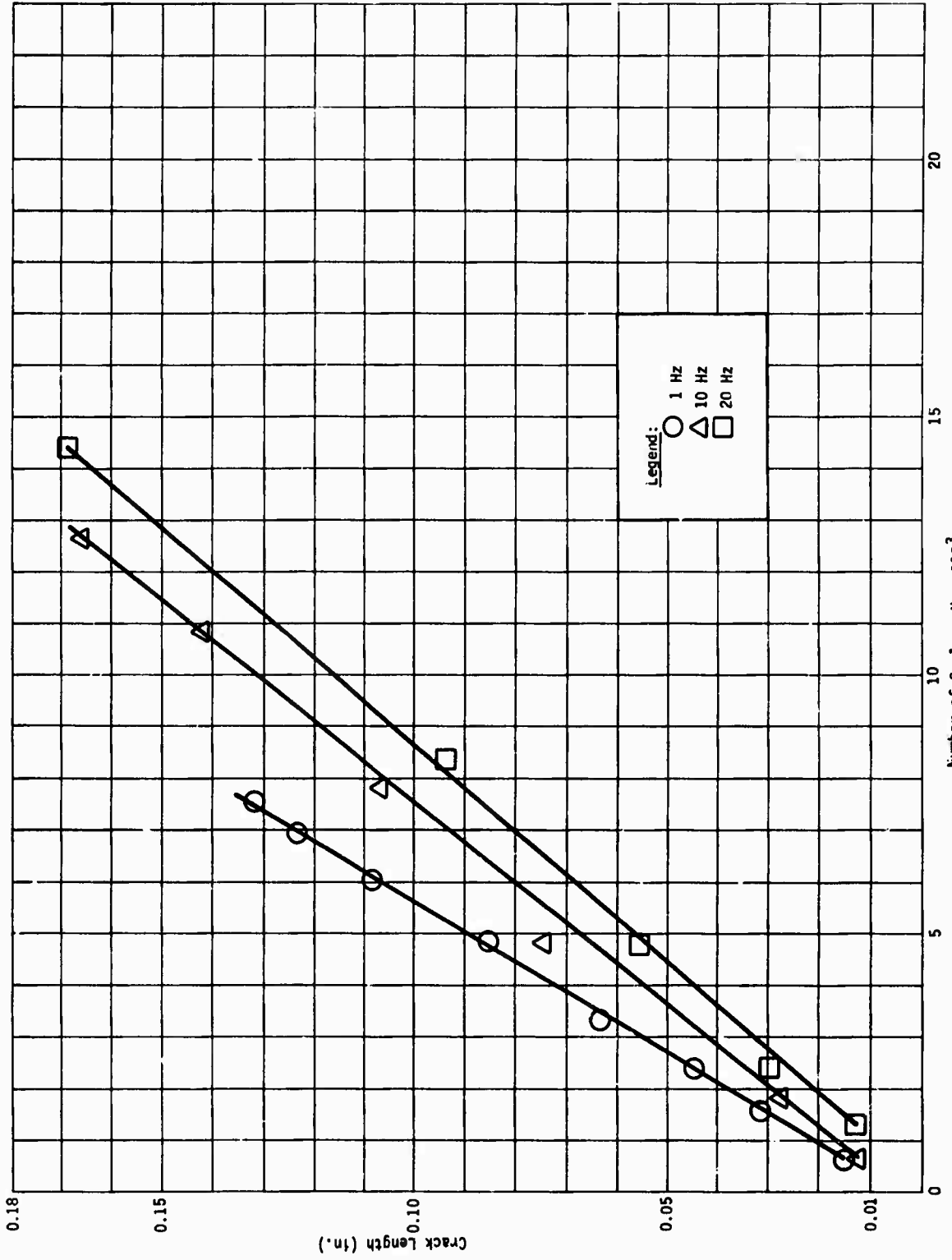

Fig. III-18 Crack Propagation Behavior of Al 2014-T6 under Plane Stress Condition, at Various Test Frequencies, Rippling Specimen 0.125-Inch-Thick

B. PLANE STRAIN TESTING

1. Aluminum 2014-T6

For measurements of the crack propagation rate of aluminum 2014-T6 under plane strain conditions a 1-inch CT specimen was used. The specimens were machined from 2.5-inch-wide strips (see Fig. II-3 for details) that had been cut from 36-inch-wide plates. For the S-SLE-treated specimens, the 2.5-inch-wide strips were prestressed to 58 ksi and then chem-milled to remove 0.005 inch from each face. The CT Specimens were machined from these 2.5-inch strips. For the untreated specimens the same treatment was used except the specimens were not prestressed.

A typical crack growth curve for the 2014-T6 aluminum specimens under plane strain condition is shown in Figure III-19. These data were obtained by cycling the specimens between load limits of 300 to 1200 pounds at 20 Hz. The crack propagation rates as a function of ΔK for the S-SLE-treated and untreated specimens are shown in Figure III-20. These curves show that the S-SLE treatments decreased the crack propagation rate by a factor of about 2. As may be seen in Figures III-19 and III-20, prestressing to about the proportional limit without removing the surface layer causes the crack resistance to decrease.

2. Titanium (6Al-4V)

For the plane strain testing of titanium (6Al-4V), CT specimens 5/8-inch thick were used. Typical crack growth curves of the untreated and S-SLE-treated specimens are given in Figure III-21. It is quite apparent that initial flaw growth did not occur in the treated specimens until about 600,000 cycles had been exceeded, whereas for the untreated specimens, cracking started below 100,000 cycles. The relationship between da/dN and ΔK is shown in Figure III-22. In these tests, the surface layer was eliminated by allowing the specimens to relax for about 18 hours. The effect of "over-stressing" on the crack growth rate is also shown in Figures III-21 and III-22. After the specimens were stressed to 131 ksi (1.5% plastic strain) and the surface layer was eliminated by relaxation, the crack growth rate was considerably greater than for the untreated and the properly treated specimens. It may also be seen that the initial flaw began to grow in relatively few cycles ($\sim 10,000$) compared to the specimens that were prestressed to 103 ksi and relaxed. The data for the relationship between da/dN and ΔK for the S-SLE specimens prestressed to 130 ksi is very limited. As shown in Figure III-21 the crack length appeared to increase in a linear fashion with increasing number of cycles. This would indicate that da/dN is constant with ΔK ; an unlikely result. More data are being obtained to obtain a more accurate relationship.

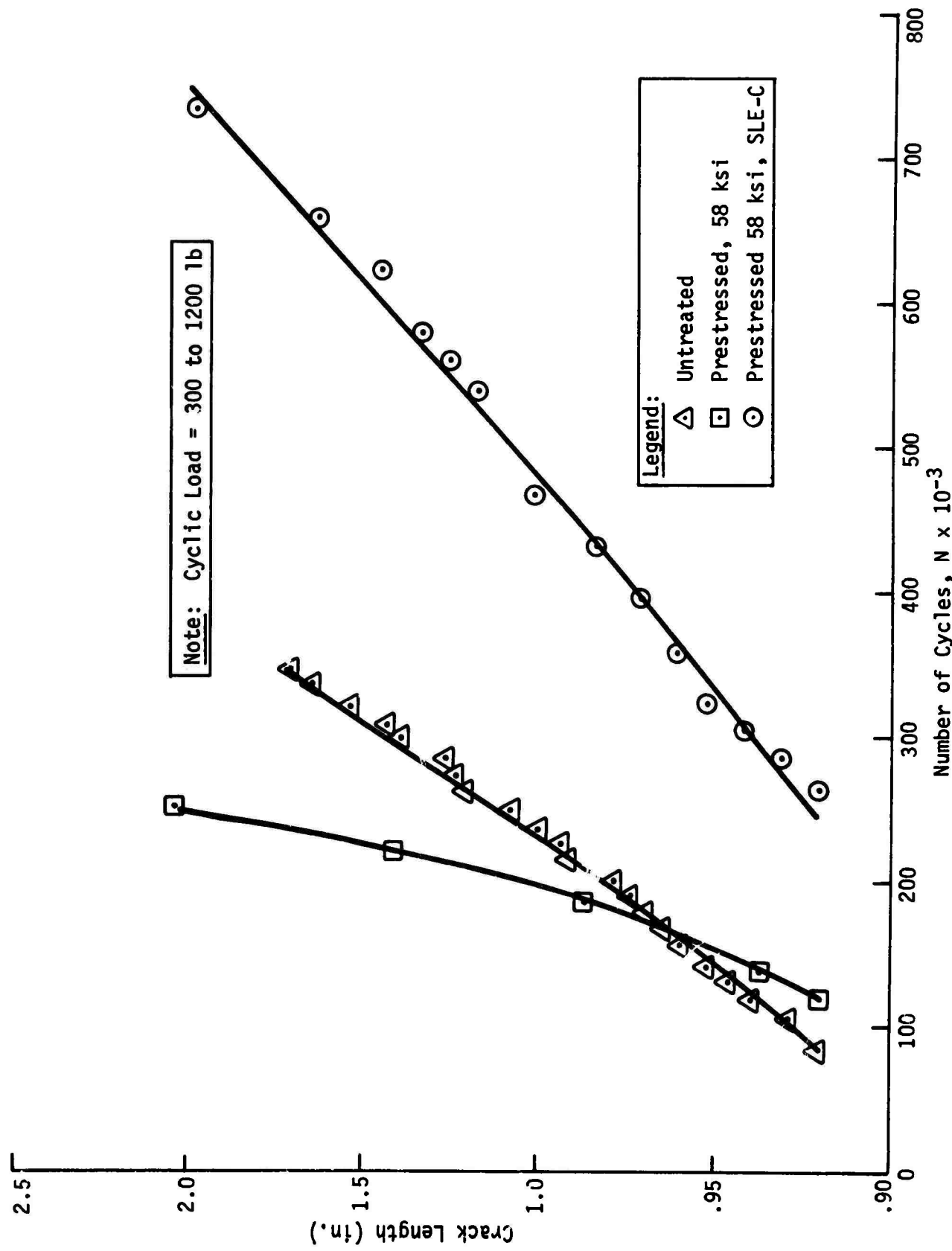

Fig. III-19 Crack Propagation Behavior of Aluminum 2014-T6 Under Plane Strain Conditions, CT Specimens 1-Inch Thick.

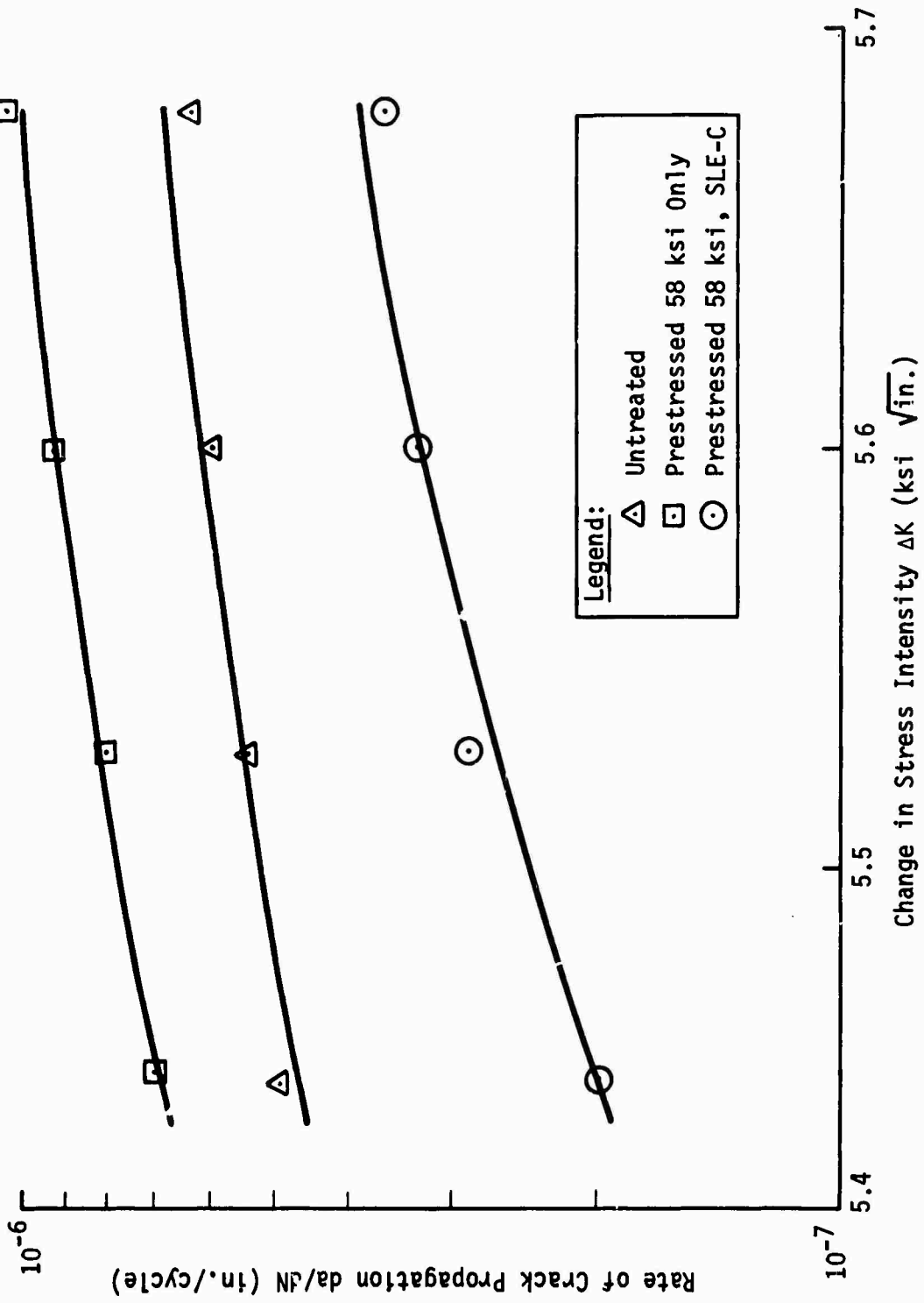

Fig. III-20 Crack Propagation Behavior of Aluminum 2014-T6 Under Plane Strain Conditions, Compact Tension Specimens 1-inch Thick.

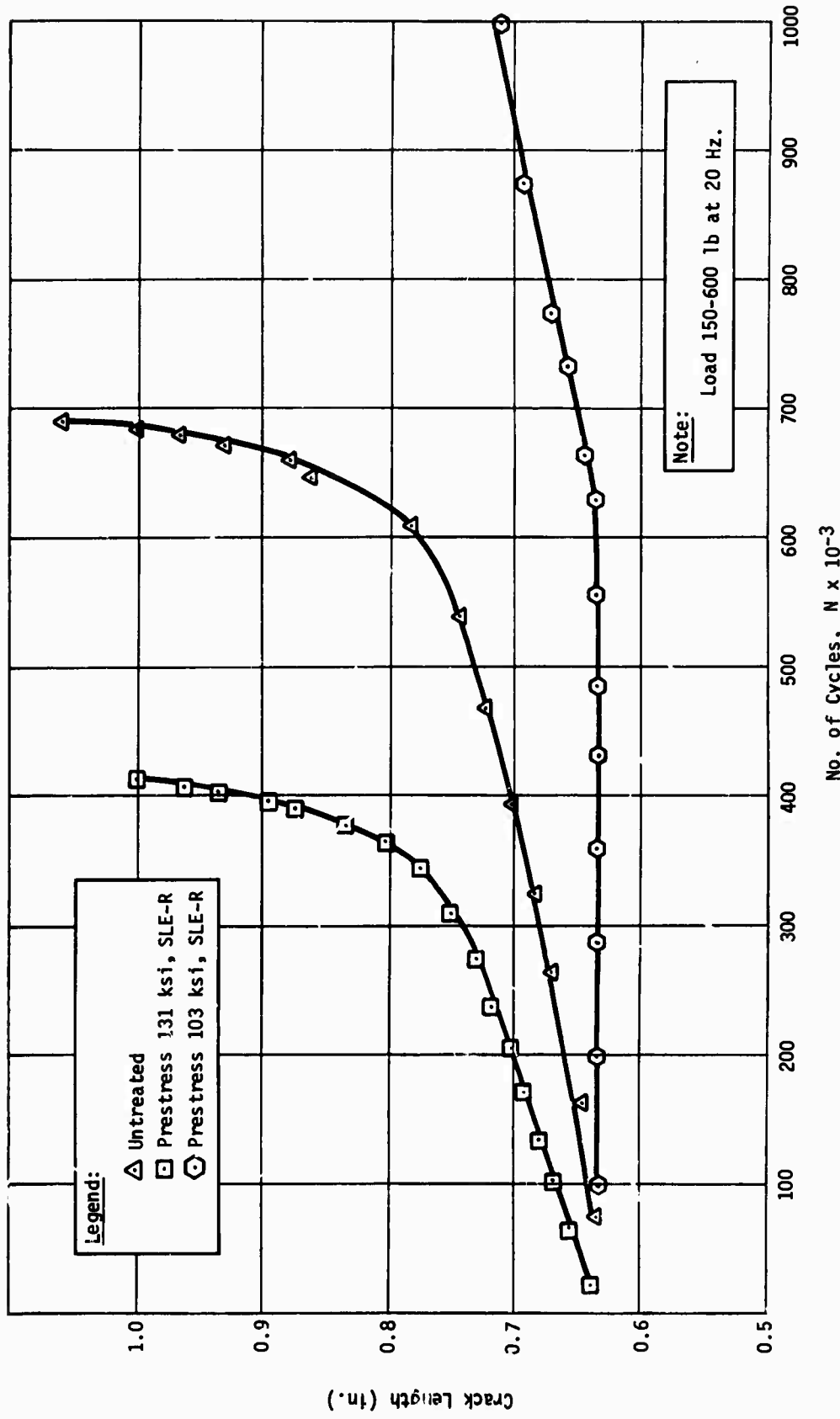

Fig. III-21 Crack Propagation Behavior of Titanium (6Al-4V) Under Plane Strain Conditions, CT Specimens 0.64-Inch Thick

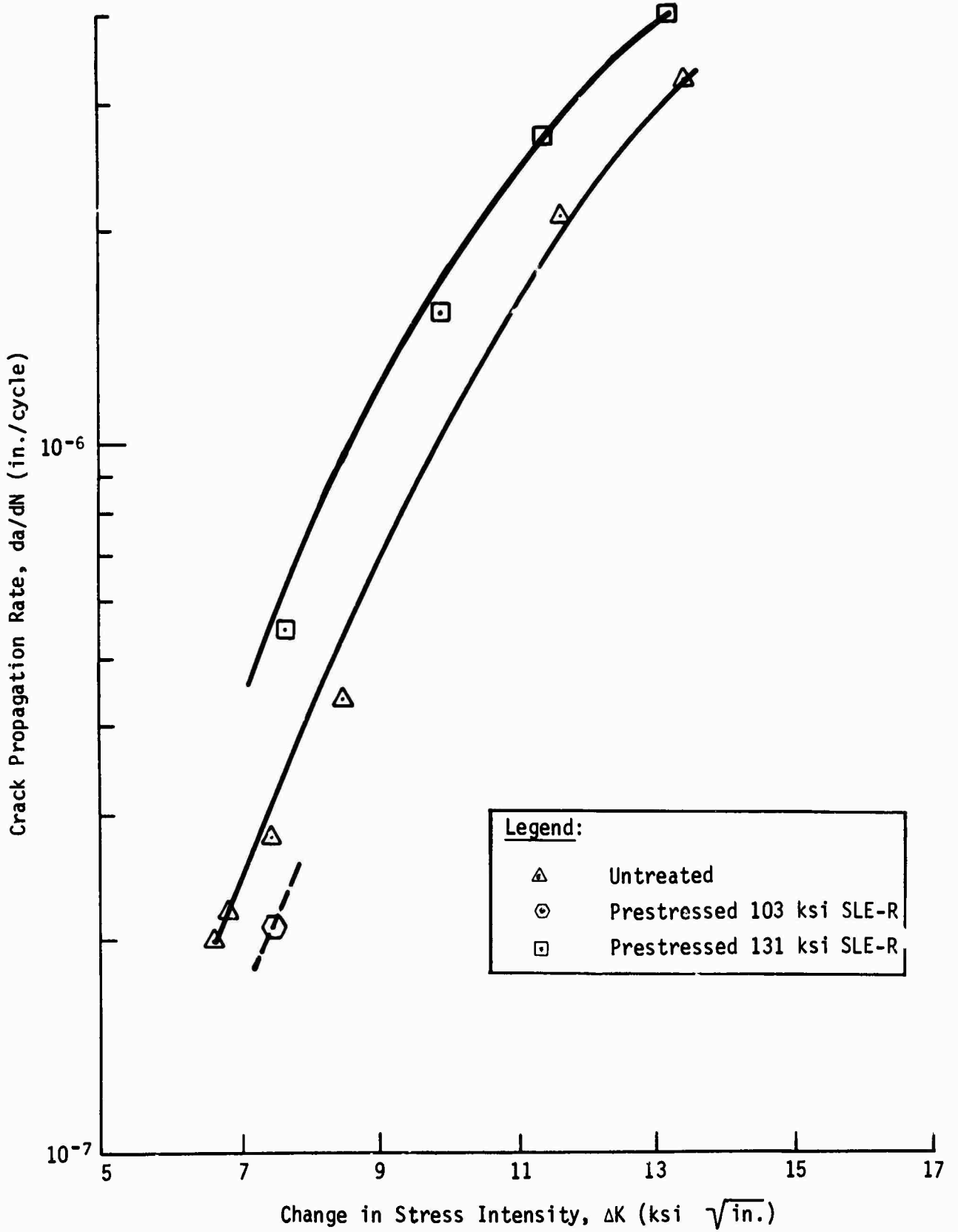

Fig. III-22 Crack Propagation Behavior of Titanium (6Al-4V) under Plane Strain Condition, Compact Tension Specimens 0.64-Inch-Thick

3. 4130 Steel

The effect of cyclic loading on precracked CT specimens of 4130 steel is shown in Figure III-23. The tests were conducted on 5/8-inch-thick specimens at 20 Hz. The CT specimens were machined from plates of 5/8-inch-thick 4130 steel which had been prestressed to 120.5 ksi. The specimens were relaxed for more than three weeks. The effect of prestressing and surface relaxation on the crack propagation behavior of 4130 steel is also shown in Figure III-23. The composite plot of da/dN and ΔK is shown in Figure III-24.

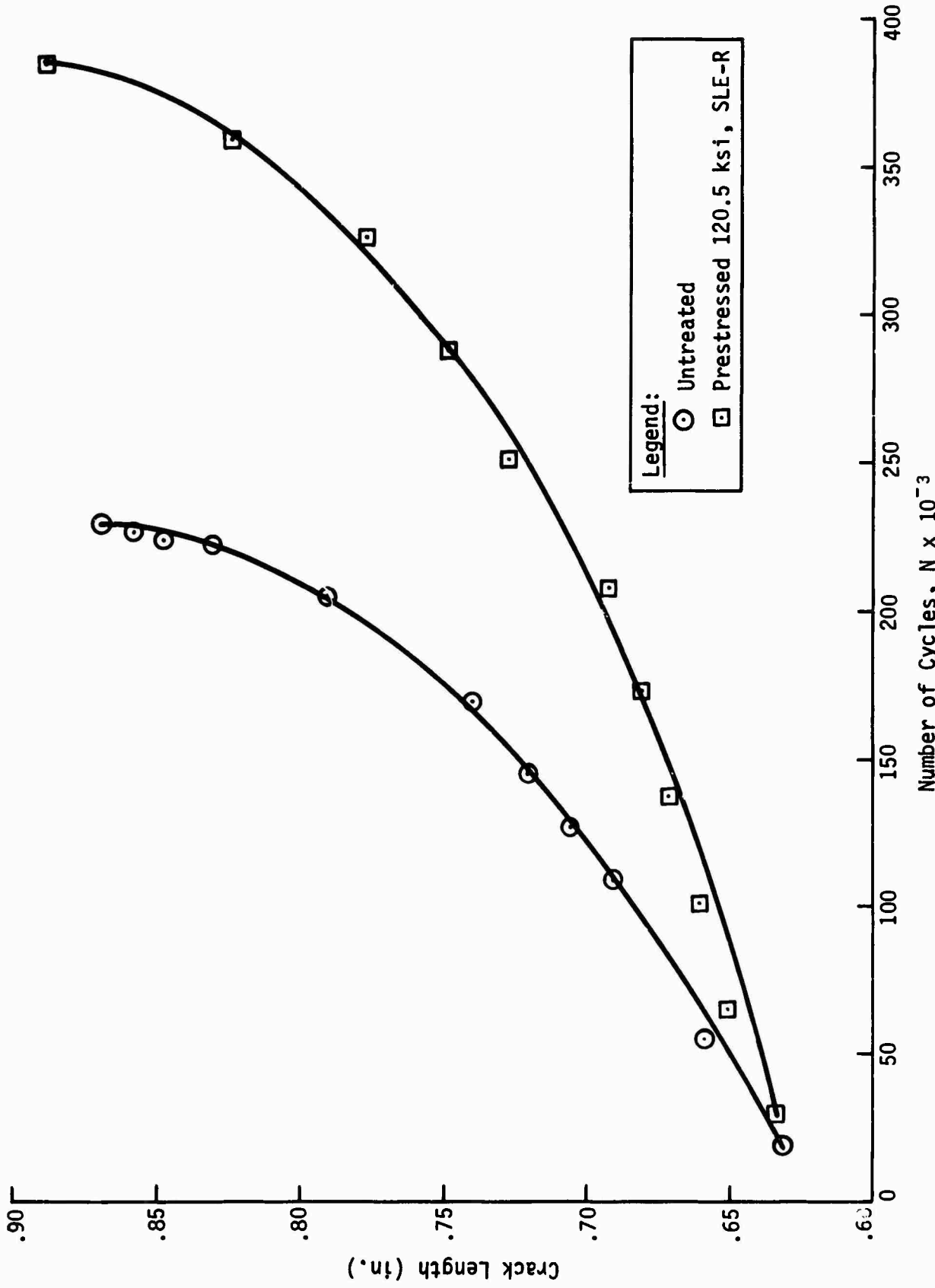

Fig. III-23 Effect of Prestress and Surface Layer Elimination on the Crack Propagation Rate of 4130 Steel under Plane Strain Condition, Compact Tension Specimens 0.625-Inch-Thick

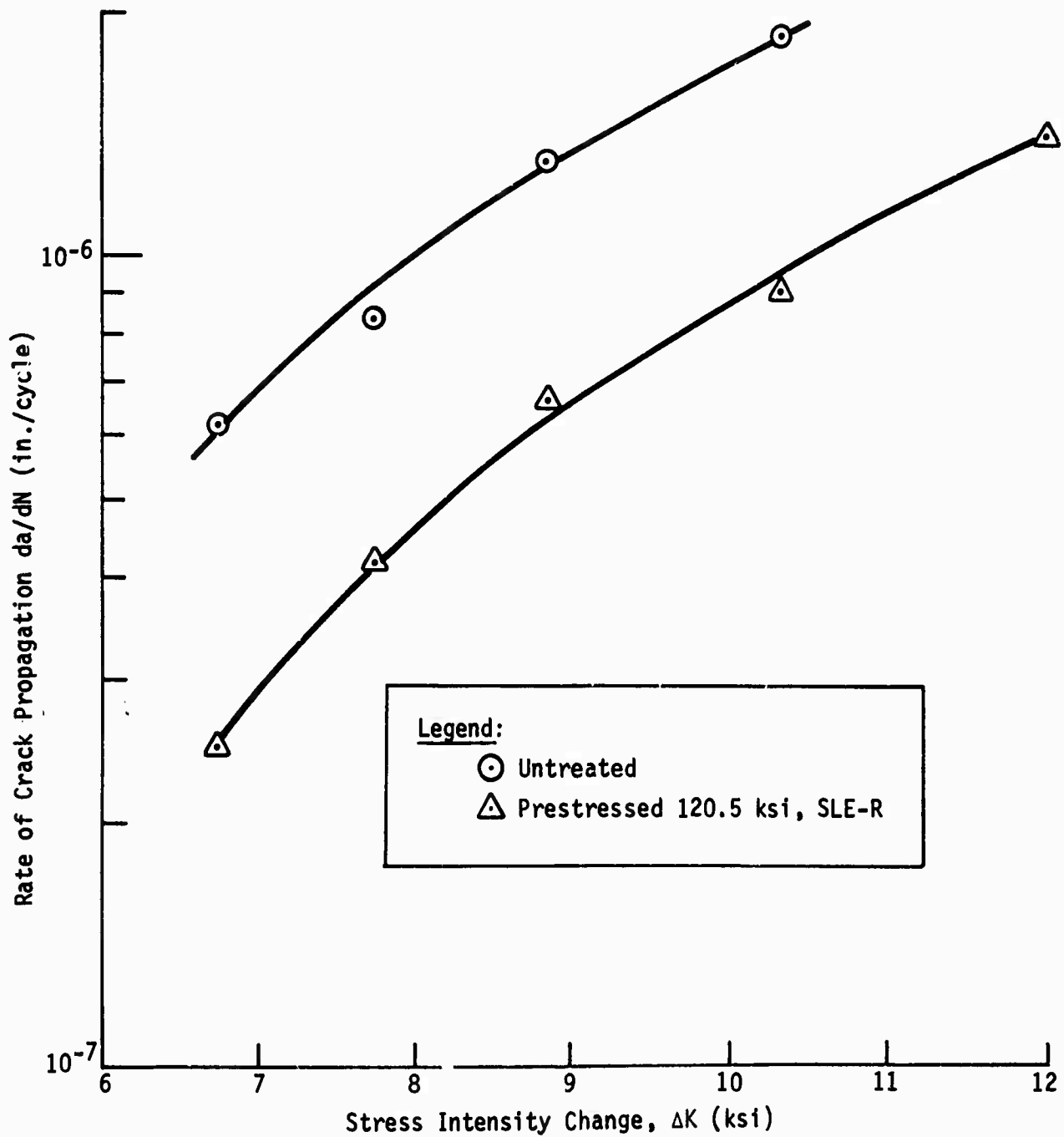

Fig. III-24 Crack Propagation Behavior of 4130 Steel,
CT Specimens, 0.625-Inch Thick

IV. DISCUSSION OF RESULTS

The data show that the crack resistance of titanium 6Al-4V, 2014-T6 aluminum and 4130 steel under both plane stress and plane strain conditions can be increased by a very simple treatment. This treatment consists of prestressing the metal to the proportional limit and then eliminating the surface layer formed as a result of this operation. This elimination may be done either by chem-milling about 0.005 inch from the surfaces or by relaxing the surface layer for a sufficiently long time. It appears that for metals strengthened by precipitation hardening, the chem-milling process must be used. The data also show that excess prestressing can be very detrimental to crack resistance. In all three metals used in this investigation, both the flaw growth initiation and crack growth rate were adversely affected by stressing into the plastic flow region. This effect was particularly noticeable for the plane strain conditions. Since this decrease in crack resistance was not ameliorated by removing the surface layer, it may be concluded that the overstressing produced damage in the interior of the specimen.

In many respects, the improvement in the crack resistance by the S-SLE treatment is similar to that obtained in fatigue tests (20) of titanium and aluminum. The results are reproduced here for convenience (Fig. IV-1 and IV-2). Both sets of tests, crack propagation and fatigue, show that the greatest improvement is obtained at the lower ΔK or stress values.

These observations are in keeping with our concept (20) that the existence of the surface layer adversely affects the crack propagation resistance. In the S-SLE treatment when the metal is prestressed to the proportional limit, all "soft" grains undergo plastic deformation. Since the constraints for plastic flow are less for the grains at or near the surface than for those in the interior, more plastic flow occurs in the surface region and a surface layer rich in dislocations may be formed. The relaxation treatment or the chem-milling operation eliminates this surface region. On reloading, under ideal conditions the surface layer will not re-form until a stress equal to the prestress minus the surface layer stress is reached. However, because of stress concentrations in front of cracks, notches, inclusions, etc., plastic flow will start at a lower stress and the surface layer will re-form in part. It is suggested that the surface layer causes a decrease in ductility by acting as barrier for a "pile-up" of dislocations of one sign. Under cyclic conditions, the surface layer can work harden if the terminal stresses are sufficiently high. When the local stress associated with the "pile up" exceeds the fracture stress then a crack will form and propagate with additional cycling. The endurance is the stress at which the surface layer does not form (or the surface layer stress increases very slowly with cycling).

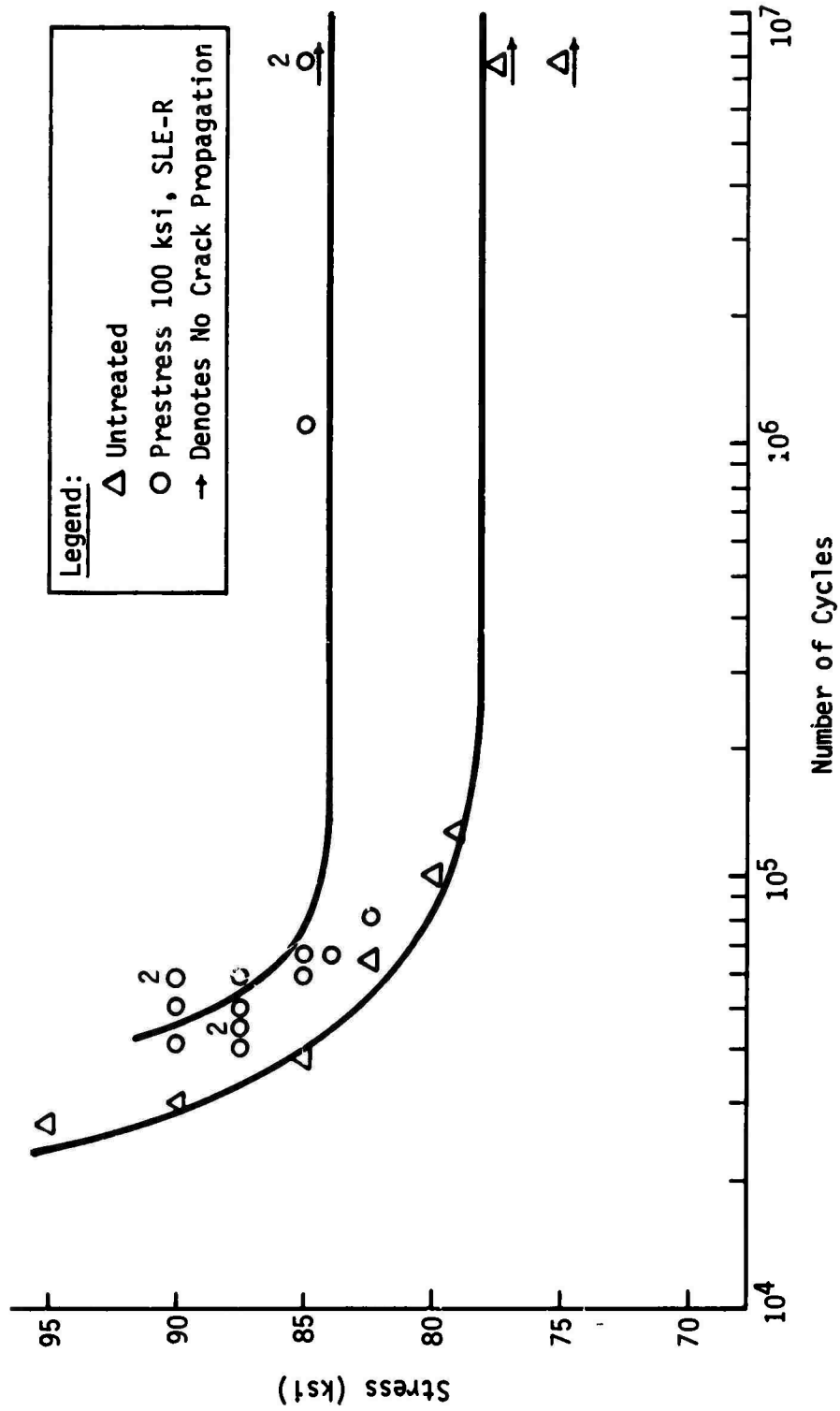

Fig. IV-1 Effect of Removal of Surface Layer on Fatigue-Life of Titanium (6Al-4V)

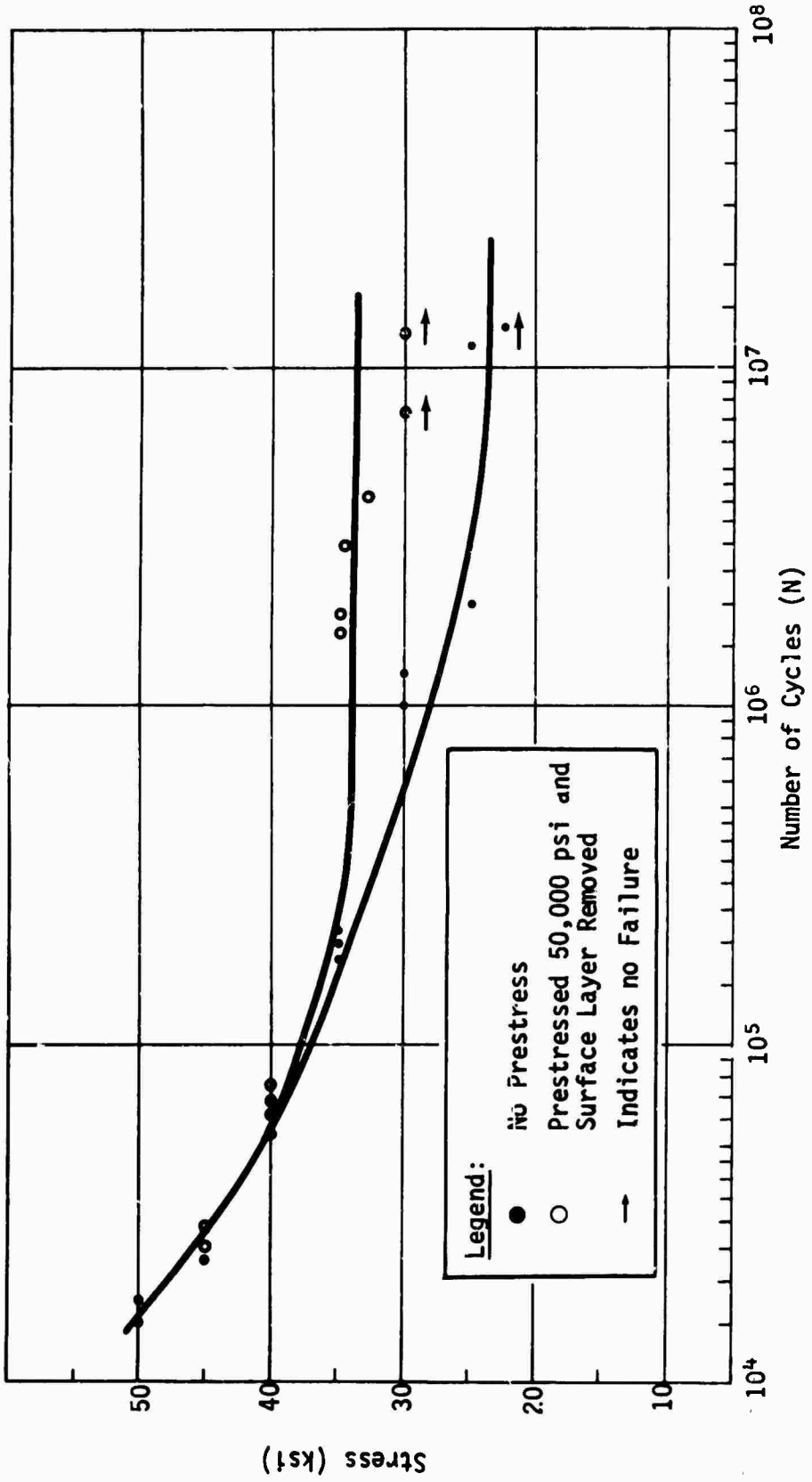

Fig. IV-2 Effect of Removal of Surface Layer on the Fatigue Life of 7075-T6 Aluminum. Tested in Tension-Compression

It was suggested (21) that the crack propagation rates, da/dN , are related to the change in the stress intensity factor by the expression

$$\frac{da}{dN} = C\Delta K^n \quad [6]$$

where C and n are constants. These data show that in accordance with equation [6], a straight line is obtained when $\log \Delta K$ is plotted with respect to $\log da/dN$. A typical example is shown in Figure IV-3 for 4130 steel under plane strain conditions. It may be seen that for the two cases, untreated and S-SLE-treated, the slopes n are equal but C , the intercept of da/dN at $\Delta K = 1$ is much less for the S-SLE-treated specimens. However, for the plane stress condition for the aluminum alloy, both n and C are affected. A summary of n and C for the various metals under plane stress and plane strain conditions is given in Table IV-1. Table IV-1 shows that the S-SLE treatment not only changes C by a factor of 1000 but also changes n . In most of the models proposed to describe fracture mechanics behavior, C and n are said to be functions of E , σ_y , ϵ_f and K_{Ic} where E is the modulus, σ_y is the yield strength and ϵ_f is the strain to fracture. If surface layer effects are ignored, it is very unlikely that these parameters can change by prestress alone to cause a decrease in C by a factor of 1000 and an increase in n by a factor of 3. It therefore is evident that crack propagation theories must be modified to take surface layer effects into account.

Table IV-1 Summary of Crack Propagation Data for Materials

| MATERIAL | THICKNESS (in.) | TREATMENT | n | C |
|-------------------|-----------------|-----------|------|-----------------------|
| Aluminum 2014-T6 | 0.125 | Untreated | 4.3 | 1.9×10^{-9} |
| Aluminum 2014-T6 | 0.125 | S-SLE | 8.0 | 3.0×10^{-12} |
| Aluminum 2014-T6 | 1.0 | Untreated | 5.7 | 2.8×10^{-11} |
| Aluminum 2014-T6 | 1.0 | S-SLE | 16.8 | 1.1×10^{-11} |
| Titanium (6Al-4V) | 0.067 | Untreated | 3.8 | 2.1×10^{-10} |
| Titanium (6Al-4V) | 0.067 | S-SLE | 6.1 | 3.1×10^{-13} |
| Titanium (6Al-4V) | 0.625 | Untreated | 6.5 | 2.2×10^{-13} |
| Titanium (6Al-4V) | 0.625 | S-SLE | | |
| 4130 Steel | 0.125 | Untreated | 2.5 | 5.6×10^{-9} |
| 4130 Steel | 0.125 | S-SLE | 3.0 | 6.4×10^{-10} |
| 4130 Steel | 0.625 | Untreated | 3 | 2×10^{-9} |
| 4130 Steel | 0.625 | S-SLE | 3 | 7.9×10^{-10} |

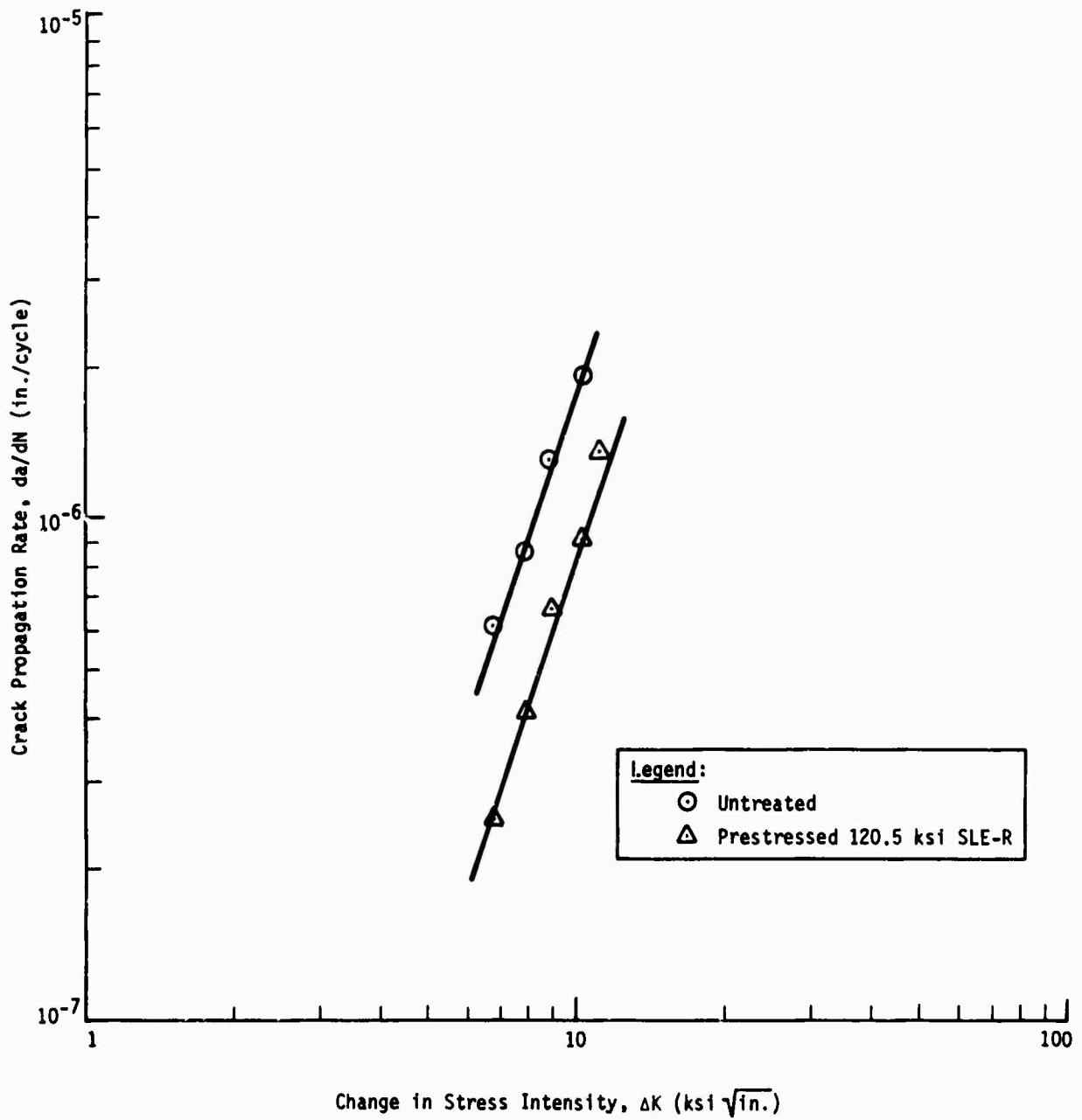

Figure IV-3 Crack Propagation Behavior of 4130 Steel Under Plane Strain Condition, CT Specimens 0.625-Inch Thick

It is believed to be of interest to show how the S-SLE treatment affects the crack propagation rate when the tests are conducted in an environment that causes corrosion fatigue. The data presented in Figure IV-4 are for titanium (6Al-4V) tested in a methanol-HCl solution (22). These data show that, similar to the crack propagation rates obtained for tests conducted in air, the S-SLE treatment improves the corrosion fatigue resistance, especially at the lower ΔK values. Thus, the S-SLE treatment increases the crack resistance of metals in both air and in the corrosion fatigue environments.

Since the S-SLE treatment could be expected to influence the deformation characteristics on a microscopic level, a number of electron fractographs of treated and untreated specimens of titanium and aluminum were made. Typical fractographs of the titanium and aluminum alloys are given in Figures IV-5 and IV-6. Figure IV-5 shows that for the titanium alloy under plane stress conditions (specimen thickness 0.067 in.) the fracture surface of the S-SLE-treated specimens contained many more dimpled areas than the fractured surfaces of the untreated specimens. This reflects the improved ductility of the treated specimens. For the plane strain condition, the fractograph given in Figure IV-6 for 2014-T6 aluminum shows that the number of river lines is far less in the S-SLE-treated specimens than in the untreated specimens, again indicating that the treatment results in a more ductile fracture and thus a slower rate of crack propagation.

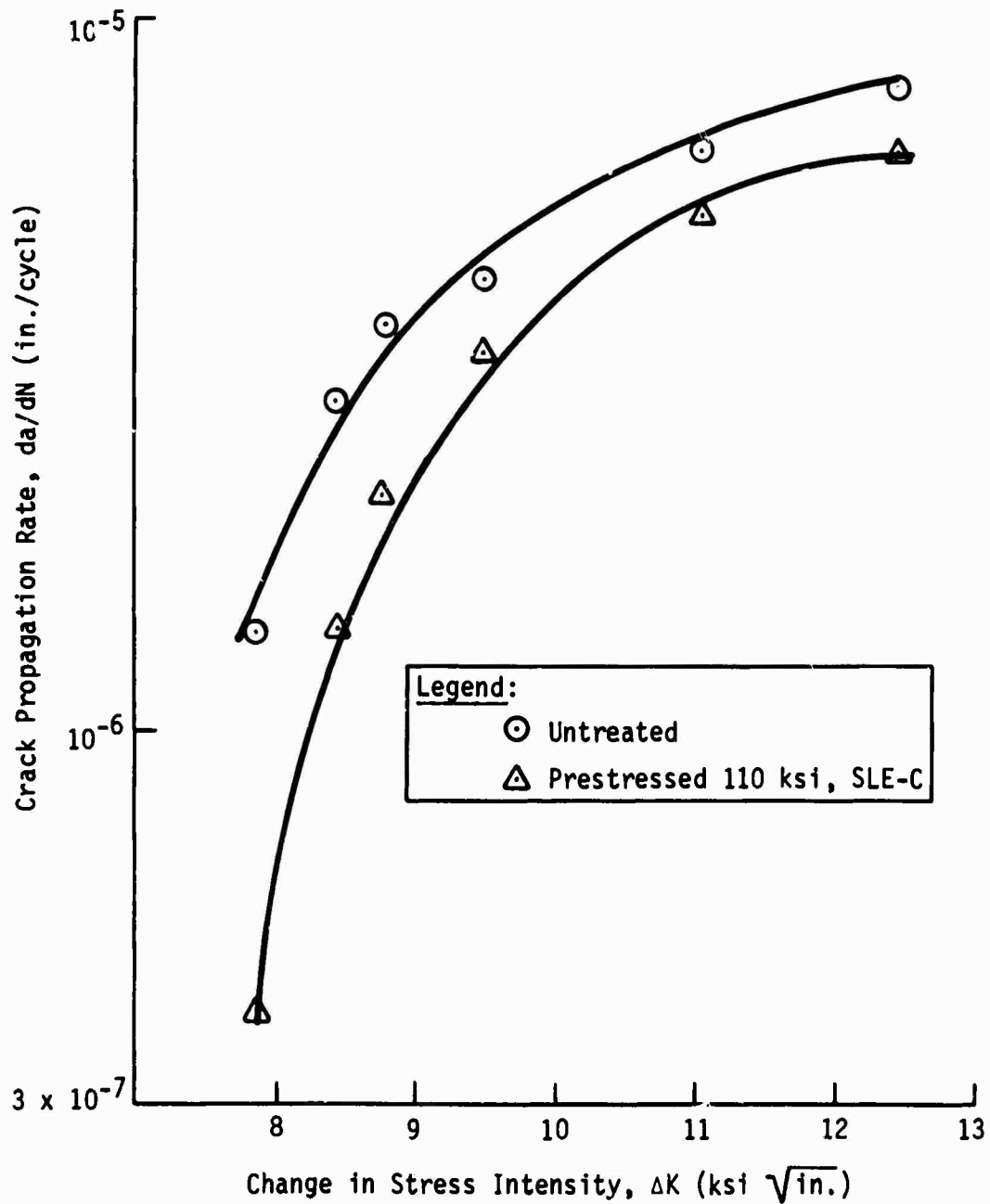
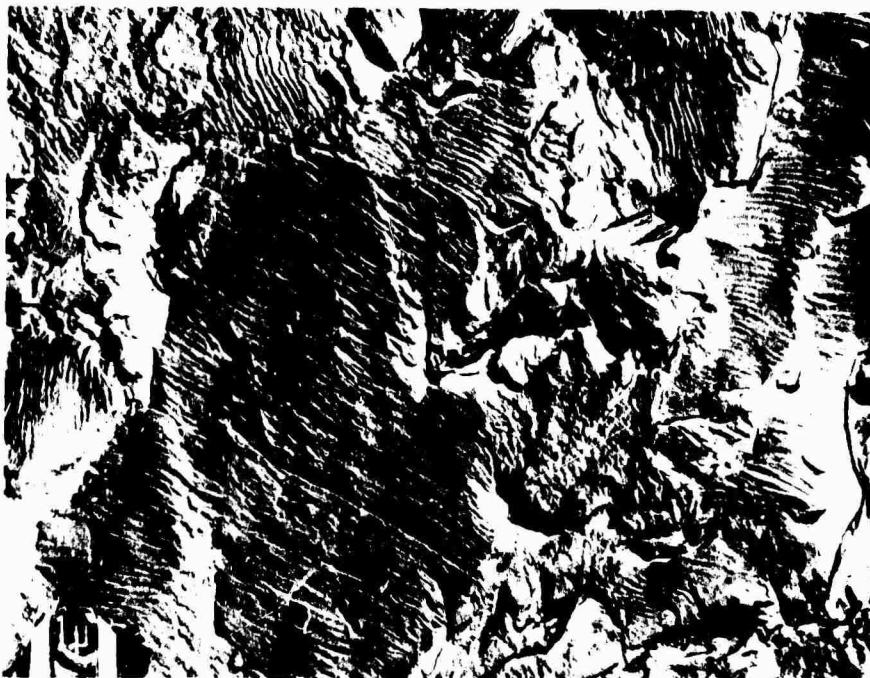

Fig. IV-4 The Effect of Prestress and Surface Removal Treatment on Crack Propagation Behavior of Titanium (6Al-4V) under Plane Strain Conditions in Methanol-Chloride Environment, Center-Cracked Specimens 0.067-inch Thick



(a) Untreated

NOT REPRODUCIBLE



(b) SSR-Treated

NOT REPRODUCIBLE

Fig. IV-5 Electron Fractographs of (a) Untreated and (b) S-SLE-Treated Titanium (6Al-4V) Specimens Tested in Air under Plane Stress



(a) Untreated

NOT REPRODUCIBLE

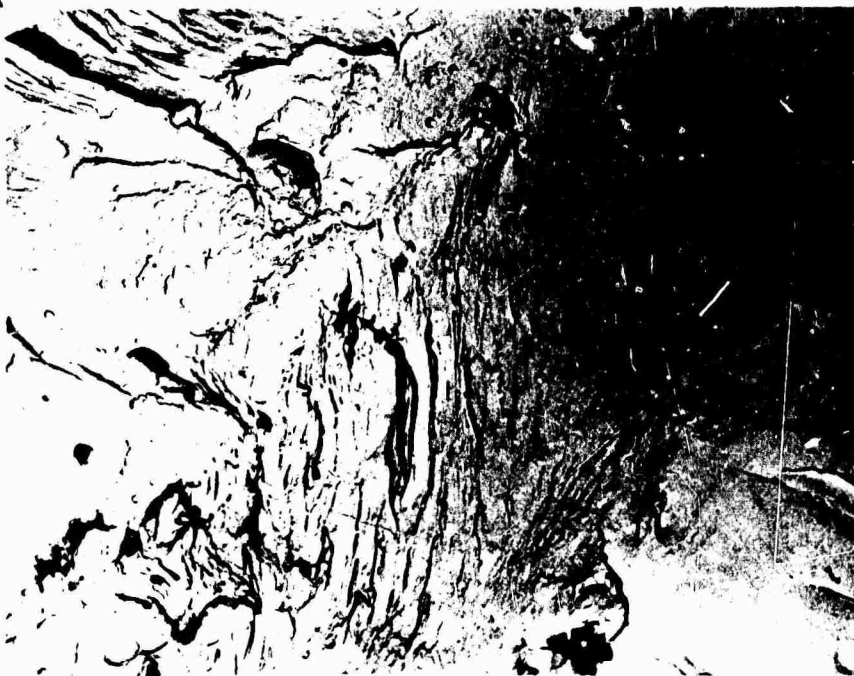

(b) Treated

Fig. IV-6 Electron Fractograph of (a) Untreated and (b) S-SLE-Treated Aluminum 2014-T6 Specimens Tested in Air under Plane Strain Conditions

V. SUMMARY

An investigation was conducted to determine the effect of prestress and surface removal treatment on the rate of crack propagation in three materials -- titanium (6Al-4V), aluminum 2014-T6, and 4130 steel. The cyclic loading tests were conducted at room temperature at 20 Hz with a ratio R of minimum to maximum stress intensity equal to 0.25. Center-cracked specimens were used for plane stress testing while compact tension specimens were used for plane strain testing. For plane stress testing, the thickness for the titanium (6Al-4V) was 0.067 inch while that for aluminum 2014-T6 and 4130 steel was 0.125 inch. One-inch-thick specimens were used for aluminum 2014-T6 to satisfy the ASIMs criteria for plane strain testing. The thickness used for plane strain testing of titanium (6Al-4V) and 4130 steel was 0.625 inch. While a few plane stress measurements were made of the flared double cantilever beam (Ripling) specimen, the specimen was found to be unsatisfactory because of the extreme grooving necessary to keep the crack in a straight line. Prestressing below the yield followed by surface removal decreased the crack propagation rate at lower stress intensity levels under plane stress as well as plane strain conditions. Prestressing aluminum 2014-T6 below the proportional limit markedly increased the crack propagation rate when the resulting surface layer was not removed. Accordingly, proof testing of structures of this type of alloy should be avoided.

VI. REFERENCES

1. I. R. Kramer: *Trans AIME*, 233, 1462, 1965.
2. I. R. Kramer: *Trans AIME*, 239, 520, 1967.
3. I. R. Kramer: *Environment-Sensitive Mechanical Behavior of Materials*, Breach and Gordon, 1967, p 127.
4. J. E. Dorn: *Dislocation Dynamics*, McGraw-Hill Book Company, 1968, p 27.
5. I. R. Kramer: *Fundamental Phenomena in the Materials Sciences*, Plenum Press, 1966, p 171.
6. S. Kitajima, H. Tanaka, and H. Kaleda: *Trans JIM*, 10, 10, 1969.
7. T. Suzuki: *Dislocations and Mechanical Properties of Crystals*, John Wiley and Sons Inc., 1956, p 215.
8. G. Vellaikal and J. Washburn: *Journal Applied Physics*, 40, 2280, 1969.
9. R. J. Block and R. M. Johnson: *Acta Met*, 17, 299, 1969.
10. J. T. Fourie: *Phil. Mag.* 17, 735, 1968.
11. I. R. Kramer and C. L. Haehner: *Acta Met*, 15, 199, 1967.
12. T. V. Cherian, P. Pietrokowsky, and J. E. Dorn: *Trans AIME*, 185, 948, 1949.
13. P. A. Rehbinder: *Byul. Akad. Nauk Classe, Sci. Mat. Nat. Ser. Chem.*, 639, 1936.
14. H. Shen and I. R. Kramer: *Trans. Int. Vacuum Metallurgy Conference*, New York, 1967, p 263.
15. I. R. Kramer and S. E. Podlaseck: *Acta Met*, 11, 70, 1963.
16. P. T. Gilbert: "Corrosion Fatigue," *Metallurgical Reviews*, 1, 379, 1956.
17. E. N. Pugh and A. J. Sedriks: *Surfaces and Interfaces*, Vol II, Syracuse University Press, 1968, p 183.

18. S. Mostovoy, P. B. Crosley, and E. J. Ripling: *Journal of Materials*, 2, 661, 1967.
19. E. T. Wessel: *Eng. Frac. Mech.*, 1, 77, 1968.
20. I. R. Kramer: "The Effect of the Surface Layer and Environment on Cyclic Behavior and Fatigue of Metals." *Proceedings of the Air Force Conference on Fatigue and Fracture of Aircraft Structures and Materials*. Miami Beach, Florida, December 1969.
21. P. C. Paris: *Fatigue - An Interdisciplinary Approach*, Syracuse University Press., 107, 1964. (J. J. Burke et al. Editors)
22. I. R. Kramer and A. Kumar: "The Influence of Environment and Surface Layer on CRack Propagation and Cyclic Behavior." Paper presented at the International Conference on Corrosion Fatigue held in Storrs, Connecticut, June 14, 1971. (Proceedings to be published and work done also to be published, under Contract F44640-69-C-0065)