

RADC-TR-71-230
Final Technical Report
August 1971



Prepared By
Rome Air Development Center
Air Force Systems Command
Griffiss Air Force Base, New York 13440

AD 731 860

PROJECT SECEDE

SECEDE LASER RADAR EXPERIMENT

Avco Everett Research Laboratory

Reproduced by
NATIONAL TECHNICAL
INFORMATION SERVICE
Springfield, VA 22151

Sponsored by
Advanced Research Projects Agency
ARPA Order No. 1057, Amendment No. 15

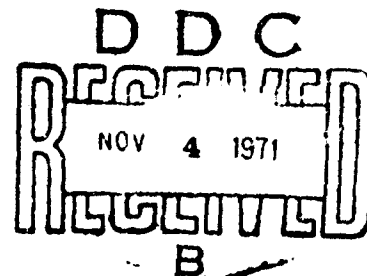

Approved for public release;
distribution unlimited.

The views and conclusions contained in this document are those of the authors and should not be interpreted as necessarily representing the official policies, either expressed or implied, of the Advanced Research Projects Agency or the U. S. Government.

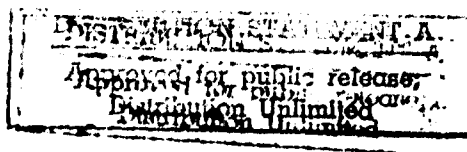

UNCLASSIFIED

Security Classification

DOCUMENT CONTROL DATA - R & D

(Security classification of title, body of abstract and indexing annotation must be entered when the overall report is classified)

1. ORIGINATING ACTIVITY (Corporate author) AVCO-Everett Research Laboratory 2385 Revere Beach Parkway Everett, MA		2a. REPORT SECURITY CLASSIFICATION UNCLASSIFIED	
		2b. GROUP	
3. REPORT TITLE SECEDE LASER RADAR EXPERIMENT			
4. DESCRIPTIVE NOTES (Type of report and inclusive dates) Final Technical Report			
5. AUTHOR(S) (First name, middle initial, last name) Itzkan, I., DeBaryshe, P.G. and Kirk, R.A.			
6. REPORT DATE August 1971	7a. TOTAL NO. OF PAGES 41	7b. NO. OF REFS 1	
8a. CONTRACT OR GRANT NO. F30602-71-C-0025	9a. ORIGINATOR'S REPORT NUMBER(S)		
b. PROJECT NO. ARPA Order 1057			
c. Program Code No.: OE 20	9b. OTHER REPORT NO(S) (Any other numbers that may be assigned this report) RADC-TR-71-230		
d.			
10. DISTRIBUTION STATEMENT Approved for Public Release, Distribution Unlimited.			
11. SUPPLEMENTARY NOTES Monitored by: William H. Dungey, 1/Lt RADC/CCSE Griffiss AFB NY 13440		12. SPONSORING MILITARY ACTIVITY Advanced Research Project Agency 1400 Wilson Blvd. Arlington, VA 22209	
13. ABSTRACT In support of the SECEDE II barium release test series, AVCO-Everett Research Lab. conducted an experiment to demonstrate the feasibility of making measurements of spatial density distribution in a barium ion cloud. The feasibility measurements were made with a laser radar breadboard which transmits laser pulses at the wavelengths of the 4934 A° ion ground state resonance line, and detects the return signals by means of a collecting telescope and photomultiplier, all mounted on an alt-azimuth platform. A videotape recorder was used to record the time resolved return signals, and a boresight camera was used to record pointing information. Provisions were included for control, display and field calibration of the system. Preliminary reductions and evaluation of a small fraction of the tape recorder data has been accomplished. The purpose of this evaluation was primarily to determine an optimum technique for reduction of the data which is contained on seven rolls of magnetic tape and five rolls of film, and secondarily, to observe if laser return was present in the data examined. Approximately 8-3/4 minutes of the tape record of Event Olive was examined reasonably carefully and approximately 2-1/2 minutes of data from Event Spruce was examined in a cursory fashion. There is no return obvious in the Olive data. The Spruce data seems to indicate that laser return is present in the video tape record; however, the data processing was too crude to provide statistically convincing evidence. Further reduction of the Spruce data is certainly warranted.			

DD FORM 1473
1 NOV 65

UNCLASSIFIED

Security Classification

When US Government drawings, specifications, or other data are used for any purpose other than a definitely related government procurement operation, the government thereby incurs no responsibility nor any obligation whatsoever; and the fact that the government may have formulated, furnished, or in any way supplied the said drawings, specifications, or other data is not to be regarded, by implication or otherwise, as in any manner licensing the holder or any other person or corporation, or conveying any rights or permission to manufacture, use, or sell any patented invention that may in any way be related thereto.

CFSTI	UNCLASSIFIED	<input checked="" type="checkbox"/>
DDC	REF SECTION	<input type="checkbox"/>
UNCLASSIFIED		<input type="checkbox"/>
JUSTIFIED		
BY		
DISTRIBUTION/AVAILABILITY CODES		
DIST.	AVAIL.	SPECIAL
A		

If this copy is not needed, return to RADG (OCSE), GAFB, NY 13440.

14 KEY WORDS	LINK A		LINK B		LINK C	
	ROLE	WT	ROLE	WT	ROLE	WT
1. Laser Radar (Lidar)						
2. Dye Laser						
3. Resonant Scattering						
4. Narrow Wavelength Dye Laser						
5. Barium Release						

SECEDE LASER RADAR EXPERIMENT

Dr. I. Itzkan
P. G. DeBaryshe
R. A. Kirk

Contractor: Avco Everett Research Laboratory
Contract Number: F30602-71-C-0025
Effective Date of Contract: 15 April 1970
Contract Expiration Date: 15 April 1971
Amount of Contract: \$194,676.00
Program Code Number: OE20

Principal Investigator: Dr. Irving Itzkan
Phone: 617 389-3000 Ext. 438

Project Engineer: Vincent J. Coyne
Phone: 315 330-3107

Contract Engineer: Lt William H. Dungey
Phone: 315 330-3443

Approved for public release;
distribution unlimited.

This research was supported by the
Advanced Research Projects Agency
of the Department of Defense and
was monitored by Lt William W. Dungey
RADC (OCSE) GAFB, NY 13440, under
contract F30602-71-C-0025, Amendment
No. 15.

PUBLICATION REVIEW

This technical report has been reviewed and is approved.

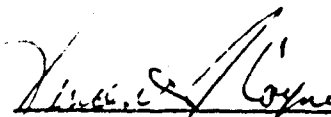
RADC Project Engineer

RADC Contract Engineer

ABSTRACT

In support of the Secede II barium release test series, Avco Everett Research Laboratory conducted an experiment to demonstrate the feasibility of making measurements of spatial density distribution in a barium ion cloud. The feasibility measurements were made with a laser radar breadboard which transmits laser pulses at the wavelength of the 4934 Å ion ground state resonance line, and detects the return signals by means of a collecting telescope and photomultiplier, all mounted on an alt-azimuth platform. A videotape recorder was used to record the time resolved return signals, and a boresight camera was used to record pointing information. Provisions were included for control, display and field calibration of the system.

Preliminary reduction and evaluation of a small fraction of the tape recorder data has been accomplished. The purpose of this evaluation was primarily to determine an optimum technique for reduction of the data which is contained on seven rolls of magnetic tape and five rolls of film, and, secondarily, to observe if laser return was present in the data examined. Approximately 8-3/4 minutes of the tape record of Event Olive was examined reasonably carefully and approximately 2-1/2 minutes of data from Event Spruce was examined in a cursory fashion. There is no return obvious in the Olive data. The Spruce data seems to indicate that laser return is present in the video tape record; however, the data processing was too crude to provide statistically convincing evidence. Further reduction of the Spruce data is certainly warranted.

TABLE OF CONTENTS

	<u>Page</u>
Abstract	iii
I. INTRODUCTION	1
II. INSTRUMENTATION	5
III. SYSTEM ASSEMBLY, CALIBRATION, AND CHECKOUT	15
IV. FIELD REPAIRS, ALIGNMENT AND CALIBRATION	17
V. SECEDE II OPERATIONS	21
VI. LABORATORY DATA ANALYSIS	31
VII. CONCLUSIONS AND RECOMMENDATIONS	39
ACKNOWLEDGMENT	39
REFERENCE	41

I. INTRODUCTION

A. Background

Extensive measurements of high altitude barium releases in the presence of sunlight have given considerable information on the shapes of the neutral and ionized barium clouds as well as their motion in the atmosphere. In early times both the neutral and ionized clouds have simple shapes and can be explained in terms of diffusion away from the initial core. Sunlight ionizes the neutral barium in a multistep process. Calculation of the rate of ionization of the barium has proved difficult because large barium clouds are optically thick (in the important absorbing lines) to the solar radiation. Thus one cannot calculate the ionization distribution even for the simple shape during the quiescent early times.

Measurements of peak ionization levels in the clouds can be obtained by radar reflections at a series of frequencies; however, the radar cannot determine the position nor size of the ionized clouds. Optical measurements of the scattered sunlight obtained with radiation that is not optically thick give more information; however, even these measurements are limited in that they furnish integrated densities along the line of sight. It is difficult to obtain detailed structure, since the detailed concentrations can only be obtained by an Abell-type inversion analysis which unfortunately requires cylindrical symmetry.

A laser radar experiment, operating at a wavelength where the cloud is optically thin, possesses the advantages of both--it can give detailed information about the ionization levels and cloud structure internal to the cloud.

The purpose of this contract was to build a breadboard model of such a laser experiment to be performed on the barium cloud in order to measure the detailed spatial density distribution of the ion clouds. The basic idea of the experiment is as follows:

A laser tuned to the frequency of one of the barium ion ground state resonance lines at 4934 \AA sends a short light pulse of several nanosecond duration towards the barium cloud. The pulse is about one meter in length along the direction of propagation. The laser light is scattered by the ions in the cloud as is sunlight, returning some of the radiation to a detector near the laser. Because of the short pulse length, one can use the round trip time of flight of the light to determine the distance between the laser system and any point in the cloud. This is identical to radar ranging systems, in which a short duration pulse is transmitted and the distance to the target is determined by the echo time lapse. For a cloud 10 km in diameter, the laser beam return from the cloud occurs over a 70 microsecond time duration. Thus, by measuring the intensity variation with time from the start of the laser pulse one can get a detailed measurement of the ionization concentration all along the line of sight of the laser beam. The width of the laser beam as it propagates through the cloud is 20 meters in diameter; therefore, considerable detailed information can be obtained about the ion cloud structure.

The laser system which we used was a combination of the nitrogen laser which generates a short light pulse at 3371 \AA followed by a dye which converts the 3371 \AA light to any longer wavelength desired. The dye 3-Aminophthalimide was used to produce laser radiation at 4934 \AA .

A typical dye fluoresces over a bandwidth of 300 \AA and can be made to lase anywhere within most of its fluorescent bandwidth. The actual lasing wavelength and the spectral width of the laser source are determined by the optical components which determine the laser cavity. Using a diffraction grating in a Littrow configuration, we have been able, by tilting the grating, to tune the laser over the fluorescent range of the dye and narrow the bandwidth to about 4 \AA . Further narrowing which is necessary for the experiment, required additional elements within the dye laser cavity such as one or more tilted Fabry-Perot interferometers. In order to select a particular hyperfine line and remain tuned to the desired line, the laser was continually monitored and manually stabilized.

Since some power is lost in the frequency narrowing process, the power was recovered by using a second dye laser as an amplifier.

B. Objectives

The major objective of this effort was the three dimensional measurements of the Barium Ion Concentrations in support of SECEDE II/V experiments using a laser illumination technique.

In order to accomplish this objective we designed, fabricated and assembled a mechanical/optical breadboard model which directed a laser beam at the barium ion cloud and recorded the signal return. The model included a photometer with 16" diameter receiving optics, azimuth and elevation pointing mechanisms, a boresight camera, a visual sight, and a laser beam collimator. (A breadboard model is an assembly of preliminary circuits and parts to prove the feasibility of a device, circuit, or principle in its simplest possible form.)

We also designed, fabricated and assembled a data recording system which recorded the signal return and time.

We also developed a dye laser with a wavelength spread of 0.025 \AA at the barium hyperfine ion line, a pulse rate of 120 pulses per second and an average power of 5 milliwatts in the laboratory, and 2 milliwatts in the field.

We integrated the mechanical/optical data recording and dye laser subsystems into a field system for the measurement of the barium cloud ion concentration. Field calibrations of the apparatus were performed. We conducted field measurements during the SECEDE II/V test series at Eglin AFB, Florida, in January 1971.

We performed preliminary data reduction on the data obtained on the SECEDE II/V tests and have included the results in this report.

This report also contains a description of the instrumentation, a description of the system check-out in the laboratory prior to field operations and a description of the field operations.

For descriptions of the experimental parameters, an analysis of the signal and background levels, a description of the calibration procedures, and a description of the preliminary laboratory investigations required to arrive at the laser design parameters, the reader is referred to the Semi-Annual Technical Report (Reference 1).

II. INSTRUMENTATION

The design of the breadboard is represented on the functional block diagram shown in Fig. 1. The laser transmitter components are located on the left of the diagram, the receiver components on the right. The signal processing, control, and recording electronics are along the bottom.

A. Laser Transmitter

The laser system consists of a nitrogen laser (#1) which generates a short light pulse of several nanoseconds duration at 3371 \AA , followed by an oscillator dye laser which converts the light to laser radiation at 4934 \AA . A diffraction grating in a Littrow configuration is used in the oscillator to tune the laser to a bandwidth of about 4 \AA . Further narrowing, which is necessary for the experiment, is produced by a Fabry-Perot interferometer. The interferometer consists of two Fabry-Perot etalons, one for coarse wavelength control, the other for fine. The spacing of the coarse etalon is fixed by a thin Cervit spacer having a very low coefficient of thermal expansion. The spacing of the fine etalon is controlled by a piezoelectric translator whose voltage is manually controlled to maintain the etalon spacing constant to a fraction of a wavelength of light. A barium lamp is used as a wavelength standard and the etalon is referenced to the standard by comparing the Fabry-Perot displays from the two units. In the comparison process both the main and hyperfine lines from the barium lamp could be observed in the comparison Fabry-Perot simultaneously with the laser line. The manual control was then used to adjust the voltage to

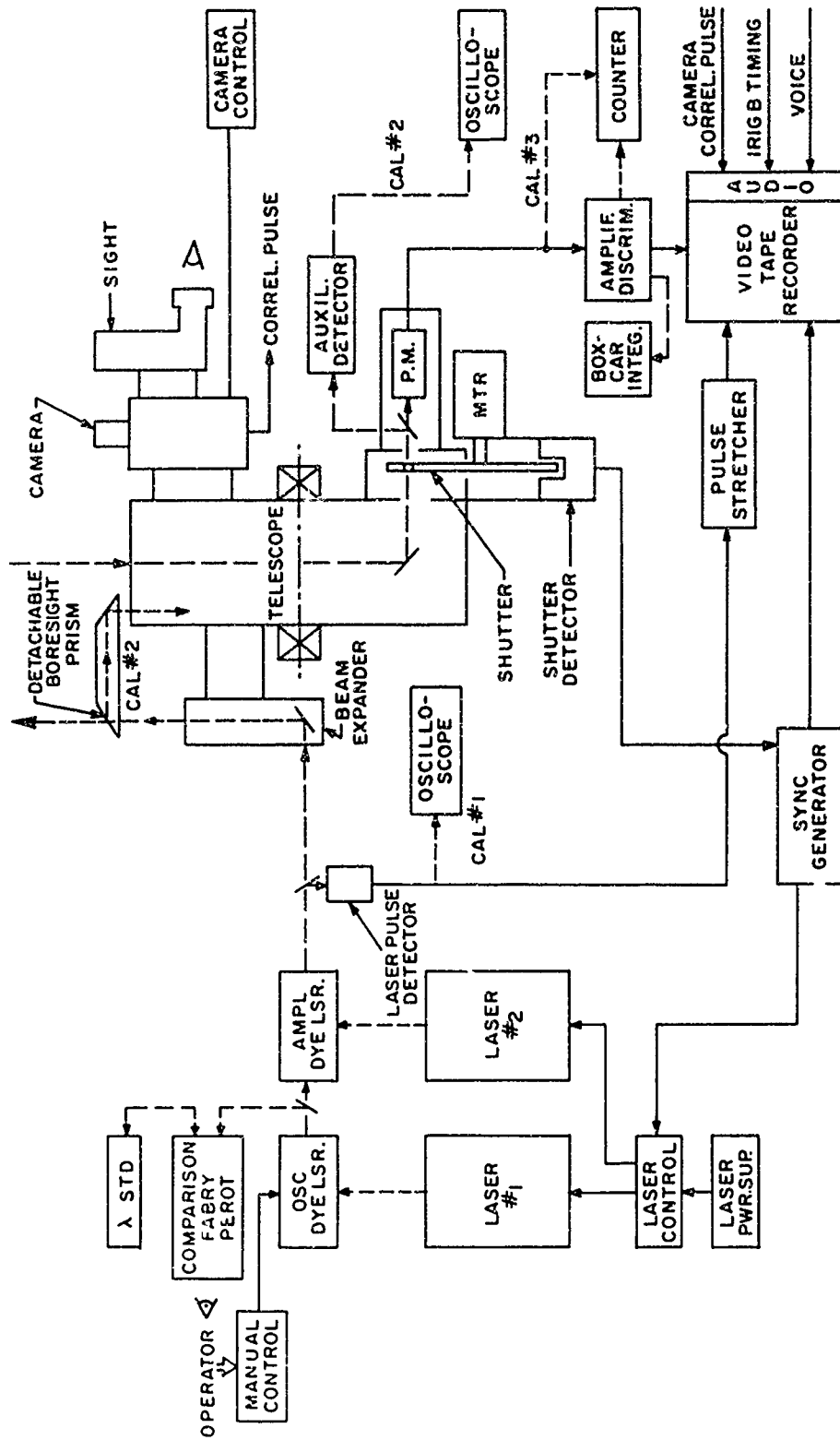

C5407

Fig. 1 Functional Block Diagram for Secede Laser Radar

the piezoelectric translator on the fine etalon to align the laser line with one or the other of the Barium lines.

The output of the oscillator dye laser is amplified in the next stage by an amplifier dye laser. The pump for the amplifier is a second nitrogen laser.

The laser beam is transmitted to the target by a collimator, or beam expander. The beam expander reduces the divergence of the beam to approximately .1 milliradian resulting in an illuminated spot which is 20m in diameter at the cloud. Between the amplifier and collimator was an adjustable quartz flat which could be tilted in two directions to provide beam steering.

B. Pointing System

The system for pointing the laser beam and receiving optics is shown pictorially in Fig. 2.* The transmitting optics, or beam expander, and the receiving optics, or telescope, are mutually aligned and mounted in a gimbal which rotates in elevation. A mirror is attached at 45° to the elevation axis to continually direct the laser beam in a direction parallel to the axis of the telescope. Also mounted and aligned to the telescope is a sight for aiming the laser at the desired portion of the cloud, and a bore-sight camera for recording the pointing position of the system. The entire elevation pointing mechanism and laser system are mounted on a platform which rotates in azimuth. The operator manually points the assembly by means of elevation and azimuth hand cranks while viewing the target through the sight.

* A photograph of the apparatus assembled for check out in the laboratory is shown in Fig. 2a.

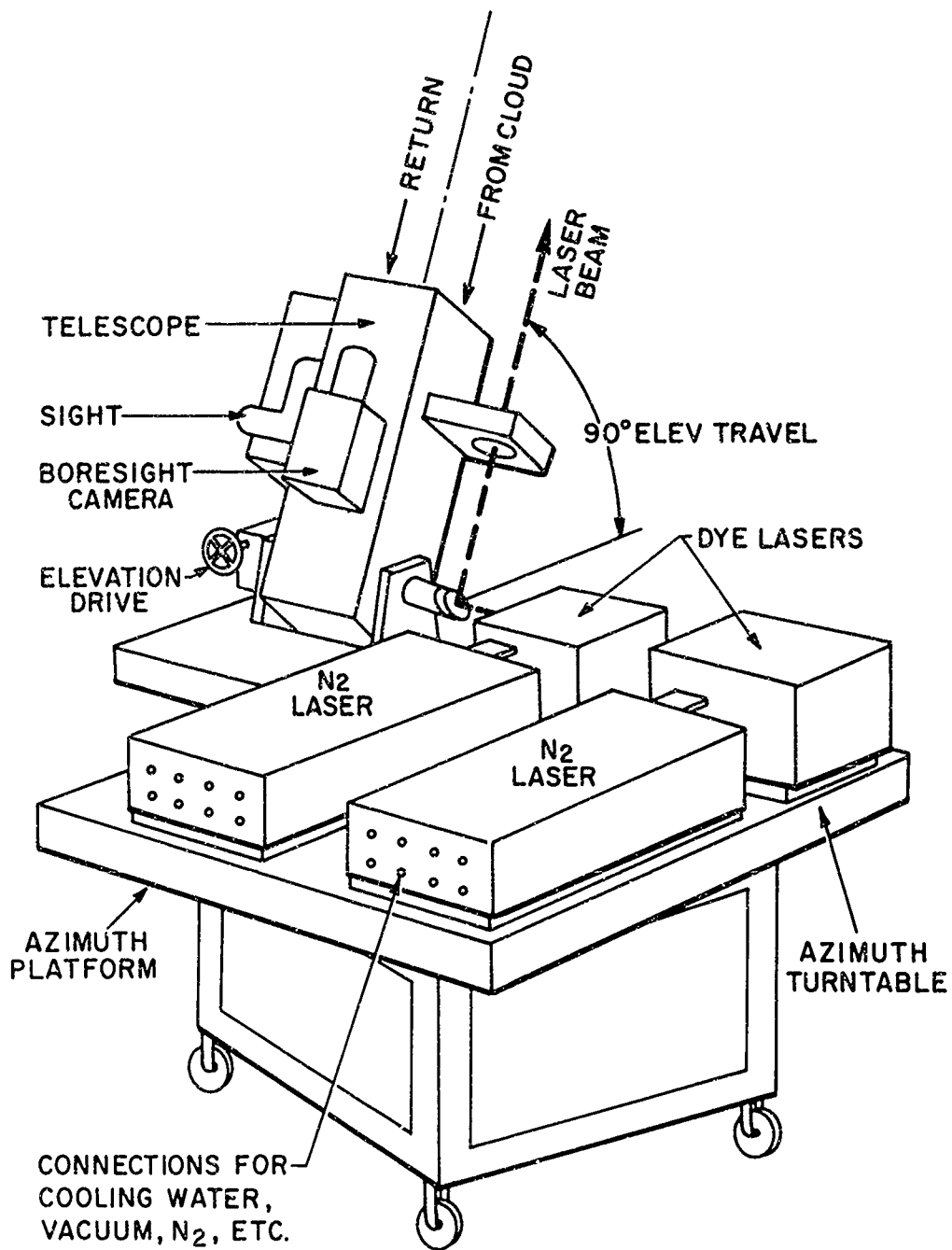
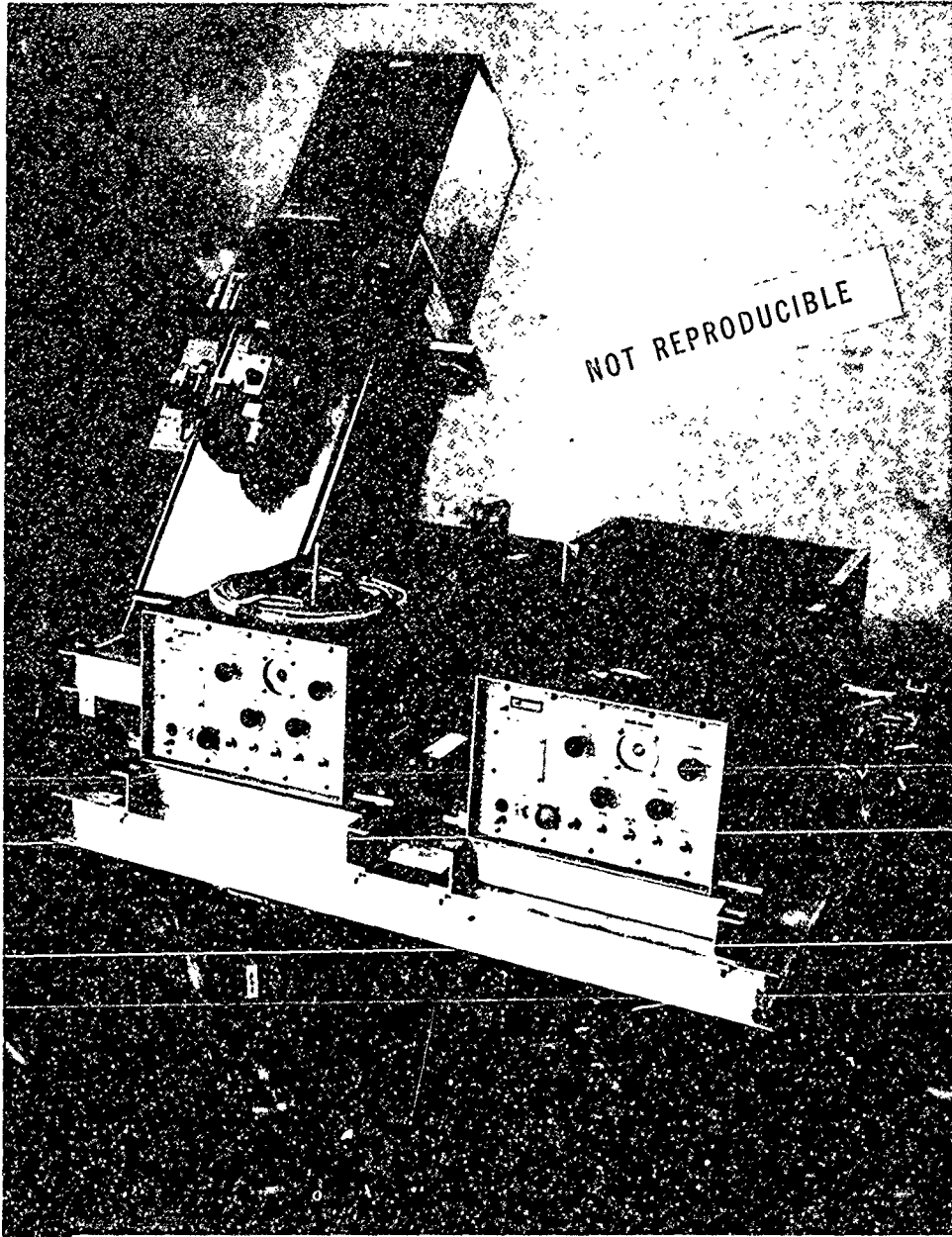

Fig 2 Pictorial View of Pointing System for Transmitter and Receiver



C8025

Fig. 2a Photograph of Pointing System for Transmitter
and Receiver

C. Receiver

A photometer is used to measure the return from the barium cloud. The receiving optics consist of a 16" diameter Newtonian telescope of $f/3$ relative aperture with a field stop and shutter located at the focus. Behind the field stop is a collimating lens, a narrow band filter, and the photomultiplier tube located in a cooled housing.

The most important factor in the design of the receiver instrumentation is that the expected return is much less than one photo-electron event at the PM per resolution element. The section which deals with signal and background, discusses several other factors which must be considered. For example, the photomultiplier will see an average background quite close to the permissible limit when one is photon counting. This requires shuttering of the receiving system so that the reflections of the laser light from low lying clouds or Rayleigh scattering in the near field of the receiver will not temporarily light strike the photomultiplier tube. The shutter consists of a rotating blade near the field stop of the telescope. The blade opens 120 times per second, once for each laser pulse. The opening of the shutter is synchronized with each laser pulse to reject return signals from objects closer than 50 miles and beyond 500 miles. The synchronization of the shutter with the laser is accomplished by a diode which detects the position of the shutter blade and initiates the laser trigger pulse.

In order to maintain an acceptably low background, the field of view of the telescope is kept small. It is just large enough to encompass the laser illuminated portion of the cloud and to allow for alignment tolerances between the laser and telescope. The field stop is adjustable both in size and location.

Before reaching the photomultiplier, the light from the image is collimated and filtered to keep extraneous background levels low. A 3" focal length lens is used to collimate the light and produce a 1" diameter spot on the face of the PM tube. The interference filter has a 5\AA bandwidth centered at 4934\AA .

The photomultiplier tube is an RCA 8850 located in a shielded housing capable of being cooled with dry ice. The tube is operated at a gain adequate to drive a single channel discriminator/amplifier which provides amplification and is operated so as to optimize the detection of single photo-electron events at the cathode surface, and subsequently discriminate against electrons arriving at the anode which are not due to photo-electron events originating at the cathode, and multiple simultaneous photo-electron events at the cathode.

In order to record the output on the Video Tape Recorder, the discriminator output pulses are stretched to approximately 500 nanoseconds so that they are compatible with the bandwidth limitations of the tape recorder. With a pulse width of 500 nanoseconds, we must also accept a dead period of the same time increment. However, since 500 n sec is much less than the mean time between arrivals at the photomultiplier, very little signal is lost due to pulse stretching.

D. Boresight Camera and Sight

The boresight camera and sight are attached to the telescope and aligned with its pointing axis. The sight is a military Elbow Telescope #M16A1C with a magnification of 3x and a field of view of 12° which is large enough to encompass the entire cloud.

The boresight camera is a Flight Research Model 207, which is a pulse operated double frame 35 mm camera. With a 4" focal length lens, the field of view is 14° wide x 20° high. The camera is pulse operated in the open to open mode so that long time exposures ranging from 2 to 120 seconds can be produced by framing the camera at the desired interval. If the camera is pulsed at intervals of 10 seconds per frame, it will provide over two hours of running time with a 100' film supply.

E. Control, Display and Recording Equipment

With reference to Fig. 1 (block diagram) the system timing is established at the receiver. The shutter (a rotating-wheel) is driven at the line frequency of 60 hertz by a synchronous motor.

Precision slits on the wheel are detected and generate a 120 pps time base. This time base is the only timing control signal in the system and is fed to the Sync Generator where it is fanned-out to the transmitter and recording instrumentation. In order to monitor system performance without recording on a video tape, a counter (Hewlett-Packard model #5201L) is provided to accumulate photomultiplier-discriminator output pulses. An on-site capability then exists to periodically test photomultiplier dark current, system noise, and laser output. Background measurements can also be made at various times using the Boxcar Integrator (Princeton Applied Research Model #160) for fairly high levels and the counter when lower level measurements are taken. This capability also allows a check on the receiver performance in the field compared to its performance in the laboratory. Both monitors have built in displays, variable integration/accumulator times and can be externally gated or synchronized as desired.

An oscilloscope is used to periodically check the laser monitor detector and the PM output pulse amplitude and shape.

The photomultiplier (RCA 8850) is operated from a Hewlett Packard Harrison (Model 6119A) high voltage power supply. The output of the PM is terminated at 50 ohms and is matched to the amplifier-discriminator. The discriminator has upper and lower threshold controls which are set at approximately the 5σ limit for the single photo-electron pulse height distribution. A pulse shaping (stretch) network is included as part of the discriminator. Its output is then fed to the Video Tape Recorder, Precision Instruments Model P13V.

The Video Tape Recorder has two channels, one for recording timing/audio information and the second for recording the main bang sync pulse and the discriminator output. These output pulses are generated every time the discriminator senses a single photon induced event or its photo-electric equivalent. Hence, the tape contains time resolved signal, background, and rarely, PM noise pulses. The timing/audio channel will record a serial IRIG-B real time of day on which is superimposed the operator's comments as required and an 8K Hz sinusoidal bursts from the audio oscillator (hp model 204B) which is triggered by the boresight camera frame correlation pulse. Direct real time correlation, therefore, can be accomplished on a per frame basis and the cloud range can also be determined when the tape is played back.

The operator has a microphone and momentary contact control switch which disconnects the timing signal while the voice signal is recorded. The majority of operator comments will be prior to and after the data gathering

interval. The information contained in the commentaries will be pre-mission system status, dark current and background measurement values, countdown et al.

III. SYSTEM ASSEMBLY, CALIBRATION, AND CHECKOUT

During the period from early November 1970 through 17 December 1970, the major subsystems of the laser radar were completed, assembled as a unit, and tested.

The laser radar system consists of four major subsystems -- optical, mechanical, receiver electronic and laser. During the assembly and checkout phase of this program, no significant changes were made to the mechanical and receiver electronic subsystems described in the preceding section. The optical subsystem was improved by the addition of secondary baffling and by the addition of a beam directing flat which, when used in conjunction with the transmitting telescope eyepiece, permitted alignment of the transmitted beam to within 0.0025" of the telescope trunion axis. This close alignment meant that there was no more than 0.005" lateral shift of the received beam in the receiver focal plane as the telescope was elevated over a 60° range. This lateral shift corresponds to an angular shift of 100 microradians.

The wavelength control servosystem of the laser subsystem did not function as designed. Apparently its electrical bandwidth was too narrow to accommodate the jitter in trigger rate when the shutter was used for system timing pulse generation. This servosystem had worked well when it was first tested in the laboratory using the commercial AC power lines as the source of timing pulses. It was decided to bypass the wavelength control servosystem because manual wavelength control proved to be adequate.

The wavelength comparator used to measure the laser output wavelength was improved to the point where the hyperfine line at 4934.04 \AA was visible to the naked eye. Average power measurements were made with an EG&G Model 580 radiometer system; however, a laser beam adapter was not available for use with this instrument. Therefore, accurate power density and relative power measurements could be made, but our absolute power measurements are only accurate to $\pm 30\%$. The maximum output of the laser was measured to be approximately 70 microjoules per pulse, corresponding to 8 milliwatts under the best conditions. However, the output at the wavelength of the desired hyperfine line was approximately 7 microjoules per pulse, corresponding to 0.8 milliwatts at 120 pps. During field operations, the power output varied with laser alignment, dye cell age, and temperature. Before Event SPRUCE, we measured this laser output power to be 2.4 milliwatts. The transmitted laser beam divergence was 230 microradians; during field operations we learned to improve this to approximately 180 microradians.

On 17 December 1970, the completed laser radar breadboard was shipped to its destination at Tyndall AFB, Panama City, Florida.

IV. FIELD REPAIRS, ALIGNMENT AND CALIBRATION

During the period 28 December 1970 through 15 January 1971, the laser radar breadboard was prepared for use in the experimental series. Unfortunately, the system suffered damage during shipment and while stored in its assigned building at Tyndall AFB. During shipment the alt-azimuth table slipped off its shock mountings; as a result, the dye laser amplifier dye cell was broken, also the ceramic seal of the energy storage capacitor of one of the C950 lasers was cracked. At the time the laser radar was delivered, 220 volt electric service had not yet been provided to the building assigned, nor had the gas space heater been installed; as a result the laser equipment was stored at ambient temperatures in a humid salty environment. Condensation damaged the videotape recorder and the receiver narrow band filter and severely attacked the mirrors employed in both the transmitting and receiving telescopes. These mirrors had been specially coated for maximum reflection at 4934 angstrom units; in retrospect, it would have been preferable to coat them for maximum durability in an unfriendly environment.

The shipping damage was identified immediately after arrival of the laser radar system at Tyndall AFB. A spare dye cell was completed and brought to the site with the experimenters on December 28. The period from 20 December 1970 to 15 January 1971 was employed in repairing the damage, in realigning the laser radar system and in making many minor configuration changes of the sort which are necessary to operate a complex prototype system in a field environment.

The videotape recorder which was our prime data recording instrument proved to be inoperable during field checkout. The supply motor was frozen and even after it was freed, the recorder was unable to maintain proper drive speed. It was replaced with a similar Precision Instruments videotape recorder rented from Continental Corporation.

The boresight camera lens was changed to index the effective field of view to about 20° high by 28° wide. A narrow band (100 \AA wide) filter centered at 4934 \AA was borrowed from the AFCRL personnel at the site and used for all events. During operations, this filter was removed after the sky background dropped sufficiently not to fog the film. This permitted the star background to be photographed and this provided absolute pointing information. The film used was Kodak 2475, specially processed for extremely wide dynamic range. The boresight photography was completely successful and has provided a large amount of information of the development of the barium clouds as well as serving its intended purpose.

Figure 2b is a photograph of the equipment in position at the field site. The original aluminum hood used in the laboratory proved too heavy and was replaced by a jury rigged cardboard and tape hood in the field. The larger electronics rack to the right contained the receiver electronics and was connected to the moving platform with an overhead umbilical. The building which housed the equipment at night is in the background.

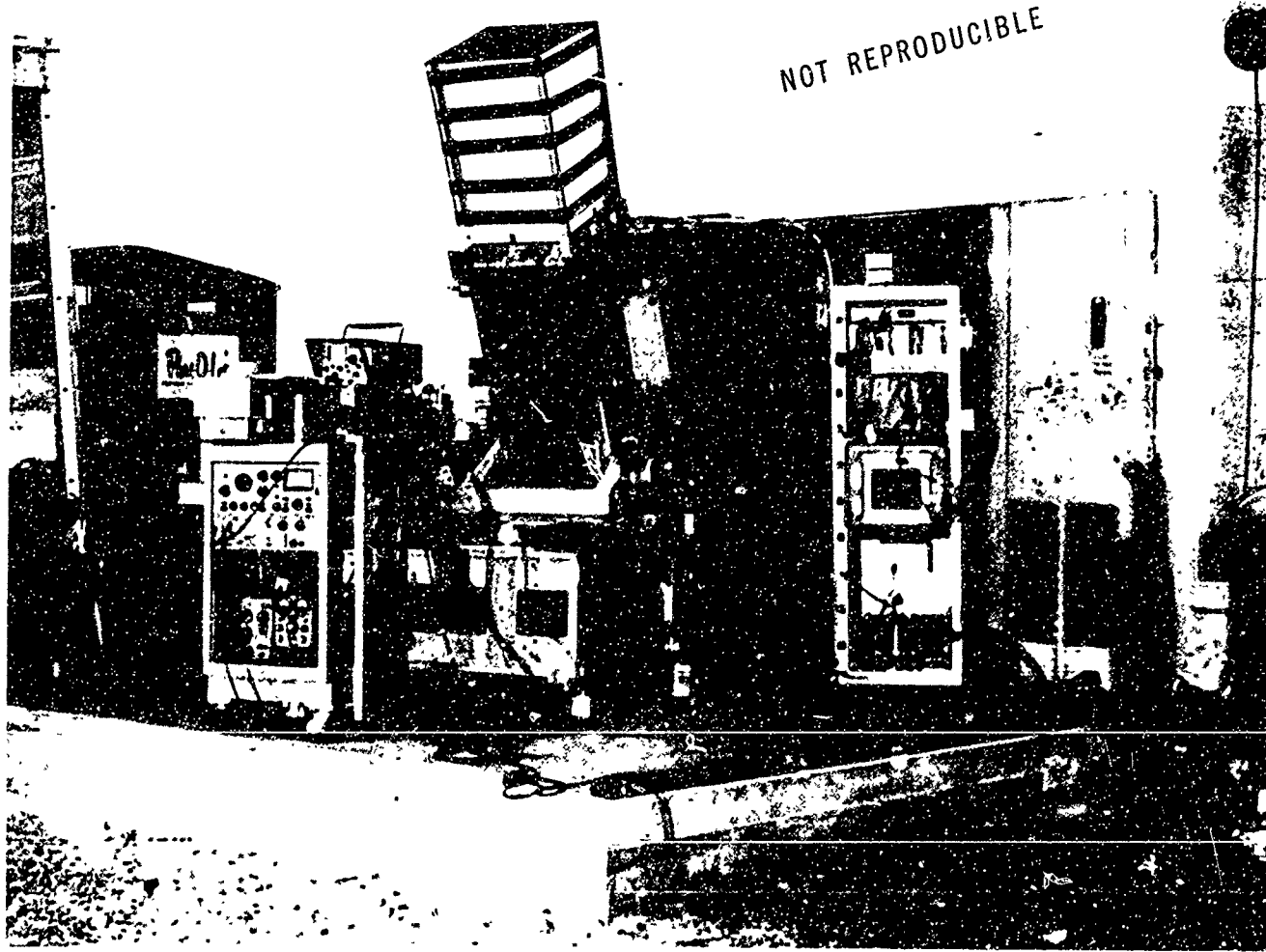

C8026

Fig. 2b Photograph of Equipment at the Field Site, Set-up
and Ready to Run

V. SECEDE II OPERATIONS

A. Event Nutmeg

Approximately 10 minutes after release, the laser power supply shut off, having sensed a fault condition. Although we reset the power supply and continued operating for some time thereafter, it is doubtful that significant data was gathered after the first 10 minutes, if at all. The problem was traced to the system timing circuitry. All system timing is based on the position of the shutter used to protect the receiver photomultiplier. This shutter has four narrow slits in it. On one side of the shutter there is a light emitting diode and on the other a phototransistor which senses light passing through a slit. The 12 volt, 10 microsecond output pulses from the phototransistor provide the basic 120 pps synchronization signals for the entire laser radar system. As the ambient temperature dropped below 40 degrees, the output power of the light emitting diode dropped to the point that insufficient synch signal voltage was present for system control functions. This problem was overcome by changing the diode biasing and adding small heater to the detector package.

The tape recorder data for Event Nutmeg has not been examined at this time.

B. Event Plum

It is of prime importance that the transmitting and receiving telescope be aligned to a small fraction of the transmitted laser beam width. This is so because the receiver field of view must be large enough to encompass the laser illuminated area of the ion cloud; therefore, angular

misalignment requires an unnecessarily large receiver field of view. The background to signal ratio increases as the square of the receiver field of view. We had constructed an alignment fixture which consists of two mirrors cemented to a quartz spacer in a configuration similar to that found in a dove prism. The optical portions of the alignment fixture were potted into a cylindrical holder which can be pinned to the side of the receiving telescope to divert a portion of the transmitted laser beam into the receiver. The transmitter and receiver can then be aligned and the receiver field adjusted so that the receiver field of view barely overlaps the transmitted beam at the barium cloud. This alignment fixture was used each time any adjustment was made to the laser system. The calibration fixture was itself calibrated in the laboratory against an external 96" focal length collimator. The collimator can itself only be used to align the laser system with the telescope in a horizontal position. The calibration fixture is then attached to the receiving telescope and aligned to duplicate the results of the 90" collimator. The telescope can then be elevated and the alignment of transmitter and receiver checked or adjusted at elevations other than horizontal.

Prior to Event Plum. the alignment fixture potting failed, thus permitting the optical elements to move and flex within the cylindrical housing. Fortunately, we had included the 96" master collimator in our backup equipment. Thus, we were able to calibrate the alignment fixture before each use. However, it was no longer feasible to carefully align the transmitted beam with the trunnion axis before each release. Therefore, prior to Event Plum and each succeeding event, we determined the field stop positions appropriate for a range of elevation angles and set the receiver

field stop for the expected elevation angle. As the telescope elevation was changed during an event, the field stop settings were also changed. In addition, as the resonantly scattered background radiation decreased with solar depression angle, we opened the field stops. Thus, approximately 30 minutes after release the receiver field stops were wide open, giving a receiver field view of approximately four milliradians. At this time the sun had set on the ion cloud and the resonant background was negligible.

During Event Plum it became obvious that the extremely rapid temperature drop experienced at sunset prevent us from maintaining wavelength stability.

We gathered approximately 1 hour and 15 minutes of data from Event Plum; the tape recorder data have not been examined.

C. Event Redwood

Prior to Event Redwood, the cause of the wavelength instability was traced to wavelength control etalon #1 (Ref. 1, pg 26). Modifications were made to the dye laser oscillator module to help maintain a constant temperature within the module. However, Event Redwood occurred before the modifications were complete. Here, too, we noted some wavelength instability during the rapid change of temperature following sunset.

The tape recorder data from Event Redwood has not been examined.

D. Event Olive

Prior to Event Olive, we completed our efforts to temperature stabilize the dye laser oscillator module. The etalon and grating adjusting micrometers were extended so that they could be adjusted without opening the module; the dye temperature was regulated by use of a thermostatically controlled fish tank heater, and a thermostatically controlled 25 watt light

bulb was installed inside the module to help maintain constant temperature. As a result of these modifications, it was possible to maintain a constant wavelength for long periods of time during Events Olive and Spruce.

A new photomultiplier filter had been ordered immediately upon our discovery that the original filter was damaged. The replacement filter (5.5 Å FWHH centered at 4934 Å) arrived in time to be used for Event Olive.

During the time interval from 3 to 12 minutes after release, the sky at our site was totally obscured by water clouds. However, we continued operating and obtained approximately 90 minutes of data.

We have made a preliminary analysis of 17-1/2 minutes of data covering the period from 39-1/2 to 57 minutes after release. Within the limitations imposed by the rather large range gate used for the preliminary analysis, there seems to be no statistically significant evidence for any laser radar return. These data are shown in Fig. 3.

Before we terminated operations for Event Olive, the laser power appeared to drop considerably. Later measurements indicated that this was indeed so.

E. Event Spruce

The laser output power was not increased by changing the laser dye, realigning the laser, etc. Diagnostic power measurements eventually revealed that the oscillator output power of 3×10^{-5} watts was greater than the amplifier output power of 1.3×10^{-5} watts. It should be emphasized that these measurements cannot be directly related to the output power during Event Olive, which were made with a different laser configuration. After removal of the amplifier dye laser cell from its module, the cause of the decrease in power became apparent. There was a brown photolytic

SECEDE LASER EXPT. EVENT OLIVE

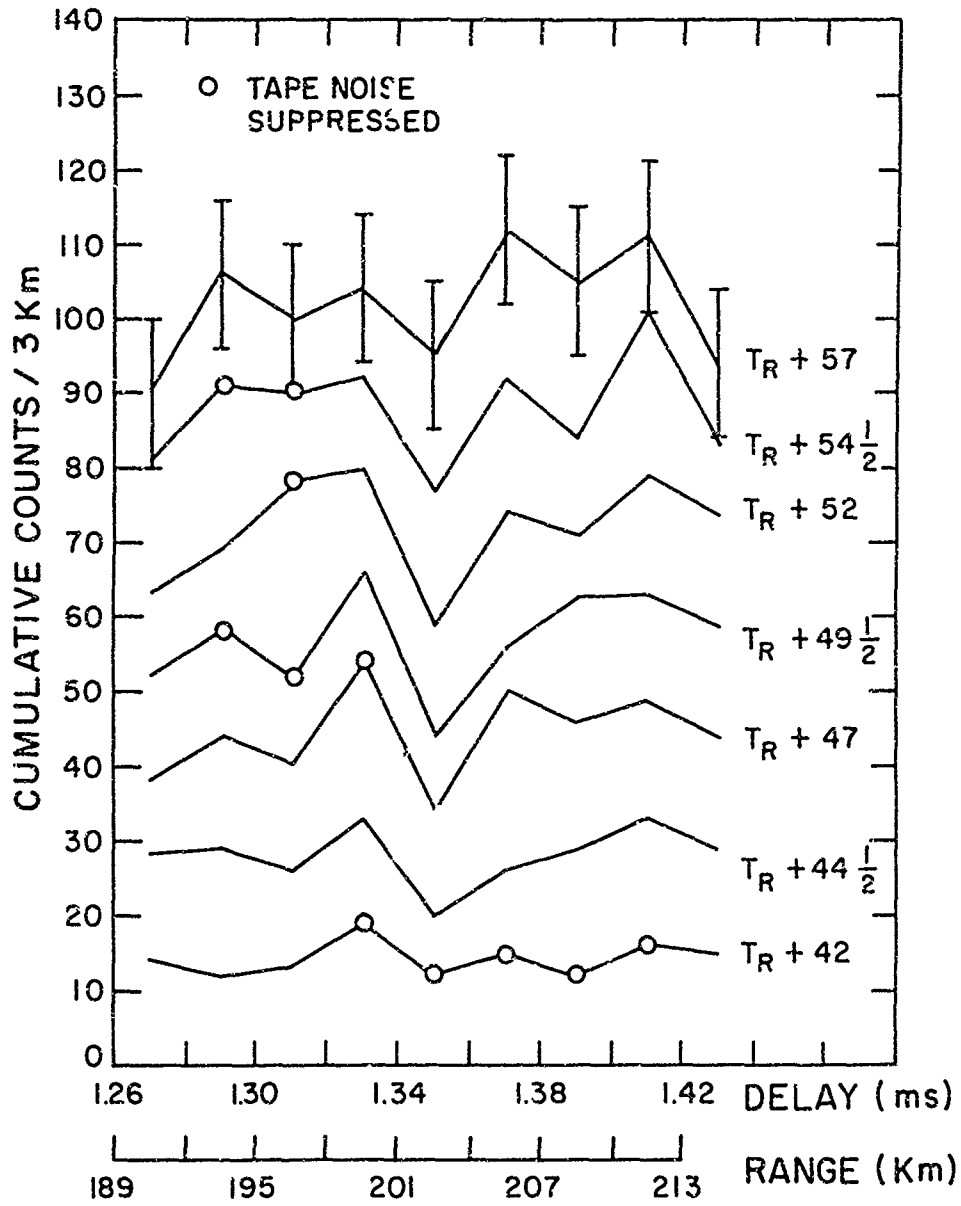

C6694

Fig. 3 Event Olive Preliminary Data Analysis

deposit on the interior of the quartz window of the dye cell where the focused ultraviolet pump light enters the dye cell. Apparently, during many hours of operation the ultraviolet pump light had broken down some constituent of the dye solution. We do not know whether or not the dye, the solvent or impurities were the cause of these deposits. However, in view of the fact that the oscillator dye cell showed no signs of deposit, despite having been used for many more hours than the amplifier dye cell, we believe that impurities present in the dye solution were the cause of the trouble. They may have been introduced either during the routine changing of dye solution for Event Olive, or, more likely, were introduced into the dye cell during its hurried assembly as a replacement for the dye cell damaged in shipment.

The original amplifier dye cell had been repaired and was installed in time for Event Spruce. With a clean amplifier cell, and with the experience gained during the preceding weeks, we were able to align the laser so that the measured output power at the beginning of Event Spruce was 2.4 milliwatts. The laser output was sufficiently strong, that atmospheric backscatter can be seen in the boresight camera records as a line in space extending from the foreground toward the aiming point on the ion cloud.

We gathered approximately seventy minutes of data during Event Spruce. cursory examination with 15 kilometer resolution of five minutes of data from 31 to 36 minutes after the release indicates that there may, indeed, be laser returns from the range gate between 180 and 195 kilometers. (See Fig. 4) This is approximately the expected range at that time for one azimuth and elevation angles. The excess of photons counted within that range gate over the mean number of photons counted in the 15 kilometer

SECEDE LASER EXPT. EVENT SPRUCE

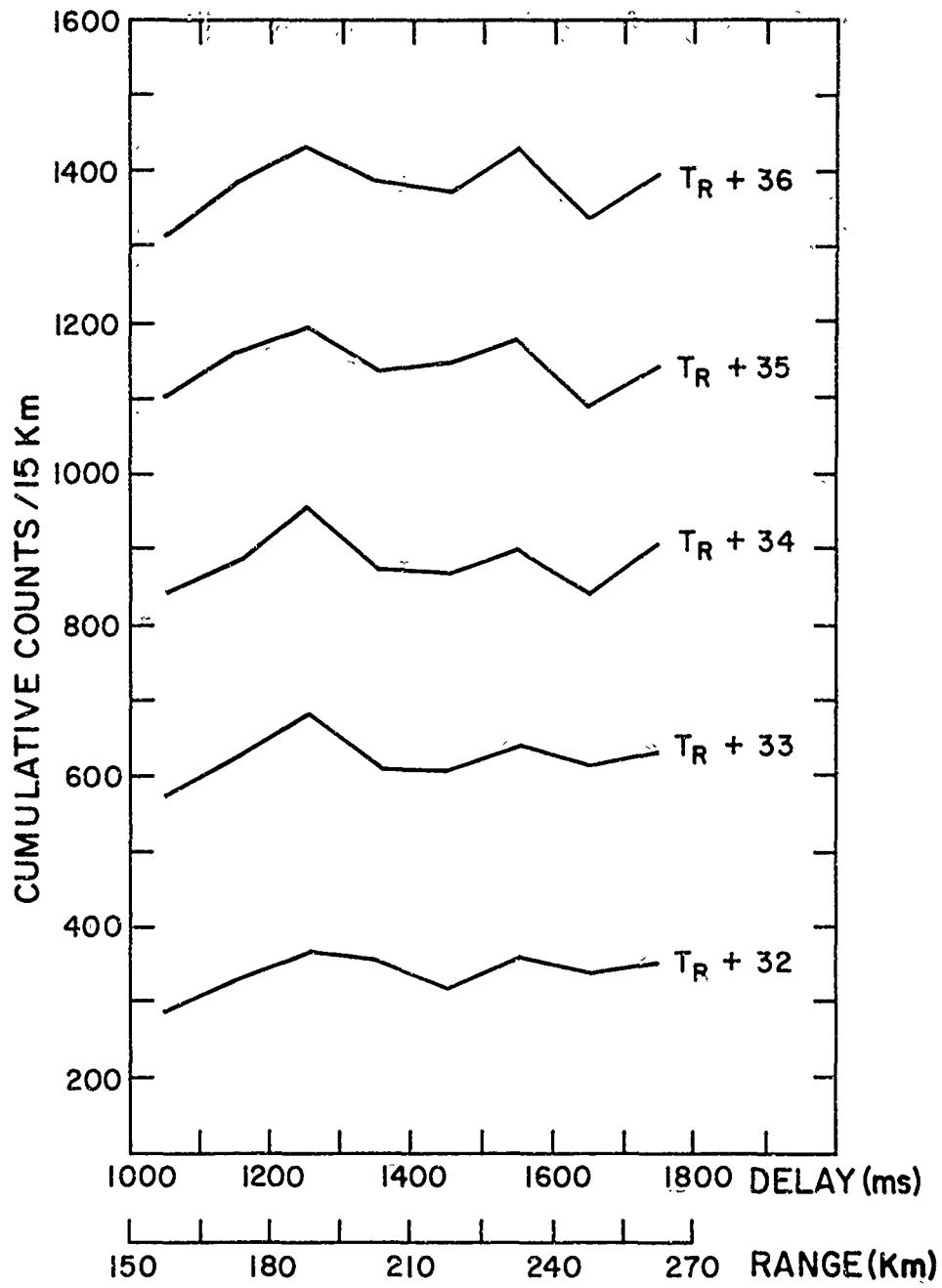

C7970

Fig. 4 Event Spruce Preliminary Data Analysis

range gates between 150 and 270 kilometers is less than one standard deviation. Therefore, we cannot ascribe any particular statistical significance to this evidence for laser return. By reducing the range resolution and increasing the integration time, the signal to noise ratio can be greatly improved; the data for 180-195 kilometers should be carefully examined.

Summary

During the month of field operation many minor modifications were made to the laser radar breadboard system. The result of these efforts was a system which was capable of operating in the field environment experienced. Initial difficulties experienced with operating at low ambient temperatures and during periods of rapid temperature change made reliable system operation extremely difficult. By the time we participated in Event Spruce, the environmental difficulties had been overcome and we are reasonably confident that laser radar return can be found on the video tape record for Event Spruce.

Perhaps the greatest impediment to rapid solution of the operational difficulties encountered, and in itself a formidable barrier to reliable operation, was the necessity for disassembling the laser radar system each time it was moved between storage building and the operational pad. Working on the system indoors was difficult and time consuming because of space limitations within the building. In retrospect, it would have been better to construct a building similar to that used by AFCRL at Site P3, a plywood shed with a demountable canvas roof. For further operations, serious consideration should be given to operating a wavelength-controlled laser radar system in a totally enclosed building equipped with a window to transmit the laser light.

We had originally hoped to determine whether or not we were sensing return pulses from the barium-ion cloud in real time. Both proved to be unfeasible. The rapidly varying background during the early portions of the experiment made it impossible to scan a single narrow range gate slowly through the return and compare the number of pulses counted in adjacent range gates. Data from different ranges have to be averaged over the same time interval. We also displayed the return on an oscilloscope with an A-scope presentation. However, because the background was great, we were unable visually to pick out any interval which contained signal.

The boresight camera pictures have proven useful in their own right, aside from their intended use of determining the pointing direction of the laser. They are of good quality, give a continuous record of the cloud development for all the releases, and show suitable star backgrounds. Some radiometric analysis of the photographs has been performed by the AERL theoretical group, and will be reported separately by them under other contracts.

VI. LABORATORY DATA ANALYSIS

A. Tape Recorders

After returning to the laboratory, considerable effort was expended to renovate the original video tape recorder so that working copies could be made of the experimental tapes. After these repairs, it was possible to make video quality tape recordings on either machine which could be played back on the other and displayed on a video monitor. Unfortunately, the requirements of instrumentation recording are far more severe than those imposed by television display. We were unable to maintain adequate signal synchronization when data tapes recorded on one machine were played on the other. Furthermore, dubbing proved unsuccessful because of the high noise levels in the tape recorder output. Rather than expending a great deal of time and money in solving these peripheral problems, we decided the least expensive alternative was to purchase the tape recorder used in the field and to analyze the master tapes.

The video tapes proved to be extremely noisy, and the noise level increased with use. It was found that oxide dust from the recording surface was the cause of this problem. Unlike computer or instrumentation tape, video tape is not designed to undergo washing or cleaning, and the manufacturer (AMPEX) strongly advised against using any of the standard tape cleaning techniques. Experiment showed us that we could reduce tape noise to acceptable levels, without damage to the data records, by carefully wiping the back of the tape during each rewind cycle. This procedure picked up most of the loose magnetic dust. Careful adjustment of the Hewlett-Packard

counter discriminator circuits eliminated most of the remaining noise pulses. (Total accumulated counts from the same five-minute tape record would vary by only two or three counts if a data scan was repeated.)

B. Target Range

Estimates of range to the cloud were available from a number of sources. The preliminary cloud track had been obtained from Neil Davis and the University of Alaska had kindly made real time calculations of estimated range from our site to the "cloud center." However, especially at late times after television tracking was terminated, it was hard to correlate the point at which we were pointing with the gross cloud center. Therefore, we calculated range to Event Olive from the pointing information in the star photographs, the taped timing information, and the photographic record of sunset on the cloud top. We believe we located the cloud with an uncertainty of 10 km.

C. Experimental Techniques

Two experimental techniques for scanning the data were devised. The first, a digital technique, is best suited for actual data analysis. When unautomated, it is noisy and time consuming. Since our primary concern was to devise a technique to reduce the data on the video tapes, this was our first effort. It is evident that the digital approach is not suited to scanning large quantities of data. In order to locate regions for closer scrutiny, we fabricated an analog raster display for scanning the data. This analog equipment has not yet been used.

Figure 5 shows the tape video data format as it appears on an oscilloscope display. The main bang synch pulse (MBSP) is the output of the laser pulse detector, a fast photodiode which picked off some of the dye

SECEDE LASER EXPERIMENT
VIDEO FORMAT

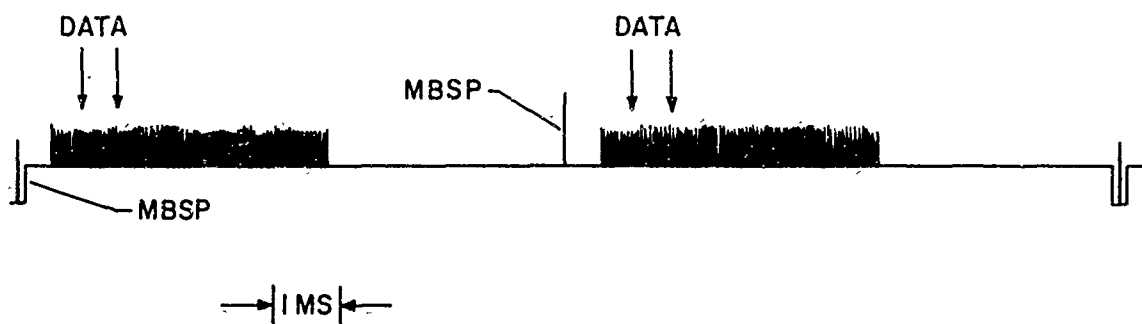

C6695

Fig. 5 Video Format

laser oscillator output. This signal is used as the basic timing reference for the signal return from each laser pulse. It occurs approximately 100 μ sec after the shutter trigger pulse. Its absolute time can be found by reference to the IRIG-B timing signal written on the audio channel. The video synch pulses occur at a 60 Hz repetition rate; the main bang synch pulses at the laser repetition rate of 120 Hz. That is why every other MBSP in Fig. 5 is shown sitting in the remnant of the VTR "synch notch." The data are buried in the background. The shutter was open, permitting light to reach the photomultiplier only from 0.6 to 4.8 milliseconds after the laser pulsed.

D. Digital Technique

Figure 6 is a logic diagram of our digital signal processing technique.

A Rhode and Schwartz Time Standard was used to continuously calibrate all timing equipment; as a result, a rather crude multi-stage technique was able to maintain timing relative to the MBSP to much better than 5 μ sec (less than 1 km range uncertainty).

The tape recorder synch output signal was used to trigger a Techtronix 453 oscilloscope and the MBSP displayed on a greatly time expanded delayed sweep. Thus, the MBSP was isolated from all other pulses; the delayed sweep gate output from this oscilloscope was used to trigger the Hewlett-Packard pulse generator which was part of the Secede receiver system. The pulse generator was used to generate a calibrated delay (with one millisecond delay corresponding to 150 km range delay). The pulse generator output was, in turn, used to trigger the Techtronix 547 monitor oscilloscope. The delayed sweep gate output of this oscilloscope was then

SECEDE LASER RADAR EXPT. SIGNAL PROCESSING

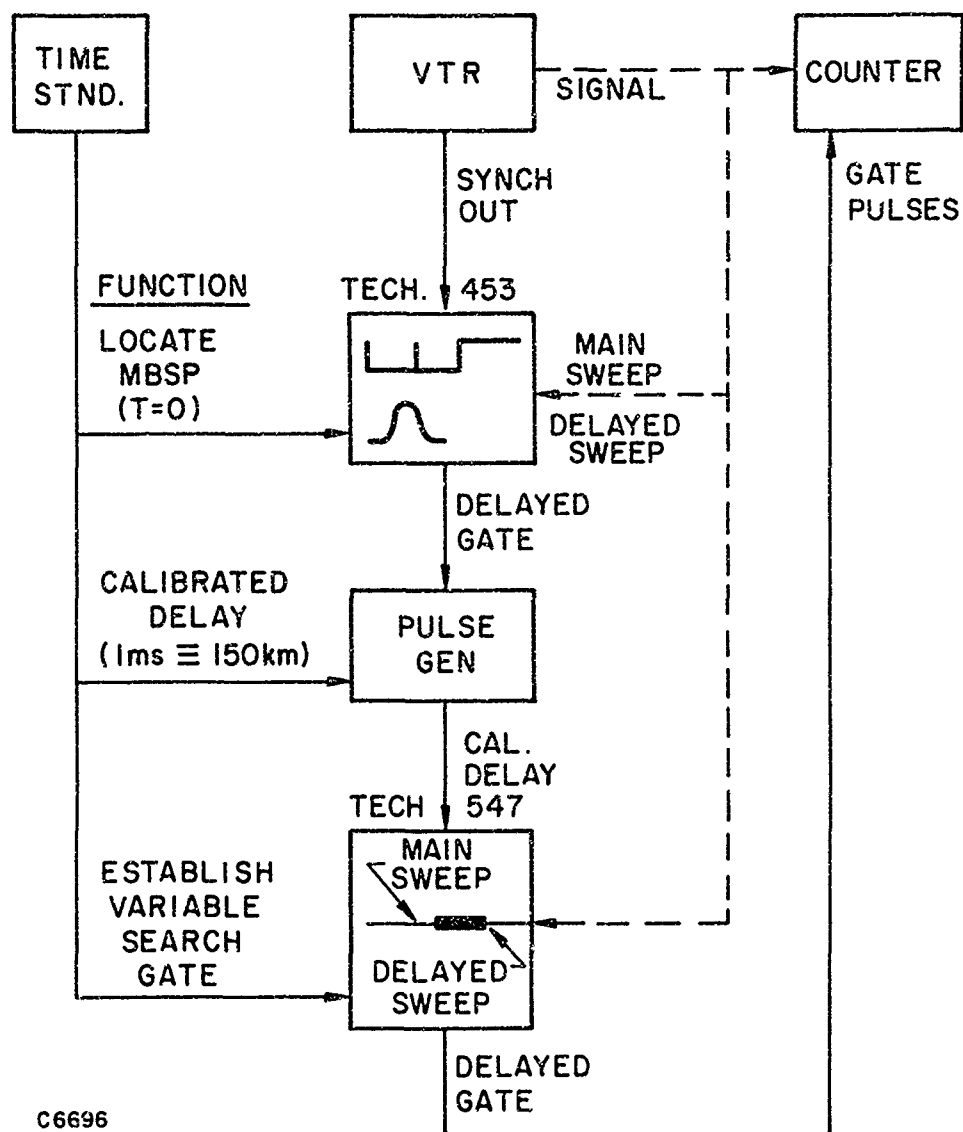

C6696

Fig. 6 Digital Signal Processing Logic Diagram

used to establish a variable range gate which gated the Hewlett-Packard counter for the appropriate time interval.

Because there are two laser pulses for each tape recorder synch pulse and because the 453 delayed sweep is set for a unique time delay, return photons from every other laser pulse are examined in one pass of the tape. Also, each range interval examined requires one tape pass. Searching for photons returned from the cloud takes less time when a large range gate is used, but, since the cloud is probably less than 1 km thick at the times and places we choose to examine, the signal to noise ratio increases linearly with the range gate.

A promising portion of the tape record for Event Olive was examined with 15 km resolution. There appeared to be convincing evidence of signal return at the expected range. Closer examination with 4 km resolution proved otherwise; the "signal" was shown to be tape noise. (It was at this point that we discovered our serious noise problem.) Figure 3 shows the total number of counts accumulated in each 3 km range bin between 189 and 213 km. After fifteen minutes of accumulating photon counts, no range bin shows more than one standard deviation greater number of photons than the average. Therefore, we conclude that there is probably no signal return in that portion of the tape record for Event Olive lying between 42 and 57 minutes after release.

After we had learned how to suppress tape noise, a four-minute section of the tape record for Event Spruce was examined with 15 km resolution. Although only a very short time interval was examined with poor resolution, the record, Fig. 4, shows two statistically interesting peaks. One, between 225 and 240 km, probably represents statistical noise; the

other, between 180 and 195 kM may be the result of statistical fluctuations, but equally probably, may represent signals return.

These two range intervals should be examined in more detail.

E. Analog Scanning Technique

After the poor signal to noise ratio, low resolution, and tedious nature of gross manual digital scanning became apparent, we designed and fabricated an analog raster scan method to perform this task. Using the available equipment, it will be possible to rapidly scan large amounts of data with less than 1 kM resolution. Two passes will suffice to completely cover any section of tape; after a return signal is located, the digital method can then be used to analyze the return profile.

An electro-mechanical ramp generator was fabricated which provides an accurately controlled voltage. This voltage is applied to the vertical deflection plates of the Techtronix 547 oscilloscope. The photographic resolution attainable limits us to a five minute ramp. Meanwhile, as described already, the VTR output synch pulse is used to trigger the 453 oscilloscope; the delayed sweep gate output of this instrument triggers the pulse generator which, in turn, triggers the main sweep of the 547 oscilloscope. The 547 sweep intensity is set so low that no sweep appears on the oscilloscope screen. Even a five minute time exposure with a recording oscilloscope camera leaves the film black.

Meanwhile, the VTR signal output is sent to the counter, as described before. In order to aid in suppressing tape noise, the counter discriminator circuitry is used. The discriminator output is tapped and used to drive a buffered one-shot multivibrator. The multivibrator output is amplified and applied to the unblanking circuitry of the 547 oscilloscope. Thus, every photon counted causes a spot of light to appear on the oscilloscope face.

If return signal is sensed from several laser pulses, the spots will appear as a connected line on our photograph of the oscilloscope face. Noise pulses should appear randomly distributed over the screen.

Every five minutes it will be necessary to stop the tape recorder, close the camera shutter, advance the film, and reset the ramp generator. The scanning can then be resumed.

VII. CONCLUSIONS AND RECOMMENDATIONS

We built and fielded a breadboard model of a laser radar experiment to probe the Barium clouds released during Secede II. It required most of the test series to shake down and make field modifications to the experiment. By the final test, Event Spruce, the equipment appeared to be working properly, and we expect that there is significant data on the tapes from Event Spruce. Preliminary data analysis of the Spruce tapes yields ambiguous results.

It is recommended that better data analysis equipment be set up to scan the tapes from Events Olive and Spruce for significant data.

It is suggested that breadboard models are not compatible with field experiments. A breadboard model is the simplest possible form; a field experiment requires redundancy to ensure success, and hardening against harsh and variable environmental conditions.

It is believed that laser radar probing of ion clouds is a significant and useful technique which will yield much useful data in the near future. We were almost there, this time.

ACKNOWLEDGMENT

To the many people in this laboratory who contributed so greatly, and with much extra effort, in order to enable us to get into the field on time, our sincerest thanks. These included P. Bourgeois, E. Chaves, F. Cunningham, M. Freuchet, P. Griffiths, P. Murray, F. Pettis, R. Rennie, J. Saulnier and R. Serris.

REFERENCE

1. Secede Laser Radar Experiment Semi-Annual Technical Report, Contract F30602-71-C-0025, I. Itzkan, P. G DeBaryshe and R. A. Kirk, November 1970.