

RAMS 1st Quarterly Technical Report

INTRODUCTION

Since this is the first Quarterly Report, some of the background that led to the identification of a need for RAMS will be described. Researchers have been going to the Arctic for many years to collect data of various types. In almost all cases, experiments involving manned camps on the ice have resulted in frustration, danger, high cost and seasonal and geographical limitations. The only successful bases for year-round operation have been the manned ice islands such as T3. The number of these islands is limited and the logistics cost of maintaining them is extreme. The technical quality of people that will spend long periods in the Arctic is not always consistent with accurate data collection.

An obvious, yet almost completely neglected solution⁽¹⁾ is remote radio telemetry stations with data collected by shore, aircraft, ice island or satellite receivers. The Russians have recognized this need and have developed the Drifting Automatic Radio Meteorological Stations (DARMS)⁽²⁾. These stations have been in use since the early 50s and have been moderately successful.

The Coast Guard and now NOAA have recognized the need in the open ocean for similar stations and have established the National Data Buoy Project to develop and implant an extensive system of telemetry buoys for the purpose of collecting oceanographic and meteorological data.

RAMS differs from the above programs in that it provides long term data storage in the form of a digital memory. The digital memory will be modular and therefore can be expanded or contracted to meet the needs of a wide

variety of sensors. Because of the long term data storage, it does not depend on consistent daily transmissions to prevent data loss.

TECHNICAL SUMMARY

A High Frequency (HF) telemetry link was chosen as being the only method having adequate coverage of the 200-1000 nautical mile range with reasonable power levels and relatively unsophisticated equipment. A propagation study showed that a frequency between 6 and 7 MHz would provide reasonable reliability for all ranges and all seasons of the year. If the station was expected to remain at ranges between 200 to 400 miles, a frequency between 4 and 5 MHz would be more optimum. If the station was expected to remain between 800 to 1000 miles, a frequency between 8 and 9 MHz would improve the reliability. A block diagram of the RAMS station is shown in Figure 1.

The transmitter design includes a broad band power amplifier and a frequency synthesizer which will allow easy selection of these bands. Frequency shift keying (FSK) single side band (SSB) modulation will be used to minimize bandwidth and provide effective data transmission.

Several antennas are presently being evaluated for the program in local testing. These are a turnstile, a 1/4-wave ground plane and a directional discontinuity ring radiator (DDRR). All of the antennas have an omnidirectional pattern. The DDRR is preferred at the present time because of its small (relative to the others) horizontal profile.

Two power supplies are being considered. One uses a propane fuel thermoelectric generator which provides a continuous 8 watts of power. The other is a gasoline engine driven alternator which has been converted to propane which provides up to 3 kilowatts of power for short periods of time. The alternator is more efficient than the TE cell in converting propane to electricity. However, the inefficiency of the TE cell is in the form of heat which can be

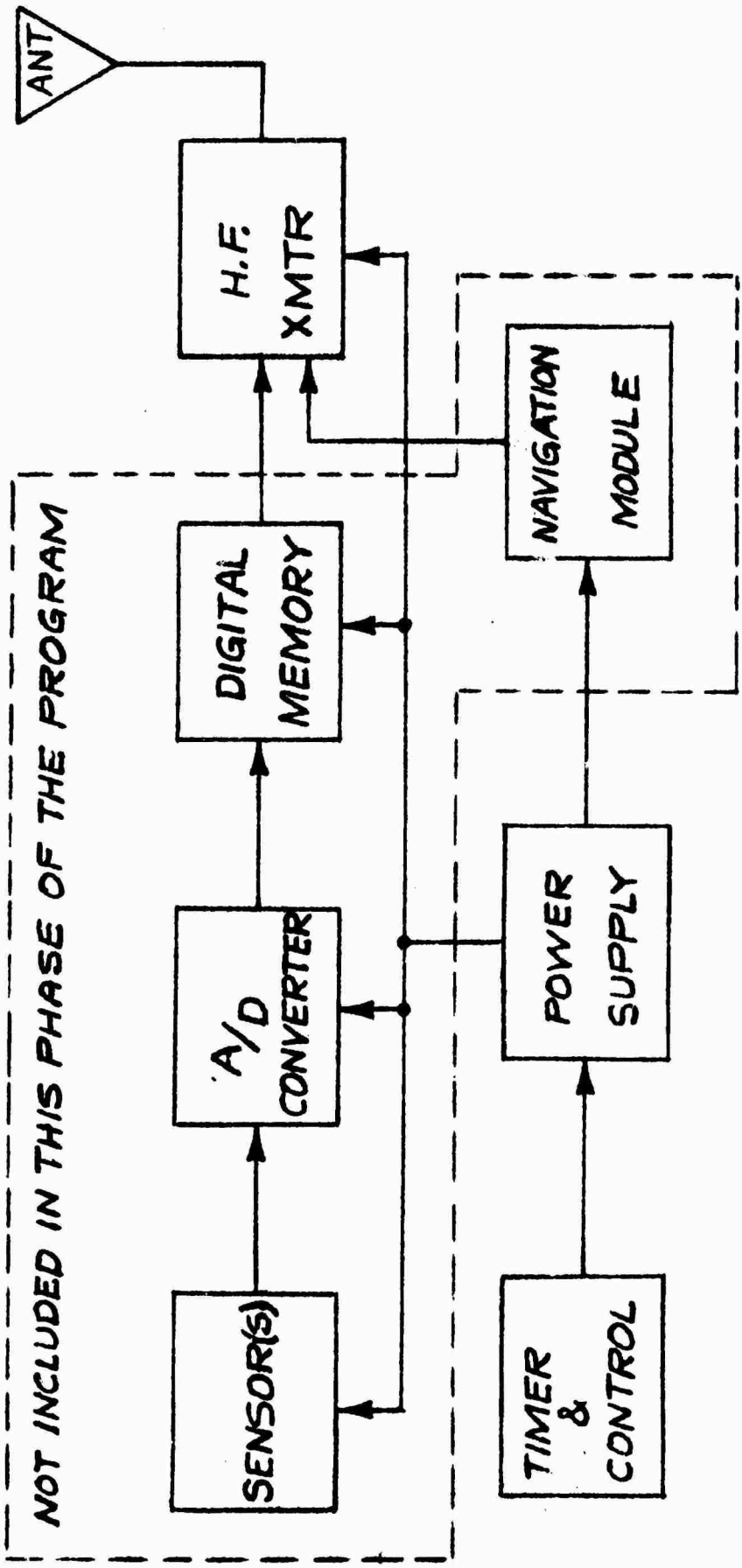

BLOCK DIAGRAM OF RAMS STATION

FIG. 1

used to keep the equipment at a reasonable temperature. Both supplies are planned to be tested in the upcoming field test.

For the field test, the timer and control will be an Accutron watch. However for the final design, a digital countdown from the master oscillator will be used.

The sensor, A/D converter, memory and navigation module are not part of this phase of work and will not be discussed here.

The experimental RAMS station is presently being fabricated and field testing is tentatively being planned for late November or early December.

TECHNICAL APPROACH

Frequency Selection

Because of the limited deployment seasons, available shore monitoring sites, ice movement and costs, a target range of 1000 n mi and a life of one year was decided on for the development. This set constraints on power supplies and available propagation modes for the radio telemetry. DARMS uses a ground wave propagation at medium frequency and attains a mean range of 300 n mi. Since that system has been used mainly to monitor conditions along the Northern Sea Route, these ranges to shore receivers have been satisfactory for their purposes. However, MF would not meet the RAMS target range of 1000 miles. Lower frequencies were ruled out because of antenna sizes and power. (To attain maximum life, the horizontal profile of the station must be minimized to reduce the probability of ice movement damage. Also because of wind-induced guy wire vibration noise which is highly objectionable for certain underwater acoustic measurements sensors - guys must be minimized, decoupled or eliminated entirely.) Troposcatter at VHF was ruled out because of power considerations. A relay system was deemed impractical

because of ice movement. Satellite retransmittal has the disadvantage of high platform costs, low data capacity and the unknowns of long-term satellite availability. Also, no satellite is available for possible uses of the system for military applications should these be desired. Meteor burst communications at VHF might be feasible but was temporarily shelved for consideration in favor of HF skip propagation techniques which are better known and better fit the development schedule and available funds. Also, antenna sizes were reasonable and long-term Arctic experience was available (NARL - ice stations communications at 6.5 MHz) for the latter. It was realized that long range HF propagation suffered periods of complete outage during polar cap absorptions that can last for up to several days. This disadvantage is a serious one for applications requiring real time uninterrupted data periods. However, the RAMS concept, which uses long term data storage, can stand communication link outages of up to several weeks depending on the number of sensors.

HF Link Analysis

The basic parameters of the HF link were verified by using an HF propagation prediction service available from the Institute for Telecommunications Sciences of the ESSA Research Laboratory. The program provides a variety of output data, Figures 2 and 3, which is dependent on the input parameters that can be provided. The important information available in this program is the reliability of the link as a function of frequency and universal time (Zulu time). To provide this output, a number of link parameters had to be assumed. Early in the program a power level of 100 watts PEP was selected as being compatible with solid state hardware state-of-the-art and with available power constraints. A vertical antenna was chosen for the transmitter since an omnidirectional pattern was required because of possible ice pack rotation. A simple 1/2-wave horizontal dipole was chosen for the receiving

MARCH 15, 1972 10 CM FLUX 101 (SSN 49)

BUOY TO BARROW, ALASKA AZINUTHS MILES KM.
 65.13N - 113.84W 71.27N - 156.83W 310.22 90,00 1151.5 1853.1

MINIMUM ANGLE 0.0 DEGREES

XMTR 2.0 TO 30.0 VERTICAL H -0.00 L -0.25 A -0.0 OFF AZ 0.0
 RCVR 2.0 TO 30.0 HORIZ HW DIPOLEH 10.00 L -0.50 A -0.0 OFF AZ 0.0
 POWER= 0.10KW 3 MHZ NOISE=-165.6DBW TIME= 50 PERCENT REQ.S/N=47.00B

FREQUENCIES IN MHZ

UT	MUF	3.0	4.0	5.0	6.0	7.0	8.0	9.0	10.0	11.0	12.0	14.0		
02	13.8	K(0)MUF=(17.1)				K(5)MUF=(11.8)								
	1F	3F	2F	2F	2F	1F	1F	1F	1F	1F	1F	1F	MODE	
	15.9	39.0	27.4	27.0	27.2	12.0	11.9	11.8	11.9	12.2	12.7	15.9	ANGLE	
	6.8	8.3	7.2	7.2	7.2	6.5	6.5	6.5	6.6	6.6	6.6	6.8	DELAY	
	345	246	247	251	259	251	253	257	263	271	282	345	VIRT HT	
	.50	.99	.99	.99	.99	.99	.99	.99	.99	.93	.81	.47	F. DAYS	
	128	133	130	129	129	128	128	129	129	129	129	128	LOSS DB	
	17	1	9	10	12	15	16	16	17	17	17	17	DBU	
	-108	-113	-110	-109	-109	-108	-108	-109	-109	-109	-109	-108	SIG.DBW	
	-173	-166	-170	-173	-170	-171	-172	-171	-171	-171	-171	-173	NOI.DBW	
	64	53	60	64	61	62	64	62	62	62	62	65	S/N DB	
	.83	.64	.78	.83	.81	.82	.82	.80	.80	.80	.80	.84	F. S/N	
	.42	.64	.77	.82	.81	.82	.82	.80	.80	.75	.65	.39	REL.	
04	12.5	K(0)MUF=(15.8)				K(5)MUF=(10.3)								
	1F	2F	2F	2F	1F	1F	1F	1F	1F	1F	1F	1S	MODE	
	15.9	27.8	27.3	27.5	11.9	11.8	11.9	12.1	12.5	13.0	14.1	2.5	ANGLE	
	6.8	7.3	7.2	7.3	6.5	6.5	6.6	6.6	6.6	6.6	6.7	6.3	DELAY	
	347	254	258	264	257	261	265	271	279	291	311	110	VIRT HT	
	.60	.99	.99	.99	.99	.99	.96	.89	.80	.72	.64	.50	F. DAYS	
	130	124	125	126	127	128	129	129	130	130	131	130	LOSS DB	
	16	12	13	13	15	16	16	16	16	16	16	15	DBU	
	-110	-107	-105	-106	-107	-108	-109	-109	-110	-110	-111	-110	SIG.DBW	
	-170	-166	-168	-167	-168	-168	-168	-168	-168	-168	-169	-173	NOI.DBW	
	60	62	63	61	61	60	59	58	58	58	59	62	S/N DB	
	.74	.76	.78	.77	.75	.74	.73	.72	.71	.71	.73	.78	F. S/N	
	.45	.76	.77	.77	.74	.73	.70	.64	.57	.51	.47	.39	REL.	
06	9.2	K(0)MUF=(9.2)				K(5)MUF=(9.2)								
	2S	2F	1F	1F	1F	1F	2S	2S	1S	1S	1S	1S	MODE	
	11.2	28.6	12.7	12.6	12.7	13.1	11.2	11.2	2.5	2.5	2.5	2.5	ANGLE	
	6.4	7.3	6.6	6.6	6.6	6.6	6.4	6.4	6.3	6.3	6.3	6.3	DELAY	
	110	276	273	278	283	292	110	110	110	110	110	110	VIRT HT	
	.88	.99	.99	.99	.99	.99	.96	.89	.83	.76	.69	.56	F. DAYS	
	129	123	124	126	127	128	129	129	130	130	130	130	LOSS DB	
	16	13	16	16	16	16	16	16	15	15	15	15	DBU	
	-109	-103	-104	-106	-107	-108	-109	-109	-110	-110	-110	-110	SIG.DBW	
	-167	-162	-163	-163	-164	-165	-166	-167	-168	-170	-172	-174	NOI.DBW	
	58	60	58	58	58	57	57	57	59	60	62	64	S/N DB	
	.71	.73	.71	.71	.71	.70	.70	.71	.73	.75	.77	.80	F. S/N	
	.63	.73	.71	.70	.70	.70	.67	.63	.60	.57	.53	.45	REL.	

Figure 2. HF Propagation Prediction Program Output

57

MARCH 15, 1972 10 CM FLUX 101 (SSN 49)
 BUOY TO BARROW, ALASKA AZIMUTHS MILES KM.
 68.85N - 128.06W 71.27N - 156.83W 297.13 90.01 691.0 1112.0
 MINIMUM ANGLE 0.0 DEGREES
 XMTR 2.0 TO 30.0 VERTICAL H -0.00 L -0.25 A -0.0 OFF AZ 0.0
 RCVR 2.0 TO 30.0 HORIZ HW DIPOLEH 10.00 L -0.50 A -0.0 OFF AZ 0.0
 POWER= 0.10KW 3 MHZ NOISE=-165.609W TIME= 50 PERCENT REQ.S/N=47.00B
 MUF(****) - FOT(++++) - LUF(.....)

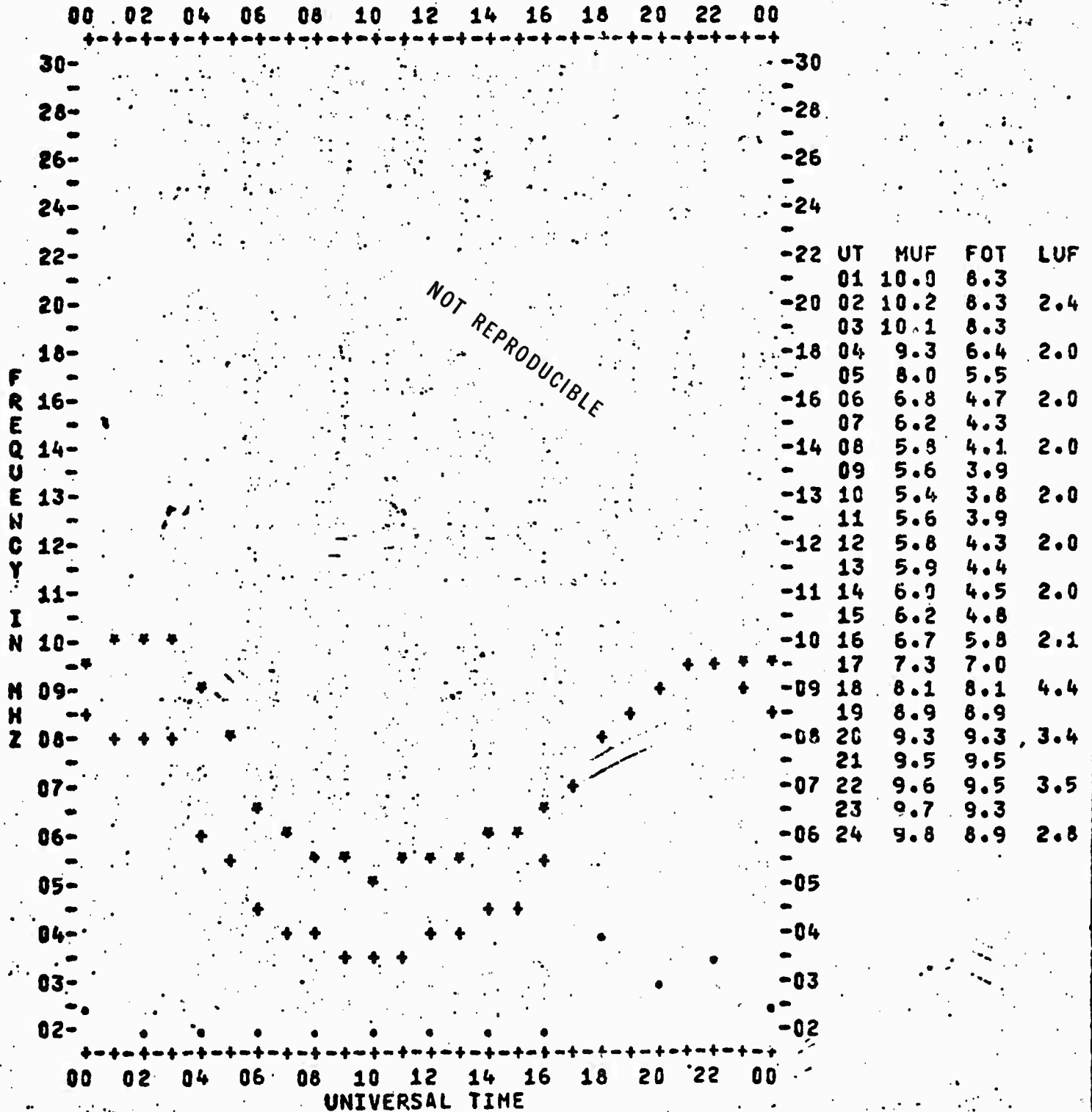

Figure 3. HF Propagation Prediction Program Graph

antenna since it is economical and easily erected. A narrow band FSK modulation was selected since this would: conserve band width (allowing room for many stations in a standard voice channel); provide acceptable data rates; and is the type recommended for the National Data Buoy Program⁽³⁾. Using these data as inputs to the program and selecting typical transmission paths, predictions were obtained for link reliability for the months of December, March and June. These months were selected because the amount of daylight over the transmission path affects the propagation characteristics and they cover the all dark, the all daylight and the half daylight-half dark months of the year. Figures 4, 5 and 6 summarize the data for a path of 600 n mi at an azimuth of approximately 90° from Barrow. If an arbitrary reliability of 80% is chosen, it can be seen that the lower frequencies (3-6 MHz) are best during December, with the mid frequencies (6-7 MHz) best during March and somewhat higher frequencies (6-12 MHz) best in June. A compromise frequency between 6 and 7 MHz was chosen since it: provides a good reliability during all seasons; is compatible with an existing "oceanographic data service" frequency in the band; and the antenna height for a vertical $1/4$ -wave is reasonable (about 40 feet). Path lengths less than 300 n mi favor lower frequencies. If the RAMS station is expected to be in one of those zones for a large portion of its life, two other oceanographic data service frequencies are available. These are in the 4-5 MHz and 8-9 MHz bands. The final RAMS station will be capable of operation at these frequencies and may be switched via an aircraft VHF or shore HF command link. A path of 600 n mi will be used for the first test of the RAMS link starting in late November 1971.

Transmitter

The transmitter is shown in block diagram form in Figure 7. The memory output drives an FSK modulator. The modulator will use center frequencies compatible with standard Defense Communication Agency (DCA) teletype

December

	3	4	5	6	7	8	9	10	11	12	14
Frequency - MHz Univer- sal Time											
02	96	97	97	91	80	68	58	49	42	36	26
04	93	93	93	90	85	77	70	62	55	49	37
06	84	86	86	85	82	77	72	67	62	56	46
08	91	91	91	91	89	86	81	76	71	65	53
10	91	91	92	91	90	87	83	79	74	68	57
12	89	89	88	88	88	85	83	79	75	69	59
14	80	78	78	78	78	76	74	72	67	63	52
16	82	82	82	80	78	75	70	66	60	54	42
18	85	87	88	84	78	70	63	56	49	43	32
20	91	93	94	90	82	69	58	49	42	36	25
22	90	94	95	95	90	85	75	63	49	36	21
24	98	99	99	98	96	90	80	66	50	34	21

Figure 4. HF Link Reliabilities in Percent

March

	3	4	5	6	7	8	9	10	11	12	14
Frequency - MHz Univer- sal Time											
02	76	83	88	87	88	83	67	47	39	32	22
04	84	87	88	85	78	68	57	47	40	32	26
06	78	77	77	77	71	64	56	49	43	39	31
08	76	75	75	72	70	67	64	61	57	53	45
10	72	70	69	69	69	68	68	65	64	60	53
12	77	74	73	72	71	69	67	64	61	57	48
14	68	69	68	66	63	59	56	51	42	42	33
16	63	69	69	70	66	60	49	42	36	31	21
18	38	40	57	60	62	63	44	35	26	18	12
20	41	73	75	83	85	86	86	39	31	24	15
22	39	72	75	83	85	86	87	36	30	24	15
24	56	84	89	92	93	93	66	43	35	29	19

Figure 5. HF Link Reliabilities in Percent

June

	3	4	5	6	7	8	9	10	11	12	14
Frequency - MHz Univer- sal Time											
02	0	62	72	90	92	94	91	92	78	58	46
04	22	74	82	91	92	89	90	90	81	69	53
06	61	71	76	78	79	81	79	74	67	59	47
08	65	76	77	79	81	78	74	69	63	57	46
10	54	68	71	74	76	74	70	66	60	55	45
12	53	59	71	76	80	80	77	70	65	60	48
14	31	67	79	82	84	87	89	81	76	69	53
16	0	66	71	82	85	86	77	82	85	78	60
18	0	54	61	79	83	84	72	75	79	75	60
20	0	14	64	66	92	93	94	85	88	89	57
22	0	13	62	69	92	93	94	87	87	89	45
24	0	19	67	75	91	92	93	94	86	61	40

Figure 6. HF Link Reliabilities in Percent

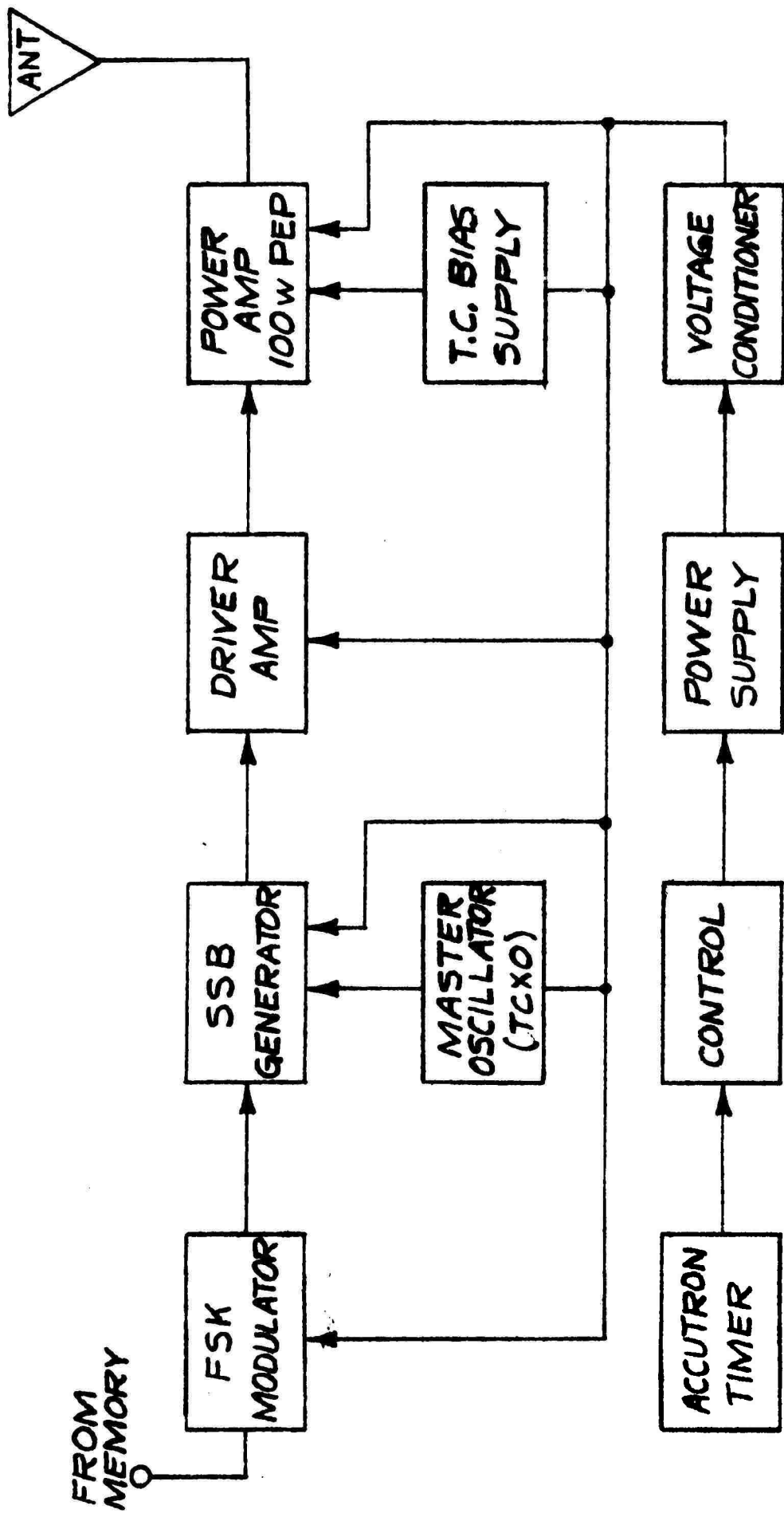

BLOCK DIAGRAM OF TRANSMITTER

FIG. 7

modems and will use ± 85 Hz frequency shift. This combination will allow data rates up to 150 baud, however it is anticipated that data rates of 100 baud or less will be used to minimize multipath problems in HF propagation. The FSK modulator provided the tone drive for this single side band generator. The SSB generators output frequency is synthesized from the TCXO master oscillator. The TCXO has a stability of 5×10^{-7} which translates to a frequency error of no greater than ± 4 Hz at the operating frequency. The SSB generator uses triple conversion to minimize spurious products. The output of the SSB generator is the final transmitted frequency which will be normally between 6 and 7 MHz but will be capable of being switched to the 4 to 5 MHz and the 8 to 9 MHz bands. The SSB generator low level output is then boosted to a level sufficient to drive the final power amplifier. The power amplifier provides 100 watts PEP or CW to the antenna. Both the driver and power amplifier are broad band linear amplifiers which will not require tuning at any of the operating frequencies. A temperature compensated bias supply will keep the output level of the transmitter constant. The voltage conditioner will regulate the output of the TE cell or AC generator and provide the necessary levels to the electronics.

The Accutron timer is a very stable electric clock which provides a contact closure once each hour for 4 minutes. The closures will be digitally divided down to produce a turn on cycle of once every 3, 4 or 6 hours. The balance of the control circuits provide the necessary start and stop functions for the generator.

Antennas

Candidate antennas for the transmitting station are a 1/4-wave Vertical Ground Plane (VGP) (Figure 8), a Directional Discontinuity Ring Radiator (DDRR) (Figure 9) and a Turnstile. These antennas are being tested prior

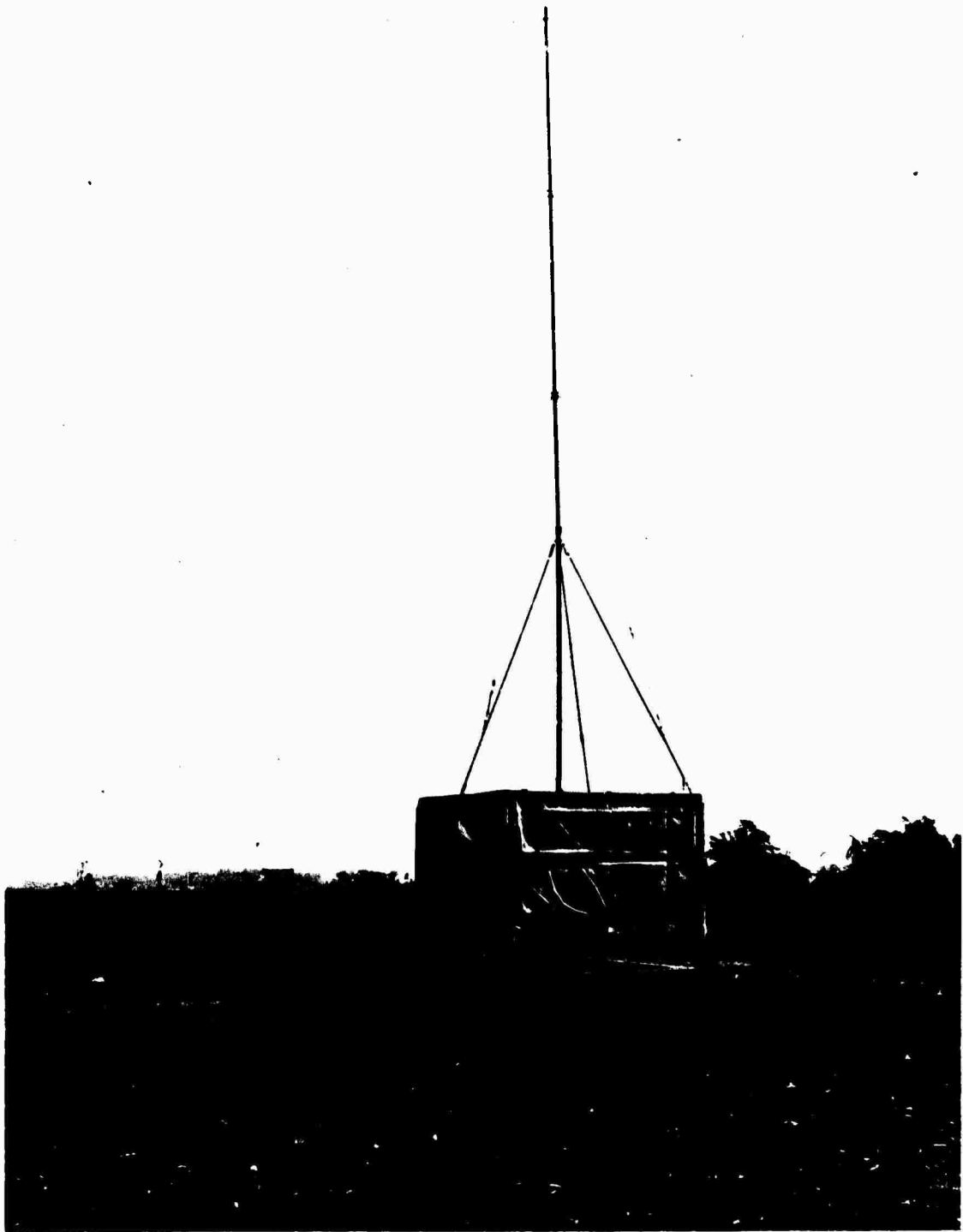

Figure 8. 1/4-Wave Vertical Ground Plane Antenna Atop Wanigan



Figure 9. Directional Discontinuity Ring Radiator Antenna Atop Wanigan

to installation of the test system and the most promising one will be used for the long-term tests in the Arctic. Ice break-up makes it desirable to have a minimum horizontal profile; for this requirement the DDDR is preferred. However, this antenna is somewhat controversial and not much performance test data have been published. It is also approximately 3 db less efficient than the other two antennas. The 1/4-wave VGP and Turnstile antennas have approximately the same horizontal profile but the 1/4-wave VGP is 40 feet high. However, loss of one or two of the 1/4-wave VGP radials due to ice damage will not have a large effect on the pattern while loss of one leg of the Turnstile will have an appreciable effect on its pattern. All of the above antennas can be designed to operate on the three bands through the use of loading coils or matching networks.

Power Supply and Housing

Batteries of all available types were considered for the RAMS power supply but all were discarded for one or more reasons involving cost, size, temperature and installation difficulty in favor of fossil fueled generators. Two candidate power supplies utilizing propane, a fuel readily available at Barrow, were selected for development and tests. The first is a thermoelectric generator providing continuous 8 watts of output. It costs about \$800, requires one 100-lb propane bottle per two-month period and has electric restart capability. The second is a three kilowatt, four cycle gasoline engine-alternator, converted to propane, costing about \$700.00. The latter supply is normally off and turned on with an electric timer at the transmission period. Inside a well-insulated housing and with a suitable heat exchanger, the generator will generate and hold enough heat to keep the housing above 0°C. Figure 10 is a close-up of a typical housing showing the TE cell undergoing tests at Delco, Santa Barbara. This structure is a short version of the regular NARL prefabricated 8 x 8 foot wanigan. Figure 11 is a smaller

structure (5 x 4 x 5 feet) on which is mounted the DDDR antenna. Inside the housing is a 3 kilowatt engine-alternator that was cycled for four minutes hourly without failure for 16 days. This is equivalent to 64 days operation at a 4-hour cycle and 96 days at a 6-hour cycle. The unit stopped at this point due to a starter motor failure. The starter motor had been overstressed prior to the test and it is probable that this contributed substantially to its failure. It has been tested for starting in a cold chamber at -20°C . This engine-alternator is particularly attractive since it will enable a transmitter power of 10 times the TE cell with enough surplus to power, for example, a small hydrographic winch or charge batteries for sensor heating, etc. As noted before, it has the further advantage of costing somewhat less than the TE cell.

References

- (1) B. M. Buck and W. P. Brown, "An Experiment with a Short Path Length Unattended Troposcatter Telemetry Link in the Arctic Ocean", Proceedings of the National Telemetry Conference, June 1964
- (2) S. M. Olenicoff, "The Soviet DARMS", AIDJEX Bulletin No. 7, April 1971
- (3) ESSA Technical Report ERL172-ITS-110, page 48