

AFRRI SR71-12  
SEPTEMBER 1971

**AFRRI**  
**SCIENTIFIC**  
**REPORT**

THE MEASUREMENT OF CAPILLARY  
PERMEABILITY CHANGES IN  
THE IRRADIATED RAT USING  
A DOUBLE ISOTOPE TECHNIQUE

AFRRI SR71-12

ARMED FORCES RADIOBIOLOGY RESEARCH INSTITUTE  
Defense Nuclear Agency  
Bethesda, Maryland

Approved for public release; distribution unlimited

All aspects of investigative programs involving the use of laboratory animals sponsored by DoD components are conducted according to the principles enunciated in the "Guide for Laboratory Animal Facilities and Care", prepared by the National Academy of Sciences - National Research Council.

THE MEASUREMENT OF CAPILLARY PERMEABILITY CHANGES  
IN THE IRRADIATED RAT USING A DOUBLE ISOTOPE TECHNIQUE

M. M. GRAHAM



S. J. BAUM  
Chairman  
Experimental Pathology Department



M. I. VARON  
Captain MC USN  
Director

ARMED FORCES RADIOBIOLOGY RESEARCH INSTITUTE  
Defense Nuclear Agency  
Bethesda, Maryland

## TABLE OF CONTENTS

	Page
Foreword (Nontechnical summary) . . . . .	iii
Abstract . . . . .	v
I. Introduction . . . . .	1
II. Methods and Materials . . . . .	1
Animals . . . . .	1
Isotopically labeled albumin . . . . .	1
Antiserotonin-antihistamine . . . . .	2
Irradiation . . . . .	2
Experimental procedure . . . . .	3
Statistical analysis . . . . .	4
III. Theory . . . . .	4
IV. Results . . . . .	9
V. Discussion . . . . .	11
References . . . . .	13

## LIST OF FIGURES

Figure 1. Model used to describe short-term behavior of radioactive iodinated albumin in the circulation of a rat . . . . .	5
Figure 2. Inherent error in the simplification of the model . . . . .	8
Figure 3. Capillary permeability area of rat small intestine following 800 rads fast electron irradiation . . . . .	9
Figure 4. Capillary permeability area of rat muscle following 800 rads fast electron irradiation . . . . .	10
Figure 5. Capillary permeability surface area product of rat small intestine after 10,000 rads cobalt-60 irradiation . . . . .	10

FOREWORD  
(Nontechnical summary)

Changes in capillary permeability shortly after irradiation are of interest because of the possible connection with radiation-induced incapacitation and with the generalized capillary fragility that may occur several days after irradiation.

A new technique using two types of radioactively labeled albumin was developed to measure capillary permeability in the small intestine and in skeletal muscle of the rat at various times after irradiation.

It was found that in rat small intestine there was an increase in capillary permeability immediately after 10,000 rads  $^{60}\text{Co}$  irradiation that could be completely abolished if the drug cyproheptadine was injected 30 minutes prior to irradiation. This drug is a powerful antagonist of histamine and serotonin, two substances that are known to increase capillary permeability and to dilate blood vessels. These results indicate that histamine or serotonin may be responsible for the initial increase in capillary permeability.

In rats exposed to 800 rads of 30 MeV electrons (LINAC) there was an initial increase in permeability followed by a return to normal levels. A second increase was measured beginning at 8 hours and leveling off at 24 hours. Thereafter the permeability remained relatively constant for several days and was not susceptible to treatment with cyproheptadine as measured 48 hours postirradiation. This indicates that the secondary increase is not due to histamine or serotonin. It may be due to structural defects that may lead to internal bleeding.

## ABSTRACT

Capillary permeability was measured using  $^{131}\text{I}$  albumin and  $^{125}\text{I}$  albumin to assay the movement of albumin out of the bloodstream into the interstitial fluid of small intestine and muscle of the irradiated rat. One hour after 800 rads 30 MeV electron whole-body irradiation, small intestine capillary permeability increased significantly, returned to normal levels in a few hours, and then after 8 hours increased and remained at 65 percent above control levels for several days. Muscle capillary permeability increased within 2 hours after irradiation and remained elevated for several days. Cyproheptadine, an antiserotonin-antihistamine, completely blocked a 45 percent increase in small intestine capillary permeability seen immediately after 10,000 rads  $^{60}\text{Co}$  irradiation but had little effect at 48 hours after irradiation.

## I. INTRODUCTION

Capillary permeability in the rat increases immediately following midlethal whole-body ionizing irradiation, returns to normal levels within a few hours, and then increases and remains elevated for several days.<sup>3</sup> As has been reported, the initial changes might be due to the liberation of serotonin<sup>15</sup> and histamine<sup>3, 5, 8, 15</sup> from mast cells immediately following irradiation. The late changes could be the manifestation of structural defects in the capillary endothelium several days later. Since both serotonin and histamine have been considered as the agents responsible for the early changes in capillary permeability, it is possible that a drug which blocks the action of both serotonin and histamine could be particularly effective in abolishing the increase in capillary permeability immediately after irradiation. This was tested, using a double isotope technique to measure the movement of albumin out of the bloodstream into the interstitial fluid of the small intestine in the presence and absence of an antiserotonin-antihistamine drug.

## II. METHODS AND MATERIALS

Animals. Male Sprague-Dawley rats individually housed in wire mesh cages and weighing 280-350 g were used in this study. These rats were allowed free access to food and water.

Isotopically labeled albumin. 1 mCi <sup>131</sup>I human serum albumin (Albumotope I 131, E. R. Squibb) in a volume of 2 ml was dialyzed at 4°C against 1 liter 0.9 per-cent NaCl for 24 hours; and 0.25 mCi <sup>125</sup>I human serum albumin (Albumotope I 125, E. R. Squibb) in a volume of 5 ml was also dialyzed at 4°C against 1 liter 0.9 per-cent NaCl for 24 hours.

After such dialysis, less than 1 percent of the radioactive iodine remained in solution when assayed by the precipitation of the protein by cold 10 percent trichloroacetic acid.<sup>3</sup>

In preliminary experiments, undialyzed albumin was injected into a rat and after 1 hour the rat was bled and the plasma was used. Since the results with that plasma were similar to the results with the dialyzed albumin, the latter was used in the subsequent work reported here. Both albumins were diluted with 0.9 percent NaCl to about 20  $\mu$ Ci/ml for injection.

Antiserotonin-antihistamine. In some experiments, 0.1 mg/kg of cyproheptadine was given subcutaneously 30 minutes prior to the injection of <sup>131</sup>I albumin.

Irradiation. In the first experiment the rats were irradiated in groups of six by a water-scattered 30 MeV linear accelerator (LINAC) electron beam. The dose was delivered in 4- $\mu$ sec pulses, 40 rads per pulse, 20 pulses in 20 seconds for a total whole-body dose of 800 rads  $\pm$  7 percent. It was measured with thermoluminescent dosimeters calibrated with cobalt-60.

For technical reasons the LINAC was unavailable, and therefore in the second experiment the rats were irradiated with a bilateral <sup>60</sup>Co source. A larger dose was chosen to assure a maximal change in capillary permeability. The rats received 10,000 rads  $\pm$  5 percent whole-body irradiation at 900 rads/minute.

The relative biological effectiveness for fast electrons to <sup>60</sup>Co gamma rays has been shown to be about 1 for a variety of systems including cultured mammalian cells<sup>12</sup> and mouse lethality.<sup>9</sup> Therefore, the results from the two sources should be comparable.

Experimental procedure. The rats were anesthetized with 6 mg Nembutal/100 g intraperitoneally. A polyethylene PE-50 cannula was inserted into the right jugular vein for injection of the isotopes and withdrawal of blood. First, about 1  $\mu$ Ci of  $^{131}\text{I}$  albumin was injected. This was followed 20 minutes later with an injection of about 1  $\mu$ Ci of  $^{125}\text{I}$  albumin. Each injection was washed in with about 0.1 ml physiological saline. About 10 ml of blood were withdrawn into a heparinized syringe via the cannula 30 minutes after the  $^{131}\text{I}$  albumin injection, following which the animal was sacrificed by creating a pneumothorax. The blood was then centrifuged and a 1-ml plasma sample was placed in a vial.

A sample of small intestine including most of the jejunum and part of the ileum was removed. The mesentery was stripped from the sample and the contents expressed. Part of the abdominal wall and the gluteus maximus from one leg were also taken as muscle samples. All samples were weighed wet and then digested with 3 M KOH at 60°C overnight. The  $^{125}\text{I}$  and  $^{131}\text{I}$  radioactivity of each sample was measured with a dual channel scintillation counter. The resulting data were used to calculate the capillary permeability surface area product (PS) per gram of tissue for each tissue sample (see section III. Theory).

PS, as used by Garlick and Renkin,<sup>1</sup> is defined by Fick's law:  $F = PS \cdot \Delta C$  where F is the flux of a solute through a membrane and  $\Delta C$  is the concentration difference across the membrane for that solute.

The term capillary permeability has frequently been used in the literature to mean capillary PS as just defined. For the sake of brevity, capillary permeability is

used occasionally in this paper but should always be taken to mean the capillary permeability surface area product.

In the first experiment, using the LINAC, the experimental procedure was conducted on groups of rats at various times after irradiation to follow the changes in capillary PS.

In the second experiment, using  $^{60}\text{Co}$  irradiation, the procedure was conducted immediately after irradiation (0-time group) and 48 hours later. Half of the 0-time group received 0.1 mg/kg of cyproheptadine subcutaneously 30 minutes before irradiation. Just before irradiation, all the animals in the group were injected with  $^{131}\text{I}$  albumin and then irradiated. Irradiation took about 11 minutes, leaving adequate time to complete the rest of the procedure.

Half of the 48-hour group received 0.1 mg/kg of cyproheptadine 30 minutes prior to the injection of  $^{131}\text{I}$  albumin.

Statistical analysis. The Mann-Whitney  $U$  test<sup>11</sup> was used throughout to evaluate the statistical significance of the differences between groups. Significance was assigned at the 5 percent level.

### III. THEORY

The short-term behavior of tracer albumin in the circulation of the rat can be described using a multiple compartment model (Figure 1). Immediately after injection, all the radioactive albumin is in the plasma compartment. It then begins to move into the other compartments that represent the interstitial fluid in various tissues. This movement occurs at a different rate for each tissue, depending on its characteristic PS. Eventually the albumin is returned to the circulation via the lymph.

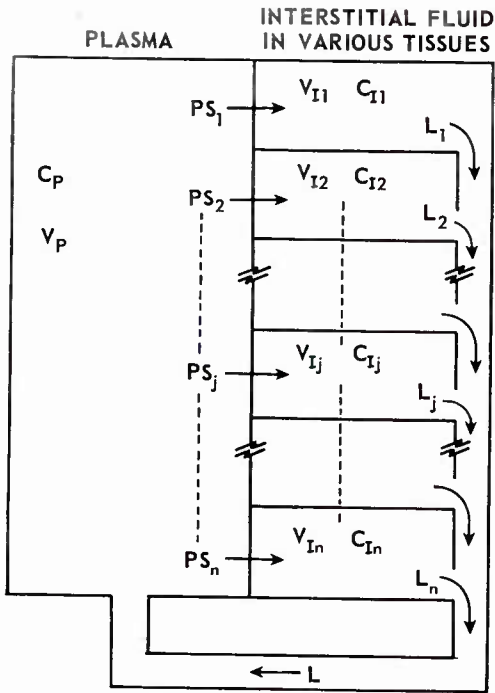

Figure 1. Model used to describe short-term behavior of radioactive iodinated albumin in the circulation of a rat.

$C$  = concentration of radioactive albumin in the indicated compartment

$V$  = volume of the indicated compartment

$P$  = permeability of capillary walls (cm/min)

$S$  = surface area of capillary walls available for exchange

$L$  = lymph flow for the indicated compartment

It is assumed that the animal has an average capillary permeability area that determines the level of tracer albumin in the plasma, but that the permeabilities of the various tissues can differ. An average permeability for the whole animal seems reasonable since the disappearance curve for iodinated albumin in the circulation of the rat is a single exponential for the first few hours after injection.<sup>14</sup>

The differential equations describing the time course of the concentration of radioactive albumin in the plasma ( $C_p$ ) and in the average interstitial fluid ( $C_I$ ) are:

$$\frac{dC_p}{dt} = \frac{-PS(C_p - C_I) + L \cdot C_I}{V_p} \quad (1)$$

$$\frac{dC_I}{dt} = \frac{PS(C_p - C_I) - L \cdot C_I}{V_I} \quad (2)$$

$L$  is the whole-body lymph flow,  $V_p$  is the plasma volume and  $V_I$  is the interstitial fluid volume.  $PS$  is the average capillary permeability surface area product for the entire animal in equations (1) and (2).

In a particular tissue (subscripted  $j$ ) the pertinent equation is:

$$\frac{dC_{Ij}}{dt} = \frac{PS_j(C_p - C_{Ij}) - L_j \cdot C_{Ij}}{V_{Ij}} \quad (3)$$

By introducing the following three simplifying assumptions this relatively complex model becomes experimentally useful: (1) the concentration of tracer albumin in the plasma ( $C_p$ ) remains relatively constant during the course of the experiment;<sup>6</sup> (2) the concentration of tracer albumin in the interstitial fluid ( $C_I$ ) remains relatively low during the course of the experiment; and (3) lymph flow is negligible. These assumptions are justified later.

Equations (1), (2) and (3) now become:

$$\frac{dC_p}{dt} = 0 \quad (4)$$

$$\text{Whole animal: } \frac{dC_I}{dt} = \frac{PS \cdot C_p}{V_I} \quad (5)$$

$$\text{Particular tissue: } \frac{dC_{Ij}}{dt} = \frac{PS_j \cdot C_p}{V_{Ij}} \quad (6)$$

The solution for equation (6) is:

$$C_{Ij} = \frac{PS_j \cdot C_p \cdot t}{V_{Ij}} \quad (7)$$

In a particular sample of tissue there exists a given interstitial fluid volume ( $V_{Ij}$ ) and a given residual intravascular plasma volume ( $V_{Rj}$ ). The total activity (A) of a sample of tissue would then be:

$$A = V_{Ij} \cdot C_{Ij} + V_{Rj} \cdot C_p \quad (8)$$

$$A = PS_j \cdot C_p \cdot t + V_{Rj} \cdot C_p \quad (9)$$

Since the  $^{131}\text{I}$  albumin circulates for 30 minutes and the  $^{125}\text{I}$  albumin circulates for 10 minutes, two separate equations can be written dropping the individual tissue subscripts:

$$A^{131} = PS \cdot C_p^{131} \cdot 30 + V_R \cdot C_p^{131} \quad (10)$$

$$A^{125} = PS \cdot C_p^{125} \cdot 10 + V_R \cdot C_p^{125} \quad (11)$$

The solution for PS for a particular tissue sample, using the simplified model, is then

$$PS = \frac{1}{20} \left( \frac{A^{131}}{C_p^{131}} - \frac{A^{125}}{C_p^{125}} \right) \quad (12)$$

The simplified model was compared with the more complex model to estimate the inherent error introduced in the simplification. A computer program was written using equations (1), (2) and (3) as difference equations with a step increment of 1 minute. A total plasma volume of 3 percent of body weight and an interstitial fluid volume of 30 percent of body weight were used. Given various average and particular tissue permeability areas, residual plasma volumes and lymph flows, the program calculated the levels of tracer albumin at 10 and 30 minutes after injection. These values were substituted into equation (12) and PS was calculated. The ratio of calculated

tissue PS to given tissue PS is shown in Figure 2 for several values of the various variables. The range of these variables exceeds their range as reported in the literature<sup>6,7</sup> or as observed during the course of these experiments. Within this range the calculated values do not differ from the given values by more than 16 percent.

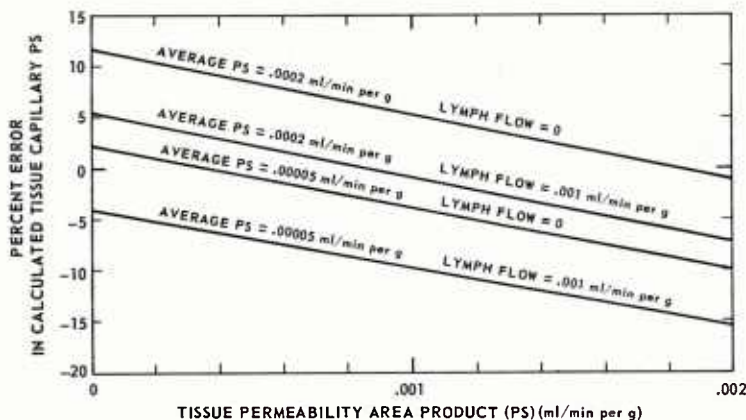

Figure 2. Inherent error in the simplification of the model. A relatively complete model was used to calculate the concentration of radioactive albumin in the plasma and in the tissues at 10 and 30 minutes after injection for the range of values indicated. The resulting data were used to calculate PS using an equation derived from the simplified model. The error indicated is the deviation from unity of the ratio of tissue capillary PS calculated using the simplified model to the PS used in the complete model. The ranges for the various variables exceed that expected or observed.

The residual plasma volume introduces no theoretical error but, because of the random nature of radioactive decay, is responsible for much of the experimental error in the procedure. In equation (12) we take the difference between two count ratios. If the difference is small, the error may represent an important fraction of the difference. For example, muscle PS is about one-sixth that of small intestine and the standard deviation for muscle PS is 85 percent of the mean while it is only 35 percent for small intestine. Both of these errors are greater than the 16 percent error expected because of the simplification of the model.

An additional source of error arises in the group of rats that were evaluated just after the 10,000-rad  $^{60}\text{Co}$  exposure. During the course of the procedure, capillary permeability probably changed considerably and, since the calculation assumes steady state, the calculated PS was probably in considerable error. Because of this error the computation was primarily valuable for defining differences between groups rather than calculating absolute values for this group.

#### IV. RESULTS

The capillary permeability areas (PS's) were determined for small intestine and muscle between 1 and 216 hours (9 days) after 800 rads whole-body fast electron irradiation. The small intestine PS (Figure 3) increased significantly by 1 hour after irradiation, returned briefly to control levels at 2 through 4 hours, was again increased at 8 hours, and remained elevated for several days. Muscle PS (Figure 4) became significantly elevated by 2 hours after irradiation and remained elevated for several days.

In the second experiment the effect of cyproheptadine on postirradiation PS changes was examined (Figure 5). Cyproheptadine blocks the action of serotonin and

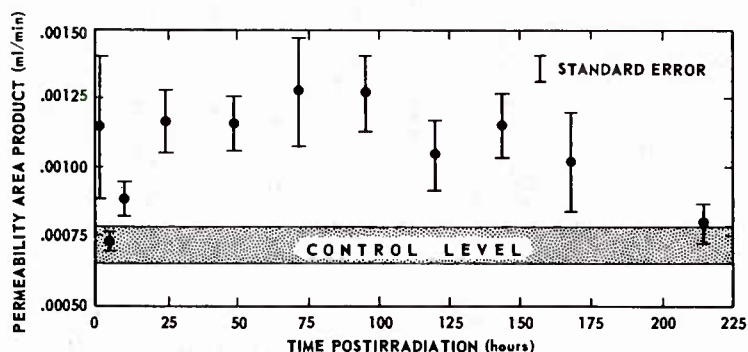

Figure 3. Capillary permeability area of rat small intestine following 800 rads fast electron irradiation. All points excepting the ones at 4, 168 and 216 hours are significantly above control.

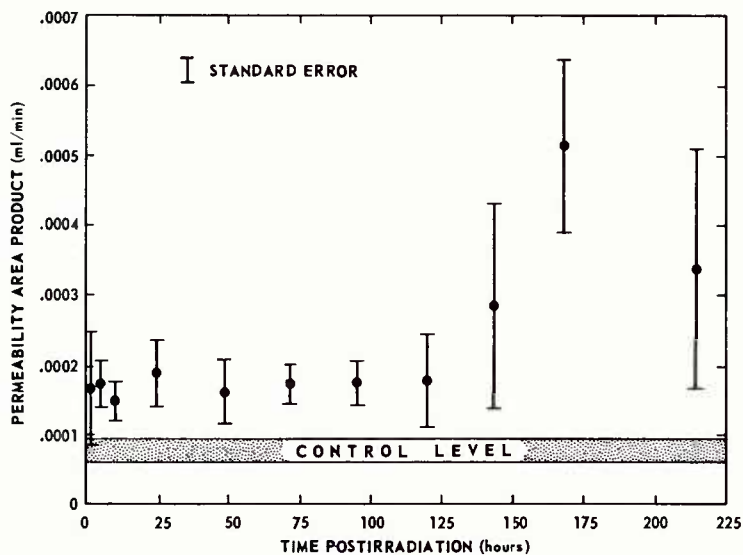

Figure 4. Capillary permeability area of rat muscle following 800 rads fast electron irradiation. All points excepting the ones at 1, 120, 144 and 216 hours are significantly above control.

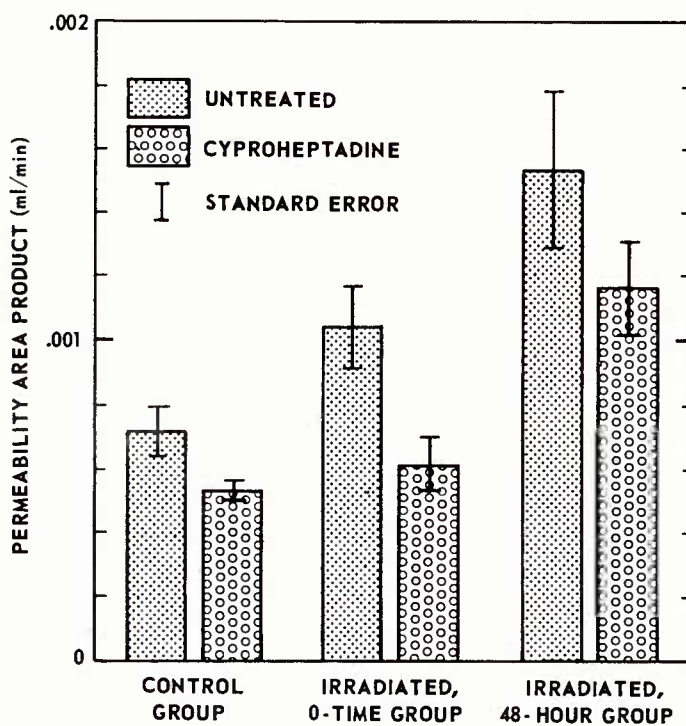

Figure 5. Capillary permeability surface area product of rat small intestine after 10,000 rads cobalt-60 irradiation. The treated groups were injected subcutaneously with 0.1 mg/kg cyproheptadine 30 minutes prior to the beginning of the measurement of the capillary permeability area.

histamine.<sup>2,13</sup> There was a small but significant decrease in small intestinal PS in the treated control animals. For the animals killed 30 minutes following exposure to 10,000 rads <sup>60</sup>Co irradiation, cyproheptadine completely prevented the increase in PS seen in untreated animals. Cyproheptadine significantly reduced but did not completely reverse the increase in PS seen in untreated animals 48 hours postirradiation.

## V. DISCUSSION

Following 800 rads whole-body fast electron irradiation, the small intestine capillary permeability area was assessed by measuring the movement of radioactive iodinated albumin into tissue using a double isotope technique. It increased by 60 percent immediately after irradiation, returned to normal within a few hours, and then increased again and remained at about 65 percent above normal for several days. After day 6, the permeability area of surviving rats returned toward control levels which may reflect recovery from radiation damage. The biphasic behavior is in accord with the observations of Harris and Noonan,<sup>3</sup> who used the appearance of intravascularly injected radioactive albumin in the peritoneal fluid of rats to measure capillary permeability following irradiation.

The prolonged plateau in the small intestine capillary PS for several days after irradiation has not been previously reported. This plateau may indicate that the radiation damage, such as deterioration of the basement membrane<sup>16</sup> surrounding the capillaries, may manifest itself within a few days after irradiation and then remain relatively constant until it is repaired several days later. Alternatively there could be a progressive deterioration of the capillaries<sup>16</sup> leading to an increase in capillary permeability, but at the same time there may be a decrease in the area available for

exchange due to progressive vasoconstriction.<sup>4</sup> Thus the capillary permeability area could remain relatively constant for several days.

The data for muscle capillary PS following 800 rads electron irradiation are not explicit enough to draw any conclusions except that it is definitely elevated for several days after irradiation.

Both serotonin and histamine are contained in the mast cells in rats, and these cells discharge their granules containing these substances at the time of irradiation.<sup>10</sup> In rats, serotonin is more effective than histamine in increasing capillary permeability.<sup>2</sup> Cyproheptadine, a surmountable, competitive inhibitor of serotonin and histamine<sup>2, 13</sup> caused a slight drop in the small intestine capillary permeability area in unirradiated animals. This would be consistent with the inhibition of circulating histamine or serotonin. Cyproheptadine completely blocked the 45 percent increase in small intestine capillary PS immediately following 10,000 rads, but was only slightly effective 48 hours later.

Other investigators have found antihistamines to be effective in blocking the increased capillary permeability at 24 hours after irradiation in the rabbit<sup>8</sup> and in the rat,<sup>15</sup> and ineffective at 90 minutes in the rabbit<sup>5</sup> and at 6 hours in the rat.<sup>3</sup> An anti-serotonin was found to be ineffective in the rat when tested 24 hours after irradiation.<sup>15</sup>

If these experiments are comparable, then serotonin may be responsible for the initial increase in capillary permeability in the rat, histamine may account for the observed increase at 24 hours, and structural defects<sup>16</sup> or some other mechanism may cause the prolonged increase after 48 hours. Further work using standardized conditions should test this.

## REFERENCES

1. Garlick, D. G. and Renkin, E. M. Transport of large molecules from plasma to interstitial fluid and lymph in dogs. *Am. J. Physiol.* 219:1595-1605, 1970.
2. Goodman, L. S. and Gilman, A., editors, 4th ed. *The Pharmacological Basis of Therapeutics*, pp. 647, 655. New York, N. Y., The Macmillan Company, 1970.
3. Harris, J. W. and Noonan, T. R. Early vascular permeability changes in whole-body X-irradiated rats. *Radiation Res.* 34:357-365, 1968.
4. Janossy, Gy. Intestinal blood flow in gastrointestinal irradiation syndrome in the rat. *Acta Med. Acad. Sci. Hung.* 26(1):13-21, 1969.
5. Jolles, B. and Harrison, R. G. Enzymic processes and vascular changes in the skin radiation reaction. *Brit. J. Radiol.* 39:12-18, 1966.
6. Mayerson, H. S. The physiologic importance of lymph. In: *Handbook of Physiology*, Vol. II, Section 2. Circulation. Washington, D. C., American Physiological Society, 1963.
7. Mayerson, H. S., Wolfram, C. G., Shirley, H. H., Jr. and Wasserman, K. Regional differences in capillary permeability. *Am. J. Physiol.* 198:155-160, 1960.
8. Mount, D. and Bruce, W. R. Local plasma volume and vascular permeability of rabbit skin after irradiation. *Radiation Res.* 23:430-445, 1964.
9. Robinson, E. RBE in depth of high-energy electrons using cell cultures. In: *Frontiers of Radiation Therapy and Oncology*, Vol. 2: Electron Beam Therapy, Proceedings of the Second Annual San Francisco Cancer Symposium, Vaeth, J. M., editor. Basel (Switzerland) and New York, S. Karger, 1968.
10. Selye, H. *The Mast Cells*, pp. 222, 320. Baltimore, Maryland, Waverly Press, 1965.
11. Siegel, S. *Nonparametric Statistics for the Behavioral Sciences*, p. 116. New York, N. Y., McGraw-Hill Book Company, Inc., 1956.
12. Sinclair, W. K. and Kohn, H. I. The RBE of high energy photons and electrons. *Radiology* 82:800-815, 1964.
13. Stone, C. A., Wenger, H. C., Ludden, C. T., Stavorski, J. M. and Ross, C. A. Antiserotonin-antihistamin properties of cyproheptadine. *J. Pharmacol. Exptl. Therapy* 131:73-84, 1961.

14. Wasserman, K. and Mayerson, H. S. Exchange of albumin between plasma and lymph. *Am. J. Physiol.* 165:15-26, 1951.
15. Willoughby, D. A. Pharmacological aspects of the vascular permeability changes in the rat's intestine following abdominal radiation. *Brit. J. Radiol.* 33:515-519, 1960.
16. Zweifach, B. W. and Kivy-Rosenberg, E. Microcirculatory effects of whole-body X-irradiation and radiomimetic procedures. *Am. J. Physiol.* 208:492-498, 1965.

## DISTRIBUTION LIST

### AIR FORCE

The Surgeon General, U. S. Department of the Air Force, Washington, D. C. 20314 (1)  
Executive Officer, Director of Professional Services, Office of the Surgeon General, Hq. USAF (AFMSPA),  
Washington, D. C. 20314 (1)  
Headquarters, U. S. Air Force (AFMSPAB), Washington, D. C. 20314 (1)  
USAFSAM (RA), ATTN: Chief, Radiobiology Division, Brooks AFB, Texas 78235 (1)  
USAFSAM, ATTN: EDAD, Brooks AFB, Texas 78235 (1)  
Air Force Weapons Laboratory, ATTN: WLIL (1), ATTN: WLRB-2 (1), Kirtland AFB, New Mexico 87117 (2)  
Chief, Nuclear Medicine Department, P. O. Box 5088, USAF Hospital, Wright-Patterson AFB, Ohio 45433 (1)  
Office of the Command Surgeon (ADCSG), Hq. ADC, USAF, Ent AFB, Colorado 80912 (1)

### ARMY

The Surgeon General, U. S. Department of the Army, Washington, D. C. 20314 (1)  
Surgeon General, ATTN: MEDDH-N, U. S. Department of the Army, Washington, D. C. 20314 (1)  
USACDC CSSG, Doctrine Division, Fort Lee, Virginia 23801 (1)  
CG, USCONARC, ATTN: ATUTR-TNG (NBC), Fort Monroe, Virginia 23351 (1)  
Commanding Officer, U. S. Army Medical Research Laboratory, Fort Knox, Kentucky 40121 (1)  
Commanding Officer, USA Nuclear Medical Research Detachment, Europe, APO New York, N. Y. 09180 (2)  
Army Research Office, ATTN: Chief, Scientific Analysis Branch, Life Sciences Division, 3045 Columbia Pike,  
Arlington, Virginia 22204 (1)  
Division of Nuclear Medicine, Walter Reed Army Institute of Research, Walter Reed Army Medical Center  
Washington, D. C. 20012 (5)  
Commanding Officer, U. S. Army Environmental Hygiene Agency, ATTN: USAEHA-RP, Edgewood Arsenal, Mary-  
land 21010 (1)  
Commandant, U. S. Army Medical Field Service School, ATTN: MEDEW-ZNW, Fort Sam Houston, Texas 78234 (1)

### NAVY

Chief, Bureau of Medicine and Surgery, U. S. Navy Department, Washington, D. C. 20390 (1)  
Chief, Bureau of Medicine and Surgery, ATTN: Code 71, U. S. Navy Department, Washington, D. C. 20390 (1)  
Director, Biological Sciences Division, Office of Naval Research, Washington, D. C. 20360 (1)  
Commanding Officer, Naval Aerospace Medical Institute, NAMC, ATTN: Research Director, Pensacola, Florida  
32512 (3)  
Head, Animal Behavioral Sciences Branch, Naval Aerospace Medical Institute, Naval Aerospace Medical Center,  
ATTN: Dr. John S. Thach, Jr., Pensacola, Florida 32512 (1)  
Commanding Officer, U. S. Naval Hospital, ATTN: Director, REEL, NNMC, Bethesda, Maryland 20014 (1)  
Commanding Officer, Nuclear Weapons Training Center, Atlantic, Nuclear Warfare Department, Norfolk, Virginia  
23511 (1)  
Commanding Officer, Naval Submarine Medical Center, Naval Submarine Base, NL, ATTN: Medical Library,  
Groton, Connecticut 06340 (1)  
Commanding Officer, Naval Submarine Medical Center, Naval Submarine Base, NL, ATTN: Code 53, Nuclear Medi-  
cine Training Division, Groton, Connecticut 06340 (1)

### D. O. D.

Director, Defense Nuclear Agency, Washington, D. C. 20305 (1)  
Director, Defense Nuclear Agency, ATTN: DDST, Washington, D. C. 20305 (1)  
Director, Defense Nuclear Agency, ATTN: Chief, Medical Directorate, Washington, D. C. 20305 (4)  
Director, Defense Nuclear Agency, ATTN: Technical Library (APTL), Washington, D. C. 20305 (2)  
Commander, Field Command, Defense Nuclear Agency, ATTN: FC Technical Library, Kirtland AFB, New Mexico  
87117 (1)  
Director, Armed Forces Institute of Pathology, Washington, D. C. 20305 (1)  
Administrator, Defense Documentation Center, Cameron Station, Bldg. 5, Alexandria, Virginia 22314 (12)

### OTHER GOVERNMENT

U. S. Atomic Energy Commission, Headquarters Library, Reports Section, Mail Station G-17, Washington, D. C.  
20545 (1)  
U. S. Atomic Energy Commission, Division of Biology and Medicine, Washington, D. C. 20545 (1)  
U. S. Atomic Energy Commission, Bethesda Technical Library, 7920 Norfolk Avenue, Bethesda, Maryland 20014 (1)

OTHER GOVERNMENT (continued)

- National Aeronautics and Space Administration, ATTN: Lt. Col. Charles M. Barnes, USAF, DB-3, MSC, Houston, Texas 77058 (1)
- National Aeronautics and Space Administration, Manned Spacecraft Center, ATTN: Dr. B. D. Newsom, Mail Code DA, Houston, Texas 77058 (1)
- National Bureau of Standards, ATTN: Chief, Radiation Physics Division, Washington, D. C. 20234 (1)
- U. S. Public Health Service, Bureau of Radiological Health, Division of Biological Effects, 12720 Twinbrook Parkway, Rockville, Maryland 20852 (1)
- U. S. Public Health Service, Bureau of Radiological Health, Library, 12720 Twinbrook Parkway, Rockville, Maryland 20852 (1)
- U. S. Public Health Service, Northeastern Radiological Health Laboratory, 109 Holton Street, Winchester, Massachusetts 01890 (1)
- U. S. Public Health Service, Southeastern Radiological Health Laboratory, P. O. Box 61, Montgomery, Alabama 36101 (1)
- U. S. Public Health Service, Southwestern Radiological Health Laboratory, P. O. Box 15027, Las Vegas, Nevada 89114 (1)

OTHER

- Argonne National Laboratory, Library Services Department, Report Section Bldg. 203, RM-CE-125, 9700 South Cass Avenue, Argonne, Illinois 60440 (1)
- Dr. Donald G. Baker, Radiobiology Department, Zellerbach Saroni Tumor Institute, 1600 Divisadero Street, San Francisco, California 94115 (1)
- Dr. J. T. Brennan, Radiology Department, University of Pennsylvania, 3400 Spruce Street, Philadelphia, Pennsylvania 19104 (1)
- Brookhaven National Laboratory, Information Division, ATTN: Research Library, Upton, Long Island, New York 11973 (2)
- Dr. J. S. Burkle, Director of Nuclear Medicine, York Hospital, York, Pennsylvania 17403 (1)
- Director, Radiobiology Laboratory, University of California, Davis, California 95616 (1)
- University of California, Lawrence Radiation Laboratory, Library, Bldg. 50, Room 134, Berkeley, California 94720 (1)
- University of California, Lawrence Radiation Laboratory, Technical Information Division Library L-3, P. O. Box 808, Livermore, California 94551 (2)
- University of California, Laboratory of Nuclear Medicine and Radiation Biology, Library, 900 Veteran Avenue, Los Angeles, California 90024 (1)
- Cdr. William H. Chapman, USN (Ret.), Bio-Medical Division L-523, Lawrence Radiation Laboratory, University of California, P. O. Box 808, Livermore, California 94551 (1)
- Director, Collaborative Radiological Health Laboratory, Colorado State University, Fort Collins, Colorado 80521 (1)
- Dr. L. W. Davis, Radiology Department, University of Pennsylvania, 3400 Spruce Street, Philadelphia, Pennsylvania 19104 (1)
- Professor Merrill Eisenbud, New York University, Tuxedo, New York 10987 (1)
- Dr. T. C. Evans, Radiation Research Laboratory, College of Medicine, University of Iowa, Iowa City, Iowa 52240 (1)
- Dr. Arnold Feldman, Institute of Radiology, School of Medicine, Washington University, 510 South Kingshighway, St. Louis, Missouri 63110 (1)
- Mr. Orin Gelderloos, Division of Literature, University of Michigan, Dearborn Campus, Dearborn, Michigan 48124 (1)
- General Dynamics/Fort Worth, ATTN: Librarian, P. O. Box 748, Fort Worth, Texas 76101 (1)
- Gulf General Atomic Incorporated, ATTN: Library, P. O. Box 608, San Diego, California 92112 (1)
- IIT Research Institute, ATTN: Document Library, 10 West 35th Street, Chicago, Illinois 60616 (1)
- Dr. R. F. Kallman, Department of Radiology, Stanford University, Palo Alto, California 94305 (1)
- Dr. L. S. Kelly, Donner Laboratory, University of California at Berkeley, Berkeley, California 94720 (1)
- Los Alamos Scientific Laboratory, ATTN: Report Librarian, P. O. Box 1663, Los Alamos, New Mexico 87544 (1)
- Director, Nuclear Science Center, Louisiana State University, Baton Rouge, Louisiana 70803 (2)
- Lovelace Foundation for Medical Education and Research, Document Library, 5200 Gibson Blvd., S. E., Albuquerque, New Mexico 87108 (1)
- Dr. Ross A. McFarland, Guggenheim Professor of Aerospace Health and Safety, Harvard School of Public Health, 665 Huntington Avenue, Boston, Massachusetts 02115 (1)
- Dr. J. I. Marcum, Rand Corporation, 1700 Main Street, Santa Monica, California 90401 (1)
- Massachusetts Institute of Technology, M. I. T. Libraries, Technical Reports, Room 14 E-210, Cambridge, Massachusetts 02139 (1)

OTHER (continued)

- Dr. Charles W. Mays, Physics Group Leader, Radiobiology Division, University of Utah, Salt Lake City, Utah 84112 (1)
- Ohio State University, Nuclear Reactor Laboratory, 1298 Kinnear Road, Columbus, Ohio 43212 (1)
- Dr. Harvey M. Patt, Laboratory of Radiobiology, University of California, San Francisco Medical Center, San Francisco, California 94122 (1)
- Purdue University, Nuclear Engineering Library, Lafayette, Indiana 47907 (1)
- Dr. S. M. Reichard, Director, Division of Radiobiology, Medical College of Georgia, Augusta, Georgia 30902 (1)
- University of Rochester, Atomic Energy Project Library, P. O. Box 287, Station 3, Rochester, New York 14620 (1)
- Dr. H. H. Rossi, 630 West 168th Street, New York, N. Y. 10032 (1)
- Dr. Eugene L. Saenger, Director, Radioisotope Laboratory, Cincinnati General Hospital, Cincinnati, Ohio 45229 (1)
- Sandia Corporation Library, P. O. Box 5800, Albuquerque, New Mexico 87115 (1)
- Scientific Committee on the Effects of Atomic Radiation, ATTN: Library, United Nations Room 3267, United Nations Plaza, New York, N. Y. 10017 (1)
- Scope Publications, Franklin Station, P. O. Box 7407, Washington, D. C. 20004 (1)
- Texas A. and M. University, Radiation Biology Laboratory, Texas Engineering Experiment Station, College Station, Texas 77840 (2)
- Texas Nuclear Corporation, ATTN: Director of Research, Box 9267 Allandale Station, Austin, Texas 78756 (1)
- Western Reserve University, Department of Radiology, Division of Radiation Biology, Cleveland, Ohio 44106 (1)
- Mr. Lionel Zamore, 601 Brightwater Court, Brooklyn, New York 11235 (1)

FOREIGN

- International Atomic Energy Agency, Kärntnerring 11, Vienna I, 1010, Austria (1)
- European Atomic Energy Community, C. E. E. A., Library, 51 rue Belliard, Brussels 4, Belgium (1)
- Dr. L. G. Lajtha, Paterson Laboratories, Christie Hospital and Holt Radium Institute, Manchester, England (1)
- Dr. L. F. Lamerton, Biophysics Department, Institute of Cancer Research, Surrey Branch, Belmont, Sutton, Surrey, England (1)
- National Lending Library for Science and Technology, Boston Spa, Yorkshire, England (1)
- Directorate of Medical and Health Services, FAF (Federal Armed Forces), Bonn, Ermekeilstrasse 27, West Germany (1)
- Abteilung für Strahlenbiologie im Institut für Biophysik der Universität Bonn, 53 Bonn-Venusberg, Annaberger Weg 15, Federal Republic of Germany (2)
- Prof. Dr. H. Langendorff, Direktor des Radiologischen Instituts der Universität, 78 Freiburg im Breisgau, Albertstrasse 23, Germany (1)
- Priv.-Doz. Dr. O. Messerschmidt, Radiologisches Institut der Universität, 78 Freiburg im Breisgau, Albertstrasse 23, Germany (1)
- Dr. Helmut Mitschrich, Akademie des Sanitäts- und Gesundheitswesens der Bundeswehr, Spezialstab ATV, 8 München, Schwere Reiterstrasse 4, Germany (2)
- Prof. Dr. F. Wachsmann, Gesellschaft für Strahlenforschung m.b.H., 8042 Neuherberg bei München, Institut für Strahlenschutz, Ingolstädter Landstrasse 1, München, Germany (1)
- Col. Joachim Emde, Direktor, Spezialstab ATV, ABC- und Selbstschutzschule, 8972 Sonthofen 2/Allgäu, Berghoferstrasse 17, West Germany (1)
- Dr. M. Feldman, Section of Cell Biology, The Weizmann Institute of Science, Rehovoth, Israel (1)
- Dr. G. W. Barendsen, Radiobiological Institute TNO, Rijswijk, Netherlands (1)
- Puerto Rico Nuclear Center, ATTN: Reading Room, College Station, Mayaguez, Puerto Rico 00708 (2)
- Dr. H. Cottier, Pathological Institut der Universität, Bern, Switzerland (1)

UNCLASSIFIED

Security Classification

DOCUMENT CONTROL DATA - R & D

(Security classification of title, body of abstract and indexing annotation must be entered when the overall report is classified)

1. ORIGINATING ACTIVITY (Corporate author) Armed Forces Radiobiology Research Institute Defense Nuclear Agency Bethesda, Maryland 20014		2a. REPORT SECURITY CLASSIFICATION UNCLASSIFIED	
		2b. GROUP N/A	
3. REPORT TITLE THE MEASUREMENT OF CAPILLARY PERMEABILITY CHANGES IN THE IRRADIATED RAT USING A DOUBLE ISOTOPE TECHNIQUE			
4. DESCRIPTIVE NOTES (Type of report and inclusive dates)			
5. AUTHOR(S) (First name, middle initial, last name) M. M. Graham			
6. REPORT DATE September 1971		7a. TOTAL NO. OF PAGES 20	7b. NO. OF REFS 16
8a. CONTRACT OR GRANT NO.		9a. ORIGINATOR'S REPORT NUMBER(S) AFRRI SR71-12	
b. PROJECT NO. NWER XAXM			
c. Task and Subtask C 903		9b. OTHER REPORT NO(S) (Any other numbers that may be assigned this report)	
d. Work Unit 06			
10. DISTRIBUTION STATEMENT Approved for public release; distribution unlimited			
11. SUPPLEMENTARY NOTES		12. SPONSORING MILITARY ACTIVITY Director Defense Nuclear Agency Washington, D. C. 20305	
13. ABSTRACT Capillary permeability was measured using <sup>131</sup> I albumin and <sup>125</sup> I albumin to assay the movement of albumin out of the bloodstream into the interstitial fluid of small intestine and muscle of the irradiated rat. One hour after 800 rads 30 MeV electron whole-body irradiation, small intestine capillary permeability increased significantly, returned to normal levels in a few hours, and then after 8 hours increased and remained at 65 percent above control levels for several days. Muscle capillary permeability increased within 2 hours after irradiation and remained elevated for several days. Cyproheptadine, an antiserotonin-antihistamine, completely blocked a 45 percent increase in small intestine capillary permeability seen immediately after 10,000 rads <sup>60</sup> Co irradiation but had little effect at 48 hours after irradiation.			

14. KEY WORDS	LINK A		LINK B		LINK C	
	ROLE	WT	ROLE	WT	ROLE	WT
microcirculation isotope technique radiation rat						