

*Last Copy
use to make copies*

AD _____

USAARL REPORT NO. 71-19

ENGINEERING TEST OF LIGHTWEIGHT UNDERWEAR OF THE
WINTER FLIGHT CLOTHING SYSTEM: THERMAL PROTECTION

BY

Francis S. Knox, III
George R. McCahan, Jr.
Thomas L. Wachtel
Walter P. Trevethan
Andrew S. Martin
David R. DuBois
George M. Keiser

June 1971

U. S. ARMY AEROMEDICAL RESEARCH LABORATORY

Fort Rucker, Alabama 36360



| DOCUMENT CONTROL DATA - R & D | | |
|--|--|---|
| <i>(Security classification of title, body of abstract and indexing annotation must be entered when the overall report is classified)</i> | | |
| 1. ORIGINATING ACTIVITY (Corporate author) US Army Aeromedical Research Laboratory Fort Rucker, Alabama | | 2a. REPORT SECURITY CLASSIFICATION Unclassified |
| | | 2b. GROUP |
| 3. REPORT TITLE Engineering Test of Lightweight Underwear of the Winter Flight Clothing System: Thermal Protection | | |
| 4. DESCRIPTIVE NOTES (Type of report and inclusive dates) Paper for publication | | |
| 5. AUTHOR(S) (First name, middle initial, last name) Francis S. Knox, III Walter P. Trevethan George M. Keiser George R. McCahan, Jr. Andrew S. Martin Thomas L. Wachtel David R. DuBois | | |
| 6. REPORT DATE June 1971 | 7a. TOTAL NO. OF PAGES 33 | 7b. NO. OF REFS 12 |
| 8a. CONTRACT OR GRANT NO. b. PROJECT NO. 3AO 6211 OA 819 c. d. | 9a. ORIGINATOR'S REPORT NUMBER(S) 71-19 | |
| 9b. OTHER REPORT NO(S) (Any other numbers that may be assigned this report) | | |
| 10. DISTRIBUTION STATEMENT This document has been approved for public release and sale; its distribution is unlimited | | |
| 11. SUPPLEMENTARY NOTES | | 12. SPONSORING MILITARY ACTIVITY US Army Medical R&D Command Washington, D.C. 20314 |
| 13. ABSTRACT This report describes the use of a bioassay technique to evaluate the fire resistant and thermal protection capabilities of the lightweight underwear of the Army winter flight clothing system. Samples of fabrics under consideration for inclusion in the Army winter flight clothing system were mounted on a template and held in contact with the side of a pig. Thus protected, the pig was exposed to a flame source calibrated to simulate a well developed JP-4 fire. Exposure times of 1.75, 3.50, and 7.0 seconds were used. Evaluation of resultant skin burns shows that none of the fabric systems, as evaluated, meet the essential requirement of 10 seconds protection. Single-layered fabric (Nomex shell fabric) offers slight protection and double-layered fabric systems (Nomex outer shell with either Nomex underwear or 50% cotton/50% wool underwear) offer more than three times the protection of single layers, but still fail to provide 10 seconds of protection. The 50% cotton/50% wool underwear offers equal or better protection than experimental Nomex underwear worn under standard Nomex outer shell. Washing does not affect thermal protection. The data further indicate that the method using pigs provides a very consistent and meaningful way of evaluating thermal protective fabrics. | | |

Unclassified

Security Classification

| 14. KEY WORDS | LINK A | | LINK B | | LINK C | |
|---|--------|----|--------|----|--------|----|
| | ROLE | WT | ROLE | WT | ROLE | WT |
| Burns Thermal Protective Clothing Test Methods Skin Life Support Equipment Aviation Safety | | | | | | |

Unclassified

Security Classification

NOTICE

Qualified requesters may obtain copies from the Defense Documentation Center (DDC), Cameron Station, Alexandria, Virginia. Orders will expedited if placed through the librarian or other person designated to request documents from DDC (formerly ASTIA).

Change of Address

Organizations receiving reports from the US Army Aeromedical Research Laboratory on automatic mailing lists should confirm correct address when corresponding about laboratory reports.

Disposition

This document has been approved for public release and sale; its distribution is unlimited.

Disclaimer

The findings in this report are not to be construed as an official Department of the Army position unless so designated by other authorized documents.

In conducting this research, the investigators adhered to the "Guide for Laboratory Animals Facilities and Care" prepared by the committee on the Guide for Laboratory Animals Facilities and Care, National Academy of Sciences, National Research Council. Humane procedures were utilized throughout and a graduate veterinarian was in constant attendance to perform all surgical procedures and to ensure that all animals were fully anesthetized and insensitive to pain.

ABSTRACT

This report describes the use of a bioassay technique to evaluate the fire resistant and thermal protection capabilities of the lightweight underwear of the Army winter flight clothing system. Samples of fabrics under consideration for inclusion in the Army winter flight clothing system were mounted on a template and held in contact with the side of a pig. Thus protected, the pig was exposed to a flame source calibrated to simulate a well developed JP-4 fire. Exposure times of 1.75, 3.50, and 7.0 seconds were used.

Evaluation of resultant skin burns shows that none of the fabric systems, as evaluated, meet the essential requirement of 10 seconds protection. Single-layered fabric (Nomex shell fabric) offers slight protection and double-layered fabric systems (Nomex outer shell with either Nomex underwear or 50% cotton/50% wool underwear) offer more than three times the protection of single layers, but still fail to provide 10 seconds of protection. The 50% cotton/50% wool underwear offers equal or better protection than experimental Nomex underwear worn under standard Nomex outer shell. Washing does not affect thermal protection. The data further indicate that the method using pigs provides a very consistent and meaningful way of evaluating thermal protective fabrics.

APPROVED:



ROBERT W. BAILEY
COLONEL, MS
Commanding

TABLE OF CONTENTS

| | |
|-----------------------|----|
| INTRODUCTION | 1 |
| METHODS AND MATERIALS | 2 |
| RESULTS | 9 |
| DISCUSSION | 24 |
| CONCLUSIONS | 31 |
| REFERENCES | 32 |
| LIST OF EQUIPMENT | 33 |

LIST OF TABLES AND FIGURES

| | | <u>Page</u> |
|-----------|--|-------------|
| FIGURE 1 | Experimental Apparatus | 3 |
| FIGURE 2 | Template Showing Size, Location and Code Number for Each Test Site | 4 |
| FIGURE 3 | Block Diagram of Data Acquisition System | 8 |
| TABLE I | Flame Gun Calibration Data | 9 |
| TABLE II | Grading System for Gross Burn Evaluation | 10 |
| FIGURE 4 | Average Degree of Burn (Gross Evaluation) vs Exposure Time | 12 |
| FIGURE 5 | Average Degree of Burn (Microscopic Evaluation) vs Exposure Time | 13 |
| FIGURE 6 | Time-Temperature Relationships for a 1.75 Second Burn | 14 |
| FIGURE 7 | Time-Temperature Relationships for a 3.5 Second Burn | 15 |
| FIGURE 8 | Time-Temperature Relationships for a 7.0 Second Burn | 16 |
| TABLE III | Degree of Burn Associated with Time- Temperature Relationships in Figure 6, 7, and 8 | 17 |
| FIGURE 9 | Porcine Skin and Wooden Template After a 1.75 Second Exposure | 18-19 |
| FIGURE 10 | Porcine Skin and Wooden Template After a 3.5 Second Exposure | 20-21 |
| FIGURE 11 | Porcine Skin and Wooden Template After a 7.0 Second Exposure | 22-23 |

LIST OF TABLES AND FIGURES

| | | <u>Page</u> |
|-----------|--|-------------|
| TABLE IV | Degree of Burn (Gross) Compared for Different Protective Systems | 26 |
| TABLE V | Degree of Burn (Microscopic) Com- pared for Different Protective Systems | 27 |
| TABLE VI | Time to Reach Severe Second Degree Burn | 30 |
| TABLE VII | Mortality | 30 |

ENGINEERING TEST OF LIGHTWEIGHT UNDERWEAR OF THE WINTER FLIGHT CLOTHING SYSTEM: THERMAL PROTECTION

INTRODUCTION

During fiscal year 1969, there were 133 noncombat aircraft accidents involving UH-1 Army helicopters in which 167 individuals received major injuries and 234 individuals died. Twelve of the 167 major injuries and 64 of the 234 fatalities were due to burns. The minimum total cost of these injuries and deaths due to burns is \$2,730,763.(1,2) Aside from purely humanitarian considerations it is evident that the cost of replacing aircrewmembers incapacitated or killed in post crash fires is of major proportions. Currently flight clothing systems can be designed to provide some thermal protection; however, they may not provide adequate thermal protection.

Our concept of adequate thermal protection is defined as: that level of protection sufficient to allow an uninjured aircrewman to egress while receiving minimal (20% body area) second and third degree burns from a downed aircraft surrounded by a fully developed fuel fire. This level of protection was chosen for purposes of discussion because it would result in at least 90% survival of aviators between the ages 20 and 50 who received prompt care at a major burn center.(3) To date it has not been possible to define, precisely, escape time from crashed and burning helicopters. It is, therefore, difficult to set an essential level of thermal protection. In 1966, 10 seconds of protection was considered essential.(4) It is against this standard that proposed clothing systems must be judged.

The following experiment was designed in an effort to control the thermal source and to quantify, better, the degree of burn protection provided by candidate thermal protective flight clothing materials. Samples of fabric under consideration for inclusion in the Army winter flight clothing system were mounted on a template and held in contact with the side of a pig. Thus protected, the pig was exposed to a calibrated flame source for various periods of time. Macroscopic (gross) and microscopic (micro) evaluation of tissue damage under the fabric samples indicated the degree of protection afforded by each.

This method was used to test the relative merits of experimental underwear (Nomex) and 50% cotton/50% wool long underwear when worn with the single-layered, U.S. Army standard A flight suit.

METHODS AND MATERIALS

Animals

Domestic, white, male and female pigs, weighing an average of 46 kg (38.6 to 56.8 kg) were locally procured quarantined, and verified to be healthy and free of internal parasites prior to use in this study. Pigs were chosen because their skin more closely resembles human skin than any other commonly used or available laboratory animal.(5) During the quarantine period the pigs were kept in the shade to prevent sunburn. The hair was closely clipped with a #40 clipper head at least two days prior to the study. Several hours prior to an experiment the test area was washed with running water and carefully dried.

Anesthesia

All pigs were premedicated with 100 mg Sernylan (phenylidone hydrochloride - Parke-Davis) and 50 mg Thorazine (chlorpromazine hydrochloride - Pitman-Moore) (both in the same syringe and administered intramuscularly in the right hip) followed by Penthrane (methoxyflurane - Abbott) anesthesia.* Atropine sulfate (0.8 mg/pig, subcutaneous) was routinely used.

When cutaneous sensation had disappeared (determined by the scratch test), the experimental animal was transported from the vivarium to the test site on a specially constructed transporting device. The experimental animal was maintained in Stage III anesthesia on Penthrane and oxygen except during the actual exposure when a Penthrane nose cone was used. Every possible safety precaution was taken to lessen the potential fire hazard of Penthrane and oxygen.

Fire Wall, Shutter System, Template

After reaching the test site, the transporting device holding the pig was positioned behind a hard asbestos (Transite) fire wall. (Figure 1) This wall protected the pig

*See equipment list for all major items.

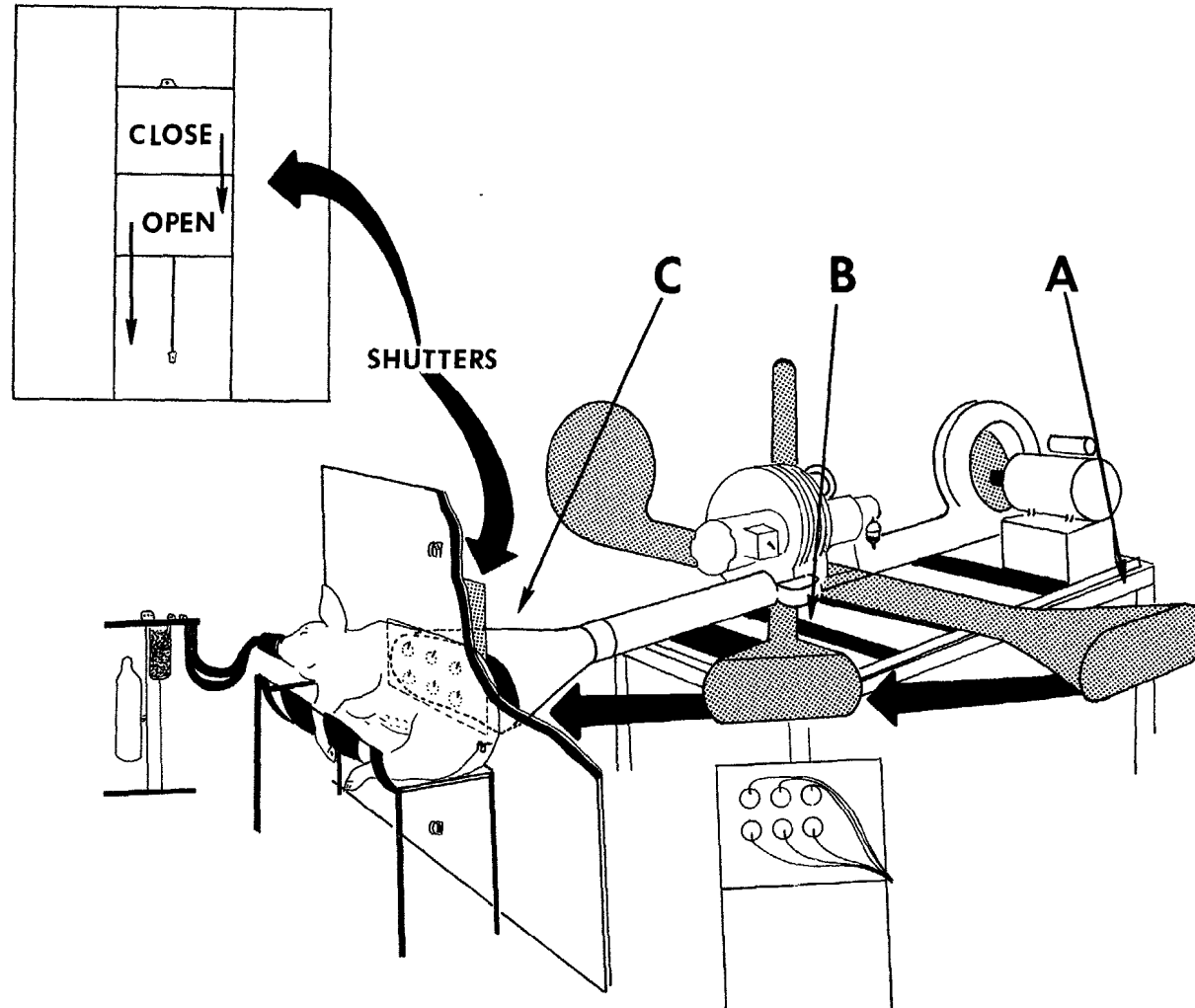

3

FIGURE 1. Experimental apparatus showing the flame gun, thermal barrier with shutter system, pig in transporting device, and thermocouples for steady-state temperature data. Position A is for warm-up, position B is for steady-state flame temperature determinations, and C is the position of the flame gun during an experiment.

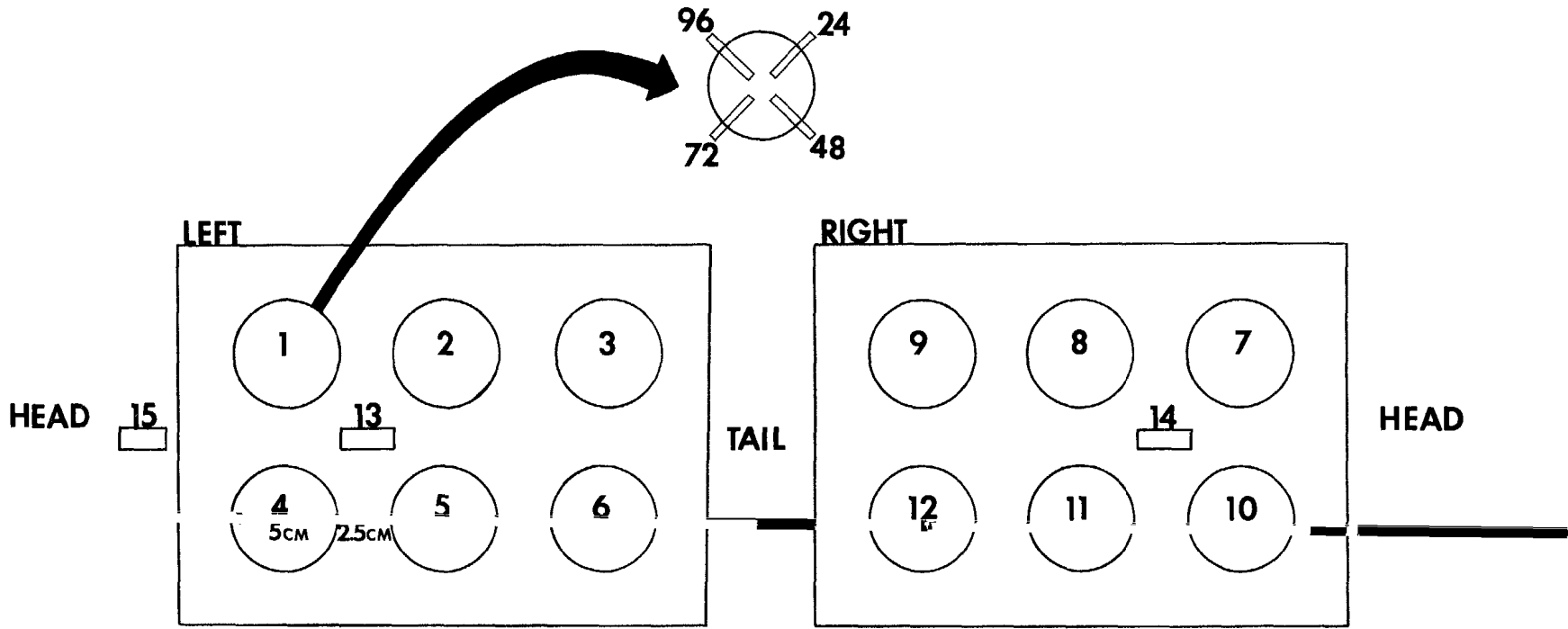

FIGURE 2. Template showing size, location, and code number for each test site. The insert shows the orientation of the incisional biopsies made at each site.

and contained a rectangular aperture through which flame could pass. Passage of the flame was controlled by a double guillotine shutter held in the closed position by pins welded to solenoids. Flame front configuration was changed from a single large rectangle to six 2 inch diameter circles (Figure 2) by positioning a Transite template over the aperture in the fire wall.

To begin an experiment, the left side of the animal was placed against the Transite template. (Figure 1) When properly aligned, a wooden template of exactly the same pattern and alignment was sandwiched between the subject and the Transite. The wooden template insulated the pig from the Transite which acted as a nonflammable thermal conductor. Without this insulation the hot Transite produced skin burns. Each hole in the wooden template was covered by a fabric sample (or left uncovered as a control) and instrumented with an unshielded, 0.005 inch chromel/alumel thermocouple. (Figures 9 and 10) The position of the fabric samples was systematically varied to neutralize any position effect. The proximity of the pig's side to the test site was checked to assure proper alignment without pressure on fabrics or gaps for flame leakage.

Flame Gun

As the pig was being anesthetized the flame gun (modified gun-type - conversion oil burner) was set to deliver 14 ± 0.5 BTU/ft²/sec and was calibrated against water-cooled calorimeters. This level of heat flux simulates a worst credible thermal environment (a well developed JP-4 fire). Such an environment cannot readily be simulated with a standard Meker burner. The kerosene fuel produces a sooty flame whose chemistry simulates a JP-4 fire more closely than natural gas.(6)

After the pig was in position next to the wooden template, the flame gun was ignited at a neutral position (Position A, Figure 1) and allowed to warm up for two minutes until it reached a steady-state. The gun was then moved to impinge on a bank of thermocouples (Position B, Figure 1) until all thermocouples indicated steady-state temperatures. The flame was next moved to the test site (Position C, Figure 1). After one or two seconds, the first solenoid was manually activated opening the shutter and exposing the template. After a predetermined time of 1.75, 3.50, or 7.0 seconds, a second solenoid was automatically activated, thereby closing the shutter. Exposure times were selected by exposing three

pigs to the flame for various times between 1.0 and 5.0 seconds. After selecting 3.5 seconds as the middle time, 1.75, and 7.0 seconds were chosen as one half and twice the middle time, respectively. The time of exposure was recorded on a recording oscillograph and on a calibrated stop clock activated by signals from the solenoids. A manual stop watch provided additional back up. Following the test exposure, the flame was returned to the bank of thermocouples (Position B, Figure 1) for post-burn temperature determinations. When the thermocouples reached a stable state the flame was extinguished.

The pig was moved away from the template shortly after the closing of the second shutter. The burn procedure was then repeated on the right side of the subject using new Transite and new wooden templates. Following the exposures the subject was returned to the vivarium for post anesthetic care, photography, and gross evaluation of burns.

Post Exposure Procedures

Photographs of burned areas were taken immediately post-burn, at two hours, and at 24 hours. The surface appearance of each burn site was drawn by a medical illustrator at 2 and 24 hours post burn. These drawings were used to pinpoint the exact position of a biopsy and to determine the gradations of damage included in each specimen.

Burn Evaluation

The severity of the cutaneous burn lesions was evaluated by two methods. First, the surface appearance was graded immediately, at two hours, and at twenty-four hours by two physicians (a surgeon with experience at a burn center and an internist) and one veterinarian. Second, microscopic tissue damage was assessed by a veterinary pathologist using serial, incisional biopsies taken at 24, 48, 72, and 96 hours with the pig under Penthrane anesthesia. (See Figure 2 for the location of the biopsies.)

The scheme for grading the surface appearance of burns developed by this Laboratory closely parallels the work of the University of Rochester.(7) The mildest surface change (Stage 1) observed was erythema, while the most severe (Stage 6) was carbonization. In between, one could detect four stages:

Stage 2 - a transient purple-circulatory stasis stage

which either progressed to patchy coagulation or regressed to a red burn by 24 hours.

Stage 3 - uniform coagulation.

Stage 4 - steam blebs and destroyed blebs.

Stage 5 - partial carbonization or leathery brown burn.

These six conditions formed a basis for grading tissue damage. (Table II) Furthermore, it was also possible to discern smaller increments of each major gradation and these smaller transitions were recorded as (+) or (-) the major grade. The most severe, least severe, and overall grade were recorded for each burn site. The 24 hour overall grade, a consensus of the three observers, was used in the statistical analyses.

Histopathology

Tissue specimens were fixed in unbuffered 10% formalin and forwarded to the Veterinary Pathology Department of the Naval Aerospace Medical Research Laboratory, Pensacola, Florida, where the following procedures were performed. Fixed tissue specimens were labeled, dehydrated, embedded in hematoxylin and eosin using the method developed at the Armed Forces Institute of Pathology(8) as modified by the Naval Aerospace Medical Research Laboratory.

The completed slides were graded by a veterinary pathologist. From this verbal description of tissue damage and degree of burn it was possible to assign a number which corresponded to the degree of burn. These numbers ranged from 0 to 6.0 in the same way as those used for gross burn evaluation.

Instrumentation

Two types of thermocouple data were recorded during the experiment. The first was the steady-state temperature of the flame impinging upon the template measured at four of six possible locations. The second was the time-temperature history of the pig skin-air interface, protected and unprotected by different clothing ensembles. The block diagram of the two data acquisition systems is shown in Figure 3.

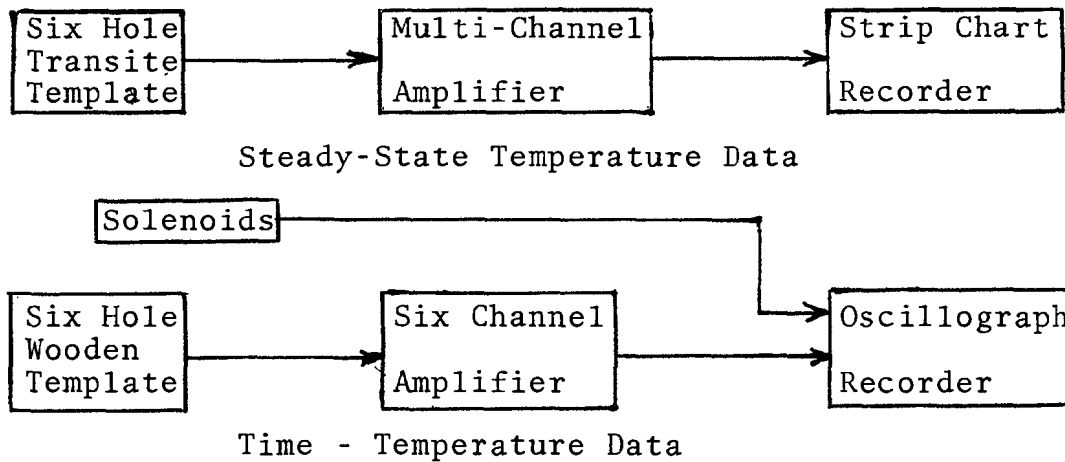

BLOCK DIAGRAM OF DATA ACQUISITION SYSTEM

FIGURE 3

A six hole template was constructed of Transite and instrumented with chromel/alumel thermocouples. (Figure 3) Since transient temperatures and time delays were of no interest here, thick (0.032 inch) and durable thermocouples were used.

The outputs of four of the six thermocouples were amplified and recorded on a strip chart recorder. The complete data train (including 30 ft. of cable) was calibrated using a precision voltage source. This was done to insure that resistive forces in the wire and small nonlinearities in the amplifier and recorder would be accounted for.

The sensors used in the six hole wooden template (Figure 3) were small diameter (0.005 inch) chromel/alumel thermocouples to insure fast response time. They were changed after every burn to eliminate any possibility of their being damaged by the high temperatures. These thermocouples were connected to a six channel amplifier with built-in thermocouple cold junction compensators. The output of the amplifier was connected to a recording oscillograph.

Signals from the solenoids used to operate the shutter system were recorded on the oscillograph directly so that an accurate timing signal would be present on the final oscillograph record. This data acquisition system was calibrated using the same precision voltage source as used previously.

RESULTS

A total of 22 pigs were obtained for use in this study. Of these three were used in a pilot procedure to practice technique and to determine appropriate exposure times. Two others did not meet requirements for standard healthy pigs and were not used. The remaining 17 pigs were distributed among the three experimental groups as follows: 1.75 second exposure, 5 pigs; 3.5 and 7.0 second exposures, 6 pigs each. A power failure occurred during exposure of the left side of one pig (3.5 second group). The resultant exposure was only 2.29 seconds, so the data for this side are not included in the results.

Just prior to each test, the flame gun output was calibrated at each of four template locations (Positions 1,3,4, 6, Figure 2) using water-cooled calorimeters. The mean heat flux + one standard deviation for each position and for all positions combined are presented in Table I.

TABLE I

FLAME GUN CALIBRATION DATA
HEAT FLUX MEAN + STD DEVIATION

| POSITION (Fig. 2) | BTU FT ⁻² .SEC ⁻¹ | CAL·CM ⁻² .SEC ⁻¹ |
|-------------------|---|---|
| 1 | 13.81 _± 0.65 | 3.74 _± 0.18 |
| 3 | 13.47 _± 0.51 | 3.65 _± 0.14 |
| 4 | 14.24 _± 0.51 | 3.86 _± 0.14 |
| 6 | 14.41 _± 0.47 | 3.91 _± 0.13 |

The degree of burn (0-6.0 scale, Table II) experienced by the pigs for each combination of protective fabric and exposure duration is presented in Figure 4. These burn values represent the average of the 24 hour gross evaluations for each experimental group. There is a tendency for burns (Figure 4) to become more severe with increasing exposure duration and decreasing number of protective layers.

To illustrate the effect of washing on the protective performance of given fabric systems, the data for washed and

TABLE II
GRADING SYSTEM FOR GROSS BURN EVALUATION

| <u>LABORATORY GRADE</u> | <u>SURFACE APPEARANCE</u> | <u>ADDITIONAL INFORMATION</u> | <u>DESCRIPTIVE TERM</u> | <u>HUMAN EQUIVALENT</u> |
|-------------------------|---|--|-------------------------|--------------------------|
| 0 | Normal Skin | Normal Skin | Normal Skin | No Burn |
| 1 | Erythema | Painful Pliable Hyperemia No Blisters Skin hot to touch | Red Burn | Epidermal |
| 2 | Patch Coagulation (Mottled Red) | Painful Pliable Cap. Refill Possible No blisters Skin hot to touch | Spotted White Burn | Superficial Intra-dermal |
| 3 | Uniform Coagulation (Pearly White) | Pliable Little Pain + Blister (early) - Blister (early) Skin Temp normal | White Burn | Deep Intra-dermal |
| 4 | Steam Bleb early blebs ruptured blebs ruptured blebs with charring | Blisters Moderately Pliable No Pain Skin Temp normal | Blebbled White Burn | Superficial Sub-dermal |
| 5 | Leathery Brown | Nonpliable Cold, Hard Insensitive Thrombosed Vasculature | Leathery Brown Burn | Deep Subdermal |
| 6 | Carbonization | Hard - Fat or Muscle Burned | Charred Black Burn | Very Deep Sub-dermal |

unwashed fabric systems are plotted separately (Figure 4). The remaining results (Figure 5) will be presented in combined form, ie, washed plus unwashed.

Microscopic evaluation of tissue excised from each burn site revealed the average degree of burn (Figure 5) becomes more severe with increasing exposure and decreasing number of protective layers. These data are similar to those presented in Figure 4 with the exception that at 7.0 seconds the data for all treatment groups tends to cluster about one burn level (4.0).

During each exposure the temperature of the fabric-skin interface was recorded as a function of time. Figures 6,7, and 8 show these time-temperature histories for exposures of 1.75, 3.50, and 7.0 seconds, respectively. These records were chosen because they are particularly clear and illustrate features seen in most other records. By comparing the burn evaluations in Table III with the appropriate time-temperature curve, it becomes apparent that the area under the curve is related to the degree of burn. Apparently the only observations inconsistent with this inference are the microscopic evaluations for Nomex and Nomex/Nomex (7.0 sec). They are reversed (Nomex/Nomex>Nomex) when compared with both the gross evaluations (Nomex>Nomex/Nomex) and the areas under the time-temperature curves. This discrepancy is accounted for, however, because the medical illustrations show the biopsies from these burn sites may not have been typical of the entire site.

Figures 9a - 11c are photographs of burn sites at 24 hours post-burn and the front (flame) and back (pig) sides of the protective fabric systems. These photographs show the fabric condition and tissue destruction which occurred in the experiments from which the time-temperature curves (Figures 6-8) were taken. Note that Nomex shell fabric failure proceeds from the center outward.

Various levels of burn, from 0 to 6.0 are represented in Figures 9a, 10a and 11a. The control or unprotected site is always the most severely burned, while sites protected by Nomex/Standard are the least damaged. Tissue between sites is totally free of damage indicating that the template protected the pig. Each burn is clearly circumscribed with minimal edge effect.

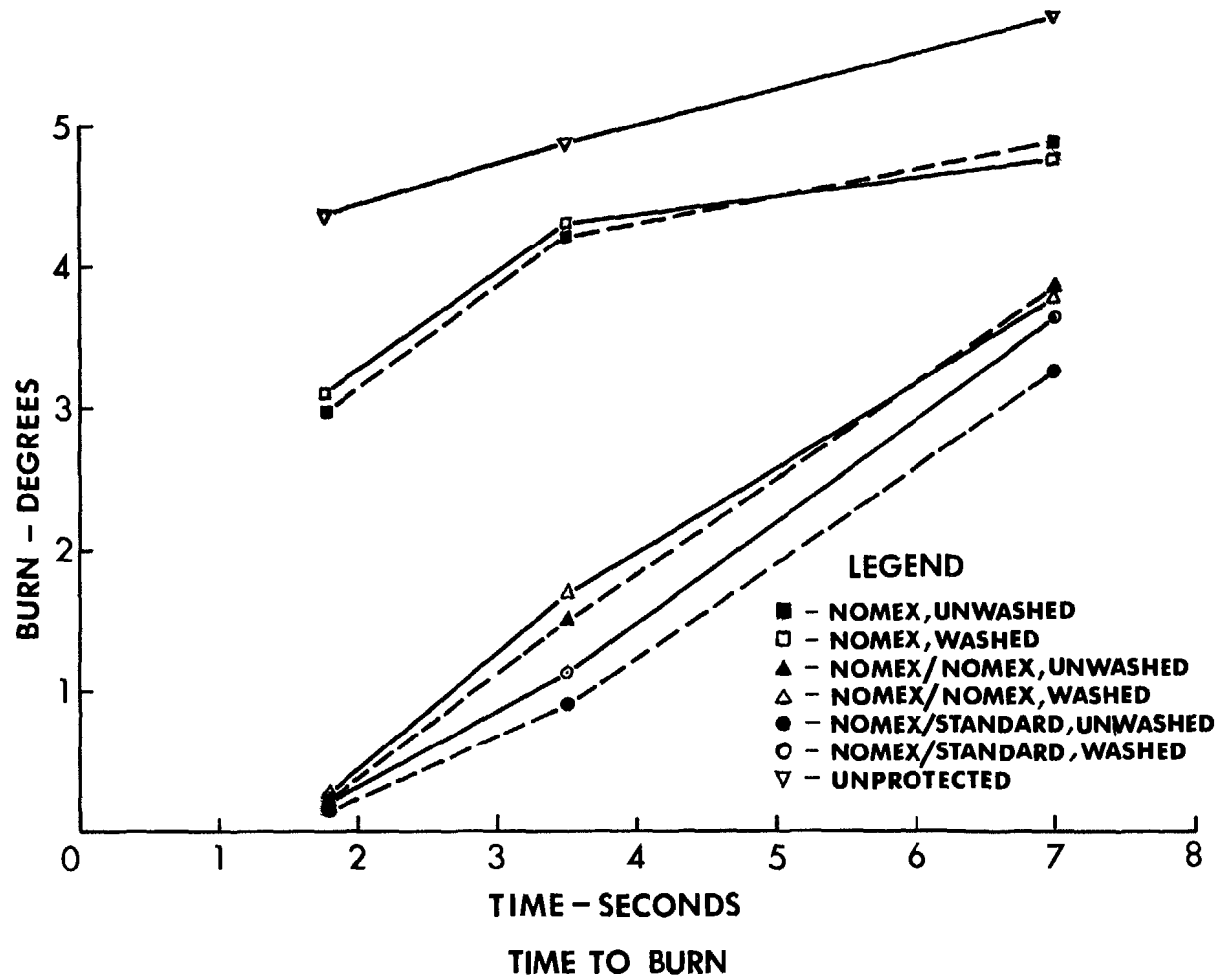

FIGURE 4. Average degree of burn (gross evaluation) vs exposure time.

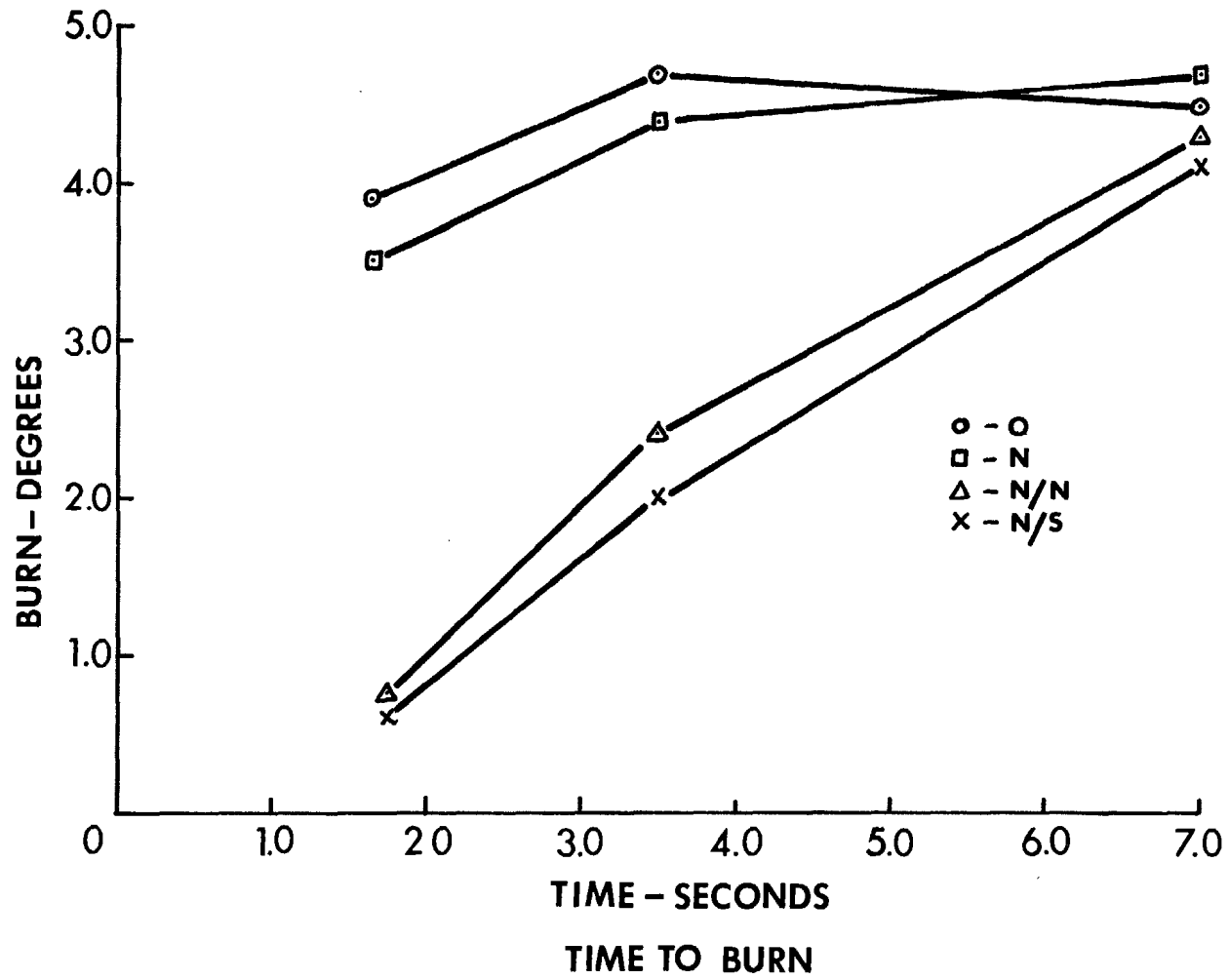
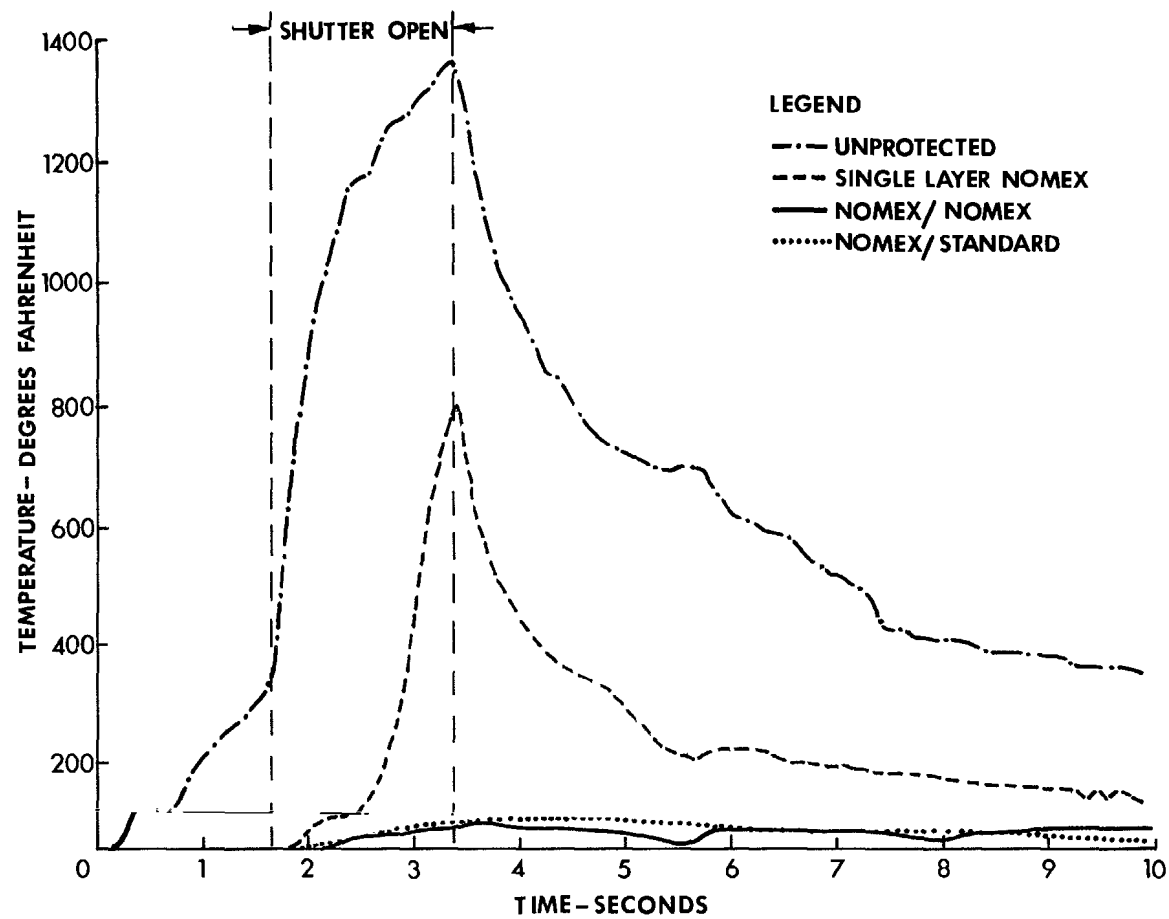

FIGURE 5. Average degree of burn (microscopic evaluation) vs exposure time.



TIME-TEMPERATURE RELATIONSHIPS FOR A 1.75 SECOND BURN

FIGURE 6. These representative temperatures were measured by a thermocouple placed between the fabric and the skin at the center of each test site. The temperature rise which occurred before the shutter opened is due to the heating of the shutter by the flame gun.

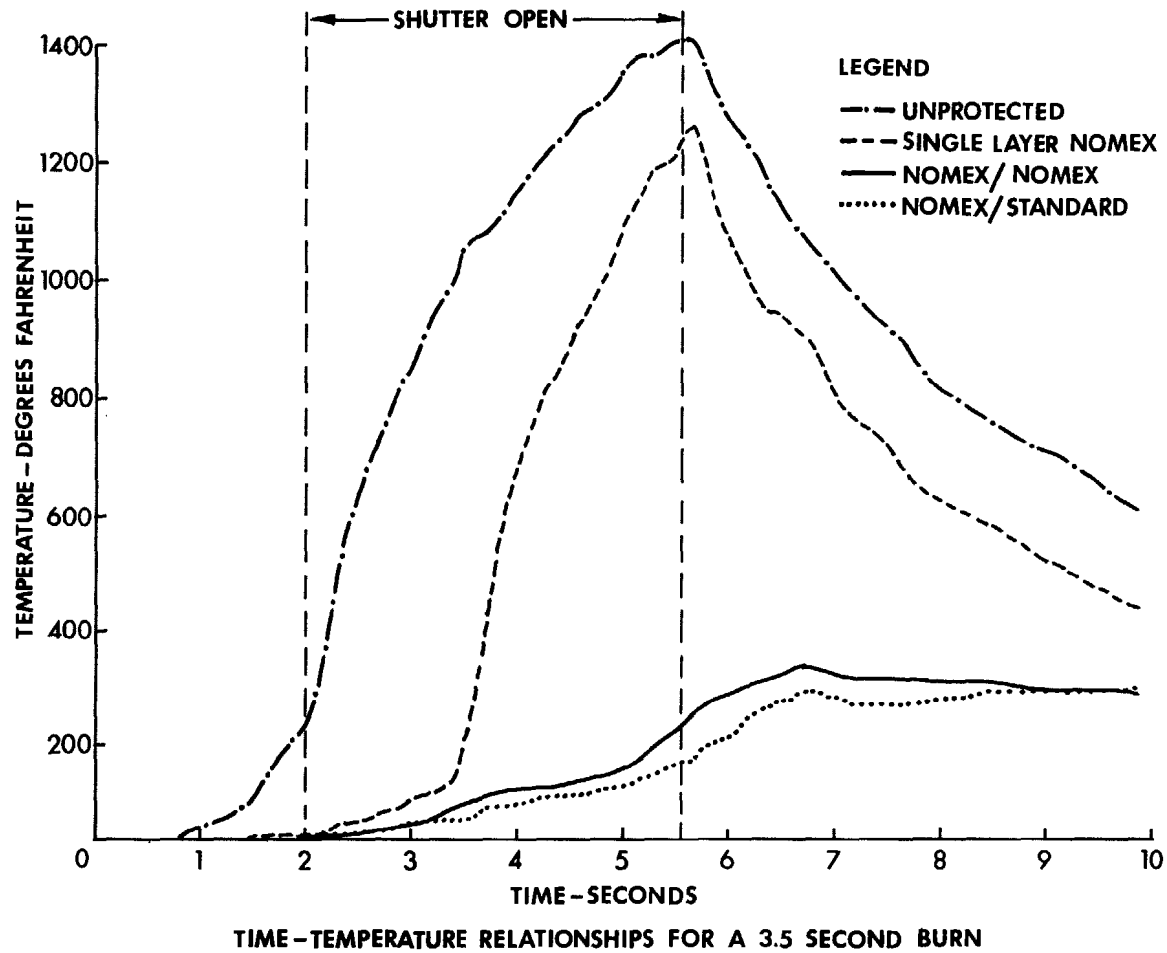

FIGURE 7. These representative temperatures were measured by a thermocouple placed between the fabric and the skin at the center of each test site. The temperature rise which occurred before the shutter opened is due to the heating of the shutter by the flame gun.

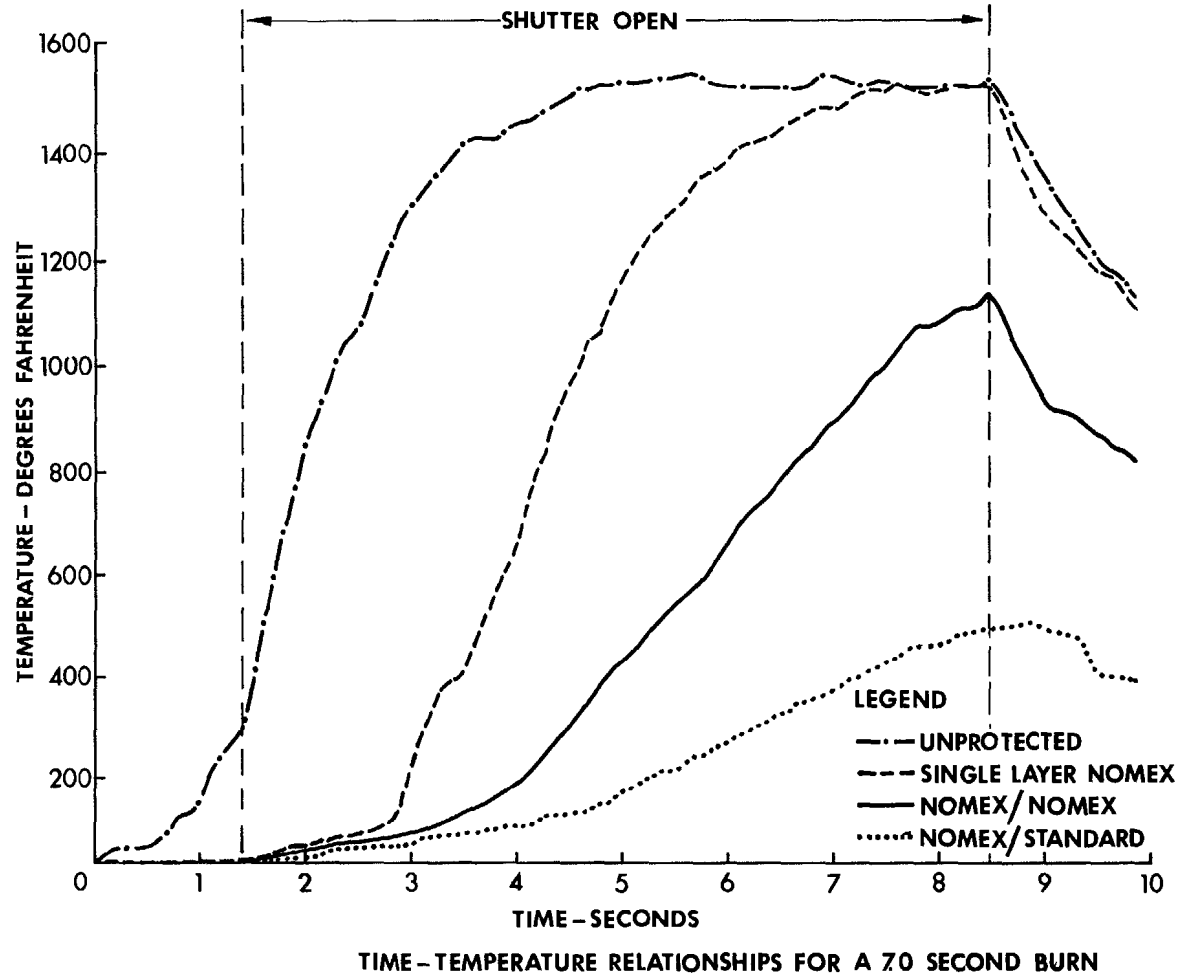

FIGURE 8. These representative temperatures were measured by a thermocouple placed between the fabric and the skin at the center of each test site. The temperature rise which occurred before the shutter opened is due to the heating of the shutter by the flame gun.

TABLE III

DEGREE OF BURN ASSOCIATED WITH TIME-TEMPERATURE
RELATIONSHIPS IN FIGURES 6, 7, 8

| FABRIC | 1.75 SEC | | 3.5 SEC | | 7.0 SEC | |
|----------------|--------------|--------------|--------------|--------------|--------------|--------------|
| | <u>GROSS</u> | <u>MICRO</u> | <u>GROSS</u> | <u>MICRO</u> | <u>GROSS</u> | <u>MICRO</u> |
| Unprotected | 4.0 | 3.7 | 5.0 | 4.3 | 6.0 | 5.3 |
| Nomex | 2.7 | 3.3 | 4.0 | 4.0 | 5.0 | 4.7 |
| Nomex/Nomex | 0 | 0 | 1.0 | 2.7 | 4.3 | 5.0 |
| Nomex/Standard | 0 | 0 | 0.7 | 2.3 | 3.0 | 3.7 |

The following nine photographs show skin burns and damaged fabric samples. To assist the reader in viewing these figures, the following explanation is presented. Only the fabrics and skin areas located in the upper center, upper right, lower center, and lower right positions are the subject of this report. The data in the upper and lower, left positions belong to another study conducted concurrently with that reported here. The white objects protruding into the center of each template hole are the 0.005 inch chromel/alumel thermocouples used to record the temperature at the fabric-skin interface. The figures are arranged so the burn in the lower right position of Figure 9a corresponds to the fabric samples at the lower right position in Figures 9b and 9c.

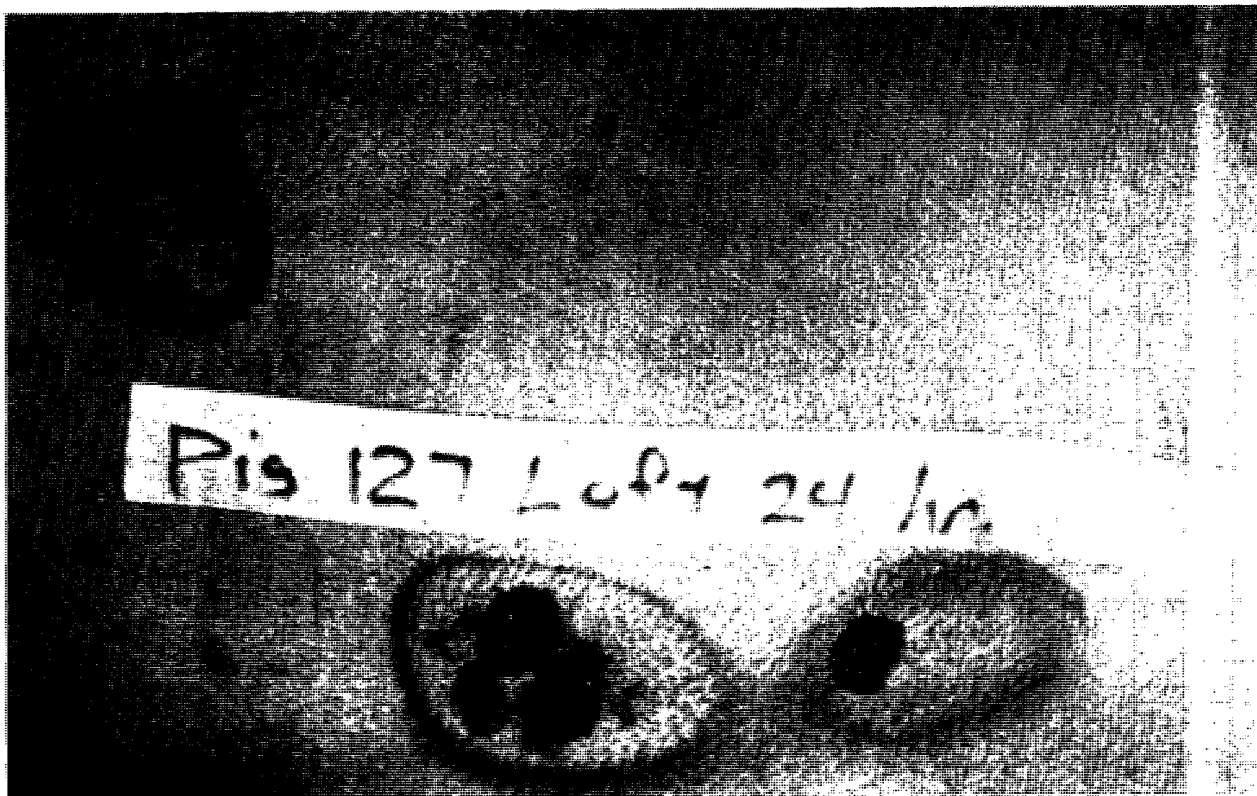

FIGURE 9a

FIGURE 9a. Porcine skin after a 1.75 second exposure.

FIGURE 9b. Front of wooden template after a 1.75 second exposure.

FIGURE 9c. Rear of wooden template after a 1.75 second exposure.

The upper center position was covered with Nomex over Nomex underwear and received no noticeable burn (0 level, gross evaluation).

The upper right position was covered with Nomex over Nomex underwear and received no noticeable burn (0 level, gross evaluation).

The lower center position was unprotected and received a 4.0 level burn (gross evaluation).

The lower right position was covered with a single layer of Nomex and received a 2.7 level burn (gross evaluation).

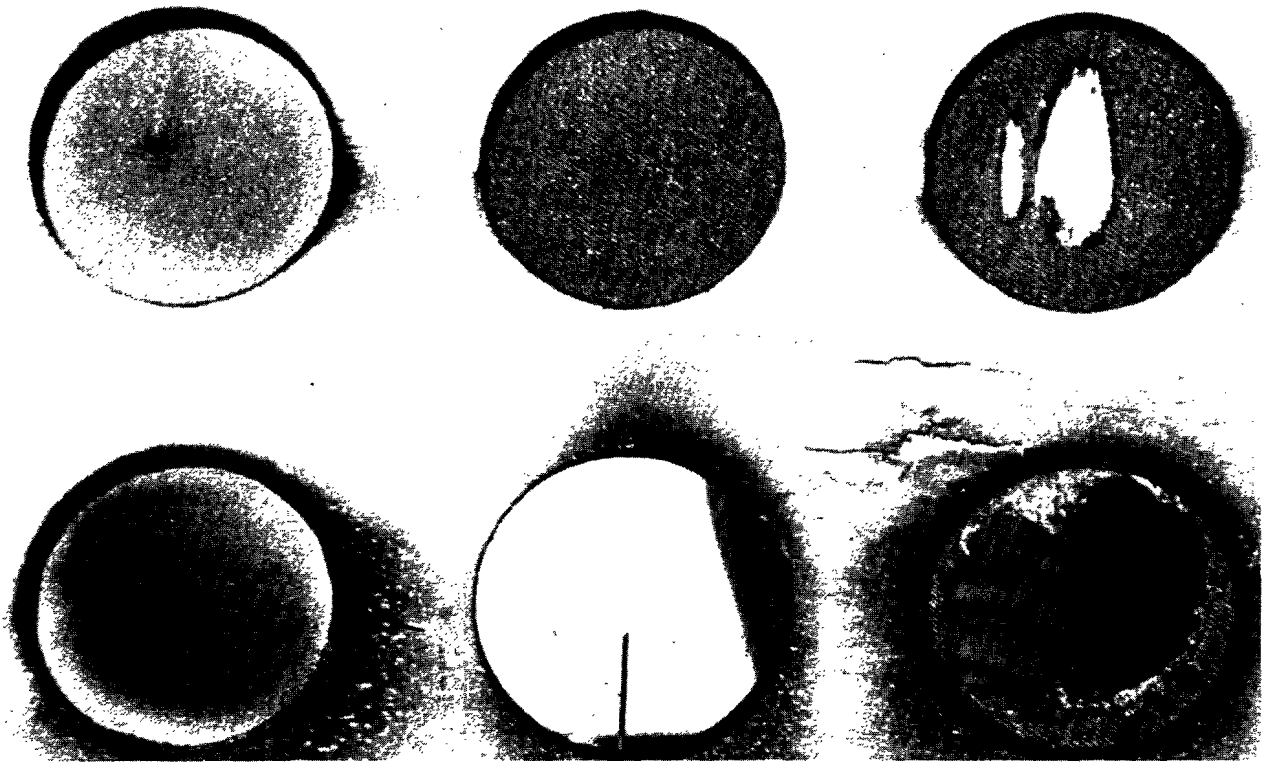

FIGURE 9b

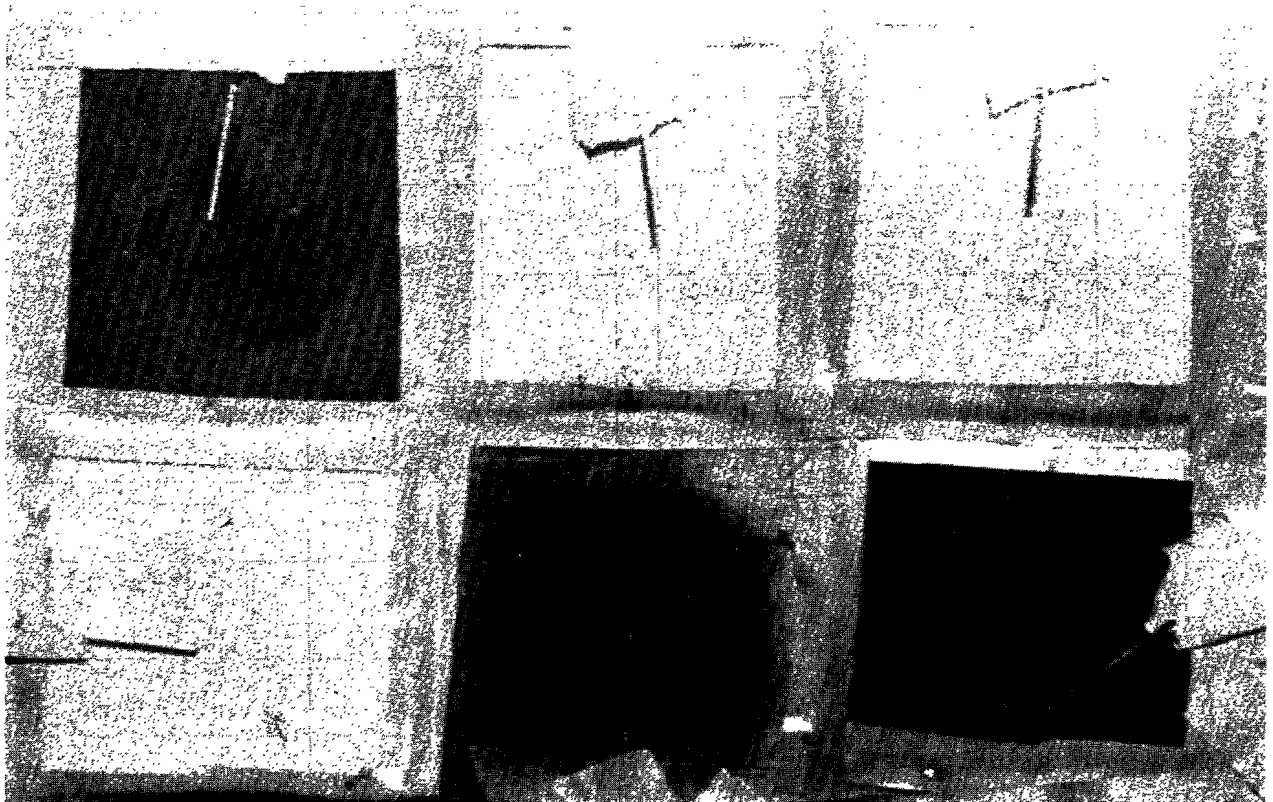

FIGURE 9c

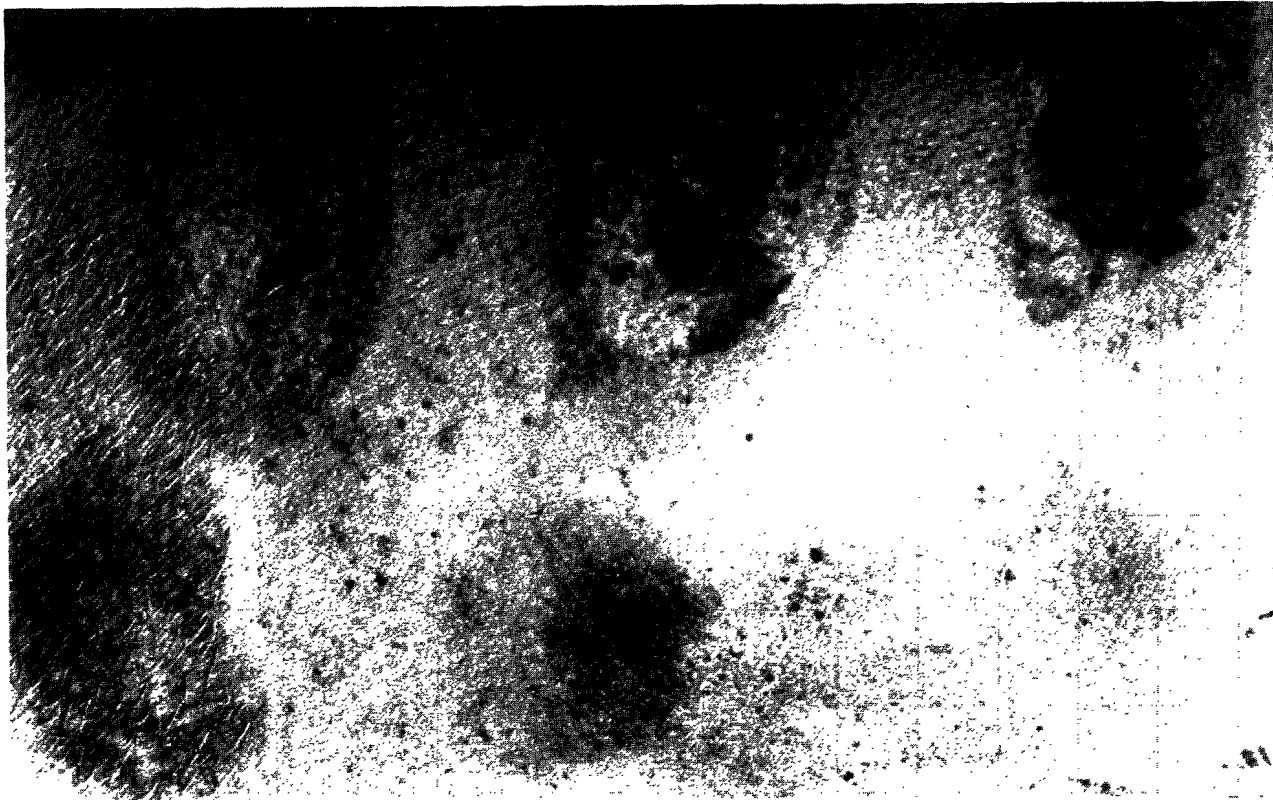

FIGURE 10a

FIGURE 10a. Porcine skin after a 3.5 second exposure.

FIGURE 10b. Front of wooden template after a 3.5 second exposure.

FIGURE 10c. Rear of wooden template after a 3.5 second exposure.

The upper center position was covered with a single layer of washed Nomex and received a 4.0 level burn (gross evaluation).

The upper right position was unprotected and received a 5.0 level burn (gross evaluation).

The lower center position was covered with Nomex over washed Nomex underwear and received a 1.0 level burn (gross evaluation).

The lower right position was covered with Nomex over washed standard underwear and received a 0.7 level burn (gross evaluation).

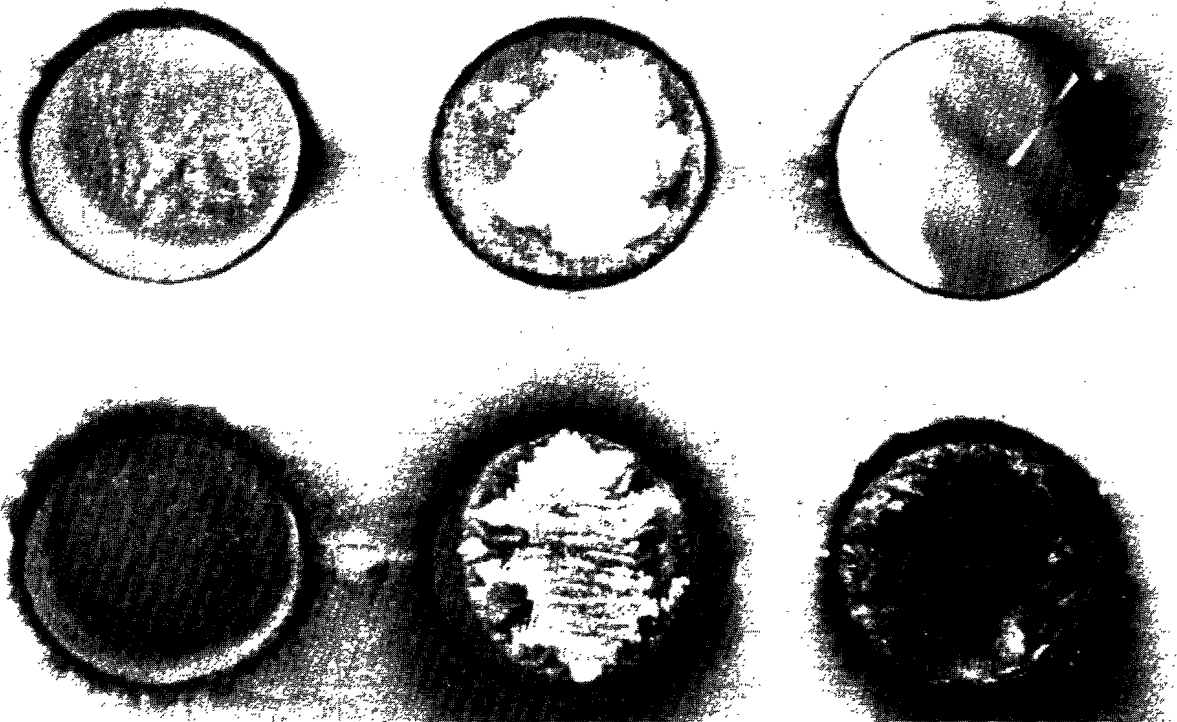

FIGURE 10b

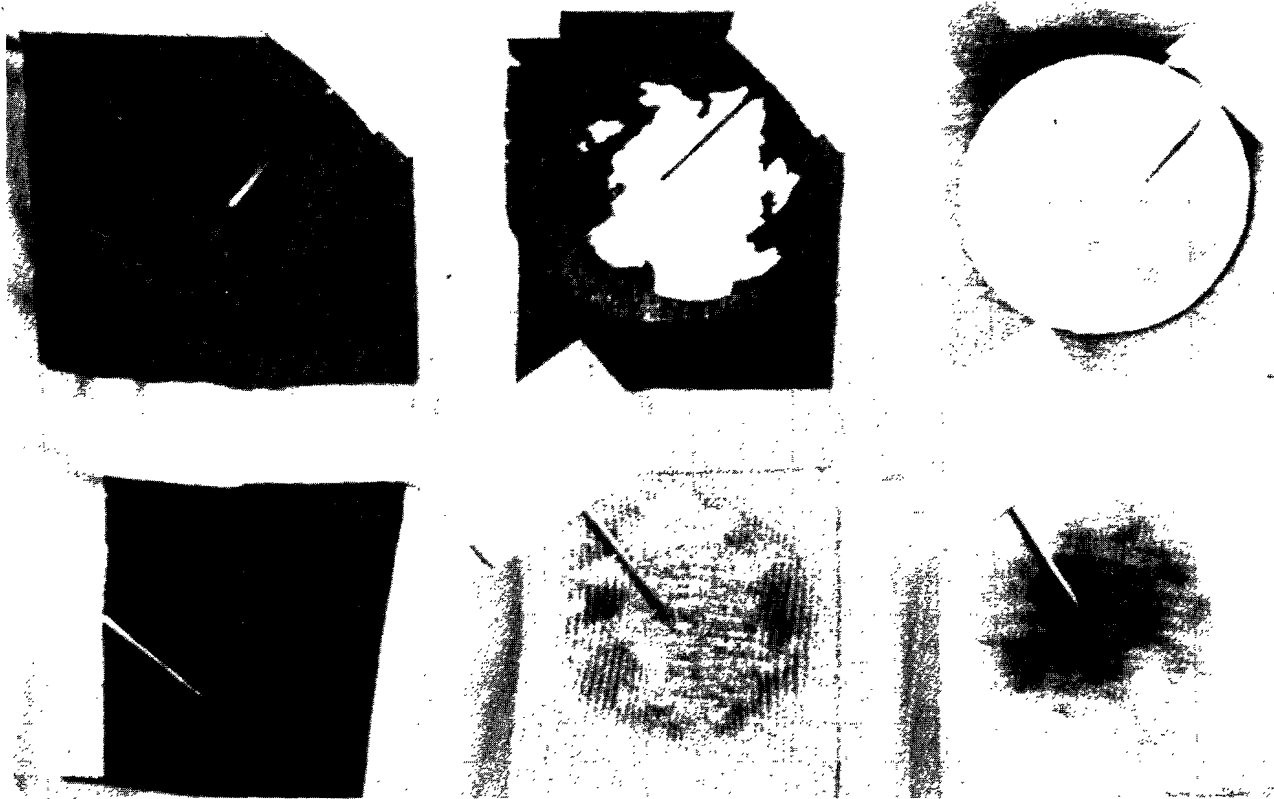

FIGURE 10c

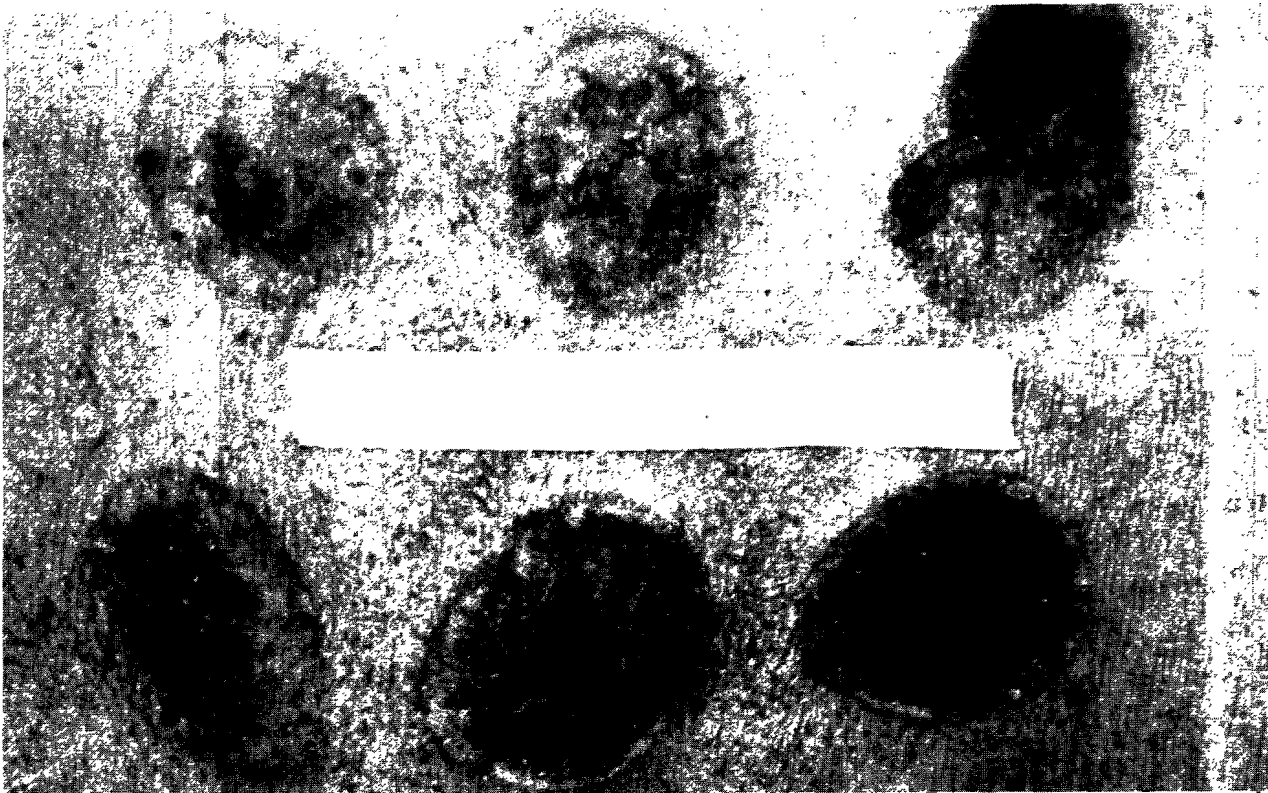

FIGURE 11a

FIGURE 11a. Porcine skin after a 7.0 second exposure.

FIGURE 11b. Front of wooden template after a 7.0 second exposure.

FIGURE 11c. Rear of wooden template after a 7.0 second exposure.

The upper center position was covered with Nomex over washed Nomex underwear and received a 4.3 level burn (gross evaluation).

The upper right position was covered with Nomex over washed standard underwear and received a 3.0 level burn (gross evaluation).

The lower center position was covered with a single layer of washed Nomex and received a 5.0 level burn (gross evaluation).

The lower right position was unprotected and received a 6.0 level burn (gross evaluation).

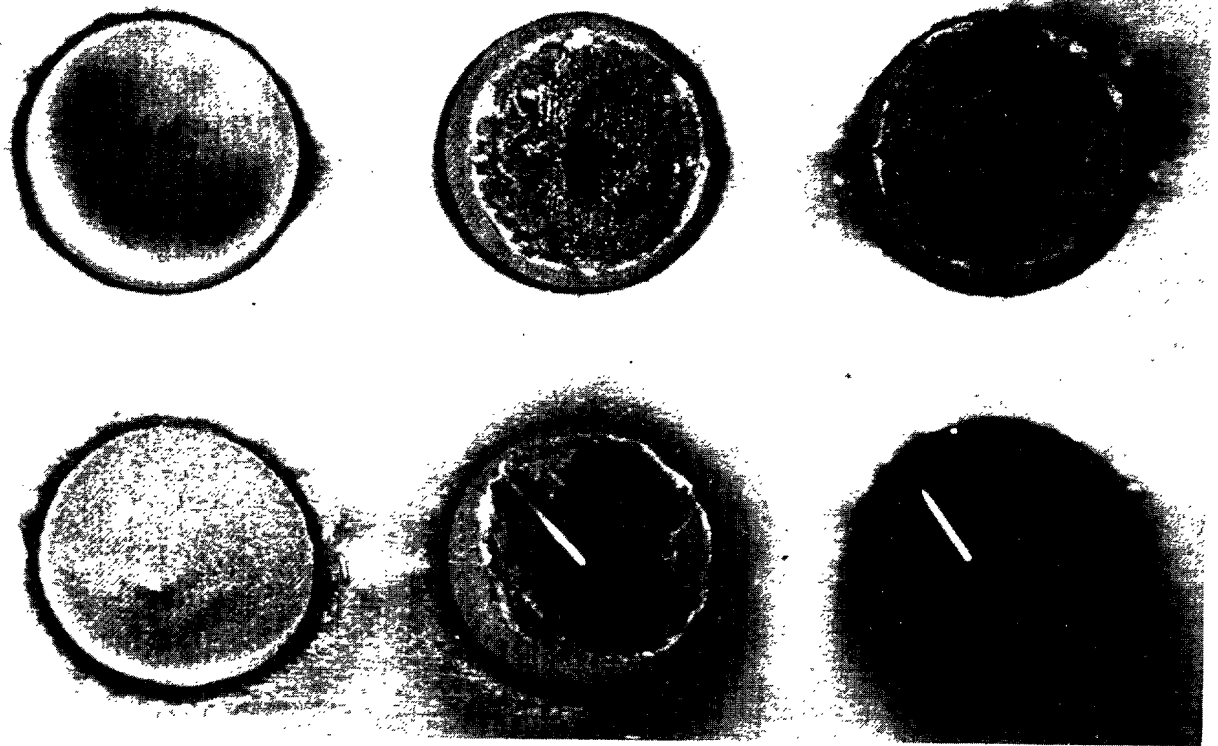

FIGURE 11b

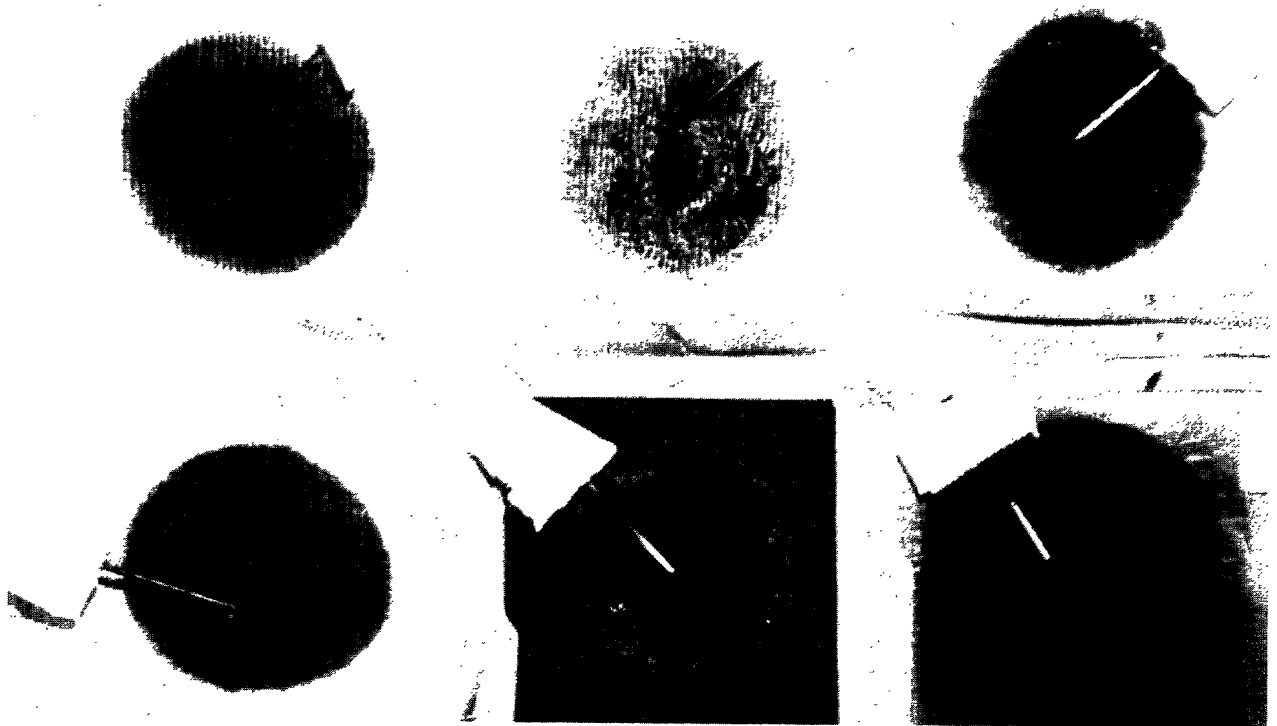

FIGURE 11c

DISCUSSION

The initial surface alteration on exposure to flame was a pink unstable lesion characterized by hyperemia. This disappeared by the 24 hour evaluation. A slightly more severe stage was a stable erythema or red burn. The next level of severity was a purple circulostasic state that generally receded to an erythematous burn (1+), or occasionally proceeded to the spotty red and greenish-yellow (in approximately equal amounts) patterns of patchy coagulation. The off-white (different from the usual white pig skin) color of uniform coagulation followed. The early appearance of "crumpled tissue paper" steam blebs marked the end of the white burn (3+). Steam blebs were gray, delicate, and broad-based with more severe burns beginning to show central or multifocal charred epithelium and hair stubble (4+). As the severity progressed the bleb was consumed, and charring spread peripherally until the entire test site became charred and cadaveric. Change in the pliability was only moderately noted even at the 24 hour evaluation. Any hair stubble could be easily removed. Some burn lesions appeared to be even more severely carbonized and were nonpliable in the immediate post-burn evaluation (6.0). In these no hair was present to be removed.

Although the less severe burns tended to improve slightly and the more severe burns tended to progress to a slightly worse grade from that observed in the immediate post-burn evaluation, all burn test sites failed to deviate after 24 hours thus making the surface appearance during the serial biopsies essentially unchanged.

The 5 cm test sites were sharply demarcated with very little edge effect at these short exposures to high intensity flame. They were circumscribed by a red ring (red burn) of not more than 2 mm in width. When the fabric or fabric combinations failed, several grades of burn could be identified within the same test site mimicking the fabric failure areas. The ceramic covered thermocouples offered some protection from the more severe burns; but because of their ability to retain heat, they frequently produced erythema and patchy or uniform coagulation in the least severe burns.

Microscopic examination of the skin specimens revealed damage ranging from none, in control biopsies, to almost fourth degree burn in unprotected 7.0 second exposures. The description of general pathology and classification of the

burns were based on the works of Anderson(9) and Jobb and Kennedy.(10) According to these authors, burns are generally classified according to the depth of injury. As heat is absorbed, the epidermis is the first and most severely injured.

First degree burns are manifested by erythema and edema with no morphological sign of injury to the epithelial cells.

In second degree burns, the epidermis is destroyed without significant irreversible damage to the dermis. Vascular changes are prominent, and vesicles form in and beneath the epidermis. These may contain serum, cellular debris and leukocytes, and may suppurate or rupture quickly. The cytoplasm of the epithelial cells is coagulated and nuclei shrunken or ruptured.

Third degree burns show sufficient damage to the dermis, with coagulation and destruction of part of the connective tissue, blood vessels, and adnexa, to interfere with epithelial regeneration. Heat of sufficient intensity or duration to penetrate this deep usually desiccates and chars the outer epidermis. An amorphous agglomeration is produced by coagulation of the epidermis and dermis.

Fourth degree burns are similar in character to third degree, but penetrate below the dermis and through the subcutaneous fascia. The preceding criteria were used to judge the degree of burn to the skin specimens. When third degree burns were present, the depth and extent of injury to the dermis was determined. The numerical grades developed from these descriptive criteria were used to plot the data (Figure 5) and for statistical analyses.

Understanding that there is an apparent assymetry to the flame front (Table I), there are two questions that must be answered. (1) Are any of the positions significantly hotter than the others? (2) If so, then are the burns produced at the hotter locations discernably worse when all other parameters (duration of exposure, protection system, etc.) are held constant? The second question really asks if pig skin and our methods of burn analyses are sensitive enough to detect small differences in heat flux.

A one way analysis of variance showed that the effect of position on heat flux was highly significant ($P=0.005$). It was necessary, therefore, to take position into account in the analysis of our results.

A multiway analysis of variance was conducted with possible main effects listed as time of exposure, position, and type of material. A "t" test of unwashed vs washed materials had shown that except for marginal significance (P=0.1) for Nomex/Standard at 7.0 seconds, the effect of washing was not significant. Therefore, all data were collapsed across washing, ie, data from washed and unwashed materials were combined. This multiway analysis of variance revealed the following:

1. There was a significant time effect in the expected direction, ie, longer time leads to more severe burn.
2. There was significant fabric effect with double-layered systems providing better protection than single layers or none (Table IV).
3. No significant first or second order interactions were found.
4. No significant position effect existed.

The main effect due to type of fabric is summarized in Table IV using gross burn evaluation.

TABLE IV
DEGREE OF BURN (GROSS) COMPARED FOR DIFFERENT
PROTECTIVE SYSTEMS

| FABRIC | 1.75 SEC n=10 | 3.5 SEC n=11 | 7.0 SEC n=12 |
|------------|------------------|-----------------|-----------------|
| O vs N | S | S | S |
| O vs N/N | S | S | S |
| O vs N/S | S | S | S |
| N vs N/N | S | S | S |
| N vs N/S | S | S | S |
| N/N vs N/S | - | X | X |

O = Control, no protection
 N = Single layer Nomex outer shell fabric
 N/N = Nomex outer shell with Nomex underwear
 N/S = Nomex outer shell with standard underwear
 - = Not significant at P=0.1
 X = Significant at P<0.05
 S = Highly significant at P<0.005

Table IV and Figure 4 show that any of the fabric systems evaluated provides some protection. The double-layered fabric systems evaluated were always superior to single-layered Nomex, and the system using standard underwear offered significantly more protection at 3.5 and 7.0 seconds. A close look at Figure 4 will indicate, however, that while these fabric systems do indeed offer some protection from burns when the flame source is set to deliver the equivalent heat flux of a well developed JP-4 fire, (6) ie, 14.0 BTU/ft²/sec (3.78 cal/cm²/sec), they do not, from the standpoint of survival, provide protection beyond some rather short time.

Table V summarizes comparisons between protective systems using the burn grades from the histopathologic studies. A multiway analysis of variance gave results similar to those for gross evaluations. (Table V)

TABLE V

DEGREE OF BURN (MICROSCOPIC) COMPARED FOR DIFFERENT PROTECTIVE SYSTEMS

| FABRIC | 1.75 SEC n=10 | 3.5 SEC n=11 | 7.0 SEC n=12 |
|------------|------------------|-----------------|-----------------|
| O vs N | - | M | - |
| O vs N/N | S | S | - |
| O vs N/NS | S | S | - |
| N vs N/N | S | S | M |
| N vs N/S | S | S | X |
| N/N vs N/S | - | - | - |

M = Marginally significant at P=0.1

- = Not significant at P=0.1

S = Highly significant at P<0.005

X = Significant at P<0.05

An analysis of the microscopic evaluation of the tissue specimens reveals that protection by single-layered Nomex is marginal or not significant and that double layers N/N and N/S) protect better ($P=0.005$) than either Nomex or no protection. At 7.0 seconds no real protection is afforded by any system since all systems experienced third degree (4.0) burns.

These results (microscopic evaluation) are accompanied by a possible source of error. In looking at the results, there are cases, where the grade given an unprotected hole is lower than an adjacent hole protected by Nomex which received a severe burn. In these cases the gross evaluation was in the expected direction (unprotected, severe; Nomex, less severe). This discrepancy can be accounted for if the biopsy was taken from a typical part of the burned area. In most cases these inconsistencies could be checked by consulting the photographs and medical illustrations.

There is no satisfactory way to correct for these apparent errors, without jeopardizing the independence of the microscopic evaluation. Therefore, the results are presented, as recorded, without any attempt to scale or "correct" the data. Subjectively, the gross evaluations appear to give more consistent data because any apparent errors can be checked with the photographs and drawings of the burns without prejudicing the evaluation.

The conclusions drawn from this experiment are tempered by the degree to which the gross and microscopic evaluations do not agree. From Figures 4 and 5, however, it is clear that the disagreement is not severe.

The time temperature data (Figures 6, 7, 8) indicate that the total tissue (skin) damage is related to the area under the time-temperature curve as pointed out by Stoll.(11) It should be noted that the recorded temperatures are the temperatures of the cloth-skin interface and not necessarily the temperatures of the surface of the skin.

The initial rise in the temperature of unprotected skin (Figures 6, 7, 8) is due to preheating by radiation from the hot shutter. This moderate preheating may affect the performance of a given fabric, but since the temperatures are well below the "melting" temperatures of the fabrics, the effect is probably minimal.

The inflection point occurring between 0.8-1.4 seconds in

single-layered Nomex curves reflects fabric break-through. On some curves for the double-layered systems, it is possible to see two inflections, one for the outer layer and one for the underwear.

It is clear that the air-skin interface reaches a steady-state temperature (unprotected and single-layered Nomex) within 7.0 seconds. (Figure 8) For the unprotected or control site this exposure results in a maximum level burn, ie, 6.0 on the gross evaluation scale.

There are three main factors that interact to determine the survivability of an aviator exposed to a post-crash fire. First, there is the thermal environment to which he is exposed. Of course, this environment varies from accident to accident. Usually there will be some short period of time during which the fire is developing into the severe thermal environment represented by the flame gun in this test. This period of warm-up acts to increase the survival time of the aviator against the case when a fire reaches "worst-credible-proportions" instantaneously.

Second, the fit of the uniform determines the degree to which a given fabric will transfer heat and cause burns. This study addressed only the case in which the fabric is closely applied to the skin, and by so doing skewed the results toward more severe burns. Less severe burns would have been observed if an air space existed between the pig and the fabric to represent a loose fitting garment. The method of application in this experiment was chosen to provide consistent data and to represent the normal garment fit in the areas of knees, elbows, shoulders, and buttocks. Our method even more closely models the garment as worn by aviators who have gained weight or wear smaller uniforms to look more "military".

Third, there are well known correlations among age, sex, and general health to severity and area of burn.(3,12) The usual rating systems weight second degree burns one-third to one-half as traumatic as third degree burns; but difficulties in accurately judging the depth of burn in the clinical situation have led to survivability tables that relate area of total burn (second and third degree) to survivability within specified age groups.(3,12)

To show how the winter flight suit might protect the aviator we present the following example. Assume that aviators are male, healthy, between the ages of 20 and 50, and receive

no more than 40% of total body area burn (second and third degree) in a worst-credible environment (well developed JP-4 fire). The time of exposure for each protective system giving rise to a severe second degree burn (level 3.0, Figures 4 and 5) using our data, is summarized in Table VI.

TABLE VI

TIME TO REACH SEVERE SECOND DEGREE BURN

| FABRIC | TIME (SEC) | |
|--------|---------------|---------------|
| | GROSS (FIG 4) | MICRO (FIG 5) |
| O | 1.2 | 1.3 |
| N | 1.8 | 1.45 |
| N/N | 5.7 | 5.6 |
| N/S | 6.4 | 6.2 |

The mortality of aviators between the ages of 20 and 52 having received such a burn is summarized in Table VII.

TABLE VII

MORTALITY (ADAPTED FROM REF 3)

(Assuming: Male, healthy, 40% area second and third degree burns and adequate medical care)

| <u>AGE</u> | <u>PROBABILITY OF DEATH</u> |
|------------|-----------------------------|
| 20 | 0.23 |
| 24 | 0.19 |
| 28 | 0.21 |
| 32 | 0.24 |
| 36 | 0.30 |
| 40 | 0.37 |
| 44 | 0.45 |
| 48 | 0.52 |
| 52 | 0.61 |

These predictions assume that the aviator received adequate medical care promptly. The survivability decreases if there is delay in stabilizing the patient and taking him to an adequate treatment center.

CONCLUSIONS

1. None of the fabric systems evaluated meet the essential requirement (10 seconds protection) for Army aviator's flight clothing.
2. Single layered fabric systems offer slight protection.
3. Double layered systems evaluated offer more than three times the protection of single layers but fail to provide 10 seconds of protection.
4. Standard underwear worn under a standard Nomex outer shell provides equal or better protection than the experimental Nomex underwear worn under a standard Nomex outer shell.
5. Washing does not affect thermal protection.
6. Our method using pigs provides a very consistent and meaningful way of evaluating thermal protective fabrics.

REFERENCES

1. Zilioli, Armand E., USAARL Report No. 71-17, "Crash Injury Economics: The Costs of Training and Maintaining an Army Aviator", Fort Rucker, Alabama, April 1971.
2. Zilioli, Armand E., USAARL Report No. 71-18, "Crash Injury Economics: Aircrewman Injury and Death Costs Occurring in UH-1 Army Aircraft Accidents in Fiscal Year 1969", Fort Rucker, Alabama, June 1971.
3. McCoy, J.A.; Micks, D.W.; and Lynch, J.B.; "Discriminant Function Probability Model for Predicting Survival in Burned Patients", JAMA 203:644-6, 1968.
4. Department of the Army Approved Small Development Requirement (SDR) for Clothing System for Army Aircrewmembers, Par 26(2), 9 February 1966.
5. Hinshaw, J. Raymond; Payne, Fred W.; "The Restoration and Remodeling of the Skin After a Second Degree Burn", Surg-Gynec. Obstet. 117:738-744, 1963.
6. Albright, John D.; Knox, Francis S., III; DuBois, David R.; and Keiser, George M.; USAARL Report No. 71-24, "The Testing of Thermal Protective Clothing in a Reproducible Fuel Fire Environment, A Feasibility Study", June 1971.
7. Perkins, J.B.; Pearse, H.E.; and Kingsley, H.D.; "Studies on Flash Burns", University of Rochester, Atomic Energy Project Report, UR-217, 1952.
8. AFIP Manual of Histologic and Special Staining Technique, 2nd Edition, New York, Blackstone Division of McGraw Hill Book Company.
9. Anderson, W.A.D., Pathology, 5th Edition, Volume 1, St. Louis, The C.V. Mosby Company, 1966.
10. Jobb, K.Y.F. and Kennedy, P.C., Pathology of Domestic Animals, 2nd Edition, Volume 2, New York, Academic Press, 1970.
11. Stoll, Alice M., "Thermal Protection Capacity of Aviator's Textiles", Aerospace Medicine, pp. 846-850, June 1962.
12. Artz, Curtis P., and Moncrief, John A., The Treatment of Burns, pp. 89-108, 2nd Edition, Philadelphia, W.B. Saunders Company, 1969.

LIST OF EQUIPMENT

VETERINARY

1. Heidbrink Model 970 - Veterinary Anesthesia Unit
2. CAP-CHUR Equipment (Palmer Chemical and Equipment Company)
3. Drugs
 - a. Sernylan (phencylidine hydrochloride - Parke-Davis)
 - b. Thorazine (chlorpromazine - Pitman-Moore)
 - c. Penthrane (methoxyflurane - Abbot)
 - d. Atropine Sulfate

EXPERIMENTAL APPARATUS

1. Flame gun - Conversion oil burner, modified Lennox, Model OB-32, loaned by the National Aviation Flight Engineering Center, NAFEC, Atlantic City, New Jersey.
2. Fuel - Kerosene

DATA ACQUISITION

1. HyCal, Model C1300 water cooled calorimeters
2. Omega, 0.005 inch and 0.032 inch unshielded, chromel alumel thermocouples
3. Technirite, Model TR-888 strip chart recorder.
4. Consolidated Electrodynamics, Model 5-124 recording oscillograph
5. Non-Linear Systems, DART LX-2 digital multimeter
6. Standard SW-1 Timer
7. GraLab Universal, 60 minute, Electric timer