

# ESD ACCESSION LIST

TRI Call No. 74884

Copy No. 1 of 1 cys.

# ESD RECORD COPY

RETURN TO  
SCIENTIFIC & TECHNICAL INFORMATION DIVISION  
(TRI), Building 1210

TRI FILE COPY

**Technical Note**

**1971-41**

A. J. Simmons

**Study  
of Antenna Pattern Coverage  
for a UHF Antenna System  
on an Aircraft**

13 September 1971

Prepared under Electronic Systems Division Contract F19628-70-C-0230 by

## Lincoln Laboratory

MASSACHUSETTS INSTITUTE OF TECHNOLOGY

Lexington, Massachusetts



AD0732914

Approved for public release; distribution unlimited.

MASSACHUSETTS INSTITUTE OF TECHNOLOGY  
LINCOLN LABORATORY

STUDY OF ANTENNA PATTERN COVERAGE  
FOR A UHF ANTENNA SYSTEM ON AN AIRCRAFT

*A. J. SIMMONS*

*Group 61*

TECHNICAL NOTE 1971-41

13 SEPTEMBER 1971

Approved for public release; distribution unlimited.

LEXINGTON

MASSACHUSETTS

The work reported in this document was performed at Lincoln Laboratory, a center for research operated by Massachusetts Institute of Technology, with the support of the Department of the Air Force under Contract F19628-70-C-0230.

This report may be reproduced to satisfy needs of U.S. Government agencies.

## ABSTRACT

An idealized study of theoretical patterns of a four-element crossed-slot array on a cylinder approximating the fuselage of a KC-135 aircraft has been carried out. The objective is to obtain complete hemispherical coverage with at least 6 dB gain for circular polarization over the band from 250 to 400 MHz. The study shows that 15 beam positions, requiring switching each antenna between  $0^\circ$  and three values of phase shift, will give nearly the desired coverage. Coverage is limited over a small portion of the region, primarily in the fore-aft directions, because of the drop in gain of the individual array elements in these directions. An optimum location for the array on the side of the fuselage is chosen at an angle of  $60^\circ$  from the zenith. (A similar array is required on the opposite side of the aircraft to give coverage on the other side.) The effects of multipath reflections are calculated and found to be negligible because of the circular polarization discrimination of the antenna.

Accepted for the Air Force  
Joseph R. Waterman, Lt. Col., USAF  
Chief, Lincoln Laboratory Project Office

## Study of Antenna Pattern Coverage for a UHF Antenna System on an Aircraft

Continuing the program described in Ref. 1, a theoretical antenna pattern study has been made to attempt an optimization of the design of a four-element crossed-slot phased array for aircraft - satellite communication. The study has extended the work described in Ref. 1 to include the following factors:

1. Study of the entire band 250 - 400 MHz.
2. Pattern calculation based on the actual size of an experimental crossed-slot antenna which has been successfully matched over the above band.
3. Configuration of the four antennas which result in closest spacing of the radiators (Fig. 17b, Ref. 1). See Fig. 1.
4. Locations of the antenna on the fuselage at other than  $50^\circ$  from the vertical.
5. Consideration of multipath interference.

The following criteria were used to optimize the design:

1. Directivity of 6 dB or greater with respect to a circularly polarized source desired at all frequencies over the upper hemisphere and down to  $-10^\circ$  below horizontal to allow for aircraft attitude changes.
2. The required number of beam positions to be a minimum.
3. At each beam position, the beam pointing angle is independent of frequency (time delay phase shifters are used).

4. The number of phase shifter sections (or bits) to be a minimum.

The pattern calculation is based on the theoretical patterns for thin slots on an infinite cylinder of approximately the radius of a KC-135 aircraft. Mutual coupling was ignored on the assumption that its effects could be compensated for in the feed network. Thus it was assumed that each slot was fed with equal amplitude, that the pair of slots in each crossed-slot antenna were fed in phase quadrature to produce circular polarization, and that the phase between array elements could be prescribed exactly. The element patterns for the individual slots were taken as the theoretical patterns of isolated thin slots on a cylinder, one set of slots being axial and the other set circumferential.

Because of the difference in gain and phase of the radiation patterns from axial and circumferential slots, the axial ratio of the single crossed-slot antenna was not unity on axis, but varied between 1.3 to 1.4 dB over the frequency band. No attempt was made to improve this axial ratio by varying the phase or amplitude fed into the slots, as it was felt that this was a negligible factor in practice.

Patterns are calculated in a  $(\theta', \varphi')$  coordinate system oriented with respect to the antenna, with the z-axis along the cylinder axis, and  $\varphi' = 0$  the normal to the array. Patterns are then transformed to a system with respect to the aircraft coordinates  $(\theta, \varphi)$  with the z-axis pointing to the zenith and dead ahead corresponding to  $\varphi = 0$ . In the  $\theta', \varphi'$  coordinates, only one quadrant of the  $\theta', \varphi'$  plane need be studied, as patterns in other quadrants are obtained

by reflection in the axes, which corresponds to reversal of relative phase of the array elements. The following steps were taken to optimize the design.

1. Calculate patterns in the  $\theta'$ ,  $\varphi'$  plane to give complete coverage with the minimum number of beam positions. This study was performed at 400 MHz where beamwidths are a minimum. Care had to be taken to neglect extraneous lobes (grating lobes) which appear at this frequency, particularly in the diagonal plane of the array, and have as much gain as the desired lobes. These grating lobes cannot be used for communication for they change direction with frequency. Figure 2 is a typical plot of the sector of interest in the  $\theta'$ ,  $\varphi'$  plane showing 6 dB contours for various beams. It was found that the area covered by the sum of the 6 dB contours of the different beams corresponded roughly to the 1 dB contour of the element pattern. This is to be expected since the array has about 5 dB greater gain than the single element. It is clear that the element pattern sets a fundamental limitation on the coverage which can be obtained, particularly in the diagonal planes in the  $(\theta', \varphi')$  coordinate system.

2. Minimize the phase shifter complexity. The beams shown in Fig. 2, with the elimination of the four beams numbered 7, are essentially those chosen to obtain the complete coverage, for a total of 15 beam positions. The phases of the beams shown in Fig. 2 were modified slightly when it was found that a change of  $\pm 10^\circ$  in the phases of the elements at 400 MHz would reduce the required number of phase shift bits from 4 to 3. The change in

coverage was insignificant. Table I shows the relative phase values required at 400 MHz, and the phase shift bits which make them up. In the type of phase shift network under consideration, the total phase shift for any pair of elements must remain constant, i. e. , all bits must be used. This restriction is satisfied by the values shown. The other 9 beam positions are obtained by reversing the up-down phase, forward-aft phase or both.

Phase shift values for other frequencies may be obtained from Table I by multiplying the values on the table by a scale factor  $F/400$ ,  $F$  in MHz.

3. Calculate the coverage in the aircraft coordinate system. Figures 3, 4, and 5 show contour plots at three frequencies of the coverage achieved in one quadrant by use of the phase shift values shown in Table I and the appropriately scaled values at the other frequencies. The area in which coverage is greater than 6 dB is shaded. These plots are for the array located at an angle  $50^\circ$  around the cylinder (fuselage) from the top.

The plots represent a coordinate system where the zenith direction is at the center, circles of constant elevation are plotted every  $10^\circ$  and points are plotted every  $2^\circ$  in azimuth. The elevation scale is non-linear so that equal areas in the plane represent equal areas on the sphere of which the plane is a map. Because of this non-linearity, the circles of constant elevation (latitude circles) crowd together at the outside of the plot, which represents the underside of the sphere. The final circle plotted is the  $170^\circ$  circle.

The sector for which coverage is desired is the quadrant inside the  $100^\circ$

TABLE I  
RELATIVE PHASES REQUIRED AT 400 MHz FOR THE SIX BASIC BEAM POSITIONS

| <u>Beam Number</u> | 1         | 2           | 3           |
|--------------------|-----------|-------------|-------------|
|                    | Rel Phase | Phase Bits  | Rel Phase   |
| Array 1 (up)       | 0°        | 180°        | 0°          |
| Array 3 (down)     | 20°       | 80° + 120°  | 220°        |
| Array 2 (forward)  | 20°       | 80° + 120°  | 120°        |
| Array 4 (aft)      | 0°        | 180°        | 100°        |
|                    |           | 180°        | 80°         |
|                    |           | 80° + 120°  | 120° + 180° |
|                    |           | 80°         | 80° + 120°  |
|                    |           | 120° + 180° | 180°        |

| <u>Beam Number</u> | 4         | 5                 | 6         |
|--------------------|-----------|-------------------|-----------|
|                    | Rel Phase | Phase Bits        | Rel Phase |
| Array 1 (up)       | 0°        | 80°               | 0°        |
| Array 3 (down)     | 220°      | 120° + 180°       | 380°      |
| Array 2 (forward)  | 0°        | 80°               | 200°      |
| Array 4 (aft)      | 220°      | 120° + 180°       | 180°      |
|                    |           | 0°                | 0°        |
|                    |           | 80° + 120° + 180° | 380°      |
|                    |           | 80° + 120°        | 120°      |
|                    |           | 180°              | 260°      |
|                    |           | 80° + 120° + 180° | 80 + 180° |

depression angle. As can be seen, coverage is not complete, falling below 6 dB in regions that correspond to the diagonal planes in the  $(\theta', \varphi')$  plane of the array. Six dB coverage cannot be expected beyond the contours shown because of the element pattern — to show this, the 1 dB contours of the element patterns are shown by x's in Figs. 3, 4, and 5.\*

The individual beams making up the coverage shown in Fig. 5 are shown in Fig. 6. Note that the beams 2M, 4M, and 6M are the mirror images of the beams 2, 4, and 6, respectively, obtained by reversing the up-down phase shifters in the array.

4. Study the effect of variation in array positions on coverage. Because the coverage is apparently limited by the element patterns, no improvement is to be expected by adding more beam positions. The coverage may be changed by changing the position of the array on the fuselage. Patterns were computed for the same array at an angle of  $60^\circ$  from the top of the fuselage, in an attempt to improve the low angle coverage, and these contour plots are shown in Figs. 7, 8, and 9. The change in coverage between the  $50^\circ$  and  $60^\circ$  positions is shown in Figs. 10, 11, and 12. In general, about as much area is subtracted as is added, but on balance since more area is added at low

---

\* Measurements made for a single crossed-slot antenna on an actual aircraft give somewhat broader coverage than these theoretical patterns on an infinite cylinder (see Ref. 2). It is possible therefore that the coverage areas calculated in Figs. 3, 4, and 5 may represent a pessimistic case as compared to actual practice.

elevation angles (near  $90^\circ$ ) it is felt that changing to the  $60^\circ$  position of the antennas represents a net improvement. This is so because the probability is higher of the satellite being at a low elevation angle than at a high elevation angle. Figure 13 plots the probability a geo-stationary satellite will be seen at or below a given zenith angle, assuming equal probability for any location on earth within the sector from which the satellite is visible. As can be seen, the probability is greater than .5 that the satellite will be at zenith angles greater than  $60^\circ$  (elevation angles below  $30^\circ$ ). This probability will be even greater if the aircraft operates mainly in higher latitudes.

5. Multipath considerations. One factor which might deter moving the array around to  $60^\circ$  is the increased illumination of the earth's surface with the broadside beam, resulting in the possibility of increased multipath effects. Figure 14 shows the broadside ( $\varphi = 90^\circ$ ) pattern of the array in beam position 2 at the lowest frequency, 250 MHz, where multipath should be worst. Three patterns are shown, representing the directivity in dB to vertical, horizontal and circular polarization. Two scales of zenith angle ( $\theta$ ) are shown, one for  $50^\circ$  position, the other for  $60^\circ$  position. The discrimination against the reflected rays coming from angles greater than  $90^\circ$  is clearly better for the  $50^\circ$  than for the  $60^\circ$  case. However, because the antennas are circularly polarized, the multipath reflection is discriminated against. Figures 15 and 16 show the calculated effect of multipath reflections for linear polarization for the cases of  $50^\circ$  and  $60^\circ$  antenna position. The top curves in each case

are the free-space directivity pattern, the same as Fig. 14 with expanded horizontal axis. The bottom curves show the minimum signal, assuming the aircraft is at such a height as to give maximum cancellation between the direct and reflected rays. The reflection coefficient of a smooth sea at 250 MHz was assumed and the earth's curvature neglected for simplicity of calculation. Note that for linear polarization the 60° case is definitely worse than the 50° case. However, at angles above 5° elevation, the sea surface reflection is mainly of opposite circular hand compared to the incident signal, so that the array tends to be blind to the reflected signal. The field strength of the reflected signal seen by the antenna relative to the direct signal, assuming a perfectly circularly polarized source, is given by the formula

$$R = \frac{V(\theta^-) \Gamma_V(\theta) - j H(\theta^-) \Gamma_H(\theta)}{V(\theta^+) - j H(\theta^+)} \quad (\text{Ref. 3})$$

where

$\theta \pm$  is the angle  $\begin{cases} \text{above} \\ \text{below} \end{cases}$  the horizon,

$V(\theta)$  is a complex quantity whose magnitude is the vertically polarized directivity, and whose phase is that of the vertically polarized radiation pattern,

$H(\theta)$  is a similar quantity for horizontal polarization,

$\Gamma_V(\theta)$  and  $\Gamma_H(\theta)$  are the complex vertical and horizontal reflection coefficients respectively of the sea surface.

Using this formula, and the calculated magnitudes and phases of the vertically and horizontally polarized antenna radiation patterns, the depth of the interference minima may again be calculated for circular polarization and are presented in Figs. 17 and 18. The reduction in directivity is severe only near grazing incidence and is essentially the same for the two antenna locations. Therefore, there seems to be no reason not to use the  $60^\circ$  position because of multipath considerations.

#### Conclusions

An idealized study of theoretical patterns of a four-element crossed-slot array on a cylinder approximating the fuselage of a KC-135 has been carried out. The effect of the finite length of the true aircraft, of the blockage by the tail assembly and possible wing reflections have been neglected. Also neglected for the time being are the effects of mutual coupling on the patterns — it is assumed that these effects can be compensated for in the network used to feed the array. Losses in the phase shifters and feedlines have been neglected in all calculations of directivity.

Subject to the above assumptions, it has been found that 15 beam positions are sufficient to give coverage on one side of the aircraft over the band 250 – 400 MHz, with signal levels in excess of 6 dB over a substantial portion of the region to be covered. The 15 beam positions can be achieved by

switching three values of phase shift (plus a  $0^\circ$  value) between the up-down pair of antennas and the fore-aft pair. If line lengths are used to achieve these phase values, the beam positions will be frequency independent.

The coverage is limited fundamentally by the element pattern of the crossed-slot antenna, so that in certain areas in the fore-aft sections at low elevation angles the coverage drops below 6 dB. This low angle coverage may be improved slightly at the expense of high angle coverage by moving the array down on the fuselage to an angle of  $60^\circ$  from the top, rather than  $50^\circ$  as originally suggested. A study of the multipath problem indicates that because the antenna is circularly polarized the multipath problem is no worse at  $60^\circ$  than it was at  $50^\circ$ , and in any case is almost negligible except within  $1 - 2^\circ$  of grazing incidence on the sea.

#### ACKNOWLEDGMENT

The author wishes to thank Mr. Leon Niro for his assistance in the computation of the radiation patterns presented here.

## REFERENCES

1. M. L. Rosenthal, "VHF Antenna System for Aircraft," Technical Note 1970-8, Lincoln Laboratory, M. I. T. (12 March 1970).
2. A. L. Johnson, M. A. Miller, "Three Years of Airborne Communication Testing via Satellite Relay," WPAFB Avionics Laboratory, Report No. AFAL-TR-70-156 (November 1970).
3. This equation may be derived from:  
V. H. Rumsey, et al., "Techniques for Handling Elliptically Polarized Waves with Special Reference to Antennas," Proc. IRE 39, 534 (see Part 1, Eq. 10) (May 1951).

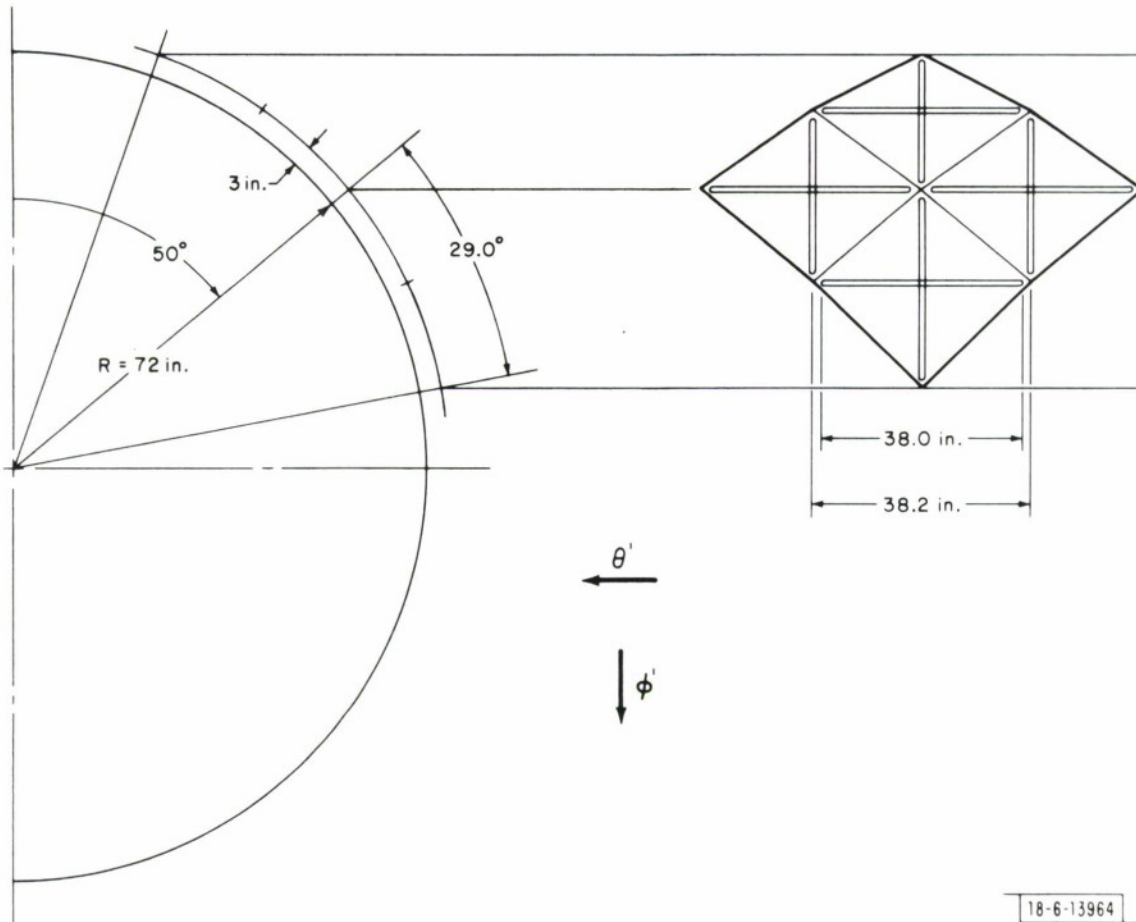

18-6-13964

Fig. 1. Proposed configuration of antennas on cylinder.

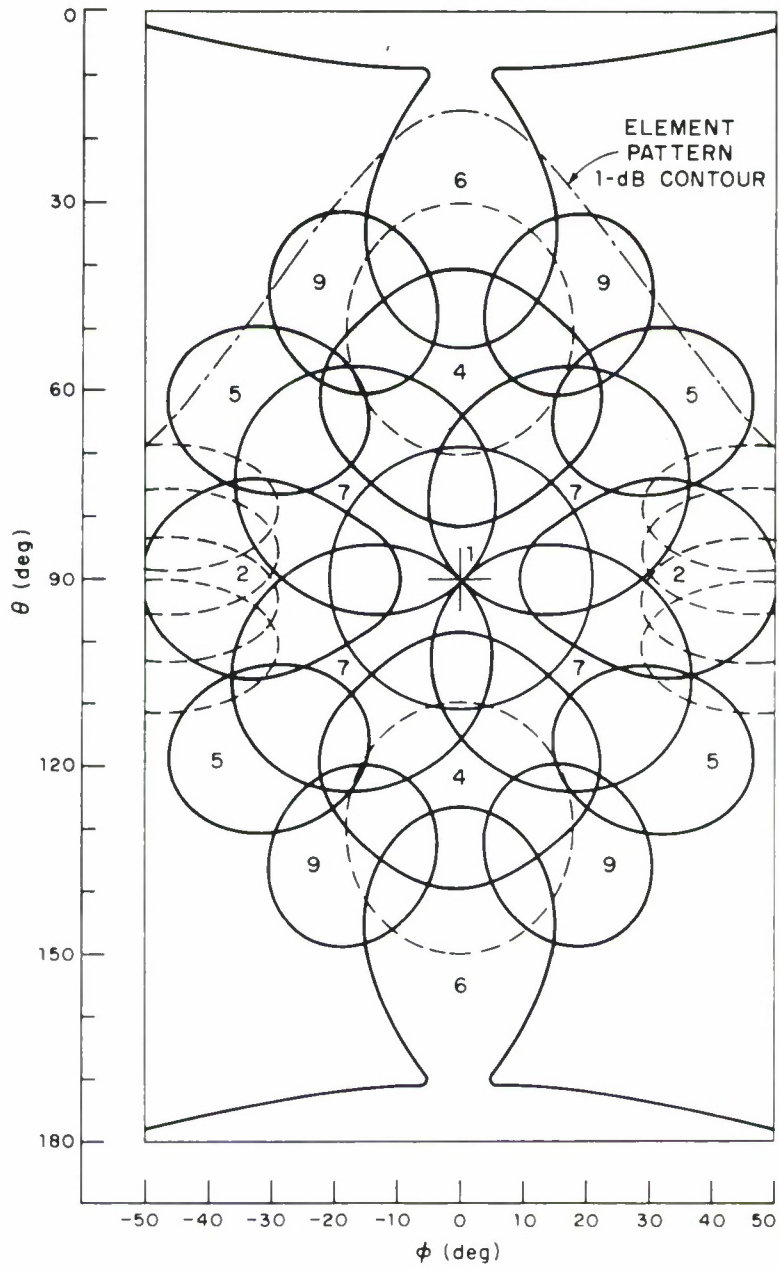

Fig. 2. Six-dB contours in the  $(\theta', \phi')$  plane, 400 MHz.

MAX OF DIR. GAIN TO CIRCULAR POL

RADIUS OF CYL = 1.59 LAMBDA  
DEPRESSION ANGLE = 50.00 DEG

MAX DIRECT = 11.52  
X 1-dB CONTOUR  
ELEMENT  
PATTERN

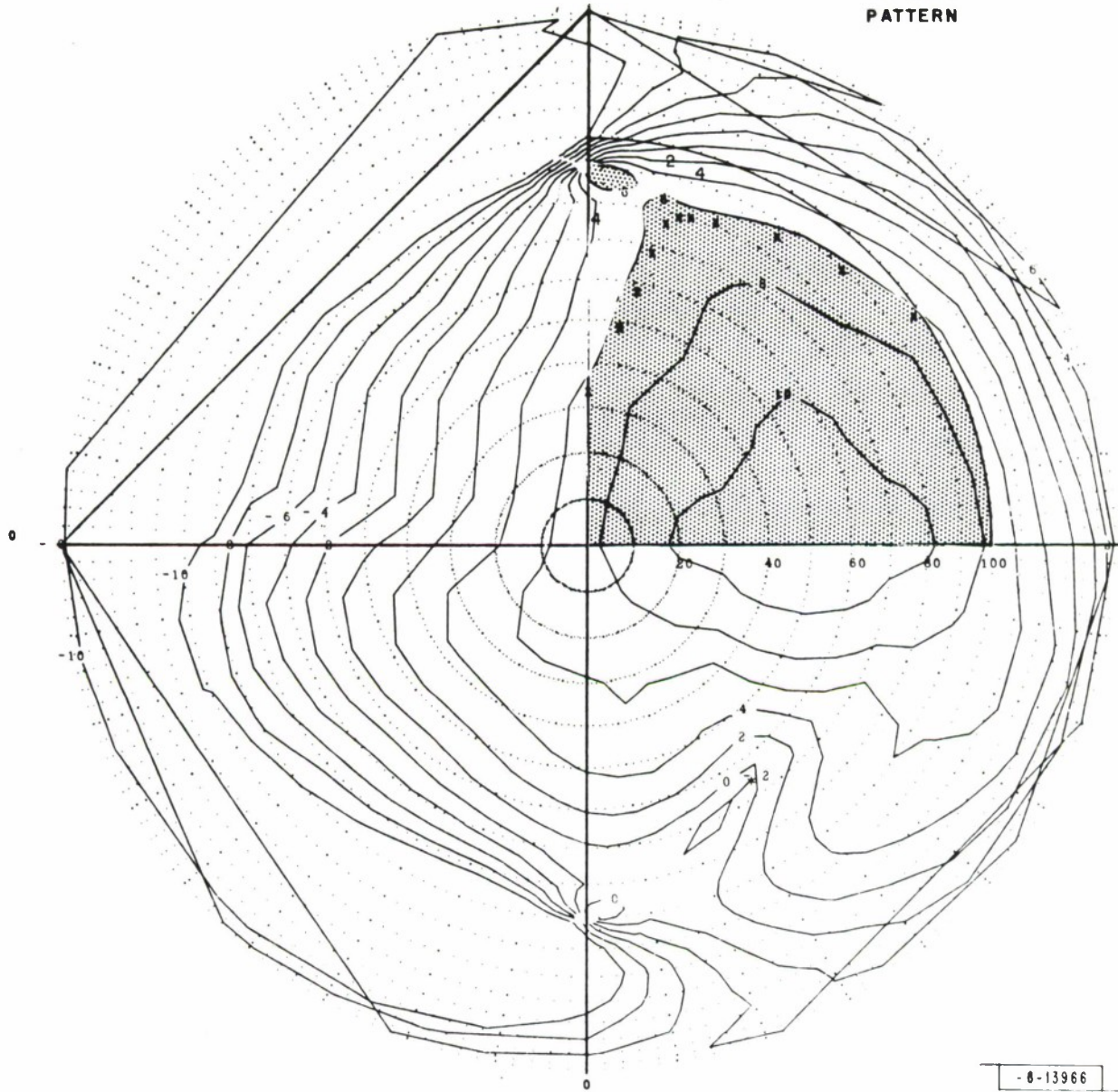

Fig. 3. Contour plot in the  $(\theta, \varphi)$  plane, 250 MHz,  $50^\circ$  depression angle.

MAX OF DIR. GAIN TD CIRCULAR POL

RADIUS OF CYL = 1.92 LAMBDA  
DEPRESSION ANGLE = 50.00 DEG

MAX DIRECT = 11.22  
X 1-dB CONTOUR  
ELEMENT  
PATTERN

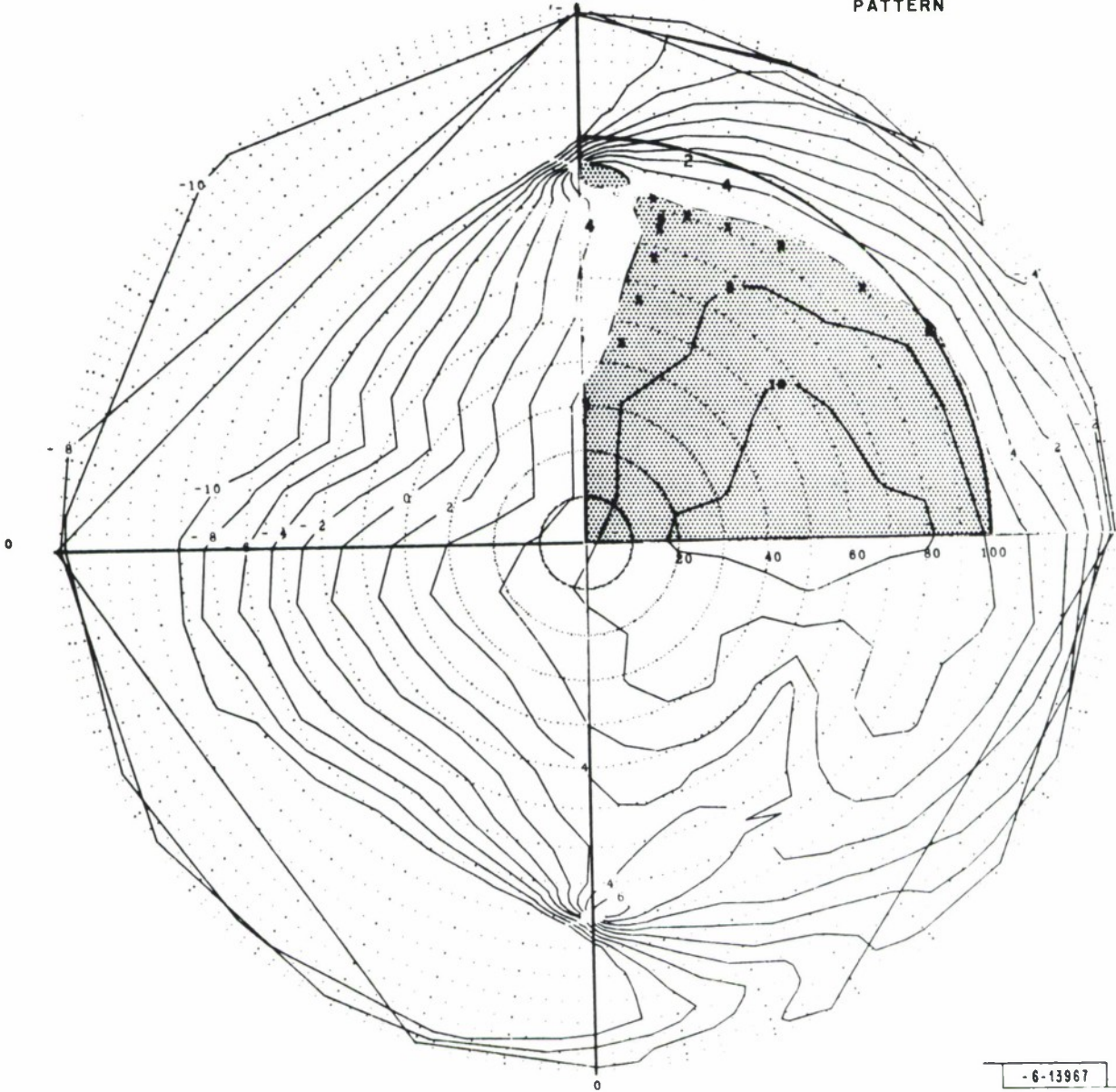

Fig. 4. Contour plot in the  $(\theta, \phi)$  plane, 300 MHz,  $50^\circ$  depression angle.

MAX OF DIR. GAIN TO CIRCULAR POL

RADIUS OF CYL = 2.54 LAMBDA  
DEPRESSION ANGLE = 50.00 DEG

MAX DIRECT = 11.61  
X 1-dB CONTOUR  
ELEMENT  
PATTERN

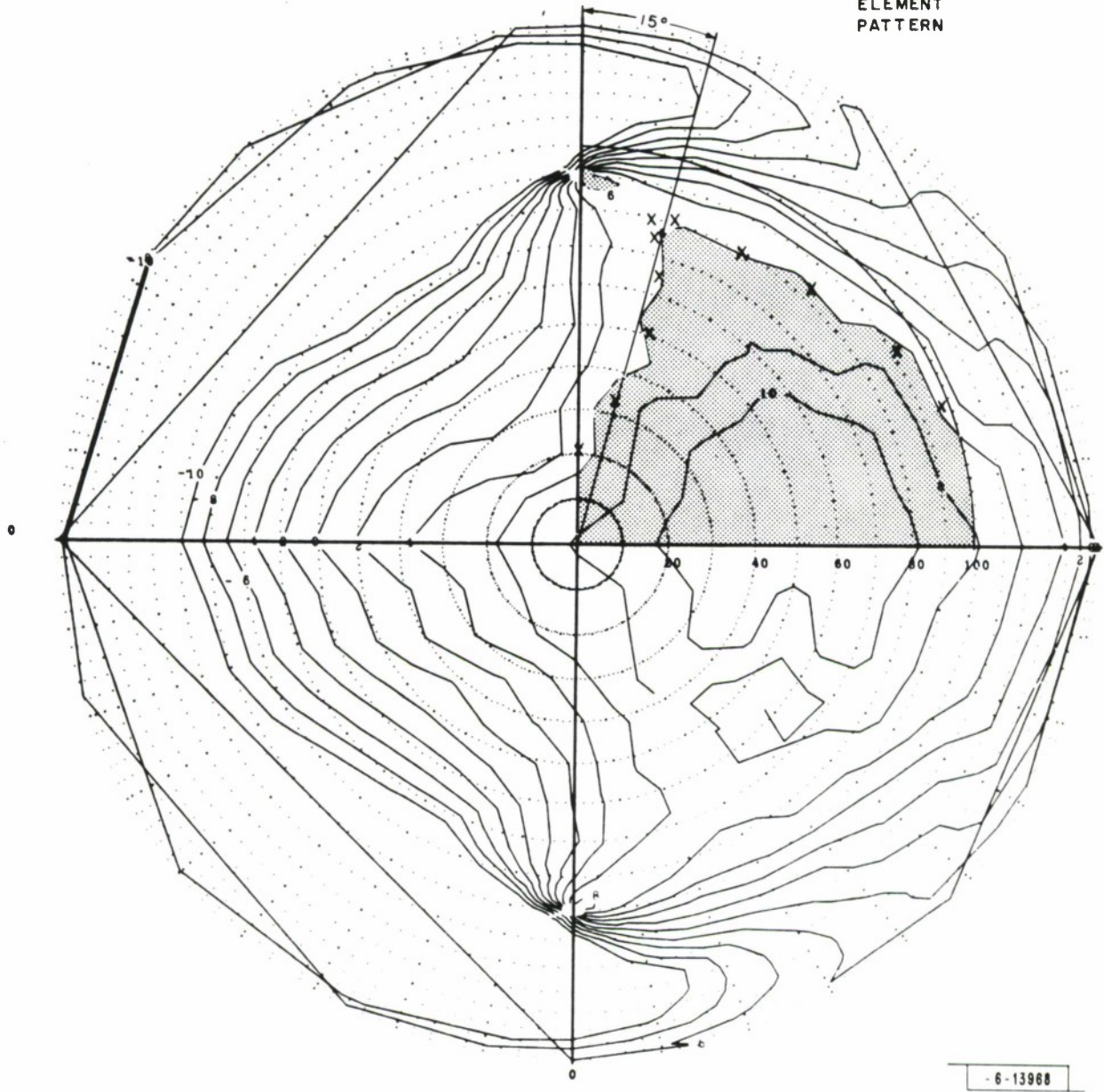

Fig. 5. Contour plot in the  $(\theta, \phi)$  plane, 400 MHz,  $50^\circ$  depression angle.

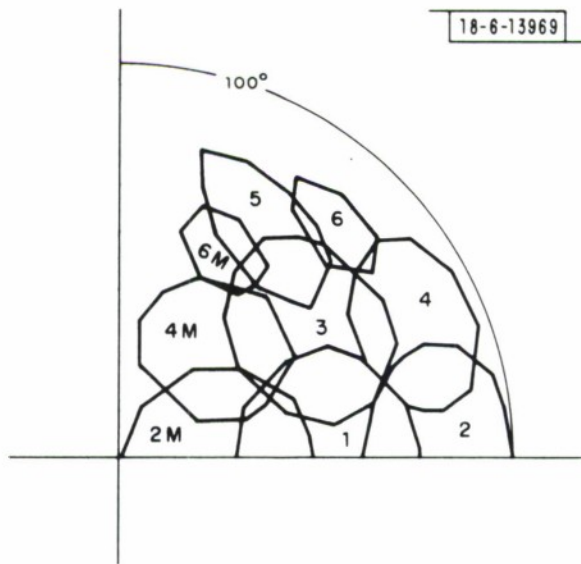

Fig. 6. Six-dB contours in the  $(\theta, \varphi)$  plane, 400 MHz.

MAX OF DIR. GAIN TO CIRCULAR POL

RADIUS OF CYL = 1.50 LAMBDA  
DEPRESSION ANGLE = 60.00 DEG

MAX DIRECT = 11.52

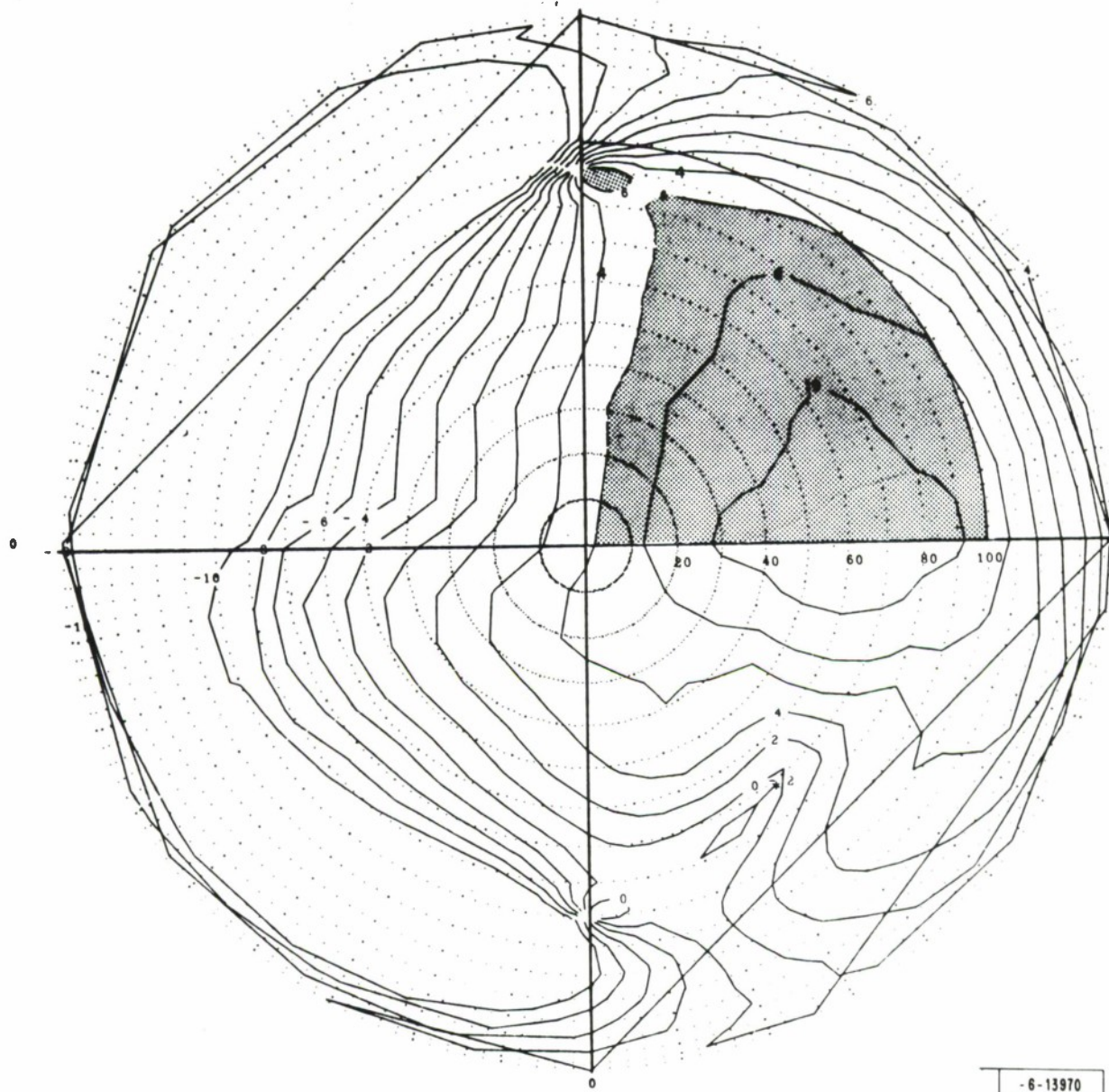
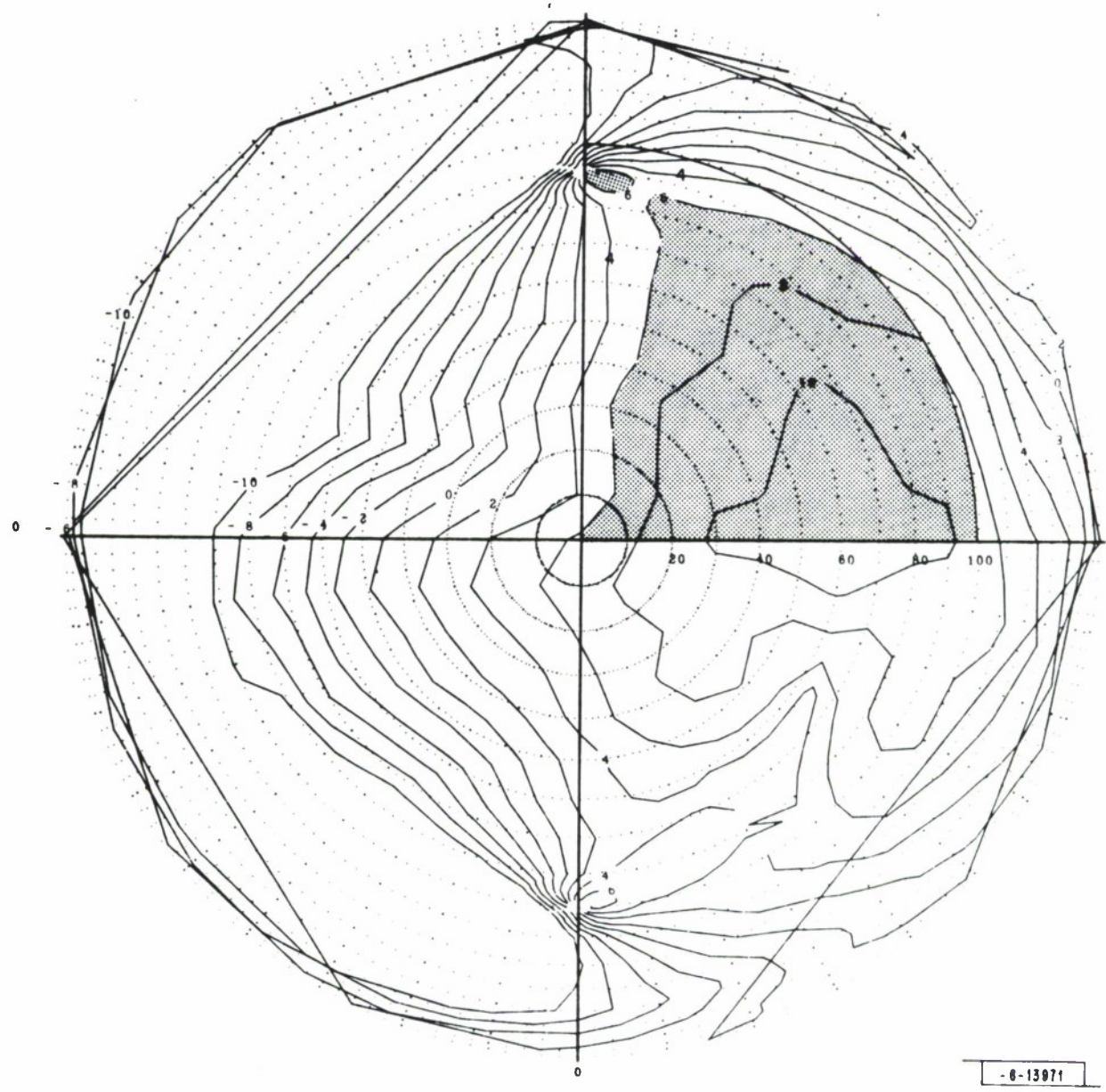

Fig. 7. Contour plot in the  $(\theta, \phi)$  plane, 250 MHz,  $60^\circ$  depression angle.

MAX OF DIR. GAIN TO CIRCULAR POL

RADIUS OF CYL = 1.92 LAMBDA  
DEPRESSION ANGLE = 60.00 DEG

MAX DIRECT = 11.22



- 6-13971

Fig. 8. Contour plot in the  $(\theta, \phi)$  plane, 300 MHz,  $60^\circ$  depression angle.

MAX OF DIR. GAIN TO CIRCULAR POL

RADIUS OF CYL = 2.84 LAMBDA  
DEPRESSION ANGLE = 60.00 DEG

MAX DIRECT = 11.61

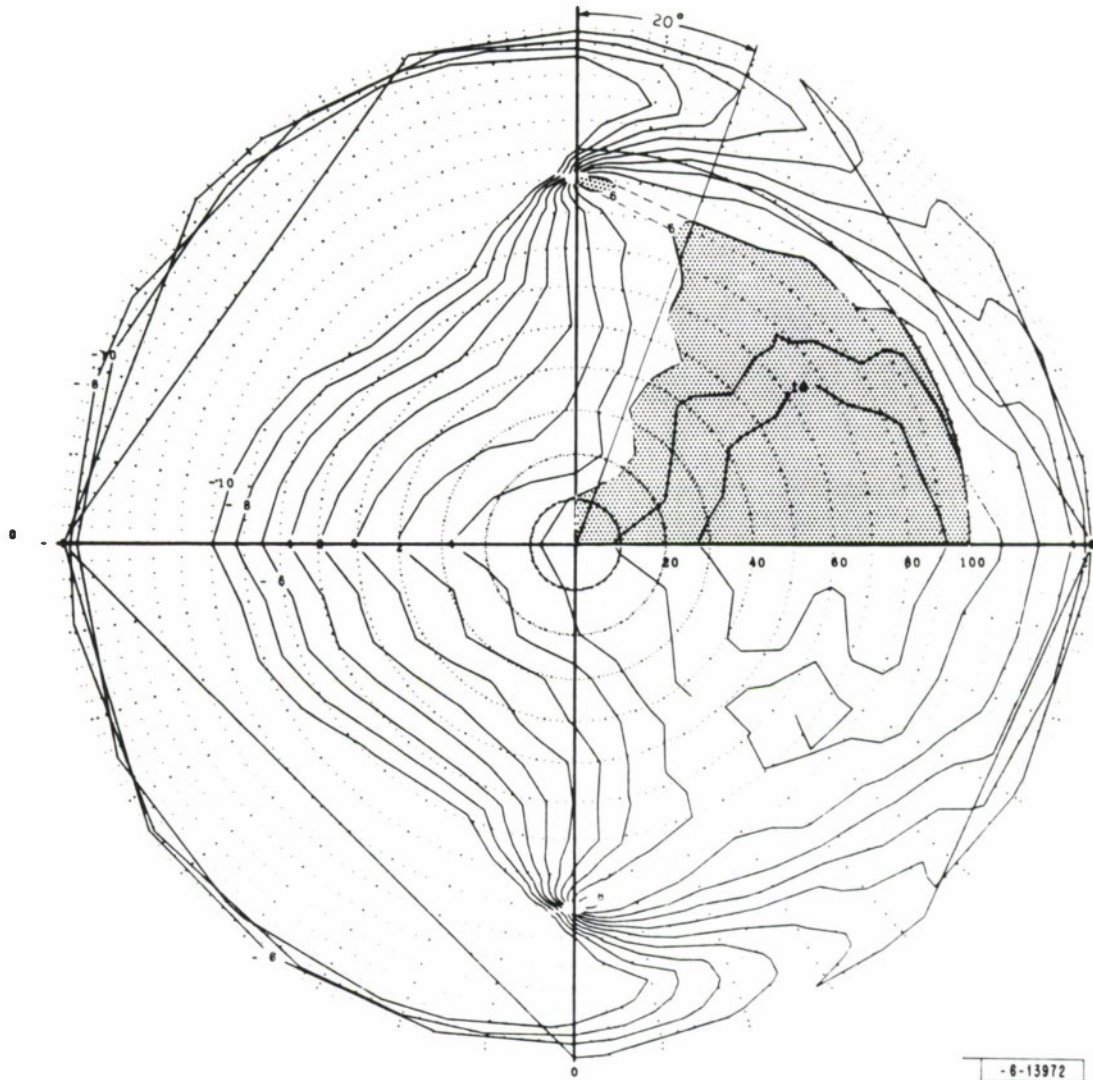

Fig. 9. Contour plot in the  $(\theta, \phi)$  plane, 400 MHz,  $60^\circ$  depression angle.

Fig. 10. Change in coverage with change in depression angle from  $50^\circ - 60^\circ$ , 250 MHz.

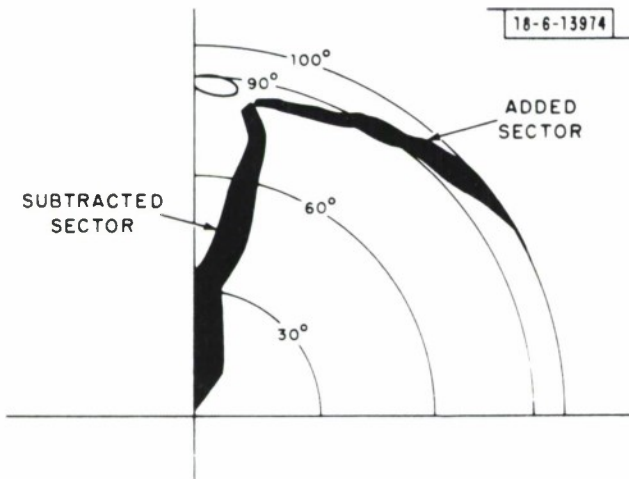
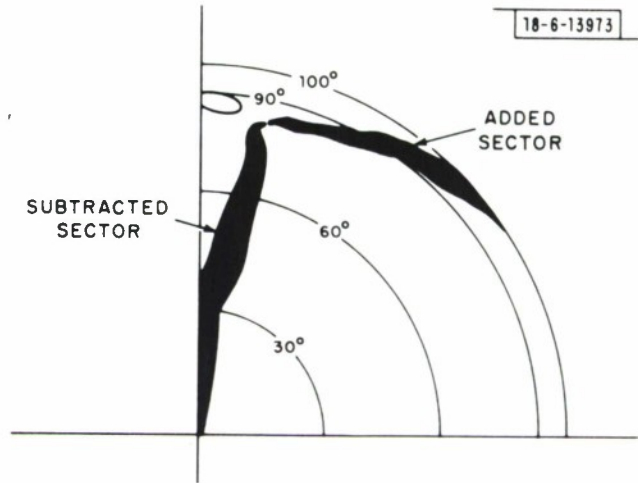
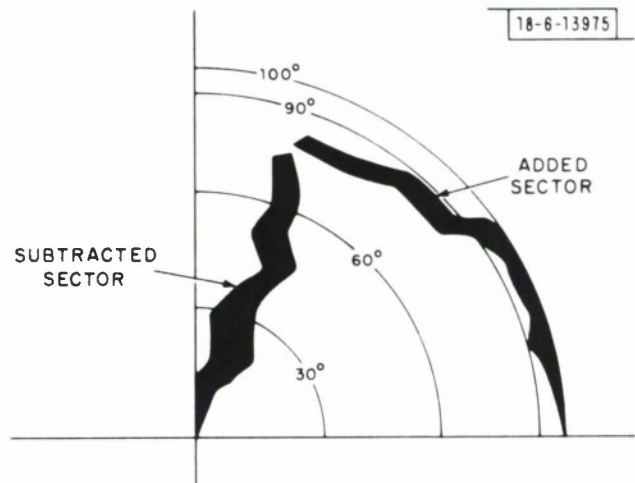

Fig. 11. Change in coverage with change in depression angle from  $50^\circ - 60^\circ$ , 300 MHz.

Fig. 12. Change in coverage with change in depression angle from  $50^\circ - 60^\circ$ , 400 MHz.



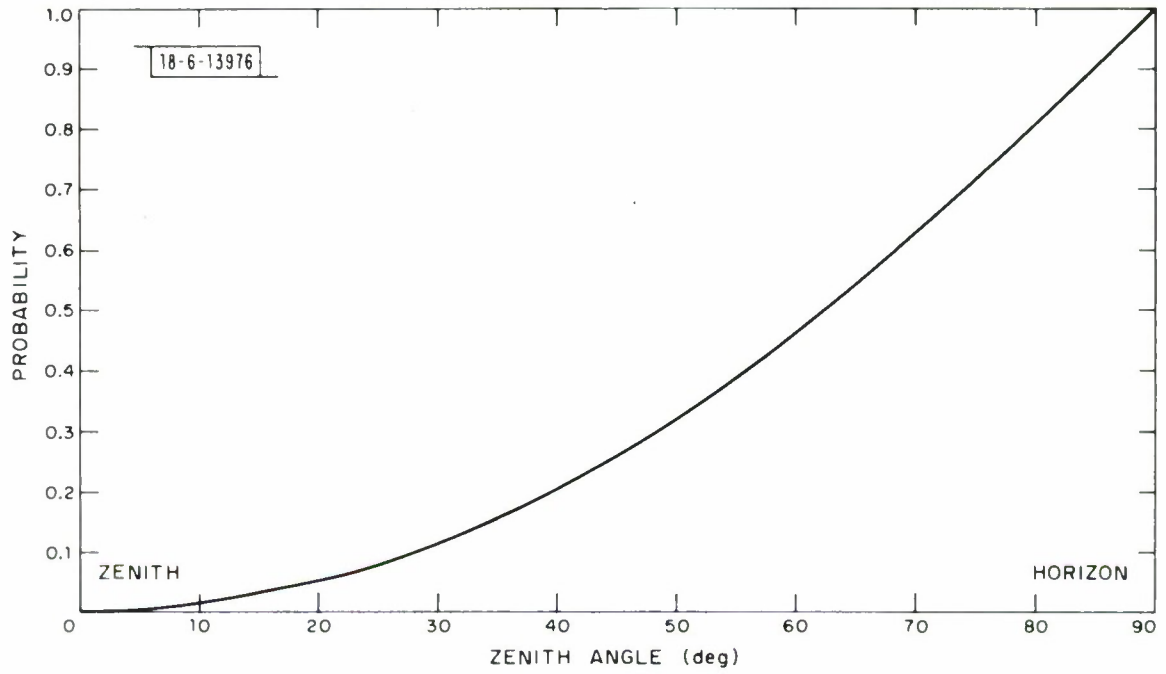

Fig. 13. Probability that zenith angle is less than a given value.

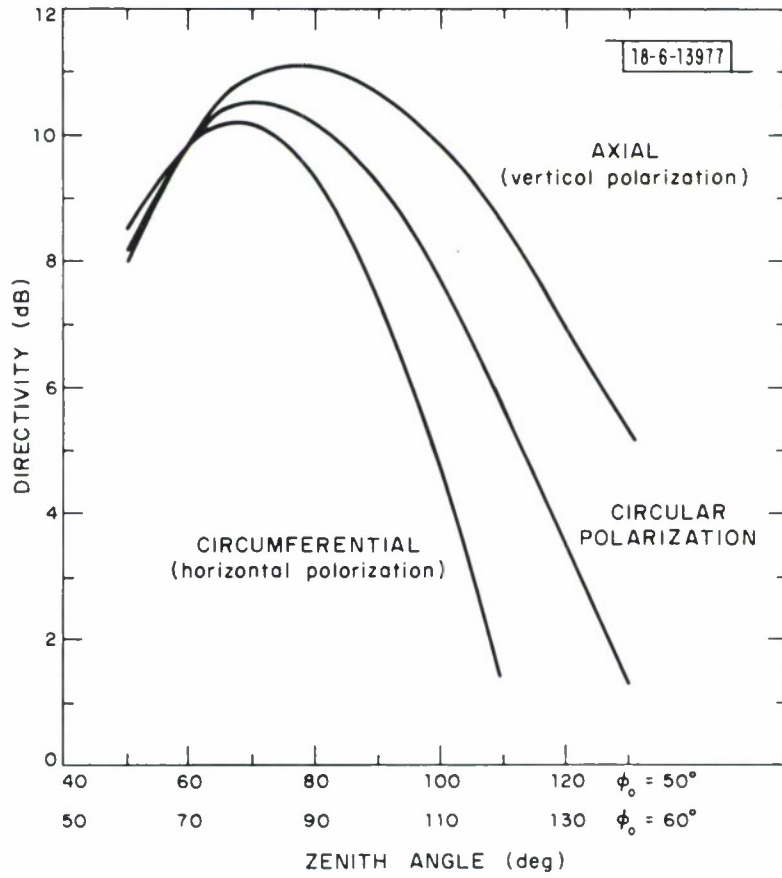

Fig. 14. Broadside directive gain pattern of beam #2 at 250 MHz.

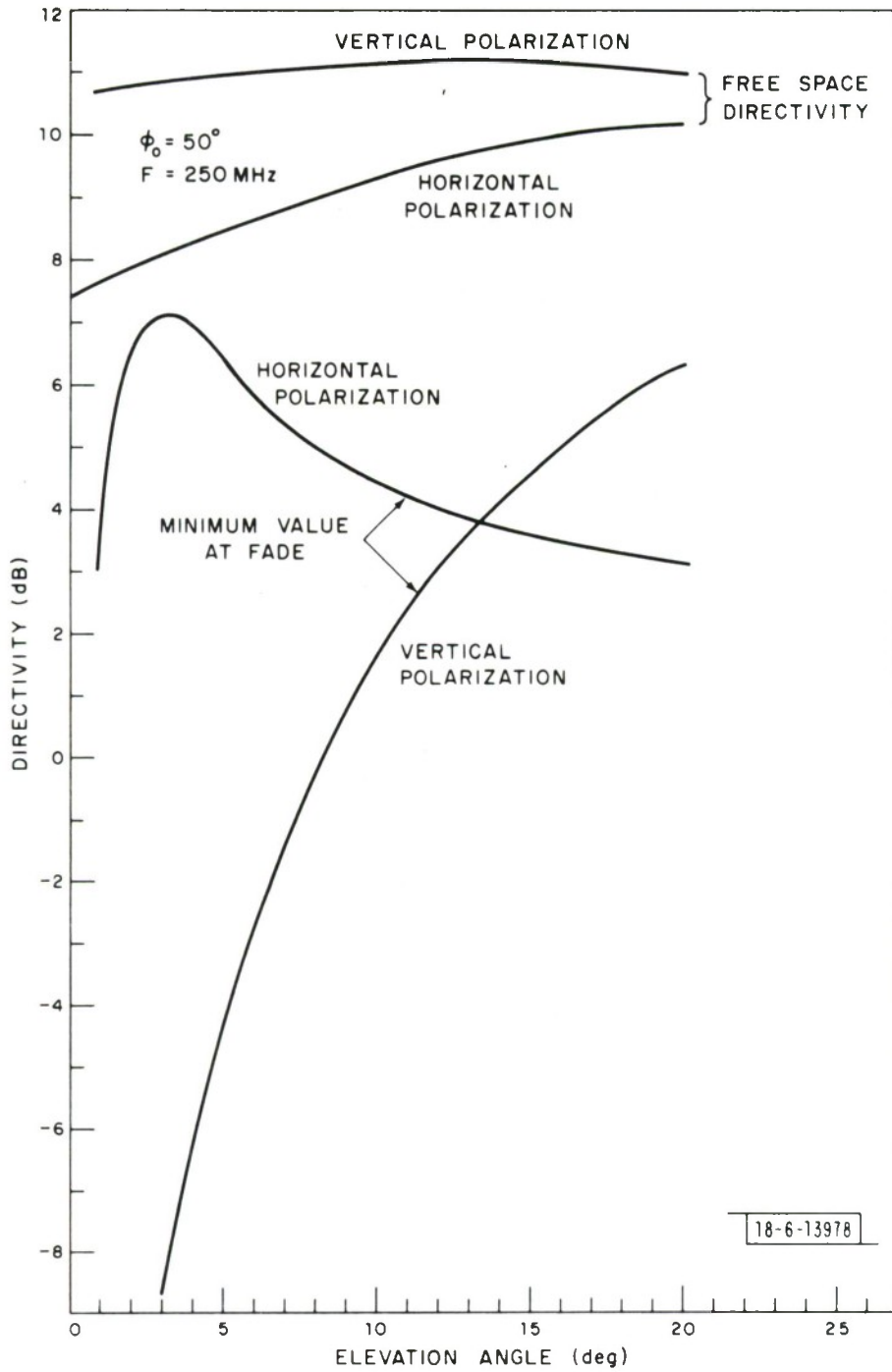

Fig. 15. Effect of multipath for linear polarization,  $50^\circ$  depression angle.

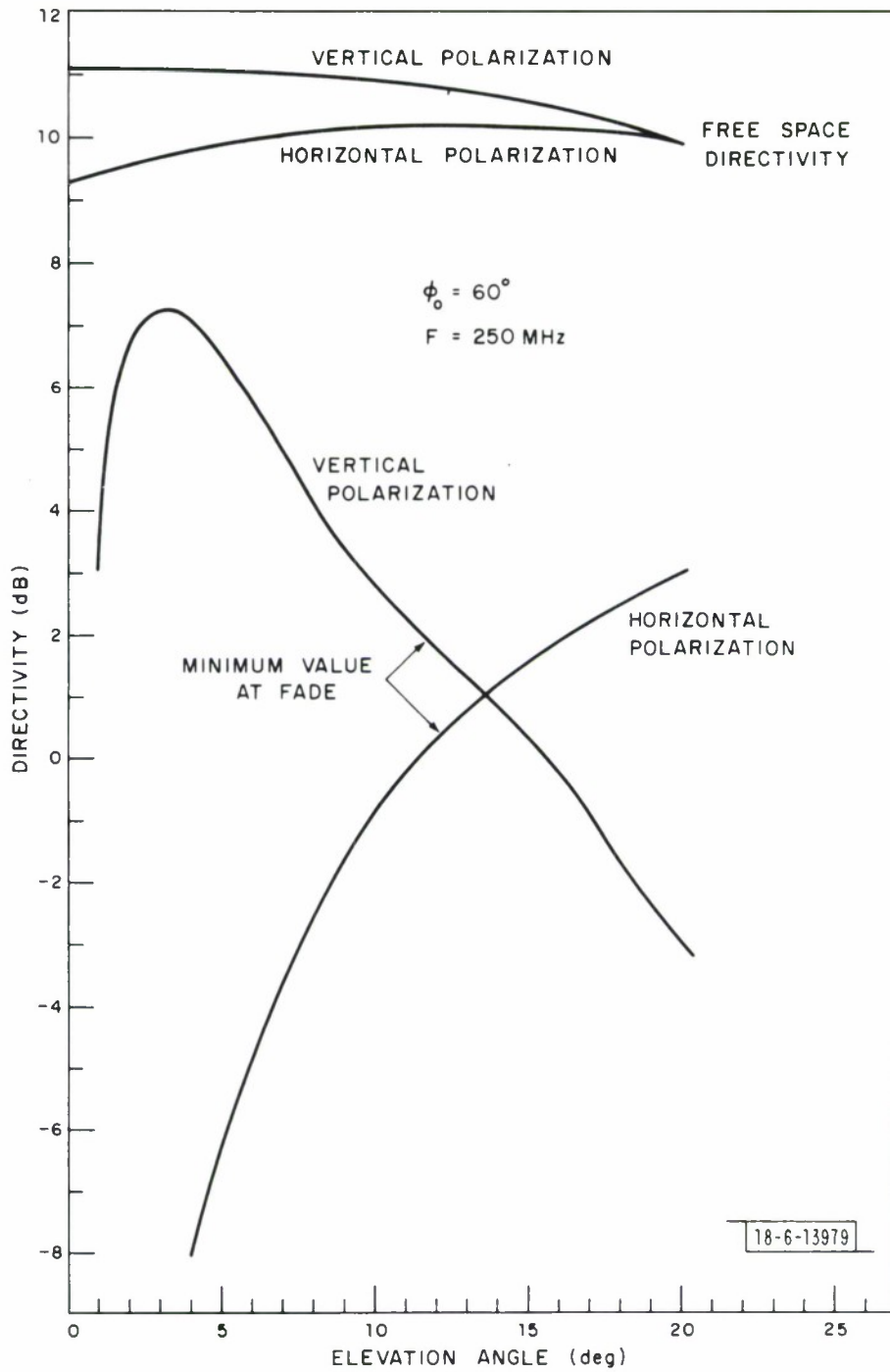

Fig. 16. Effect of multipath for linear polarization,  $60^\circ$  depression angle.

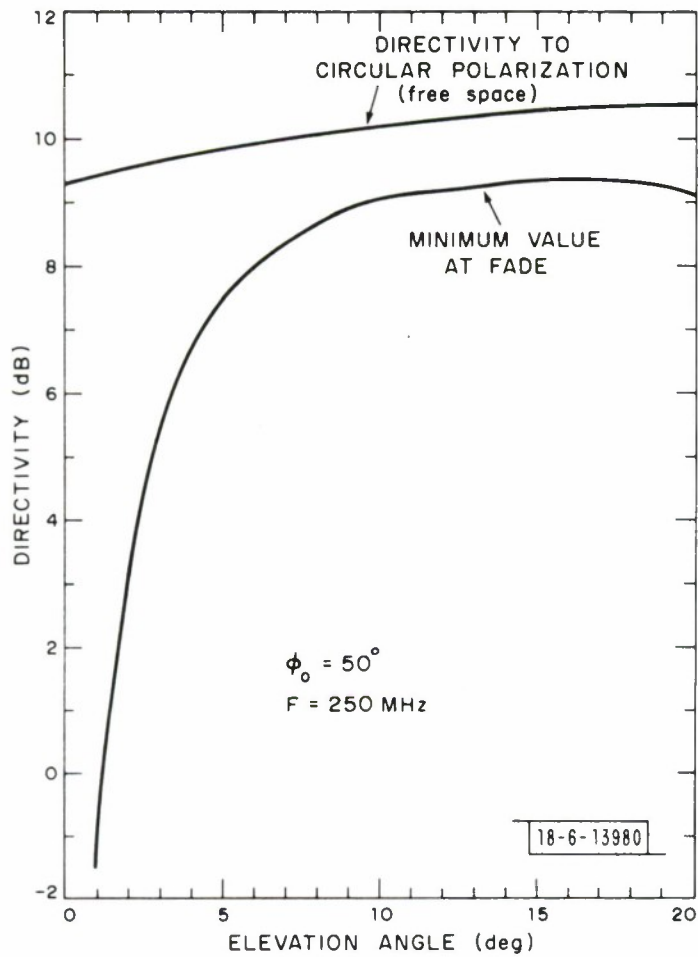

Fig. 17. Effect of multipath for circular polarization,  $50^\circ$  depression angle.

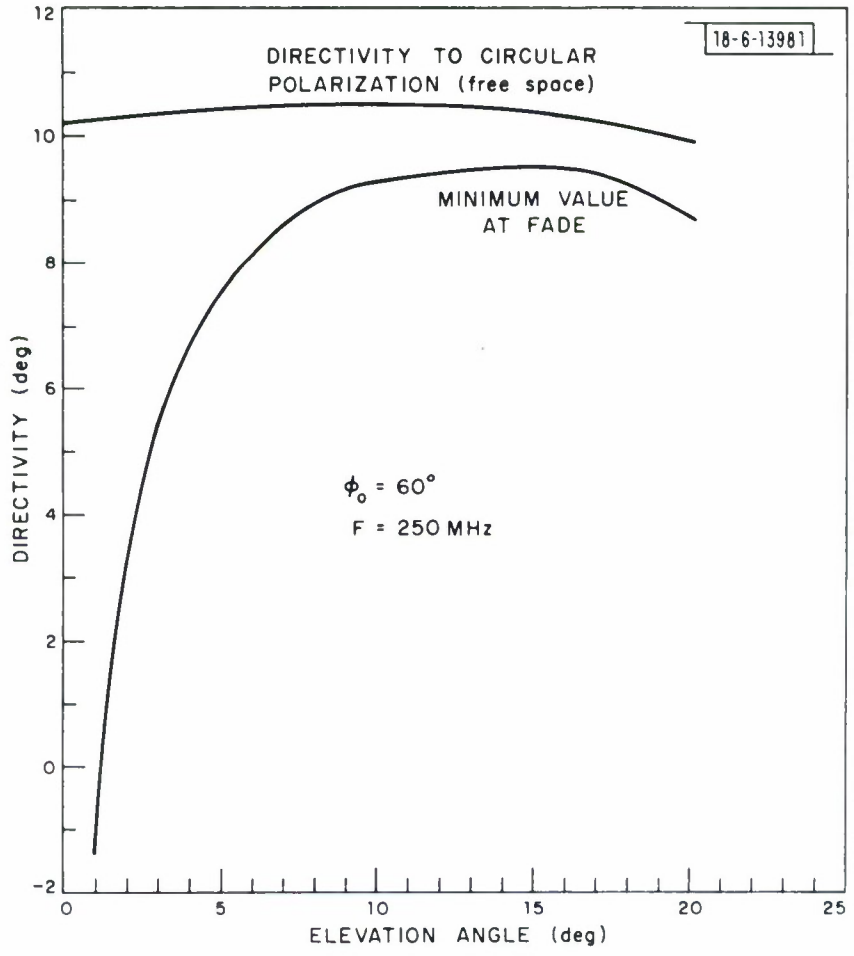

Fig. 18. Effect of multipath for circular polarization,  $60^\circ$  depression angle.

| <b>DOCUMENT CONTROL DATA - R&amp;D</b>  |   |                          |
|---|---|--------------------------|
| <i>(Security classification of title, body of abstract and indexing annotation must be antared when the overall report is classified)</i>   |   |                          |
| 1. ORIGINATING ACTIVITY <i>(Corporata author)</i><br><br>Lincoln Laboratory, M. I. T.   | 2a. REPORT SECURITY CLASSIFICATION<br>Unclassified  |                          |
|   | 2b. GROUP<br>None   |                          |
| 3. REPORT TITLE<br><br>Study of Antenna Pattern Coverage for a UHF Antenna System on an Aircraft  |   |                          |
| 4. DESCRIPTIVE NOTES <i>(Type of report and inclusive dates)</i><br>Technical Note  |   |                          |
| 5. AUTHOR(S) <i>(Last name, first name, initial)</i><br><br>Simmons, Alan J.  |   |                          |
| 6. REPORT DATE<br><br>13 September 1971   | 7a. TOTAL NO. OF PAGES<br><br>32  | 7b. NO. OF REFS<br><br>3 |
| 8a. CONTRACT OR GRANT NO. F19628-70-C-0230  | 9a. ORIGINATOR'S REPORT NUMBER(S)<br><br>Technical Note 1971-41   |                          |
| b. PROJECT NO. 649L   | 9b. OTHER REPORT NO(S) <i>(Any other numbers that may be assigned this report)</i><br><br>ESD-TR-71-263 |                          |
| c.  |   |                          |
| d.  |   |                          |
| 10. AVAILABILITY/LIMITATION NOTICES<br><br>Approved for public release; distribution unlimited.   |   |                          |
| 11. SUPPLEMENTARY NOTES<br><br>None   | 12. SPONSORING MILITARY ACTIVITY<br><br>Air Force Systems Command, USAF                                 |                          |
| 13. ABSTRACT<br><br>An idealized study of theoretical patterns of a four-element crossed-slot array on a cylinder approximating the fuselage of a KC-135 aircraft has been carried out. The objective is to obtain complete hemispherical coverage with at least 6 dB gain for circular polarization over the band from 250 to 400 MHz. The study shows that 15 beam positions, requiring switching each antenna between 0° and three values of phase shift, will give nearly the desired coverage. Coverage is limited over a small portion of the region, primarily in the fore-aft directions, because of the drop in gain of the individual array elements in these directions. An optimum location for the array on the side of the fuselage is chosen at an angle of 60° from the zenith. (A similar array is required on the opposite side of the aircraft to give coverage on the other side.) The effects of multipath reflections are calculated and found to be negligible because of the circular polarization discrimination of the antenna. |   |                          |
| 14. KEY WORDS   |   |                          |
| space communications<br>antenna patterns<br>UHF antenna<br>KC-135   | circular polarization<br>array elements<br>multipath reflections  |                          |