

TECHNICAL REPORT
72-3-CE

AD 734984
AD

LIGHTWEIGHT INSULATED FOOTWEAR

by

R. A. Mazzeo
Uniroyal, Inc.
Naugatuck, Conn.

Contract No. DAAG17-79-C-0003



September 1971

Reproduced by
NATIONAL TECHNICAL
INFORMATION SERVICE
Springfield, VA 22101

Clothing & Personal Life Support Equipment
Laboratory
CAMPBELL 9a

81

DISCLAIMER NOTICE

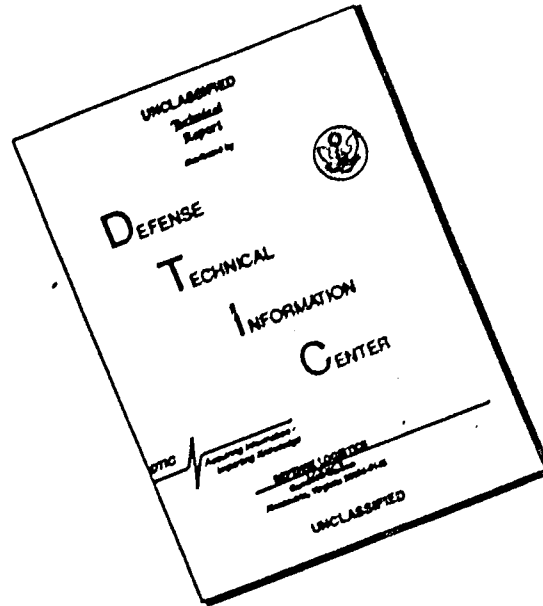

THIS DOCUMENT IS BEST QUALITY AVAILABLE. THE COPY FURNISHED TO DTIC CONTAINED A SIGNIFICANT NUMBER OF PAGES WHICH DO NOT REPRODUCE LEGIBLY.

UNCLASSIFIED

Security Classification

DOCUMENT CONTROL DATA - R & D		
<i>(Security classification of title, body of abstract and indexing annotation must be entered when the overall report is classified)</i>		
1. ORIGINATING ACTIVITY (Corporate author)		2a. REPORT SECURITY CLASSIFICATION
Uniroyal, Inc. Naugatuck, Conn.		Unclassified
2b. GROUP		
3. REPORT TITLE		
Lightweight Insulated Boots		
4. DESCRIPTIVE NOTES (Type of report and inclusive dates)		
Final July 1969 - November 1971		
5. AUTHOR(S) (First name, middle initial, last name)		
R. A. Mazzeo		
6. REPORT DATE	7a. TOTAL NO. OF PAGES	7b. NO. OF REFS
September 1971	79	
8a. CONTRACT OR GRANT NO.	8b. ORIGINATOR'S REPORT NUMBER(S)	
DAAG17-70-C-0003	72-9-CL (C&PLS) - ()	
b. PROJECT NO. 1J662713DJ10	92	
c.	9d. OTHER REPORT NO(S) (Any other numbers that may be assigned this report)	
d.		
10. DISTRIBUTION STATEMENT		
Approved for public release; distribution unlimited.		
11. SUPPLEMENTARY NOTES	12. SPONSORING MILITARY ACTIVITY	
	U. S. Army Natick Laboratories Natick, Mass. 01760	
13. ABSTRACT		
<p>Compound formulations having good low temperature flexibility were developed for the outsole, upper and outer skin of the lightweight insulated boot.</p> <p>The proper insulation thickness for the entire boot was determined from foot insulation test data to produce a boot having sufficient overall insulation.</p> <p>In an attempt to improve traction, a Vibram type outsole design was used.</p> <p>Susceptibility to puncture from ground objects was reduced by redesign of the outsole, and by spraying a thicker outer skin at the base of the boot.</p> <p>The ankle portion of the last was redesigned to provide a snugger fit and eliminate slippage at the heel while walking.</p> <p>A nylon sock lining to permit ease of donning and doffing was developed.</p>		

DD FORM 1473

1 NOV 68

REPLACES DD FORM 1473, 1 JAN 64, WHICH IS OBSOLETE FOR ARMY USE.

UNCLASSIFIED

Security Classification

14 KEY WORDS	LINK A		LINK B		LINK C	
	ROLE	WT	ROLE	WT	ROLE	WT
Design	8					
Development	9					
Lightweight footwear	9					
Insulated footwear	9					
Boots	9		9		9	
Spraying	10					
Tests			8			
Insulation			9		9	
thickness			9		9	
Puncturing			9		9	
Improvement					8	
Flexibility					9	
Low Temperature					9	
Traction					9	
Adhesion					9	

Approved for public release;
distribution unlimited

AD _____

TECHNICAL REPORT

70-9-GE

LIGHTWEIGHT INSULATED FOOTWEAR

By

R. A. Mazzeo
Uniroyal, Inc.
Naugatuck, Connecticut

Contract No. DAAG17-70-C-0003

Project Reference:
1J662713DJ40

Series: C&PLSEL-⁹²

September 1971

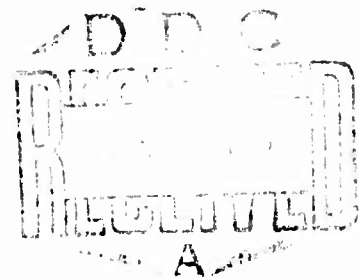

Clothing and Personal Life Support Equipment Laboratory
U. S. ARMY NATICK LABORATORIES
Natick, Massachusetts

FOREWORD

The standard black insulated US Army boots developed for cold-wet conditions weigh approximately 40-43 ounces per boot. In reference to energy consumption of the combat soldier, studies indicate that one ounce of weight carried on the foot is equivalent to six ounces carried on the back (two 40-ounce boots are equivalent to 30 pounds) of the combat soldier. In view of this, the development of new lightweight materials for insulated footwear is essential. The boots should be in the weight range of 24-26 ounces per boot (size 9R), durable, flexible and offer environmental protection at temperatures as low as -20°F. The US Army Natick Laboratories (NLABS) determined to meet this objective through advances made in materials technology and by the development of new design criteria and processing techniques.

This report describes the work performed during the 16-month period from 11 July 1969 to 30 November 1970, and is a continuation of the program previously initiated with UniRoyal, Incorporated. Under the supervision of Project Officer Joseph E. Assaf, US Army Natick Laboratories, the materials and processing studies, and the development of production procedures culminating in the production of lightweight polyurethane insulated footwear by an integrally casting techniques were performed by UniRoyal, Inc., Naugatuck, Connecticut under Project Reference 1J662713DJ40, through Contract No. DAAG-17-70-C-0003.

The Project Officer wishes to acknowledge the assistance of Mr. Douglas S. Swain, Footwear Technologist, US Army Natick Laboratories, relative to design considerations and to thank Dr. Ralph F. Goldman and Mr. O. F. Campagnone of the US Army Research Institute of Environmental Medicine (ARIEM) at Natick for conducting the copper foot calorimeter studies and for their recommendations.

TABLE OF CONTENTS

	<u>Page</u>
List of Tables	iv
List of Figures	v
Abstract	vii
Introduction	1
A. Materials	42
B. Last and Mold Design	53
C. Testing	56
D. Production Processes	63
E. Description of Prototype Pairs	64
Print No. E-3089-1	65
Print No. E-3089-2	66
Print No. D-3089-6	73
F. Informal Information on Additional Pairs of Prototype Boots R-3001-13,-14, and R-3003-1,-2	76
G. Conclusions	77
Acknowledgements	78-79
Appendix - List of Materials	

LIST OF TABLES

<u>Table</u>	<u>Page</u>
I Initial Outer Skin Formulations (PHR)	3
II Tear Test Results	5
II A Stress - Strain Data	6
III Outer Skin Formulations (Parts/Hundred)	10
III A Outer Skin Formulations and Physical Properties	11-12
IV Selected Outer Skin Formulations	14
V Physical Properties of Outer Skin Formulations	15
V A Physical Properties of Outer Skin Formulations	16
V B Physical Properties of Outer Skin Formulations	17
V C Physical Properties of Outer Skin Formulations	18
V D Comparison of Properties of Outer Skins	23
VI Twenty-Four Hour Operating Cycles for Long Range Storage in Environmental Chamber at US Army Natick Laboratories	25
VII Physical Properties of Aged Outer Skin Formulations	26-28
VIII Physical Properties of Outer Skin Formulations Aged Six Months	30
IX Foam Samples	38
X Finalized Formulations and Physical Properties of Outsole and Upper Insulation	39
XI Foot Insulation Data	44
XII Prototype Boots R-3001	67-68
XII A Typical Physical Properties of Prototype Boots R-3001	69
XII B Insulation Thickness of Prototype Boots R-3001	70
XIII Compound Formulations of Prototype Boots	71
XIII A Typical Physical Properties for Prototypes R-3002 Through R-3007	72
XIV Typical Physical Properties of 50 Pair of Prototype Boots R-3003	75

LIST OF FIGURES

<u>Figure</u>		<u>Page</u>
1	Tear Test Results	7
2	Stress Strain Data	8
3	Vibrathane B-602 vs. Vibrathane B-605	9
4	Puncture Resistance vs. Tensile Strength vs. Toughness	19
5	Toughness of Outer Skin Formulations	21
5 A	Toughness of Outer Skin Formulations	22
6	Toughness Curve For Natural Rubber Outer Skin	24
7	Physical Properties of Starting Formulations for Polyurethane Foam Outsole	32
8	Physical Properties of Polyurethane Foam Having 25 lbs/cu. ft. Density	33
9	Comparison of Molded Foam and Free Blown Foam Densities	34
10	Density vs. Percent Water Absorption	35
11	Percent Cut Growth	41
12	Proposed Insulation Thickness in Mils	45
13	Vibram Lug Design Outsole	46
14	Outsole Design A	48
15	Outsole Design B	49
16	Outsole Design C	50
17	Outsole Design D	51
18	Outsole Design E	52
19	Foot Insulation Test Zones	54
20	Schematic of Laboratory Boot Making Machine	58
21	Schematic of Laboratory Boot Spraying Machine	59
22	Schematic of Proposed Process for Manufacturing Lightweight, Insulated Polyurethane Footwear	60

ABSTRACT

Compound formulations having good low temperature flexibility were developed for the outsole, upper and outer skin of the lightweight, insulated boot.

The proper insulation thickness for the entire boot was determined from foot insulation test data to produce a boot having sufficient overall insulation.

In an attempt to improve traction, a Vibram type outsole design was used.

Susceptibility to puncture from ground objects was reduced by redesign of the outsole, and by spraying a thicker outer skin at the base of the boot.

The ankle portion of the last was redesigned to provide a snugger fit and eliminate slippage at the heel while walking.

A nylon sock lining to permit ease of donning and doffing was developed.

INTRODUCTION

The goal of this project was to make improvements on the cast lightweight insulated footwear previously developed. The major objectives of the project were as follows:

- (1) Increase the low temperature flexibility of the overall boot.
- (2) Increase insulation thickness.
- (3) Improve sprayed outer skin adhesion to the edge of the outsole.
- (4) Improve the puncture resistance of the sprayed outer skin.
- (5) Redesign last to obtain snugger fit at the ankle.
- (6) Improve outsole traction.

Studies were initiated to determine the best compounds for improving the sprayed outer skin, insulation and outsole. A snug ankle aluminum last was designed and constructed in an initial attempt to improve fit.

Foot insulation tests were conducted on the Copper Foot at the U.S. Army Natick Laboratories on a lightweight insulated boot constructed under a previous project before and after wear testing 100 miles to determine if any change occurred in the insulation value of the boot. A standard pair of Size 10 government cold weather boots were also tested for 100 miles so that a comparison of outsole wear could be made between the standard boot and newly developed boots.

Compound formulations having improved low temperature flexibility were developed. Foot insulation studies of different boot thicknesses led to a boot which has increased foam thickness in certain required areas and improved overall insulation. Teflon coated molds instead of mold release were used to avoid mold release interference with the adhesion of the sprayed-on skin. Also, the height of the edge of the outsole was reduced to improve the flexibility of the outsole.

The initial last was redesigned so that a finalized last intermediate between the snug ankle last and the wide leg last, utilized in a previous project, resulted. The outsole was redesigned and the outsole compound was reduced in hardness so that improved traction might result.

Actual wear tests for at least 200 miles indicated that the overall insulation value of the boot did not significantly decrease.

Many types of sock linings, including those made of nylon, urethane coated nylon and polyvinyl chloride (PVC) coated cotton were evaluated. A nylon/rubber/cotton laminate was selected because of the good slip qualities of the nylon and the good adhesion of the cotton to the polyurethane foam.

Eight pairs of seven different prototype boots were fabricated and submitted to the U.S. Army Natick Laboratories.

A. Materials

1. Sprayed Outer Skin

The sprayed outer skin formulations developed under past projects were not adequate for the proposed new construction of a lightweight insulated boot since they did not stretch sufficiently to provide for a new tight ankle last design. Also, they had to be made more puncture resistant and more flexible at low temperatures (-10° F).

A good skin formulation is characterized by (1) low modulus so that it will stretch when the boot is applied and removed from the foot; (2) high tensile and tear values so that the skin is more puncture resistant and durable; and (3) low temperature flexibility so that the skin will not stiffen at -20° F.

An initial series of polyurethane outer skin formulations was compounded and evaluated (Table I). These compounds were formulated using Vibrathane B-602 and Vibrathane B-605 prepolymers in conjunction with the following curatives: meta phenylene diamine (mPDA); para phenylene diamine (pPDA); methylene dianiline (MDA); and 1, 4-butanediol. Vibrathane B-602 prepolymer is the reaction product of polytetramethylene ether glycol (PTMEG) and toluene diisocyanate (TDI). Vibrathane B-605 prepolymer is the reaction product of PTMEG and 4,4'-diphenylmethane diisocyanate (MDI). Plasticizers evaluated in these formulations were Santicizer S-160 (butyl benzyl phthalate), Benzoflex 9-88 (dipropylene glycol dibenzoate), and DBEA (dibutoxy ethyl adipate).

The data for the outer skin formulations are more significant if the mole ratio of amine to isocyanate is used rather than parts/hundred, as given in Table I; and this information will be given in succeeding tables which list the data for the evaluated outer skin formulations unless otherwise noted. Mole ratio is defined as follows:

$$\text{Mole Ratio} = \frac{\text{Equivalent weight of Amine}}{\text{Equivalent weight of Isocyanate}}$$

where the equivalent weight is the molecular weight divided by the functionality which is usually 2.

$$\text{Equivalent Weight} = \frac{\text{Molecular Weight}}{\text{Functionality}}$$

The following formula gives the relationship between mole ratio, equivalent weight and parts/hundred (PHR).

$$\text{PHR} = \frac{\text{Equivalent weight of Amine} \times \text{Mole ratio} \times 100}{\text{Equivalent weight of isocyanate}}$$

The entire series of PI compounds was submitted for physical testing. The physical test data are listed in Table II and II A and illustrated in Figures 1 and 2. Stress-strain determinations were performed on outer skin samples approximately .025-inch thick using a Scott Tensile Machine and the observed values were reported in lbs./in.sq. according to standard ASTM procedures. Two types of tear tests were performed on the outer skin samples. The Travers Tear or Die C Tear is a standard tear test described in ASTM-D634-54. The trouser tear is a test developed at UniRoyal where a 1 x 4-inch sample is cut vertically down the center of the piece a distance of 1 inch measured from the top of the sample. The split ends are placed in separate jaws of a Scott Tensile Machine in much the same way one would place legs of a trouser in each jaw of the tensile machine and the force in lbs./in. to continue tearing the piece along the vertical axis is recorded.

Having outlined earlier in this section the desirable properties of an outer skin compound, and analyzing the data in Tables II and II A and Figures 1 and 2, compounds C, N, and O appear to have the best combination of high tensile, low modulus and high tear values.

Figure 3 shows that the physical properties obtained with Vibrathane B-602 are approximately equivalent to those obtained with Vibrathane B-605 when meta phenylene diamine is used as the curative (compound A vs. compound D); these two materials developed equivalent physical properties also when para phenylene diamine is used as the curative as shown by the comparison of compound B vs. compound E in the same figure. It is advantageous that equivalent physical properties can be obtained from either Vibrathane B-602 or Vibrathane B-605 because the difference in reactivity rates of the two materials makes each desirable in constructing particular parts of the boot. The Vibrathane B-605 is the quicker reacting material which makes it more suitable for the sprayed outer skin. The Vibrathane B-602 is the slower reacting material which is more desirable for the outsole and the foam insulation.

Table III is a compilation of initial outer skin formulations and those developed later; included in Table III A is a list of their preliminary physical properties. Table III A separates the outer skin formulations into classes of plasticizers evaluated with each curative. Table III lists all of the formulations in parts/hundred. These two tables were included to show how the selection of plasticizers for outer skin formulations was narrowed down to those which were subjected to extensive testing.

Table III A shows the results of evaluating Vibrathane B-602 and Vibrathane B-605 at different mole ratios with the following curatives: meta phenylene diamine (MPDA); para phenylene diamine (PPDA); and methylene dianiline (MDA). These basic formulations were further evaluated with varying level of plasticizer. The evaluated plasticizers were: butyl benzyl phthalate (S-160); Benzoflex 9-88 (9-88); dibutoxyethyl adipate (DBEA); dibutoxyethoxy ethyl adipate (TP-95); di-2-ethylhexyl azelate (DOZ); triethylene glycol dimethyl ether (E-181); and cresyl diphenyl phosphate (S-140).

The compounds in Table III A having low modulus, high tensile and tear and good low temperature properties were: compounds S, DII, and AII

TABLE II
TEAR TEST RESULTS

Compound	Formulation	(Die C)		Trousers Tear (PPI)	KEY:
		Graves Tear (PPI)	Tear (PPI)		
A	(602 + MPDA .85 MR)	416.2	10.5		- Vibrathane B-602
B	(602 + PPDA .85 MR)	558.1	20		- Vibrathane B-605
C	(602 + MDA .85 MR)	354.1	57.9		- Meta Phenylene Diamine
D	(605 + MPDA .85 MR)	490.2	45.2		- Para Phenylene Diamine
E	(605 + PPDA .85 MR)	611	16		- Methylene Dianiline
F	(605 + MDA .85 MR)	512	13.9		- 1,4-Butanediol
G	(605 + 1,4-BD + MPDA .9 MR)	129.1	30.5		- Butyl Benzyl Phthalate
H	(605 + 1,4-BD + PPDA .9 MR)	386.2	63.4		- Benzoflex 9-88
I	(605 + 1,4-BD + MDA .9 MR)	263	57.8		- Dibutoxyethyl Adipate
J	(605 + MPDA .95 MR)	354	10		- Mole Ratio
K	(605 + MDA .95 MR)	539.1	163		- Amine
L	(602 + MPDA .95 MR)	468	42.7		- X/100
M	(602 + PPDA .95 MR)	663.1	119.5		
N	(602 + MDA .95 MR)	357.2	40.2		
O	(605 + 1,4-BD + MPDA .9 MR 3/4 AM)	269.1	49.2		
P	(605 + 1,4-BD + MDA .9 MR 3/4 AM)	255	13.7		
Q	(605 + MPDA + S160 15/100 .95 MR)	238.2	53.3		
R	(605 + MDA + S160 15/100 .95 MR)	337.1	7.39		
S	(605 + MPDA + BF 15/100 .95 MR)	305.1	50		
T	(605 + MDA + BF 15/100 .95 MR)	371.1	132		
U	(605 + MDA + DBEA 15/100 .95 MR)	370.2	7.8		

(All compounds cured at 200°F for 1 hour)

TABLE II A
STRESS-STRAIN DATA

<u>Compound</u>	<u>Stress (psi) at Strain of</u> <u>100%</u>	<u>300%</u>	<u>Tensile</u> <u>Strength (psi)</u>	<u>% Elongation</u> <u>at Break</u>
A	639	1268	5853	460
B	800	1433	6353	510
C	364	738	5900	640
D	476	1618	6523	515
E	568	1541	7033	531
F	531	1315	7100	530
G	0	0	1166	922
H	341	755	3846	692
I	165	400	2720	820
J	432	1163	3120	432
K	470	950	4616	742
L	567	1046	7176	521
M	721	1245	8883	630
N	332	604	5000	522
O	190	594	5273	650
P	314	780	3106	441
Q	276	543	2386	761
R	348	921	1373	380
S	124	553	3103	712
T	362	692	2153	771
U	334	1000	4871	541

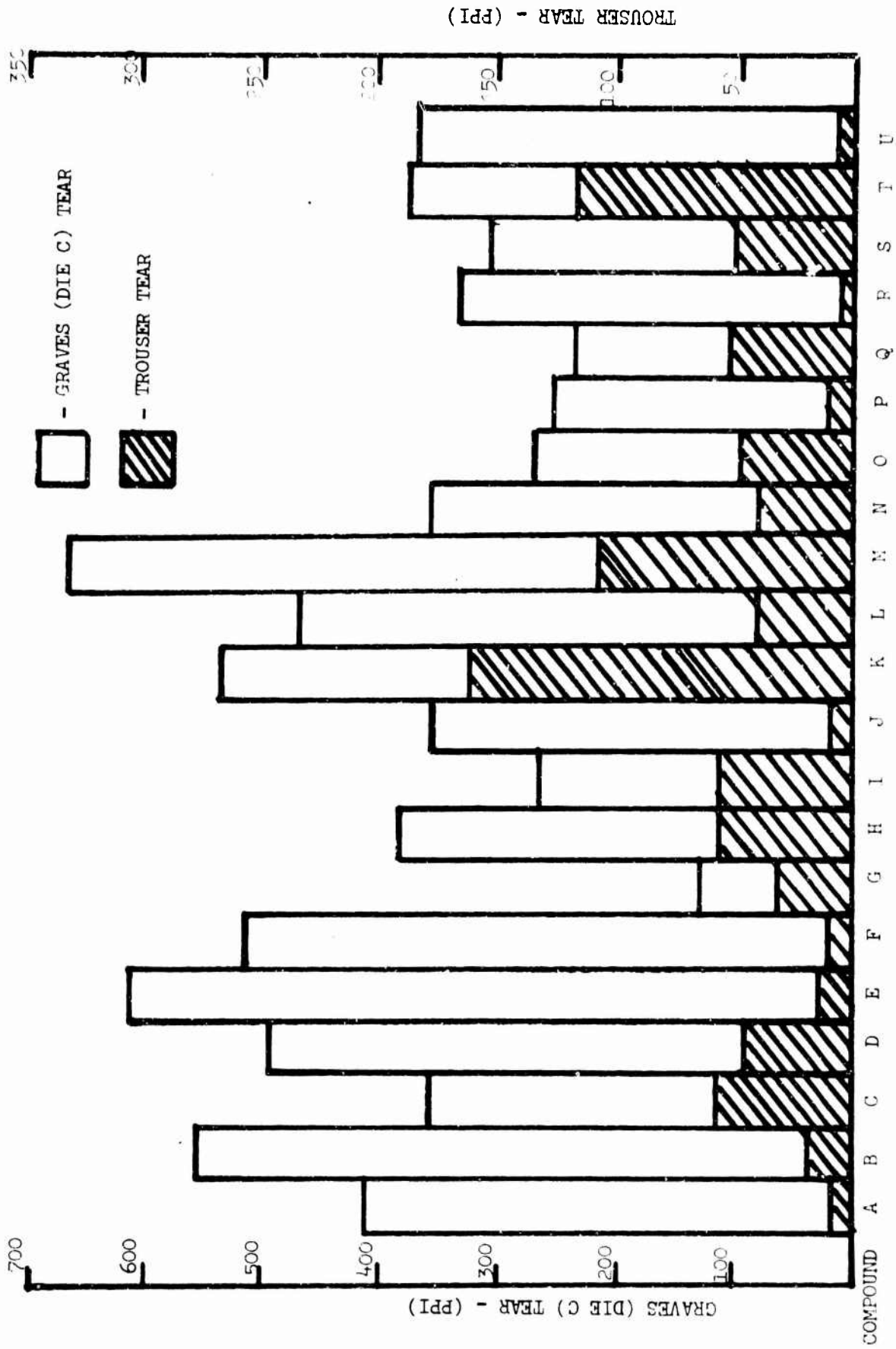

FIGURE 1
 TEAR TEST RESULTS

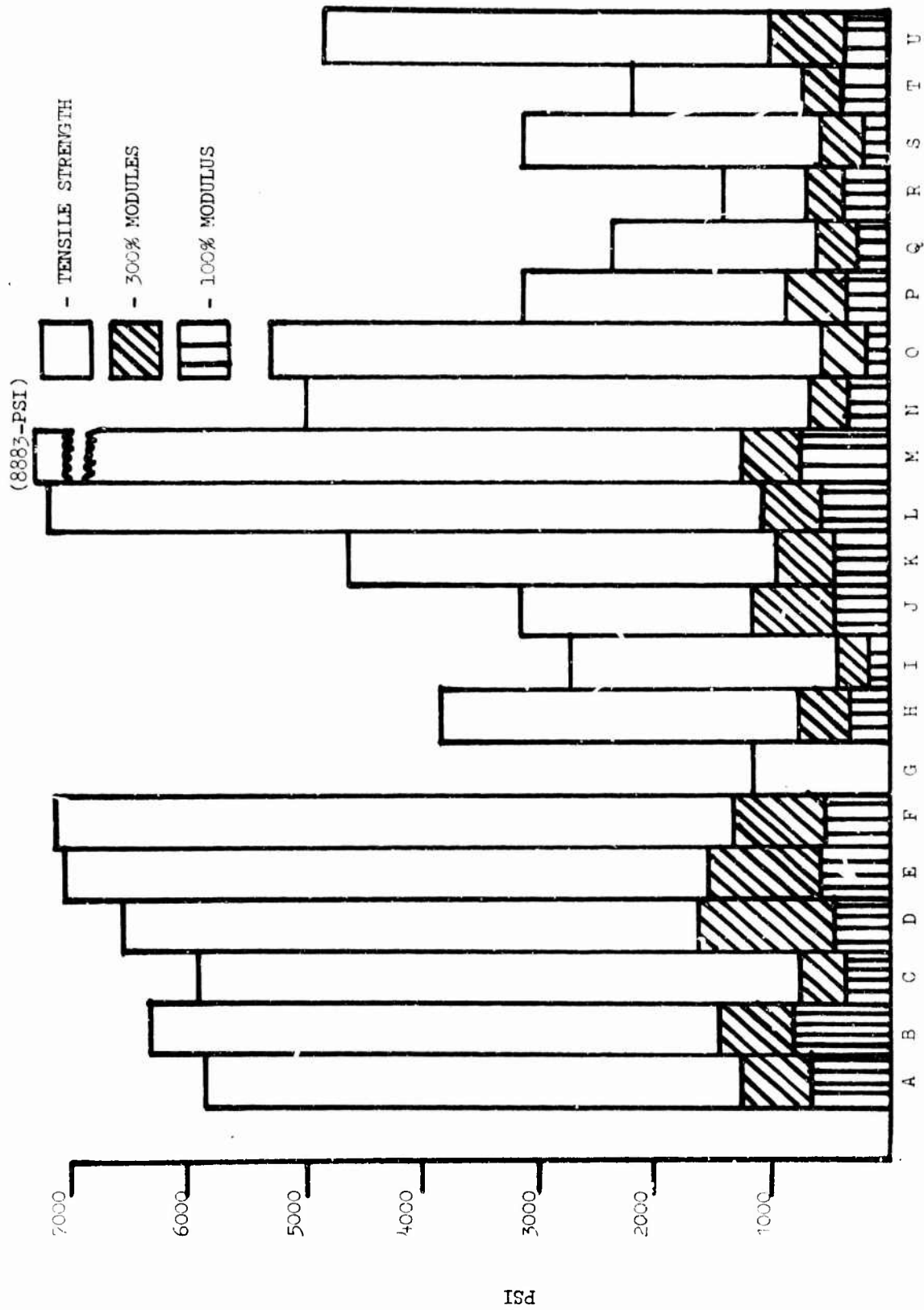

FIGURE 2
STRESS-STRAIN DATA

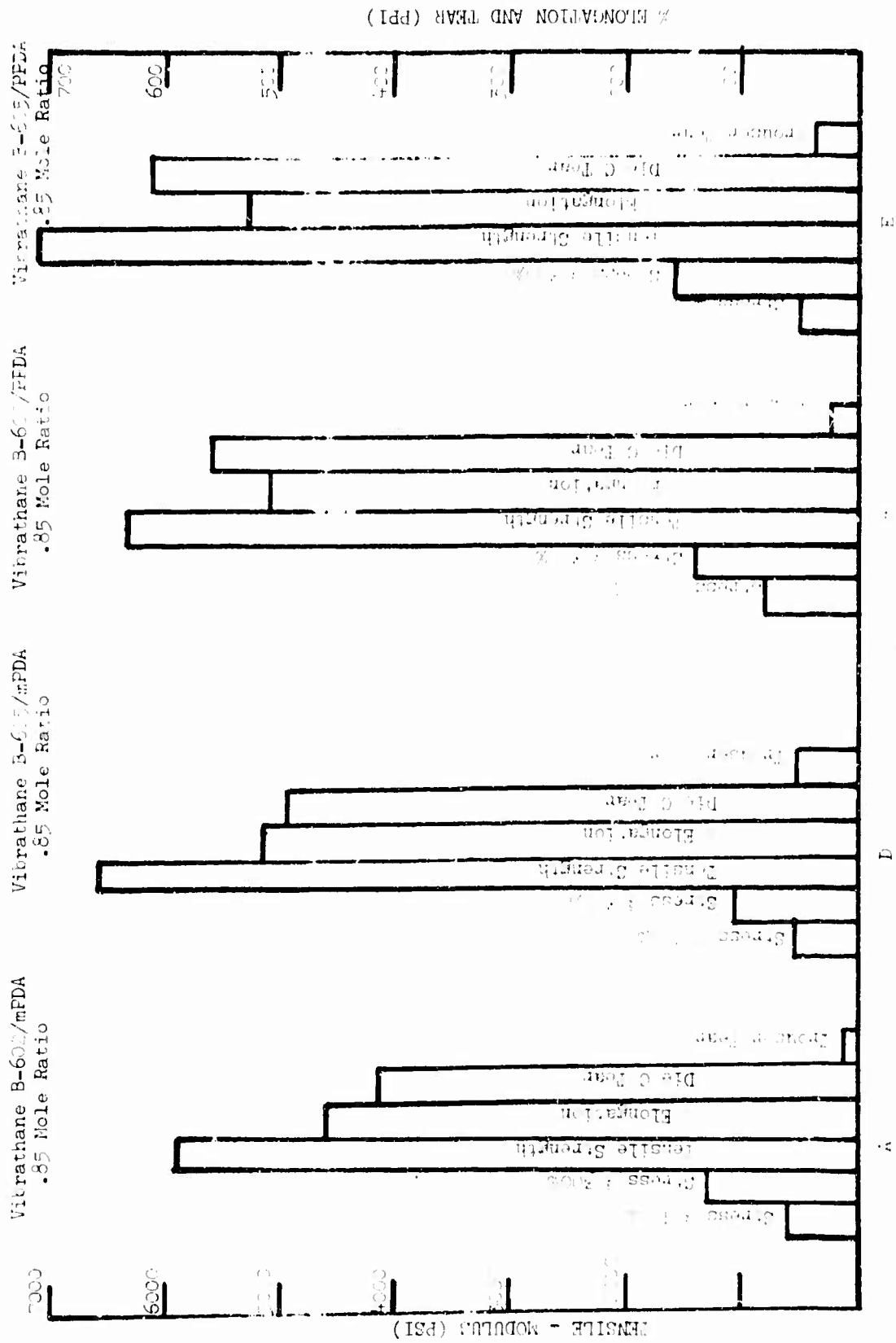

FIGURE 1
TENSILE AND TEAR PROPERTIES OF VIBRATHANE B-602/mPDA

TABLE VIII

OUTER SKIN FORMULATIONS (PARTS/HUNDRED)

	A	L	C	N	B	M	D	J	F	K	E	A-II
	100	100	100	100	100	100	100	100	100	100	100	100
B-602	-	-	-	-	-	-	-	-	-	-	-	-
B-605	3.6	4.0	-	-	-	-	100	100	100	100	100	-
MPDA	-	-	-	-	-	-	3.4	3.9	-	-	-	-
MDA	-	-	6.6	7.3	-	-	-	-	6.4	7.0	-	-
PPDA	-	-	-	-	3.6	4.0	-	-	-	-	3.4	-
B-605	J-II	G	O	L-II	I	P	K-II	H	Q	G-II	S	D-II
	100	100	100	100	100	100	100	100	100	100	100	100
MPDA	3.0	2.0	1.0	-	-	-	-	-	3.9	3.9	3.9	3.9
MDA	-	-	-	5.7	3.7	1.8	-	-	-	-	-	-
PPDA	-	-	-	-	-	-	3.0	2.0	-	-	-	-
BD	0.5	1.4	2.2	0.5	1.4	2.2	0.5	1.4	-	-	-	-
S-160	-	-	-	-	-	-	-	-	15	45	-	-
BF9-33	-	-	-	-	-	-	-	-	-	-	15	30
												45
B-605	D-III	A-IV	M-III	J-III	G-III	R	N-II	I-II	F	F-II	C-II	F-III
	100	100	100	100	100	100	100	100	100	100	100	100
MPDA	3.9	3.9	3.9	3.9	3.9	-	-	-	-	-	-	-
MDA	-	-	15	30	45	7.0	7.0	7.0	7.0	7.0	7.0	7.0
TP-95	-	-	-	-	-	-	-	-	-	-	-	-
DBEA	15	45	-	-	-	-	-	-	-	-	-	15
S-160	-	-	-	-	-	15	30	45	-	-	-	-
BF9-33	-	-	-	-	-	-	-	-	15	30	45	-
B-605	C-III	N-III	L-III	I-III	M-II	K-II	E-II	B-II	E-III	B-III	K-III	H-III
	100	100	100	100	100	100	100	100	100	100	100	100
MDA	7.0	7.0	7.0	7.0	-	-	-	-	-	-	-	-
PPDA	-	-	-	-	3.9	3.9	3.9	3.9	3.9	3.9	3.9	3.9
DBEA	45	-	-	-	-	-	-	-	15	15	-	-
TP-95	-	15	30	45	-	-	-	-	-	-	30	45
S-160	-	-	-	-	30	45	-	-	-	-	-	-
BF9-33	-	-	-	-	-	-	30	45	-	-	-	-
KEY:	602	Vibrathane B-602	MDA	Methylene Diamine	BD	1,4-Butanediol	BF 9-33	Benzoflex 9-33	DBEA	Dibutoxyethyl Acipate	TP-95	Dibutoxyethoxy Ethyl Acipate
	605	Vibrathane B-605	MDA	Methylene Diamine	S-160	Butyl Benzyl Phthalate	PPDA	Para Phenylene Diamine				
	MPDA	M-III	Methyl Methacrylate									
	N-III	N-III	N-III									
	L-III	L-III	L-III									
	I-III	I-III	I-III									
	M-II	M-II	M-II									
	K-II	K-II	K-II									
	E-II	E-II	E-II									
	B-II	B-II	B-II									
	E-III	E-III	E-III									
	B-III	B-III	B-III									
	K-III	K-III	K-III									
	H-III	H-III	H-III									

TABLE III A

OUTER SKIN FORMULATIONS AND PHYSICAL PROPERTIES

SAMPLE	POLYMER/CURATIVE/MR ^b	PLASTIZER - PHR	MODULUS (psi)		TENSILE STRENGTH (psi)	% ELONGATION	DIE C TEAR	TROUSER TEAR	FLEX @ -40°F*
			100%	300%					
A	(B602/MPDA/.85)	-	640	1250	5900	460	420	8	NC
L	(B602/MPDA/.95)	-	570	1050	7000	520	450	40	NC
C	(B602/MDA/.85)	-	360	670	6000	560	330	80	NC
N	(B602/MDA/.95)	-	330	660	6000	530	250	50	NC
B	(B602/PPDA/.85)	-	800	1450	6400	510	560	16	NC
M	(B602/PPDA/.95)	-	720	1250	9000	630	670	120	NC
D	(B605/MPDA/.85)	-	500	1300	6600	520	490	20	NC
J	(B605/MPDA/.95)	-	420	1200	4500	440	370	8	NC
F	(B605/MDA/.85)	-	540	1320	7000	530	520	15	NC
K	(B605/MDA/.95)	-	470	950	4600	740	530	200	NC
E	(B605/PPDA/.85)	-	560	1550	6700	530	615	10	NC
J-I	(B605/MPDA/.75)	BD ^a	210	450	850	880	200	20	C
G	(B605/MPDA/.50)	BD ^a	100	100	1150	930	140	30	C
O	(B605/MPDA/.25)	BD ^a	190	600	5300	650	390	50	C
L-II	(B605/MDA/.75)	BD ^a	400	950	6500	700	550	80	C
I	(B605/MDA/.50)	BD ^a	200	400	2800	820	260	60	C
P	(B605/MDA/.25)	BD ^a	370	300	3000	440	250	15	C
K-II	(B605/PPDA/.75)	BD ^a	420	1200	6200	830	730	105	C
H	(B605/PPDA/.50)	BD ^a	400	750	4000	710	400	80	C
Q	(B605/MPDA/.95)	S-160	280	550	2375	770	240	55	NC
G-II	(B605/MPDA/.95)	S-160	260	630	3480	550	240	7	NC
S	(B605/MPDA/.95)	9-28	90	555	3100	770	300	50	NC
D-II	(B605/MPDA/.95)	9-28	175	570	2590	720	395	22	NC
A-II	(B605/MPDA/.95)	9-28	230	615	4190	630	310	8	NC
D-III	(B605/MPDA/.95)	DBEA	460	980	1250	300	270	0	NC
A-IV	(B605/MPDA/.95)	TBEA	180	545	3045	650	240	18	NC

TABLE III A (Cont'd)

OUTER SKIN FORMULATIONS AND PHYSICAL PROPERTIES

SAMPLE	(POLYMER/CURATIVE/MRO)	PLASTICIZER - PHR	MODULUS (PST)		TENSILE STRENGTH (PST)	% ELONGATION	DIE C	TROUSER FLEX	
			100%	300%					WEAR TEAR
M-III	(B605/MPDA/.95)	15	525	660	6590	780	560	120	NC
J-III	(B605/MPDA/.95)	30	285	575	2125	700	300	60	NC
G-II	(B605/MPDA/.95)	45	215	385	1010	790	170	30	NC
R	(B605/MDA/.95)	15	350	920	1400	320	330	2.5	NC
N-II	(B605/MDA/.95)	30	275	610	2990	690	270	40	NC
I-II	(B605/MDA/.95)	45	255	605	3170	720	340	50	NC
T	(B605/MDA/.95)	15	355	695	2130	720	350	130	NC
F-II	(B605/MDA/.95)	30	320	680	4130	760	330	60	NC
C-II	(B605/MDA/.95)	45	235	660	3360	720	330	45	NC
F-III	(B605/MDA/.95)	15	261	261	360	350	124	10	NC
U	(B605/MDA/.95)	15	330	1000	4800	520	370	55	NC
C-III	(B605/MDA/.95)	45	180	545	3045	660	290	0	NC
N-III	(B605/MDA/.95)	15	500	900	4500	710	520	90	NC
L-III	(B605/MDA/.95)	30	325	610	2885	760	340	90	NC
I-III	(B605/MDA/.95)	45	335	690	2700	650	375	155	NC
M-II	(B605/PPDA/.95)	30	255	520	1735	665	335	70	NC
H-II	(B605/PPDA/.95)	45	150	390	945	770	180	40	NC
B-II	(B605/PPDA/.95)	45	235	695	3375	650	370	15	NC
E-II	(B605/PPDA/.95)	30	320	855	3350	630	425	16	NC
E-III	(B605/PPDA/.95)	15	390	755	3400	940	430	30	NC
E-III	(B605/PPDA/.95)	45	440	1220	3900	470	560	55	NC
K-III	(B605/PPDA/.95)	30	420	720	3565	760	475	245	NC
K-III	(B605/PPDA/.95)	45	375	715	2785	755	400	145	NC

* Curative #2 * PDA ratio (NR) * NC - No cracking after 100,000 flexes. C- Cracking after 100,000 flexes.

(benzoflex 9-88 series); compounds DIII and AIV (DBEA series); and compounds Q and GII (S-160 series). The .95 mole ratio was best for low modulus and good tear values. Meta phenylene diamine (mPDA) was the best curative for low modulus and high elongation.

The low temperature flexibility tester, built by UniRoyal, and operable in a cold box at -40°F , consists of a motor driven moveable jaw that moves in a reciprocating, horizontal motion towards a stationary jaw at a rate of about 300 cycles/min. The distance between the stationary and reciprocating jaw varies from 1/8-inch to 1-5/8-inches with each cycle. One end of a 1 x 4-inch sample is clamped in the reciprocating jaw and the other end in the stationary jaw; the sample is made to bend and flex once each cycle when the machine is running. The sample is inspected periodically and the number of flexes at which it begins to crack is recorded.

The initial good low temperature flexibility noted with the cited plasticizers led to the formulation of three samples (AI, AIII, and OIII) which are listed in Table IV. These three outer skin samples were submitted to the U. S. Army Natick Laboratories for Gehman Tests (ASTM D-1053). The data listed in Table IV indicate that sample AI and sample AIII have low temperature flexibility considered more than adequate for the lightweight insulated boot.

A final group of outer skin formulations containing curatives, plasticizers and mole ratio which showed promise of giving the best overall properties were formulated and are numbered 1-9 in Table V. These selected formulations were subjected to extensive testing as shown in Tables V A through V C.

In general, aged tensile decreased over unaged tensile whereas the elongation and tear remained about the same after aging.

Fadeometer aging deteriorates the samples more than oven aging; however, the samples were not pigmented. The percent volume change and percent weight change in ASTM oils No. 1 and No. 3 were excellent for all samples; these values are comparable to those obtained with oil resistant rubbers like the Nitriles.

Table V C shows the results of a skin puncture test on the nine samples tested. This test was developed by modifying Federal Test Method Standard Number 311, Method 2051. The modified test records the force required to puncture a skin sample stretched across a 2-inch diameter pipe with a 1/8-inch diameter rounded rod using an Instron testing machine. A comparison was made between the pounds to puncture a 50 mil thick sample (puncture test) and the toughness (product of tensile X elongation). The toughness measurements cannot be used as absolute values but rather as relative values related only to polyurethane, outer skin formulations because of insufficient data to establish other relationships. Figure 4 shows that there is a direct straight-line relationship between puncture resistance and tensile, and puncture resistance and toughness. These illustrations facilitate compound comparisons and show that puncture resistance can be determined from stress/strain measurements (Figure 4).

TABLE IV

SELECTED OUTER SKIN FORMULATIONS

<u>Composition of Samples (PIR)</u>	<u>Sample A-1</u>	<u>Sample A-11</u>	<u>Sample C-111</u>
Vibrathane B-602	100	100	100
Meta Phenylene Diamine (MPDA)	4 (.95 Mole Ratio)	4 (.95 Mole Ratio)	4 (.95 Mole Ratio)
Benzoflex 9-28	36	-	-
Dibutoxyethyl Adipate (DBEA)	-	36	-
Triethylene Glycol Dimethyl Ether (E-161)	-	-	36
<u>Physical Properties</u>			
100% Modulus (PSI)	380	360	330
300% Modulus (PSI)	650	590	550
Tensile Strength (PSI)	1800	1600	1500
% Elongation	590	610	660
Tear - Die C (PPI)	330	270	360
Tear - Trouser (PPI)	50	90	100
Flex @-40°F (After 100,000 flexes)	No Cracking	No Cracking	No Cracking
<u>Gehman Data</u>			
T ₂	Trial #1	Trial #2	Trial #1
T ₅	-68.8°F	-69.7°F	+7.7°F
T ₁₀	-78.7°F	-80.5°F	+43.6°F
T ₁₀₀	-81.4°F	-85.0°F	-90.4°F
T ₁₀₀	-94.0°F	-93.1°F	-94.0°F
			+23.0°F
			-15.7°F
			-51.9°F
			-94.0°F
			+23.0°F
			-12.1°F
			-56.6°F
			-34.0°F

TABLE V

PHYSICAL PROPERTIES OF OUTER SKIN FORMULATIONS

Outer Skin Formulations	100% Modulus (PSI)			200% Modulus (PSI)			Tensile (PSI)			% Elongation		
	Un-Aged	Heat Aged ^a	Fade Aged ^b	Un-Aged	Heat Aged ^a	Fade Aged ^b	Un-Aged	Heat Aged ^a	Fade Aged ^b	Un-Aged	Heat Aged ^a	Fade Aged ^b
#1 B-605/.95MR mPDA/ S-160 (45 PHR)	490	230 (-53%)	-	710	500 (-30%)	-	5780	2610 (-55%)	100	830	760 (-8%)	10
#2 B-605/.95MR MDA/ S-160 (45 PHR)	590	290 (-51%)	-	840	600 (-29%)	-	3880	2580 (-33%)	140	500	610 (+22%)	20
#3 B-605/.85MR MDA/ BF9-88 (45 PHR)	600	250 (-58%)	-	820	500 (-39%)	-	4830	2430 (-50%)	100	640	700 (+9%)	0
#4 B-605/.95 MR MDA/ BF9-88 (45 PHR)	510	250 (-51%)	-	720	490 (-32%)	-	6000+	2610 (-57%)	240	730	710 (-3%)	100
#5 B-605/.95 MR mPDA/ DBEA (40 PHR)	440	290 (-34%)	270	590	500 (-15%)	-	3180	2200 (-31%)	320	790	710 (-10%)	190
#6 B-605/.95MR mPDA/ S-140 (45 PHR)	360	200 (-45%)	-	510	450 (-12%)	-	4130	2000 (-52%)	180	650	620 (-5%)	90
#7 B-605/.95MR mPDA/ E-181 (40 PHR)	410	380 (-7%)	690	590	690 (-17%)	-	6650	2730 (-59%)	740	680	580 (-15%)	150
#8 B-605/.95MR mPDA/ S-140 (40 PHR)	370	210 (-43%)	-	520	480 (-8%)	-	4430	2210 (-50%)	250	660	620 (-6%)	80
#9 B-605/.95MR mPDA/ DOX (40 PHR)	370	220 (-41%)	490	480	450 (-6%)	-	1670	1210 (-28%)	670	630	610 (-3%)	250

a - Aged for 72 Hours @ 212°F
 KEY: B-602 - Vibrathane B-602
 MDA - Methylene Dianiline
 BF9-88 - Benzoflex 9-88
 BOX - Di-2-ethylhexyl Azelate

b - Aged for 168 Hours in Fadeometer
 B-605 - Vibrathane B-605
 S-140 - Cresyl Diphenyl Phosphate
 DBEA - Dibutyl-ethylene Adipate
 mPDA - Meta Pherylene Diamine
 S-160 - Butyl Benzyl Phthalate
 E-181 Triethylene Glycol
 Dimethyl Ether

TABLE V A

PHYSICAL PROPERTIES OF OUTER SKIN FORMULATIONS

Outer Skin Formulations	Tear - Die C (FPI)		Tear - Trouser (PPI)		Tear - Shirt A	
	Heat Fade		Heat Fade		Heat Fade	
	Unaged	Aged ^a	Unaged	Aged ^b	Unaged	Aged ^b
#1 B-605/.95MR mPDA/S-160 (45 PHR)	550	500 (-9%)	70	80	60	67
#2 B-605/.95MR MDA/S-160 (45 PHR)	450	420 (-7%)	40	60	66	74
#3 B-605/.85MR MDA/BF9-88 (45 PHR)	450	440 (-2%)	70	70	66	73
#4 B-605/.5MR MDA/BF9-88 (45 PHR)	460	450 (-2%)	60	50	62	71
#5 B-605/.95MR mPDA/DBEA (40 PHR)	380	400 (+5%)	60	80	61	72
#6 B-605/.95MR mPDA/S-140 (45 PHR)	350	380 (-9%)	40	40	59	63
#7 B-605/.95MR mPDA/E - 181 (40 PHR)	480	410 (-15%)	40	90	60	76
#8 B-605/.95MR mPDA/S-140 (40 PHR)	330	390 (-18%)	50	60	60	70
#9 B-605/.95MR mPDA/DOZ (40 PHR)	260	350 (+27%)	50	60	58	70

a - Aged for 70 hours @ 212°F

b - Aged for 168 hours in Fadeometer

TABLE V B

PHYSICAL PROPERTIES OF OUTER SKIN FORMULATIONS

	After 70 Hours @212°F in Oil #3			After 70 Hours @212°F in Oil #1			Gehman Stiffness - ASTM 1053		
	%Volume Change	%Weight Change	%Volume Change	%Volume Change	%Weight Change	T ₂	T ₅	T ₁₀	T ₁₀₀
#1 B-605/.95 MR mPDA/S-160 (45 PHR)	+23.67	+16.24	-18.83	-21.46	+19.40°F	-14.80°F	-41.30°F	-81.40°F	
#2 B-605/.95 MR MDA/S-160 (45 PHR)	+13.54	+ 7.91	-18.34	-20.53	+19.40°F	- 7.60°F	-23.80°F	-79.60°F	
#3 B-605/.85MR MDA/BF9-88 (45 PHR)	+15.73	+ 9.25	-18.70	-21.60	- 9.40°F	-43.60°F	-59.80°F	-88.60°F	
#4 B-605/.95MR MDA/BF9-88 (45 PHR)	+20.20	+12.77	- 8.86	-13.21	+26.60°F	+ 8.60°F	-20.20°F	-79.60°F	
#5 B-605/.95MR mPDA/DBEA (40 PHR)	+16.03	+12.93	-21.56	-21.17	+24.80°F	-20.20°F	-56.20°F	-99.40°F	
#6 B-605/.95MR mPDA/S-140 (45 PHR)	+ 6.11	+ 3.67	-20.70	-24.29	+ 5.80°F	-56.20°F	-74.20°F	-99.40°F	
#7 B-605/.95MR mPDA/E - 181 (40 PHR)	+29.75	+25.57	- 8.65	- 9.53	+19.40°F	+ 8.60°F	-23.80°F	-95.80°F	
#8 B-605/.95MR mPDA/S-140 (40 PHR)	+13.78	+ 6.20	-23.77	-22.61	+10.40°F	-38.20°F	-67.00°F	-99.40°F	
#9 B-605/.95MR mPDA/DOZ (40 PHR)	+10.84	+10.26	-25.85	-23.50	+15.30°F	- 5.80°F	-49.00°F	-99.40°F	

TABLE V C

PHYSICAL PROPERTIES OF OUTER SKIN FORMULATIONS

Outer Skin Formulations	Tensile Strength (PSI)	% Elongation	Toughness (Tensile X Elongation)	Puncture Resistance Test			
				1/8" Dia. Rod (lbs.*)	1/8" Sample Thick-ness (Mils)	1/8" Dia. Rod (lbs.*)	Sample Thick-ness (Mils)
#1 B-605/.95MR mPDA/S-160 (45 PHR)	5780	830	4.80X10 ⁶	23	25	46	No Break
#2 B-605/.95MR MDA/S-160 (45 PHR)	3880	500	1.94X10 ⁶	23	38	30	66
#3 B-605/.85MR MDA/BF9-88 (45 PHR)	4830	640	3.09X10 ⁶	26.5	32	41	81
#4 B-605/.95MR MDA/BF9-88 (45 PHR)	6000	730	4.38X10 ⁶	33	37	45	100
#5 B-605/.95MR mPDA/DREA (40 PHR)	3180	790	2.52X10 ⁶	16	30	27	45
#6 B-605/.95MR mPDA/S-140 (45 PHR)	4130	650	2.68X10 ⁶	16	22	36	47
#7 B-605/.95MR mPDA/E - 181 (40 PHR)	6650	680	4.52X10 ⁶	29	28	52	-
#8 B-605/.95MR mPDA/S-140 (40 PHR)	4430	660	2.93X10 ⁶	19	24	40	-
#9 B-605/.95MR mPDA/DOZ (40 PHR)	1670	630	1.05X10 ⁶	25.5	35	36	-

*Force to Puncture Sample

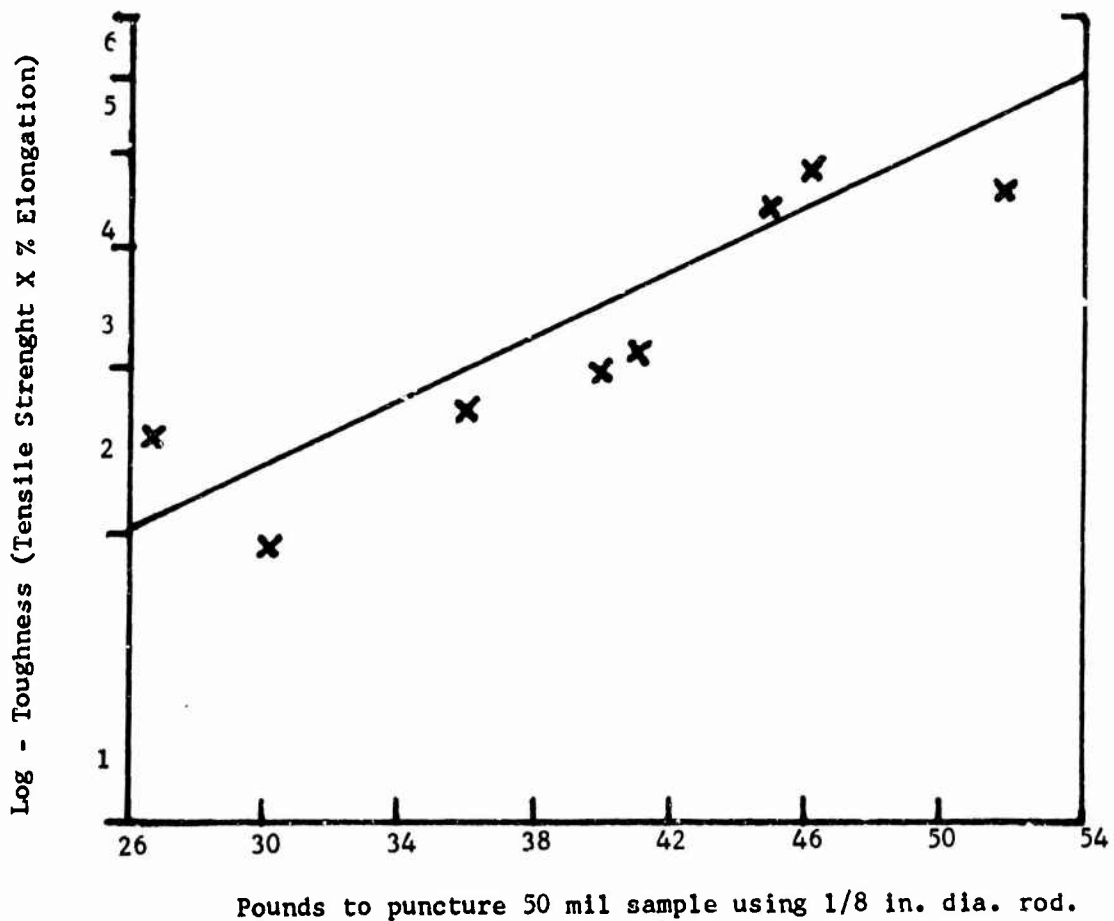
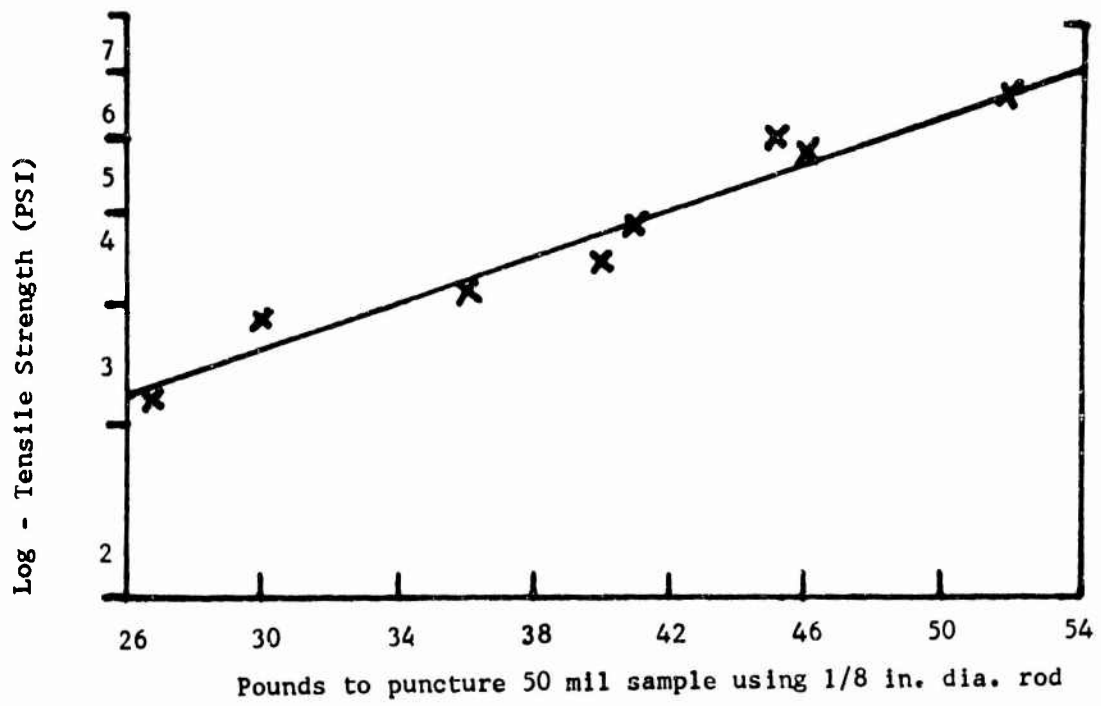

FIGURE 4
 PUNCTURE RESISTANCE VS. TENSILE STRENGTH VS. TOUGHNESS

Figures 4 and 5 A show that toughness (tensile X elongation) does not diminish with the addition of plasticizer to any one of the nine samples. The dotted line traces the values for the formulation without plasticizer, and the solid line traces the values for the same formulation with plasticizer. The toughness is directly related to the area under the curve.

The objectives for low modulus, high tensile, good puncture resistance and low temperature flexibility were generally met by a number of outer skin formulations. Basically, these outer skin formulations consisted of Vibrathane B-605 cured with either MDA or MDI and plasticized with 40 to 45 parts/hundred of either Benzoflex 9-88, Santicizer S-140 or Santicizer S-160. Careful analysis of the data, especially Gehman stiffness, led to the selection of the following formulation for use as the outer skin compound.

<u>Ingredient</u>	<u>PHR</u>
Vibrathane B-605	100
Toluene	200
mPDA	3.8
THF	51.2
Santicizer S-140	40
3041 Black	5

The above outer skin compound was compared to a natural rubber skin currently used on the standard government cold weather boot. Table V D lists the comparison. The tensile strength of the polyurethane skin compound is greater than the tensile strength of the rubber skin compound and the elongation of the polyurethane skin compound is greater than the elongation for the rubber skin compound. Both the Die C tear and the Trouser Tear values are greater for the polyurethane skin compound than for the rubber skin compound. The toughness (tensile X elongation) which was demonstrated to be a function of the puncture resistance is greater for the polyurethane skin than for the rubber skin. These data indicate that an outer skin comparable to natural rubber can be made from polyurethane.

Low temperature, Gehman stiffness measurements show that the rubber outer skin has better low temperature flexibility than the polyurethane outer skin. However, the low temperature flexibility for the polyurethane outer skin was considered adequate. Figure 6 graphically illustrates the toughness curve where the area under the curve is directly related to the toughness for the rubber skin sample.

The outer skin formulations listed in Table V were aged for 3 months in environmental chambers at the U. S. Army Natick Laboratories. The two aging chambers used were the Moderate Desert Chamber and the Moist Tropical Chamber. Table VI describes the environmental conditions of these chambers in a 24-hour cycle. The results of the stress-strain data for these aged outer skin samples are tabulated in Table VII and indicate very little deterioration of physical properties.

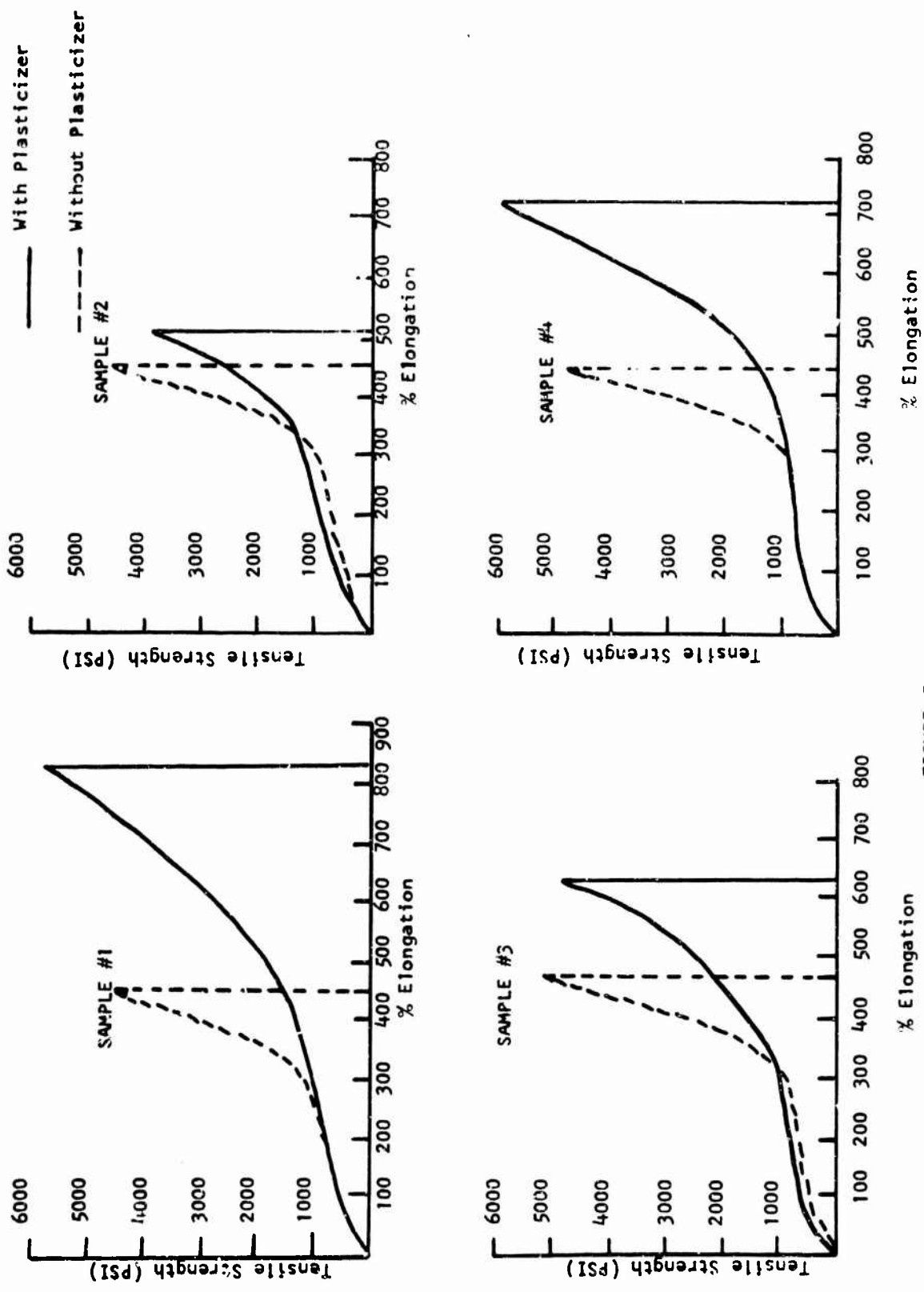

FIGURE 5
TOUGHNESS OF OUTER SKIN FORMULATIONS

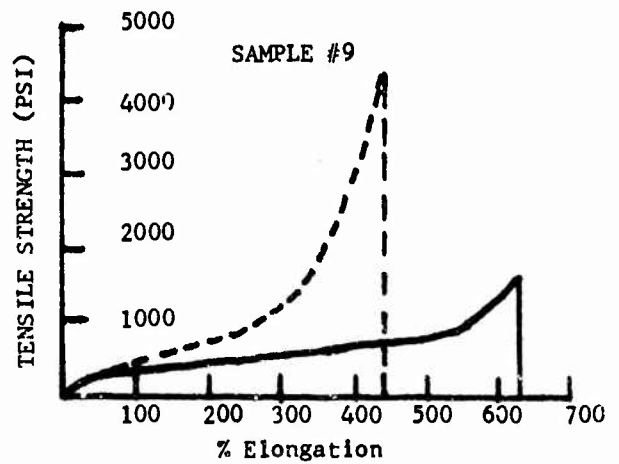
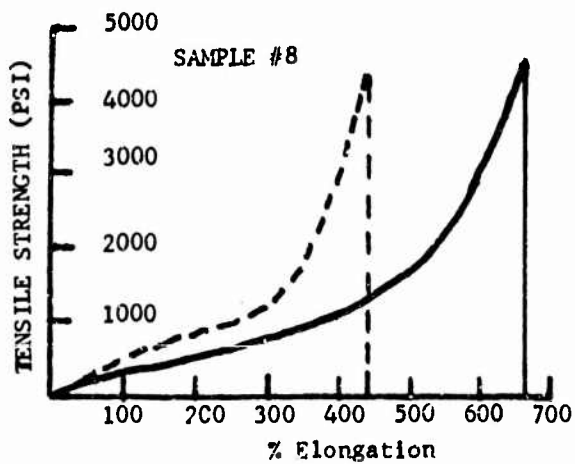
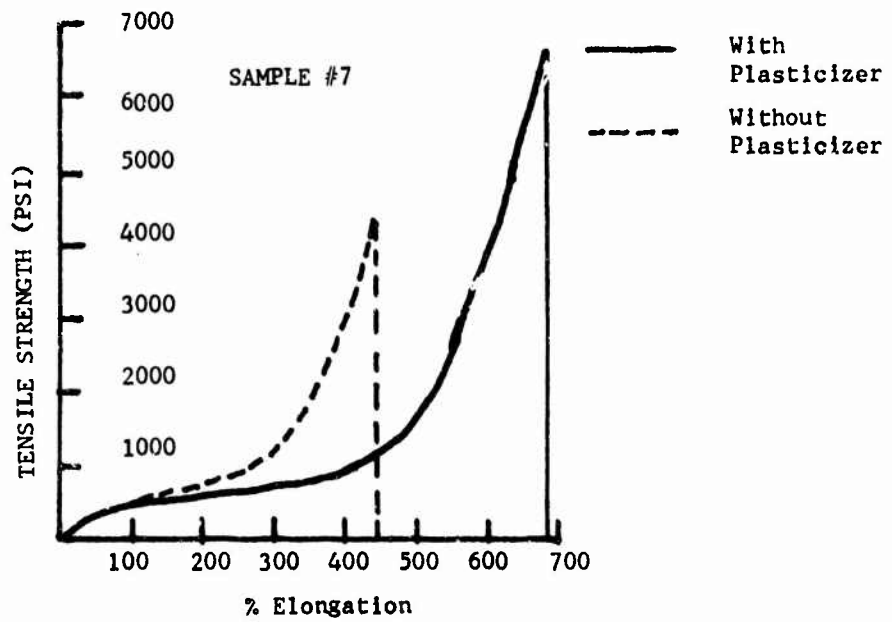
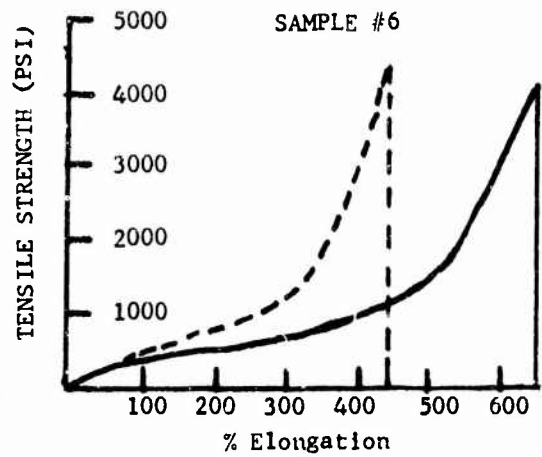
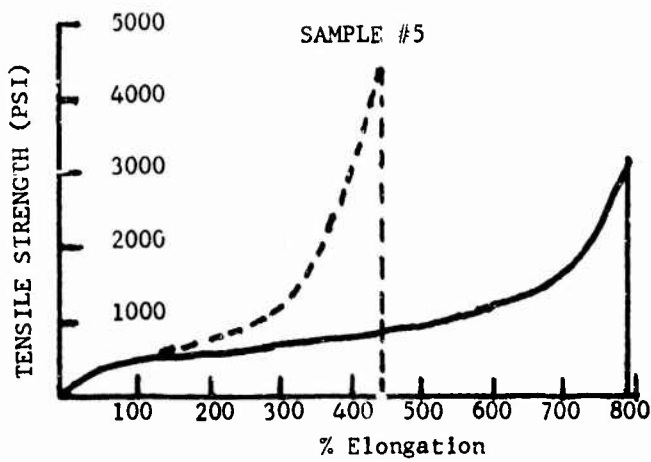

FIGURE 5A
TOUGHNESS OF OUTER SKIN FORMULATIONS

TABLE V D
COMPARISON OF PROPERTIES OF OUTER SKINS

	<u>Compounded Rubber Skin (On Standard Boots)</u>	<u>Sprayed Polyurethar Skin* (On . . . Prototype Pairs)</u>
<u>Physical Properties</u>		
100% Modulus (PSI)	132	360
300% Modulus (PSI)	633	800
Tensile Strength (PSI)	2477	2840
Elongation (%)	510	570
Trouser Tear (PPI)	-	22
Die C Tear (PPI)	214	320
Toughness (TXE)	1.26×10^6	1.62×10^6
Puncture Test ($\frac{1}{2}$ " Rod)	35 lbs./50 Mils	47 lbs./50 Mils
<u>Gehman Test Data:</u>		
T ₂	-68°F	+9°F
T ₅	-71°F	-39°F
T ₁₀	-73°F	-67°F
T ₁₀₀	-82°F	-100°F

*Formulation on preceding page - Page 20.

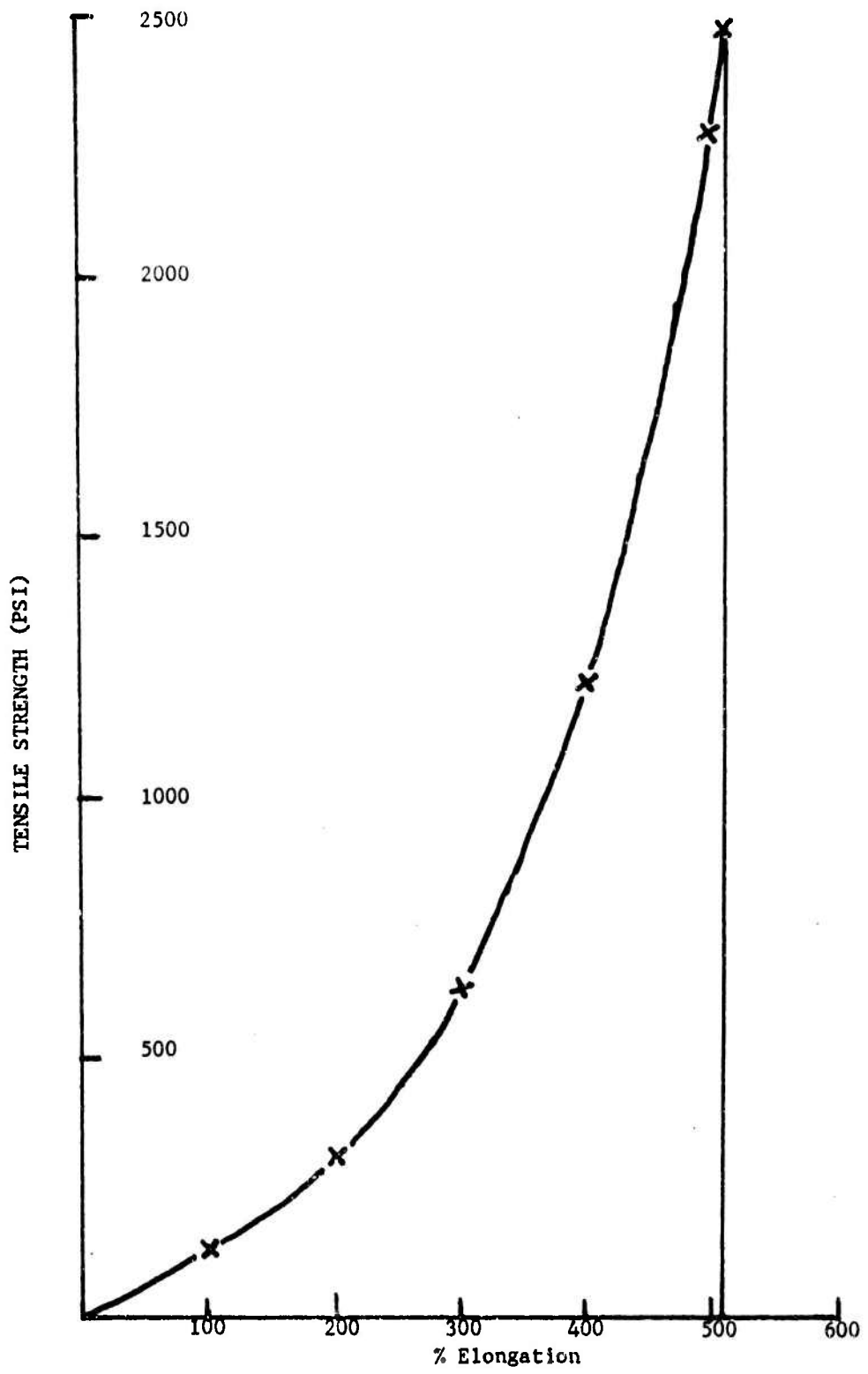

FIGURE 6
TOUGHNESS CURVE FOR NATURAL RUBBER OUTER SKIN

TABLE VII

PHYSICAL PROPERTIES OF AGED OUTER SKIN FORMULATIONS

Outer Skin Formulations	100% Modulus (PSI)						50% Modulus (PSI)		
	Utr- Aged	Deser Aged	Tropical Aged	Heat Aged	Fade- ometer Aged	Utr- Aged	Desert Aged	Tropical Aged	Heat Aged
#1 B-605/.95MR mPDA/ S-160 (45 PHR)	430	380 (-12%)	320 (-25%)	230 (-53%)	-	710	690 (-3%)	520 (-27%)	470 (-34%)
#2 B-605/.95MR MDA/ S-160 (45 PHR)	590	440 (-25%)	420 (-29%)	290 (-51%)	-	840	630 (-25%)	640 (-24%)	610 (-27%)
#3 B-605/.95MR MDA/ BF9-36 (45 PHR)	600	460 (-23%)	470 (-22%)	250 (-58%)	-	820	640 (-22%)	630 (-23%)	500 (-39%)
#4 B-605/.95MR MDA/ BF9-36 (45 PHR)	510	420 (-18%)	380 (-25%)	250 (-51%)	-	720	620 (-14%)	580 (-19%)	490 (-31%)
#5 B-605/.95MR mPDA/ DBEA (40 PHR)	440	360 (-18%)	370 (-16%)	290 (-34%)	270 (-39%)	590	560 (-5%)	570 (-3%)	500 (-15%)
#6 B-605/.95MR mPDA/ S-140 (45 PHR)	360	330 (-8%)	320 (-11%)	200 (-45%)	-	510	520 (2%)	430 (-16%)	450 (-12%)

Heat Aged
 Fadeometer Aged
 Desert Aged
 Tropical Aged

70 hours @ 212°F
 168 hours Fadeometer
 3 months Moderate Desert Chamber
 3 months Moist Tropical Chamber

TABLE VII (cont'd)

PHYSICAL PROPERTIES OF AGED OUTER SKIN FORMULATIONS

Outer Skin Formulations	Tensile Strength (PSI)				Percent Elongation (%)				Fade-ometer Aged	
	Un-Aged	Desert Aged	Tropical Aged	Heat Aged	Fade-ometer Aged	Un-Aged	Desert Aged	Tropical Aged		Heat Aged
#1 B-605/.95MR mPDA/ S-160 (45 PHR)	5780	4900 (-15%)	4910 (-15%)	2610 (-55%)	100	830	790 (-5%)	800 (-4%)	760 (-5%)	10
#2 B-605/.95 MR MDA/ S-160 (45 PHR)	3880	5710 (+48%)	4930 (+27%)	2580 (-33%)	140	500	720 (+44%)	690 (+38%)	610 (+22%)	20
#3 B-605/.85MR MDA/ BF9-88 (45 PHR)	4830	5230 (+8%)	4990 (+3%)	2430 (-50%)	100	640	650 (+2%)	660 (+3%)	700 (+9%)	0
#4 B-605/.15MR MDA/ BF9-88 (45 PHR)	6000	5010 (-16%)	4210 (-30%)	2610 (-57%)	240	730	720 (-1%)	710 (-3%)	710 (-3%)	100
#5 B-605/.95MR mPDA/ DBEA (40 PHR)	3180	4260 (+34%)	4260 (+34%)	2300 (-31%)	380	790	640 (-19%)	630 (-20%)	710 (-10%)	190
#6 B-605/.95MR mPDA/ S-140 (45 PHR)	4130	4220 (+2%)	4510 (+9%)	2000 (-52%)	180	650	650 (0%)	680 (+5%)	620 (-5%)	90

TABLE VII (cont'd)

PHYSICAL PROPERTIES OF AGED OUTER SKIN FORMULATIONS

Outer Skin Formulations	U ₁ -Aged	Tear - Die C (PPI)			Heat Aged	Fade-ometer Aged	U ₂ -Aged	Tear - Trooper (PPI)			Fade-ometer Aged
		Desert Aged	Tropical Aged	(%)				Desert Aged	Tropical Aged	(%)	
#1 B-605/.95MR mPDA/ S-160 (4.5 PHR)	550	430 (-22%)	450 (-18%)	500 (-9%)	30	70	100	110	80	10	
#2 B-605/.95MR MDA/ S-160 (4.5 PHR)	450	425 (-6%)	450 (-0%)	420 (-7%)	30	40	70	110	60	10	
#3 B-605/.85MR MDA/ PF9-88 (4.5 PHR)	450	435 (-3%)	445 (-1%)	440 (-2%)	10	70	35	70	70	10	
#4 B-605/.95MR MDA/ BF9-88 (4.5 PHR)	460	445 (-3%)	445 (-3%)	450 (-2%)	60	60	60	75	50	30	
#5 B-605/.95MR mPDA/ D5EA (4.0 PHR)	380	340 (-10%)	370 (-3%)	400 (+5%)	110	60	25	35	50	40	
#6 B-605/.95MR mPDA/ S-140 (4.5 PHR)	350	350 (0%)	390 (+10%)	380 (+9%)	60	40	20	50	40	40	

Stress, strain and tear data are reported in Table VIII for the same six skin samples which were aged in the environmental chambers for six months. Sample No. 6 is very similar to the selected outer skin formulation; the only difference is that it contains five more PHR of Santicizer S-140 plasticizer. When the aging of the skin samples was initiated, the final outer skin formulation was not finalized; therefore, the outer skin sample selected for aging was not identical in composition to the selected skin formulation. However, sample No. 6 closely approximates our formulation so that the data can be extracted and applied to the recommended formulation. The moderate desert chamber intermittently exposed the samples to extreme temperatures of 130°F., whereas, the moist tropical chamber intermittently exposed the samples to relative humidities as high as 96%. Examination of the data for a sample in each chamber showed that very little deterioration had taken place due to extremes of heat and moisture over a six-month period.

2. Outsole and Upper Insulation

All of the selected desirable compounds obtained from the evaluation of the outer skin formulations served as a starting point for the preparation of a foam insulation compound. These foam compounds were evaluated in much the same way that the outer skin compounds were evaluated.

The starting formulation for the outsole compound is shown below. Compounds were prepared by mixing together three masterbatches. Masterbatch one (MB 1) consists of 100 parts of Vibrathane B-602 and 2 parts of Silicone Surfactant SF-1079. MB2 is a mixture of 3 parts of Plasticizer S-160 to 1 part of Meta phenylene diamine. MB 3 is a 50/50 weight ratio of Nitrosan and Plasticizer S-140. The outsole compounds were obtained by mixing 102 parts of MB 1 with 12.56 parts of MB2 and a variable amount of MB 3 to give us compounds containing from 1 to 11 parts of Nitrosan. The ratio of MB 1 and MB 2 was kept constant in all of the outsole compounds evaluated.

STARTING FORMULATION (PHR)

Masterbatch #1	
Vibrathane B-602	100
SF 1079 Silicone	2
Masterbatch #2	
mPDA	3.14
Santicizer S-160	9.42
Masterbatch #3	
Nitrosan	50
Santicizer S-140	50

TABLE VIII

PHYSICAL PROPERTIES OF OUTER SKIN FORMULATIONS AGED SIX MONTHS

Outer Skin Formulations	100% Modulus (PSI)		Tensile Strength (PSI)		% Elongation		Tear-Die C (PPI)		Tear-Die D (PPI)
	Desert Aged	Tropical Aged	Desert Aged	Tropical Aged	Desert Aged	Tropical Aged	Desert Aged	Tropical Aged	
#1 B-605/.95MR mPDA/ S-160 (45 PHR)	270 (-45%)	260 (-47%)	4640 (-20%)	4710 (-18%)	780 (-6%)	780 (-6%)	430 (-2%)	450 (-13%)	110 (-2%)
#2 B-605/.95MR MDA/ S-160 (45 PHR)	360 (-39%)	340 (-42%)	5330 (+29%)	4910 (+27%)	710 (+42%)	700 (+40%)	460 (+7%)	460 (+2%)	95 (-6%)
#3 B-605/.85MR MDA/ BF9-33 (45 PHR)	380 (-37%)	420 (-43%)	4850 (NC)	4810 (NC)	650 (+2%)	660 (+3%)	450 (NC)	450 (NC)	40 (-5%)
#4 B-605/.95MR MDA/ BF9-33 (45 PHR)	370 (-27%)	350 (-31%)	4540 (-24%)	4300 (-28%)	710 (-3%)	720 (-1%)	410 (-11%)	410 (-11%)	85 (-7%)
#5 B-605/.95MR mPDA/ DEEA (40 PHR)	300 (-32%)	280 (-36%)	4030 (+27%)	4300 (+35%)	630 (-20%)	650 (-18%)	360 (-5%)	370 (-3%)	30 (-25%)
#6 B-605/.95MR mPDA/ S-140 (45 PHR)	270 (-25%)	230 (-35%)	4440 (+8%)	4210 (+2%)	680 (+5%)	680 (+5%)	390 (+10%)	360 (+3%)	20 (-10%)

Desert Aged = 6 months moderate desert chamber

Tropical Aged = 6 months moist tropical chamber

NC = No significant change

These compounds were submitted for physical testing and the test results appear in the graph in Figure 7. From Figure 7, desirable properties in terms of high elongation, good tear, low compressibility and low modulus were observed at a density of approximately 25 lbs./cu. ft. In working with this density, the proper ratio of NH_2 to NCO was determined to be near 0.90 from the data plotted in Figure 8. Figure 9 shows that approximately the same density can be obtained from the same amount of Nitrosan whether the foam be free blown or blown in a mold. Figure 10 shows that water absorption decreases with an increase in density.

The initial outsole compound having the best overall properties had the following formula:

	<u>Parts/100</u>
Vibrathane B-602	100
Silicone SF-1079	2
MPDA	7.14
Plasticizer S-160	9.42
Nitrosan	1
Plasticizer S-140	1

The outsole compound of the boot constructed under the past project utilized methylene chloride instead of Nitrosan as the blowing agent.

Nitrosan was chosen because it gives a greater amount of closed cell structure than does methylene chloride. Also, more plasticizer can be incorporated into the compound when Nitrosan is used; this makes for a compound with better low temperature properties and allows for a more flexible outsole which gave better traction.

At this point, a lightweight insulated boot constructed from the best materials developed to date was molded from an electroformed mold and cast aluminum last previously developed. The mold was not Teflon-coated and required the use of a mold releasing agent. The use of a mold release required that all surfaces to be sprayed with an outer skin be

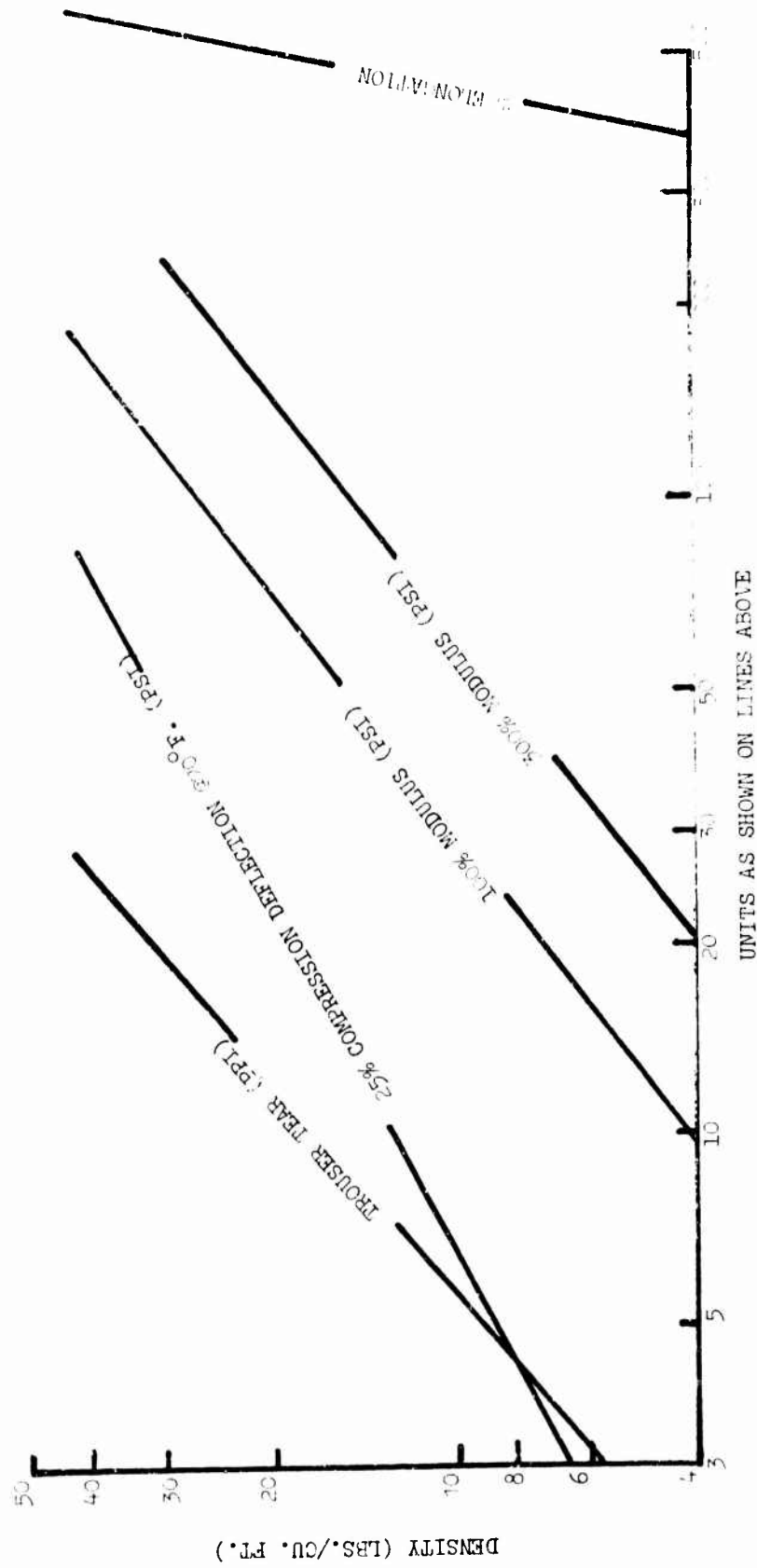

FIGURE 7

PHYSICAL PROPERTIES OF STARTING FORMULATIONS FOR POLYURETHANE FOAM OUTSOLE

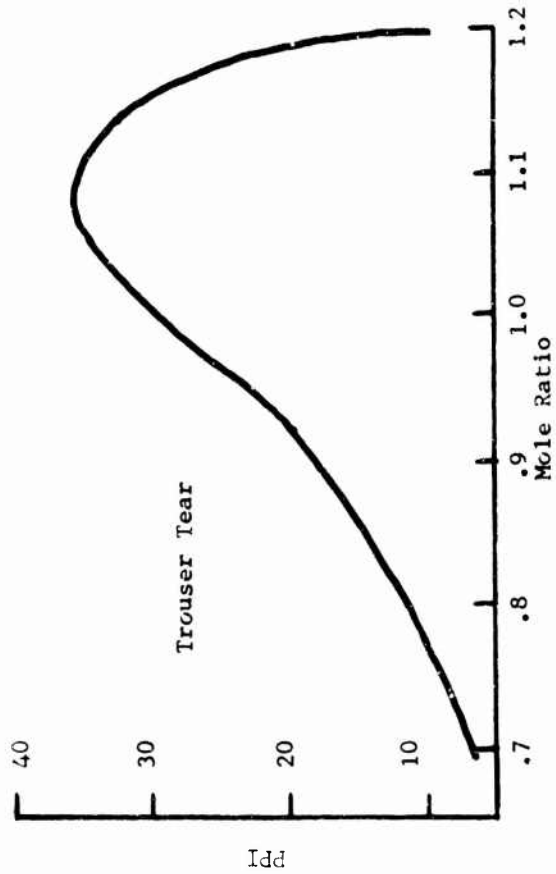
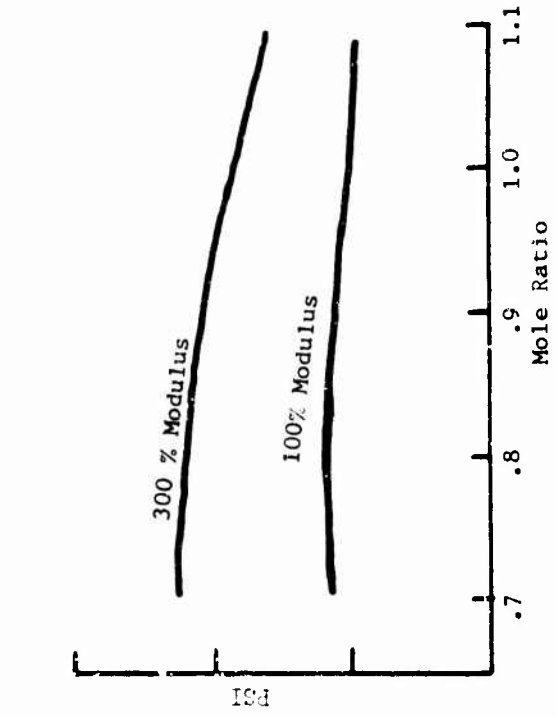
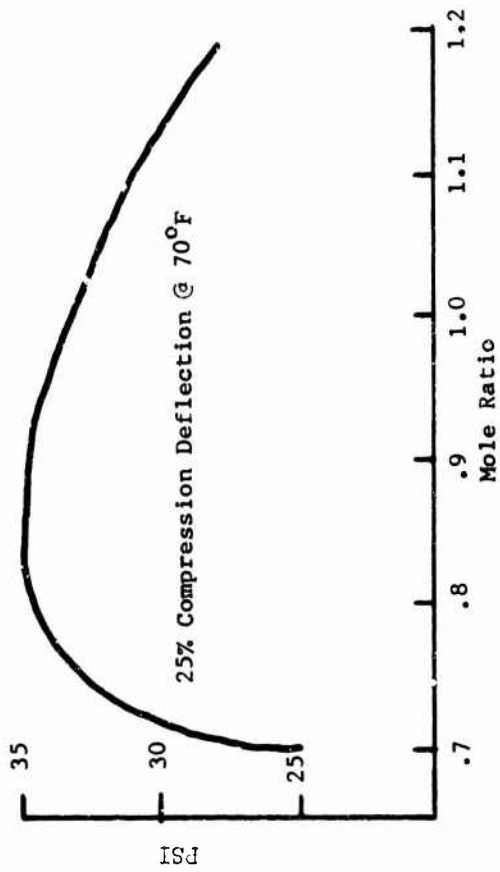
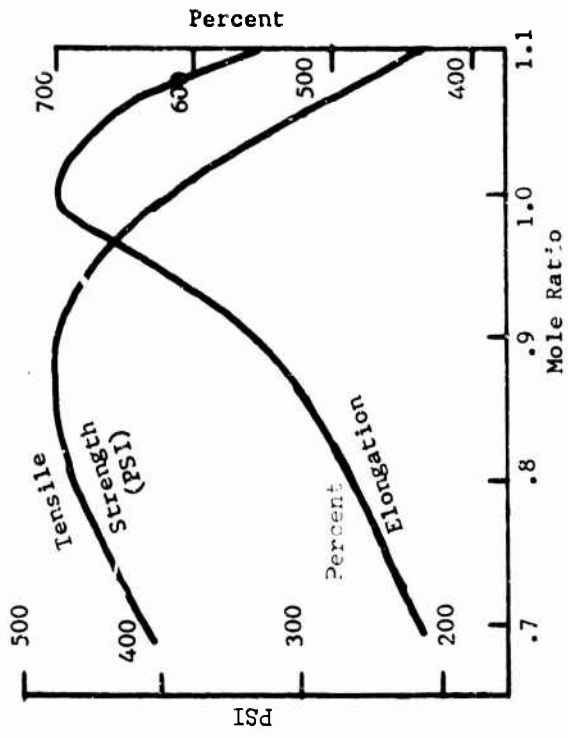
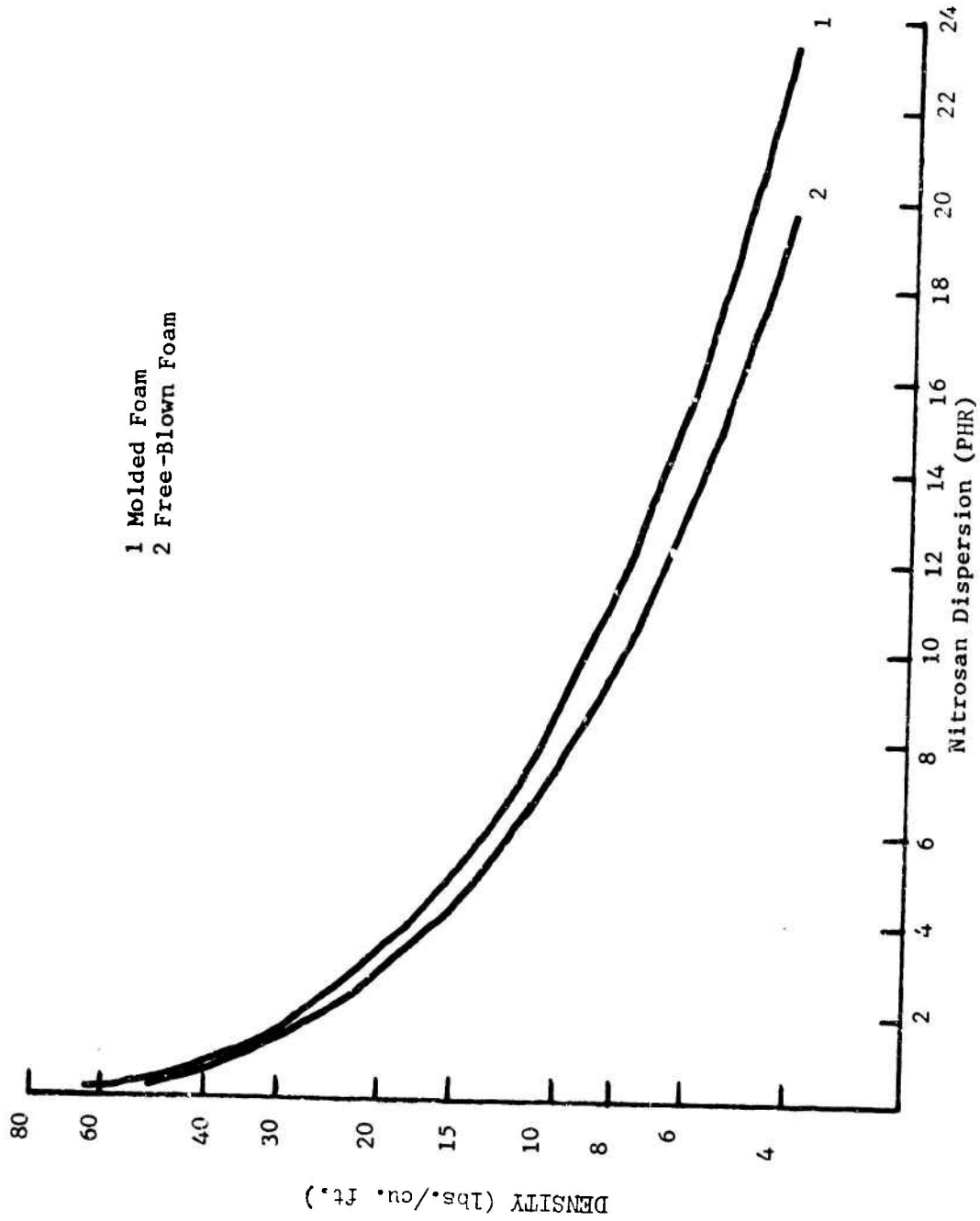

FIGURE 8
PHYSICAL PROPERTIES OF POLYURETHANE FOAM HAVING 25 LBS./CU. FT. DENSITY



1 Molded Foam
2 Free-Blown Foam

FIGURE 9

COMPARISON OF MOLDED FOAM AND FREE BLOWN FOAM DENSITIES

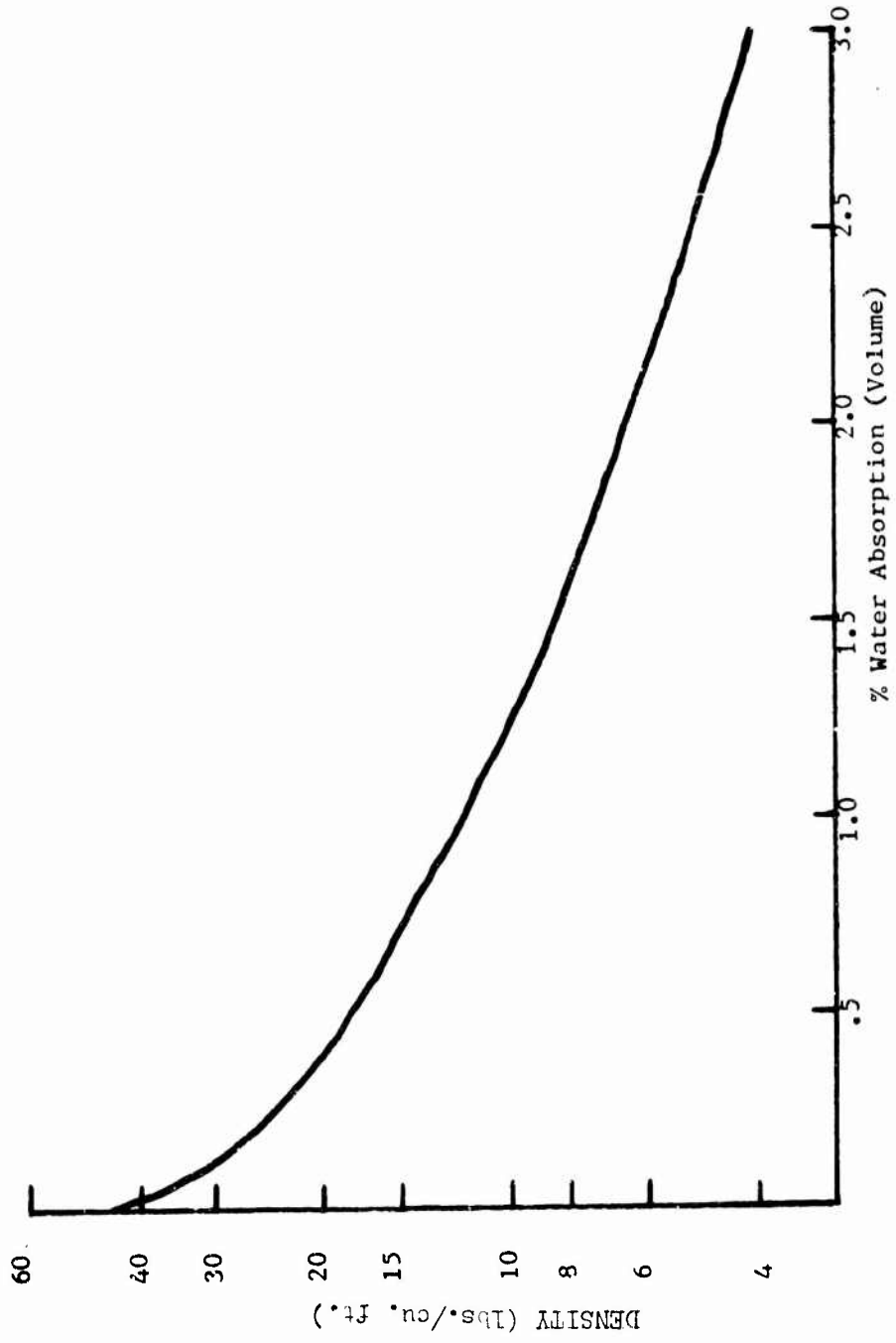

FIGURE 10
DENSITY VS. PERCENT WATER ABSORPTION

It is noted, and that the outer edge of the outsole be buffed to improve skin adhesion. Listed below are the formulations and the weights of the components which make up the boot.

<u>Component</u>	<u>Weight</u>	<u>Ingredient</u>	<u>PHR</u>
Insole	15 grams	Estane 5707	100
		DBEA (dibutoxy ethyl acetate)	25
		S-6531 Silicone	5
Outsole	260 grams	Vibrathane B-602	100
		Benzoflex 9-88	15
		mPDA (meta phenylene diamine)	4
		L-5310 Silicone	2
		Nitrosan	1
Upper Insulation	155 grams	Vibrathane B-602	100
		Benzoflex 9-88	42
		mPDA	4
		L-5310 Silicone	2
		Nitrosan	8
Outer Skin	130 grams	Vibrathane B-605	100
		mPDA	3.8
		Benzoflex 9-88	30
		Pigment	5
Total Boot Weight	550 grams		

The initial outsole formulations were later adjusted to reflect the knowledge gained by the extensive evaluation of skin samples. Faster reacting foam formulations were desired to improve processing. To accomplish this goal, a series of formulations using a blend of Vibrathane B-602 and Vibrathane B-605 were prepared and tested. Visual observations seem to indicate that improved cell structure could be obtained when using Santicizer S-140 instead of Benzoflex 9-88. A series of different density formulations using Santicizer S-140 were submitted for extensive physical testing. A blend of Vibrathane B-602 and Vibrathane B-605 was also used to study foam formulations for the outsole. The blend studies were performed so as to attempt to produce a quicker reacting foam formulation which might result in better processing. Also, Santicizer S-140 plasticizer was used solely in these formulations since it tended to produce the best cell structure. These evaluations included the formulation of four foam samples which would give a range of densities. The composition and

physical properties of these foam samples are listed in Table IX. The tensile strength varies directly with the density of the foam whereas the % elongation varies inversely with the density. Both the Ross flex (ASTM D-1052-55) data and the DeMattia flex (ASTM D-813-59) data were excellent for all of the foam samples. Both flex tests were run according to ASTM procedure except that no initial cutting of the sample was performed in either case. The tests were performed to measure flex cracking rather than cut growth.

Although the physical properties of these compounds were in many ways satisfactory, the processing presented difficulties. The Vibrathane B-605 was removed and replaced with the Vibrathane B-602. Also, adjustments were made in the level of plasticizer so that the desired density of about 25 lbs./cu.ft. could be obtained for the outsole foam compound and about 12 lbs./cu.ft. for the upper foam compound. The resulting adjusted compounds for the upper foam insulation and the outsole appear below and in Table X.

<u>INGREDIENT</u>	<u>OUTSOLE (PHR)</u>	<u>UPPER INSULATION (PHR)</u>
Vibrathane B-602	100	100
Santicizer S-140	25	25
MPDA	4	4
Santicizer S-160	4	4
SF 1079 Silicone	2	2
Nitrosan	0.7	7
3041 Black	2.1	-
US-15N	0.7	3

The prepolymer for both the outsole and upper foam insulation was Vibrathane B-602 alone. The level of Santicizer S-140 plasticizer was set at 25 pts/hundred for both compounds. The level of Nitrosan in the upper foam insulation compound is greater than the level of Nitrosan in the outsole compound so that lighter density in the upper foam insulation compound could be obtained.

The physical properties, listed in Table X show that the compound adjustments resulted in approximately the desired densities of 25 and 12 lbs./cu.ft. for the outsole and upper foam insulation, respectively. Tensile strength was increased while elongation remained about the same for the new compounds. The compression set at 158°F for the new foam formulations decreased considerably over the preliminary ones whereas the compression set at -20°F remained about the same.

An actual outsole having a composition identical to the one listed in Table X was flexed on a UniRoyal outsole flexing machine. This machine was built by UniRoyal, Inc. and when an outsole is mounted in

TABLE IX
FOAM SAMPLES

	<u>#1</u>	<u>#2</u>	<u>#3</u>	<u>#4</u>
Vibrathane B-602	60	60	60	60
Vibarthane B-605	40	40	40	40
Santicizer S-110	53.2	53.2	53.2	53.2
n-PDA	3.2	3.2	3.2	3.2
L-5410 Silicone	1.6	1.6	1.6	1.6
Nitrosan	3.2	9.7	12	12.8
US-15N Plasticizer	1.4	4.2	5.1	5.5
Density (lbs./cu.ft.)	17.9	9.7	7.0	5.9
Modulus (PSI) 100%	12	3	0.6	-
200%	23	6	3	0.8
% Elongation	390	490	500	550
Tensile Strength (PSI)	44	22	13	11
Ross Flex (ASTM D-1052-55)	(No cracking after 800,000 cycles)			
DeMattia Flex (ASTM D-813-59)	(No cracking after 1,038,000 cycles)			
25% Compression Set (after 22 Hrs. @ -20°F)	100.2	91.6	97.4	101.4
50% Compression Set (after 22 Hrs. @ 158°F)	82.1	91.4	95.5	96.9
Bashore Resilience (ASTM D-2632)	58	50	40	37
Flammability (ASTM D-1692)	(Self - Extinguishing)			
% Water Absorption (ASTM D-1056-62)	15.1	21.9	17.9	12.9
25% Compression Deflection (PSI)	(ASTM D-2406)			
@ 75°F	4.90	1.60	1.15	0.4
@ 50°F	4.60	2.00	1.00	0.3
@ 25°F	4.40	1.85	0.95	0.2
@ 0°F	4.35	1.90	1.25	0.4
@ -10°F	5.00	2.10	1.60	0.5
@ -20°F	5.30	2.20	1.65	0.7

TABLE X

FINALIZED FORMULATIONS AND PHYSICAL PROPERTIES OF OUTSOLE AND UPPER INSULATION

	<u>Outsole</u>	<u>Upper Insulation</u>
1. <u>Composition (PHR)</u>		
Vibrathane B-602	100	100
Santicizer S-140	25	25
MPDA	4	4
Santicizer S-160	4	4
SF-1079 Silicone	2	2
Nitrosan	0.7	7
3041 Black	2.1	-
US-15N	0.7	3
Weight (Oz.)	L-9.8 R-10.7	L-7.6 R-7.2
2. <u>Physical Properties</u>		
Density (lbs./cu.ft.)	28	12
100% Modulus (PSI)	33	12
300% Modulus (PSI)	138	47
Tensile Strength (PSI)	290	65
Elongation (%)	550	440
Trouser Tear (PPI)	5	2
*NBS Abrasion	22	-
<u>25% Compression Deflection</u>		
@ R.T. (PSI)	33.8	5.5
@ -20°F (PSI)	45.0	13.0
<u>50% Compression Set</u>		
a. After 22 Hrs. @ 158°F	25%	68%
b. After 22 Hrs. @ 70°F	8%	0%
<u>25% Compression Set</u>		
(After 22 Hrs. @ -20°F)		
a. Reading After 10 Sec. Recovery	100.0%	96.4%
b. Reading After 30 Min. Recovery	92.5%	94.2%

* Performed on outsole core - cannot be determined on outsole skin

the machine, the toe is bent towards the inside shank at an angle of about 60 degrees from the horizontal. The flexing cycle is about one per second.

Before flexing, a 1/4-inch cut was initiated in the outsole. The percent growth of the cut was plotted as a function of the number of flexes. This plot is illustrated in Figure 11. One hundred twenty percent cut growth occurred after 30,000 flexes - at which point the test was terminated.

In general, the data indicated that these formulations were adequate to produce the outsole and upper foam insulation for prototype boots. The physical properties of the outsole and upper foam insulation listed in Table X should serve as specification guides for these materials. An insufficient number of boots was produced to establish tolerances.

3. Sock Lining

The initial sock lining developed was a skin obtained by spraying a polyurethane formulation onto a metal foot form (last) and drying. The formulation and typical physical properties for this polyurethane sock lining are listed as follows:

<u>Formulation</u>		<u>Physical Properties</u>	
<u>Ingredient</u>	<u>PHR</u>		
Estane 5707	100	100% Modulus (PSI)	2000
3041 Black	5	300% Modulus (PSI)	3500
THF (Solvent)	1430	Tensile Strength (PSI)	5800
		Elongation (%)	450
		Split Tear (PPI)	200
		Die C Tear (PPI)	700

This sock lining was extremely durable and lightweight-ranging in weight from 0.6 oz. to 0.9 oz. One disadvantage of the lining was that it lacked ease of doffing after wearing a given period of time due to the accumulation of perspiration on the wearer's foot. A solution to the problem was to look for a material having good slip, and with a ribbed construction so that air may by-pass the foot as it was being withdrawn from the boot.

A nylon sock lining was utilized in the first attempt to achieve this objective. The nylon sock lining was stitched from Nylon 1818 which is a 100% nylon tricot fabric having a weight of 3.57 oz./sq. yd. and a gauge of .011-inches. The percent water absorbency was less than 2%. This first attempt was not too successful because the liquid polyurethane came through the nylon and nullified the good slip finish; also, the adhesion of the nylon to the polyurethane foam was poor.

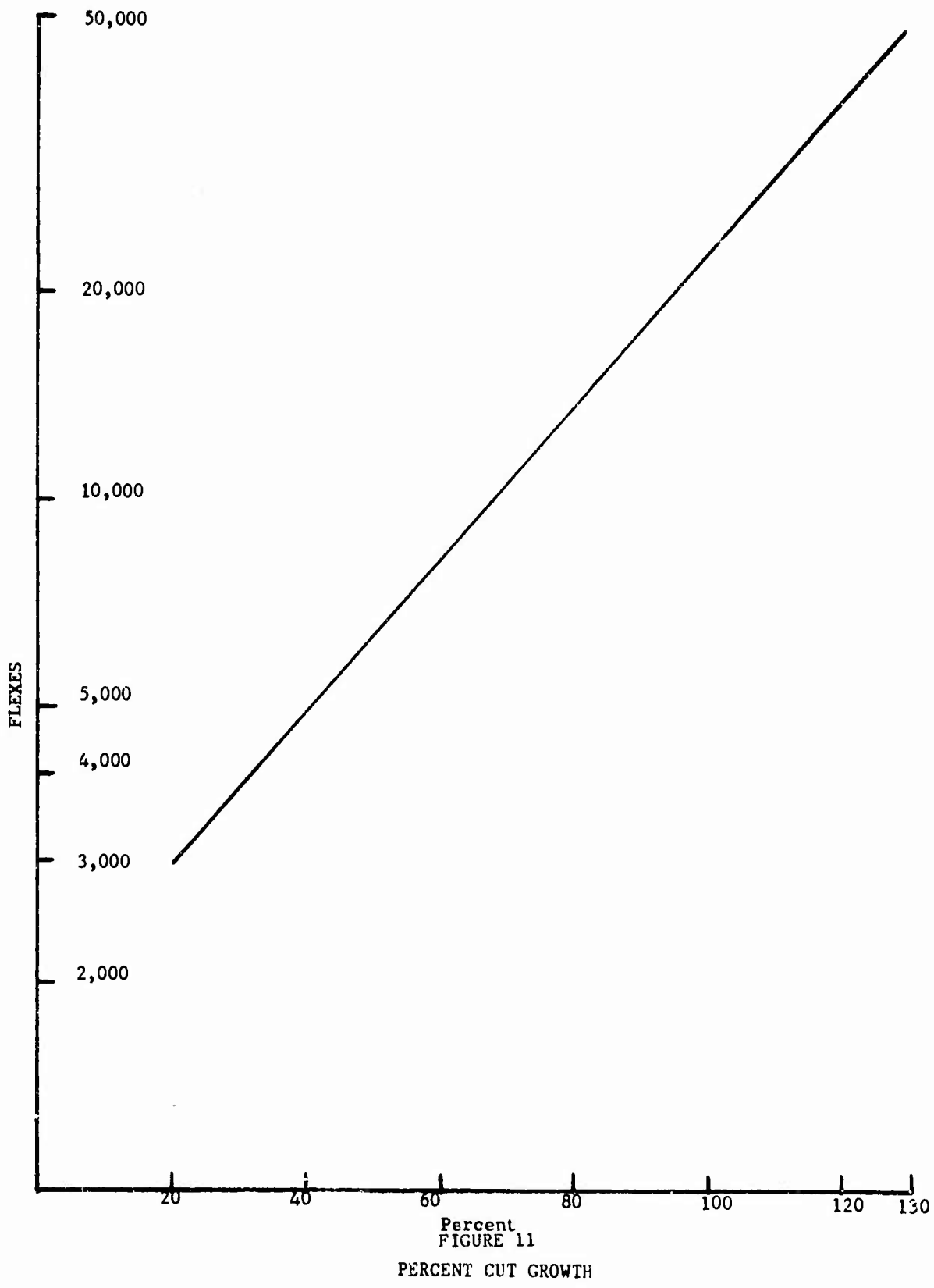

FIGURE 11

PERCENT CUT GROWTH

The next approach was to evaluate coated fabrics having a side to which polyurethane upper foam would adhere and an opposite side with good slip. Polyvinyl chloride (PVC) coated cotton was investigated first. Boots were made with sock linings and constructed both with the PVC against the foot and with the cotton against the foot. The overall weight of these sock linings was approximately 2 ounces as compared to about 1/2-ounce for the polyurethane sock lining. When the PVC side was against the foot, there still appeared to be drag and little slip; however, when the cotton side was against the foot, it appeared to offer good slip.

A second coated fabric evaluated for a sock lining was urethane coated nylon. This material was used so that the nylon was against the foot and the urethane skin against the urethane foam. However, this material proved to be unsatisfactory because of poor adhesion of the urethane skin to the nylon and because of the high water absorbency of the cloth material. The one advantage which this sock lining had was its relative lightness - one ounce.

A third sock lining was constructed of a nylon fabric laminated to a cotton fabric with a natural rubber gum layer in between. The fabric which was used against the foot was a 100% nylon tricot having a weight of 2.7 ounces/sq. yd. This material is also known as 2 Bar Jersey Tricot Net. The fabric against the urethane foam was a 3-ounce ribbed net cotton. The cotton and nylon were laminated together with a .006-inch thick gum rubber coat and vulcanized before the material was stitched into a sock. This sock lining appeared to be the best currently developed since it provided the nylon fabric against the foot for good slip and cotton fabric on the other side for good adhesion to the polyurethane foam. The gum coat between the two fabrics prevented the liquid polyurethane from coming through to the nylon sock and nullifying the good slip finish. This sock lining was used in Prototype boots R-3003 through R-3007 and in 50 pairs of Prototype R-3003.

B. Last and Mold Design

Prior to constructing a new, aluminum, snug ankle last, new fitting measurements were made so that the last would match a standard size 10 foot. This added fitting was necessary since the foot portion of the last supplied by the U. S. Army Natick Laboratories was revised from lasts provided for previous projects. The supplied last was a U. S. Mil. V combat boot last. Also, the new last required redesigning of the leg portion of the last to improve fit. The last design which was proposed had a tighter ankle which would prevent the boot from slipping at the heel and when combined with the new stretchy skin and foam, would still permit ease of donning and doffing. A wood master was fitted to a standard size 10 foot and an aluminum last was constructed from the master. The last was then built up with wax and the built up model was used to produce a rigid polyurethane mold that

could be used in constructing a model boot. The insulation of the boot produced from this mold would have a thickness equal to that of the wax used to build up the last. In building up the last with wax, insulation thickness was increased overall from insulation thicknesses used in boots produced during previous projects. The polyurethane mold was used to produce the first crude prototype (XP-1). Although this crude prototype was not truly representative of the final formulations and manufacturing process, it was made to determine if the insulation thickness would be adequate before constructing aluminum molds - thereby minimizing expense. The boot was bulky and had a plane bottom outsole which was buffed to the proper size. This crude model was submitted for a foot insulation test. The data obtained from this crude prototype served as a guide towards determining insulation thickness for the first pair of aluminum prototype molds.

In evaluating this crude prototype boot for fit, it was determined that the ankle was too tight; fit in the foot area was fine and there appeared to be enough room in the toe area and across the ball of the foot. A second last was redesigned so that there was more room in the ankle area for ease of donning and doffing. The newly designed pair of lasts was used in constructing the first pair of aluminum molds. In constructing the pair of aluminum molds, an extensive study of foot insulation data was necessary to determine the insulation thickness for the first pair of prototype boots. The crude prototype boot (XP-1) which was first constructed and submitted for Copper Foot data was compared to other boots whose insulation thickness and overall insulation value were known.

The foot insulation data and insulation thickness of three light-weight insulated boots are tabulated in Table XI. Boot IC-3 is an early prototype and boot IC-312 is a later prototype, both produced under the project which preceded the current work. A careful analysis of the thickness and Clo* Values of these boots led to the proposed thickness and expected Clo Values by means of extrapolation for the first pair of prototype boots that were constructed from these aluminum molds. Figure 12 shows the insulation thickness proposed for the first pair of prototype boots.

The U. S. Army Natick Laboratories provided UniRoyal with an outsole design that might increase traction. This new outsole design (Vibram Lug Design) was used in constructing the first pair of prototype molds described in the preceding section. The Vibram Lug Design is illustrated in Figure 13.

*The amount of insulation necessary to maintain in comfort a sitting, resting subject in a normally ventilated room (air movement 20 ft./min.) at a temperature of 70°F and a humidity of air which is less than 50 percent.

TABLE XI

FOOT INSULATION DATA

FOOT AREA	IC - 3		IC - 312		XP - 1		EXPECTED		PROPOSED	
	GAUGE	CLO	GAUGE	CLO	GAUGE	CLO	CLO	CLO	CLO	CLO
3	70	1.62	70	1.62	125	1.60	1.62	1.62	100	1.62
4	300	1.72	250	1.60	500	2.14	1.61	1.61	450	1.61
5	400	2.05	300	1.84	500	2.78	2.00	2.00	450	2.00
6	180	2.06	150	1.78	500	2.78	2.02	2.02	400	2.02
7	450	1.89	600	2.09	1000	2.92	1.52	1.52	600	1.52
8	360	2.67	300	2.27	750	3.50	2.76	2.76	500	2.76
9	360	2.24	300	2.06	750	3.54	2.13	2.13	500	2.13
10	500	1.85	700	2.07	1000	2.88	1.68	1.68	700	1.68
11	550	2.31	500	1.88	500	1.87	2.31	2.31	750	2.31
12	550	2.61	500	2.27	500	2.27	2.82	2.82	750	2.82
Overall		2.01		1.89		2.44				

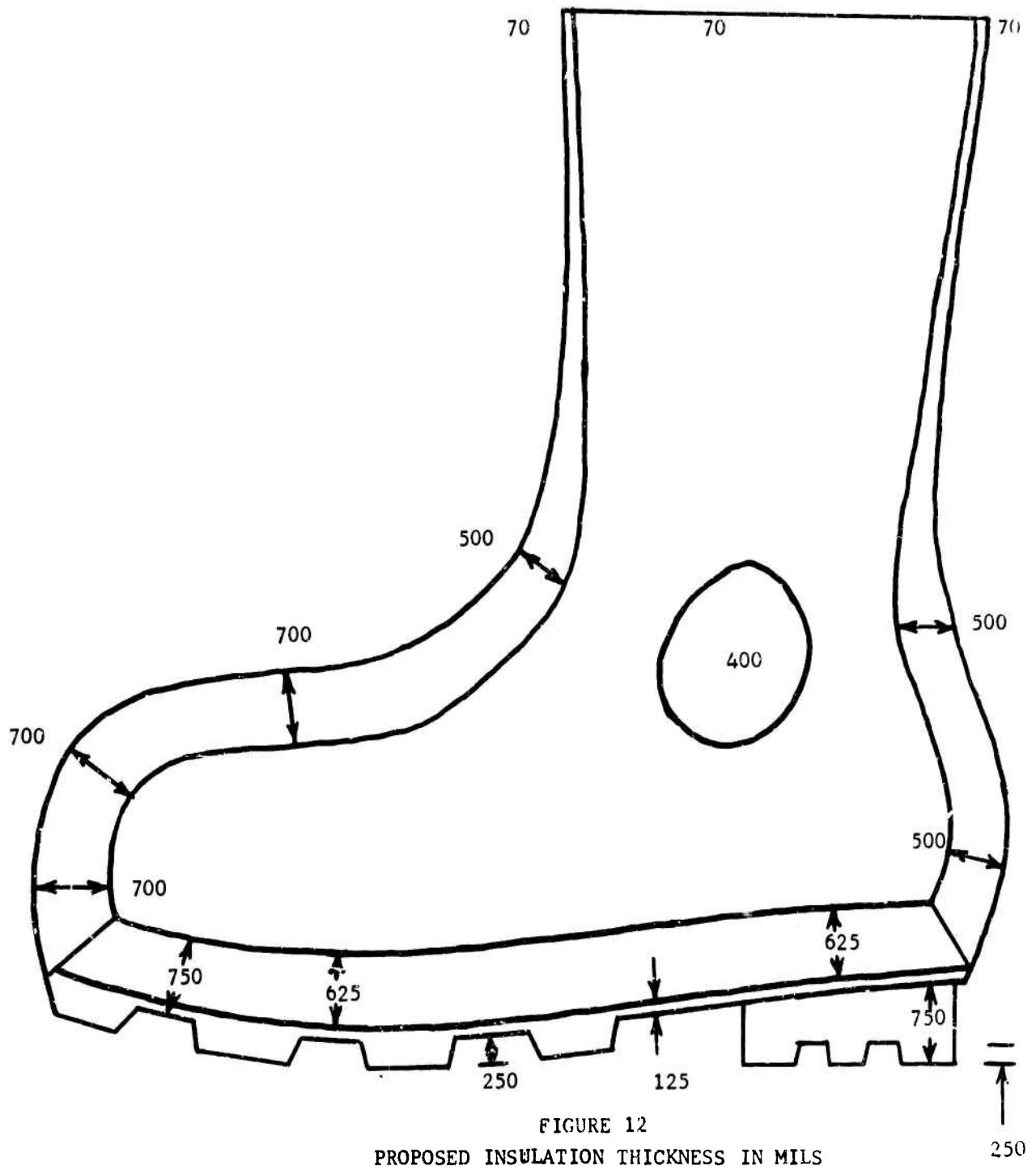

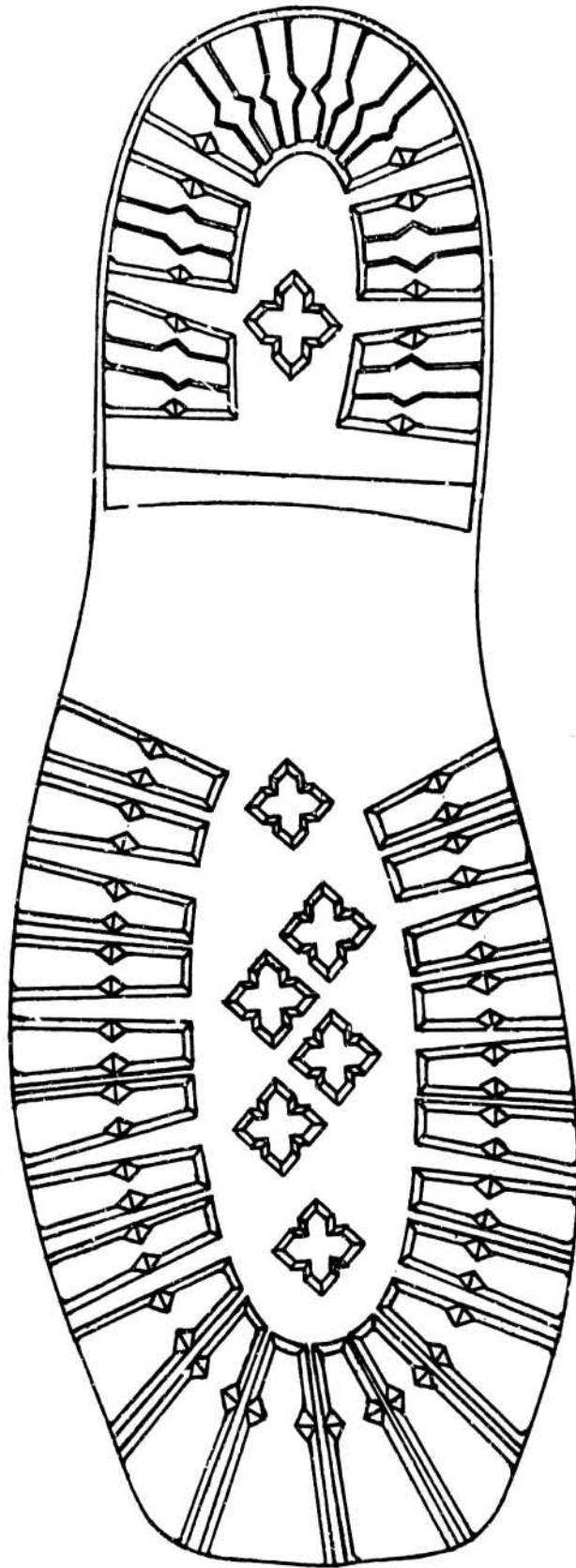

FIGURE 13
VIBRAM LUG DESIGN OUTSOLE

After receiving the pair of aluminum molds, the first pair of prototype boots was produced. The outsole pattern was designed after the Vibram Lug sole design. The upper foam insulation thickness of boots prepared from this mold conformed to the proposed thicknesses stated in Table XI.

The overall mold for each boot consists of 5 pieces and a last. One of the pieces is a sole plate containing two other pieces which are side rings and form the upper edge of the outsole when the last is rested on the rings. After the outsole is molded, the side rings are removed and the two other pieces which form the boot upper are brought together around the last which is still in the same position it was in when the outsole was formed.

The above described mold was used in preparing the first pair of prototype boots and also to prepare six identical pair of boots.

Based on wear test results which will be described later in this report, of the six additional pair of boots prepared, adjustments were made to the existing mold to produce a new mold for making future prototype boots. At the request of the U. S. Army Natick Laboratories, the changes which were made in the new mold were: (1) the toe end of the outsole was made square rather than round; (2) the heel was made larger and pushed back so that the outside edge was almost in line with the boot upper; (3) the entire outer edge of the outsole was extended so that it was in line with a perpendicular dropped from the boot upper; and (4) the new rings were fabricated so that a heel counter could be integrally molded to the outsole. In making all of the above changes, a modified Vibram Lug sole design was maintained. The above mold was used to make prototype pairs R-3002, R-3003, R-3004, and R-3007. These prototype pairs will be fully described later in this report. Also 50 additional pair of prototype R-3003 were produced for the U. S. Army Natick Laboratories.

A second major mold change made after the fabrication of the 50 pair of boots and recommended by the U. S. Army Natick Laboratories was to design an outsole having a larger wear surface in contact with the ground in the area of the ball of the foot. Several outsole designs which are illustrated in Figures 14 through 18 and identified as Outsole Design A through E, were submitted to the U. S. Army Natick Laboratories. The selected design from which to have a mold made was Outsole Design E. A new outsole mold was made and a prototype pair (R-3005) was fabricated using the formerly mentioned mold with Outsole Design E.

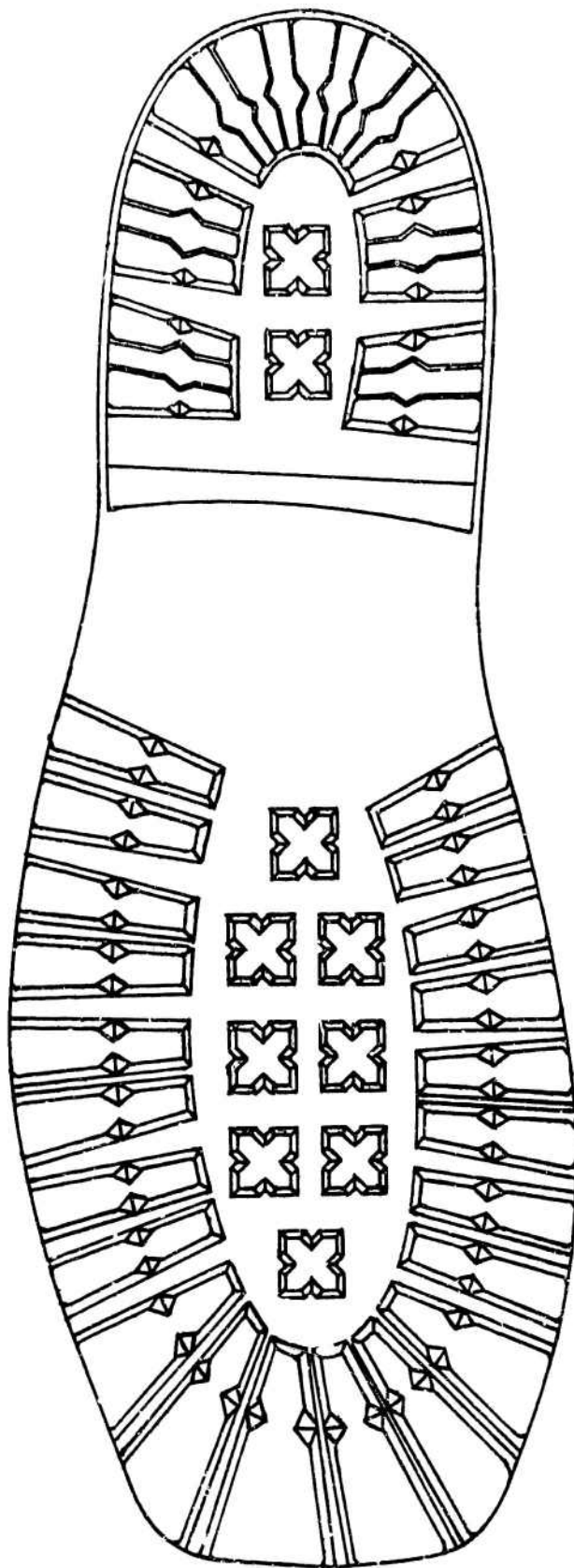

FIGURE 14
OUTSOLE DESIGN A

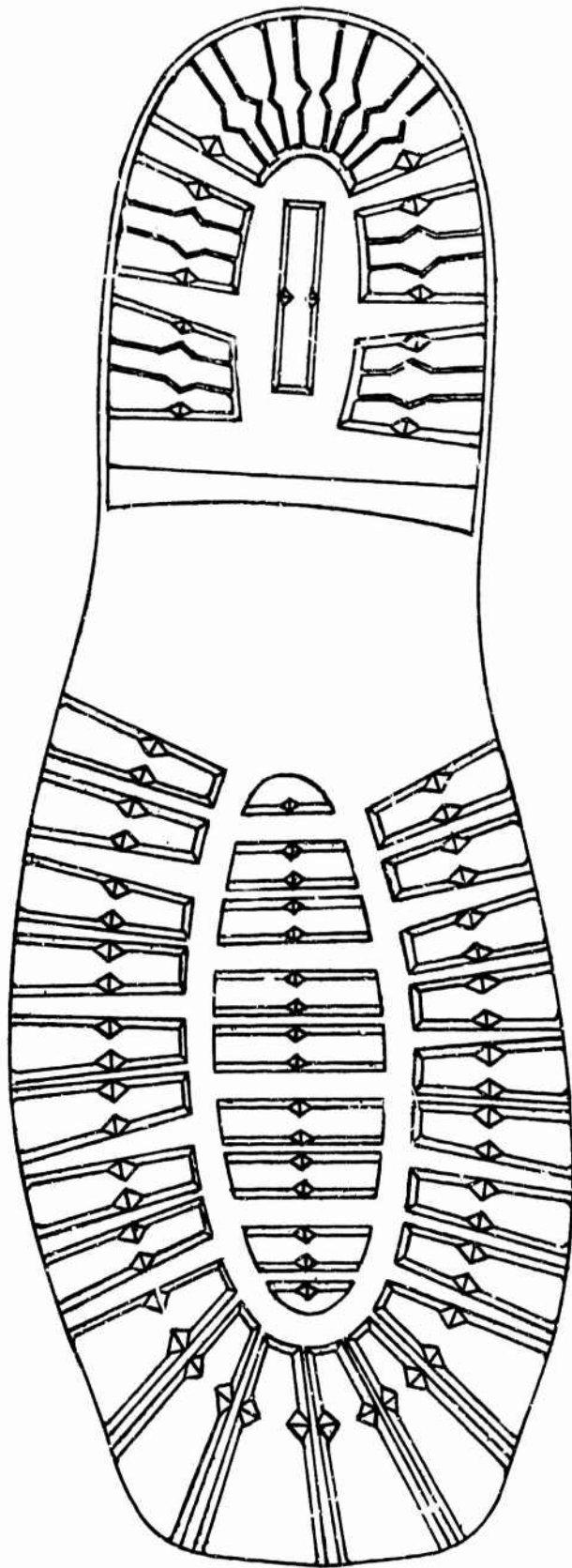

FIGURE 15
OUTSOLE DESIGN B

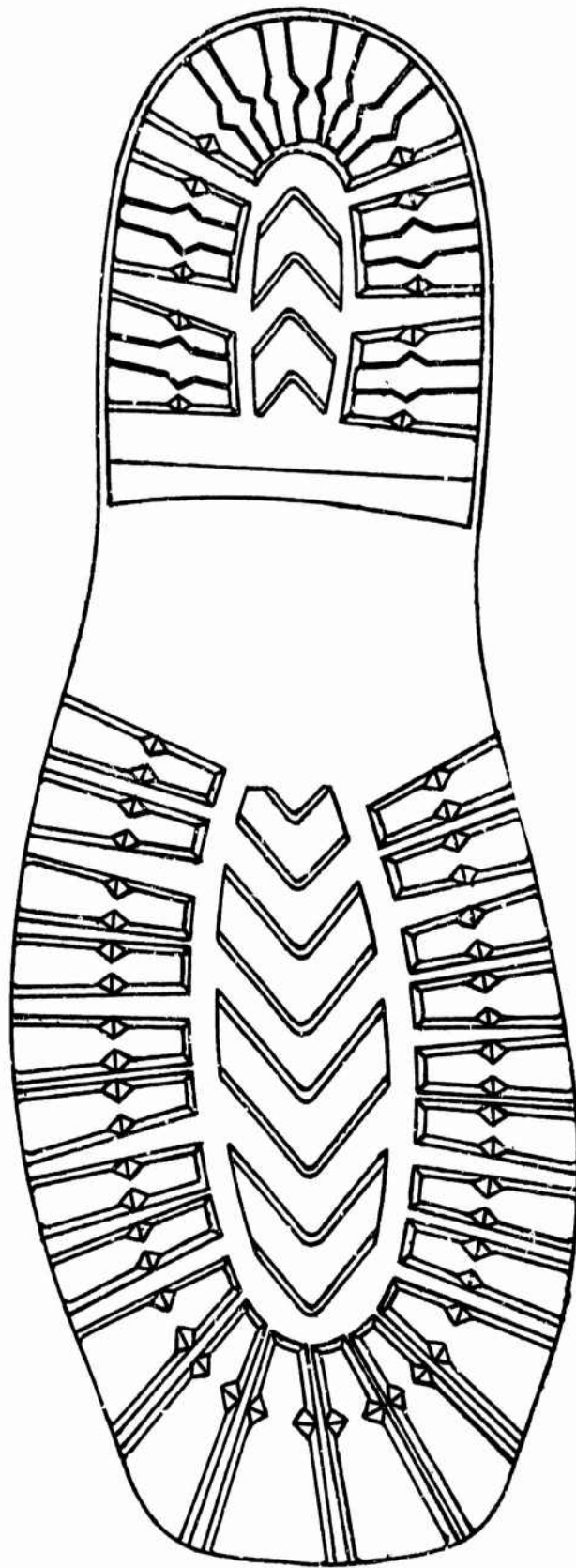

FIGURE 16
OUTSOLE DESIGN C

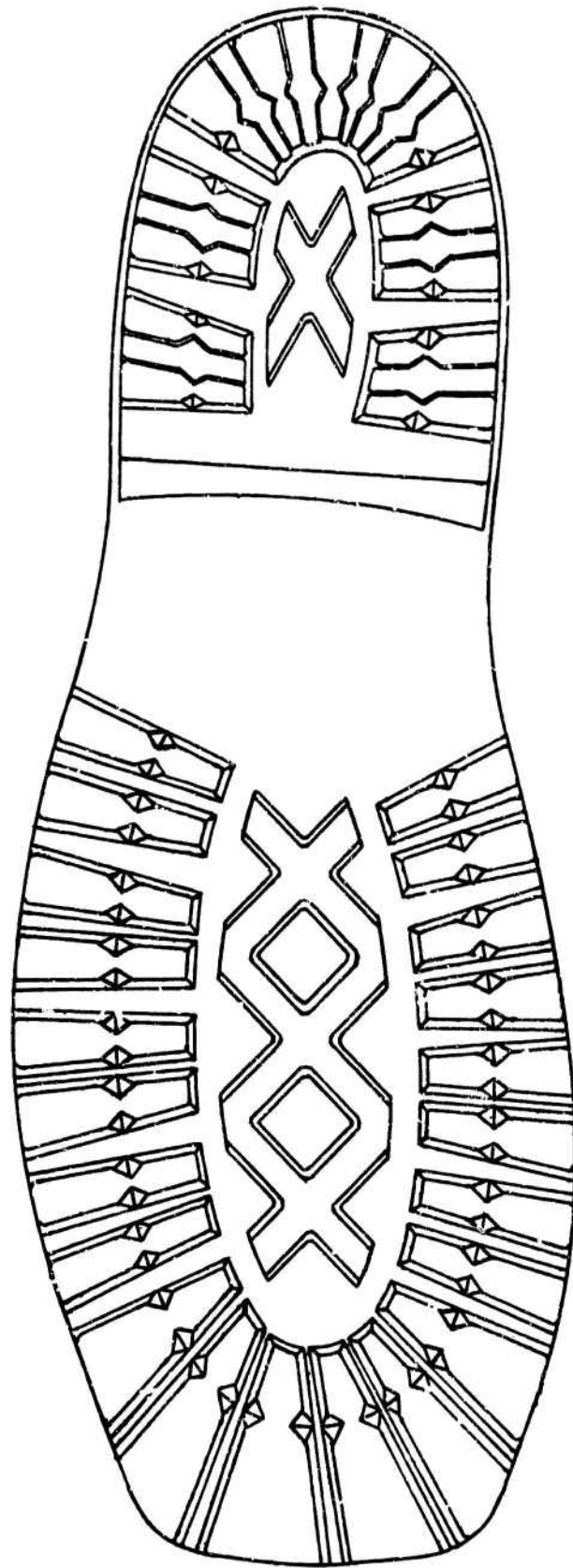

FIGURE 17
OUTSOLE DESIGN D

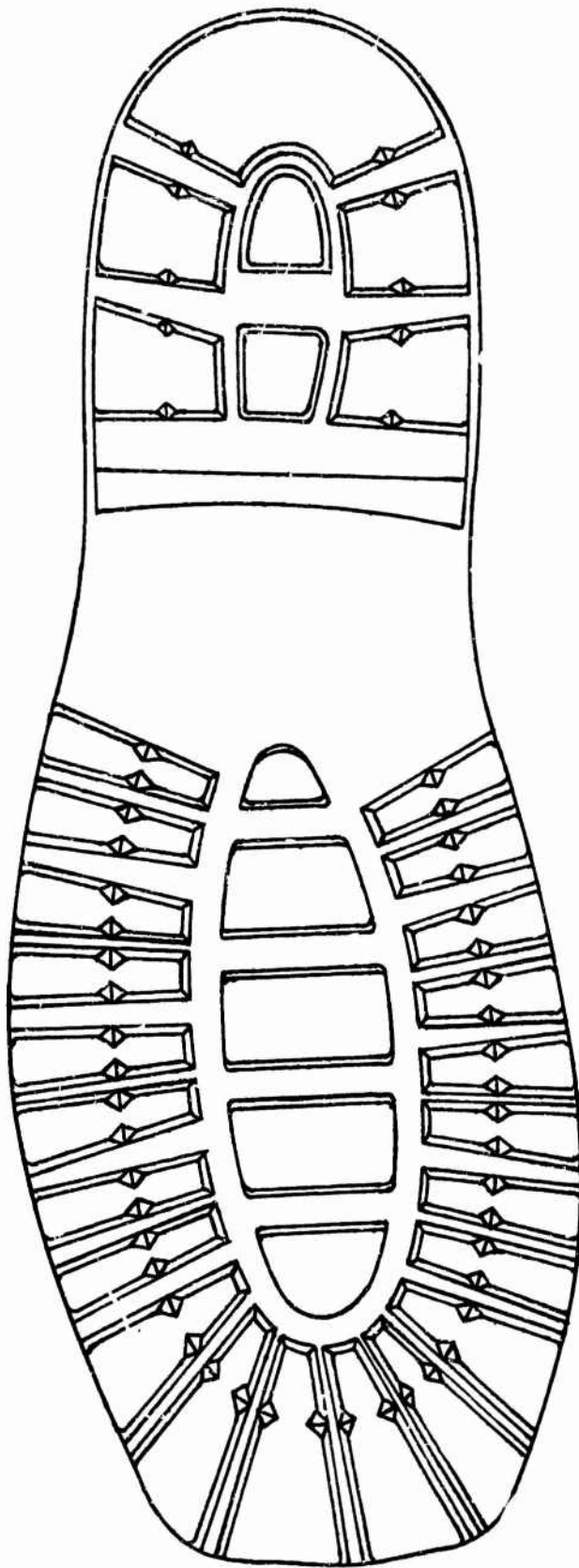

FIGURE 18
OUTSOLE DESIGN E

C. Testing

The testing data contained in the preceding Tables and Figures have already been referred to in reporting the results of material studies performed for various parts of the boot.

A lightweight insulated boot (IC-312) constructed under a previous project was submitted to a foot insulation test. This boot was then wear-tested for 100 miles. It was again submitted for a foot insulation test after wear testing. This series of tests was run on the boot in order to determine the effect of wear on the overall insulation value of the boot. The foot insulation test data which were obtained on this boot are listed below. Refer to Figure 19 to identify the section numbers with the parts of the foot. The insulation values are given in Clo. There was no significant decrease in Clo value after wear testing boot IC-312 one hundred miles.

Section	<u>CLO VALUES</u>	
	<u>Polyurethane Boot IC-312</u>	<u>IC-312 After Walked 100 miles</u>
3	1.62	1.53
4	1.60	1.69
5	1.83	1.90
6	1.78	1.81
7	2.07	1.81
8	2.29	2.45
9	2.06	2.29
10	2.06	1.96
11	1.37	1.97
12	2.25	2.21
Overall	1.39	1.89

A pair of size 10 standard insulated (cold-wet) boots were furnished by the U.S. Army Natick Laboratories to be wear tested for 100 miles. A comparison of outsole wear was made between the standard boots and the polyurethane boot (IC-312) that was previously wear tested. The wear testing of the standard Government boots helped determine if a lesser abrasion resistant, lower modulus, polyurethane compound could be utilized as an outsole compound so that traction could be improved.

The standard pair of size 10 insulated (cold-wet) boots provided by the Government were wear tested at Naugatuck, Connecticut for 100 miles and returned to the U. S. Army Natick Laboratories for a second foot insulation test. The data obtained has been tabulated below. Also, similar data for boot IC-312 are included again for comparison sake. The decreases in Clo values of boot IC-312 after walking 100 miles is not considered to be too significant. However, the mold designed for the first pair of prototype boots allowed for increased insulation in the affected areas.

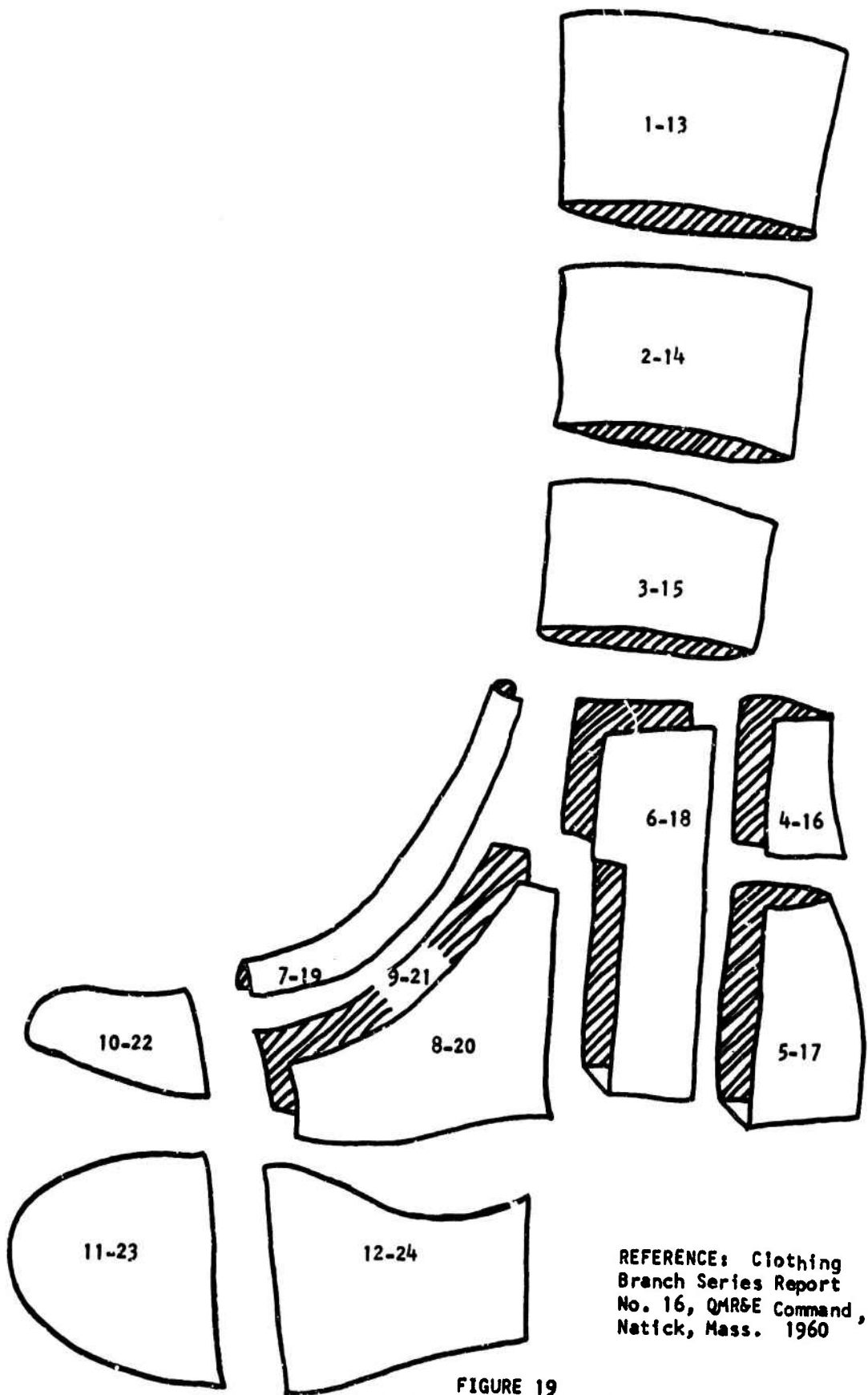

REFERENCE: Clothing
Branch Series Report
No. 16, QMR&E Command,
Natick, Mass. 1960

FIGURE 19
FOOT INSULATION TEST ZONES
54

CLO VALUES

<u>Section</u>	<u>Standard 48 oz. Boot</u>		<u>Boot IC-312 (18.2 Oz.)</u>	
	<u>Initial</u>	<u>After 100 MI.</u>	<u>Initial</u>	<u>After 100 MI.</u>
3	1.62	1.19	1.62	1.53
4	1.31	1.85	1.60	1.69
5	2.00	2.07	1.84	1.90
6	2.02	2.19	1.78	1.81
7	1.52	1.57	2.09	1.81
8	2.76	2.57	2.27	2.45
9	2.13	2.42	2.06	2.29
10	1.68	1.89	2.07	1.96
11	2.31	2.64	1.88	1.97
12	2.82	3.17	2.27	2.21
Overall	1.93	1.88	1.89	1.89

After the pair of standard Government insulated (cold-wet) boots were tested 100 miles, they were compared for wear to boot IC-312 and an experimental boot containing the new outsole compound, each of which was wear tested 100 miles. The experimental boot was made from an electro-formed mold used to produce boot IC-312 during the previous project and the outsole compound is shown on Page 39. After examining these boots, it was concluded that some of the abrasion resistant properties of boot IC-312 could be sacrificed for that of increased traction. Although the wear characteristics of the outsole of the experimental boot was not as good as that of boot IC-312, it showed less wear than that on the Government insulated (cold-wet) boots. The new outsole compound appeared to have satisfactory abrasion resistance and was much more flexible and softer at low temperatures.

Boot IC-312 and the experimental boot, containing the new outsole compound were wear-tested for a second 100 miles. The standard pair of insulated (cold-wet) boots was also wear-tested for a second 100 miles. At the completion of the wear test, all boots were evaluated and compared.

The conclusions based on this wear test were that the outsole on boot IC-312 was superior to that on the experimental boot and on the standard government cold weather boot. However, the outsole of the experimental boot containing the new outsole formulation wore less than the outsole on the standard Government cold weather boot. Consequently, the experimental outsole was considered satisfactory for use on future prototype lightweight insulated footwear. These data are illustrated on the following page.

<u>Wear Test Results After 200 Miles</u>		<u>Lightweight Polyurethane Insulated Boots (% Wear)</u>	
<u>Standard Government Insulated (Cold-War) Boots (% Wear)</u>			

<u>Area</u>	<u>Left</u>	<u>Right</u>	<u>Experimental Left</u>	<u>TC-512 Right</u>
Ball	15	15	25	10
Heel	30	30	20	7
Outer Edge of Heel	60	60	25	10

One of the six additional pair produced of Prototype R-3001 was tested for foot insulation at the U.S. Army Natick Laboratories and returned to be wear tested 100 miles. This pair of boots is coded R-3001-A, -B₁ and described in Tables XII, XIIA & XIIB. General observations which were made were that the outer skin had split near the arch of the right boot. Although the overall outsole and heel wear were considered good, pieces of a few of the cleats tore out of the right foot outsole. This may have been due to a lack in the processing techniques at that time. The boots were returned to the U. S. Army Natick Laboratories so that a second foot insulation test could be performed. This second foot insulation test was performed to determine the effect of wear testing 100 miles on the overall insulation of the boot. The foot insulation data showed that there was no loss in overall insulation after wear testing the boots for 100 miles. This same pair of boots was returned to Naugatuck to be wear tested for a second 100 miles. These boots were evaluated for wear after being wear tested 200 miles. On the left boot, there was a one inch-tear at the instep; the outsole (Vibram Lug Design) was worn mostly at the outside edge of the heel and at the ball of the foot. Several cleats located near the shank and at the toe showed chunking where parts of these cleats were torn away from the outsole. The skin of the right boot showed two tears - a 1/2-inch tear over the small toe and a 1-inch tear at the arch area. The outsole (Vibram Lug Design) was worn mostly at the outside edge of the heel, at the ball of the foot and at the toe. Several cleats located near the shank edge of the heel, ball of the foot and toe showed chunking and were torn away from the outsole. Both boots also showed that the skin was beginning to slightly peel away from the outside edge of the heel only. In conclusion, the overall integrity of these boots was maintained and they were still wearable after wear testing 200 miles at Naugatuck.

The above boots were again sent to the U. S. Army Natick Laboratories so that a third foot insulation test could be made on them. This final foot insulation test indicated that there was little change in the overall insulation value of the boots after wear testing 200 miles.

D. Production Processes

All of the boots described in this report were fabricated with a Diehl Master, three component, polyurethane mixing/metering machine. This is a laboratory machine and can be used only for limited production.

The three components which are mixed and metered by the machine are (1) prepolymer; (2) curative and (3) additives which include blowing agent and colorant. See Figure 20.

The molds into which the compound is dispensed consist of five pieces and a last. The molds are fully described in the section entitled Last and Mold Design.

The unit for spraying the skin onto the boot is a two component Binks airless spray gun. The two components are prepolymer and curative. See Figure 21.

The following is a detailed step-wise procedure describing the process used in fabricating prototype pairs of boots in the laboratory.

Lightweight Polyurethane Boot Making Process

I. Preparation of Machine

1. Turn on mixing machine. Prepolymer tank temperature is set at 220^oF. Curing agent temperature is set at 220^oF.
2. Set outsole mold preheat oven at 150^oF. Turn on oven.
3. Prepare compound mixtures.
 - a. Pour compounds into respective pots.
 - b. Allow compounds to warm up to desired temperature.
 - c. Check machine for methylene chloride (used for flushing)
4. When compound materials have warmed up for approximately one hour, machine should then be checked for proper output mole ratios.
 - a. Outsole prepolymer output is set at 60.
 - b. Outsole curing agent is set at 6½ turns.
 - c. Blowing agent is set at 12 turns.
 - d. When calibrating upper compound, curing agent is adjusted to 5 ¾ turns.
5. Before making outsole pretest shot, check buttons on side panel. See that all are on. Set auto/manual switch to auto. Set impeller speed to 82. Set timer for 3 seconds for outsole, and 7 seconds for upper.
6. Make pretest shot in cup and check. Check for expansion and cure rate. Shot should be tack free in about 90 seconds.
 - a. Flush machine.

II. Preparation of Molds

1. A nylon sock is die cut and stitched. To prevent compound seepage through seam of sock, a solution of 80% THF and 20% Estane 5707 is applied to seam.

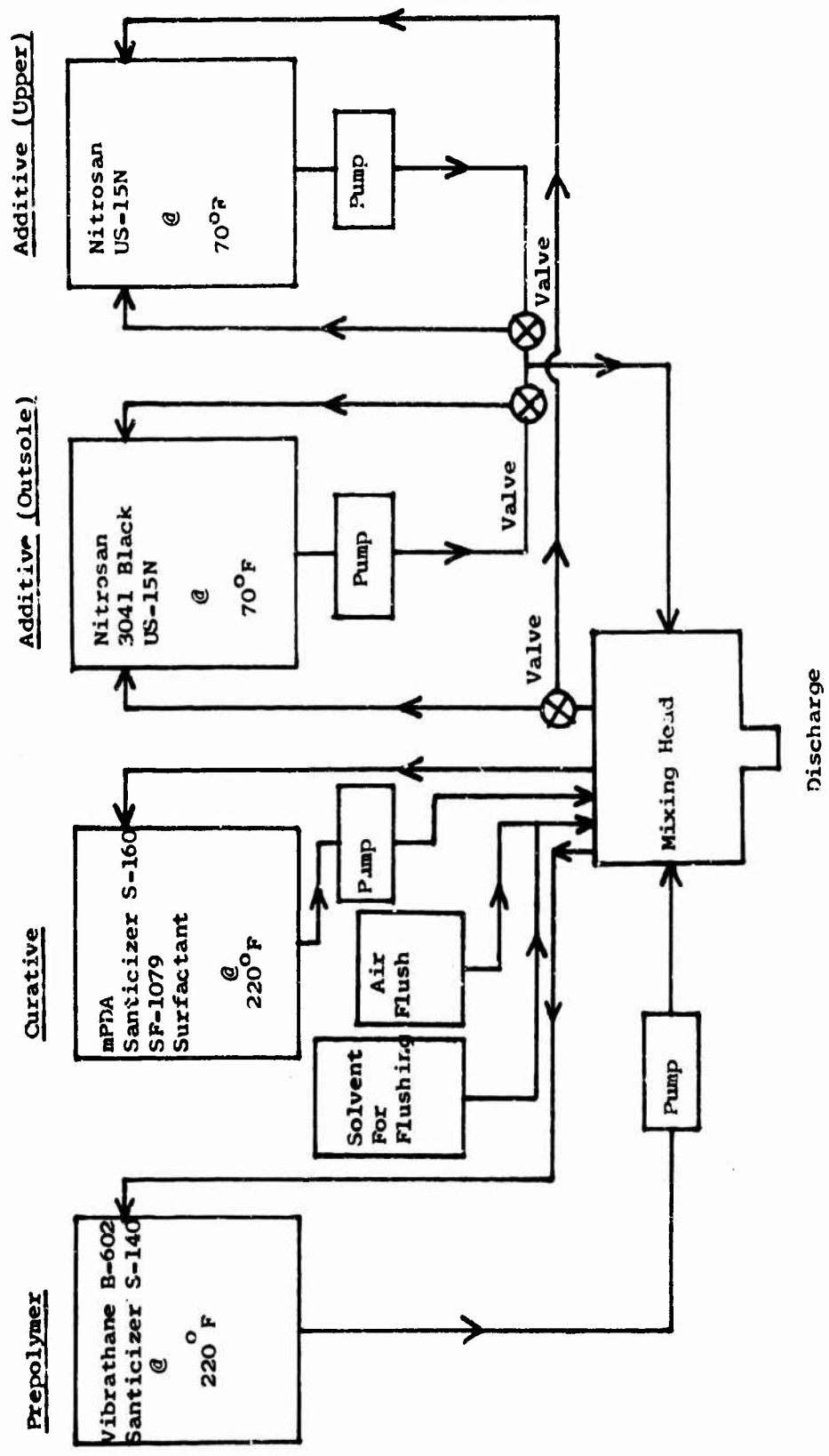

FIGURE 20
SCHEMATIC OF LABORATORY 9000 MARKING MACHINE

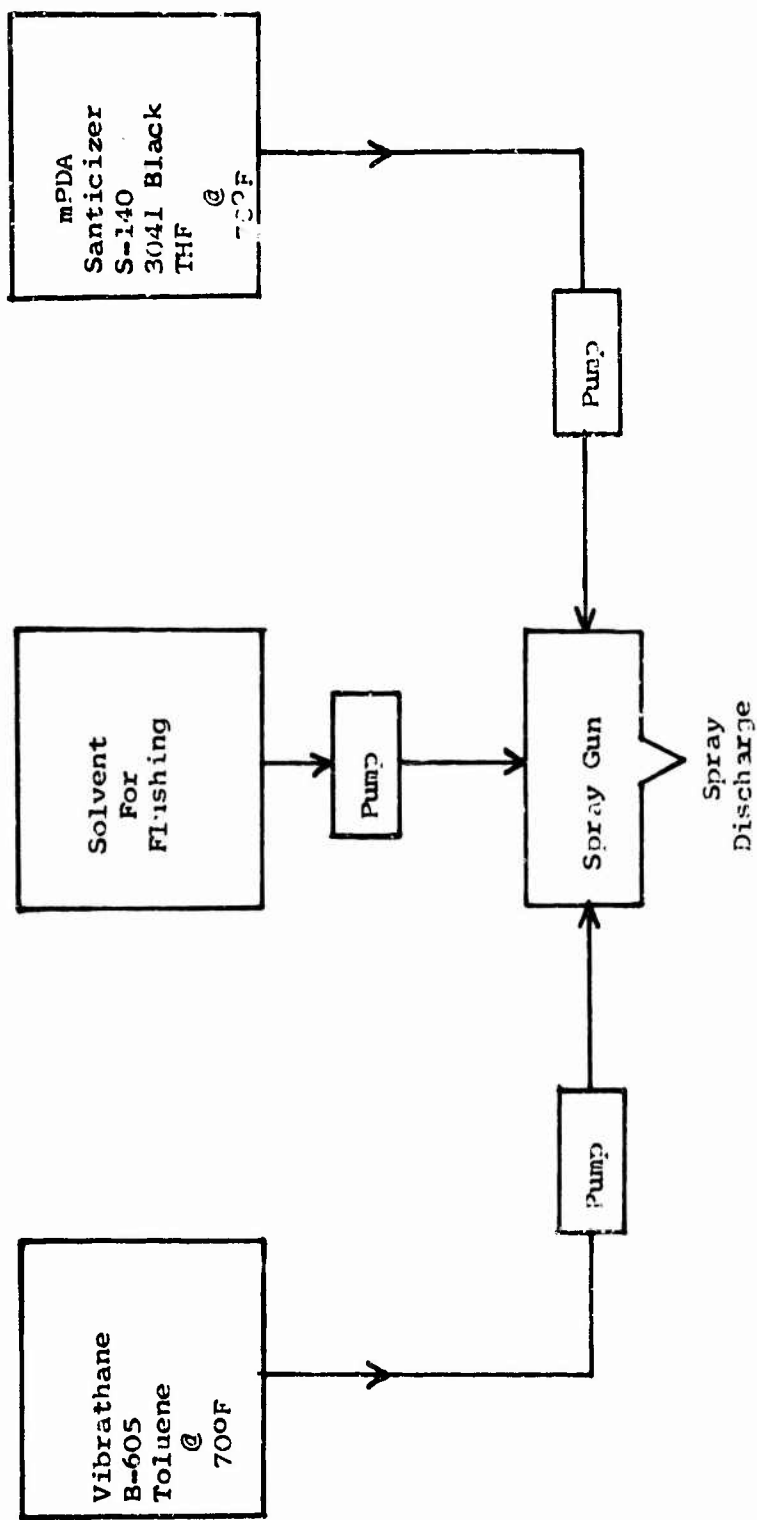

FIGURE 21
SCHEMATIC OF LABORATORY BOAT SPRAYING MACHINE

- a. Place sock lining on last and secure top of sock to last with friction tape.
 - b. Place last on mold carrier. Return to oven to reheat.
2. Check temperature of outsole mold.
 - a. When outsole mold temperature is 120^oF., assemble sock lined last, outsole mold and outsole rings.
 - b. Take outsole assembly and roll to machine.
 - c. Check side panel buttons - impeller speed is set at 82, head switch is on, auto/manual switch set on auto, timer set to 9.5 sec.

III. Outsole Compound Shot

1. After all dials are checked, prepare to make outsole shot.
 - a. With preshot cup at machine to catch first flow, collect compound for ½ to 1 sec. Shoot outsole material into outsole mold for 9.5 sec.
 - b. Place outsole mold back on carrier and secure. Flush machine.
 - c. Return outsole mold assembly to oven and cure for 15 minutes.
 - d. Repeat procedure with other foot.

IV. Upper Compound Shot

1. While outsole is setting in oven, proceed to switch outsole blowing agent stream with upper blowing agent stream.
 - a. Take cup and make 2 second pretest shot of upper blowing agent.
2. When outsole compound is set, remove outsole mold assembly from oven.
 - a. Remove outsole rings.
 - b. Assemble upper mold on carrier. Place mold halves gently on top of outsole, making sure outsole flash is well covered and upper mold is secure.
 - c. Roll mold to machine.
 - d. Impeller speed is set at 82; timer is set at 7.5 sec. Head switch is on.
 - e. With preshot cup, collect compound for ½ sec. Shoot upper material into mold for 7.5 sec.
 - f. Start mold on toe for 3-5 seconds. Heel is resting on arm of cart. Flush machine.
 - g. When flash begins to appear about half way up mold, roll mold to oven to cure for about 30 minutes.
 - h. Repeat procedure with other boot.
3. When boot has cured for 30 minutes, remove from oven and demold.
 - a. Clean mold.
 - b. Trim flash from demolded boot.

Lightweight Polyurethane Boot Spray Finishing

- I.
 1. Trim excess flash from boot.
 2. Buff trim lines around outsole and upper; also buff port holes.
 3. Cut buffed boot to height of 11 inches.
 4. Dip tops of boots in spray mixture to seal top.
 5. Apply spray mixture by hand to buffed area, where necessary.
 6. Prepared boots are then put on lasts to be sprayed.
 7. C-Vices are clamped to last for easy spray handling.

- II.
 1. Two component spray solution is prepared.
 2. Spray machine is set up with two component lines; the curing agent is one line and the prepolymer is the other line.
 3. Boots are sprayed one coat at a time to a four-coat spray.
 4. After each coat is sprayed, boot is rotated until spray sets to prevent boot from dripping and rippling.
 5. When spray coats have set, they are then placed in oven for one hour at 150° F to cure spray solution.
 6. After curing, boots are stripped from lasts and tops of boots are trimmed of overspray.
 7. If outsoles have developed spray "tips" on the, "tips" are buffed from outsoles.
 8. Buffed outsoles are now refinished with light coat of painted spray solution.
 9. Boots are now ready to be branded with serial number and weight of boots in grams.
 10. Final step consists of inspecting boots and packing them.

The above procedure is designed for the Laboratory, and since no commercial quantities of boots were manufactured, a commercial process for the fabrication of lightweight, insulated footwear was not developed. However, based upon existing knowledge of the process, a proposed future process was developed. A schematic of this process is illustrated in Figure 22.

Using the schematic in Figure 22, an envisioned manufacturing process can take place as follows:

1. A fabric lining is stitched elsewhere and delivered to the making line.
2. Hood sock over last.
3. Outsole mold is assembled automatically.
4. Polyurethane is injected into outsole mold cavity.
5. Outsole is allowed to expand and cure for five minutes.
6. Rings forming top edge of outsole open automatically.
7. Upper mold is assembled around the last and outsole automatically.
8. Upper insulation compound is injected into mold cavity.
9. Upper is allowed to expand and cure for 20 minutes.
10. Mold is disassembled automatically and boot is stripped from last.
11. Trim boot to correct height and trim flash.
12. Put boot on spraying last and place last on spraying conveyor.
13. Spraying operation will be carried out automatically by electrostatic airless equipment on the adjacent conveyor line.

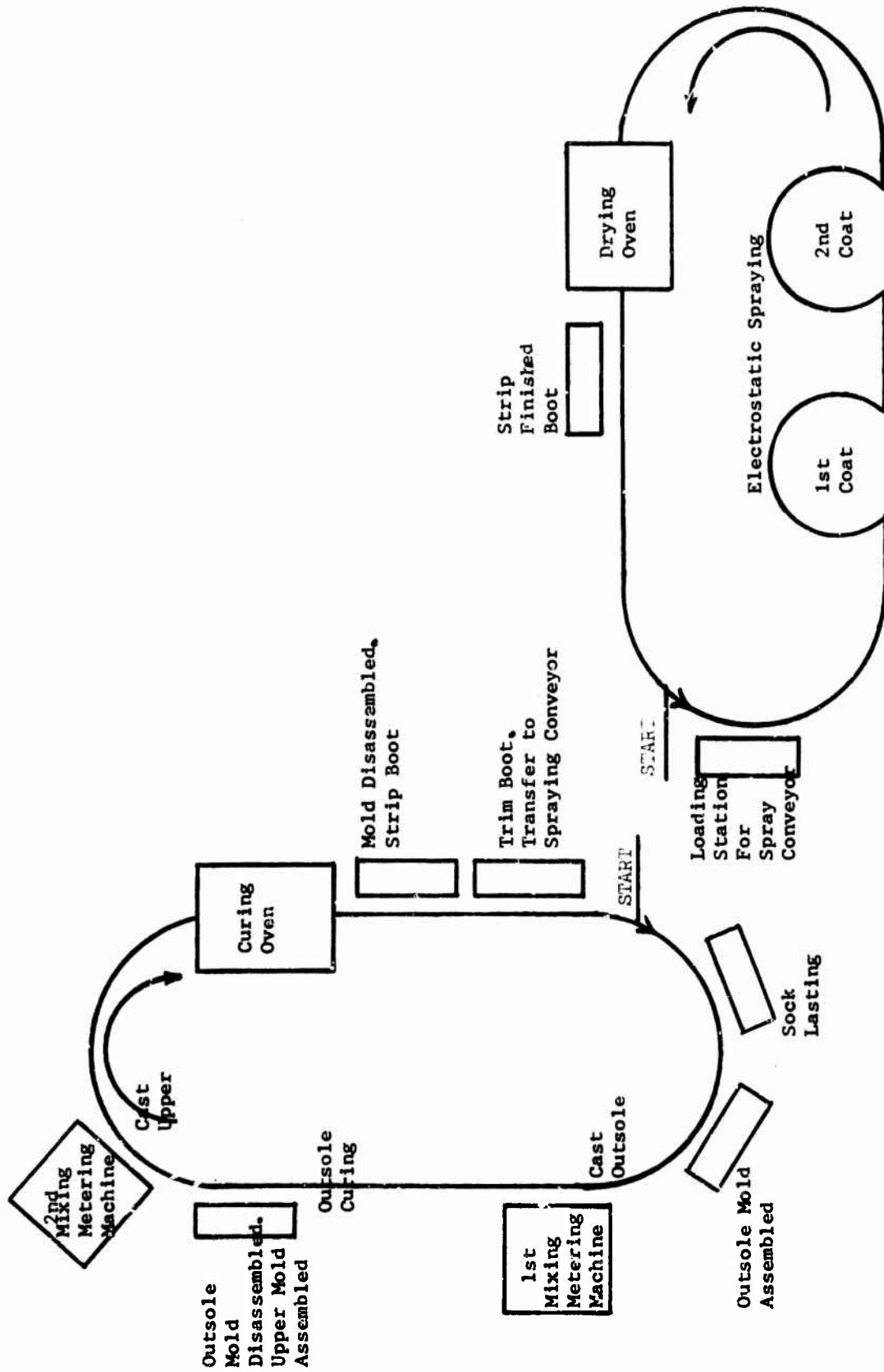

FIGURE 22
 SCHEMATIC OF PROPOSED PROCESS FOR MANUFACTURING LIGHTWEIGHT, INSULATED POLYURETHANE FOOTWEAR

The above proposed process for commercially producing lightweight insulated footwear could be developed by a manufacturer of polyurethane injection molding equipment and shown to be feasible. The current status of the art requires a development program since there is no commercial machine available to make a polyurethane, lightweight insulated boot as described above.

E. Description of Prototype Pairs

1. Prototype Pair R-3001-13,-14

Prototype pair R-3001-13,-14 was patterned after print number E-3089. The formulations for each integral part of the boot and physical properties of these parts are tabulated in Tables XII, XIII and XIIB. The sock linings were made by spraying the lasts with an Estane 5707 solution. The outsole has a Vibram Lug design and both the outsole and upper insulation are integrally cast and made from expanded polyurethane. The outer skin was a sprayed on Vibrathane B-605 which has been cured with mPDA. Also, formulations and physical properties of the six additional pairs produced of this prototype are listed in the same tables. The actual physical properties were measured only for the prototype pair and are considered to be typical for the other pairs.

2. Prototype Pair R-3002-1,-2

Prototype pair R-3002-1,-2 was patterned after print D-3089. This prototype pair differed from prototype pair R-3001-13,-14 in that (1) the toe end of the outsole was square rather than round and the entire outer edge of the outsole was extended so that it was in line with a perpendicular dropped from the boot upper; and (2) the heel was made larger and pushed back so that the back edge was almost in line with the boot upper. The same sock lining and outsole design as that of Prototype pair R-3001-13,-14 was used. The outsole was made larger to reduce skin punctures from objects which could come in contact with the side of the boot - a deficiency which was noted on Prototype pair R-3001-13,-14. Formulations for each integral part of the boots and the typical physical properties are tabulated in Tables XIII and XIII A.

3. Prototype Pair R-3003-1,-2

Prototype pair R-3003-1,-2 was fabricated from the same mold as Prototype pair R-3002-1,2 and has the same overall design except that it has a nylon sock lining. The nylon sock lining was used instead of the Estane sock lining to improve the slip qualities of the sock lining and promote ease of donning and doffing. The nylon sock lining consists of a nylon fabric laminated to a cotton fabric with a natural rubber interface which is vulcanized after lamination. The nylon fabric which is used against the foot is a 100% nylon tricot having a weight of 2.7 ounces per square yard. This material is also known as Two Bar Jersey tricot net. The fabric used against the urethane foam is a 3-ounce ribbed, net cotton. The nylon against the foot has good slip qualities but poor adhesion to polyurethanes; therefore, the cotton fabric is required to obtain good adhesion to the polyurethane foamed upper. The vulcanized gum coat between the 2 fabrics prevents the liquid

NOT REPRODUCIBLE

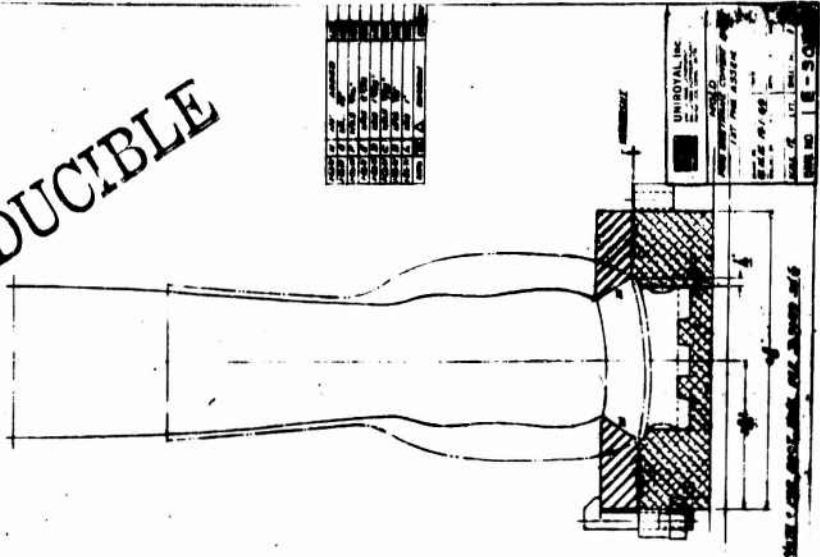
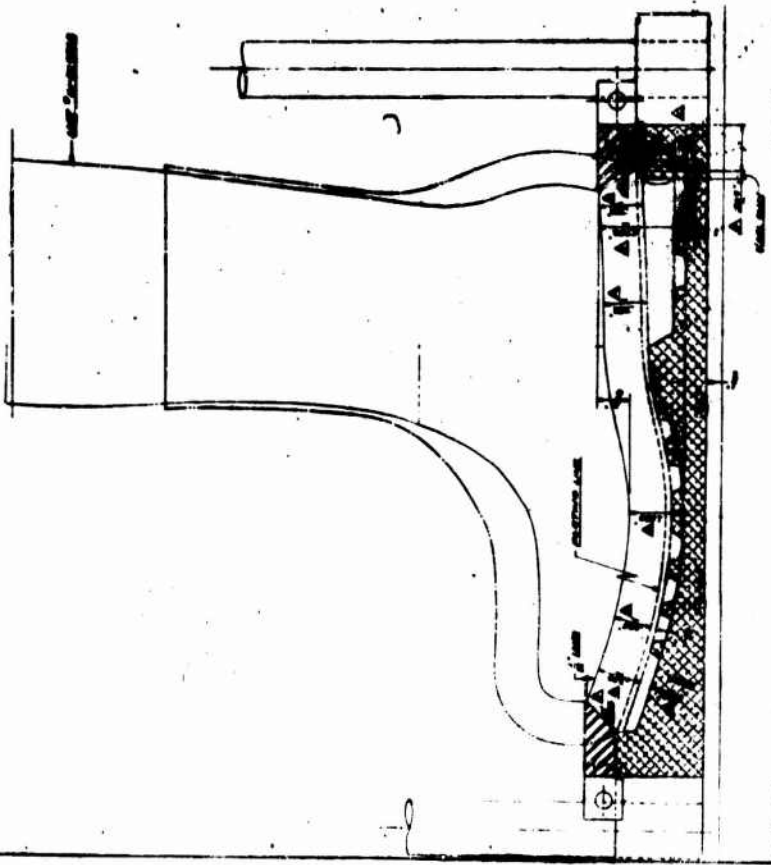
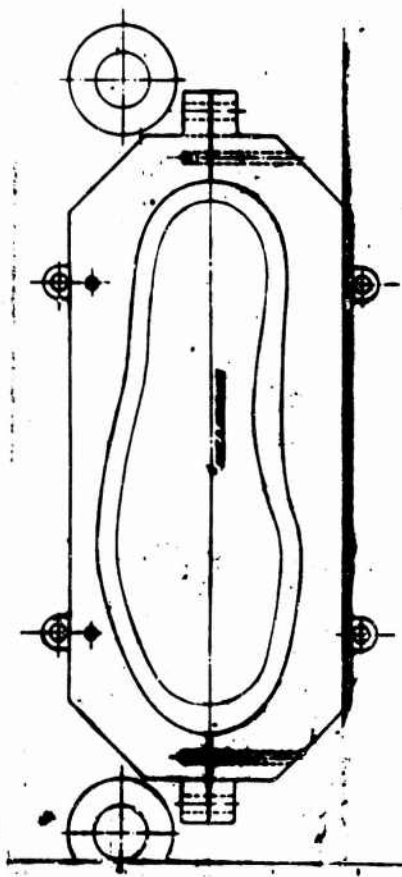

UNIROVAL, INC.
1717 W. 43RD ST.
MILWAUKEE, WIS. 53214
TEL. 441-8800
FAX 441-8800
REV. NO. 18-30

Mold for Urethane Combat Boot - First Fill Assembly, #E3089-1

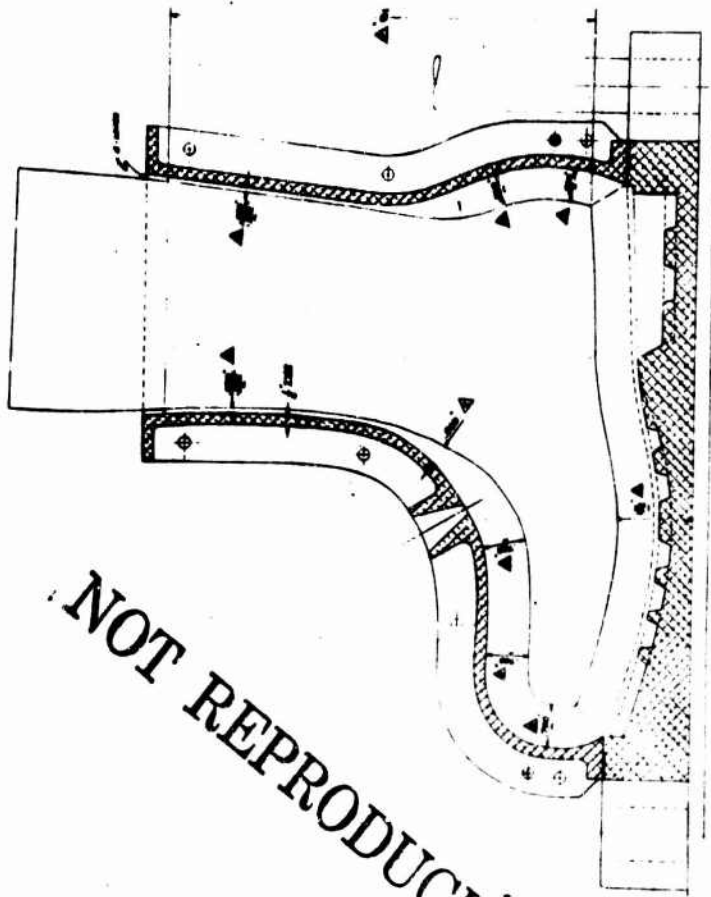
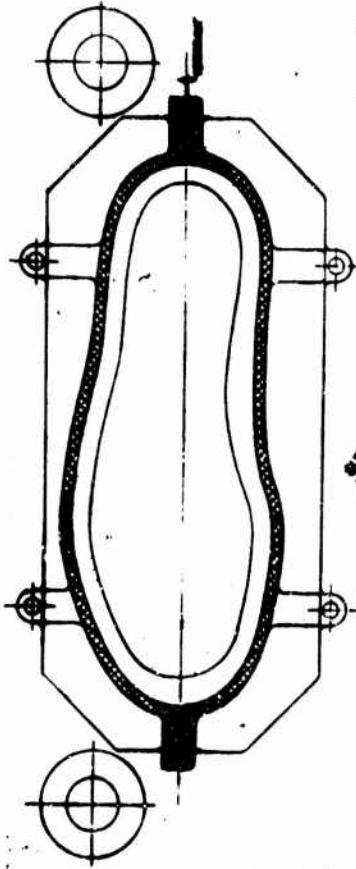

NOT REPRODUCIBLE

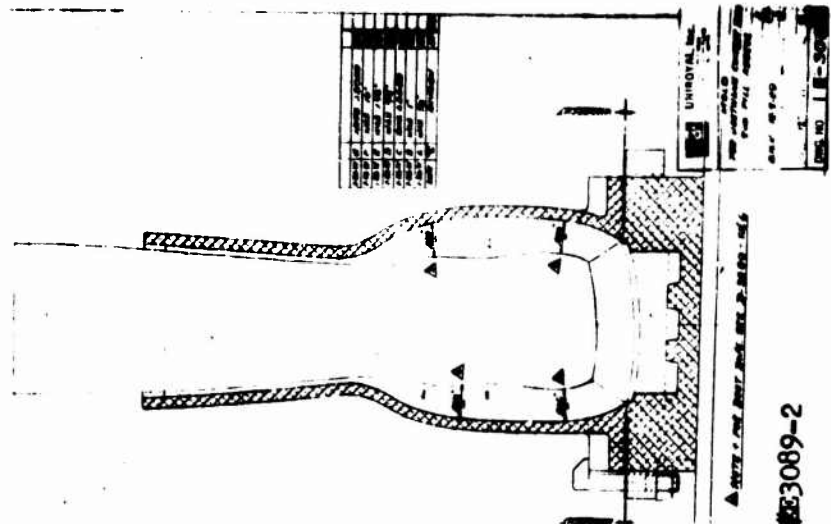

Mold for Urethane Combat Boot - Second Fill Assembly. #E3089-2

TABLE XII

PROTOTYPE BOOTS R-3001

Composition <u>Sock Lining (PHR)</u>	(A)		(B)		(3)		A ₁		(1)		(2)		(6)		(7)		(8)		(9)		(10)		(11)		(12)		(13)		(14)		
	Pair	Pair	Pair	Pair	Pair	Pair	Pair	Pair	Pair	Pair	Pair	Pair	Pair	Single Root	Pair	Pair	Pair	Pair	Pair	Pair	Pair	Pair	Pair	Pair	Pair	Pair	Pair	Pair	Pair	Pair	
Boot R-3001	100	100	100	100	100	100	100	100	100	100	100	100	100	100	100	100	100	100	100	100	100	100	100	100	100	100	100	100	100	100	100
Estane 5707	5	5	5	5	5	5	5	5	5	5	5	5	5	5	5	5	5	5	5	5	5	5	5	5	5	5	5	5	5	5	5
3041 Black	1430	1430	1430	1430	1430	1430	1430	1430	1430	1430	1430	1430	1430	1430	1430	1430	1430	1430	1430	1430	1430	1430	1430	1430	1430	1430	1430	1430	1430	1430	1430
THF (Solvent)	0.9	0.8	0.9	0.8	0.9	0.8	0.9	0.8	0.9	0.8	0.9	0.8	0.9	0.9	0.6	0.6	0.6	0.7	0.6	0.6	0.6	0.6	0.6	0.6	0.6	0.6	0.6	0.6	0.6	0.6	0.6
Weight (oz.)	100	100	100	100	100	100	100	100	100	100	100	100	100	100	100	100	100	100	100	100	100	100	100	100	100	100	100	100	100	100	100
<u>Outsole (PHR)</u>	100	100	100	100	100	100	100	100	100	100	100	100	100	100	100	100	100	100	100	100	100	100	100	100	100	100	100	100	100	100	100
Vitrahane B-602	10	10	25	10	25	25	25	25	25	25	25	25	25	25	25	25	25	25	25	25	25	25	25	25	25	25	25	25	25	25	25
Santizer S-140	4	4	4	4	4	4	4	4	4	4	4	4	4	4	4	4	4	4	4	4	4	4	4	4	4	4	4	4	4	4	4
MPDA	4	4	4	4	4	4	4	4	4	4	4	4	4	4	4	4	4	4	4	4	4	4	4	4	4	4	4	4	4	4	4
Santizer S-160	2	2	2	2	2	2	2	2	2	2	2	2	2	2	2	2	2	2	2	2	2	2	2	2	2	2	2	2	2	2	2
SF-1079 Silicone	0.7	0.7	0.7	0.7	0.7	0.7	0.7	0.7	0.7	0.7	0.7	0.7	0.7	0.7	0.7	0.7	0.7	0.7	0.7	0.7	0.7	0.7	0.7	0.7	0.7	0.7	0.7	0.7	0.7	0.7	0.7
Nitrosan	0.7	0.7	0.7	0.7	0.7	0.7	0.7	0.7	0.7	0.7	0.7	0.7	0.7	0.7	0.7	0.7	0.7	0.7	0.7	0.7	0.7	0.7	0.7	0.7	0.7	0.7	0.7	0.7	0.7	0.7	0.7
US-15N	2.1	2.1	2.1	2.1	2.1	2.1	2.1	2.1	2.1	2.1	2.1	2.1	2.1	2.1	2.1	2.1	2.1	2.1	2.1	2.1	2.1	2.1	2.1	2.1	2.1	2.1	2.1	2.1	2.1	2.1	2.1
3041 Black	11.5	9.4	9.5	9.2	11.8	10.4	10.6	10.0	9.2	9.5	9.2	11.4	9.2	11.4	9.2	9.5	9.2	11.4	9.2	11.4	9.2	11.4	9.2	11.4	9.2	11.4	9.2	11.4	9.2	11.4	9.2
Weight	11.5	9.4	9.5	9.2	11.8	10.4	10.6	10.0	9.2	9.5	9.2	11.4	9.2	11.4	9.2	9.5	9.2	11.4	9.2	11.4	9.2	11.4	9.2	11.4	9.2	11.4	9.2	11.4	9.2	11.4	9.2

TABLE XII (Cont'd)

PROTOTYPE BOOTS R-3001

Composition Upper (PHR)	(A	(B	(3	(A ₁)	(1	(2)	(6	(7	(8)	(9	(10)	(11	(12)	(13	(14)
	Pair	Pair	Pair	Pair	Pair	Pair	Single Boot	Pair	Pair	Pair	Pair	Heavy Skin Pair	Heavy Skin Pair	Prototype Pair	Prototype Pair
Boot R-3001-	100	100	100	100	100	100	100	100	100	100	100	100	100	100	100
Vibrathane B-602	40	40	25	40	25	25	25	25	25	25	25	25	25	25	25
Santicizer S-140	4	4	4	4	4	4	4	4	4	4	4	4	4	4	4
MPDA	4	4	4	4	4	4	4	4	4	4	4	4	4	4	4
Santicizer S-160	2	2	2	2	2	2	2	2	2	2	2	2	2	2	2
SF-1079 Silicone	7	7	7	7	7	7	7	7	7	7	7	7	7	7	7
Nitrosan	3	3	3	3	3	3	3	3	3	3	3	3	3	3	3
US-15N	3	3	3	3	3	3	3	3	3	3	3	3	3	3	3
Weight (oz.)	7.6	7.8	7.8	7.1	7.8	8.1	8.8	7.7	7.2	7.2	5.8	7.4	8.0	7.6	7.2
Outer Skin (PHR)															
Vibrathane P-605	100	100	100	100	100	100	100	100	100	100	100	100	100	100	100
Toluene	200	200	200	200	200	200	200	200	200	200	200	200	200	200	200
MPDA	3.8	3.8	3.8	3.8	3.8	3.8	3.8	3.8	3.8	3.8	3.8	3.8	3.8	3.8	3.8
THF	51.2	51.2	51.2	51.2	51.2	51.2	51.2	51.2	51.2	51.2	51.2	51.2	51.2	51.2	51.2
Santicizer S-140	40	40	40	40	40	40	40	40	40	40	40	40	40	40	40
3041 Black	5	5	5	5	5	5	5	5	5	5	5	5	5	5	5
Weight (oz.)	3.7	2.6	3.0	2.8	3.2	2.9	2.1	2.6	2.8	2.9	4.4	6.0	5.0	3.0	2.6
Total Boot Weight (oz.)	23.7	20.6	21.2	19.9	23.7	22.2	22.4	20.9	19.9	20.2	20.0	25.4	22.9	21.0	21.2

TABLE XII A

TYPICAL PHYSICAL PROPERTIES OF PROTOTYPE BOOTS R-3001

Physical Properties	Upper	Lower
<u>Physical Properties</u>		
<u>Socket Lining</u>		
100% Modulus (PSI)	2000	3300
300% Modulus (PSI)	3500	5800
Tensile Strength (PSI)	450	200
Elongation (%)	200	700
Trouser Tear (PPI)		
Die C Tear (PPI)		
	12	12
	5.5	47
	13.0	65
		440
		2
<u>Outsole</u>		
Density (lbs./cu.ft.)		28
25% Compression Deflection (PSI)		33.8
@ 70°F		45.0
@ -20°F		33
100% Modulus (PSI)		138
300% Modulus (PSI)		290
Tensile Strength (PSI)		550
Elongation (%)		5
Trouser Tear (PPI)		22
NBS Abrasion		
50% Compression Set		
(After 22 hrs. @ 158°F)		25%
(After 22 hrs. @ 70°F)		8%
25% Compression Set		
(After 22 hrs. @ -20°F)		100.0%
Reading after 10 sec.		92.5%
Reading after 30 min.		
Density (lbs./cu.ft.)		
25% Compression Deflection (PSI)		
@ 70°F		
@ -20°F		
100% Modulus (PSI)		
300% Modulus (PSI)		
Tensile Strength (PSI)		
Elongation (%)		
Trouser Tear (PPI)		
Die C Tear (PPI)		
Getman Test Data		
T ₂		
T ₅		
T ₁₀		
T ₁₀₀		
Outer Skirt		
100% Modulus (PSI)		
300% Modulus (PSI)		
Tensile Strength (PSI)		
Elongation (%)		
Trouser Tear (PPI)		
Die C Tear (PPI)		
Getman Test Data		
T ₂		
T ₅		
T ₁₀		
T ₁₀₀		

* Performed on outsole core, values determined on outsole skins.

TABLE XII B
INSULATION THICKNESS OF PROTOTYPE BOOTS R-3001

Upper Insulation Thickness* (.001 inch)

	<u>Side</u>	<u>Front</u>	<u>Back</u>
Top	70	70	70
Ankle	400	500	500
Heel	-	-	500
Instep	600	600	-
Toe	700	700	

Outsole Thickness - Includes cleats which are 250 mils thick

Heel	1750
Arch	750
Ball	1000

*Boots R-3001 - A, -1, -3 and -7 through -14

TABLE XIII

COMPOUND FORMULATIONS OF PROTOTYPE BOOTS

Prototype Boot	R - 3002		R - 3004		R - 3005		R - 3006		R - 3007	
	-1	-2	-1	-2	-1	-3	-2	-4	-1	-2
Sock Lining (PHR)										
Estane 5707	100	100								
3041 Black	5	5								
THF (Solvent)	1430	1430								
Weight (oz.)	0.4	0.4								
Outsole (PHR)										
Vibrathane B-602	100	100								
Santizer S-140	25	25								
MPDA	4	4								
Santizer S-160	4	4								
SF-1079 Silicone	2	2								
Nitrosan	0.7	0.7								
US-15N	0.7	0.7								
3041 Black	2.1	2.1								
Weight (oz.)	11.2	11.2								
Upper (PHR)										
Vibrathane B-602	100	100								
Santizer S-140	25	25								
MPDA	4	4								
Santizer S-160	4	4								
SF-1079 Silicone	2	2								
Nitrosan	7	7								
US-15N	3	3								
Weight (oz.)	6.0	7.0								
Outer Skin (PHR)										
Vibrathane B-605	100	100								
Toluene	200	200								
MPDA	3.8	3.8								
THF	21.2	21.2								
Santizer S-160	40	40								
3041 Black	5	5								
Weight (oz.)	3.6	3.6								
Total Boot Wt. (Oz.)	21.2	24.2	25.8	27.0	26.8	25.8	24.8/27.2	24.8/27.2	25.8	24.8

TABLE XIII A

TYPICAL PHYSICAL PROPERTIES FOR PROTOTYPES R-3002 THROUGH R-3007

<u>Upper</u>				
Density (lbs/cu. ft.)	2000			12
25% Compression Deflection (PSI) @ 70°F	3500			5.5
	5800			13
100% Modulus (PSI)	450			12
300% Modulus (PSI)	200			47
Tensile Strength (PSI)	700			65
Elongation (%)				440
Trouser Tear (PPI)				2
Die C Tear (PPI)				
<u>Cutsole^b</u>				
Density (lbs/cu. ft.)	28			
25% Compression Deflection (PSI) @ 70°F	33.8			68%
	45.0			0%
	33			96.4%
100 % Modulus (PSI)	138			94.2%
300% Modulus (PSI)	200			
Tensile Strength (PSI)	550			
Elongation (%)	5			
Trouser Tear (PPI)	22			
NBS Abrasion ^c				
50% Compression Set (After 22 hrs. @ 158°F)				
(After 22 hrs. @ 70°F)				
25% Compression Set (After 22 hrs. @ -20°F)				
Reading after 10 sec.				
Reading after 30 mins.				
Outer Skin				
100% Modulus (PSI)	360			
300% Modulus (PSI)	800			
Tensile Strength (PSI)	2840			
Elongation (%)	25%			
Trouser Tear (PPI)	8%			
Die C Tear (PPI)				
	100.0%			
	92.5%			

a) Only for prototype pair R-3002-1,-2. Others have stitched fabric

b) Does not include prototype pair R-3006-1,-2 since outsole compound is same as upper compound

c) Performed on outsole core

polyurethane from coming through to the nylon sock and nullifying the good slip finish when the boot is being fabricated. The formulations for each integral part of the boot and the typical physical properties of these parts are tabulated in Tables XIII and XIII A.

4. Prototype Pair R-3004-1,-2

Prototype pair R-3004-1,-2 was identical to prototype pair R-3003-1,-2 except that it had a counter which was integrally cast with the outsole. This counter was added to render support to the heel of the foot and to stabilize the foot so that it did not shift off the edge of the outsole. The formulations for each integral part of the boot and the typical physical properties of these parts are tabulated in Tables XIII and XIII A.

5. Prototype Pairs R-3005-1,-2,3,-4

Prototype pairs R-3005-1,-2,3,-4 were identical to prototype pair R-3003-1,-2 except that the outsole design was altered to look like Design E in Figure 18. This new outsole design was used to increase the wear surface of the outsole in the area of the ball of the foot. The formulations for each integral part of the boots and the typical physical properties of these parts are tabulated in Tables XIII and XIII A.

6. Prototype Pair R-3006-1,-2

Prototype pair R-3006-1,-2 was also identical to prototype pair R-3003-1,-2 except that the formulation for the upper foam insulation was used for both the outsole and the upper foam insulation. Another exception was that the outsole design was that of Design E which is illustrated in Figure 18. These changes were made so as to determine the feasibility of the low density upper foam insulation as an outsole material. This low density foam accounted for a considerable weight reduction in the boot and also a softer feeling outsole. The formulations for each integral part of the boot and the typical physical properties of these parts are tabulated in Tables XIII and XIII A.

7. Prototype Pair R-3007-1,-2

Prototype pair R-3007-1,-2 was identical to prototype pair R-3003-1,-2 except that a four inch high nylon closure with a draw lace at the top was attached to each boot. The nylon material used for this closure was identical to the nylon material used for the sock lining. The closure was added to seal off the top edge of the boot from the elements of the weather. The formulations for each integral part of the boot and the physical properties of the parts are tabulated in Tables XIII and XIII A.

F. Informal Information on Additional Pairs of Prototype Boots R-3001-13, -14 and R-3003-1,-2

During the month of March, 1970 the first prototype pair (R-3001-13, -14) of lightweight, insulated polyurethane boots was submitted to the U.S. Army Natick Laboratories. Also, six similar pairs were prepared. The

formulations for each integral part of the boot and the physical properties of these parts are tabulated in Tables XII, XIIA & XIIB. These formulations represented the best overall formulations to date which would provide boots with adequate physical properties. Two pair of the above boots were wear tested in Alaska by the U. S. Army Natick Laboratories. The limited data obtained from the test promoted design changes which resulted in the fabrication of Prototype pair R-3003-1,-2.

Prototype Pair R-3003-1,-2 served as a model for the production of 50 additional pairs of boots. The weight of these boots averaged about 26 ounces/boot. The slight increase in weight was a result of increased materials used in the boot which had a slightly larger outsole and upper and also a result of altered processing conditions. The increased volume of each boot accounted for approximately 2 ounces of additional weight. The use of a nylon/rubber/cotton laminate as a sock lining added an additional one ounce of weight.

It was essential that the last and the mold be heated together to approximately 230^oF prior to casting the liquid polyurethane. Since the nylon sock acts as an insulator and prevents the heat transfer from the last to the compound from not being as efficient as the heat transfer from the mold to the compound, the overall expansion of the compound is decreased and results in a slightly higher density boot. This increased density accounted for approximately two more ounces of additional weight per boot.

To compensate for the insulating effect caused by the nylon sock, the mold and last were heated to a higher temperature (250^oF). However, since both mold and last must be heated together, the added heat transmitted by the mold results in over expansion and the resulting compound was too soft and lacked durability. On the other hand, if the mold is not heated to higher temperatures, but rather more blowing agent is added to the compound, the expansion of the compound is more violent and the foam contains many cells which have ruptured thereby producing an open cell structure. These results indicated that the balance between temperature and blowing agent was critical and in order to maintain optimum compound properties, the increased weight of the boot must be accepted.

To prevent delamination of the sock lining from the upper foam insulation at the top edge of the boot, the top edge of the boot was dipped in the outer skin compound prior to spraying to form a seal between the sock lining and upper foam insulation. This procedure was adapted in fabricating the 50 pair of boots to insure the adhesion of the sock lining to the upper foam insulation.

The compositions of all of the integral parts of these boots are the same as the compositions of all of the integral parts of Prototype pair R-3003-1,-2 and are listed in Table XIII. The typical physical properties of these boots are listed in Table XIV. These physical properties were determined from actual boot parts. The dissection of the boots was very critical. No sample of the outer skin large enough to subject to stress/strain measurements could be successfully removed from the upper foam insulation. A meat slicing machine was used to cut the outsole and upper insulation foam into proper sample thicknesses for each test described in Table XIV.

TABLE XIV

TYPICAL PHYSICAL PROPERTIES OF 50 PAIR OF PROTOTYPE BOOTS R-3003

<u>Physical Properties</u>	<u>Outsole</u>	<u>Upper</u>	<u>Skin</u>
Density (lbs./cu.ft.)	19.6	11.8	-
25% Compression Deflection (PSI) @ 70°F	21.4	4.8	-
25% Compression Deflection (PSI) @ -20°F	120	13.1	-
100% Modulus (PSI)	25	10	360
300% Modulus (PSI)	125	45	800
Tensile Strength (PSI)	245	55	2840
Elongation (%)	500	425	570
Trouser Tear (PPI)	5	2	22
AKBS Abrasion	9
<u>25% Compression Set</u>			
After 22 hours @ 158°F	17.8	83.3	..
After 22 hours @ 70°F	21.5	15.0	..
Water Absorption (%)	27.0	13.5	..

Per Unit of Surface Area

G. Conclusions

- 1) Serviceable, lightweight, insulated footwear having good low temperature flexibility can be fabricated from the developed polyurethane compounds and process.
- 2) Foot insulation test data indicate that the produced footwear have adequate overall insulation.
- 3) The outsole wear and traction of the footwear has been improved by new outsole designs and compounds.
- 4) Redesigning of the last has resulted in snugger fitting footwear and has eliminated slippage at the counter.
- 5) The finalized boot design combined with a heavily sprayed outer skin at the edge of the outsole resulted in the production of durable footwear.
- 6) The nylon/rubber/cotton laminate used as a sock lining with the nylon side against the foot offers ease of donning and doffing and good adhesion to the polyurethane foam upper.

ACKNOWLEDGEMENTS

The author wishes to acknowledge the efforts and assistance rendered by the following UniRoyal personnel: Arjo P. H. van der Meer, Edward J. Kopka, and Samuel F. Coleman from Research & Development; Conrad S. Rohs from Product Design; John B. Post from Style & Design; John H. Boland from Mechanical Engineering; Henry O. ... from Quality Assurance. The contributions made by these people were significant in fulfilling the objectives of this project.

APPENDIX
LIST OF MATERIALS

<u>MATERIAL (Trade Name)</u>	<u>CHEMICAL NAME</u>	<u>SOURCE</u>
Benzoflex 9-88	dipropylene glycol dibenzoate	Velsicol Chemical Corp.
3041 Black	flurane black dispersed in DOP	Inmont Corp.
1,4 - Butanediol	1,4-butanediol	GAF Corp.
DBEA	dibutoxy ethyl adipate	Reichold Corp.
DOZ	di-2-ethylhexyl azelate	Hatco Div. of Grace Chemical Co.
E-181 (Ansul Ether)	triethylene glycol dimethyl ether	Ansul Co.
Estane 5707	thermoplastic, polyester urethane	B.F.Goodrich Chemical Co.
L-5310 Silicone	silicone surfactant	Union Carbide Corp.
L-5410 Silicone	silicone surfactant	Union Carbide Corp.
MDA	methylene dianiline	The Dow Chemical Co.
mPDA	meta phenylene diamine	Miller-Stephenson Chemical Co., Inc.
Methylene Chloride	methylene chloride	Hubbard-Hall Chemical Co.
Nitrosan	N,N'-dinitroso-N,N'-dimethyl terephthalamide	E.I. DuPont DeNemours & Co., Inc.
pPDA	para phenylene diamine	American Hoechst Corp.
S-6531 Silicone	silicone surfactant	Dow Corning Corp.
SF-1079	silicone surfactant	General Electric
Santicizer S-140	cresyl diphenyl phosphate	Monsanto Chemical Co.
Santicizer S-160	butyl benzyl phthalate	Monsanto Chemical Co.

APPENDIX 4 (Cont'd)
LIST OF MATERIALS

<u>MATERIAL (Trade Name)</u>	<u>CHEMICAL NAME</u>	<u>SOURCE</u>
THF	tetrahydro furan	Quaker Chemical Co.
Toluene	toluene	AMSCO, Div. of Union Oil Co.
TP-95	dibutoxyethoxy ethyl adipate	Thiokol Chemical Corp.
US-15N (Escoflex 150)	secondary plasticizer	East Coast Chemical Co.
Vibrathane B-602	polyether, urethane prepolymer	Uniroyal Chemical Div.
Vibrathane B-605	polyether, urethane prepolymer	Uniroyal Chemical Div.

<u>FABRIC</u>	<u>DESCRIPTION</u>	<u>SOURCE</u>
300 Cotton Net	single thread ribbed net - 3.6 oz./sq.yd.	Lawrence Manufacturing Co.
1828 Nylon Tricot Net	two bar jersey tricot net - 2.7 oz./sq.yd.	Gehring Textile Co.