

AD735447

Technical Note N-1197

DEVELOPMENT OF AN ELEVATED CAUSEWAY - SURF TESTS

By

B. R. Karrh

November 1971

Approved for public release; distribution unlimited.

NAVAL CIVIL ENGINEERING LABORATORY
Port Hueneme, California 93043

Reproduced by
NATIONAL TECHNICAL
INFORMATION SERVICE
Springfield, Va. 22151

DDC
RECEIVED
JAN 18 1972
RECEIVED
C

UNCLASSIFIED

Security Classification

DOCUMENT CONTROL DATA - R & D		
<i>(Security classification of title, body of abstract and indexing annotation must be entered when the overall report is classified)</i>		
1. ORIGINATING ACTIVITY (Corporate author) Naval Civil Engineering Laboratory Port Hueneme, California 93043		2a. REPORT SECURITY CLASSIFICATION Unclassified
		2b. GROUP
3. REPORT TITLE DEVELOPMENT OF AN ELEVATED CAUSEWAY - SURF TESTS		
4. DESCRIPTIVE NOTES (Type of report and inclusive dates) Not final; July 1970 - December 1970		
5. AUTHOR(S) (First name, middle initial, last name) Billy R. Karrh		
6. REPORT DATE November 1971	7a. TOTAL NO. OF PAGES 27	7b. NO. OF REFS 6
8a. CONTRACT OR GRANT NO. b. PROJECT NO. YF 38.536.005.01.003 c. d.		9a. ORIGINATOR'S REPORT NUMBER(S) TN-1197
		9b. OTHER REPORT NO(S) (Any other numbers that may be assigned this report)
10. DISTRIBUTION STATEMENT Approved for public release; distribution unlimited		
11. SUPPLEMENTARY NOTES		12. SPONSORING MILITARY ACTIVITY Naval Facilities Engineering Command Washington, D. C. 20390
13. ABSTRACT Tests were performed to determine the feasibility of erecting an elevated pontoon causeway in the surf zone of an open beach. Ammi pontoons, measuring 90x28x5 feet, served as test vehicles. Techniques for installing an elevated causeway in a surf environment were evaluated; functions requiring refinement and/or further development were identified. Two independent tests were performed - one at the beach interface and one in 20 feet of water approximately 300 feet from shore. Estimates of time, manpower, and equipment required to erect an elevated causeway were derived from the experiment. The tests demonstrated that the operations required to install an elevated causeway are feasible in surf up to eight feet. Higher surf is likely to seriously degrade the effectiveness of operations.		

DD FORM 1473 (PAGE 1)
1 NOV 65

S/N 0101-807-6801

UNCLASSIFIED

Security Classification

DEVELOPMENT OF AN ELEVATED CAUSEWAY - SURF TESTS

Technical Note N-1197

YF 38.536.005.01.003

by

B. R. Karrh

ABSTRACT

Tests were performed to determine the feasibility of erecting an elevated pontoon causeway in the surf zone of an open beach. Ammi pontoons, measuring 90x28x5 feet, served as test vehicles. Techniques for installing an elevated causeway in a surf environment were evaluated; functions requiring refinement and/or further development were identified.

Two independent tests were performed - one at the beach interface and one in 20 feet of water approximately 300 feet from shore. Estimates of time, manpower, and equipment required to erect an elevated causeway were derived from the experiment. The tests demonstrated that the operations required to install an elevated causeway are feasible in surf up to eight feet. Higher surf is likely to seriously degrade the effectiveness of operations.

ACCESSION NO.	
UNCLASSIFIED	WHITE SECTION <input checked="" type="checkbox"/>
DDC	BUFF SECTION <input type="checkbox"/>
UNANNOUNCED	<input type="checkbox"/>
JUSTIFICATION	
BY	
DISTRIBUTION/AVAILABILITY CODES	
DIST.	AVAIL. and/or SPECIAL
A	

Approved for public release; distribution unlimited

UNCLASSIFIED

Security Classification

14 KEY WORDS	LINK A		LINK B		LINK C	
	ROLE	WT	ROLE	WT	ROLE	WT
Construction						
Pontoon causeways						
Surf zone						
Amphibious operations						
Materials handling						

TABLE OF CONTENTS

INTRODUCTION 1

TEST PROGRAM 1

 Test Equipment 2

 Test Setup 5

 Tests 5

 Near Shore Tests 5

 Offshore Tests 8

TEST RESULTS 8

DISCUSSION 13

FINDINGS AND OBSERVATIONS 21

CONCLUSIONS 25

REFERENCES 26

INTRODUCTION

There is a need for improvement to the follow-on logistics support of amphibious assaults. The basic requirement is to off-load cargo from deep draft ships to the shore. Techniques such as floating causeways, shuttle ferries, high lines, helicopters and various types of landing craft have been used in the past. A program to develop the capability to off-load deep-draft ships at open beaches, in undeveloped areas, and at damaged ports is being studied by the Naval Facilities Engineering Command (NAVFAC) under the title of the Expeditionary Logistics Facility (ELF). The development of the Ammi pontoon, which has the capability of being elevated on piles driven through spud wells in the deck, directed attention to the possibility of erecting an elevated causeway from the shore to an off-loading platform at sea. This report describes tests performed to develop information relevant to the establishment of an elevated causeway at an open beach area and to determine the significant parameters of such an operation.

TEST PROGRAM

The test program served to evaluate the feasibility of using the jack-up capability of the Ammi pontoon as one method for erecting an elevated causeway. Installation and retrieval techniques were tested. Two Ammi pontoons were installed during the tests - one at the beach, the other about 300 feet off shore in 20 feet of water. The information derived from the test program included the following: identification of problems of beaching and mooring an Ammi causeway, driving piles, elevating pontoons, and installing pontoons in deep water; estimates of limiting sea and surf conditions for performing the various installation operations; and estimates of the time and manpower required to erect an elevated causeway.

In formulating the test program it was concluded that the desired information could be obtained by performing two discrete tests - one at the beach and one in deeper water. The rationale for this was that the same basic operations are required for most of the intermediate causeway sections. Three basic installation sequences were considered:

1. The causeway string has one end beached and is moored on site.
 - (a) All sections remain connected until pile driving is complete; crane returns to the beach via the causeway; disconnecting and elevating of individual sections

follows. Or, as an alternative

- (b) each section is disconnected and elevated successively after piles are driven for it; the crane is transferred from the last (seaward) section onto a lighter.

2. The causeway string is beached and moored on site. Piles are driven for the pontoon on the beach; then the causeway string is disconnected and moved seaward where piles are driven for the pontoon nearest shore; each section is elevated after the piles are driven. The sequence is repeated until all piles are driven, then the crane is transferred onto a lighter at the last pontoon.

3. The causeway sections are brought in individually and moored in position where piles are driven and sections are elevated; crane is moved from section to section via lighter if sections are separated (for bridging units, perhaps).

Note that in sequence 1, the system has the use of the causeway as a pier throughout the installation; whereas, sequences 2 and 3 permit the option of spacing the sections for bridge units between them.

The selected tests are directly related to sequence 3, but the operations represent a common enough base to extrapolate test results to sequences 1 and 2. The significant operation not included in the tests is the elevation of two adjacent pontoons with overlapping ball-and-socket type end connectors, which applies to sequence 1. Previous tests experienced problems in elevating pontoons immediately adjacent to each other.¹ Then, the problem was resolved by jacking against the pontoons and by pulling on the driven piles to deflect them.

Test Equipment

The tests required the use of heavy equipment and hardware to support the operation. The NCEL warping tug, a flat-bottomed, sea going unit, was used to tow and maneuver the pontoon sections. A 50-ton truck crane was mounted aboard one section and an auxiliary pontoon section was utilized as a work platform to support the test. A rubber tired tractor and two bulldozers (D-8 and D-6) were used alternately as beach mooring points. An MKT DE-20 diesel pile hammer (16,000 foot-pounds energy) with swinging leads, shown in Figure 1, was used to drive the 20-inch diameter piles. To elevate the pontoon section on the four corner piles, a 12-part block and tackle gear (NAVFAC Drawing No. 1196232) was used with pile caps that were set in the end of each pile. The two bulldozers provided the driving force to operate the block and tackle gear. A large gasoline-engine driven winch was mounted on the auxiliary pontoon to provide the lifting force, but it was unusable when the surf was breaking over it (Figure 2). Other rigging gear was provided as required.

NOT REPRODUCIBLE

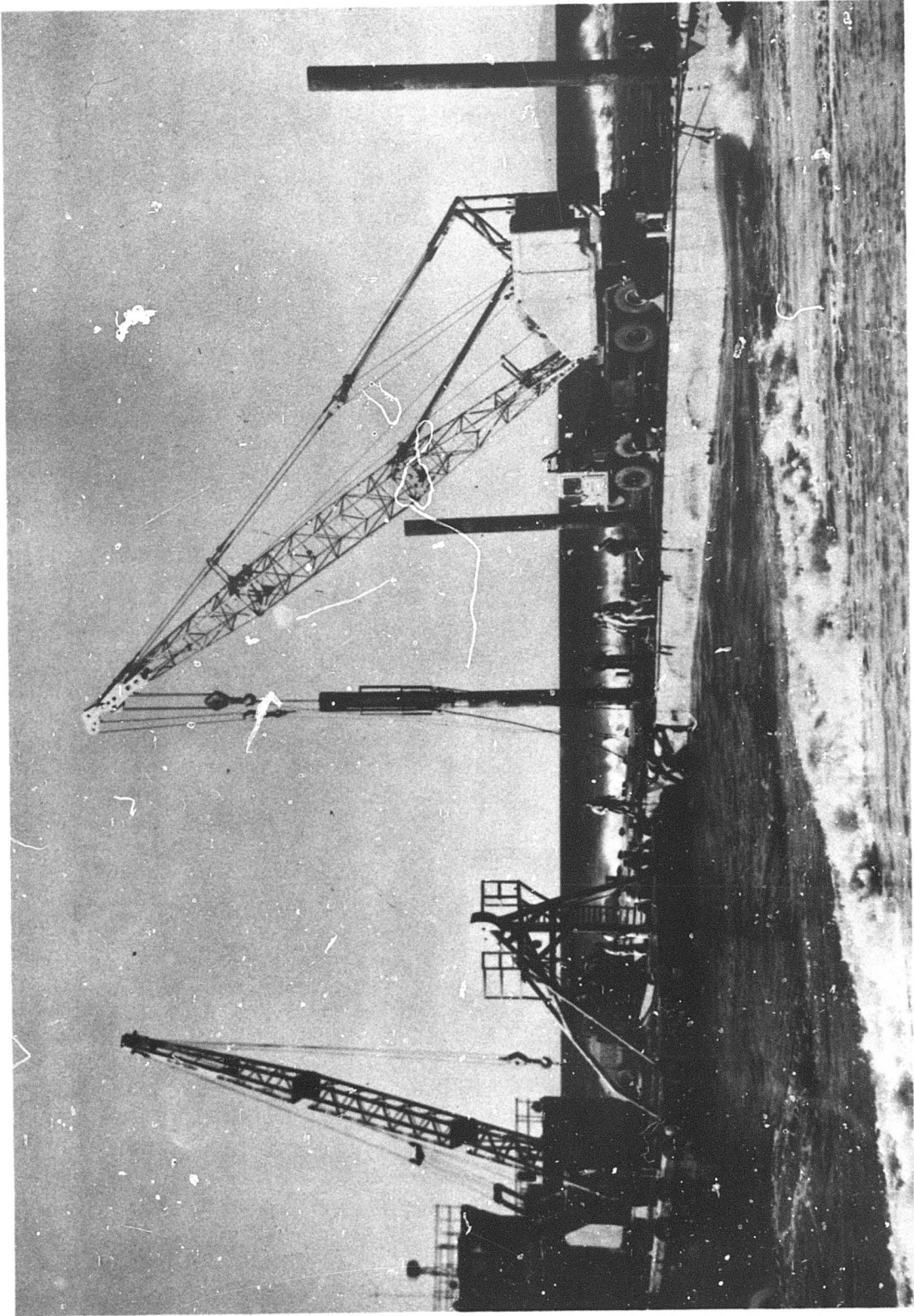

Figure 1. DE-20 diesel pile hammer with swinging leads for driving piles.

NOT REPRODUCIBLE

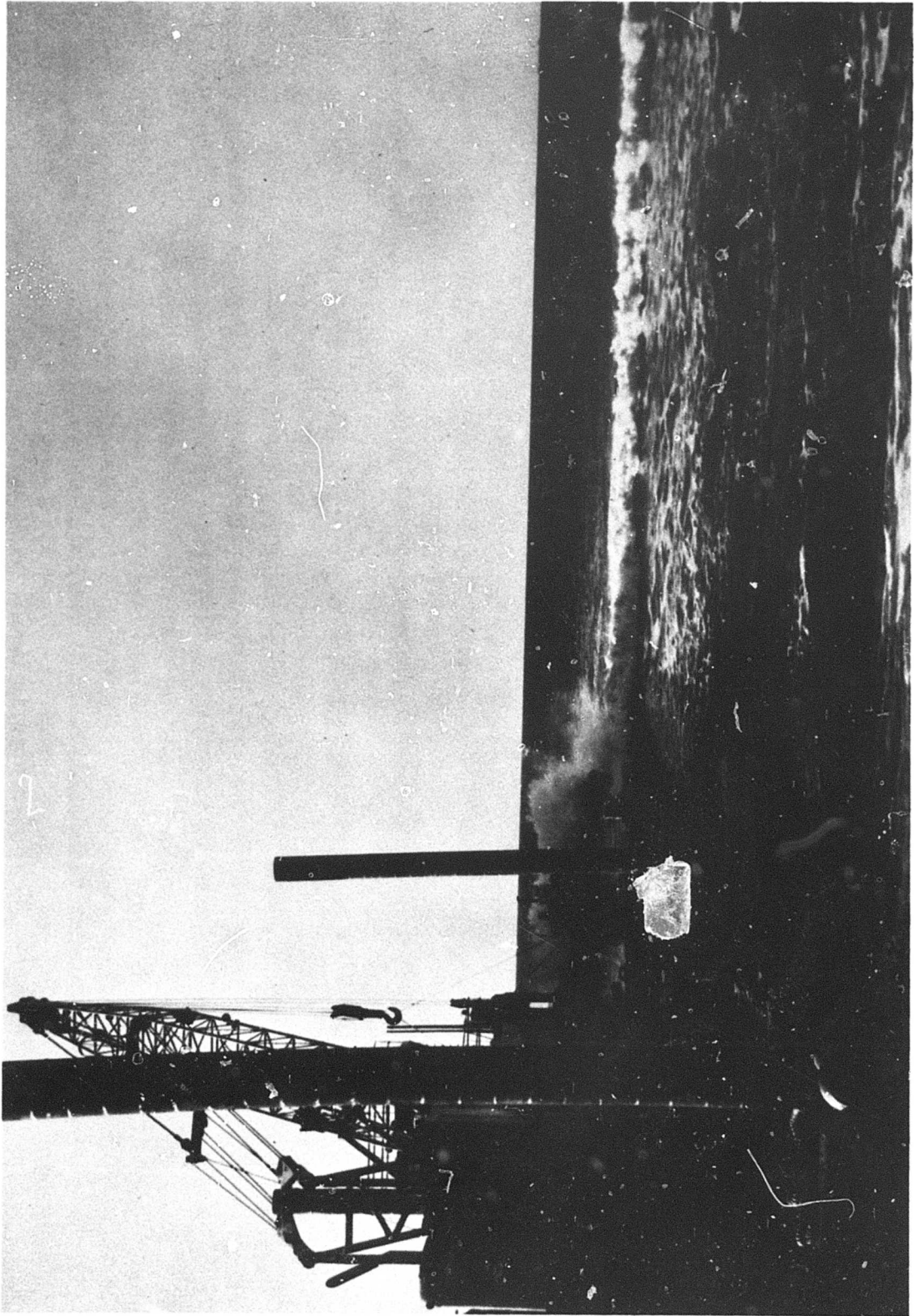

Figure 2. Surf breaking over pontoon and winch mounted on deck.

Test Setup

The tests were devised to minimize the amount of time that the pontoon sections remained in the surf before being elevated. Therefore, the greater part of the rigging was done in the harbor before putting out to sea. To avoid handling the bulky 20-inch diameter piles while the pontoon was subjected to the surf, they were set in the spudwells beforehand with stops welded to hold them up, as may be noted in Figure 2. Once the pontoon section was moored in position, the piles could be dropped in place merely by cutting the stops. The pile hammer was set in a spudwell of the auxiliary pontoon section and lashed down during transit to the test site. The crane was lashed to the pontoon deck with chain and turnbuckles. The block and tackle gear was pre-strung with 5/8-inch wire rope to the pile caps for subsequent placing onto the top of the piles and attaching to padeyes on the pontoon.

Tests

The tests were conducted at an open beach site at Point Mugu, California. The beach slope near shore ranged from 1/15 to 1/20. The general bottom slope to about 1 mile offshore was approximately 1/60.

Near Shore Tests. The first attempt to install an elevated section at the beach was made on 4 December 1970. The approach to the beach with two connected pontoon sections lashed alongside the NCEL warping tug commenced at 0830 (Figure 3). Sea conditions were estimated as follows: offshore swell 2-3 feet at 15 second periods; surf 4-5 feet and 15 second period; wind negligible.

A rubber-tired tractor was on the beach to serve as a mooring point when the pontoons beached; however, the tractor was unable to maneuver itself into position to receive the mooring line for the pontoons. The landing was aborted and the warping tug and pontoons retreated.

A second approach to the beach was begun at 0940. The surf was estimated to have increased to 5-7 feet at 8-10 second periods. The warping tug beached the pontoons and a mooring line was attached to the rubber-tired tractor that was now in position. The warping tug then cast off the side-lashing in order to achieve a two-point moor of the two sections between the warping tug and the tractor on the beach. However, upon attempting this maneuver the warping tug began pulling the two pontoon sections off the beach together with the tractor. In the interest of safety the mooring line was released from the tractor and the pontoons pulled out to sea. No further attempts were made to beach and moor the pontoon with the rubber-tired tractor.

On 5 December a second attempt was made to install an elevated pontoon section on the beach. This time the two bulldozers were placed on the beach to receive mooring lines from the pontoons. Sea conditions were estimated as follows: Offshore swell 2 feet at 10 second periods; water choppy due to 15 mph wind blowing seaward; surf 3-5 feet at 10 second periods.

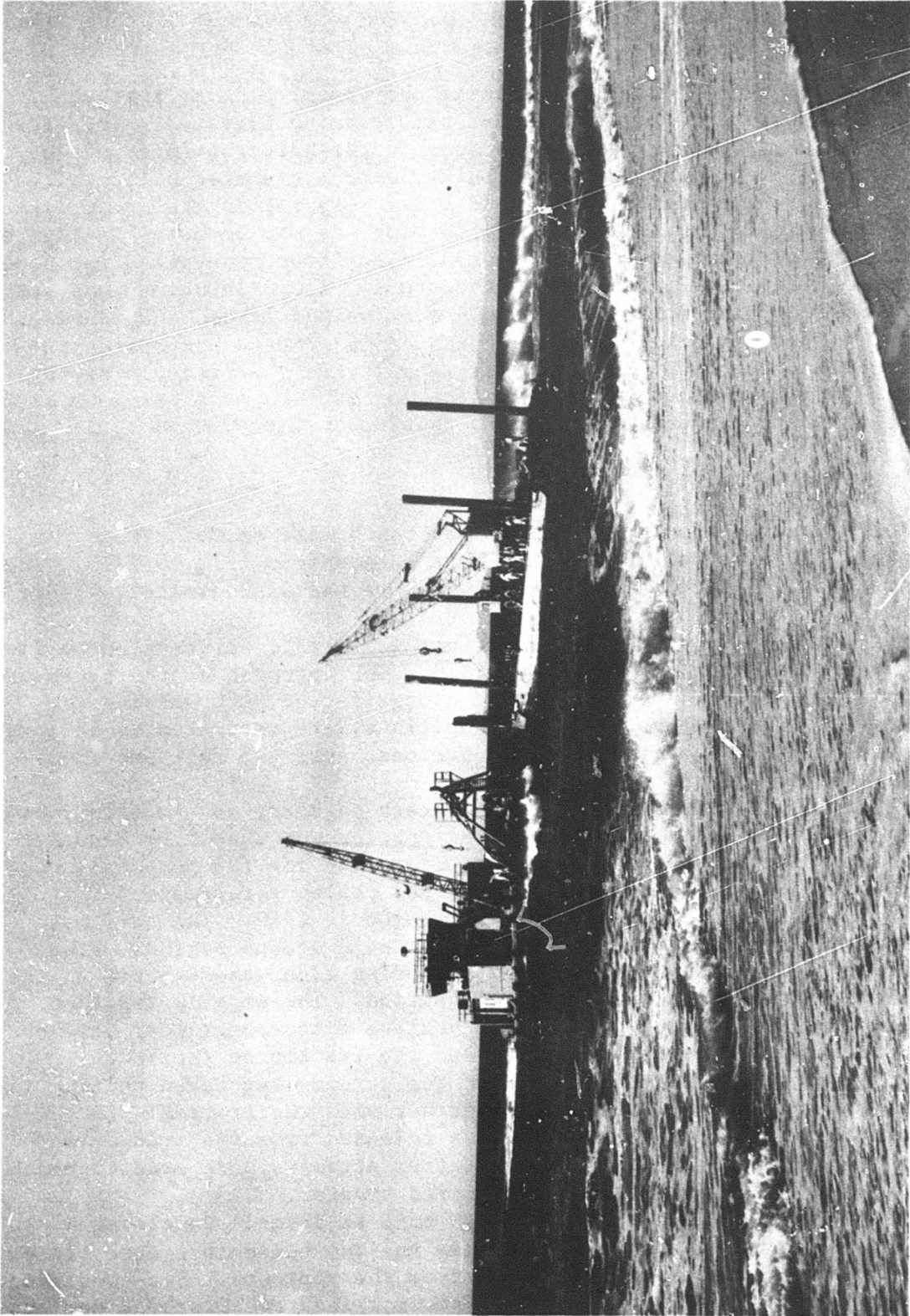

Figure 3. Approaching the beach for a test.

The approach to the beach by the warping tug and two pontoons lashed alongside began at 0845. The warping tug dropped its stern anchor to prevent broaching in the surf. At the beach a line was thrown to each of the tractors, where it was attached. The lines were pulled taut as the dozers moved along the beach. The warping tug remained alongside the pontoons during the test. Work began immediately to prepare for driving the piles. The stops were cut from the 30-foot long piles, allowing them to drop to the bottom. Outriggers on the crane were set and the pile hammer rigged and set in the first pile for driving. The only problem experienced was stabbing the pile with the hammer as the crane swayed due to the pontoon motion. Tag lines, as shown in Figure 4, were used to aid hammer placement. The piles were driven to a depth of 6 feet. (Shallow penetration was desirable to simplify retrieval.) The entire pile driving operation was completed within 25 minutes. It is estimated that all four piles could have been driven to a 15 or 20-foot penetration in 20 to 30 more minutes. Four men plus a crane operator handled the pile driving operation satisfactorily. The crane was lashed to the pontoon deck and conducted all operations from the one location. After the four piles were driven, the pile caps, pre-rigged with block and tackle gear, were set in the piles (Figure 5). This operation was completed within 20 minutes. Motion of the pontoon were not excessive when restrained by the driven piles.

The crane was then transferred to the adjacent pontoon section to permit the beached pontoon to be elevated. There was very little bending at the connection between the pontoons when the 50-ton crane rolled across (Figure 6). The auxiliary pontoon was disconnected in 30 minutes and removed from the test area by the warping tug.

To commence the lifting operation the dozers were positioned on the beach and a wire rope run from each of the four sets of block and tackle gear to the tractors as illustrated in Figure 7. The dozers then pulled slowly away lifting the pontoon. Minor adjustments were made in each line by taking up or letting off on a small winch on the tractors. The pontoon was elevated about six feet above the water level, as shown in Figure 8, to keep it above the water at high tide; elevating it to a higher level was not considered necessary to the test. The pontoon was elevated and secured in about 50 minutes. It could have been elevated higher at a rate of about 1 foot per minute.

Safety chains were installed to support the pontoon overnight. Six men, including 2 tractor operators were adequate to complete the elevation operation with the tractors. Several more men and time would have been required to lift the pontoon section with the Griphoist hand jacks described in reference 1.

On 6 December the pontoon was lowered to the water in 20 minutes by reversing the raising operation. After the lifting gear was secured the auxiliary pontoon (with the crane) was again connected to the pontoon and the crane transferred to the primary pontoon to remove the block and tackle gear, and to extract the piles. Connecting the two pontoons in the surf was a difficult task. Waves estimated up to six feet high were

breaking against the pontoons, impeding operations. The pontoon marriage took about 60 minutes. The piles which were driven to shallow penetration were pulled out by the crane in about 45 minutes. After pulling, the piles were locked in the spudwells in an upright position for transport back to the base. The total operation described above was completed in about seven hours working time.

Offshore Tests. On 9 December 1970, tests to install an elevated pontoon section in water depths of about 20 feet were conducted at the same test area. A strong onshore wind estimated at 18-20 mph was blowing onto the beach at an angle of about 60° to the shoreline. Wind generated waves of 3-4 feet offshore with 4-5 foot surf were estimated. Whitecaps were visible offshore and the sea was quite rough and choppy, with waves often throwing spray over the pontoon deck.

The pontoons were towed to the site as in previous tests. Upon attempting to moor the pontoon perpendicular to the beach, the wind, waves and along-shore current swept the pontoons and warping tug along the beach. The anchors could not be set to hold them in place. Consequently, the two pontoons and the warping tug were moored in the line of least resistance to the prevailing wind, waves, and current, roughly at a 60-degree angle to the beach. The mooring operation was completed in about 50 minutes. The water depth where the pontoons were moored varied from 18-20 feet. Figure 9 shows the moored configuration.

Procedures similar to those of the near shore tests were followed to drive the piles. Because of the water depth, 47-foot long piles were used. The welded stops which held the piles in the spudwells were cut off to allow the piles to drop. In the two point moor, the pontoon sections tended to sway somewhat in the wind and waves and it was no simple matter to maintain the piles in a vertical attitude once they were dropped to the ocean floor. There was considerable heave and pitch motion of the sections (estimated heave of more than two feet and pitch of about +2.50 degrees) which made it more difficult to handle and position the pile hammer. Again each pile was driven only to a shallow penetration; the total operation required about 25 minutes.

Since there was little information to be gained by elevating the section out of the water during this test, the operation was not performed. The remainder of the operation consisted of pulling the piles with the crane. Time required to pull the piles was about 80 minutes. After the piles were pulled, they were locked in the spudwells in an upright position for the return to port. One pile was damaged during the test.

TEST RESULTS

The results of the tests are summarized in Table 1. The operations performed, the installation sequences to which they apply, the men required, each operation's relationship to a full length installation, the execution time, and other pertinent remarks are presented in a tabular format. The basic test results are extrapolated to full scale operations in the discussion.

Table 1. Summary of Results.

Operation	Applies to Installation Sequence	Personnel Required	Time Required (hr)	Relation to Total Causeway Installation	Remarks
2 section causeway tow	1, 2, 3	Warping tug crew(s)	----	Similar to full causeway tow	Wind a significant deterrent
Beaching and mooring 2 section causeway	1, 2	Warping tug crew(s) 6 men, 2 dozer operators	1.00	Similar to real operation; more difficult with 2 section causeway	High wind, waves hinder operations; figure 10 estimates limits.
Placement of 4 piles in spudwells	1, 2, 3	1 crane operator, 4 men	0.25	Duplicates real operation; larger piles required for deep water	Long heavy piles will be more difficult to handle.
Vertical pile orientation	1, 2, 3	1 crane operator, 4 men	----	Duplicates real operation	Not executed for tests. Difficult operation with no fixed references; may require rigging if crane can't keep pile vertical during driving operation.
Hammer placement and driving (4 piles)	1, 2, 3	1 crane operator, 4 men	0.50	Duplicates real operation but piles would be driven deeper	Placement requires skilled crane operator.
Block and tackle gear, pile cap placement	1, 2, 3	1 crane operator, 4 men	0.50	Different lift system most likely to be used	Placing cap in pile requires skilled operator from moving pontoon.
Crane transfer to work barge	1(b), 2, 3	1 crane operator, 4 men	<0.50	Same as crane transfer; similar operation between pontoons	No significant problems.
Marry work barge to pontoon in surf	1(b), 2, 3	Warping tug crew, 6 men	1.00	Lighter married to offshore end of causeway to transfer crane	Operation very difficult in active surf, especially with Ammi chain connection.
Disconnect work barge in surf	1(b), 2, 3	Warping tug crew, 6 men	0.50	Lighter disconnected from causeway during crane transfer operation	Operation difficult in active surf, especially with Ammi chain connector.
Elevate pontoon	1, 2, 3	2 dozer operators, 4 men	0.25	Different lift system likely to be used	Elevating by block and tackle with dozers used to expedite tests; dozer method not generally recommended.
Install temporary suspension	1, 2, 3	4 men	0.50	Suspension system may differ	Chain hangers on pile cap used; turnbuckles required to equalize load on each chain.
Permanent connection	1, 2, 3	4 welders 4 helpers	1.00	Specialty connection to be developed	Not executed in current test; prior tests of simple hanging connection.
Lower pontoons	1, 2, 3	2 dozer operators, 4 men	0.50	Different lift system likely to be used	Elevating by block and tackle with dozers used to expedite tests; dozer method not generally recommended.
Causeway retraction	1, 2, 3	Warping tug crew(s) 6 men	0.50	Similar to real operation	Does not include retrieval of mooring if required.

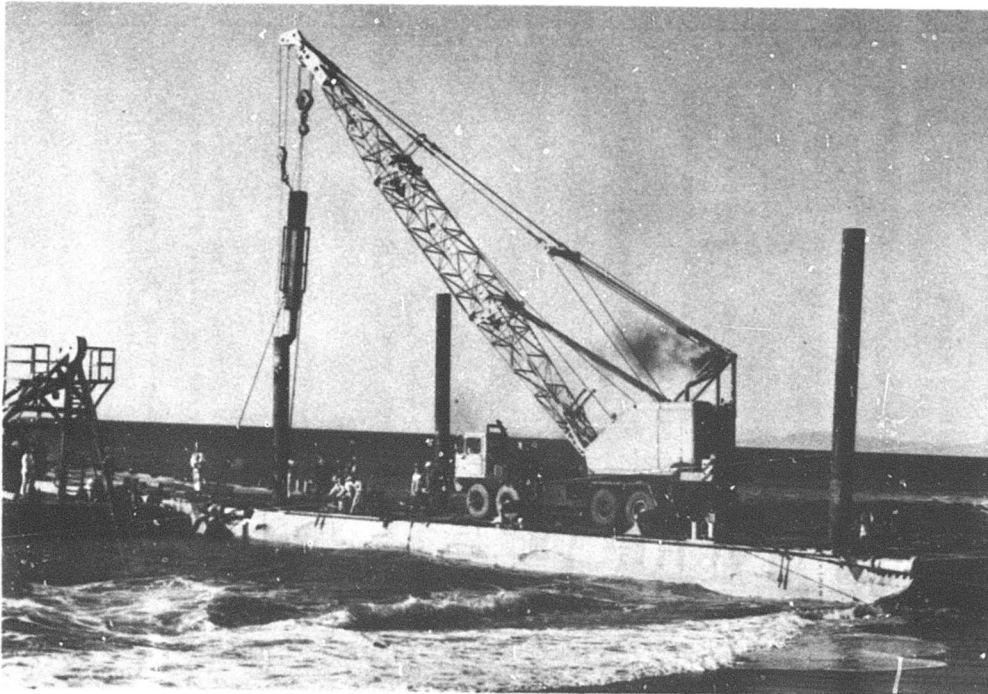

Figure 4. Tag lines to guide pile hammer into pile.

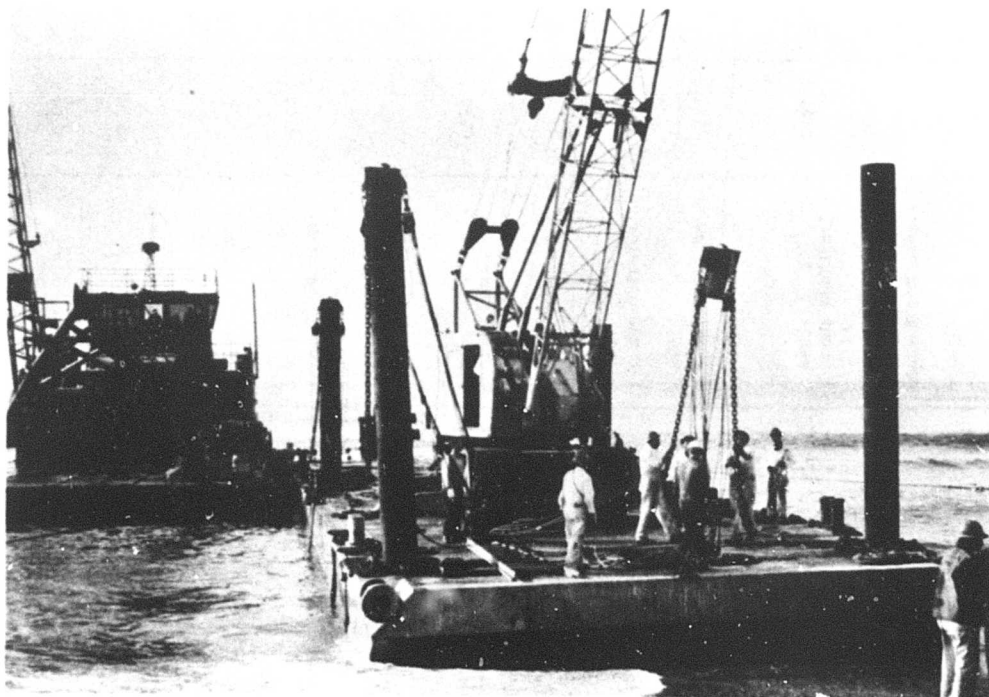

Figure 5. Placing pile caps, pre-rigged with block and tackle gear, atop the piles.

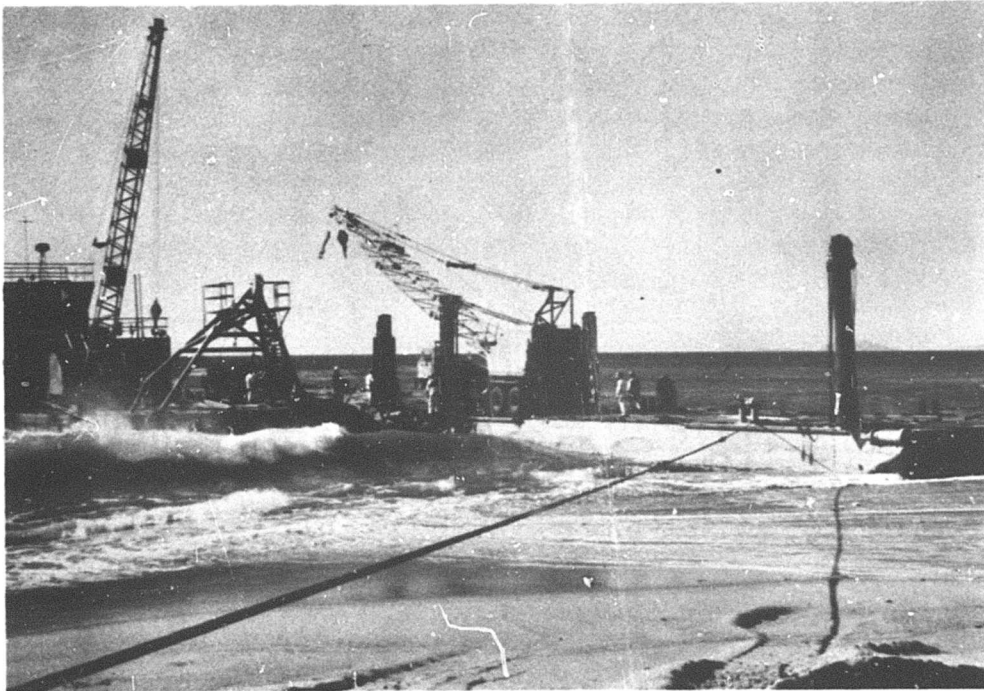

Figure 6. Transferring 50-ton crane to the auxiliary pontoon before elevating on piles.

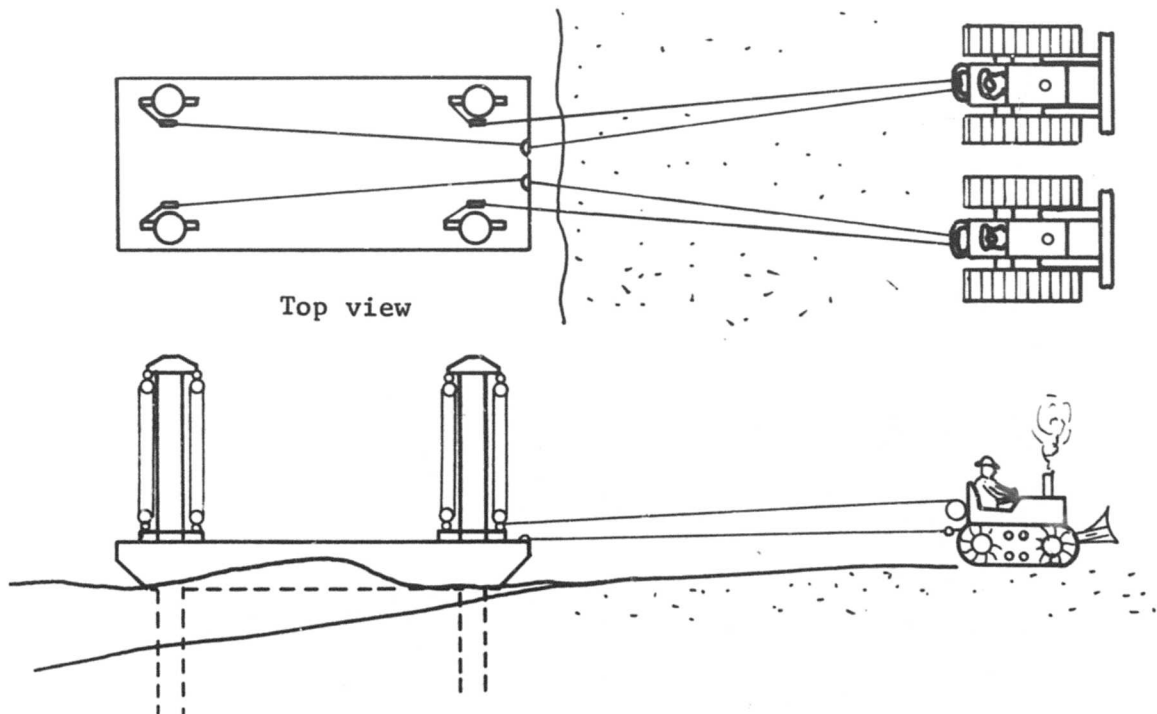

Figure 7. Technique for lifting pontoons with block and tackle gear and bulldozers.



Figure 8. Ammi pontoon lifted out of surf by block and tackle gear.

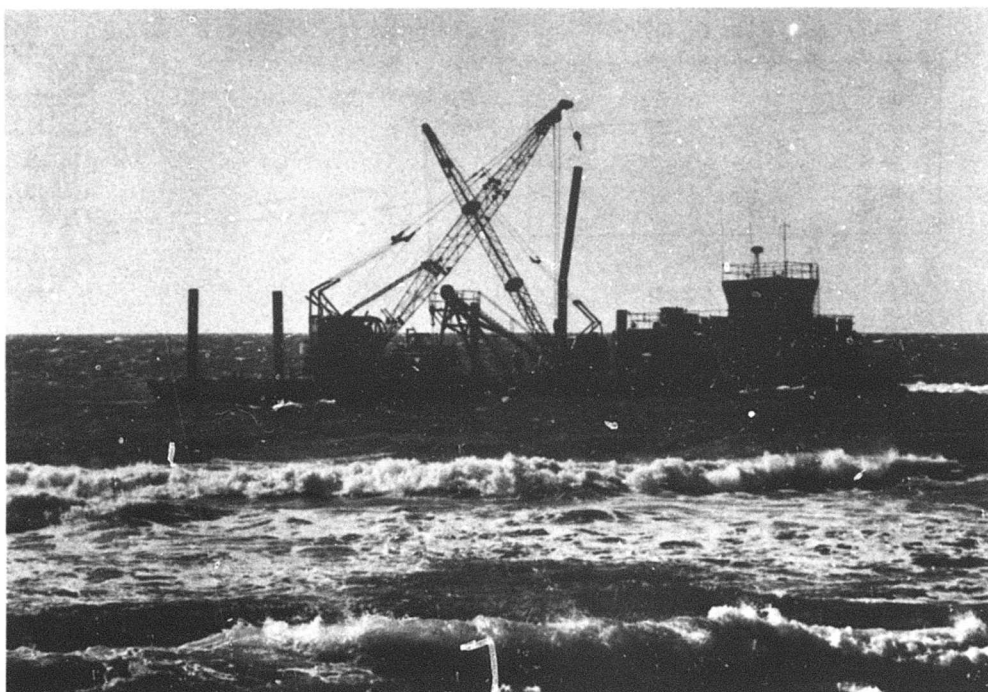

Figure 9. Moored position of warping tug and pontoons for offshore tests. Note pile damaged during tests.

DISCUSSION

The test program was devised to simulate operations required to install an elevated pontoon causeway. The Ammi pontoons used in the tests were considered as test vehicles to derive general information about the operations performed during installation. The Ammi is one of many possible causeway module configurations. Improvements to the basic elevated causeway module were suggested by the tests. The test program emphasized all significant operations of an elevated causeway installation, except mooring of a full length causeway, clearing ball and socket end connectors, and handling of large bulky piles in deep water. With the exception of large pile handling, the above operations have been investigated by previous tests, or in classic amphibious landings.

The elevated pontoon installation in shallow water provided information about the limiting conditions for similar operations on a full scale. Limiting surf conditions are relevant to two operational phases: (1) beaching and mooring the causeway and (2) operations associated with pile placement and driving. The beaching and mooring phase is critical in the surf zone, while pile placement and driving operations may be critical in deep water as well.

Surf conditions on 4 December were the most extreme experienced during the tests with breaking waves estimated up to seven feet. The beaching operation on this date was aborted when the rubber-tired tractor proved to be inadequate to moor the two section causeway. The causeway was actually beached, but had to be withdrawn when the tractor could not perform the mooring function. Apparently the operation would have been completed with adequate mooring equipment. It seemed likely that a full length causeway could have made the landing, though some waves might have topped the causeway deck. On 5 December the surf remained less than 6 feet during the beaching operation. Some waves threw spray over the end of the work barge as they broke against it, as may be noted in Figure 2. There was some concern about the 50-ton crane carried on one pontoon, but the pontoon remained stable throughout the landing. It is estimated that the extreme surf during which the causeway could have landed on the 1/15 beach is 8 feet with no wind. High winds make it difficult to maneuver a floating causeway. Reference 2 recommends limiting surf conditions for conducting amphibious landings and presents a method for modifying the surf for various wind conditions. The plot of Figure 10 estimates the maximum surf conditions for installing the causeway with various wind conditions. In general, steep beaches tend to amplify the surf effects.²

It is well known that pontoon motions degrade crane operations.³ In the case of an elevated causeway, motions are experienced in deep water as well as in the surf zone. Consider the possible motions of an end-to-end connected, floating causeway moored perpendicular to the beach. With one end resting against the beach, the causeway is restrained from longitudinal movement (surge) except for tolerance movement in the end connectors; this movement is random and should not permit excursions

greater than a few inches at any one location. Lateral movement of the causeway (sway) is restrained by mooring anchors and should be of minor consequence. The causeway is restrained from horizontal rotation (yaw) by the end connector geometry and the mooring system. Causeway rotation about the long axis (roll) may be experienced when oblique wave fronts hit the causeway; however, the end connector geometry tends to restrict roll by adjacent sections. Vertical motions (heave) are experienced by the causeway, but are partly restrained by the end connectors of adjacent pontoons. Causeway rotation about the short axis (pitch) occurs with individual pontoons because the end connectors allow free rotation and transmit only shear forces between pontoons. Therefore, heave and pitch are the predominant causeway motions which inhibit crane operations.

During the test, it was apparent that operator skill was a significant factor in crane operations. The operator must maintain his composure in the face of adverse circumstances. It was determined through model tests that heave response of a 22-foot wide Ammi pontoon causeway is greatest for long period, large amplitude waves, while pitch response is maximum for large waves in the 10-15 second period range.³ It seems reasonable to assume that most causeway modules would exhibit the same general response characteristics described above.

Pendulum motion (swinging) of a load at the crane hook amplifies the rigid body motion experienced by the crane and pontoon, as a result of heave and pitch, and makes operations more difficult. Figure 11 shows a plot of the natural period of a pendulum as a function of the pendulum length. If the predominant wave periods are in the range of the pendulum's natural period, then we would expect the swinging motion of the load to be amplified by the waves. When the wave period and pendulum period differ considerably, the swinging motion will be erratic and not so severe as when the periods are a near match. For example, consider a load on the hook with a 40-foot line. The natural pendulum period is about 7 seconds. Therefore, waves in the 6-8 second period range are likely to cause the greatest swinging motion of the load. Motions of a crane-hook load due to sea excitations are being investigated in a current study.⁵

The problems associated with deep water installation are related to pile placement and driving rather than beaching and mooring. This is true because offshore wave conditions are generally less severe than those in the surf zone. During the offshore tests, there were problems in placing the two section causeway in a two point moor because of high wind and waves. With a two-section causeway so difficult to maneuver by the warping tug in less than 20 knot winds, it is apparent that a long causeway would require several warping tugs to maneuver in high winds. Individual pontoon mooring applies only to the sequence 3 installation technique. A full length causeway is likely to be easier to moor because one end is landed on the beach to provide a stationary point, whereas, a single pontoon must be moored accurately without the benefit of a fixed point. Consequently, the sequence 1 operational procedure seems to be best suited as a pontoon causeway installation technique.

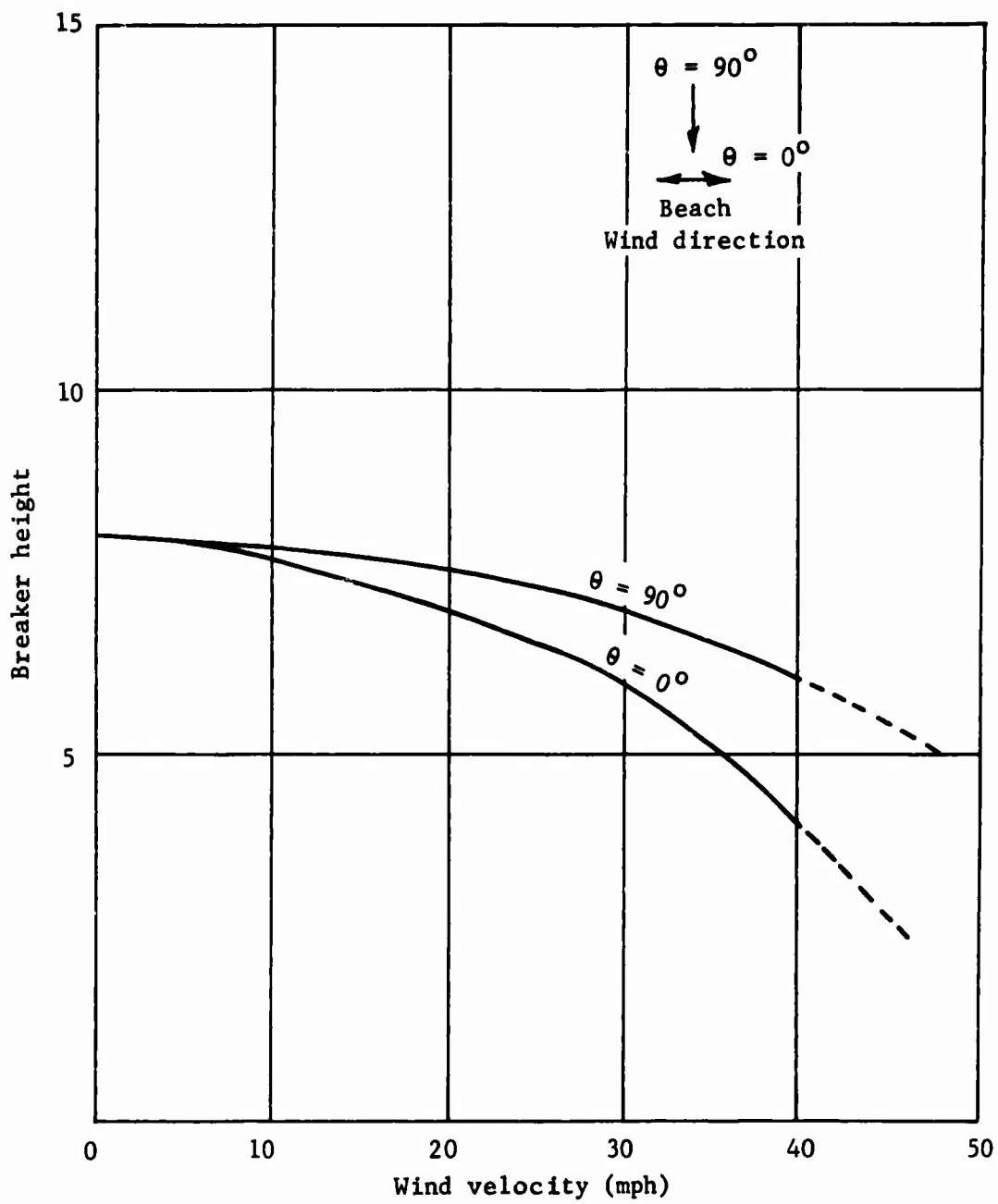

Figure 10. Estimated limits for installation of an elevated causeway through the surf zone.

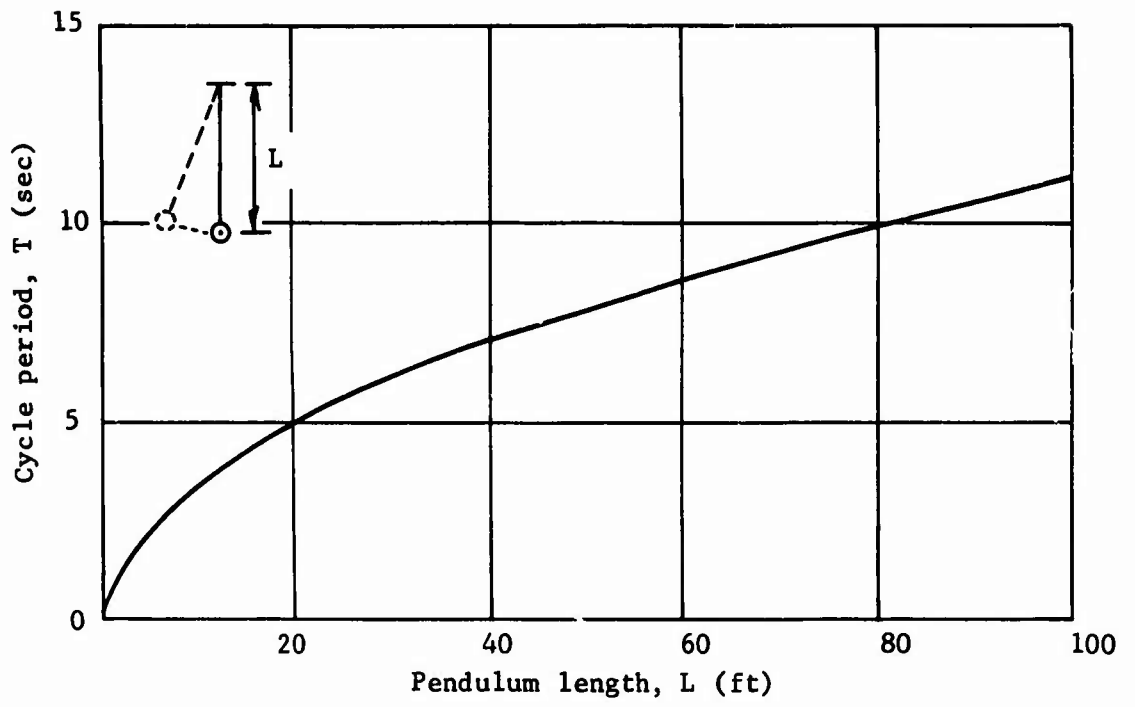

Figure 11. Cycle period of pendulum as a function of length.

The installation tests demonstrated a technique for handling piles of limited length. The technique is to place the piles in the spudwell and weld stop plates to the pile so that the pile may be transported in an upright position. This technique is limited to piles no longer than 50-60 feet because pontoon motions will toss longer piles back and forth in the spudwell. The tests on 9 December experienced this problem to a limited degree with piles only 47 feet long.

An analysis of the pile size to survive extreme wave loads indicated that piles 3 feet or greater in diameter may be required.⁶ Also, pile lengths greater than 100 feet will be required in water depths of 50 feet or more. These piles may weigh more than 200 pounds per foot of length. The techniques used in the tests are not feasible for such large piles, for which, alternative pile handling methods must be considered. Three methods are suggested: (1) provide a crane and special equipment capable of handling the piles, (2) provide (or develop) a pile splicing technique that can be applied in a short time so that shorter pile lengths can be used and, (3) develop a device to stabilize the long piles in the pontoon spudwell. These problems are addressed in a subsequent report.⁶

Vertical orientation of the piles for driving is a critical problem in all water depths. If the piles are not driven vertically, the pontoon will bind on the skewed piles or the pile is forced to deflect, creating an undesirable prestress in the pile as the pontoon is elevated. This was not a problem in current tests because the pontoon was elevated only a few feet.

Consider the effect of pontoon heave, surge and pitch on vertical pile orientation. Heave motions are purely vertical and do not create a problem. To observe the effects of surge and pitch, consider a spudwell several inches larger than the pile, which permits the pile to rotate through an angle, θ , inside the spudwell. Figure 12 shows the effect of horizontal pontoon movement (surge) on a pile resting on the bottom in shallow water and in deep water. Small movements in shallow water cause the pile to tilt up to the maximum possible angle; however, in deep water movements must be much greater to tilt the pile. Figure 13 reflects the critical placement of the pile on the bottom and its effect upon vertical orientation of the pile. To demonstrate the effects of pontoon pitch on vertical pile orientation, consider a pile which fits snugly in the spudwell. Three things can happen: (1) the pile can rotate with the pontoon, (2) the pontoon can be restrained from pitching, or (3) the pile can fail at the spudwell. Figure 14 shows how the pile is likely to react in shallow and in deep water. It is intuitively apparent that neither of the above circumstances lends itself to precise vertical pile orientation; therefore, by elimination, the pile-spudwell geometry should allow the pile to rotate in the spudwell. The problem then reverts to finding a method of attaining vertical pile orientation within an oversized spudwell.

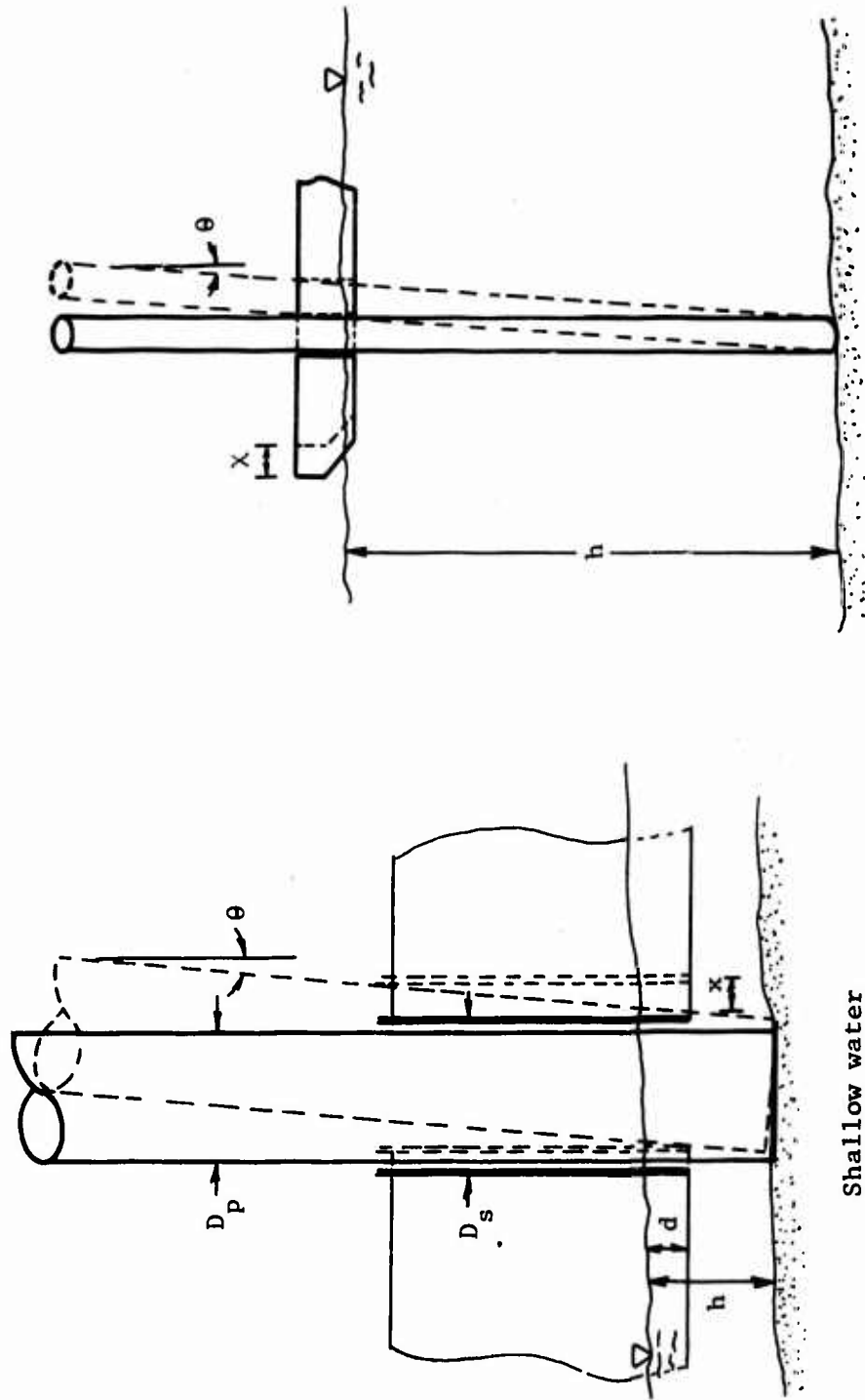

Deeper water

Shallow water

Figure 12. Effect of pontoon translation on vertical orientation of piles.

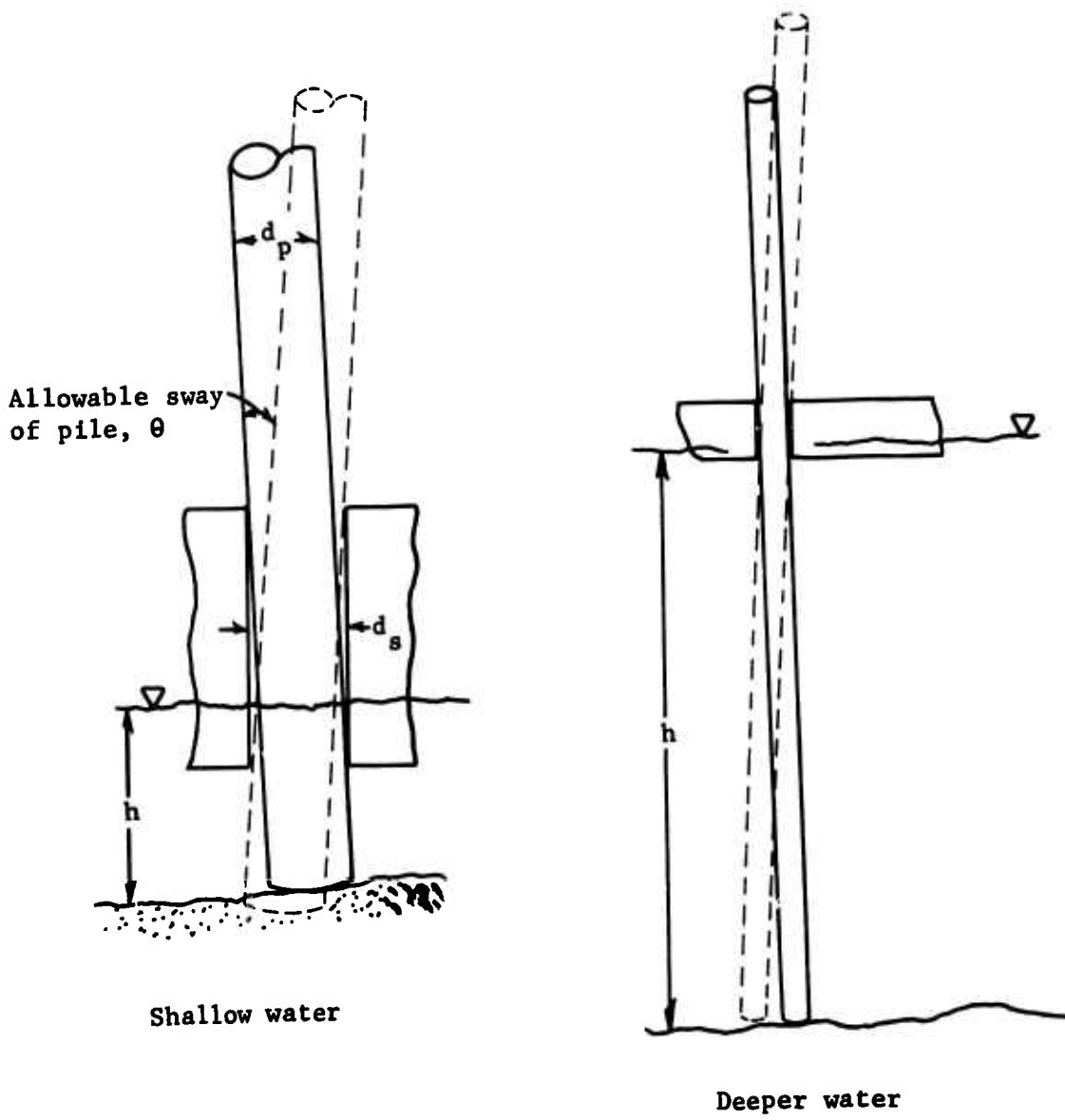

Figure 13. Effect of bottom position of pile on vertical orientation.

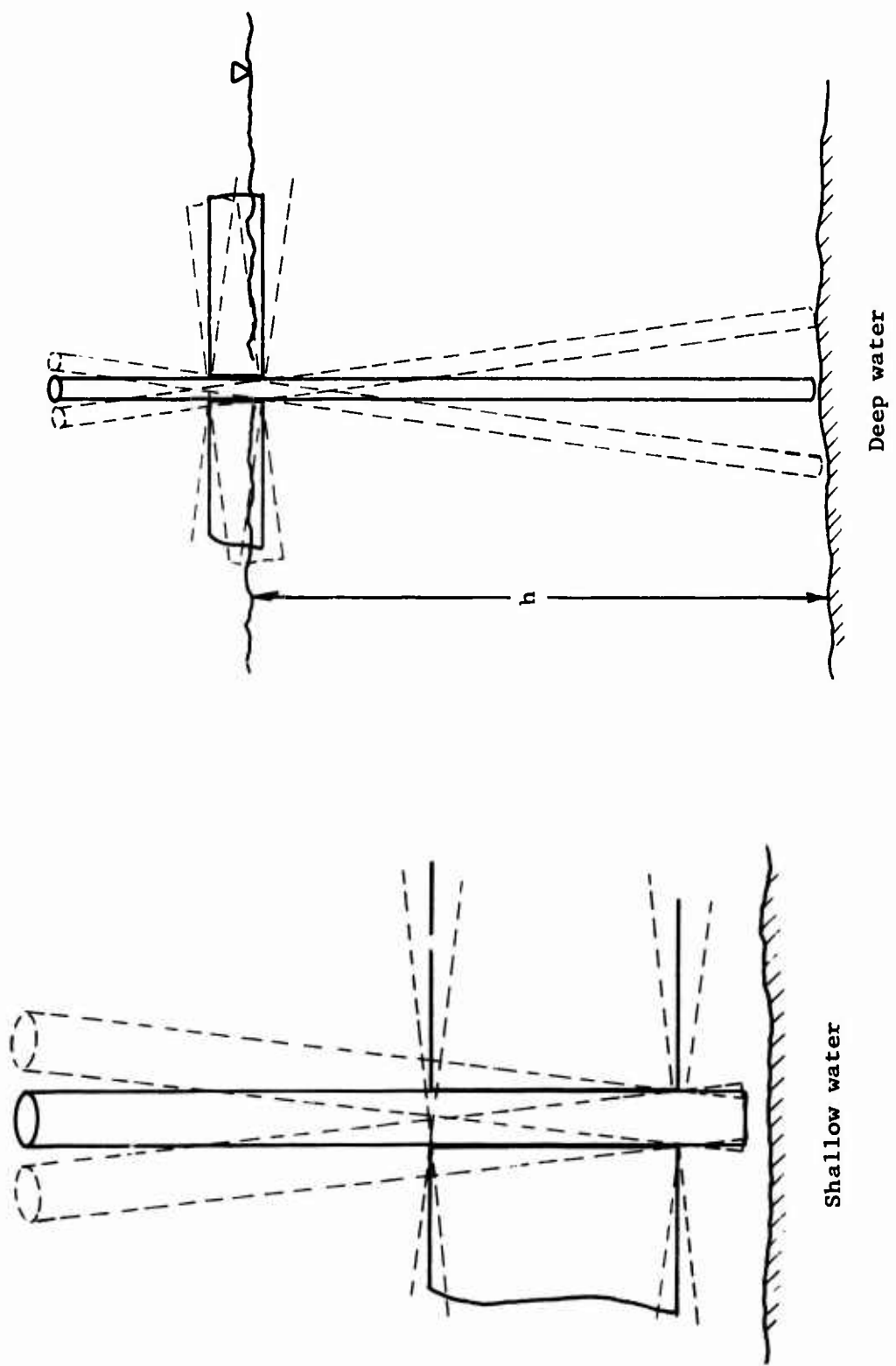

Figure 14. Effect of pontoon pitch on piles and spudwells.

During the offshore tests, one of the driven piles failed while it restrained the floating pontoon, as shown in Figure 9. The pile that failed was the first one driven. The failure probably occurred before the other three piles were driven because it was the primary restraint for the pontoon being pitched about in the wind and waves. The failure occurred at the bottom of the spudwell, most likely following local impact from the edge of the spudwell. The real significance of the failure is that it emphasizes the possibility of pile failure during the causeway installation.

During the near shore test, the operational procedure included disconnection and marriage of the two pontoons in the surf in order to remove the 50-ton crane from the pontoon being elevated. This procedure would be a significant part of the sequence 3 installation technique, indicating a basic weakness in it. Each of the other sequences (except 1a) require that a pontoon lighter be married to the offshore end of the causeway to remove the crane. Conditions should be considerably less severe at the offshore end than in the surf, and the operation would be performed only once.

Estimates derived from the test data can be extrapolated to simulate the installation of a causeway on an open beach. Table 2 estimates time, men, and equipment required to install a 3,000-foot causeway using 1 or 2 work crews. Figure 15 shows the results of a simulated installation of a 3,000-foot causeway using first one, then two work crews using sequence 1b technique. The simulation estimates 77 and 45 hours, respectively, to install a 3,000 foot elevated causeway with one and two work crews (no shore crew). A further derivation of the time-man-power-equipment data is compiled in the plot of Figure 16. Here, the time required to install an elevated causeway is estimated as a function of the causeway length for one work crew and for two work crews. Two alternatives are included. The alternatives provide an additional shore crew to construct the causeway beach interface while the elevation operations are in progress. The plot indicates that it becomes more efficient (timewise) to provide the shore crew as the causeway becomes shorter than 2,700 feet.

FINDINGS AND OBSERVATIONS

1. A 50-short ton (weight) truck crane was able to operate on the deck of a 28x90x5 foot Ammi pontoon with no stability problems. The crane was moved across two adjacent end connected pontoons. Motion response of the pontoon to the waves did not severely restrict the crane operations. Handling lines were used to control the swinging of objects picked up by the crane. A calm and experienced operator was a definite asset to the operations.

2. To assist beaching and mooring the end-to-end connected causeway, tracked vehicles were required on the beach for maneuverability.

Table 2. Time, manpower, equipment required to install an elevated pontoon causeway

Elevated Pontoon Causeway Installation (3,000 feet)		
<u>EQUIPMENT</u>	<u>1 Crew</u>	<u>2 Crews</u>
Pontoons (90 ft)	34	34
Warping Tugs	4	4
Anchors	50	50
Medium-Sized Crane	1	2
Small Crane	1	2
Fork Lift	1	2
Pile Hammer (16,000 ft-lb)	1	2
Elevating Units & Power Source	System	2 Systems
Pile Caps, Chains, etc.	136	136
Welding Machines	8	12
Miscellaneous Rigging Gear		
 <u>MANPOWER</u>		
Warping Tug Crews	24	24
Crane Operator and Rigger	2	4
Riggers and Helpers	12	24
Pile Hammer Operators	2	4
Welders	12	18
Elevating Unit Operators	2	4
 <u>TIME REQUIREMENTS FOR VARIOUS SUBTASKS</u>		
Floating Pontoon Causeway Assembly	2 hours	
Causeway Beaching	1 hour	
Moor Causeway	2 hours	
Emplace Piles in Spudwells	1/2 hour/pontoon	
Drive Piles to 20+ feet Penetration	1 hour/pontoon	
Rig Pontoons to be Elevated	1/2 hour/pontoon	
Elevate Pontoons	1/2 hour/pontoon	
Temporarily Suspend Pontoons	1/2 hour/pontoon	
Weld Pile-Pontoon Connection	3 hours	
Install Causeway-Shore Ramp	16 hours	

ONE WORK CREW

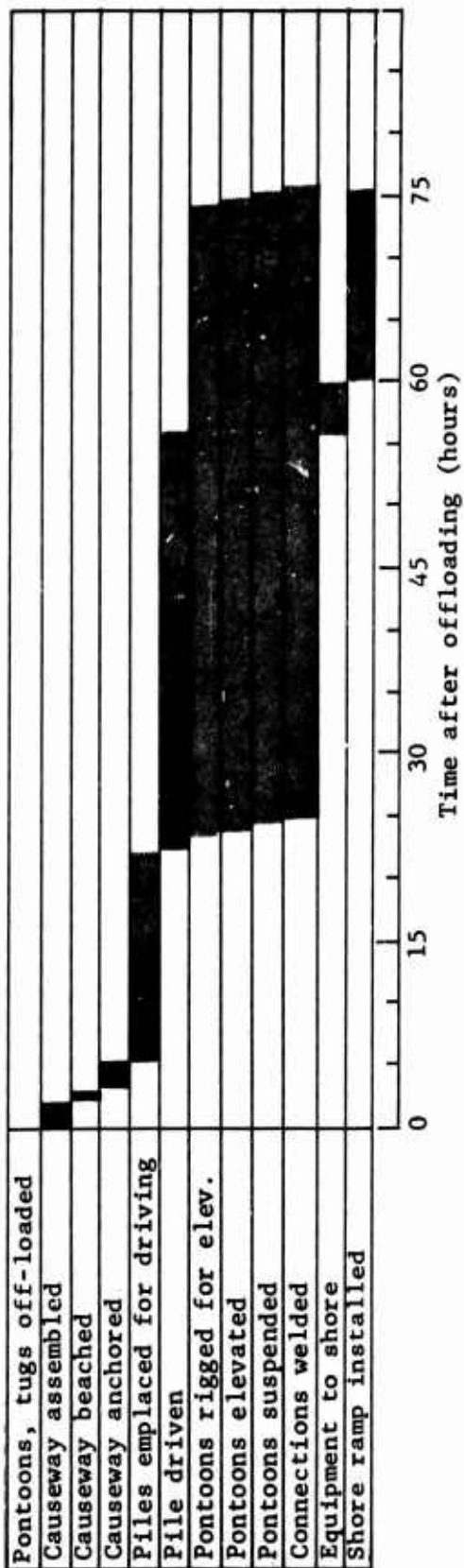

TWO WORK CREWS

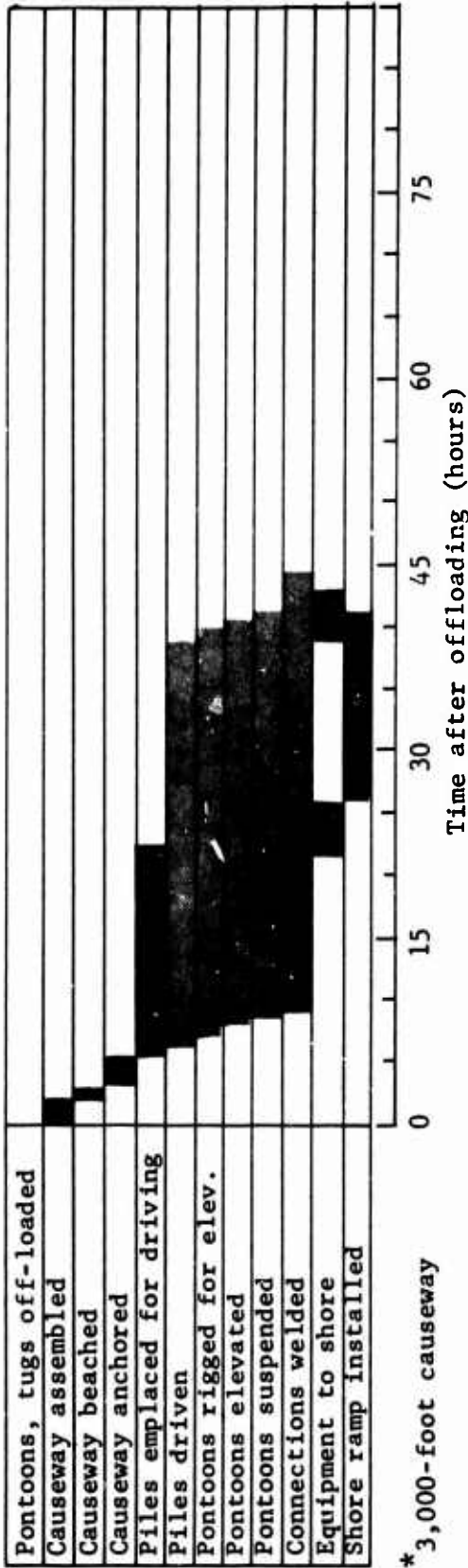

* 3,000-foot causeway

Figure 15. Simulated installation of a 3,000-foot elevated causeway for 1 and 2 work crews and installation sequence lb.

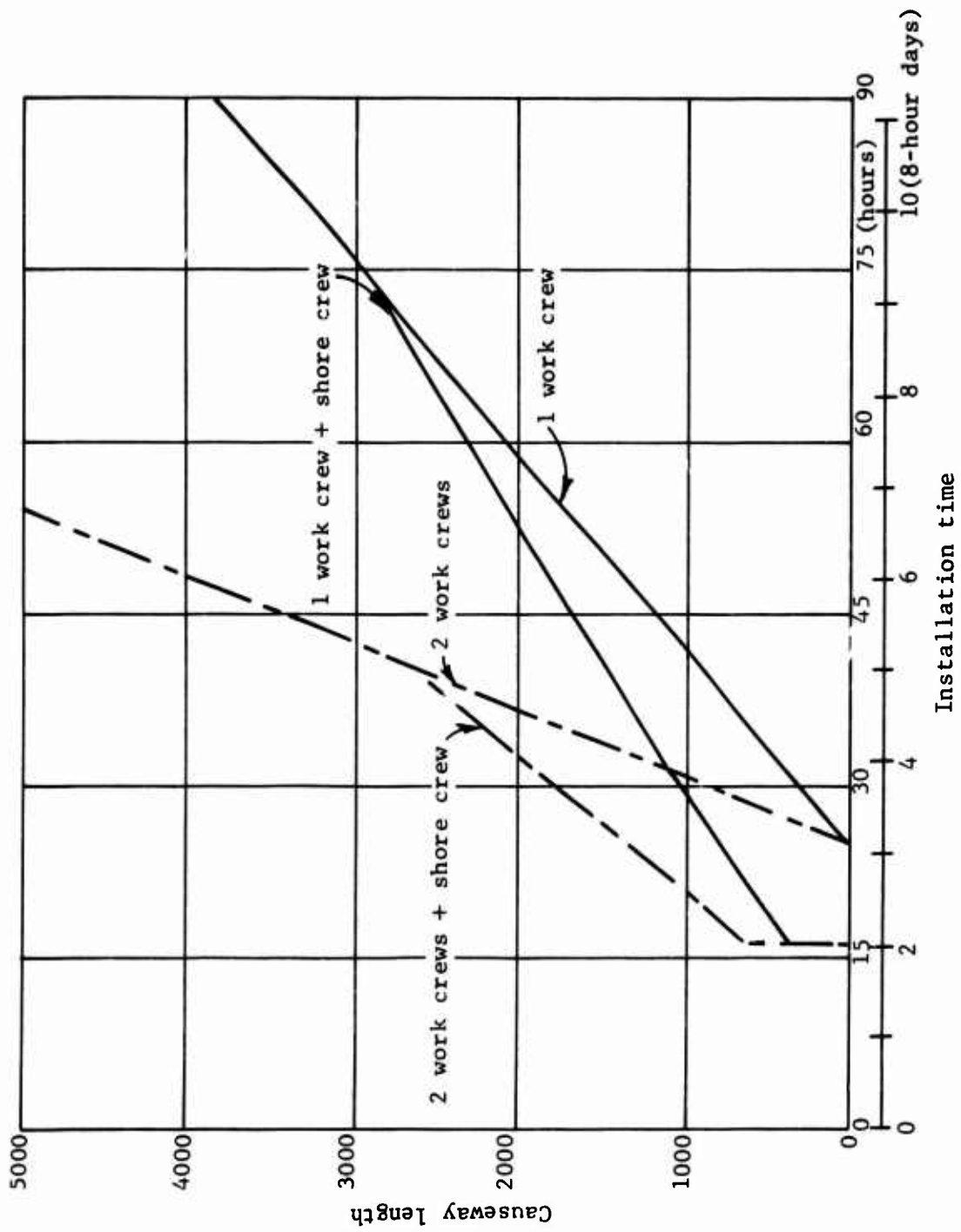

Figure 16. Comparison of installation time for 1 and 2 work crews using installation sequence lb.

3. Surf 5-7 feet high was encountered during part of the tests; it is estimated that a full length causeway could negotiate surf up to 8 feet, but with some degraded effectiveness. High winds lessen the effectiveness of all operations.

4. Pile handling and driving operations were best conducted with a crane on the deck of the pontoon causeway. The crane was able to handle and drive all corner piles from a central location. Precise vertical alignment of the piles in the spudwells was difficult to attain in the surf and swells, with no stationary reference point available.

5. Increasing the clearance between the piles and the pontoon spudwells decreases the likelihood of local damage to piles or spudwells while the piles are placed and driven in the surf.

6. One pontoon was lifted above the surf with block and tackle gear, using two dozers as the power source. No exceptional line entanglement was experienced due to the pontoon motion.

7. Two pontoons were disconnected and connected in the surf. This operation was difficult and potentially hazardous to personnel.

8. Estimates of the installation operation indicate that two work crews can install a 3,000-foot causeway about 40 percent faster than a single crew. A supplementary shore crew becomes advantageous for causeway lengths less than 2,000 feet.

CONCLUSIONS

1. Crane operations required for handling and driving piles can be successfully conducted from the deck of the 28-foot wide Ammi pontoon causeway. The crane can move to adjacent pontoons under its own power.

2. An elevated pontoon causeway can be installed in surf conditions up to 8 feet. The causeway can be installed in water up to 20 feet deep; however, wave loads on the piles and pontoons in water depths greater than 15 feet are expected to tax the structural strength of the pontoon and piles as now configured.

3. Installation technique sequence 1b is the preferred method, since it minimizes the operational time in the surf.

4. The pontoon can be lifted on piles with a block and tackle lift system; however a power source (winch) with positive control should be used and should be mounted on the pontoon being lifted. Positive control in the power source improves the safety aspect of the system.

REFERENCES

1. "Interim Report on Ammi Pontoon Elevation Tests" NCEL Letter Report of 11 July 1969 by B. R. Karrh.
2. "Joint Surf Manual," U. S. Pacific Fleet and U. S. Atlantic Fleet, May 1967.
3. Department of the Army, Transportation Corps, "Artificial Breakwaters - Phase IV - The Behavior of Ships and Lighters Under Various Wave Conditions during Shiplside and Surf Cargo Operations," by Rocco Famma, November 1956, Transportation Research and Engineering Command, Fort Eustis, Virginia.
4. NCEL Technical Note N-1052, "Hydrodynamic Response of Ammi Causeway in Surf Zones," by J. A. Drelicharz, Port Hueneme, California, January 1970.
5. NCEL Technical Note N-1187, "Motion of Freely Suspended Loads Due to Horizontal Ship Motion in Random Head Seas," by H. S. Zwibel, Port Hueneme, California.
6. NCEL Technical Note N-_____, "Development Study of an Elevated Causeway," by B. R. Karrh, Port Hueneme, California (In preparation).