

DISCLAIMER NOTICE

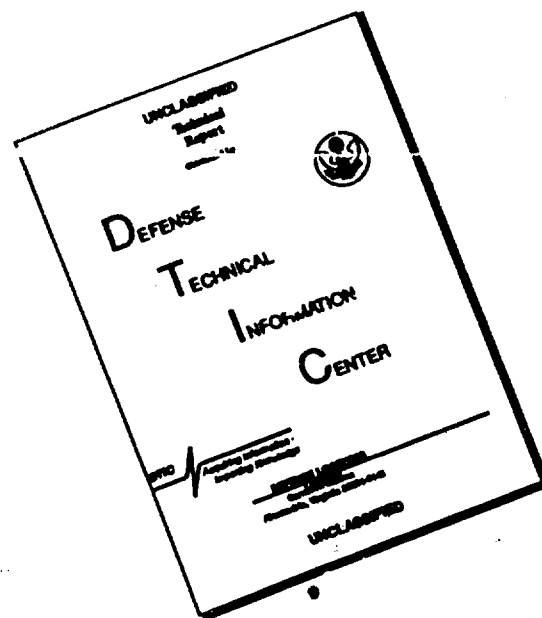

THIS DOCUMENT IS BEST QUALITY AVAILABLE. THE COPY FURNISHED TO DTIC CONTAINED A SIGNIFICANT NUMBER OF PAGES WHICH DO NOT REPRODUCE LEGIBLY.

AD737338

ARL-TR-72-6
17 January 1972

FINAL REPORT UNDER CONTRACT N00014-70-A-0166-0005
15 April 1971 - 15 January 1972

This research sponsored by the

Office of Naval Research
Contract N00014-70-A-0166-0005
NR 291-050

APPROVED FOR PUBLIC
RELEASE, DISTRIBUTION
UNLIMITED.

APPLIED RESEARCH LABORATORIES
THE UNIVERSITY OF TEXAS AT AUSTIN
AUSTIN, TEXAS 78712

UNCLASSIFIED

Security Classification

DOCUMENT CONTROL DATA - R & D

Security classification of title, body of abstract and indexing annotation must be entered when the overall report is classified

1. ORIGINATING ACTIVITY (Corporate author) Applied Research Laboratories The University of Texas at Austin Austin, Texas 78712		2a. REPORT SECURITY CLASSIFICATION UNCLASSIFIED	
		2b. GROUP ---	
3. REPORT TITLE FINAL REPORT UNDER CONTRACT NO0014-70-A-0166-0005			
4. DESCRIPTIVE NOTES (Type of report and inclusive dates) final report, 15 April 1971 - 15 January 1972			
5. AUTHOR(S) (First name, middle initial, last name) ---			
6. REPORT DATE 17 January 1972		7a. TOTAL NO. OF PAGES 29	7b. NO. OF REFS ---
8a. CONTRACT OR GRANT NO. NO0014-70-A-0166-0005		8b. ORIGINATOR'S REPORT NUMBER(S) ARL-TR-72-6	
b. PROJECT NO. NR 291-050		8c. OTHER REPORT NO(S) (Any other numbers that may be assigned this report) ---	
c.			
d.			
10. DISTRIBUTION STATEMENT Approved for public release; distribution unlimited.			
11. SUPPLEMENTARY NOTES ---		12. SPONSORING MILITARY ACTIVITY Office of Naval Research Department of the Navy Arlington, Virginia 22217	
13. ABSTRACT During the period 15 April 1971 to 15 January 1972, work on this project has included both the modification of the equipment and the taking of data with the equipment in its various stages of modification. Modifications include the replacement of laboratory type equipment with less bulky printed circuits and the manufacture of new cutting heads to fit existing coring tools. Data were taken on three field trips, two of which were to the Gulf of Mexico aboard A&M research vessels "ORCA" and "ALAMINOS" and one to Baffin Bay, Texas, on a University of Texas research barge. The data uphold the feasibility of <i>in situ</i> measurements of acoustic velocity while coring. (S)			

UNCLASSIFIED

Security Classification

UNCLASSIFIED

Security Classification

14 KEY WORDS	LINK A		LINK B		LINK C	
	ROLE	WT	ROLE	WT	ROLE	WT
Acoustic velocity corer <i>in situ</i>						

DD FORM 1473 (BACK)
1 NOV 68
(PAGE 2)

UNCLASSIFIED

Security Classification

ABSTRACT

(U) During the period 15 April 1971 to 15 January 1972, work on this project has included both the modification of the equipment and the taking of data with the equipment in its various stages of modification. Modifications include the replacement of laboratory type equipment with less bulky printed circuits and the manufacture of new cutting heads to fit existing coring tools. Data were taken on three field trips, two of which were to the Gulf of Mexico aboard A&M research vessels "ORCA" and "ALAMINOS" and one to Baffin Bay, Texas, on a University of Texas research barge. The data uphold the feasibility of *in situ* measurements of acoustic velocity while coring.

The status report for 1 January - 30 June 1971 described the construction and preliminary testing of an acoustic velocimeter to be used during sediment coring. During the current reporting period, several modifications have been made to the equipment and tests have been made, both in the lab and in the field.

Previously, the output from the velocimeter was a negative going triangular pulse whose height was proportional to the acoustic velocity of the sediment. This output was displayed on an oscilloscope and a photograph taken of the oscilloscope screen to record the profile of the acoustic velocity as the coring head penetrated the sediment layers. Under controlled conditions the scope can be triggered at the proper time, but under field conditions this usually isn't easily done. A method was needed to permanently record the profile, such as recording the voltage level on magnetic tape or directly on an oscillograph or paper recorder. The triangular pulses do not record well on magnetic tape or other recorders, so the electronic circuit was modified by adding two sample and hold amplifiers to the output in order to sample the level that the triangular pulse reached and then hold this level until the next pulse. This provides a slowly varying voltage level proportional to the sampled acoustic velocity. This type of output is easily recorded on an FM magnetic tape recorder at slow speed (i.e., 3.75 ips), or an oscillograph.

Another modification to the electronics was to build in an electronic delay so that, instead of triggering the time delay to voltage converter with the transmit pulse, it could be triggered a preset time after the transmit pulse and thereby eliminate interference by electrical feedover of the transmit pulse into the receive circuitry. When the equipment was first used with a long connecting cable, it was

found that the electrical feedover of the transmit pulse was causing the time delay to voltage converter to trigger before the arrival of a received signal, thus giving an erroneous reading.

The cutting head of the corer has also been modified to be more versatile. Instead of imbedding the transducer elements directly into the cutting head as previously, a separate holder for each transducer has been built that can be attached to the cutting head by screws. Thus, each of the transducers is individually replaceable and can be transferred from one cutting head to another in case of injury to any of the parts. In addition, the transducer can be added to a conventional cutting head by drilling and tapping. Figure 1 shows this modification.

Other modifications to the equipment include replacement of laboratory type equipment such as the projector power amplifier, oscillator, pulse timing generator, signal gates, and bandpass filters with laboratory built circuits using printed circuits and both discrete and integrated circuit techniques. All the associated circuitry can now be contained in a single fiberglass case.

Figure 2 shows a block diagram of the electronic system. The transmit section generates an acoustic pulse for transmission across a sediment sample and the receiver section receives the acoustic pulse, amplifies and filters it, and measures the elapsed time between transmission and reception. Figures 3 through 6 show schematics of the transmit sections. A 190 kHz continuous sine wave is generated by the oscillator which is a Wien bridge oscillator using an IC operational amplifier. This type circuit provides a high purity sine wave that is stable both in frequency and amplitude. The output of the oscillator is buffered by an emitter follower. The output of the emitter follower is applied both to the signal gating circuit and to a zero crossing detector. The output of the zero crossing detector is a square pulse

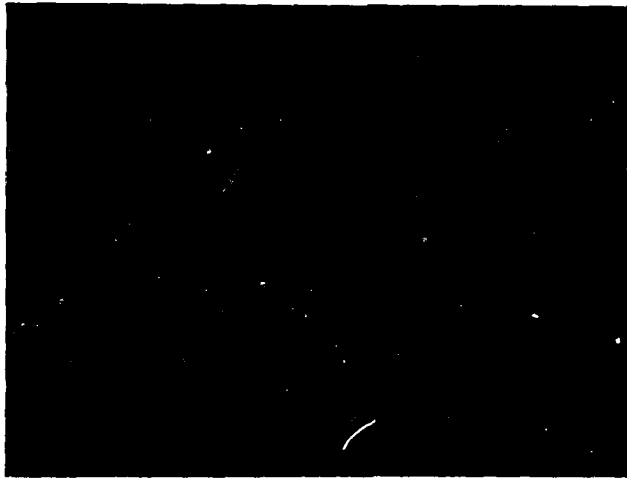
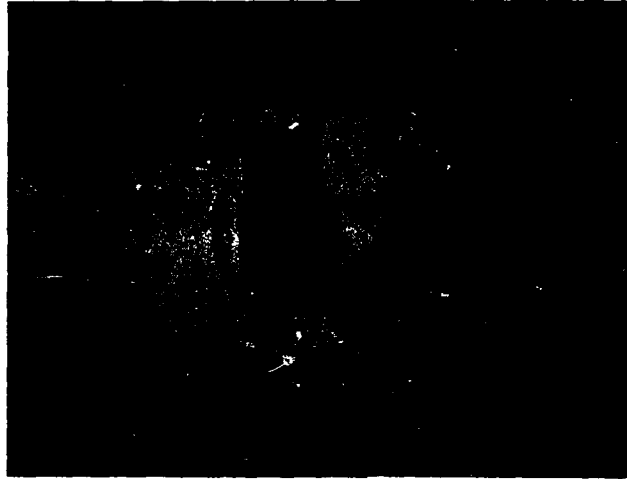

FIGURE 1
CUTTING HEAD WITH TRANSDUCER MODIFICATIONS

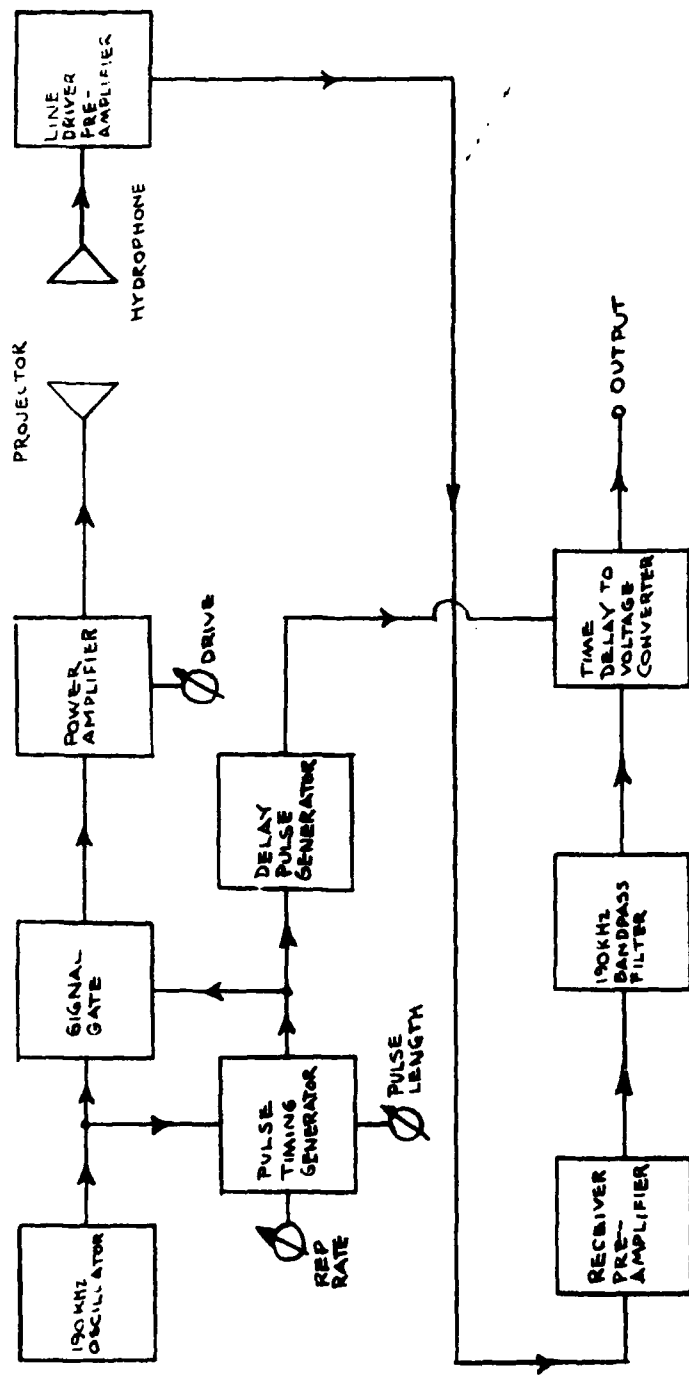

FIGURE 2
SYSTEM BLOCK DIAGRAM

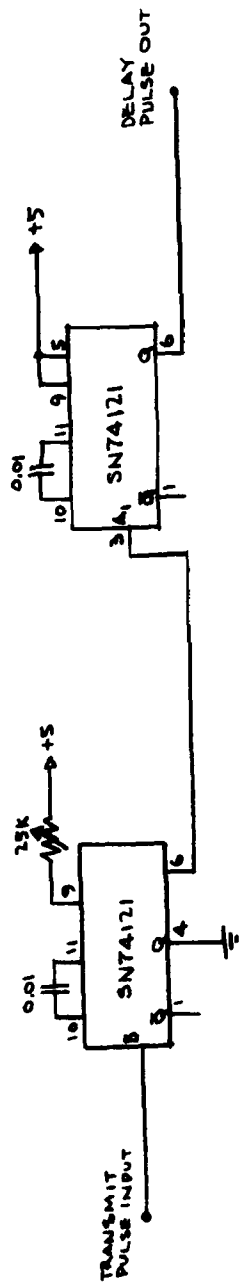

FIGURE 5
DELAY PULSE GENERATOR SCHEMATIC

ARL - UT
AS-72-7
DJS - DR
1 - 17 - 72

each time the oscillator sine wave crosses the zero axis in a positive direction. The output of the zero crossing detector is applied to the pulse timing generator circuit so that the positive output pulse of the generator starts at a positive going zero crossing of the signal and ends also at a positive going zero crossing. Both the sine wave signal and the positive pulse are applied to the transmit signal gate, which acts as an electronic switch. The output of the signal gate is thus a gated coherent sine wave whose length and repetition rate are controlled by the pulse timing generator. The output of the signal gate is applied to a complimentary symmetry power amplifier circuit capable of about 15 W output into an 8 Ω load. This in turn drives the piezoelectric element of the projector to provide a short burst of acoustic energy.

The acoustic energy which is transmitted across the sediment sample is received by another piezoelectric element identical to the projector. This element converts the acoustic pulse to an electrical pulse. A line driver preamplifier located near the receiving element converts the high impedance of the element to a low impedance to drive the long coaxial cable to the receive electronics. This preamplifier also amplifies the signal about 6 dB. Power for the preamplifier is supplied by the coaxial cable which carries the signal. At the surface, the receive signal is applied to the input of a grounded base amplifier, which transforms the impedance back up and further amplifies the signal. The output of this stage is then applied to the input of an operational amplifier bandpass filter which has a center frequency of 190 kHz, Q of about 5, and rolloff of about 12 dB per octave. This stage has a gain of 20 dB and the received signal is usually large enough to saturate this stage if the acoustic attenuation in the sediment is low. The schematic of these three receiver stages is shown in Fig. 7. After amplifying and filtering, the received signal pulse is then applied to the time delay to voltage converter.

Figures 8, 9, and 10 show details and waveforms for the time delay to voltage converter. The signal pulse from the bandpass filter is applied to a schmitt trigger circuit to change the analog signal to a series of digital pulses. The threshold of the schmitt trigger is set such that low amplitude noise does not trigger the circuit. The output from the schmitt trigger and the delay pulse output are used to set and reset an R-S flip-flop. The output of this flip-flop is a positive pulse which starts at a time following the transmit pulse set by the receiver delay control. The pulse stops when a pulse is received. This positive pulse is used to switch an integrator circuit such that when the pulse is positive the integrator circuit integrates a constant voltage so that its output is a negative triangular pulse the same length as the positive pulse. As the time delay of the received pulse changes, the voltage reached by the integrator circuit also changes, thus providing a voltage output proportional to the time delay of the received pulse. The integrator is followed by two sample and hold circuits. The first sample and hold is switched on by the positive pulse from the R-S flip-flop; thus it samples the triangular pulse and holds at the voltage level that the pulse reaches. The second sample and hold is switched on by a 0.2 msec pulse from a monostable multi-vibrator which is triggered by the trailing edge of the R-S flip-flop pulse. The second sample and hold samples the output of the first sample and hold after the first has started holding the proper voltage. Thus, the output of the second sample and hold is a constant level which changes only if the time delay of the received pulse changes. The output of the entire system is consequently a voltage level dependent upon the acoustic velocity of the material between the two transducers.

Data were obtained using the equipment in its various stages of modification during three field trips this reporting period. The first

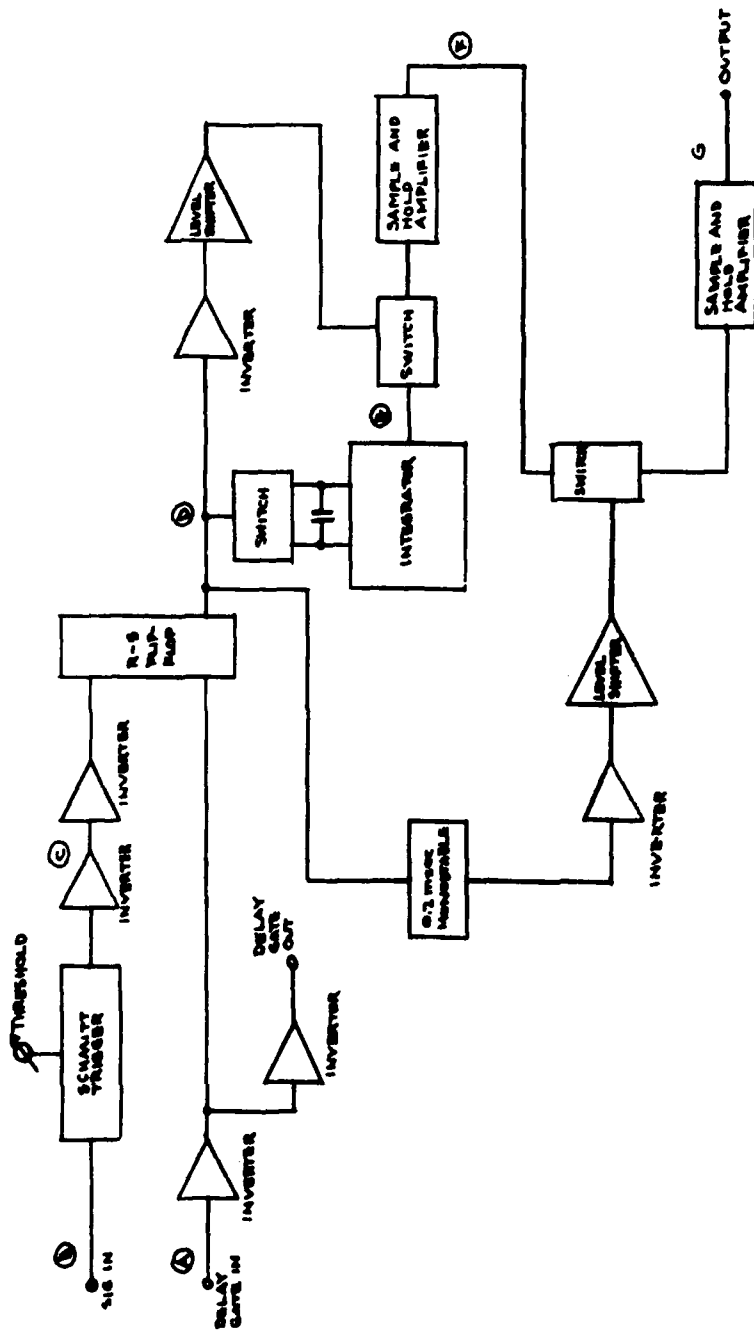

FIGURE 9
TIME DELAY TO VOLTAGE CONVERTER BLOCK DIAGRAM

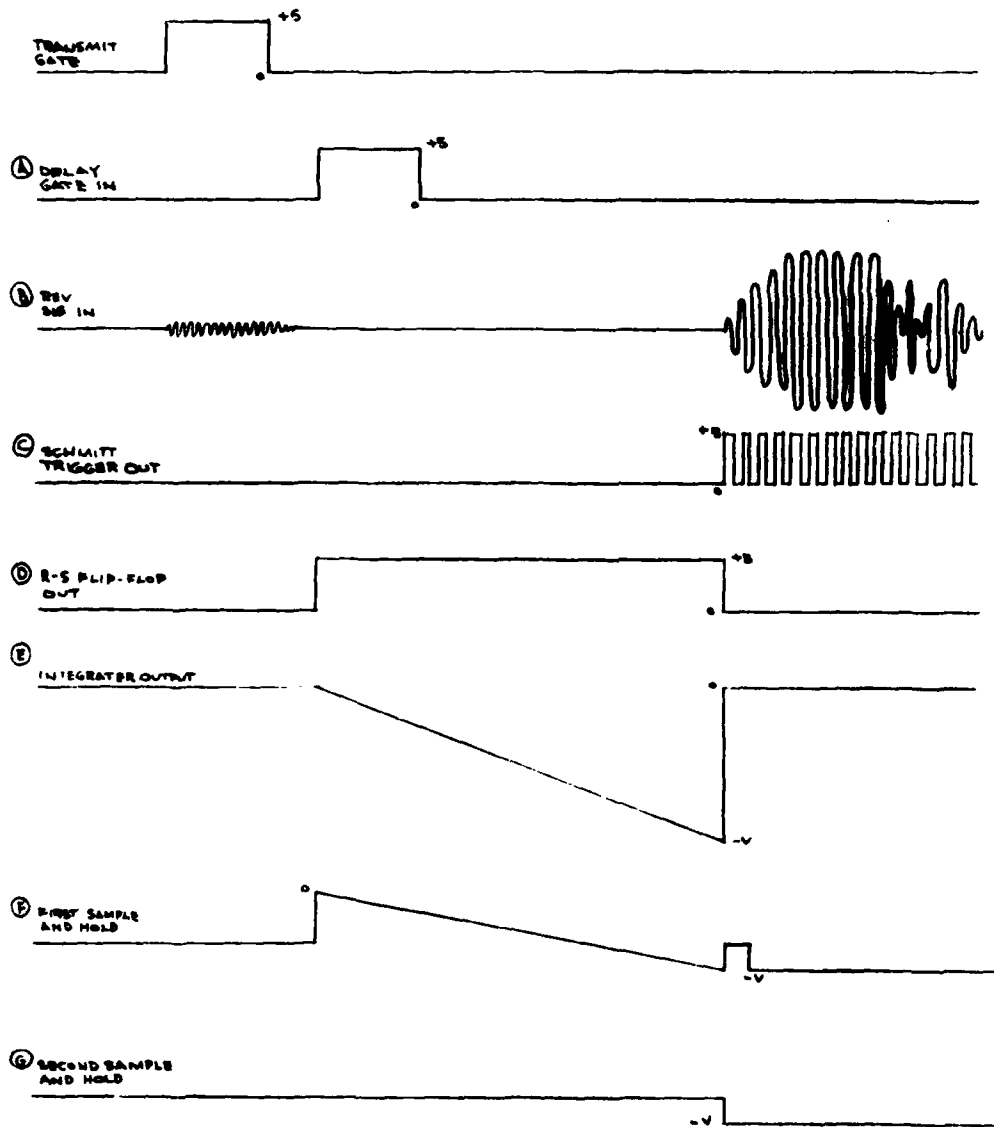

FIGURE 10
TIME DELAY TO VOLTAGE CONVERTER TIMING DIAGRAM

ARL - UT
AS-72-12
DJS - DR
1 - 17 - 72

of these trips was aboard the Texas A&M research vessel "ORCA" off the coast of Galveston Island in the Gulf of Mexico in August 1971. On this cruise, the equipment was to be used on an unlined gravity corer approximately 10 ft in length and 2 7/8 in. i.d. A cutting head of the proper dimensions was constructed at the laboratory and, in this case, the transducers were encapsulated directly into the cutting head. The two 15 ft coaxial cables from the transducers were terminated in a single 4-pin waterproof connector which mated the two coaxial cables to a 150 ft length of Belden 8425 5-conductor shielded cable. This type cable was the only kind immediately available at the lab. This cable was not exactly suitable for the purpose, since the leads to the projector were not shielded from the leads to the hydrophone; consequently, the projector had to be operated with a smaller drive voltage than usual and the receiver gain increased proportionately to maintain adequate signal level into the time delay to voltage converter. This arrangement seemed to work adequately in the lab, but in the field when the gravity corer was dropped into the bottom, the higher noise level which was encountered obscured the signal from the projector and thus prevented any useful measurement of the acoustic velocity of the bottom sediments. Although this trip was a failure as far as data collection, we were made aware of the stringent requirements on the connecting cable--a valuable realization, since the next projected field trip was the deeper water in the Gulf of Mexico, requiring a cable 500 to 600 ft long.

The second field trip during this period was conducted aboard the Texas A&M research vessel "ALAMINOS" during its cruise 71A13, leg 2, from 6 November through 10 November 1971.

For this operation the equipment was to be used on a lined piston corer approximately 40 ft in length with inside diameter of the plastic liner of 2 3/4 in. A new cutting head was constructed for this

new inside dimension with essentially the same configuration as the previous cutting head except that the transducers were mounted into separate holders that were attached to the cutting head by screws. A 40 ft coaxial cable led from each transducer to a junction box and attached to it by waterproof coaxial connectors. The junction box could be attached to the top of the core pipe with clamps which held it rigid on the pipe. Inside the junction box was a line driver preamplifier for the hydrophone and a piezoelectric accelerometer (Columbia Model 904). The cable to the surface was connected through a stuffing gland to provide a watertight seal. Since proper cable was not readily available (i.e., two coaxial conductors to provide proper isolation between transmit and receive signals plus one coaxial conductor for the accelerometer), a cable was constructed in the laboratory from three 600 ft lengths of 1/8 in. diam teflon coaxial cable available on surplus, the three cables being wrapped by hand with vinyl tape to form a single cable. Each conductor pair had 55 pF of capacitance per foot.

Three cores were taken with the equipment. The first two cores were taken just off the Mississippi delta in about 30 fathoms of water. The bottom was very soft and fairly homogeneous and the corer penetrated about 35 ft. Sand, silt, clay, and water content measured by Texas A&M are shown in Table I for these two cores. Figure 11 shows the acoustic velocity profile for these cores, Drop No. 1 and Drop No. 2; the top trace is the accelerometer output and the bottom trace is the velocity profile, and the water-sediment interface occurs on the right side of the trace. In the first core, the only significant change is a decrease in acoustic velocity of about 20 m/sec between the water above the bottom and the sediments. In the second core, the acoustic velocity again shows a 20 m/sec decrease in the sediments with further changes of the same order further down in the bottom. The time required for penetration of the first core is slightly less than 1 sec. For the

TABLE I

CORE 1

CORE 2

DEPTH (cm)	% SAND	% SILT	% CLAY	MEDIAN DIAMETER	WATER CONTENT (% dry wt)
10	0.39	31.61	68.00	9.8	86.78
20	0.10	25.76	74.14	9.6	102.54
30	0.03	28.97	71.00	10.0	73.81
40	0.32	33.24	66.44	9.6	90.13
50	0.07	20.60	79.33	10.2	82.14
70	0.05	31.73	68.22	9.7	73.16
90	0.05	28.68	71.27	9.9	76.16
100	0.05	33.09	66.86	9.5	64.53
125	0.03	29.37	70.60	10.0	71.67
140	0.04	27.11	72.85	10.0	78.90
160	0.11	33.44	66.45	9.7	83.78
180	0.18	28.86	70.96	9.9	68.85
200	0.07	30.01	69.92	9.9	72.96
220	0.06	31.26	68.68	9.8	70.99
230	0.05	29.10	70.85	9.8	70.72
240	0.02	30.19	69.79	9.7	66.99
255	0.04	31.74	68.22	9.6	71.69
275	0.72	44.72	54.56	9.0	77.06
300	1.92	25.97	72.11	10.0	93.56
320	0.07	21.23	78.70	10.3	99.91
340	0.05	25.64	74.31	10.0	88.36

DEPTH (cm)	% SAND	% SILT	% CLAY	MEDIAN DIAMETER	WATER CONTENT (% dry wt)
20	2.57	41.12	56.31	8.8	110.11
40	1.65	45.59	52.76	8.4	93.87
60	7.71	48.81	43.48	7.2	68.94
80	1.08	50.52	48.40	7.8	69.72
100	1.96	41.40	56.64	9.0	80.09
120	0.09	34.37	65.54	9.6	87.06
140	3.21	47.73	49.06	8.0	68.79
160	1.24	41.15	57.61	9.0	89.51
180	1.28	37.67	61.05	9.2	84.44
200	2.22	52.17	45.61	7.6	66.10
220	0.25	43.90	55.85	8.9	74.55
240	2.88	37.33	59.79	9.1	70.47
260	2.02	44.60	53.38	8.7	64.99
280	2.02	41.36	56.62	8.8	69.33
300	0.30	34.47	65.23	9.4	83.59
320	0.13	32.86	67.01	9.7	80.37
340	1.09	42.85	56.06	8.7	68.30
360	0.25	20.88	78.87	10.8	91.05
380	2.56	42.63	54.81	8.6	62.46
400	0.63	39.47	59.90	9.2	68.34
420	0.88	45.93	53.19	8.4	59.68
440	1.59	44.96	53.45	8.5	57.83
460	2.68	43.37	53.95	8.5	61.92
480	0.99	38.80	60.21	9.3	65.95
500	5.49	41.19	53.32	8.5	59.33
520	0.69	44.32	54.99	8.6	54.68
540	0.38	34.97	64.65	9.6	67.48
560	3.33	42.15	54.52	8.6	63.16
580	2.72	68.01	29.27	6.5	66.40

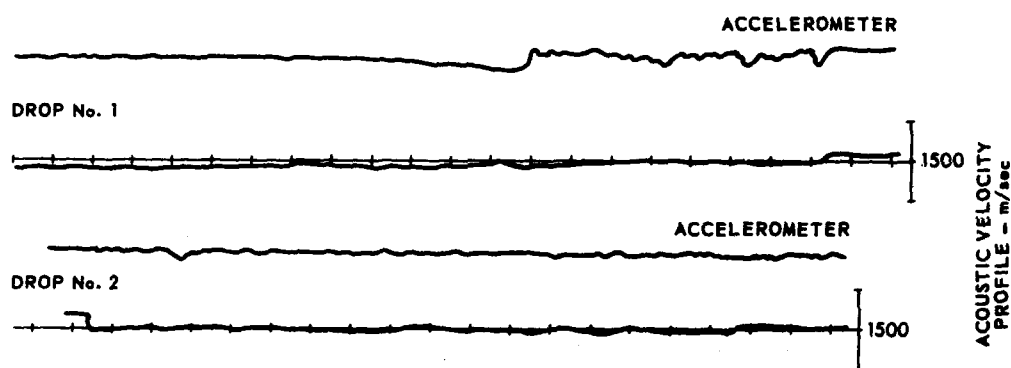

FIGURE 11
 ACOUSTIC VELOCITY PROFILES AND ACCELEROMETER OUTPUTS
 FOR TWO CORES IN THE GULF OF MEXICO
 HORIZONTAL SCALE: 0.1 sec/div
 PROFILE VERTICAL SCALE: 100 m/sec/div

ARL - UT
 AS-72-28
 LDH - DR
 1 - 12 - 72

pulse repetition rate of 200 pulses/sec this gives an acoustic velocity measurement essentially every 2 cm. Measurements of acoustic velocity made in the laboratory at A&M of 1509, 1505, and 1490 m/sec at 40, 60, and 80 cm respectively are in good agreement with the value of 1500 m/sec given in Fig. 11, Drop No. 2. The far lefthand side of the trace shows a sharp increase. This was caused by the electrical cable pulling in two when a coil of cable on the corer failed to properly break loose. This caused a delay in further coring until the cable was repaired. Core 3 was taken further west of the delta, with a bottom of stiff clay. The equipment failed to operate properly and did not provide an acoustic profile. Also, the core barrel was bent during retrieval and this caused further delay.

The last field trip was held on 22-23 November 1971, in Baffin Bay, Texas, aboard a barge operated by The University of Texas Marine Sciences Institute of Port Aransas, Texas. No further modifications were made to the equipment except, instead of using the cutting head on a regular coring tool, a hand corer was constructed and used. This hand corer was constructed of aluminum tubing 3 1/4 in. i.d. and 3 1/2 in. o.d., and in two sections totaling 28 ft in length. A regular 2 3/4 in. i.d. plastic core liner was contained in the bottom 14 ft so that the core samples could be retained for laboratory analysis. The cutting head for the piston corer fitted this arrangement without modification.

Six cores were taken on this trip with an acoustic velocity profile obtained for each core. The first three cores were taken well up into Baffin Bay, whereas the second three cores were taken close to the junction of Baffin Bay and Laguna Madre. Water depth varied from 6 to 10 ft. Before each coring operation the temperature and salinity of the water was measured for a calibration of the equipment. Figure 12 displays the acoustic velocity profiles obtained for each of the six cores. Displayed along with each *in situ* profile is a profile obtained in the lab from the core samples retained inside the plastic core liner.

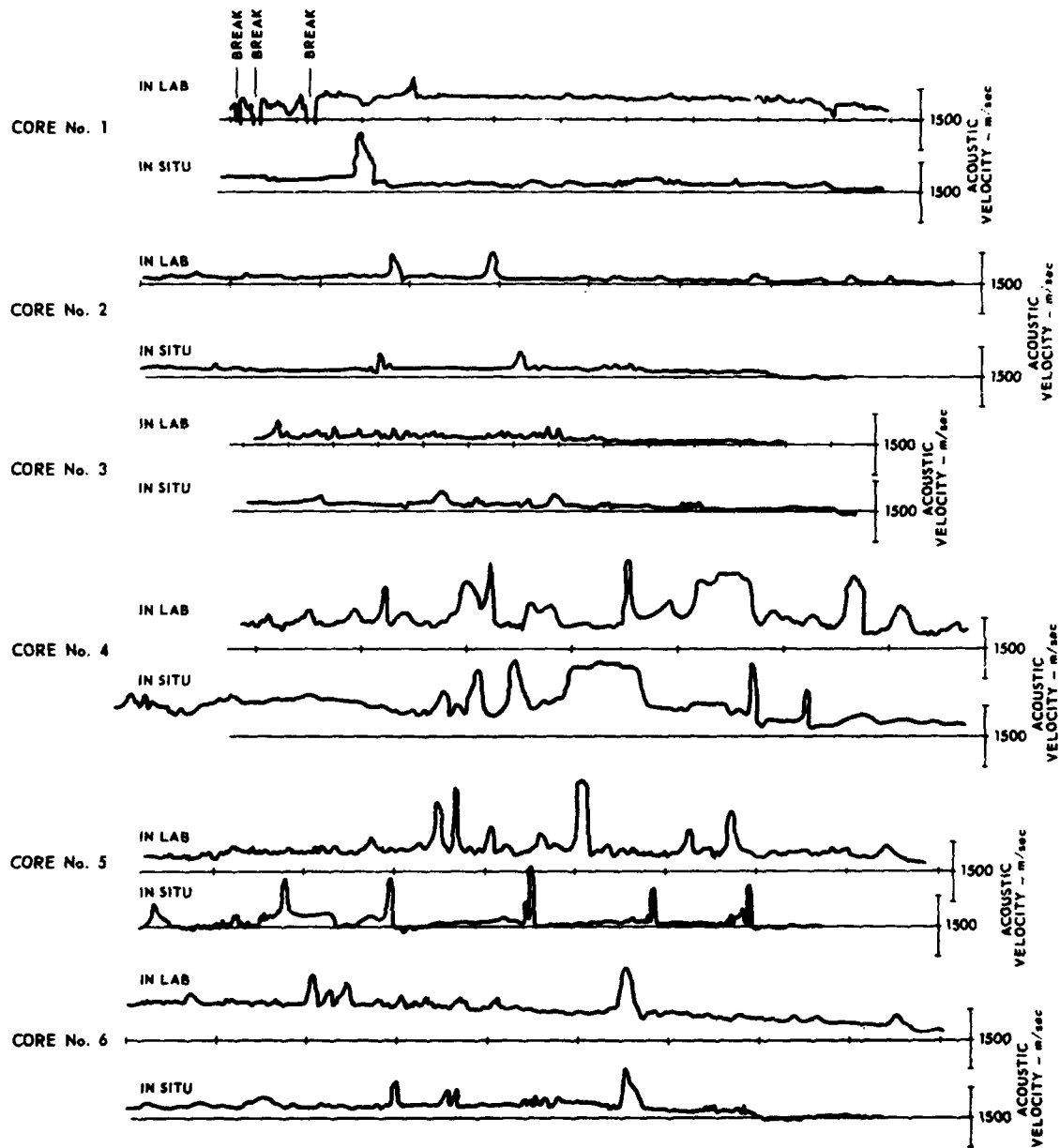

FIGURE 12
 IN LAB AND IN SITU ACOUSTIC VELOCITY PROFILES
 OF SEDIMENTS IN BAFFIN BAY, TEXAS

IN LAB PROFILES VERTICAL SCALE: 55 m/sec/div
 HORIZONTAL SCALE: 1 ft/div
 IN SITU PROFILES VERTICAL SCALE: 85 m/sec/div
 HORIZONTAL SCALE: NONE

ARL - UT
 85-72-29
 LDH - DR
 1-12-72

The core samples varied in length from 9 to 13 ft. The measurement of acoustic velocity profiles in the lab were obtained by constructing an auxiliary set of transducers to be used in conjunction with the electronics for the acoustic profilometer. These transducers were encapsulated in a rigid epoxy except for the face, which was covered by a soft RTV rubber. The transducers were mounted on a frame such that the transducers could be clamped on opposite sides of the plastic core liner and moved along the length. The soft RTV rubber provided good coupling for the sound through the liner and across the sediment sample and also provided for a fixed path length for the acoustic transmission with minimum distortion of the plastic core liner. Figure 13 shows a photograph of this transducer arrangement. A short section of plastic liner was filled with deionized water and plugged to provide a calibration for the equipment. The cores were greased on the outside and the transducers were moved slowly along the core while the output of the time delay to voltage converter was recorded on magnetic tape. An approximate horizontal scale is included on the resulting traces.

There are several factors to consider in visually correlating the *in situ* and in lab profiles. First, the *in situ* profile has no horizontal scale since no method to record the depth of the coring tool was available and rate at which it penetrated the bottom varied because it was pushed in by hand. The *in situ* traces shown in Fig. 12 were made by removing portions of the record which had long constant values (i.e., the time during which the core was not pushed through the bottom). This is arbitrary and introduces obvious errors. In addition, the corer could not be pushed uniformly so that the remaining record has a variable scale. Notice also that the vertical scales differ for the two measurements. Because the in lab measurements were made after the plastic liner had traveled 200 miles by truck and been stored for about two weeks, the ends and especially the water sediment interface had deteriorated.



FIGURE 13
TRANSDUCER ARRANGEMENT FOR
CORE LINER VELOCITY MEASUREMENTS

In Fig. 12 the measurements for Core 1 shows the poorest agreement of the six. The in lab measurement shows discontinuities at the lower end (left side) that may obscure the only prominent feature (single peak indicating a layer with increased velocity) in the *in situ* measurement.

For Core 2 the agreement is better. Two prominent high velocity layers appear in both measurements with approximately equal values. Other smaller features are also similar.

For Core 3 the numerous small features from the in lab measurement are present and of similar value for the *in situ* measurement, but the two prominent high velocity layers in the *in situ* trace are not present in the lab measurement. The reason is not known.

Cores 4 and 5 show much greater complexity and this complexity is present for both measurements. It is not possible to match the two traces in detail, but the agreement in complexity and value is encouraging.

Core 6 also shows similar agreement, and also illustrates the errors in the *in situ* measurement horizontal scale. The highest peak has been aligned, but the three left hand peaks in the lab measurements are matched to the single peak and double peak to the left of the *in situ* measurement. The smaller value variations on either side of the large peak are also present in both traces.

Even if detailed agreement is not permitted because of the limitation in *in situ* horizontal scale, agreement in kind and in measured values across the six cores is gratifying.