

AD737846



Research and Development Technical Report  
ECOM-0243-5

# THREE-COLOR PLASMA-PANEL DISPLAY DEVICE

## FIFTH QUARTERLY REPORT

BY

H. J. HOEHN, R. A. MARTEL, W. D. PETTY, AND F. H. BROWN

DECEMBER 1971

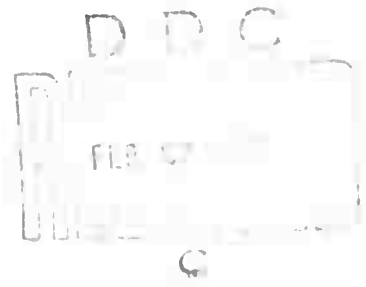

### DISTRIBUTION STATEMENT

Approved for public release; distribution unlimited.

Reproduced by  
NATIONAL TECHNICAL  
INFORMATION SERVICE  
Springfield, Va 22151

# ECOM

UNITED STATES ARMY ELECTRONICS COMMAND · FORT MONMOUTH, N.J.

Contract DAAB07-70-C-0243  
Owens-Illinois, Inc.  
Toledo, Ohio 43651

SEE AD 734928

**MISSING PAGE  
NUMBERS ARE BLANK  
AND WERE NOT  
FILMED**

# NOTICES

## Disclaimers

The findings in this report are not to be construed as an official Department of the Army position, unless so designated by other authorized documents.

The citation of trade names and names of manufacturers in this report is not to be construed as official Government indorsement or approval of commercial products or services referenced herein.

## Disposition

Destroy this report when it is no longer needed. Do not return it to the originator.

ADDITIONAL TO  
DATE  
BY  
REASON FOR  
REVISION  
BY  
DATE  
A

✓

## DOCUMENT CONTROL DATA - R &amp; D

Security classification of title, body of abstract and indexing annotation must be entered when the overall report is classified

1. ORIGINATING ACTIVITY (Corporate author) <b>Owens-Illinois, Inc. P. O. Box 1035 Toledo, Ohio 43651</b>		2a. REPORT SECURITY CLASSIFICATION <b>Unclassified</b>	
3. REPORT TITLE <b>THREE-COLOR PLASMA PANEL DISPLAY DEVICE</b>		2b. GROUP	
4. DESCRIPTIVE NOTES (Type of report and, inclusive dates) <b>QUARTERLY TECHNICAL REPORT - 1 July 1971 to 30 September 1971</b>			
5. AUTHOR(S) (First name, middle initial, last name) <b>H. J. Hoehn, R. A. Martel, W. D. Petty and F. H. Brown</b>			
6. REPORT DATE <b>December 1971</b>	7a. TOTAL NO. OF PAGES <b>31</b>	7b. NO. OF REFS	
8a. CONTRACT OR GRANT NO. <b>DAAB07-70-C-0243</b>	9a. ORIGINATOR'S REPORT NUMBER(S) <b>FIFTH QUARTERLY REPORT</b>		
b. PROJECT NO. <b>DA 7910.22.703.05.01</b>	9b. OTHER REPORT NUMBER (Any other numbers that may be assigned this report) <b>ECOM - 0243-5</b>		
10. DISTRIBUTION STATEMENT <b>Approved for public release; distribution unlimited.</b>			
11. SUPPLEMENTARY NOTES <b>Sponsored by: Advanced Research Projects Agency ARPA Order No. 1582</b>		12. SPONSORING MILITARY ACTIVITY <b>U. S. Army Electronics Command Ft. Monmouth, New Jersey 07703 AMSEL-TL-QD</b>	
13. ABSTRACT <p>The objectives of this program are to design, fabricate, and evaluate a plasma panel display device having three-color capability and to investigate and develop a technique for operating such a device with at least three levels of intensity.</p> <p>Three-color DIGIVUE® display/memory panels have been produced by the incorporation of selected photoluminescent phosphors into Xe-filled devices. Over forty phosphor panels with 128 X 128 electrode lines were evaluated. Seven of these had 60 electrode lines per linear inch and the others were 33 lines per inch. Phosphor deposition techniques have been extended to provide uniform coatings over larger areas. A "multiple photomaster" system has been devised to compensate for variations in panel substrate movement during normal processing. A work for three-color 512 X 512 line panels has been procured and the fabrication of electrode plates and multiple photomaster has begun. An electronic drive system capable of addressing a 128 X 128 line area was completed and checked out. The unit has sustain waveform controls suitable for operating panels in multiple states of intensity.</p>			

DD FORM 1473 (PAGE 1)

S/N 0101-807-6811

KEY WORDS

LINK A

LINK B

LINK C

ROLE

WT

ROLE

WT

ROLE

WT

Plasma Panel Display

Three-Color Display

Multiple Levels of Intensity

# THREE-COLOR PLASMA PANEL DISPLAY DEVICE

FIFTH QUARTERLY REPORT

1 July 1971 to 30 September 1971

CONTRACT NO. DAAB07-70-C-0243  
DA Task No. 7910.22-793.05.01

## DISTRIBUTION STATEMENT

Approved for public release;  
distribution unlimited.

PREPARED BY  
H. J. HOEHN, R. A. MARTEL, W. D. PETTY, AND F. H. BROWN

Electro-Optical Display Development Department

Owens-Illinois, Incorporated

Toledo, Ohio

FOR

U. S. ARMY ELECTRONICS COMMAND, FORT MONMOUTH, NEW JERSEY

Sponsored By

Advanced Research Projects Agency

ARPA Order No. 1582

## FOREWORD

This Fifth Quarterly Report describes research and development performed by Owens-Illinois, Inc., under Contract DAAB07-70-C-0243. The work is being done in the Electro-Optical Display Development Department (EODD), E. A. Oster, General Manager. Activities related to phosphor deposition and process development are under the technical direction of R. A. Martel. Panel evaluation is under the direction of R. W. Burke. The investigation and development of technology for circuitry to operate devices at multiple levels of intensity is under the direction of W. D. Petty. The program manager is H. J. Hoehn, Manager, Display Panel Development. Members of the Technical Staff other than the authors who have contributed to this project during the fifth quarter are: W. W. Bode, R. Burke, A. Fazio, M. S. Hall, L. Lohmann, P. Mansur, C. Salisbury, R. Browne, R. N. Clark, R. W. Gensler, T. Kaszynski, D. S. Kitsmiller, R. King, C. Malin, W. McCreary, N. Photos, M. Riggsbee, J. K. Rough, and M. J. Zayac. The ECOM Project Engineers are M. Crost and I. Reingold.

## ABSTRACT

The objectives of this program are to design, fabricate, and evaluate a plasma panel display device having three-color capability and to investigate and develop a technique for operating such a device with at least three levels of intensity.

Three color DIGIVUE<sup>®</sup> display/memory panels have been produced by the incorporation of selected photoluminescent phosphors into Xe-filled devices. Over forty phosphor panels with 128 X 128 electrode-lines were evaluated. Seven of these had 60 electrode-lines per linear inch, and the others were 33 lines per inch. Phosphor deposition techniques have been extended to provide uniform coatings over larger areas. A "multiple photo-master" system has been devised to compensate for variations in panel-substrate movement during normal processing. Artwork for three-color 512 X 512-line panels has been procured, and the fabrication of electrode plates and multiple photo-masters has begun. An electronic drive system capable of addressing a 128 X 128-line area was completed and checked out. The unit has sustain-waveform controls suitable for operating panels in multiple states of intensity.

## TABLE OF CONTENTS

<u>SECTION</u>	<u>PAGE</u>
Foreword . . . . .	ii
Abstract . . . . .	iii
1. Introduction . . . . .	1
2. Substrate Stabilization . . . . .	2
3. Phosphor Deposition . . . . .	8
3.1 Mechanism of Phosphor-Attachment . . . . .	9
4. Sealing and Registration . . . . .	10
5. 512-60 Color Activity . . . . .	11
6. Panel Evaluation . . . . .	13
6.1 Static-Test Results . . . . .	13
6.2 Data Interpretation . . . . .	13
6.3 Analysis of Static-Test Data . . . . .	18
6.4 Optical Crosstalk . . . . .	19
7. Drive Circuit Development . . . . .	20
8. Publications, Lectures, Reports and Conferences . . . . .	21
9. Program for Sixth Quarter . . . . .	22
Distribution List . . . . .	23

# LIST OF ILLUSTRATIONS

<u>FIGURE</u>		<u>PAGE</u>
1	#128-60 Plate Stability Study . . . . .	3
2	#128-60 Plate Stability Study . . . . .	5
3	#128-60 Plate Stability Study . . . . .	6
4	#512-60 3-Color Design . . . . .	12
5	Static Voltage Characteristics . . . . .	15
6	Typical Dynamic Characteristics . . . . .	17

LIST OF TABLES

<u>TABLE</u>		<u>PAGE</u>
1	Static Characteristic Data . . . . .	16
2	Average Static Characteristics . . . . .	18

## 1. INTRODUCTION

Three-color plasma panel display devices have been fabricated and functionally demonstrated at 33-1/3 lpi and at 60 lpi total cell-resolution. The general approach was to incorporate photoluminescent phosphors into the Owens-Illinois DIGIVUE<sup>®</sup> display/memory panel. This is a glass-sealed, open-volume panel consisting of two glass substrates with orthogonal electrode lines covered by dielectric layers of glass.

The ultimate objective of this program is to fabricate a 3-color panel with 512 X 512 color triads. With 60 lines-per-inch total cell-resolution this will require a total display-area of 17" X 17" with 1024 X 1024 electrode-lines. The panel should be capable of being addressed and operated with 3 levels of intensity, (including the "off" state).

Prior to this report, panels with 128 X 128 electrode-lines have been fabricated with about 4,000 individual dots of each of three phosphor-elements, red, blue, and green.

Major emphasis during the fifth quarter was directed toward the following:

- (a) Improvement of substrate thermal stabilization.
- (b) Modification of phosphor deposition, photo-processing, and attachment techniques to provide suitable uniformity over a 17" X 17" area.
- (c) The design and procurement of artwork for a 512 X 512-line 3-color panel.
- (d) The evaluation of static performance characteristics for 128 X 128 lines.
- (e) The construction of a dynamic test unit to drive a 128 X 128-line panel in a 3-level mode.

## 2. SUBSTRATE STABILIZATION

At the beginning of this quarter a reliable electrode-system, developed by Owens-Illinois, Inc., was adopted for use in the preparation of parts for this effort. This electrode-system involves the use of thick-film technology, wherein the process requires that the substrates be subjected to two high-temperature cycles prior to the actual formation of the electrode-pattern per se. It seemed reasonable to assume that these high-temperature cycles will aid in dimensionally stabilizing the substrates.

The electrode-pattern used to prepare parts during this quarter is designed to provide 128 active electrodes, 3.0 - 3.3 mils in width, at a resolution of 60 lines per inch. Included in the pattern are a group of tick-marks, to be used for phosphor alignment and plate registration. Two sets of these tick-marks are located 5.5" apart on an imaginary reference line which is parallel to and centered with the electrode-pattern. These tick-marks are indelibly transferrad onto the substrate at the same time that the electrode-pattern is formed. These marks are used to insure correct placement of each phosphor color-field on a given substrate. They also serve another useful purpose, in that they can be used to measure accurately dimensional changes in the substrate which might occur during subsequent processing operations. This is accomplished by using the photomaster from which the electrode part was made. The photomaster is placed in contact with the parts, adjusted for parallel alignment with the electrode-pattern on the part; one set of tick-marks on one end of the master is placed in direct coincidence with the corresponding set of tick marks on the part; and finally, the displacement between the photomaster tick-marks and those on the part located at the other end of both plates is measured, using a 60 X monocular microscope with a calibrated measuring eyepiece.

A group of 38 parts with the 128-60 pattern were prepared, 30 of which were also coated with dielectric. Using the method described above, all of these parts were examined for dimensional changes, and the results are depicted in Figure 1. As shown, all plates expanded through both the electrode and dielectric cure-cycles. Those plates with only cured electrodes expanded an average of 2.2 mils per inch, whereas those plates with both cured electrodes and dielectric expanded an average of 3.1 mils per inch.

In view of these results, a new group of plates was prepared, using a modified process. The bare substrates were subjected to the following pre-heat treatment:

Up-rate - 3°F/min.

Plateau - 1160°F for 1 hour

Down-rate - 1°F/min.

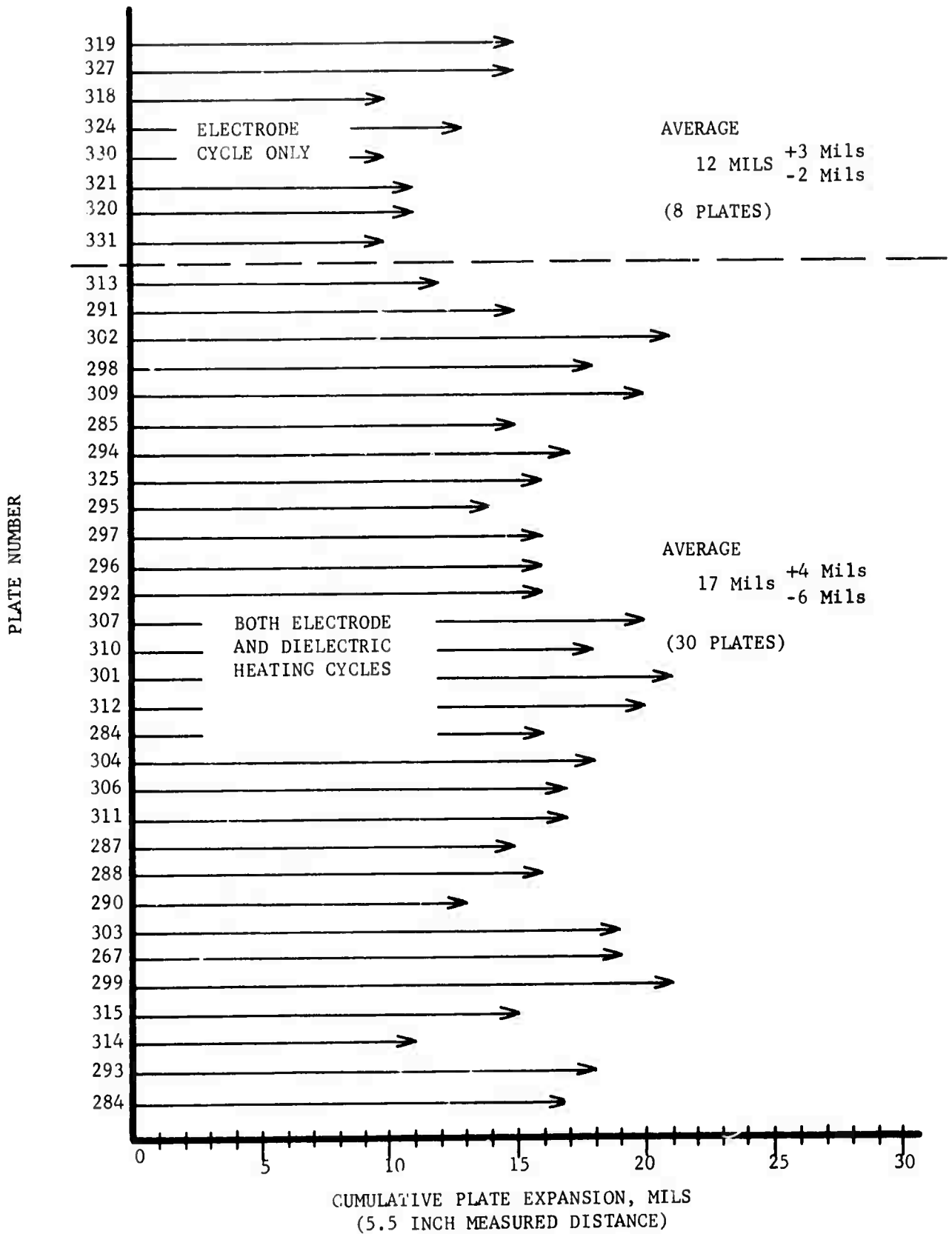

FIGURE 1. 128-60 PLATE STABILITY STUDY

These parts were then processed in the standard manner but measured for dimensional changes after the electrode cure and also after the dielectric cure. Figure 2 depicts the results obtained. Average expansion through electrode cure is 0.8 mil per inch, and 1.9 mils per inch after both electrode and dielectric cure-cycles. Although the pre-heat treatment significantly reduced dimensional changes occurring in the plates during normal processing, these changes are still large enough to cause significant misalignment conditions for both phosphor deposition and final device-assembly, particularly in relation to larger assemblies.

In a further attempt to reduce dimensional changes in the substrate during processing, a third group of plain substrates were subjected to a new pre-heat treatment:

Up-rate - 3°F/min.

Plateau - 1170°F for 3 hours

Down-rate - 1°F/min.

This heat-cycle accommodates both a peak temperature and dwell-time which exceeds those which a substrate will normally experience in standard processing. It was therefore judged that all changes which occurred in the normal processing-sequence following the above described substrate pretreatment would be minimal and of no consequence in obtaining satisfactory alignment in subsequent operations.

Results on this third group of plates are shown in Figure 3. Parts through the electrode-cycle show an average dimensional increase of 0.8 mil per inch, and 1.6 mils per inch for parts through both the electrode and dielectric cycles, indicating no appreciable improvement over the second group of plates.

Examining the results obtained thus far and recognizing that glass is, in effect, a super-cooled liquid, it would appear that the required processing heat-cycles are of such a magnitude as to cause the substrate material to flow repeatedly and, in terms of this application, significantly.

The data also indicate that the spread or deviation in expansion from the average after the dielectric-cycle has narrowed considerably for those plates which were pre-heat treated:

1st group - 10.0 mils

2nd group - 4.0 mils

3rd group - 1.5 mils

On that basis, compensation for substrate movement could possibly be made in either the electrode or phosphor-placement artwork; however, this may be very difficult to achieve in reality, and it is dependent upon the accurate predictability of substrate movement in the process. Another approach, which may be more

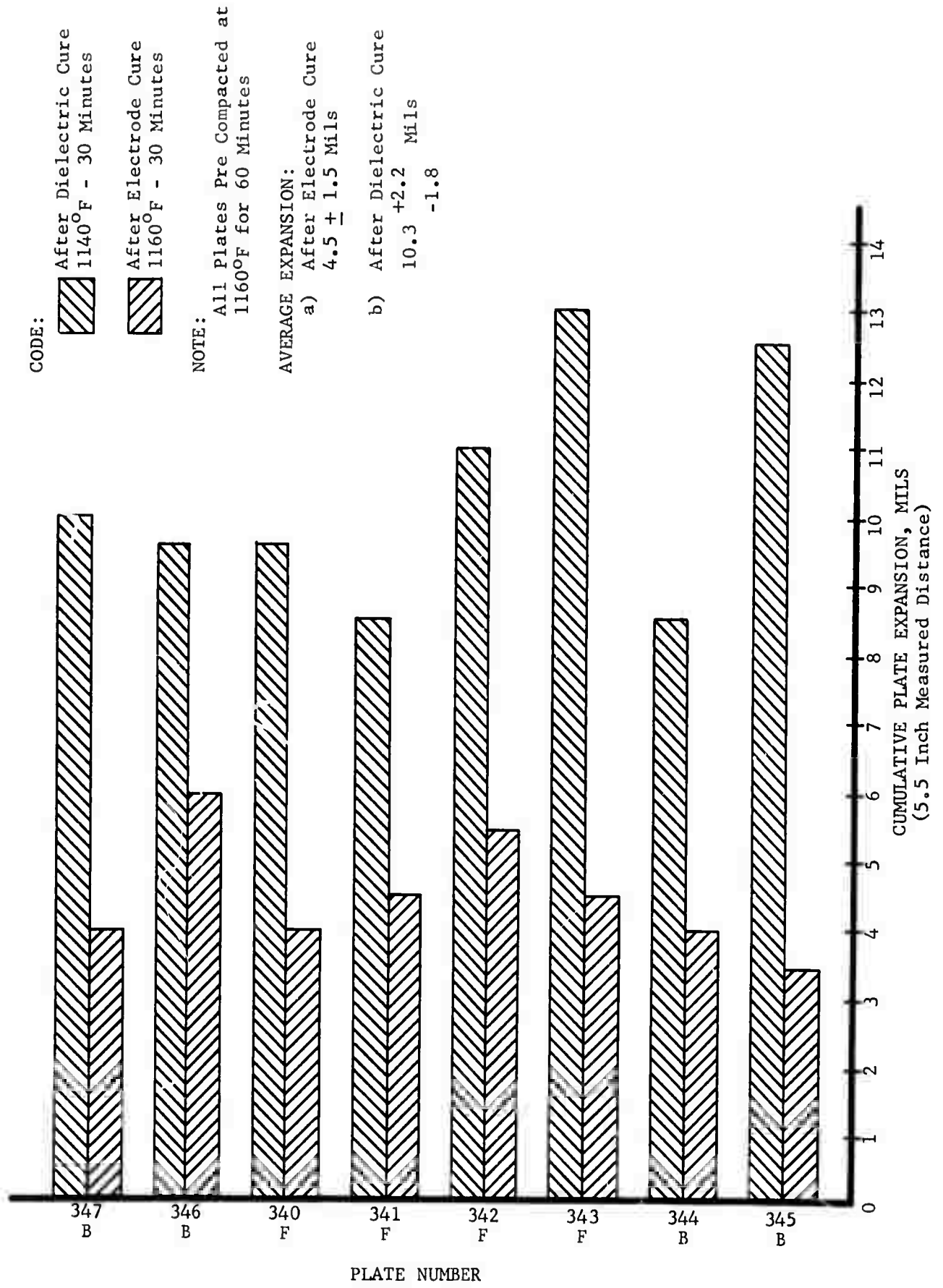

FIGURE 2. 128-60 PLATE STABILITY STUDY

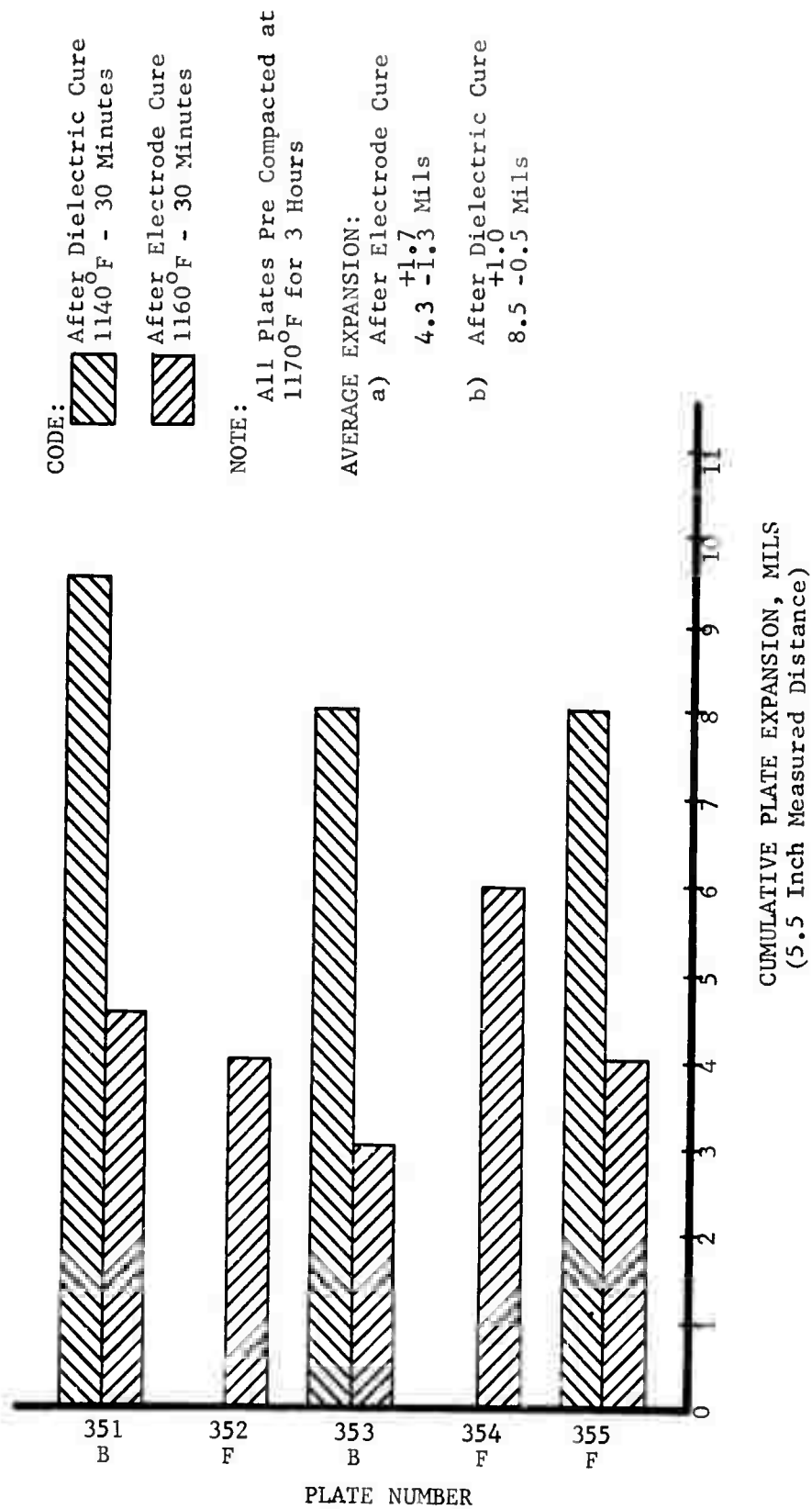

FIGURE 3. 128-60 PLATE STABILITY STUDY

practical but certainly not without some similar drawbacks, is presently being considered. This method will involve the preparation of thin-film metal photomasters on glass which can be subjected to heat-cycles similar to those used for the fabrication of parts for device assemblies. Conventional chrome masks would not survive this processing, but this problem can be readily circumvented by using a thin-film metal system developed by Owens-Illinois, Inc., and employed in the fabrication of standard DIGIVUE<sup>®</sup> display/memory panels. By creating an inventory of a few photomasters prepared in this manner and generating displacement data on each master, the selection of a photomaster which will suitably match a fabricated part should be fairly simple. This method may very well provide a solution to both phosphor-alignment and plate-registration for assembly.

### 3. PHOSPHOR DEPOSITION

The transfer of the phosphor-deposition technology, developed earlier at the Owens-Illinois Corporate Research Laboratory in Okemos, Michigan, was completed, and this capability was successfully demonstrated in the new DIGIVUE® display/memory facilities at Levis Development Park in Perrysburg, Ohio. Subsequent to this effort the activities were concentrated toward the adaptation of this process to the fabrication of larger 3-color display panels - ultimately the 3-color 1024-60 panel.

Prior to this quarter the technique used for applying the Cermifax photoresist (from Kodak Pathe') was manual spraying. Recognizing that this method is adequate for use on small parts but would probably not satisfy the thickness-uniformity requirement on larger parts, all of the necessary parameter-adjustments were made to apply the Cermifax material by using a completely automatic spray system which can ultimately accommodate the 3-color 1024-60 parts. This automatic system is presently being used to apply the photoresist on all parts fabricated under this effort. The parameters for correct exposure of the photoresist have also been established on an automated unit, also capable of handling the larger sizes.

The attachment of phosphor to the Cermifax photoresist is dependent on the tackiness of the heated, unexposed photoresist. The degree of tackiness, among other factors such as particle size, etc., governs the uniformity of the phosphor-deposit. Since the degree of tackiness is dependent on temperature, it is of paramount importance to maintain adequate temperature uniformity over the entire surface of interest during the actual phosphor-attachment (dusting) operation. Again, maintaining relatively good temperature-uniformity over a small area (approximately 4" X 4") is readily feasible, but it will become increasingly more difficult to achieve as the size of the substrate is increased. In anticipation of this problem arising on larger-size plates, a back-up method has been investigated, and its development is nearing completion. This approach provides a "cold" method of attaching phosphor to the resist. It employs the use of dichromate-sensitized polyvinyl-alcohol photoresist (PVA resist), commonly used in the CRT industry. The resist is applied, for this purpose, using an automatic spray system, dried, exposed using the automated exposure system, and developed, leaving resist only where phosphor is to be subsequently attached. A slurry of phosphor/water/alcohol is prepared and applied at room-temperature over the entire area coated with resist. The water/alcohol blend attacks the resist, causing it to swell and become tacky, thus permitting the phosphor to become attached and held more firmly as the water/alcohol blend evaporates and the resist hardens. The resist is then polymerized with heat to permit deposition of another layer of phosphor. These steps are repeated for each application of phosphor necessary. Several plates have been successfully coated with phosphor by this method, and a visual examination of the deposit has revealed a high degree of uniformity and high packing-density of the adhered phosphor-particles. A suitable method for permanently attaching the phosphor to the glass-dielectric is presently being investigated.

A modification of the above process has also been investigated. This approach involves phosphor-pigmentation of the PVA resist. However, this method produced poorly defined phosphor-deposits, because of light-scatter caused by the phosphor during photo-exposure and/or incomplete exposure. For this reason, and because of the success achieved by the post-pigmentation process, this latter approach has been abandoned.

### 3.1 Mechanism of Phosphor-Attachment

A scanning electron-microscope at Michigan State University was used to examine the attached P-1 phosphor on a plate. The plate was cut into small pieces which were vapor-coated with carbon to prevent charge build-up. The surface was examined at magnifications to 9000X. Four observations were made.

1. There are several holes in the phosphor-layer where particles did not adhere using the Cermifax process.
2. There is a particle-size distribution between  $1\mu\text{m}$  and  $15\mu\text{m}$ , with about 90% of the particles below  $5\mu\text{m}$ .
3. The dielectric layer rises to form a meniscus around each grain, which attaches the particle to the glass.
4. Some phosphor-grains were found in "phosphor-free" areas. This shows a need for more closely controlled procedures.

#### 4. SEALING AND REGISTRATION

The following 128-60 devices were completed during this quarter, using parts which were in process during the latter period of the fourth quarter.

<u>Device #</u>	<u>Front Plate</u>	<u>Back Plate</u>
4013	Multi-color donuts with surrounding Sylvania #147 u.v.-absorbing material	Sylvania #147 ABS material with dot windows
4014	Multi-Color Donuts only	Sylvania #147 ABS material with dot windows
4016	Multi-Color Donuts	Standard
4017	Green Donuts with Sylvania #147 u.v.-absorbing material surrounding	Standard
4019	Multi-Color Donuts Only	Standard

A 3-MB micro-projector, manufactured by Stokes and Yale, Inc., was procured by Owens-Illinois funding during this quarter. This unit was first evaluated from the standpoint of both phosphor-deposition alignment and plate-registration for sealing. The results indicated that the depth-of-focus of this unit, using either a 5X or 10X lens, is adequate to permit viewing of both plates for sealing-registration purposes and, with proper light-filtering, will be useful in aligning the phosphor-pattern photomaster to the electrode/dielectric-coated part in the phosphor-deposition operation. Based on these results, this unit was purchased, and a second unit has been ordered. As described in the Fourth Quarterly Report, two microprojectors will be required to view two sets of tick-marks simultaneously and thus permit correct alignment.

## 5. 512-60 COLOR ACTIVITY

In the early period of this quarter, steps were taken to design the electrode, phosphor, and u.v.-absorbing patterns required in the fabrication of 512-60-size panels. The electrode pattern consists of 512 interlaced electrodes, 3.3 mils in width, and an additional 32 border electrodes for conditioning purposes. The phosphor-pattern consists of paired rectangular areas, 2 X 8 mils each, with a separation of 4 X 8 mils between rectangles within a given pair, and where each pair represents a discharge-site in a finished panel. This pattern is further designed to permit deposition of the 3 phosphor-colors and a fourth position, which can be filled with another phosphor or left blank for test purposes. It is basically a quadrad pattern, which, in conjunction with the interlaced electrode-pattern, will permit static-testing of each color-field separately - an important feature which does not exist in the 128-60 artwork. See Figure 4. The U.V.-absorbin pattern consists of solid 8 X 8 mils squares on 16.7 mils centers, which will be used to mask out phosphor and dielectric areas at each discharge-site in the application of either U.V.-absorbing layers and/or high-contrast-inducing layers. Included in all of the patterns are groups of tick-marks to be used for phosphor-alignment and plate-registration steps in the process. In addition, these marks can be used for measuring actual plate dimensional changes, which could occur during processing.

Drawings were prepared; the artwork and photomaster were ordered and have been received.

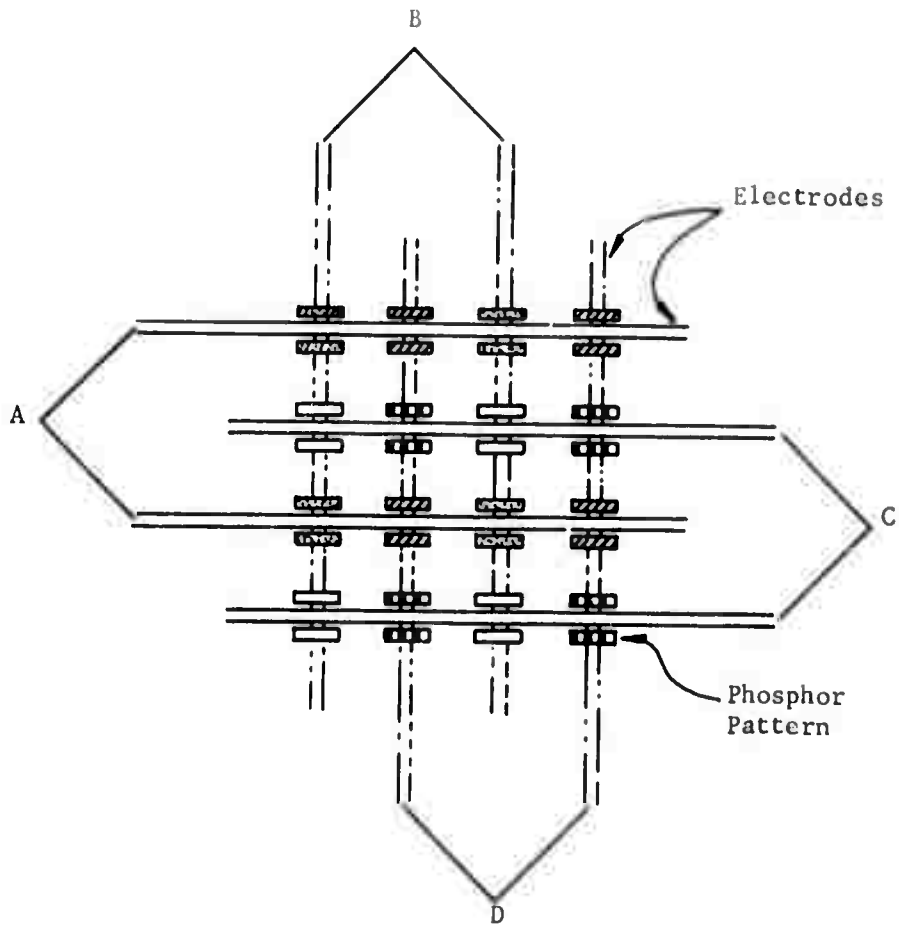

Powered Electrode Sets	Color Emission	Phosphor Color Code
A/B	Red	
C/B	Blank (Optional)	
A/D	Blue	
C/D	Green	

FIGURE 4. #512-60 3-COLOR DESIGN

## 6. PANEL EVALUATION

### 6.1 Static-Test Results

Static measurements were made on 42 Xenon-filled phosphor-panels over 128 X 128 lines.

Static data are taken by driving the full panel with a "sustain" generator. The voltage is raised until a discharge occurs at one or more cell-sites. This is the minimum turn-on voltage  $V_f(\text{min})$ , and this value is recorded. The sustainer voltage is then raised until all cells turn on, giving a measure of the maximum turn-on voltage  $V_f(\text{max})$ . The voltage is then lowered, and the maximum turn-off voltage  $V_E(\text{max})$  and minimum turn-off voltage  $V_E(\text{min})$  are measured in a similar manner. The static operating characteristics of the panel are then determined from Equations 1 through 9.

The significance of these performance factors can be understood by reference to Figure 5, which shows a plot of the percentage of cells "on" as a function of applied sustainer voltage.

The static characteristics of the 42 panels tested are given in Table 1.

### 6.2 Data Interpretation

Static characteristics are a convenient means of evaluating panel performance, since the measurements can be quickly and easily made. Since no individual cell-addressing is required, all electrodes on each edge of the panel can be shorted out, greatly simplifying connection to the electronic test-system. In real usage, however, each individual cell in the panel must be capable of being addressed and turned on or off selectively without affecting any unaddressed cells. Static data can therefore only give a general indication of relative panel performance. It can detect panels which definitely cannot operate dynamically, but cannot guarantee that even the better static performers will necessarily be dynamically addressable. Dynamic performance depends on the electronic drive system used and is limited by panel-conditioning and cell-to-cell interactions which cannot be measured statically.

Figure 6 shows a typical set of dynamic voltage-characteristics for a DIGIVUE<sup>®</sup> display/memory panel. The pulse-voltage ( $V_p$ ) required to write or erase addressed cells is plotted as a function of "sustain" voltage. The useful "sustain" voltage range is seen to be limited by  $V_E(\text{max})$  and  $V_f(\text{min})$  from the static voltage measurements. Therefore, the maximum range of sustainer voltages over which it is at all possible to operate a panel is given by  $V_{opt}(R)$ .

The first requirement that a panel must meet to be dynamically addressable is that  $V_{opt}(R)$  be some positive value. That is,  $V_E(\text{max})$  must be less than  $V_f(\text{min})$ . The larger  $V_{opt}(R)$  is, the greater the probability that the panel will operate dynamically.

Firing voltage mean

$$VF(M) = \frac{VF(max) + VF(min)}{2} \quad \text{Equation 1}$$

Firing voltage range

$$VF(R) = VF(max) - VF(min) \quad \text{Equation 2}$$

Turn-on Figure of Merit

$$F-ON = \frac{VF(R) \times 100}{VF(M)} \quad \text{Equation 3}$$

Extinguishing voltage mean

$$VE(M) = \frac{VE(max) + VE(min)}{2} \quad \text{Equation 4}$$

Extinguishing voltage range

$$VE(R) = VE(max) - VE(min) \quad \text{Equation 5}$$

Turn-on Figure of Merit

$$F-OFF = \frac{VE(R) \times 100}{VE(M)} \quad \text{Equation 6}$$

Operating Mean

$$V-OPT(M) = \frac{VF(min) + VE(max)}{2} \quad \text{Equation 7}$$

Operating Range

$$V-OPT(R) = VF(min) - VE(max) \quad \text{Equation 8}$$

Operating Figure of Merit

$$F-OPT = \frac{V-OPT(R)}{V-OPT(M)} \times 100 \quad \text{Equation 9}$$

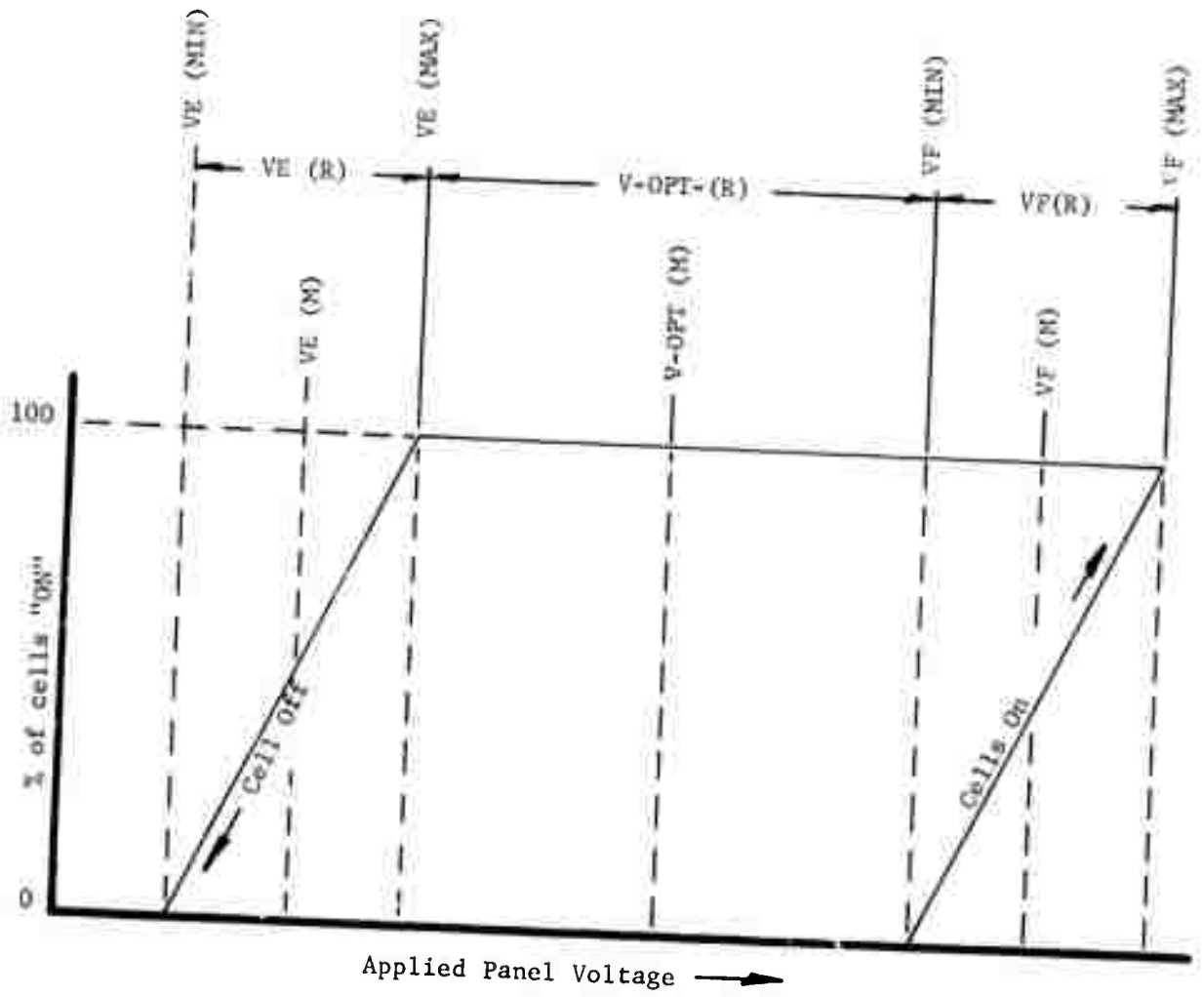

FIGURE 5. **STATIC VOLTAGE CHARACTERISTICS**

TABLE 1 - STATIC CHARACTERISTIC DATA

Panel No.	Description	Vopt Volts	Vopt(R) Volts	V <sub>F</sub> (R) Volts	V <sub>E</sub> (R) Volts	F-on %	F-off %
1.	R,G,B Donuts 3 color	260.55	-13.70	53.60	24.70	19.11	9.69
2.	Single G Donuts	278.95	-47.10	81.10	59.80	27.40	21.94
5.	3 Color Donut Quad	252.85	-19.10	45.60	26.10	17.14	10.47
20.	3 Quad G Donut	258.65	20.70	21.00	14.00	7.51	5.80
23.	3 Quad R,G,B	253.20	1.40	44.60	8.80	16.15	3.55
24.	1 Diag. Abraided, other 3/4 Covered G Dots	294.30	-28.40	63.60	41.00	20.39	14.24
25.	Multi-color (3 color)	275.25	-17.50	26.50	49.10	21.69	20.30
27.	Multi-Color Donut	257.45	- 2.70	20.10	38.60	7.55	16.12
28.	3/4 Coated Green	293.35	-24.10	50.50	72.30	16.47	26.85
32.	3/4 Covered G Dots	269.10	- 3.80	34.40	23.30	12.10	8.98
33.	G Donuts	263.25	- 3.30	39.10	20.50	13.80	7.98
34.	Triad Donuts	273.00	20.00	13.80	17.50	4.76	6.88
35.	R,G,B Dots & Donuts	258.55	- 3.50	49.20	20.20	17.49	8.07
36.	Multi-color, Back 1/2 panel frosted diag.	265.70	- 0.40	56.50	18.80	19.24	7.33
37.	Dots & Donuts R,G,B	288.45	-45.10	55.10	63.20	18.78	22.62
38.	G Dots	265.55	- 3.30	39.10	20.50	13.80	7.98
39.	R,G,B	263.60	9.60	34.50	14.30	12.08	5.68
40.	Multi-color donuts	248.90	- 4.80	57.50	15.00	20.89	6.15
41.	G Donuts	285.85	-86.10	111.40	93.80	37.32	33.26
42.	Multi-color Donuts	283.65	- 7.50	24.50	40.00	8.39	14.96
43.	Multi-color Donuts	302.65	-21.50	57.40	42.70	17.90	14.62
44.	G Donuts - 60 lpi	268.20	12.60	29.70	16.70	10.27	6.59
45.	G Donuts - 60 lpi	262.65	- 7.10	34.60	17.70	12.52	6.88
47.	G Donuts	271.70	2.80	42.70	22.50	14.50	8.69
48.	Multi-color	277.30	- 8.00	37.30	34.10	12.78	12.91
50.	Multi-color	251.55	12.10	33.70	14.20	12.28	5.96
51.	Multi-color Donut	264.00	19.60	39.20	16.30	13.36	6.63
53.		243.60	- 1.80	40.90	7.40	15.54	3.07
54.	Multi-color	259.15	18.30	46.60	7.90	15.98	3.21
55.	Multi-color	276.70	29.60	25.50	14.60	8.38	5.74
56.	G Donuts	265.95	9.10	35.10	18.50	12.19	7.34
57.	G Donuts	262.65	9.70	48.50	17.70	16.62	7.11
58.	Multi-color	257.40	- 5.60	58.80	21.10	20.71	8.45
59.	G Donuts	265.95	10.50	40.40	15.30	13.87	6.05
62.	Multi-color - 60 lpi	269.65	0.90	29.00	21.10	10.19	8.16
63.	G Donuts - 60 lpi	273.20	-13.60	61.30	20.50	20.64	7.60
64.	Multi-color on both F&B	253.65	2.70	48.00	9.20	17.21	3.72
66.	Bi-color combinations	253.00	- 2.40	66.10	10.10	23.21	4.05
70.	Multi-color	255.80	7.60	46.00	10.60	16.28	4.30
71.	Multi-color	250.85	-23.70	82.90	28.70	29.56	11.56
73.	Multi-color Donuts (60)	263.75	- 2.30	39.40	13.00	13.96	5.03
74.	Multi-color (60 lpi)	261.10	- 8.80	19.40	17.00	7.28	6.62

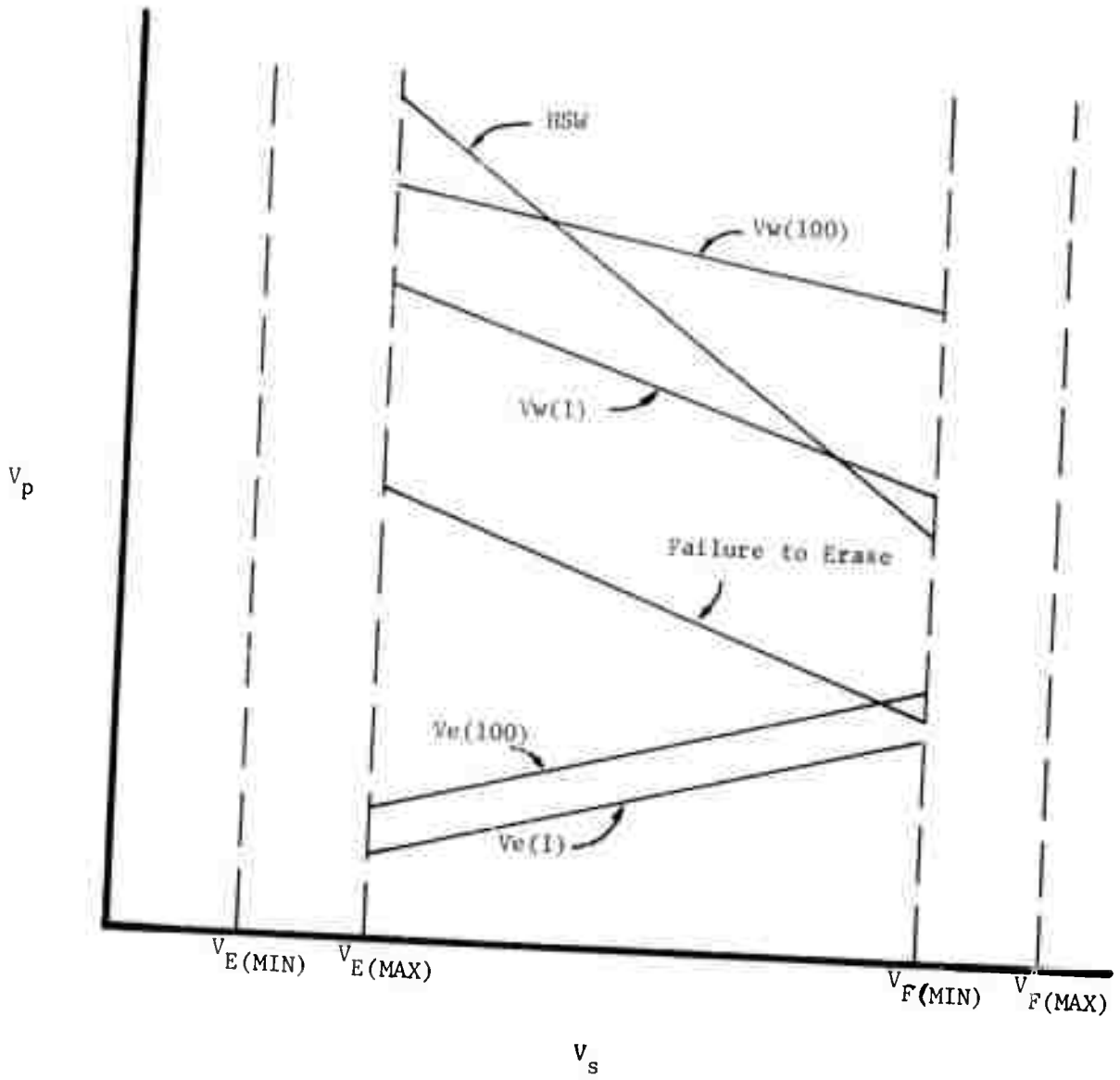

FIGURE 6. TYPICAL DYNAMIC CHARACTERISTICS

The write-voltage uniformity is illustrated by the spread between the curves of first "on" voltage  $V_w(1)$  and last "on" voltage  $V_w(100)$ . The erase-voltage uniformity is likewise shown by the  $\Delta V_p$  between the first "off",  $V_e(1)$ , and the last "off"  $V_e(100)$  curves.

The erase-pulse is generally referenced from the base-line, with half-voltage applied to the x and y electrodes. If the applied pulse-voltage exceeds twice  $V_e(1)$ , then some unaddressed cells will be erased somewhere in the panel. The Half-Select-Erase (HSE) curve is one of the boundaries of the operating erase-pulse range, as shown in Figure 6.

Since the applied erase-voltage must be greater than  $V_e(100)$ , it is desirable to have as little spread between  $V_e(1)$  and  $V_e(100)$  as possible. The same consideration applies to the write-pulse. Since the spread in write-and-erase-pulse uniformity is related to the static turn-on and turn-off uniformity, the smaller  $V_F(R)$  and  $V_E(R)$  are, the greater the probability of the panel operating well dynamically.

### 6.3 Analysis of Static-Test Data

Of the 42 panels tested, 14 had a positive  $V_{opt}(R)$ . Most of these had phosphor donuts with fairly good alignment.

The average static-characteristics of these 14 phosphor-panels, compared to typical values for a commercial DIGIVUE® display/memory panel, are given in Table 2.

	$V_{opt}$ Volts	$V_{opt}(R)$ Volts	$V_F(R)$ Volts	$V_E(R)$ Volts	F-on %	F-off %
Average of best 14 phosphor-panels	264	13.2	36.0	15.0	12.5	6.0
Typical Commercial Panel	149	20	6	5	3.7	3.7

TABLE 2 - AVERAGE STATIC-CHARACTERISTICS

The phosphor-panels were constructed using the same design-dimensions and manufacturing procedures as the commercial panels, except for the addition of the phosphors and the use of Xenon gas. However, two major factors influencing panel-performance are the gas-composition and the surface-material exposed to the gas at the electrode-intersections. With the donut-configuration, the influence of the phosphor is minimized with the phosphor being clear of the center of the discharge-area, which is hidden by the electrode-intersection. However, any

misalignment of the phosphor-donuts at any cell-location will affect the operating voltages of those cells and will make the overall electrical uniformity of the panel worse.

Pure Xenon gas has a high UV-radiation and is an excellent choice to obtain a high degree of photo-luminescence. This gas has some undesirable characteristics when used in plasma display panels. The Townsend  $\alpha$  coefficient is relatively low, causing the firing voltage to be rather high. In addition, the firing or breakdown voltage is fairly sensitive to gas-gap-spacing within the panel. For a given variation in this dimension within a panel, the use of pure Xenon gas will result in poorer turn-on and turn-off voltage uniformity.

Separate from this contract and using its own Corporate funds, Owens-Illinois has previously developed and reduced to practice several composite gas-mixtures which are suitable for exciting phosphors and have more desirable plasma-panel characteristics. The possibility of using one of these mixtures on this program will be considered.

#### 6.4 Optical Crosstalk

The investigation of optical crosstalk showed an apparent "shadowing" effect, i.e., the side of an "off" phosphor-donut nearer an "on" cell glows more brightly than the far side. More significantly, the near side of the next "off" phosphor-donut glows more brightly than the far side of the first. It was postulated that these results are due to the existence of ridges in the dielectric layer above the electrodes. The two halves of a donut would lie on different slopes of the ridge. A cross-section of a phosphor-carrying plate was mounted and polished, using standard metallographic equipment (courtesy of the Department of Metallurgy, Mechanics, and Material Science of Michigan State University). Microscopic examination confirmed that the donuts do indeed lie on ridges of dielectric glass above the electrodes.

## 7. DRIVE CIRCUIT DEVELOPMENT

The work done in the fifth quarter consisted primarily of completing the circuits begun in the fourth quarter. These circuits are to test the fundamental drive-and-address waveforms which will be implemented in the seventh and eighth quarters. In addition, the circuits will be used to examine various panel-operating parameters, such as dynamic operating range. The circuits produce a variable frequency, three-level, rectangular waveform in which the amplitude of each level may be independently adjusted from 0 to 400 volts. In addition, they are capable of producing three address-pulses, independent of each other in both phase and amplitude, whose amplitude is variable from 0 to 800 volts.

This drive/test circuit is now in operation and is capable of driving and addressing any point on a 128 X 128 panel. It has been tested on a standard, non-phosphor panel and a phosphor, three-color panel.

During this quarter, it was operated in a scan mode as a test of the circuits and as a preliminary test of the panel. These preliminary tests were performed with all three sustainer pulses set at the same amplitude. In this configuration, it has been shown possible to write selectively on an entire 128 X 128 element phosphor-panel.

## 8. PUBLICATIONS, LECTURES, REPORTS AND CONFERENCES

There were no publications or lectures resulting from the work under this contract during the period covered by this report.

### Reports:

The Fourth Quarterly Report for this Contract, covering the period from 1 April, 1971, to 30 June, 1971, was submitted to the U. S. Army Electronics Command, Fort Monmouth, New Jersey, during the present reporting period.

### Conferences:

On Friday, July 9, 1971, a conference was held at Ft. Monmouth.  
Attending were:

#### ECOM, Ft. Monmouth

M. Close  
J. Reingold

#### OWENS-ILLINOIS

M. S. Hall  
H. J. Hoehn  
H. G. Slottow  
R. A. Martel

## 9. PROGRAM FOR SIXTH QUARTER

1. Initiate fabrication of 3-color #512-60 parts and assemblies.
2. Fabricate and process thin-film metal photomasters and evaluate this method as a means of obtaining improved phosphor-alignment.
3. Continue to investigate materials which can enhance contrast and reduce optical crosstalk.
4. Design and initiate fabrication of fixturing which will permit improved phosphor-alignment and plate-registration in large-area devices.
5. Design and order artwork for the fabrication of 3-color, #1024-60 panels.
6. Procure #1024-60 substrates.
7. Complete evaluation of #128-60 drive-system for multistate operation.
8. Begin design of #1024-60 drive-system.