

AD 738851

AD

RE-TR-71-76

# DESIGN AND EVALUATION OF AN ENERGY DISSIPATING SPRING DEVICE



*Details of illustrations in  
this document may be better  
studied on microfiche*

## TECHNICAL REPORT

*Henry P. Swieskowski*

December 1971

**D D C**  
**RECEIVED**  
MAR 22 1972  
**REGISTRY**  
**B**

RESEARCH DIRECTORATE

WEAPONS LABORATORY AT ROCK ISLAND

RESEARCH, DEVELOPMENT AND ENGINEERING DIRECTORATE

U. S. ARMY WEAPONS COMMAND

Approved by  
NATIONAL TECHNICAL  
INFORMATION SERVICE  
Springfield, Va. 22151

Approved for public release, distribution unlimited.

23

**DISPOSITION INSTRUCTIONS:**

Destroy this report when it is no longer needed. Do not return it to the originator.

**DISCLAIMER:**

The findings of this report are not to be construed as an official Department of the Army position unless so designated by other authorized documents.

The citation of commercial products in this report does not constitute an official indorsement or approval of such products.

ACQUISITION FOR	
CFSTI	WRITE SECTION <input checked="" type="checkbox"/>
DSIC	DIFF SECTION <input type="checkbox"/>
UNCLASSIFIED	<input type="checkbox"/>
POST/REVISION	
BY	
INSTRUCTION/AVAILABILITY CODES	
CODE	AVAIL. and/or SPECIAL
A	

Unclassified

Security Classification

DOCUMENT CONTROL DATA - R & D

(Security classification of title, body of abstract and indexing annotation must be entered when the overall report is classified)

1. ORIGINATING ACTIVITY (Corporate author) U. S. Army Weapons Command Research, Dev. and Eng. Directorate Rock Island, Illinois 61201		2a. REPORT SECURITY CLASSIFICATION Unclassified	
		2b. GROUP	
3. REPORT TITLE DESIGN AND EVALUATION OF AN ENERGY DISSIPATING SPRING DEVICE (U)			
4. DESCRIPTIVE NOTES (Type of report and inclusive dates) Technical Report			
5. AUTHOR (First name, middle initial, last name) Henry P. Swieskowski			
6. REPORT DATE December 1971		7a. TOTAL NO. OF PAGES 22	7b. NO. OF REFS 0
8a. CONTRACT OR GRANT NO.		8b. ORIGINATOR'S REPORT NUMBER(S) RE-TR-71-76	
8. PROJECT NO. DA 1W562604A6U7			
c. AMS Code 5F2D.11.807		9b. OTHER REPORT NO(S) (Any other numbers that may be assigned this report)	
d.			
10. DISTRIBUTION STATEMENT Approved for public release, distribution unlimited.			
11. SUPPLEMENTARY NOTES		12. SPONSORING MILITARY ACTIVITY U. S. Army Weapons Command	
13. ABSTRACT The design and the operation of a new and efficient mechanism for energy dissipation, developed by the Research Directorate of the Weapons Laboratory at Rock Island, are described in this report. The device comprises nine components. The major components are the recoil spring and the positioning spring. To effect energy dissipation, the potential energy in the recoil spring is allowed to expand after the spring is released from a seared position. A numerical example is illustrated with prescribed parametric values for the recoil and the positioning springs. Two alternative methods are given for the computation of the amount of energy dissipation. Load deflection test results are discussed in detail. A mathematical equation is derived by which the amount of energy dissipation is expressed in terms of the load deflection rates of the recoil and the positioning springs. (U) (Swieskowski, Henry P.)			

DD FORM 1473

REPLACES DD FORM 1473, 1 JAN 64, WHICH IS OBSOLETE FOR ARMY USE.

Unclassified

Security Classification

Unclassified

Security Classification

14. KEY WORDS	LINK A		LINK B		LINK C	
	ROLE	WT	ROLE	WT	ROLE	WT
1. Energy Dissipation						
2. Shock Absorbing						
3. Springs						
4. Mechanical Device						
5. Test Results						

Unclassified

Security Classification

AD

RESEARCH DIRECTORATE  
WEAPONS LABORATORY AT ROCK ISLAND  
RESEARCH, DEVELOPMENT AND ENGINEERING DIRECTORATE

U. S. ARMY WEAPONS COMMAND

TECHNICAL REPORT

RE-TR-71-76

DESIGN AND EVALUATION OF AN ENERGY  
DISSIPATING SPRING DEVICE

Henry P. Swieskowski

December 1971

DA 1W562604A607

AMS Code 552D.11.807

Approved for public release, distribution unlimited.

## ABSTRACT

The design and the operation of a new and efficient mechanism for energy dissipation, developed by the Research Directorate of the Weapons Laboratory at Rock Island, are described in this report. The device comprises nine components. The major components are the recoil spring and the positioning spring. To effect energy dissipation, the potential energy in the recoil spring is allowed to expand after the spring is released from a seared position. A numerical example is illustrated with prescribed parametric values for the recoil and the positioning springs. Two alternative methods are given for the computation of the amount of energy dissipation. Load deflection test results are discussed in detail. A mathematical equation is derived by which the amount of energy dissipation is expressed in terms of the load deflection rates of the recoil and the positioning springs.

## CONTENTS

	<u>Page</u>
Title Page	i
Abstract	ii
Table of Contents	iii
Objective	1
Introduction	1
Discussion	1
Operation of Mechanism	1
Numerical Example	3
Design of Prototype	5
Test Results	5
Mathematical Relationship	5
Conclusions	16
Recommendations	16
Distribution	17
DD Form 1473 (Document Control Data R&D)	21

## OBJECTIVE

The objective of this project was to design, fabricate, and evaluate a new mechanical energy dissipator for buffer applications and to derive a mathematical relationship expressing the amount of energy dissipation in terms of the load deflection rates of the component springs.

## INTRODUCTION

The operation of practically all mechanical energy-dissipating spring mechanisms is based on the conversion of kinetic energy to heat through frictional forces. The device described in this report represents a new and unique method of energy dissipation. To effect energy dissipation, the potential energy in the recoil spring is allowed to expand after the spring is released from a seared position. The device can be used in applications in which ring springs or some type of frictional spring mechanism are presently used for energy dissipation.

## DISCUSSION

### Operation of Mechanism

A sectional view of the prototype is shown in Figure 1. The recoil spring is compressed by the absorption of the kinetic energy of the bolt. The rear seat of the recoil spring is held stationary by the sear, while the load on the recoil spring increases. At a predetermined deflection point, the sear is released and the recoil spring is allowed to expand and compress the positioning spring. During this phase, the recoil spring is expanding and energy is dissipated. Equilibrium is established when loads on both springs are balanced; thereafter, the two springs are functioning in series, and the small remaining portion of the energy of the bolt is absorbed. In counterrecoil, four components are returned to their original positions: both springs, the plunger, and the sear latch. The sear is forced into lock position by the sear spring, and thus the mechanism is ready for the following cycle. If the device had been designed for just one cycle of operation, the positioning spring could be eliminated from the assembly.

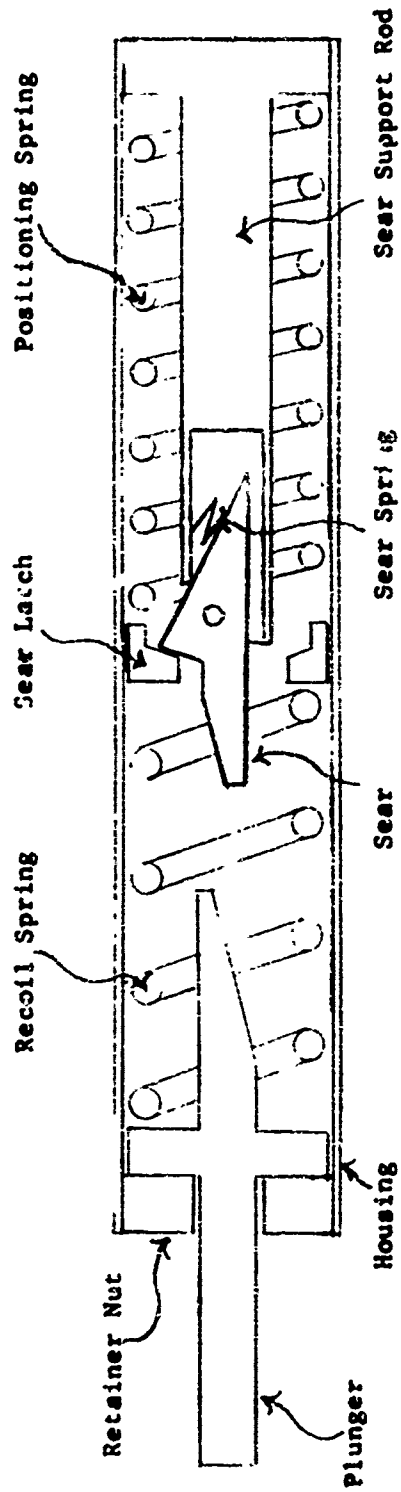

Sectional View  
Energy Dissipating Device

FIGURE 1

The initial loads on the recoil and positioning springs are equal to ensure that the sear latch is returned to its original position. However, the load deflection rates of the two springs can differ, and the amount of energy dissipation can be regulated by the proper selection of load deflection rates.

Numerical Example

Assume that the recoil and the positioning springs have the following properties:

<u>Recoil Spring</u>	<u>Positioning Spring</u>
Preload, $P = 200$ Lb.	Preload, $P' = 200$ Lb.
Load deflection rate, $R = 200$ Lb./In.	Load deflection rate, $R' = 100$ Lb./In.
Compression applied to recoil spring before sear release, $S_c = 1.00$ inch.	
Load on recoil spring at the end of compression $\bar{P}$ ,	$\bar{P} = 400$ Lb.
Expansion of recoil spring after sear release,	$S_e = 2/3$ inch.

Allow the recoil spring to be compressed a distance  $S_c$  equal to one inch before sear release. Thus, the load on the recoil spring will be increased to  $\bar{P} = 400$  Lb, and the load on the positioning spring will remain at 200 Lb. Immediately after sear release, the recoil spring will expand by a distance  $S_e$  and the loads on both springs become equal. The mathematical relationship in which this condition is described is given as follows:

$$\begin{aligned} \bar{P} - RS_e &= P' + R'S_e \\ 400 - 200 S_e &= 200 + 100 S_e, & (1) \\ \text{and } S_e &= 2/3 \text{ Inch} \end{aligned}$$

$$\text{Resultant spring load, } P_R = \bar{P} - RS_2 = 400 - 200 (2/3) = 267 \text{ Lb.}$$

Therefore, immediately after sear release, the load on the recoil spring decreases from 400 Lb to 267 Lb. The load on the positioning spring increases from 200 Lb to 267 Lb.

The amount of energy dissipation can be calculated by either of the following two methods: 1. The amount of energy absorbed by the recoil spring before spring release is discussed below:

$$\text{Energy absorbed, } E_A = \frac{(P+\bar{P})}{2} S_1 = \frac{(200+400)}{2} (1.0) = 300 \text{ In-Lb}$$

The amount of energy remaining in the mechanism immediately after sear release is given below:

$$\text{Energy remaining, } E_R = \frac{(P+\bar{P})}{2} S_2 = \frac{(200+267)}{2} (1.0) = 233 \text{ In-Lb}$$

$$\begin{aligned} \text{Amount of energy dissipation, } E_D &= E_A - E_R = \\ &300 - 233 = 67 \text{ In-Lb} \end{aligned}$$

2. The amount of energy dissipated is equal to the work performed by the recoil spring in expanding over the distance  $S_2$ , equal to 2/3 inch. The force,  $F$ , acting over this distance varies and is equal to the difference in loads between the recoil spring and the positioning spring.

$$\begin{aligned} F &= \bar{P} - RD - P' - R'D \\ &= 400 - 200D - 200 - 100D = 200 - 300D \end{aligned} \tag{2}$$

Here,  $D$  varies from 0 to 2/3 inch. Integration of the above expression yields

$$\text{Amount of energy dissipation, } E_D = \int_0^{2/3} (200 - 300D) dD = 67 \text{ In-Lb}$$

## Design of Prototype

Detail drawings of the machined components are given on Figures 2, 3, and 4. Specifications of the recoil, positioning, and sear springs are listed on Figures 5, 6, and 7. A photograph of the complete assembly is shown on Figure 8.

## Test Results

Measured load deflection characteristics of the device are shown on Figure 9. Note that both the recoil spring and the positioning spring are compressed in series arrangement during the initial .010 inch travel. The .010 inch clearance is necessary to ensure that the sear latch is positioned in front of the sear at the completion of the counterrecoil motion. After the .010 inch initial travel, the sear latch is in contact with the sear, the positioning spring is inactivated from the system, and only the recoil spring is in operation. At a deflection of .550 inch, the cam surfaces of the plunger and the sear are in contact. At this point, the load increases rapidly to release the sear. In this test, an additional load of 14 pounds is required to depress and separate the sear from the sear latch. Sear release occurs at a deflection of .640 inch, and the spring load diminishes sharply to 10 pounds. Both springs are again in series arrangement for the remaining portion of the recoil motion and throughout the counter-recoil stroke. The area between the compression curve and the extension curve represents the energy that has been dissipated. In this test, slightly more than 60 per cent of the energy stored up by the mechanism, has been withdrawn from the system.

The consistent performance of the device is illustrated in Figure 10. The results of four consecutive load-deflection tests are shown in Figure 10. Observe that the load-deflection curves practically coincide with each other. The maximum variance between the curves occurs at the point of sear release.

## Mathematical Relationship

An equation derived to express the amount of energy dissipation in terms of the load-deflection rates of the recoil and the positioning springs would be of value. This equation would aid the designer in selecting the required spring rates to properly regulate the amount of energy dissipation.

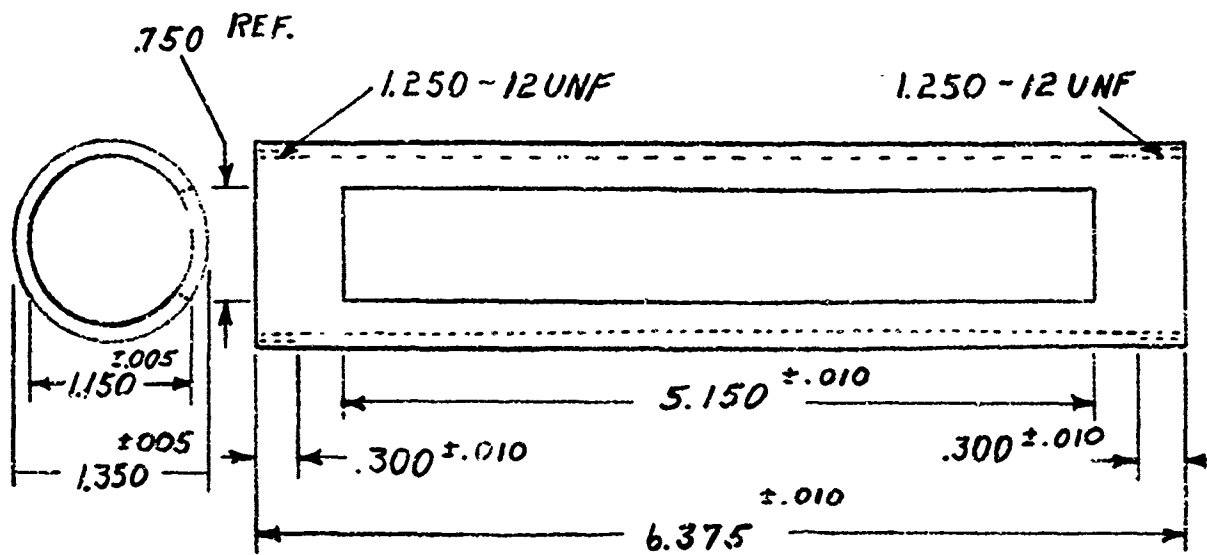

MATERIAL - QQ-S-624 4140

HOUSING

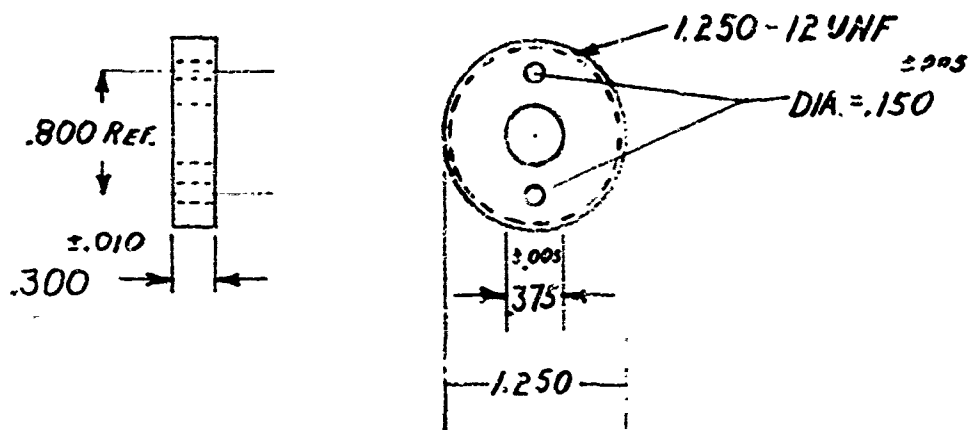

MATERIAL - QQ-S-624 4140

RETAINER NUT

FIGURE 2

TOLERANCE OF  $\pm 0.010$  APPLIES TO ALL DIMENSIONS

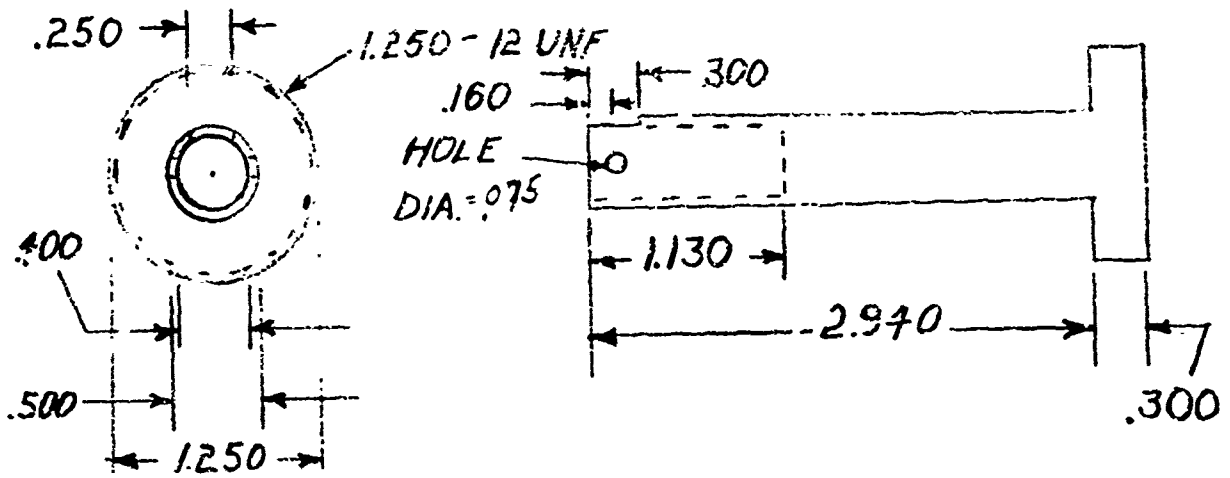

MATERIAL - QQ-S-624 4140

SEAR SUPPORT ROD

TOLERANCE OF  $\pm 0.010$  APPLIES TO ALL DIMENSIONS

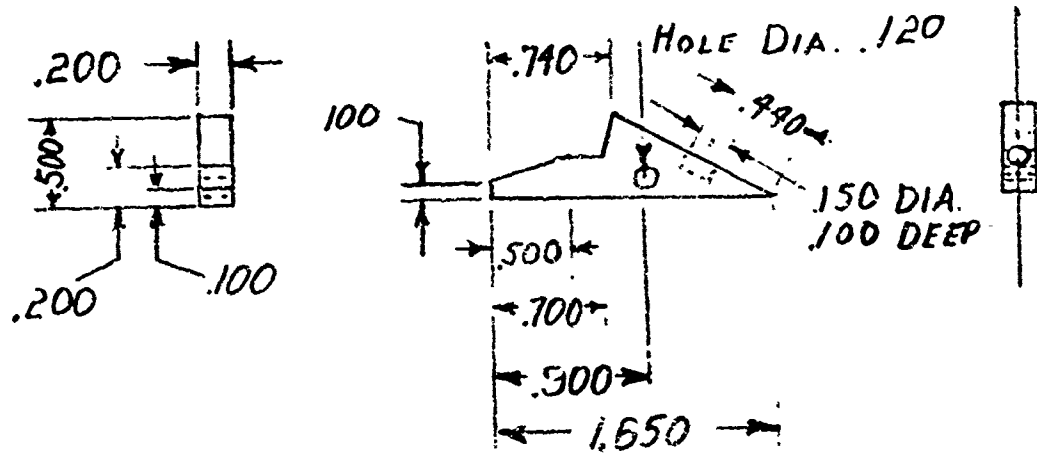

MATERIAL - QQ-S-624 4140

SEAR

FIGURE 3

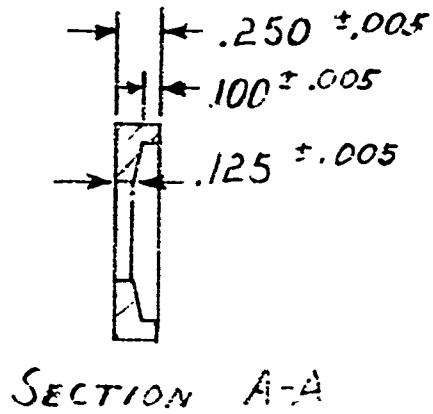
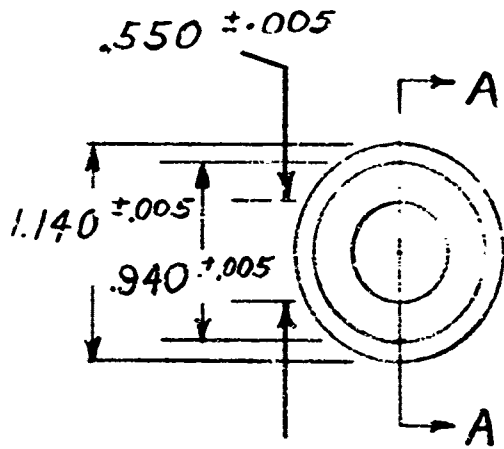

MATERIAL - QQ-S-624 4140

SEAR LATCH

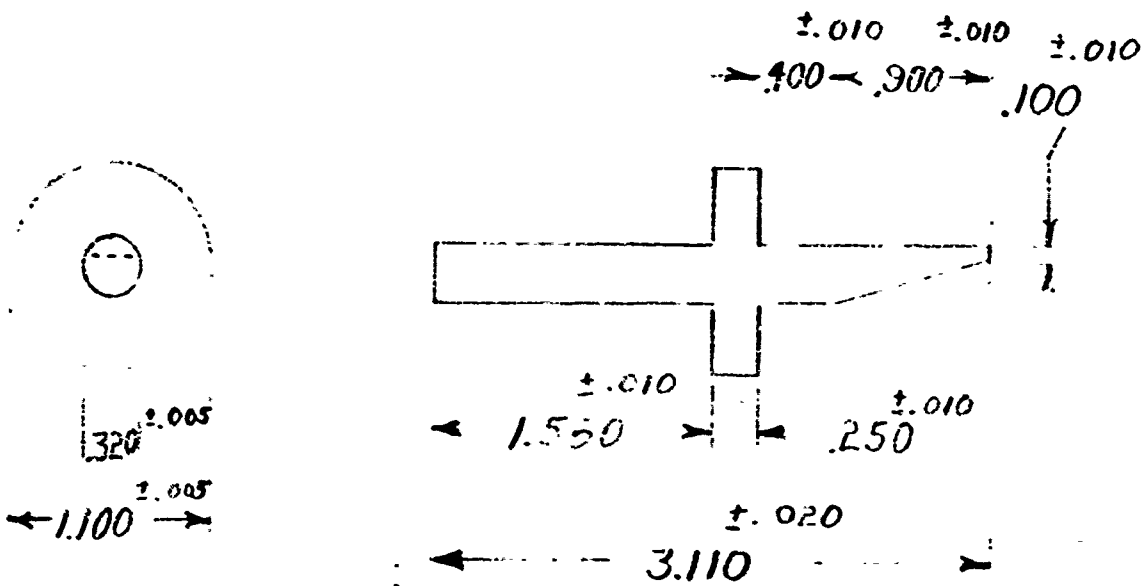

MATERIAL - QQ-S-624 4140

PLUNGER

FIGURE 4

PECOIL SPRING

WIRE SIZE (In.).....	.125
OUTSIDE DIAMETER (In.).....	1.100±.015
TOTAL COILS.....	11.0
TYPE OF ENDS.....	Closed and Ground
FREE HEIGHT, APPROX. (In.).....	2.49
MEAN ASSEMBLED HEIGHT (In.).....	2.370
LOAD AT MEAN ASSEMBLED HEIGHT (lb).....	5.0±1.0
MINIMUM OPERATING HEIGHT (In.).....	1.570
LOAD AT MINIMUM OPERATING HEIGHT (lb).....	38.6±5.0
LOAD - DEFLECTION RATE (lb/in).....	42
MAXIMUM SOLID HEIGHT (In.).....	1.450
SPRING HELIX.....	Optional

**MATERIAL:** Music Wire, QQ-W-470

**STRESS RELIEVE:** - Heat at 450° ± 25° for 30 minutes

**PRESET:** - Compress to solid height 3 times prior to gaging

FIGURE 5

POSITIONING SPRING

WIRE SIZE (In.).....	.100
OUTSIDE DIAMETER (In.).....	1.100±.015
TOTAL COILS.....	13
TYPE OF ENDS.....	Closed and Ground
FREE HEIGHT, APPROX. (In.).....	3.30
MEAN ASSEMBLED HEIGHT (In.).....	2.800
LOAD AT MEAN ASSEMBLED HEIGHT (lb).....	5.0±1.0
MINIMUM OPERATING HEIGHT (In.).....	2.154
LOAD AT MINIMUM OPERATING HEIGHT (lb).....	11.5±2.5
LOAD - DEFLECTION RATE (lb/in).....	10.0
MAXIMUM SOLID HEIGHT (In.).....	1.700
SPRING HELIX.....	Optional

**MATERIAL:** Music Wire, QQ-W-470

**STRESS RELIEVE:** - Heat at 450° ± 25° for 30 minutes

**PRESET:** - Compress in solid height 3 times prior to gaging

FIGURE 6

SEAR SPRING

WIRE SIZE (In.).....	.018
OUTSIDE DIAMETER (In.).....	.145±.003
TOTAL COILS.....	8.0
TYPE OF ENDS.....	Closed and Ground
FREE HEIGHT, APPROX. (In.).....	.38
MEAN ASSEMBLED HEIGHT (In.).....	.300
LOAD AT MEAN ASSEMBLED HEIGHT (1b).....	.6±.2
MINIMUM OPERATING HEIGHT (In.).....	.200
LOAD AT MINIMUM OPERATING HEIGHT (1b).....	1.5±.4
LOAD - DEFLECTION RATE (1b/in).....	8.2
MAXIMUM SOLID HEIGHT (In.).....	.150
SPRING HELIX.....	Optional

**MATERIAL:** Music Wire, QQ-W-47C

**STRESS RELIEVE:** - Heat at 450° ± 25° for 30 minutes

**PRESET:** - Compress to solid height 3 times prior to gaging

FIGURE 7

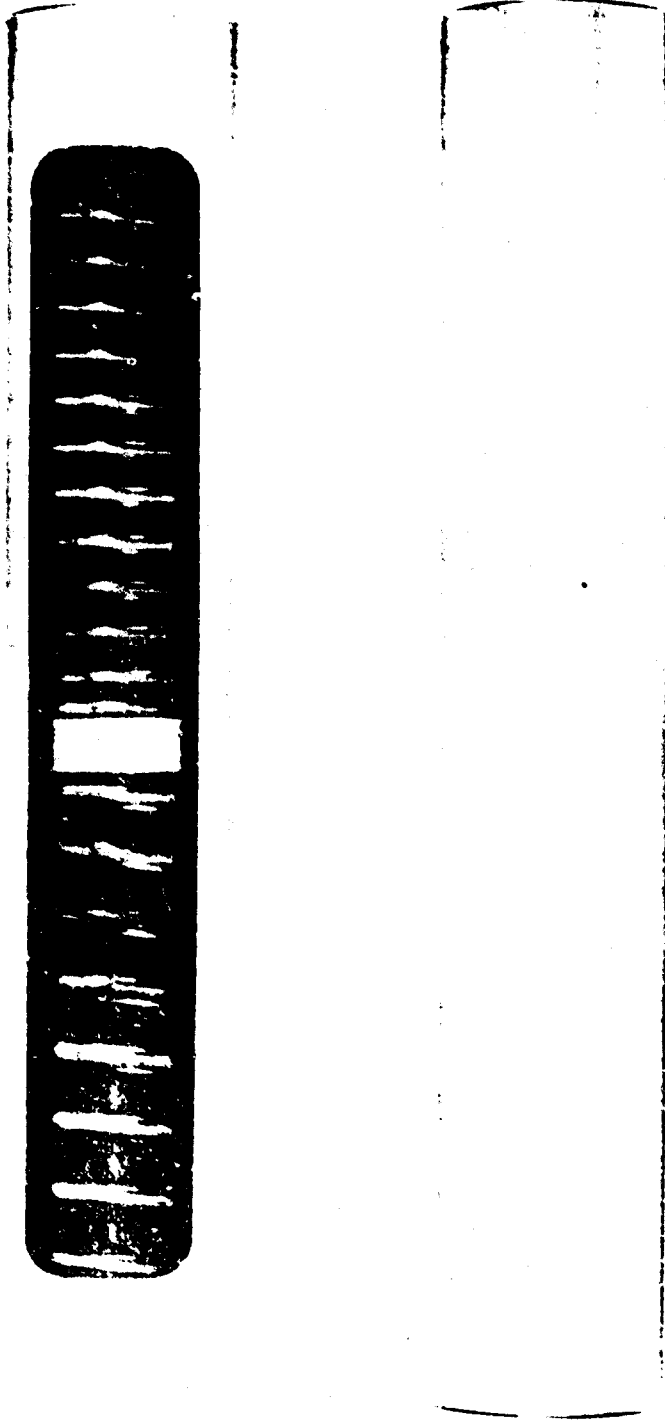

**FIGURE 8**  
**ENERGY DISSIPATING DEVICE**

**Weapons Laboratory at Rock Island, Research Directorate  
Materials Science and Technology Division 11-199-9353/AMC-70**

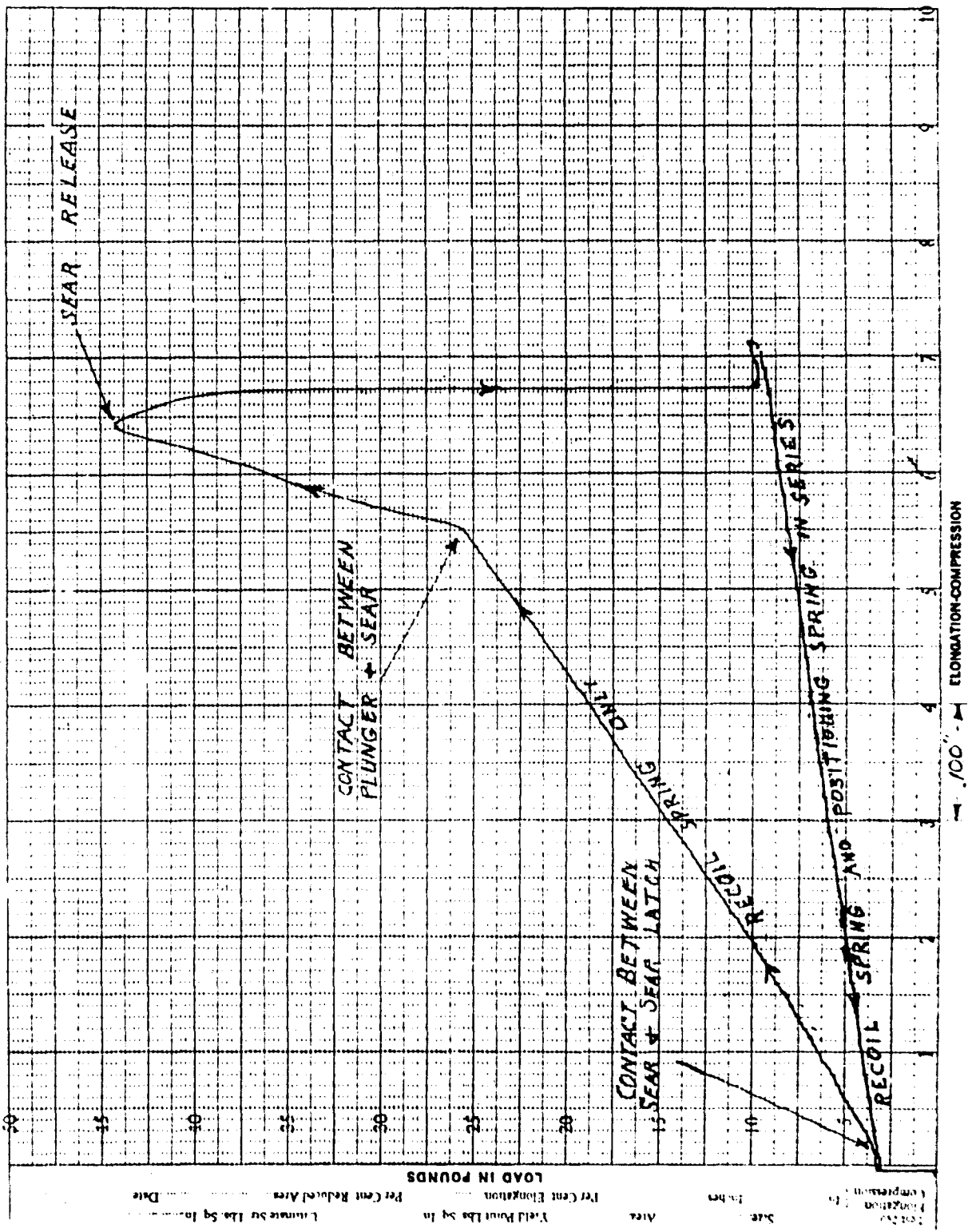
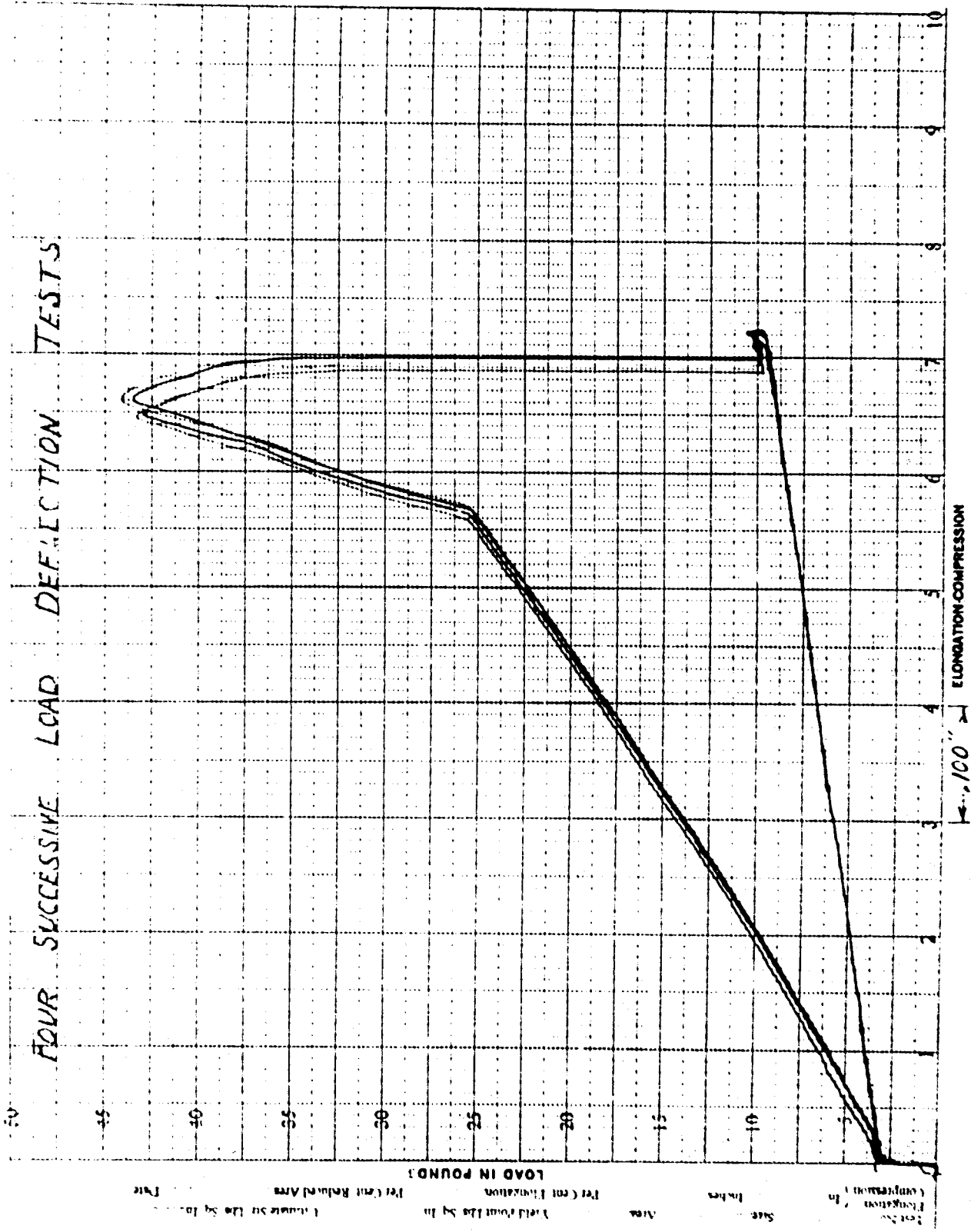

FIGURE 9

FOUR SUCCESSIVE LOAD DEFLECTION TESTS



The force on the recoil spring, immediately after sear release, decreases rapidly until it equals the force on the positioning spring. This varying force,  $F$ , is expressed by Equation 2

$$\text{The substituting of } \bar{P} = P + RS_1 \quad (3)$$

$$\text{and } P = P' \quad (4)$$

transforms Equation 2 to

$$F = RS_1 - RD - R'D \quad (5)$$

The distance  $D$  varies from 0 (at sear release) to  $S_2$  (at load equilibrium between the recoil spring and the positioning spring). The amount of energy dissipation is equal to the spring force times the distance over which the spring expands.

$$\text{Energy dissipated, } E_D = \int_0^{S_2} (RS_1 - RD - R'D) dD$$

$$E_D = RS_1 S_2 - \frac{RS_1^2}{2} - \frac{R'S_2^2}{2} \quad (6)$$

Combining Equations 1, 3, and 4 yields  $RS_1 - RS_1 - R'S$  and solving for  $S_1$  results in

$$S_1 = \frac{RS}{R+R'} \quad (7)$$

The substitution of Equation 7 into Equation 6 yields the desired expression

$$E_D = \frac{R^2 S_2^2}{2[R+R']} \quad (8)$$

An examination of Equation 8 shows that the amount of energy dissipation increases when the ratio  $R/P'$  increases

For example:

$$\text{with } \frac{R}{R_1} = 1 \quad E_D = \frac{RS_1^2}{4} = .25 RS_1^2$$

$$\frac{R}{R_1} = 2 \quad E_D = \frac{RS_1^2}{3} = .33 RS_1^2$$

$$\frac{R}{R_1} = 4 \quad E_D = \frac{2RS_1^2}{5} = .40 RS_1^2$$

### CONCLUSIONS

The energy dissipating device represents a new and efficient mechanism for the withdrawal of energy. The device should meet weapon buffer requirements, particularly in applications in which the maximum force is less than 500 pounds. Load-deflection curves taken on repeated tests practically coincide. This condition indicates the consistent performance of the device.

The amount of energy dissipation can be easily regulated by the proper selection of load-deflection rates for the recoil and the positioning springs.

### RECOMMENDATIONS

The device should be designed to meet the buffer requirements of a particular weapon system.

A dual sear arrangement should be used in applications in which the recoil force is greater than 300 pounds to attain a balanced loading condition on the sear latch.