

AEDC-TR-72-13

cy2



# EVALUATION OF THE THIOKOL TE-T-607-1 MOTOR AT SIMULATED ALTITUDE CONDITIONS

A. A. Cimino

ARO, Inc.

March 1972

Approved for public release; distribution unlimited.

**ENGINE TEST FACILITY  
ARNOLD ENGINEERING DEVELOPMENT CENTER  
AIR FORCE SYSTEMS COMMAND  
ARNOLD AIR FORCE STATION, TENNESSEE**

PROPERTY OF U S AIR FORCE  
AEDC LIBRARY  
F40600-72-C-0003

# ***NOTICES***

When U. S. Government drawings specifications, or other data are used for any purpose other than a definitely related Government procurement operation, the Government thereby incurs no responsibility nor any obligation whatsoever, and the fact that the Government may have formulated, furnished, or in any way supplied the said drawings, specifications, or other data, is not to be regarded by implication or otherwise, or in any manner licensing the holder or any other person or corporation, or conveying any rights or permission to manufacture, use, or sell any patented invention that may in any way be related thereto.

Qualified users may obtain copies of this report from the Defense Documentation Center.

References to named commercial products in this report are not to be considered in any sense as an endorsement of the product by the United States Air Force or the Government.

**EVALUATION OF THE THIOKOL TE-T-607-1 MOTOR  
AT SIMULATED ALTITUDE CONDITIONS**

**A. A. Cimino  
ARO, Inc.**

**Approved for public release; distribution unlimited.**

## FOREWORD

The test program reported herein was conducted under the sponsorship of the National Aeronautics and Space Administration (NASA), Jet Propulsion Laboratory (JPL) under Program Element 921E4.

The results of the test were obtained by ARO, Inc. (a subsidiary of Sverdrup & Parcel and Associates, Inc.), contract operator of the Arnold Engineering Development Center (AEDC), Air Force Systems Command (AFSC), Arnold Air Force Station, Tennessee, under Contract F40600-72-C-0003. The test was conducted in Propulsion Development Test Cell (T-3) of the Engine Test Facility (ETF) on August 27, 1971, under ARO Project Number RC1261, and the manuscript was submitted for publication on November 30, 1971.

This technical report has been reviewed and is approved.

Joseph H. Hagan  
Lt Colonel, USAF  
AF Representative, ETF  
Directorate of Test

Duncan W. Rabey, Jr.  
Colonel, USAF  
Director of Test

**ABSTRACT**

One Thiokol Chemical Corporation TE-T-607-1 solid-propellant rocket motor was successfully fired at an average simulated altitude of 98,000 ft. The program objectives were to determine vacuum ballistic performance after temperature conditioning at 70°F, to determine altitude ignition characteristics, to evaluate motor structural integrity, and to determine motor temperature-time history at selected critical locations during and after motor operation.

## CONTENTS

	<u>Page</u>
ABSTRACT . . . . .	iii
NOMENCLATURE . . . . .	v
I. INTRODUCTION . . . . .	1
II. APPARATUS . . . . .	1
III. PROCEDURE . . . . .	4
IV. RESULTS AND DISCUSSION . . . . .	4
V. SUMMARY OF RESULTS . . . . .	6
REFERENCES . . . . .	7

## APPENDIXES

### I. ILLUSTRATIONS

#### Figure

1. Thiokol Chemical Corporation TE-T-607-1 Solid-Propellant Rocket Motor . . . . .	11
2. Installation of the Thiokol TE-T-607-1 Rocket Motor in Propulsion Development Test Cell (T-3) . . . . .	14
3. Thermocouple Locations on the Thiokol TE-T-607-1 Rocket Motor . . . . .	16
4. Variation of Thrust, Chamber Pressure, and Cell Pressure during Motor Ignition . . . . .	17
5. Variation of Thrust, Chamber Pressure, and Cell Pressure during Motor Burn Time . . . . .	18
6. Schematic of Chamber and Cell Pressure-Time Variation Defining Characteristic Events . . . . .	19
7. Postfire Photographs of Motor Assembly . . . . .	20
8. Motor Temperature Variation with Time . . . . .	21

### II. TABLES

I. Instrumentation Summary and Measurement Uncertainty . . . . .	25
II. Summary of the TE-T-607-1 Motor Performance . . . . .	26
III. Summary of the TE-T-607-1 Motor Physical Dimensions . . . . .	27

## NOMENCLATURE

$A_{ex}$	Nozzle exit area, in. <sup>2</sup>
$A_t$	Nozzle throat area, in. <sup>2</sup>
$C_F$	Average vacuum thrust coefficient, based on total burn time ( $t_s$ ) and the average of prefire and postfire nozzle throat area
$c_f$	Vacuum thrust coefficient over a selected 10-sec interval of motor operation just prior to tailoff

F	Measured axial thrust, lbf
$I_{vac}$	Vacuum impulse based on total burn time ( $t_s$ ), lbf-sec
$P_{cell}$	Measured cell pressure, psia
$P_{ch}$	Measured motor chamber pressure, psia
TC	Thermocouple on the motor case
TI	Thermocouple on the igniter case
TN	Thermocouple on the nozzle
$t_a$	Action time, time interval from 10 percent of maximum chamber pressure at ignition to 10 percent of maximum chamber pressure at tailoff, sec
$t_{bd}$	Time of nozzle flow breakdown, sec
$t_l$	Time interval from the application of voltage to the igniter to the first indication of chamber pressure, sec
$t_o$	Zero time, time of application of ignition voltage
$t_s$	Total burn time, time interval between the application of ignition voltage and the time at which the ratio of chamber-to-cell pressure has decreased to 1.3 during tailoff, sec

## SECTION I INTRODUCTION

The Thiokol Chemical Corporation (TCC) TE-T-607-1 solid-propellant rocket motor was designed to demonstrate new technology for low-pressure, low-thrust, solid-propellant rocket motors (Ref. 1). The motor tested used a previously fired, refurbished TE-M-521 motor case with an 80:1 area ratio nozzle. The end burning propellant grain is considered to be one-half scale of that suitable for a typical Jupiter Orbiter Spacecraft Mission (Ref. 1).

The primary objectives of the test program reported herein were to determine motor vacuum ballistic performance (after temperature conditioning at 70°F) and altitude ignition characteristics, to evaluate motor structural integrity, and to determine motor temperature-time history at selected critical locations during and after motor operation.

Motor altitude ballistic performance, ignition characteristics, motor structural integrity, and motor temperature-time history are discussed.

## SECTION II APPARATUS

### 2.1 TEST ARTICLE

The Thiokol Chemical Corporation TE-T-607-1, solid-propellant rocket motor (Fig. 1, Appendix I) utilizes a TE-M-521 motor case with an all carbon "hot nozzle" design. Nominal dimensions and performance characteristics at 70°F are:

Length, in.	40.8
Diameter, in.	17.44
Loaded Weight, lbm	300
Propellant Weight, lbm	240
Maximum Thrust, lbf	800
Maximum Chamber Pressure, psia	220
Burn Time, sec	150
Throat Area, in. <sup>2</sup>	1.65
Nozzle Area Ratio, $A_{ex}/A_t$	80

The motor case is constructed of 0.033-in.-thick forward and aft domes and a 0.061-in.-thick cylindrical section. The case material is titanium (6 AL-4V).

The case is lined internally with bonded layers of Insulcork<sup>®</sup> 2755 (granulated cork with phenolic binder) and Gen-GARD<sup>®</sup> 4030, a silica-asbestos-filled, ethylene propylene terpolymer rubber. A propellant stress relief boot is contained in the aft end of the motor (Fig. 1a).

The nozzle inlet section and exit cone (Fig. 1a) are Pyrocarb<sup>®</sup> 406. The graphite throat section is Graph-I-Tite<sup>®</sup> G-90. The Pyrocarb nozzle inlet section is bonded and

pinned to the carbon cloth phenolic aft-closure insulation. Medium lamp threads and epoxy bonding are used to attach the exit cone to the aft-closure insulation. An expansion slot, filled with a soft neoprene washer, is provided aft of the graphite throat so that the graphite throat itself is left unbonded and free to expand during motor operation.

The nozzle is externally insulated with a low density (4.3 lb/ft<sup>3</sup>) carbon felt material. The felt thickness varies from 0.4 in. (2 layers) near the aft closure exit cone attachment interface to 0.20 in. (one layer) at a location approximately 6.2 in. aft of the throat and extends to the nozzle exit plane. To provide an 80:1 expansion ratio with minimum length, the nozzle design utilized an overturned bell (circular arc) exit contour and a hyperbolic spiral inlet contour. The principal expansion contour parameters are as follows:

Initial Expansion Angle ( $\alpha$ ), deg	30
Exit Divergence Angle ( $\beta$ ), deg	10

The TE-T-607-1 rocket motor contains a composite propellant grain formulation, designated TP-H-3274A (ICC Class B) cast in an end-burning configuration. The propellant is formulated by 16-percent aluminum with an epoxy-cured, carboxyl-terminated polybutadiene (CTPB) binder.

Ignition was accomplished by one TE-P-590-1 pyrogen igniter (Fig. 1) which contains 6 BKNO<sub>3</sub> pellets (size 2D) and 2 strips (1/8 in. by 1/4 in. by 3/4 in.) of TP-H-3274A propellant used to initiate the TP-H-3274A propellant igniter grain. The igniter contained one Hi-shear PC-37 (1 amp-1 watt no fire) squib with a nominal ignition current of 5.0 amps.

## 2.2 INSTALLATION

The motor assembly was cantilever mounted from the spindle face of a spin-fixture assembly in Propulsion Development Test Cell (T-3). The spin fixture was locked in fixed position for this nonspin test. The spin assembly was mounted on a thrust cradle, which was supported from the cradle support stand by three vertical and two horizontal double-flexure columns (Fig. 2). Axial thrust was transmitted through the spindle-thrust bearing assembly to two double-bridge load cells which were flexure mounted just forward of the thrust bearing on the motor axial centerline.

Preignition pressure altitude conditions were maintained in the test cell by a steam ejector operating in series with the ETF exhaust gas compressors. During motor firing, the motor exhaust gases were used as the driving gas for the 16-in.-diam ejector-diffuser system to maintain test cell pressure at an acceptable level.

## 2.3 INSTRUMENTATION

Instrumentation was provided to measure axial force, motor chamber pressure, test cell pressure, motor case temperatures, and nozzle temperatures. Table I (Appendix II) presents instrument ranges, recording methods, and measurement uncertainty for all reported parameters.

The axial force measuring system consisted of two double-bridge, strain-gage-type load-cells mounted in the axial double-flexure column forward of the thrust bearing on the motor centerline.

Unbonded strain-gage-type transducers were used to measure test cell pressure. Bonded strain-gage-type transducers with ranges from 0 to 50, 0 to 100, and 0 to 300 psi were used to measure motor chamber pressure. Bonded strain-gage-type transducers with ranges from 0 to 1000 psi were used to measure pyrogen pressure. Chromel<sup>®</sup>-Alumel<sup>®</sup> (CA) thermocouples were bonded to the motor case, the igniter case, and on the external nozzle insulation to measure surface temperatures during and after motor burn time. Thermocouple locations are presented in Fig. 3.

The output signal of each measuring device was recorded on independent instrumentation channels. Primary data were obtained from four axial thrust channels, four test cell pressure channels, and four motor chamber pressure channels. These data were recorded as follows: Each instrument output signal was indicated in totalized digital form on a visual readout of a millivolt-to-frequency converter. A magnetic tape system, recording in frequency form stored the signal from the converter for reduction at a later time by an electronic computer. The computer provided a tabulation of average absolute values for each 0.050-sec time increment during the first 25 sec after ignition, for each 0.10-sec thereafter, and total integrals over the cumulative time increments.

The millivolt outputs of the thermocouples were recorded on magnetic tape from a multi-input, analog-to-digital converter at a sampling rate for each thermocouple of 2 samples per second for the first 150 sec and at 30-sec intervals out to 800 sec.

A recording oscillograph was used to provide an independent backup of all operating instrumentation channels except the temperature systems. Selected channels of thrust and pressure were recorded on null-balance, potentiometer-type strip charts for analysis immediately after motor firing. Visual observation of the firing was provided by a closed-circuit television monitor. High-speed, motion-picture cameras provided a permanent visual record of the firing.

## 2.4 CALIBRATION

The thrust system calibrator weights, thrust load cells, and pressure transducers were laboratory calibrated prior to usage in this test. After installation of the measuring devices in the test cell, the thrust load cells were again calibrated at sea-level, ambient conditions and also at simulated altitude.

The pressure recording systems were calibrated by an electrical, four-step calibration, using a resistance in the transducer circuits to simulate selected pressure levels. The axial thrust instrumentation systems were calibrated by applying to the thrust cradle known forces, which were produced by deadweights acting through a bellcrank. The calibrator is hydraulically actuated and remotely operated from the control room. Thermocouple recording instruments were calibrated by using known millivolt levels to simulate thermocouple outputs. After the motor firing, with the test cell at simulated altitude pressure, the recording systems were recalibrated to determine any shift.

### SECTION III PROCEDURE

The TCC TE-T-607-1 motor arrived at the AEDC on August 13, 1971. The motor was visually inspected for possible shipping damage and radiographically inspected for grain cracks, voids, or separation and found to meet criteria provided by the manufacturer.

After radiographic inspection, the motor was stored in a temperature-conditioned area. Electrical resistance of the igniter squib was measured to ensure circuit continuity. The motor assembly was weighed, and the nozzle throat and exit diameters were measured.

The motor was temperature conditioned in an environment of  $70 \pm 5^\circ\text{F}$  for a minimum period of 24 hr prior to installation in the test cell. After the motor assembly was installed in the test cell, instrumentation connections were made, and a continuity check of all electrical systems was performed. Prefire, sea-level calibrations were completed, the test cell pressure was reduced to the desired simulated altitude condition, the altitude calibrations were completed, and the motor was fired.

The test cell temperature was maintained at  $70 \pm 5^\circ\text{F}$  from the time of motor installation until the time that cell pressure was reduced to the desired simulated altitude condition. The time that the motor was out of conditioning during the installation process was 30 min.

Immediately after firing, postfire calibrations were obtained, and the test cell pressure was returned to ambient pressure conditions. The motor was then inspected, photographed, and removed to the storage area. Postfiring inspection consisted of weighing the motor assembly, measuring the nozzle exit and throat diameters, and photographically recording the postfire condition.

### SECTION IV RESULTS AND DISCUSSION

One Thiokol Chemical Corporation TE-T-607-1 solid-propellant rocket motor was successfully fired in Propulsion Development Test Cell (T-3). The motor was temperature conditioned at  $70 \pm 5^\circ\text{F}$  for a period in excess of 24 hr and fired at an average pressure altitude of about 98,000 ft. The primary objectives of the test program were to determine vacuum ballistic performance after temperature conditioning at  $70^\circ\text{F}$ , to determine altitude ignition, to evaluate motor structural integrity, and to determine motor temperature-time history at selected critical locations during and after motor operation. The resulting data are presented in both tabular and graphical form.

Motor performance data are summarized in Table II, and motor physical dimensions are summarized in Table III. Altitude ignition characteristics, ballistic performance, structural integrity, and temperature-time histories of the motor case and nozzle are presented and discussed. When multiple channels of equal accuracy instrumentation data were used to obtain values of a single parameter, the average values were used to calculate the data presented.

## 4.1 ALTITUDE IGNITION CHARACTERISTICS

The motor was ignited at a pressure altitude of 116,000 ft. The variations of thrust, chamber pressure, and cell pressure during ignition are presented in Fig. 4. The motor did not utilize a throat closure; therefore, prefire chamber pressure was equal to cell pressure (0.073 psia). Ignition lag time ( $t_q$ ) was 0.003 sec.

## 4.2 ALTITUDE BALLISTIC PERFORMANCE

The variations of thrust, chamber pressure, and test cell pressure with motor burn time are presented in Fig. 5.

The 80:1 area ratio exhaust nozzle operated fully expanded at the nozzle exit static pressure to test cell pressure ratios encountered during the firing until the start of motor tailoff burning ( $t_{bd}$ ) at 139.4 sec (Ref. 2). Since the nozzle did not operate fully expanded after 139.4 sec, the measured total impulse from 139.4 sec to the end of motor total burn time ( $t_s$ , 154.5 sec) cannot be corrected to vacuum conditions by adding the product of cell pressure integral and nozzle exit area. Therefore, total burn time ( $t_s$ ) was segmented, and the method used to determine vacuum impulse is illustrated in Fig. 6. The exhaust nozzle flow breakdown was considered to have occurred simultaneously with the exhaust diffuser flow breakdown (as indicated by a rapid increase in cell pressure during tailoff). After this time, the flow at the nozzle throat was considered to be at sonic velocity until the time ( $t_s$ ) at which the ratio of motor chamber-to-cell pressure had decreased to a value of 1.3.

The vacuum total impulse, based on total burn time ( $t_s$ ) of 154.50 sec, was 66,740 lbf-sec. Vacuum specific impulse, based on  $t_s$  and the manufacturer's stated propellant weight, was 278.60 lbf-sec/lbm. Vacuum specific impulse, based on  $t_s$  and the expended mass, was 271.40 lbf-sec/lbm.

## 4.3 STRUCTURAL INTEGRITY

Postfire photographs of the motor case and nozzle are presented in Fig. 7. Pre- and postfire inspection data revealed an increase in throat area of approximately 17.68 percent during the firing. The increase in nozzle exit area was approximately 0.12 percent during the firing.

During the postfire inspection, it was found that the nozzle assembly could be rotated while the aft closure remained stationary, indicating that the adhesive bond line shown in Fig. 1c was no longer providing structural support. The remainder of the motor appeared to be in excellent physical condition. The nozzle/aft closure assembly was not disassembled from the case.

## 4.4 MOTOR TEMPERATURE HISTORY

Motor case and nozzle temperature variations with time are presented in Fig. 8. The maximum measured case temperature was 674°F and occurred approximately 534 sec after

motor ignition as indicated by TC-6, located on the nozzle aft closure (Fig. 8d). The maximum measured nozzle external temperature was 1800°F and occurred at approximately 112 sec after ignition as indicated by thermocouple TN-3 (see Fig. 8a).

## SECTION V SUMMARY OF RESULTS

One Thiokol Chemical Corporation TE-T-607-1 solid-propellant rocket motor was successfully fired at an average pressure altitude of 98,000 ft. The motor was conditioned in a controlled environment of  $70 \pm 5^\circ\text{F}$  for a period in excess of 24 hr prior to firing. The results are summarized as follows:

1. The time interval from the time at which the firing voltage was applied to the igniter circuit to the time of increase in chamber pressure was 0.003 sec.
2. The time interval from application of ignition current to the igniter to the time at which the ratio of chamber-to-cell pressure has decreased to 1.3 at tailoff ( $t_s$ ) was 154.5 sec.
3. Vacuum total impulse, based on the time interval from the application of ignition current to the igniter to the time at which the ratio of chamber-to-cell pressure has decreased to 1.3 at tailoff, was 66,740 lbf-sec. The vacuum specific impulse, based on vacuum total impulse and the manufacturer's stated propellant weight, was 278.60 lbf-sec/lbm.
4. The nozzle throat area of the motor increased approximately 17.6 percent from the prefire area during the firing, whereas the nozzle exit area exhibited a 0.12 percent area increase.
5. Motor case and nozzle postfire inspection did not reveal any distortion or damage. The adhesive band line in the nozzle throat area did not provide structural support after motor operation and heat soak.
6. The maximum measured motor case temperature was 674°F and occurred at the nozzle aft closure at approximately 534 sec after motor ignition. The maximum measured nozzle external temperature was 1800°F and occurred approximately 112 sec after ignition.

## REFERENCES

1. Brooks, C. B., Carson, D. C., and Vriesen, C. W. "Technology Development for Low-Pressure, Low-Thrust Solid Propellant Rocket Motors." Joint Army, Navy, and Air Force (JANNAF) Combined Propulsion Meeting, 1971.
2. Summerfield, M., Foster, C. R., and Swan, W. C. "Flow Separation in Overexpanded Supersonic Exhaust Nozzles." Jet Propulsion Vol. 24, 1954, pp. 319-321.

**APPENDIXES**  
**I. ILLUSTRATIONS**  
**II. TABLES**

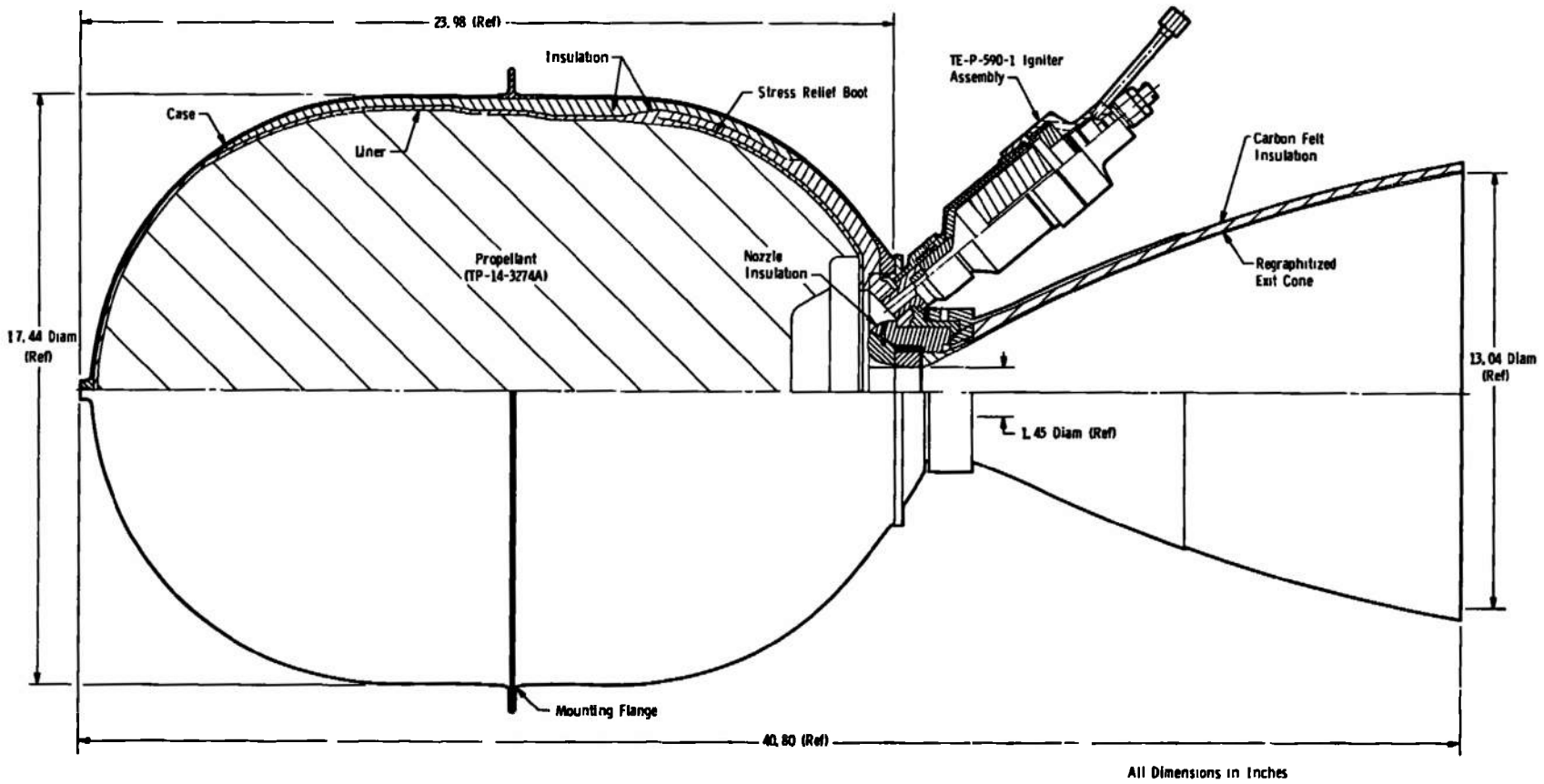

a. Schematic  
Fig. 1 Thiokol Chemical Corporation TE-T-607-1 Solid-Propellant Rocket Motor

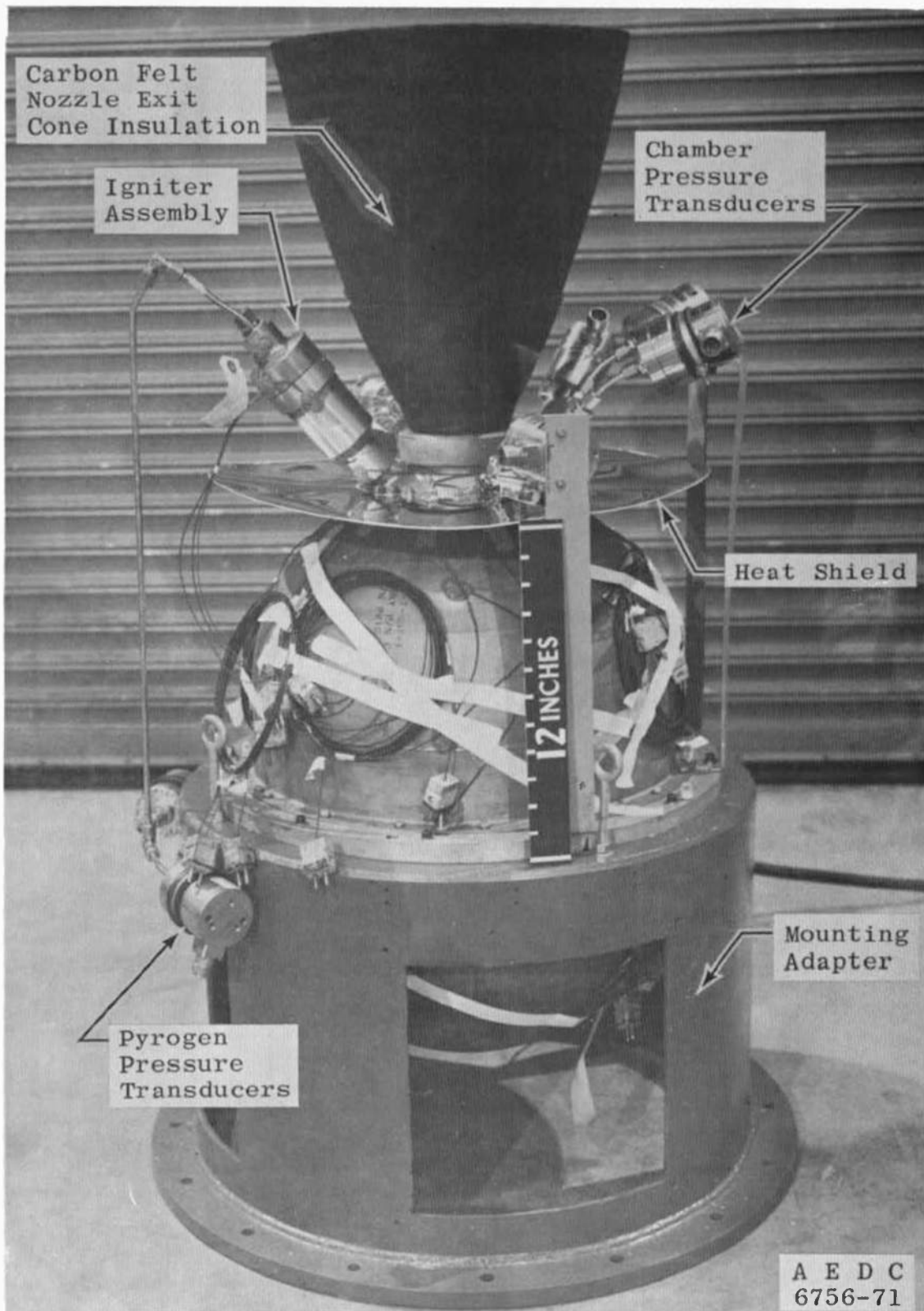

b. Photograph  
Fig. 1 Continued

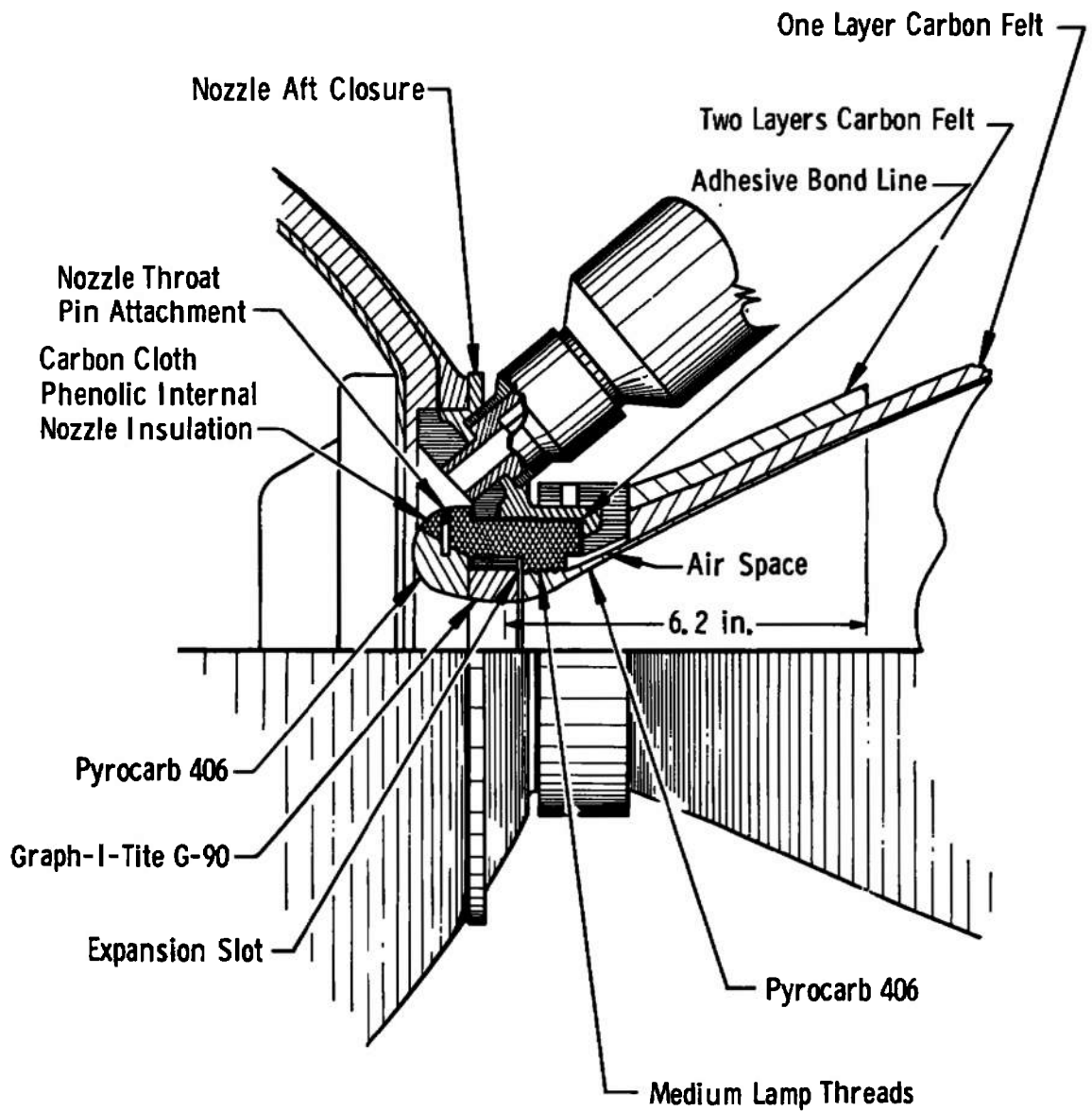

c. Nozzle Throat Detail Schematic  
 Fig. 1 Concluded

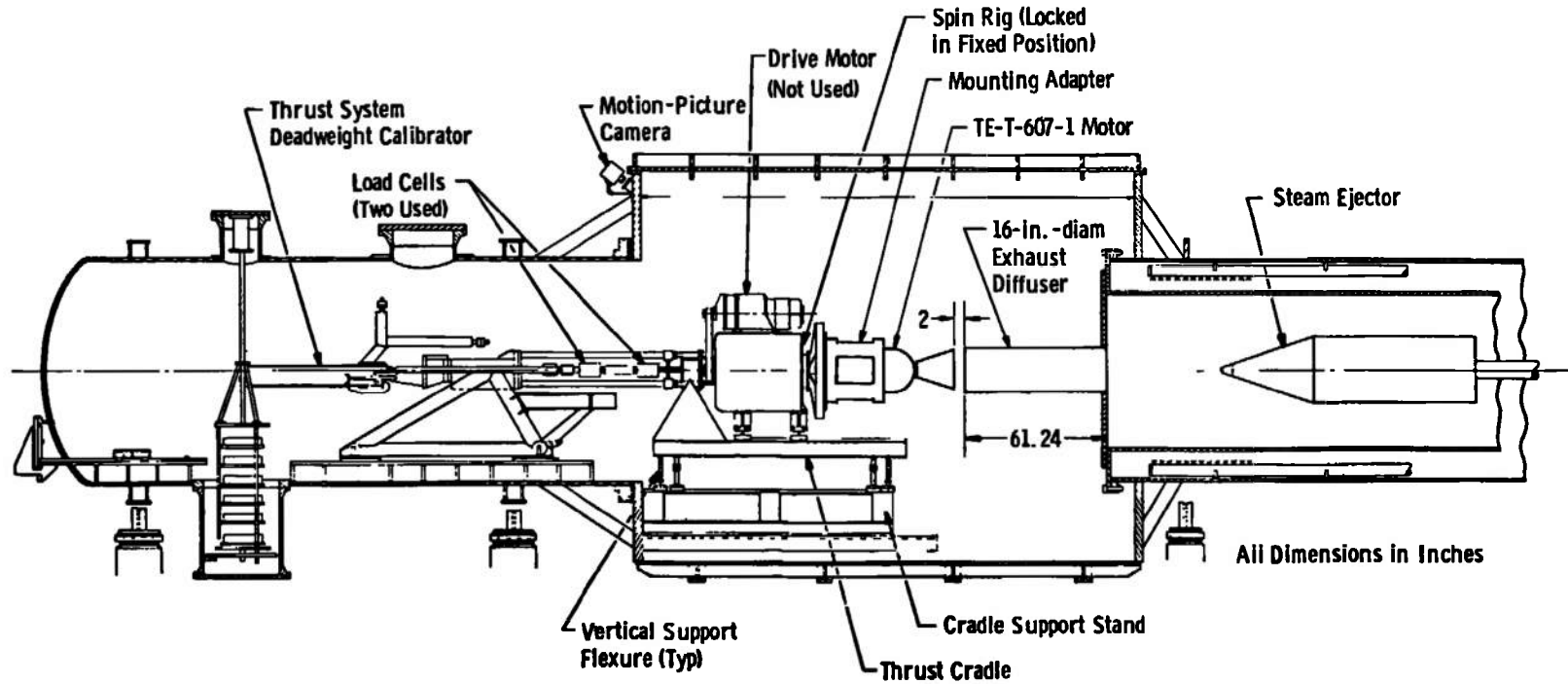

a. Schematic

Fig. 2 Installation of the Thiokol TE-T-607-1 Rocket Motor in Propulsion Development Test Cell (T-3)

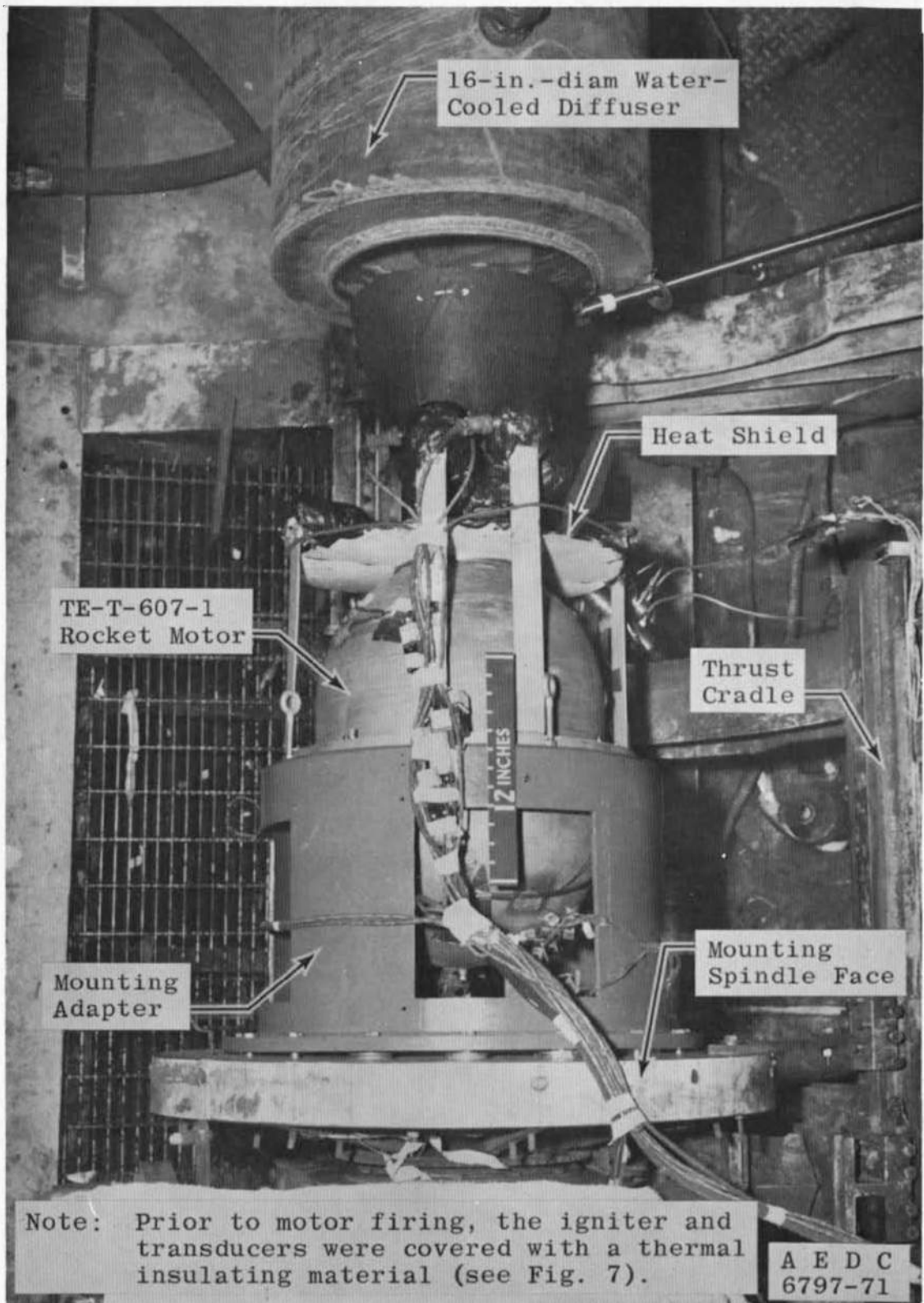

b. Photograph  
Fig. 2 Concluded



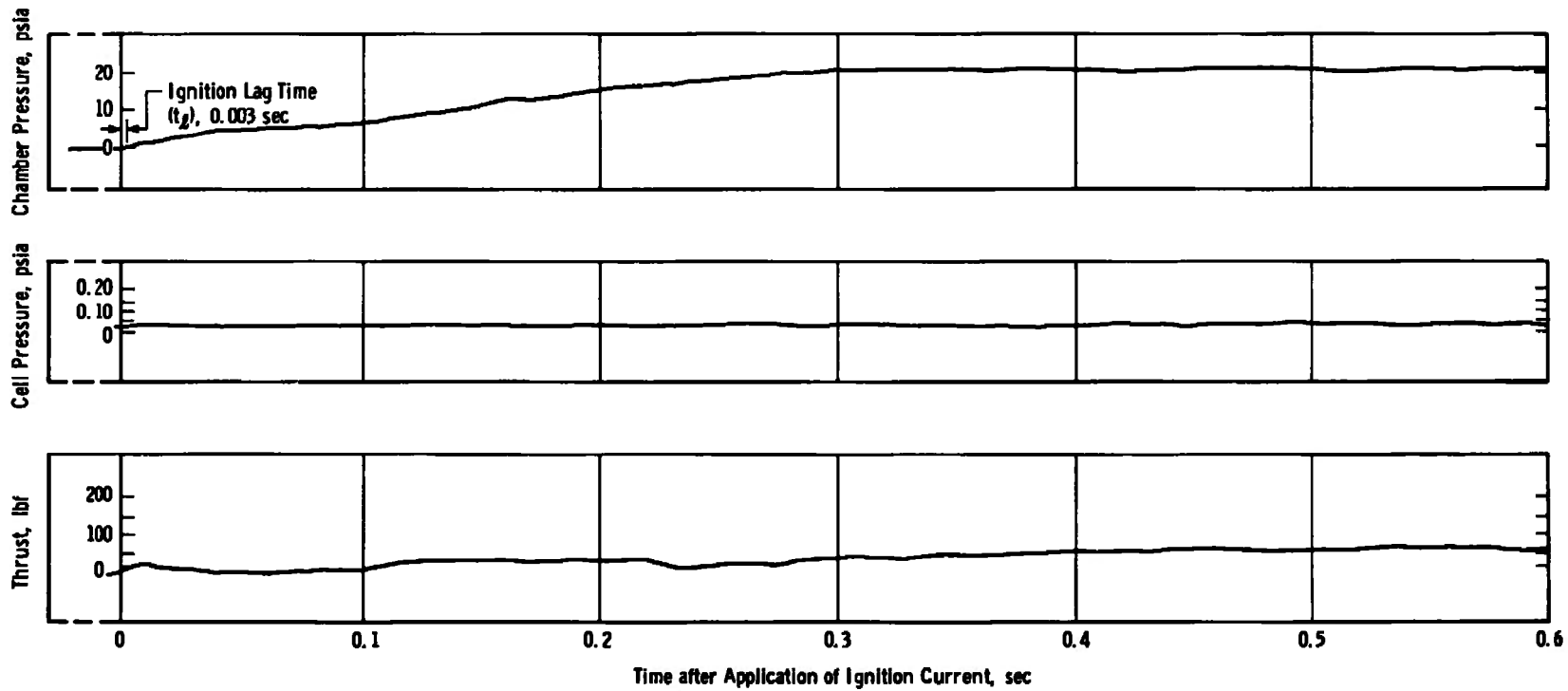

Fig. 4 Variation of Thrust, Chamber Pressure, and Cell Pressure during Motor Ignition

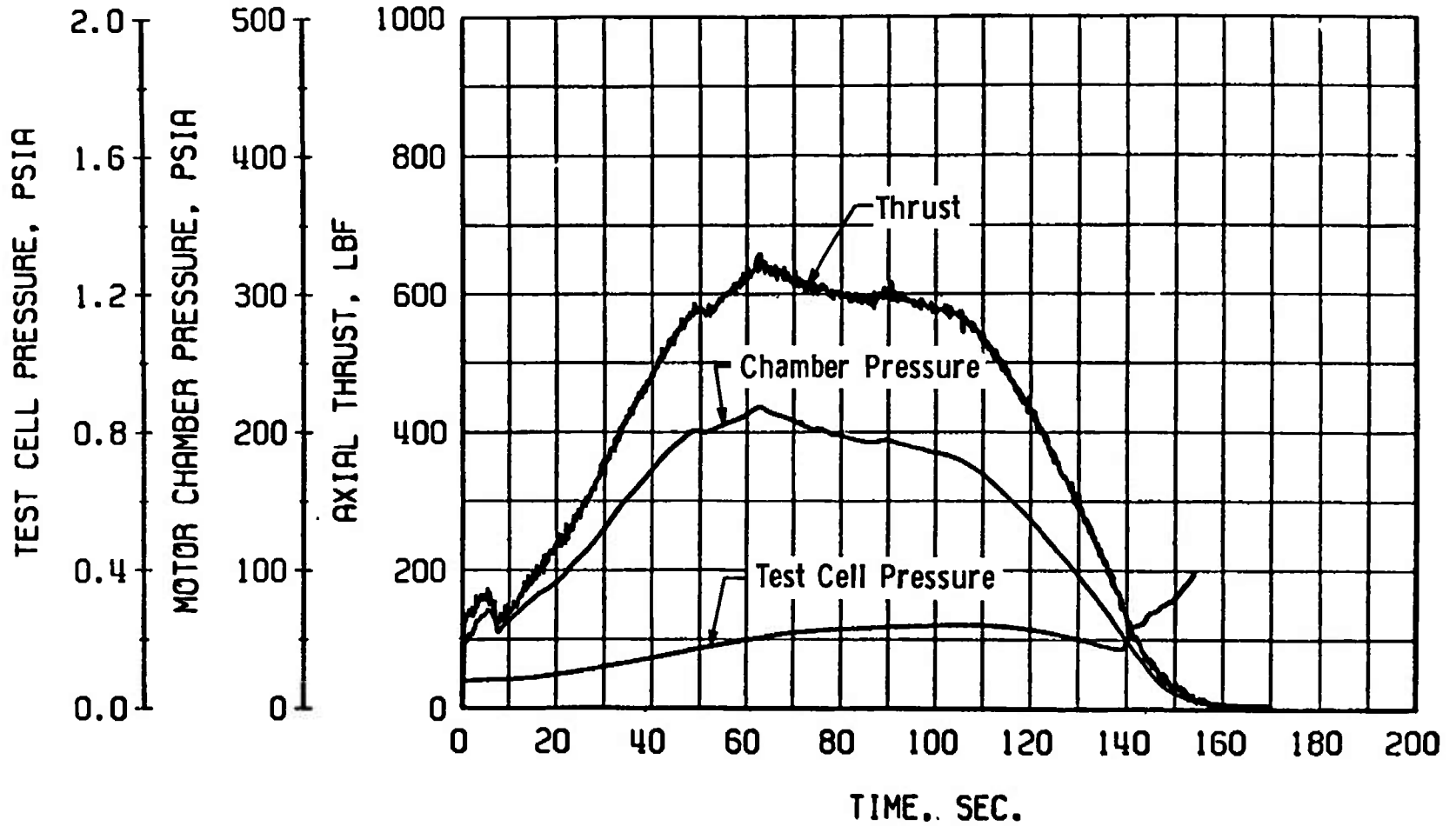
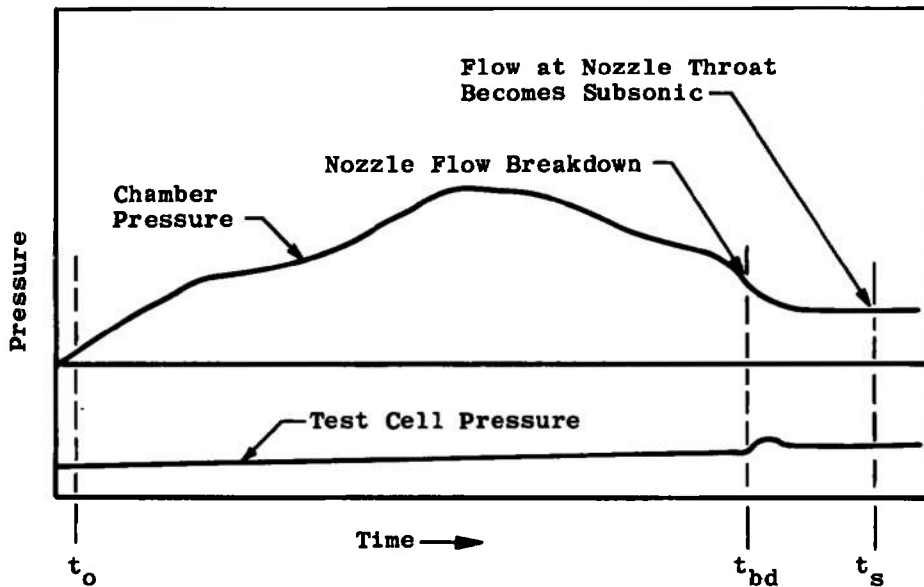

Fig. 5 Variation of Thrust, Chamber Pressure, and Cell Pressure during Motor Burn Time



$$I_{vac} = \int_{t_0}^{t_{bd}} F dt + A_{ex_{avg}} \int_{t_0}^{t_{bd}} P_{cell} dt + c_f \cdot A_{t_{post}} \int_{t_{bd}}^{t_s} P_{ch} dt$$

$$\int_{t_0}^{t_{bd}} F dt = 62,313 \text{ lbf-sec}$$

$$\int_{t_0}^{t_{bd}} P_{cell} dt = 25.52 \text{ psia-sec}$$

$$\int_{t_{bd}}^{t_s} P_{ch} dt = 320 \text{ psia-sec}$$

$$c_f = \frac{\int_{t_1}^{t_2} F dt}{A_{t_{post}} \int_{t_1}^{t_2} P_{ch} dt}, \text{ where } t_1 = 120 \text{ sec}$$

$$t_2 = 130 \text{ sec}$$

$$c_f = 1.65$$

$$A_{t_{post}} = 1.94 \text{ in.}^2 \qquad A_{ex_{avg}} = 133.85 \text{ in.}^2$$

Fig. 6 Schematic of Chamber and Cell Pressure-Time Variation Defining Characteristic Events

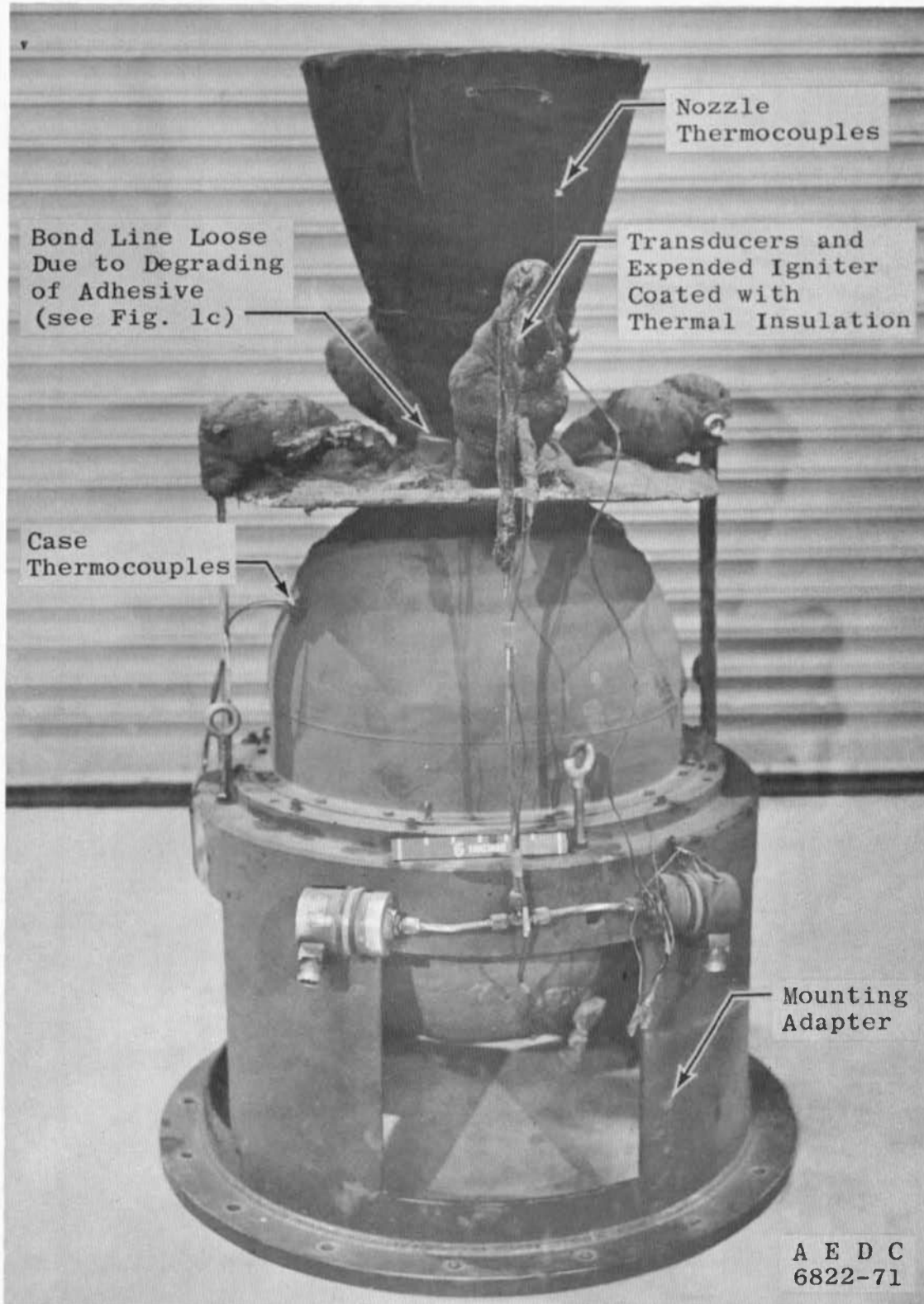
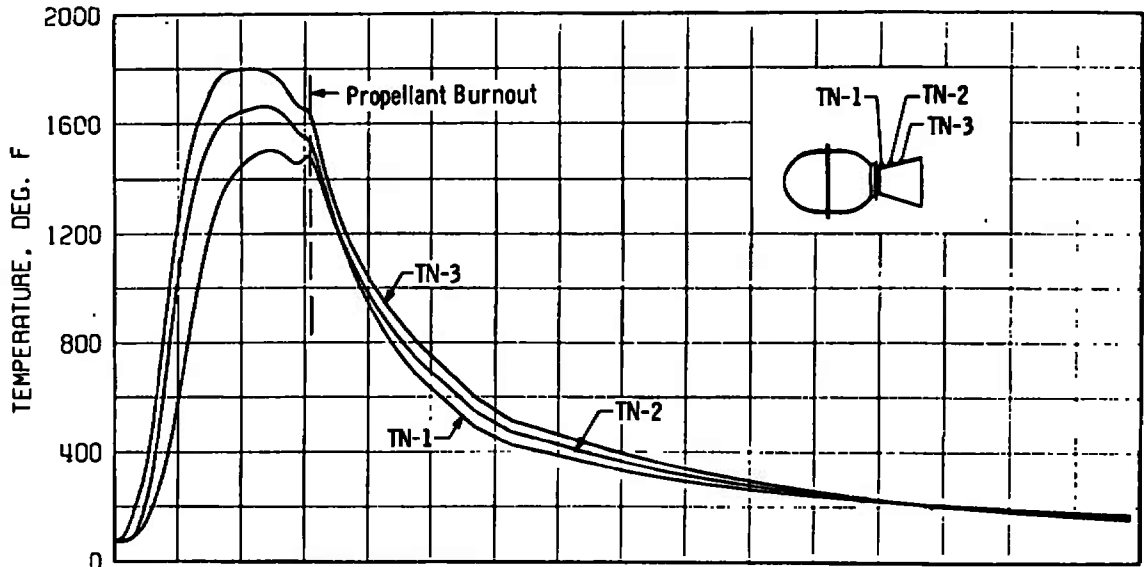
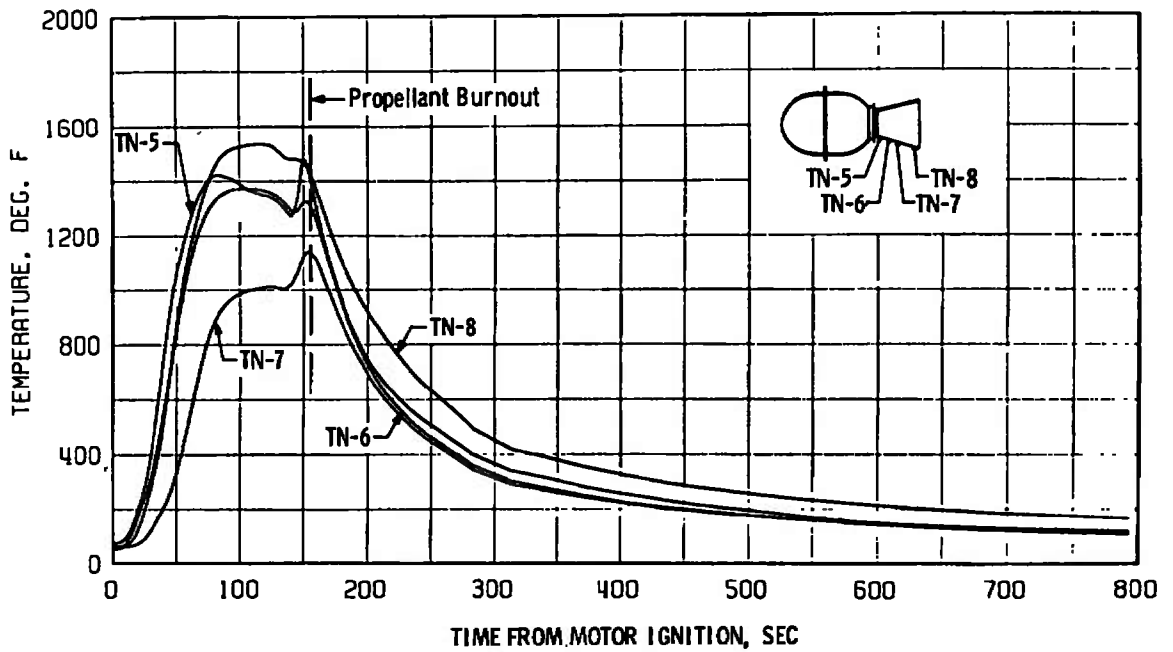

Fig. 7 Postfire Photographs of Motor Assembly



a. Nozzle Temperatures TN-1, TN-2, and TN-3



b. Nozzle Temperatures TN-5, TN-6, TN-7, and TN-8  
 Fig. 8 Motor Temperature Variation with Time

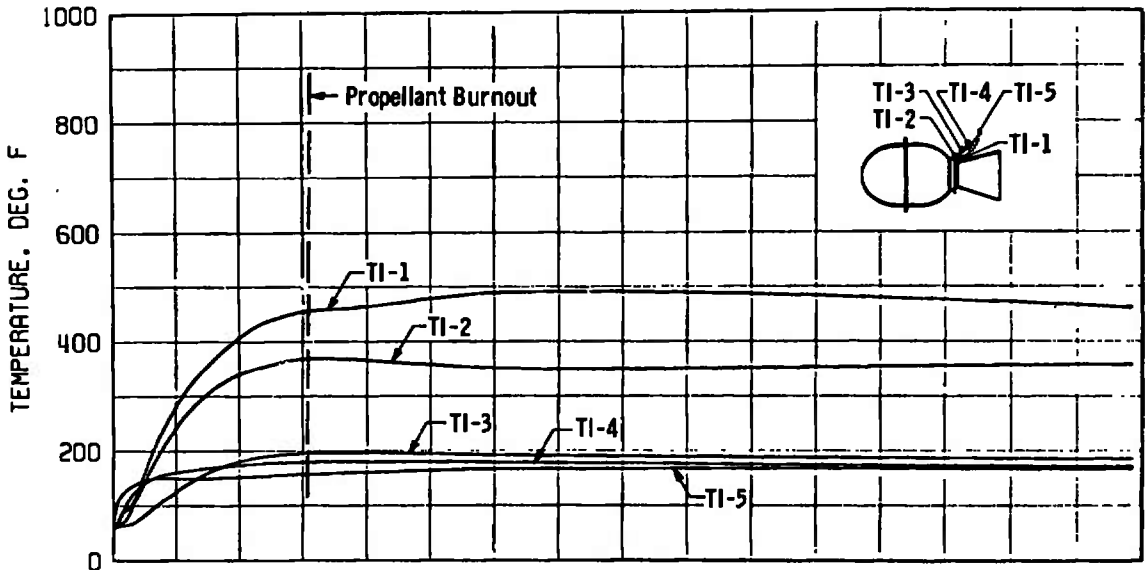

c. Igniter Case Temperatures TI-1, TI-2, TI-3, TI-4, and TI-5

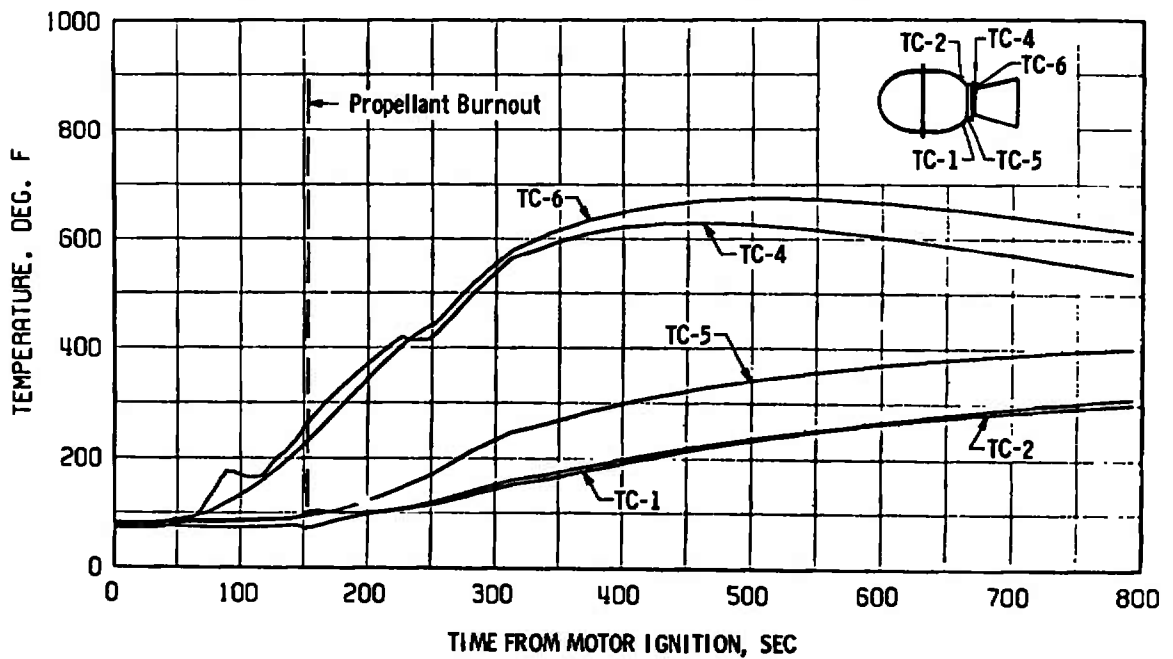

d. Case Temperatures TC-1, TC-2, TC-3, TC-4, TC-5, and TC-6  
Fig. 8 Continued

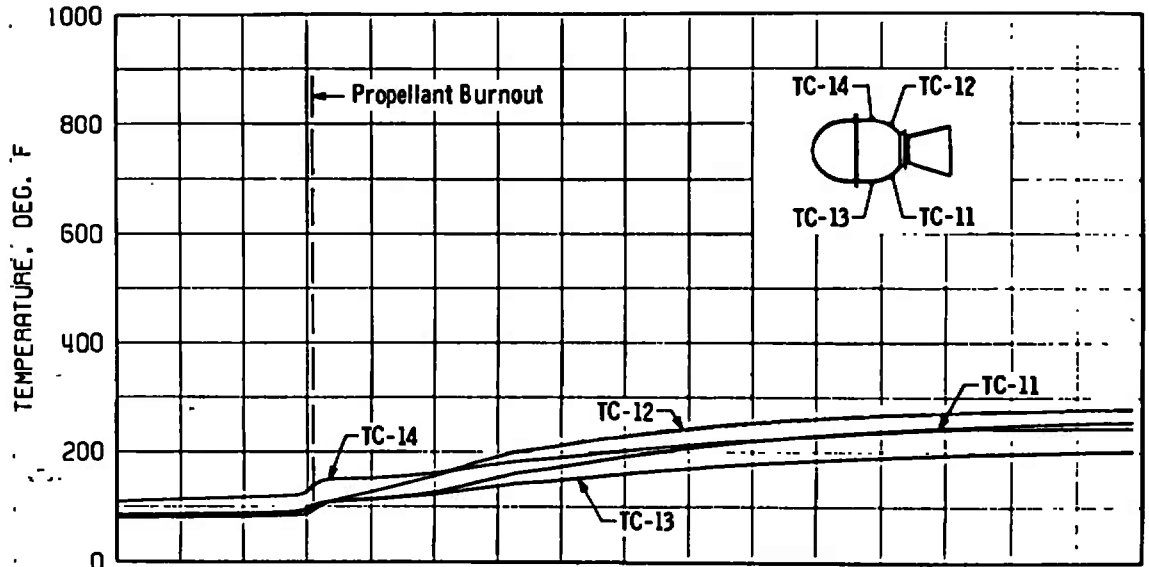

e. Case Temperatures TC-11, TC-12, TC-13, and TC-14

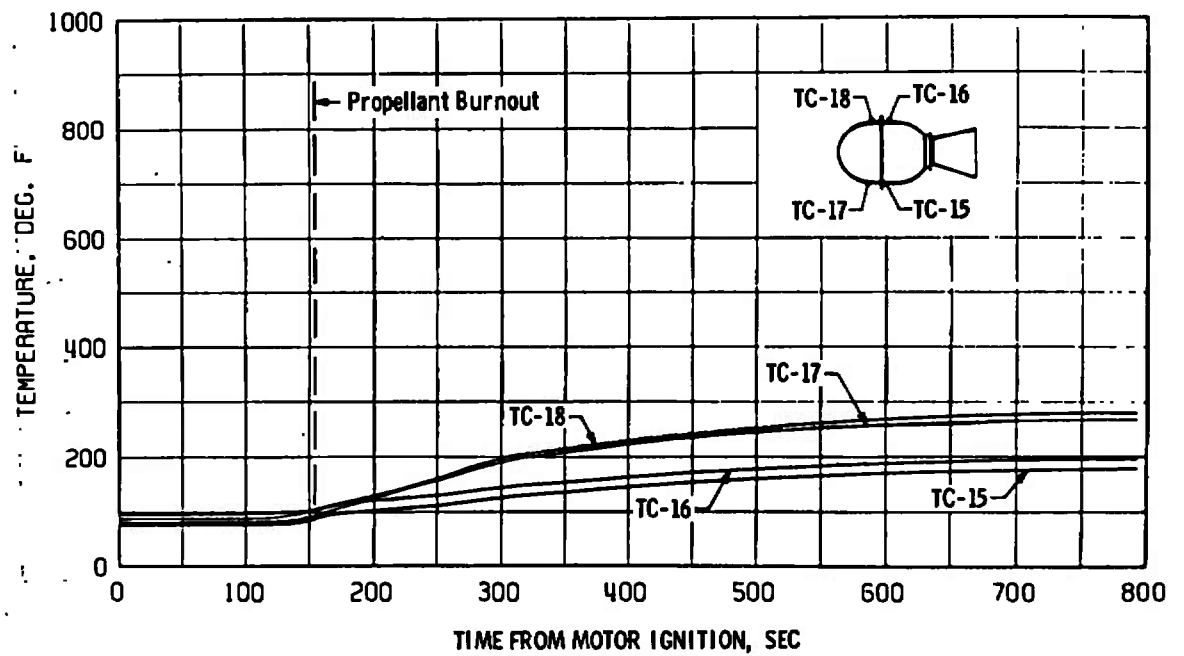

f. Case Temperatures TC-15, TC-16, TC-17, and TC-18

Fig. 8 Continued

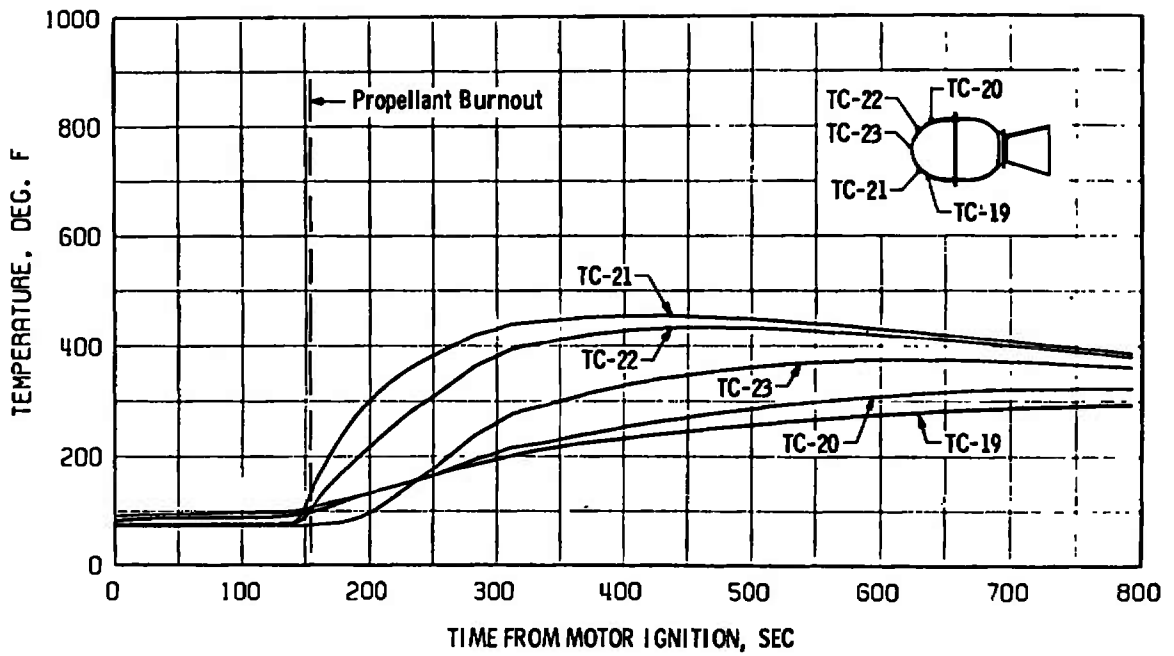

g. Case Temperatures TC-19, TC-20, TC-21, TC-22, and TC-23  
 Fig. 8 Concluded

**TABLE I  
INSTRUMENTATION SUMMARY AND MEASUREMENT UNCERTAINTY**

Parameter Designation	STEADY-STATE ESTIMATED MEASUREMENT*								Range	Type of Measuring Device	Type of Recording Device	Method of System Calibration
	Precision Index (S)			Bias (B)		Uncertainty $\pm(B + t_{95}S)$						
	Percent of Reading	Unit of Measurement	Degree of Freedom	Percent of Reading	Unit of Measurement	Percent of Reading	Unit of Measurement					
Axial Force, lbf	±0.13	---	83	+0.29	---	±0.55	---	200 to 800 lbf	Bonded-Strain-Gage-Type Force Transducers	Voltage-to-Frequency Converter onto Magnetic Tape	In-Place Application of Deadweights Calibrated in the Standards Laboratory	
Total Impulse, lb-sec	+0.116	---	>30	±0.29	---	±0.53	---				Resistance Shunt Based on the Standards Laboratory Determination of Transducer Applied Pressure versus Resistance Shunt Equivalent Pressure Relationship	
Chamber Pressure	±0.12	---	63	±0.20	---	±0.44	---	50 to 220 psia	Bonded Strain-Gage-Type Pressure Transducers			
Chamber Pressure Integral, psia-sec	±0.107	---	>30	+0.20	---	±0.41	---					
Chamber Pressure (Low Range)	±0.1% + 0.002 psia		29	-	±0.008 psia	±(0.2% + 0.012psia)		0.25 to 4 psia				
	±0.1% + 0.002 psia		38	±0.20	---	±(0.4% + 0.004psia)		4 to 100 psia				
Test Cell Pressure	±0.29	---	84	±1.25	---	±1.85	---	0.075 to 0.20 psia	Unbonded Strain-Gage-Type Pressure Transducers			
Test Cell Pressure Integral, psia-sec	+0.27	---	>30	+1.25	---	±1.80	---					
Weight, lbm	---	±0.125 lbm	>30	---	±0.02 lbm	---	±0.27 lbm	250 to 555 lbm	Beam Balance Scales	Visual Readout	In-Place Application of Deadweights Calibrated in the Standards Laboratory	
Time Interval, msec	---	±0.25 msec	>30	---	±0.01 msec	---	±0.5 msec	---	Time Pulse Generator	Photographically Recording Galvanometer Oscillograph	Time Pulse Generator Calibrated in the Standards Laboratory	
Nozzle Temperature, °F	---	±0.25°F	95	---	±2.5°F	---	±3.0°F	70 to 530°F	Chromel-Alumel Temperature Transducers	Sequential Sampling, Millivolt-to-Digital Converter, and Magnetic Tape Storage Data Acquisition System	Millivolt Substitution Based on the NBS Temperature versus Millivolt Tables	
	---	±0.25°F	95	±(0.25% + 1.2°F)	---	±(0.25% + 1.7°F)	---	530 to 1800°F				
Case Temperature, °F	---	±0.25°F	95	---	±2.5°F	---	±3.0°F	70 to 675°F	Iron-Constantan Temperature Transducers			
Pyrogen Pressure, psia	±0.075% + 0.1psia		>30	±0.15	---	±(0.3% + 0.2 psia)		50 to 220 psia	Bonded Strain-Gage Type Pressure Transducers		Resistance Shunt Based on the Standards Laboratory Determination of Transducer Applied Pressure versus Resistance Shunt Equivalent Pressure Relationship	

\*Reference: CFIA No. 180, "ICRPG Handbook for Estimating the Uncertainty in Measurements made with Liquid Propellant Rocket Engine Systems," April 30, 1969.

**TABLE II**  
**SUMMARY OF THE TE-T-607-1 MOTOR PERFORMANCE**

Test Number	01
Motor Serial Number	0006
Test Date	8/27/71
Motor Case Temperature at Ignition, °F	72
Ignition Lag Time ( $t_l$ ), sec <sup>1</sup>	0.003
Time of Nozzle Flow Breakdown ( $t_{bd}$ ), sec	139.4
Action Time ( $t_a$ ), sec <sup>2</sup>	142.0
Total Burn Time ( $t_g$ ), sec <sup>3</sup>	154.5
Simulated Altitude at Ignition, ft	116,000
Average Simulated Altitude during $t_{bd}$ , ft	98,000
Measured Total Impulse (Based on $t_{bd}$ ), lbf-sec	
Average of Four Channels of Data	62,313
Maximum Deviation from Average, percent	0.15
Chamber Pressure Integral (Based on $t_{bd}$ ), psia-sec	
Average of Three Channels of Data	21,175
Maximum Deviation from Average, percent	0.25
Cell Pressure Integral (Based on $t_{bd}$ ), psia-sec	
Average of Four Channels of Data	25.52
Maximum Deviation from Average, percent	0.13
Vacuum Total Impulse (Based on $t_g$ ), lbf-sec	66,740
Vacuum Specific Impulse, lbf-sec/lbm, Based on $t_g$ and	
Manufacturer's Stated Propellant Weight	278.60
Expended Mass (AEDC)	271.40
Average Vacuum Thrust Coefficient (Based on Total Burn Time and Average Pre- and Postfire Throat Area <sup>4</sup> ), $C_F$	1.774
Characteristic Exhaust Velocity ( $c^*$ ), ft/sec	5048
Manufacturer's Stated Propellant Weight, lbm	239.53
Expended Mass (AEDC), lbm	245.905

<sup>1</sup>Interval from application of igniter voltage to time of increase in chamber pressure

<sup>2</sup>Time interval between 10 percent of maximum chamber pressure during ignition and 10 percent of maximum chamber pressure during tailoff

<sup>3</sup>Time interval between the application of ignition voltage and the time at which the ratio of chamber-to-cell pressure has decreased to 1.3 during tailoff

<sup>4</sup>Exhaust products not removed prior to measurements

**TABLE III**  
**SUMMARY OF THE TE-T-607-1 MOTOR PHYSICAL DIMENSIONS**

Test Number - RC1261	01
Test Date	8/27/71
Motor Serial Number	0006
Expended Mass (Includes Igniter) (AEDC), lbm	245.905
Manufacturer's Stated Propellant Weight, lbm	239.53
Nozzle Throat Area, in. <sup>2</sup>	
Prefire	1.65
Postfire	1.94
Percent Change from Prefire	17.60
Average	1.80
Nozzle Exit Area, in. <sup>2</sup>	
Prefire	133.7
Postfire	134.0
Percent Change from Prefire	0.22
Average	133.85
Nozzle Area Ratio, $A_{ex}/A_t$	
Prefire	81
Postfire	69
Average	75

## DOCUMENT CONTROL DATA - R &amp; D

(Security classification of title, body of abstract and indexing annotation must be entered when the overall report is classified)

1 ORIGINATING ACTIVITY (Corporate author) Arnold Engineering Development Center, Arnold Air Force Station, Tennessee 37389		2a. REPORT SECURITY CLASSIFICATION <b>UNCLASSIFIED</b>	
		2b. GROUP N/A	
3 REPORT TITLE EVALUATION OF THE THIOKOL TE-T-607-1 MOTOR AT SIMULATED ALTITUDE CONDITIONS			
4 DESCRIPTIVE NOTES (Type of report and inclusive dates) August 27, 1971--Final Report			
5. AUTHOR(S) (First name, middle initial, last name) A. A. Cimino, ARO, Inc.			
6 REPORT DATE March 1972	7a. TOTAL NO OF PAGES 33	7b. NO. OF REFS 2	
8a. CONTRACT OR GRANT NO.	9a. ORIGINATOR'S REPORT NUMBER(S) AEDC-TR-72-13		
b. PROJECT NO. Program Element 921E4	9b. OTHER REPORT NO(S) (Any other numbers that may be assigned this report) ARO-ETF-TR-71-231		
c.			
d.			
10. DISTRIBUTION STATEMENT Approved for public release; distribution unlimited.			
11 SUPPLEMENTARY NOTES Available in DDC		12 SPONSORING MILITARY ACTIVITY NASA/JPL TET Project Manager Pasadena, California 91103	
13 ABSTRACT One Thiokol Chemical Corporation TE-T-607-1 solid-propellant rocket motor was successfully fired at an average simulated altitude of 98,000 ft. The program objectives were to determine vacuum ballistic performance after temperature conditioning at 70°F, to determine altitude ignition characteristics, to evaluate motor structural integrity, and to determine motor temperature-time history at selected critical locations during and after motor operation.			

14.	KEY WORDS	LINK A		LINK B		LINK C	
		ROLE	WT	ROLE	WT	ROLE	WT
	performance altitude simulation solid-propellant rocket motor structural stability ballistics						

APFC  
Amold APB Team