

(Security classification of title, body of abstract and illustration must be entered when the overall report is classified)

1. ORIGINATING ACTIVITY (Corporate author) Aerospace Medical Research Laboratory Aerospace Medical Div, Air Force Systems Command Wright-Patterson Air Force Base, Ohio 45433	20. REPORT SECURITY CLASSIFICATION Unclassified 21. GROUP N/A
--	--

3. REPORT TITLE
 DYNAMIC SIMULATION TECHNIQUES FOR THE DESIGN OF ESCAPE SYSTEMS: CURRENT APPLICATIONS AND FUTURE AIR FORCE REQUIREMENTS

4. DESCRIPTIVE NOTES (Type of report and inclusive dates)

5. AUTHOR(S) (First name, middle initial, last name)
 JAMES W. BRINKLEY AND JOHN T. SHAFFER

6. REPORT DATE December 1971	76. TOTAL NO. OF PAGES 33 35	77. NO. OF REFS 23
---------------------------------	--	-----------------------

8. CONTRACT OR GRANT NO. A. PROJECT NO. 7231	96. ORIGINATOR'S REPORT NUMBER(S) AMRL-TR-71-29 Paper No 2 99. OTHER REPORT NO(S) (Any other numbers that may be assigned this report)
---	---

10. DISTRIBUTION STATEMENT
 Approved for public release; distribution unlimited

11. SUPPLEMENTARY NOTES	12. SPONSORING MILITARY ACTIVITY Aerospace Medical Research Laboratory Aerospace Medical Div, Air Force Systems Command, Wright-Patterson AFB, OH 45433
-------------------------	---

13. ABSTRACT
 The Symposium on Biodynamics Models and Their Applications took place in Dayton, Ohio, on 26-28 October 1970 under the sponsorship of the National Academy of Sciences - National Research Council, Committee on Hearing, Bioacoustics, and Biomechanics; the National Aeronautics and Space Administration; and the Aerospace Medical Research Laboratory, Aerospace Medical Division, United States Air Force. Most technical areas discussed included application of biodynamic models for the establishment of environmental exposure limits, models for interpretation of animal, dummy, and operational experiments, mechanical characterization of living tissue and isolated organs, models to describe man's response to impact, blast, and acoustic energy, and performance in biodynamic environments.

Reproduced from best available copy. 

Details of illustrations in this document may be better studied on microfiche

D D C
 RECEIVED
 APR 26 1972
 RECEIVED
 C

Best Available Copy

Reproduced by
 NATIONAL TECHNICAL INFORMATION SERVICE
 Springfield, Va. 22151

DD FORM 1 NOV 68 1473

AD 740439

DYNAMIC SIMULATION TECHNIQUES FOR THE DESIGN OF ESCAPE SYSTEMS:
CURRENT APPLICATIONS AND FUTURE AIR FORCE REQUIREMENTS

James W. Brinkley and John T. Shaffer

Aerospace Medical Research Laboratory
Wright-Patterson Air Force Base, Ohio

INTRODUCTION

The applications of biodynamic data within the United States Air Force are numerous and many are vitally important but the most critical of these applications is in the development of emergency escape systems for aircraft. In this application these data determine, to a large extent, the actual capabilities or performance limitations of the systems that are designed. These capabilities or the lack of capabilities ultimately determine whether the aircraft crewman will survive an aircraft emergency. The designer of escape systems must be able to provide a design that is capable of meeting this life or death situation and still produce a design that is lightweight, requires minimum cockpit space, requires little maintenance, withstands high crash loads, and yet provides a reasonably comfortable platform for the performance of flight control, instrumentation monitoring, and other crew duties. In such a design problem, constrained by so many factors, the design criteria must be defined with appropriate precision for there is no latitude for overdesign since it will be reflected in weight, size, and ultimately in the compromise of the performance of the aircraft.

The biodynamic properties of the crewman that directly effect the design of escape systems include those influencing acceleration exposure limits, the inertial response of the human body to acceleration and the response of the body to a high velocity airstream. The relationships between these properties and the performance capability of an escape system can be understood more completely by studying the performance envelope of an escape system. Figure 1

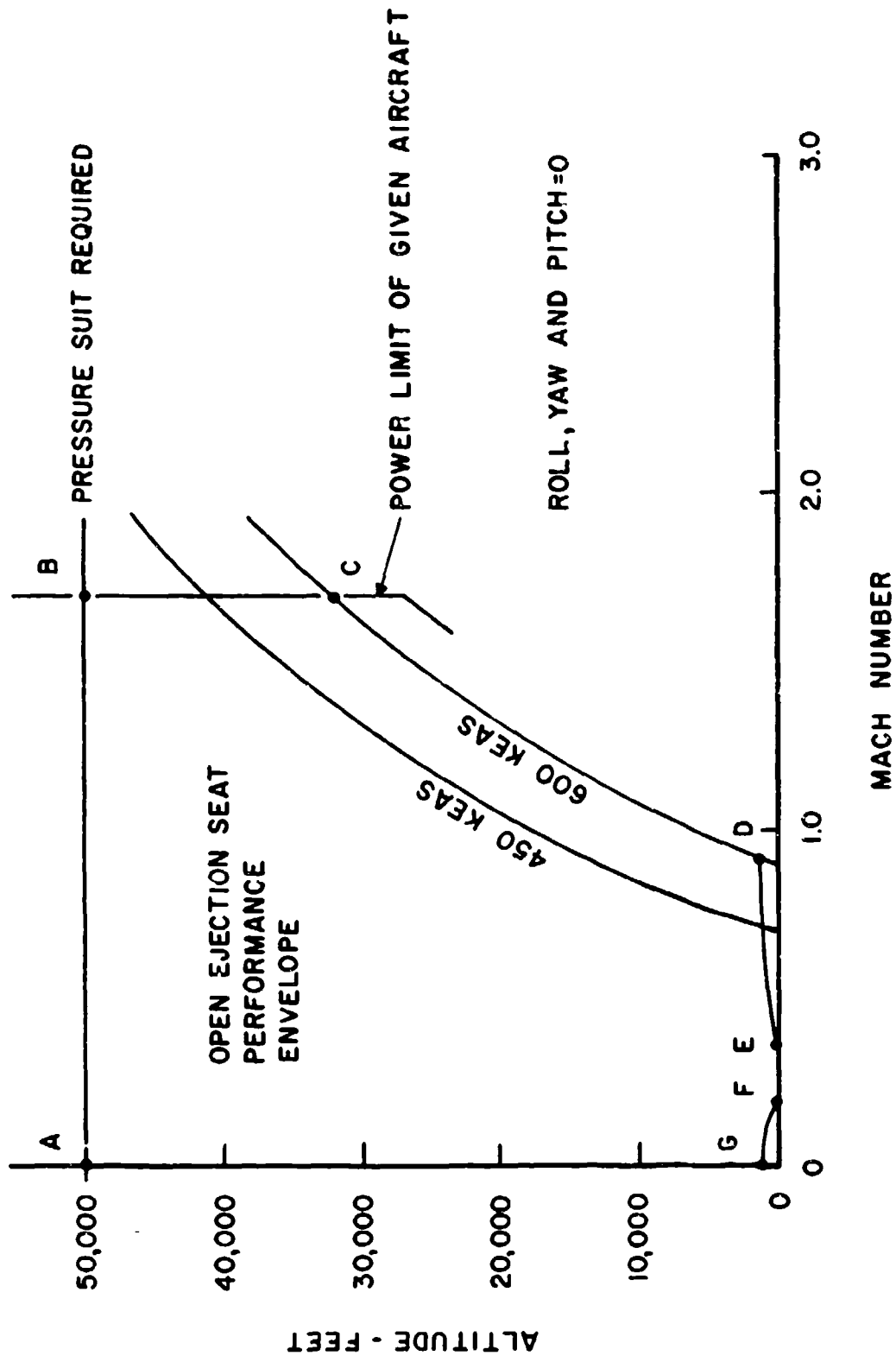

Figure 1. Typical Escape System Performance Envelope (Ref 1).

depicts the performance limits of an open ejection seat for aircraft altitudes and Mach number combinations if the aircraft flight is straight and level at the time of ejection initiation. The region within the area defined by the line connecting the points ABCDEFG is usually accepted as a region where survivable escape is probable. Note that this type of a representation of system performance is a gross simplification as other graphs are actually necessary to more completely describe the capabilities of a system for other combinations of altitude, speed, and aircraft flight conditions, i. e., attitude and sink rate.

The line CD is a limit created by two factors, flailing of the crewman's head and limbs and rapid deceleration of the crewman and seat after entry into the airstream. These factors are interrelated and have caused most of the major injuries and one-half of the fatalities experienced in Air Force ejections initiated at airspeeds above 500 KEAS. Furthermore, all ejections initiated above 500 KIAS during the period of January 1968 to December 1970 have resulted in fatality or major injury to the ejectee (ref 2). Shannon's study of Air Force operational ejection experience in this time period has shown that limb flailing has occurred with violence sufficient to cause injury in ejections at airspeeds as low as the 250-300 KIAS range and is the second largest cause of major injuries associated with escape system use (the primary cause is ejection acceleration), accounting for 12 percent of the total number of major injuries.

Human tolerance to parachute opening shock and the structural adequacy of the parachute canopy form the criteria for establishment of the limit between points E and D. The ejectee must have adequate altitude at the time of ejection to permit deceleration to a velocity which will not produce injurious opening shock or destroy the parachute canopy. Fortunately, the number of parachute opening shock injuries that have been experienced during Air Force operations is low. Shannon reported only five major injuries resulting from parachute opening shock in his study of 384 ejections (ref 2). This area is receiving some renewed interest, however. Parachute canopies currently under development

employ new stronger materials which are capable of withstanding loads as much as 30 percent higher than those that can be tolerated now without destruction of the canopy.

The trajectory height that the escape system achieves is the critical factor in establishing the limit from point E through F and G. This limit represents the airspeeds and altitudes beyond which the trajectory height will not be adequate to provide complete deployment of the personnel parachute prior to contact with the ground. Point G is the maximum aircraft altitude where safe escape can be accomplished without forward airspeed. The improved performance in the area between points G and F results from the fact that the stabilization of the seat by a drogue parachute and deployment of the recovery parachute are aided by the horizontal velocity at the time of ejection. Some escape systems can provide escape in the area between the points F and E in cases where the ejection is initiated at ground level. Such capability is possible for several reasons. First, the ejection catapult produces an impulse that is adequate to achieve a trajectory to meet the parachute deployment altitude requirement. Second, the seat is relatively stable during the burning of the sustainer rocket. Early ejection seat designs employed a ballistic catapult that would propel the ejection seat up guide rails. The seat velocity that could be achieved was limited by the relatively short acceleration stroke thereby available and the human tolerance to acceleration in the $+G_z$ direction. The capability of this concept was so limited that it was difficult to provide clearance of the vertical stabilizer of the aircraft at higher airspeeds without exceeding human tolerance. Addition of a rocket catapult solved the fin clearance problem and provided the total impulse necessary to reach adequate parachute deployment altitudes during ground level ejections. Nevertheless, safe escape at ground level was not immediately attainable if the airspeed was low since, without an effective drogue parachute, the seat would usually pitch forward and much of the rocket thrust would be used to drive the seat toward the ground. This reaction was caused by the initial pitching moment that was usually required to overcome the tendency for the seat to pitch backward at high speed and the inertial response

of the ejectee to the catapult acceleration which causes a misalignment between the rocket thrust vector and the seat-man center-of-gravity as shown in Figure 2. Studies of the inertial response characteristics of the human body and the incorporation of stabilization systems such as gyro-controlled vernier rockets have led to solutions to this problem.

Additional critical operational problems that are not shown by our review of the escape system performance envelope but which represent serious challenges to biodynamic research are the problems of ground impact acceleration environments associated with encapsulated ejection seats and crew module escape systems and, a similar problem, the accelerations associated with fixed wing aircraft or helicopter crash. These problems are both characterized by acceleration environments of irregular waveform, varying acceleration vector directions, and multiple impacts. The human response to these environments can not be satisfactorily assessed using simple geometric approximations of the waveforms to extrapolate to laboratory data; furthermore, the existing data are generally inadequate to completely define human acceleration exposure limits in any but the $+G_z$ direction. The importance of correcting this situation cannot be overemphasized since this problem has crucial effects on civilian safety programs as well as the design of protective equipment for military applications.

The use of modeling techniques to guide in the development of pertinent experimental hypotheses and the analysis of experimental data provides a proven method to approach these problems in the most expeditious and meaningful fashion. Furthermore, the use of these techniques provides a method to handle the complexities of the environmental inputs as well as the complexities of the human response and yet do so in a format that can be relatively easily used by designers of safety equipment.

The intent of this paper is to describe applications of this approach that have been made by the Air Force and its contractors and to highlight problem areas where more work is required to meet Air Force requirements for crew safety.

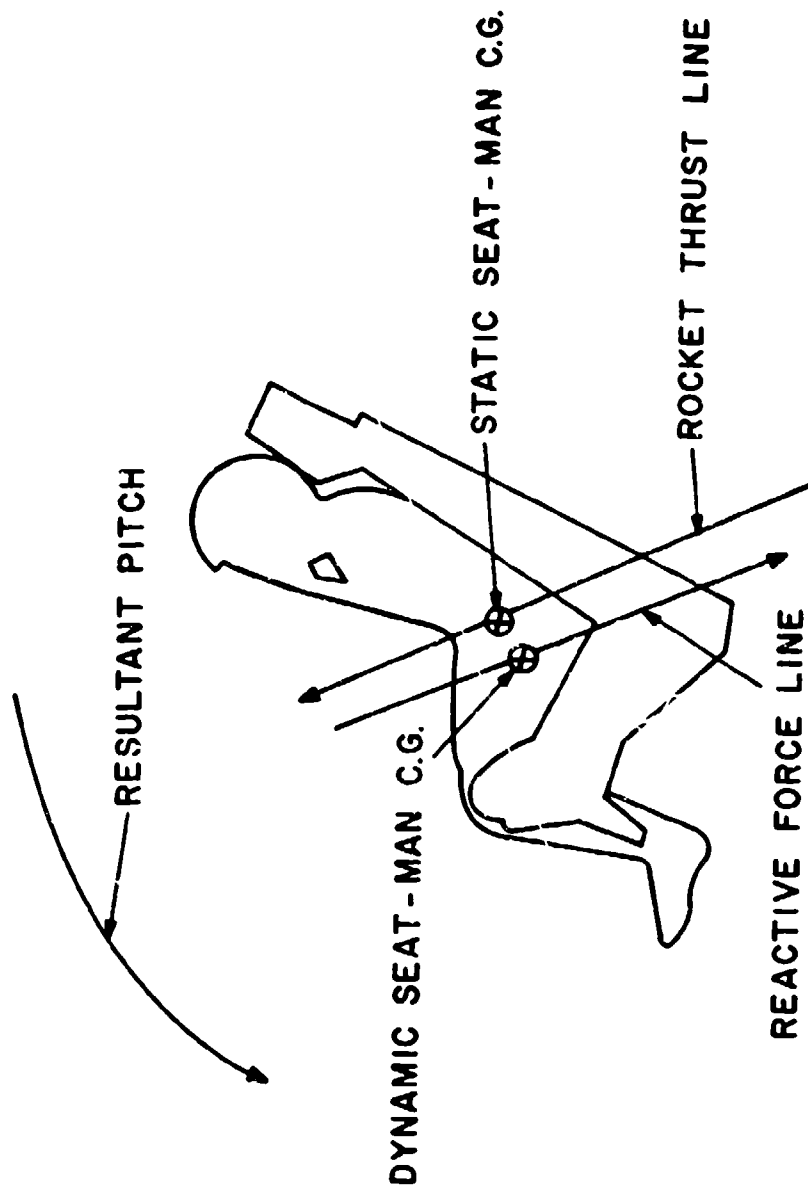

Figure 2. Pitching Caused by Misalignment of Rocket Thrust Vector and Seat-man c.g.

SPINAL INJURY MODEL

The method currently in use by the Air Force and its contractors to determine exposure limits for short duration $+G_z$ acceleration produced by ejection catapult is perhaps the most important recent aeromedical contribution to the field of ejector system design. This method is used in the Air Force specifications for upward ejection seats and encapsulated escape systems (refs 3, 4). It involves the use of a simple mechanical model to predict the probability of spinal injury, i. e., compression fracture of the vertebral body segments. The model is a simple mechanical system composed of the common lumped-parameter elements, a mass, a spring and a viscous damper. The response of the model, shown in Figure 3, is computed by solving the equation:

$$\frac{d^2 \delta}{dt^2} + 2 \zeta \omega_n \frac{d\delta}{dt} + \omega_n^2 \delta = \frac{d^2 z}{dt^2}$$

where:

- δ = deflection (in.)
- ζ = damping ratio
- ω_n = natural frequency of the model (rad/sec)
- z = acceleration input (in/sec²)

Assuming failure of the vertebral column can be related to the deflection of the structure, the deflection of the model is determined and used to calculate the Dynamic Response Index:

$$DRI = \frac{\delta_{\max} \omega_n^2}{g}$$

where:

- δ_{\max} = the maximum deflection of the model (in.)
- g = 386 in/sec²

Although biodynamic application of this type of procedure was first described by Payne in reference 5 the properties of the model used in the Air Force escape systems specification were determined by Stech and Payne

8

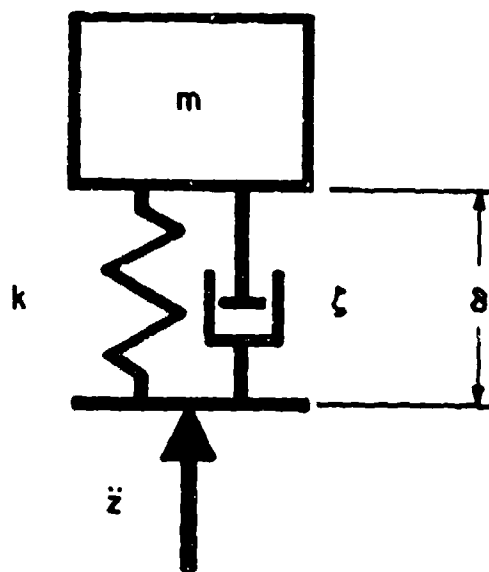
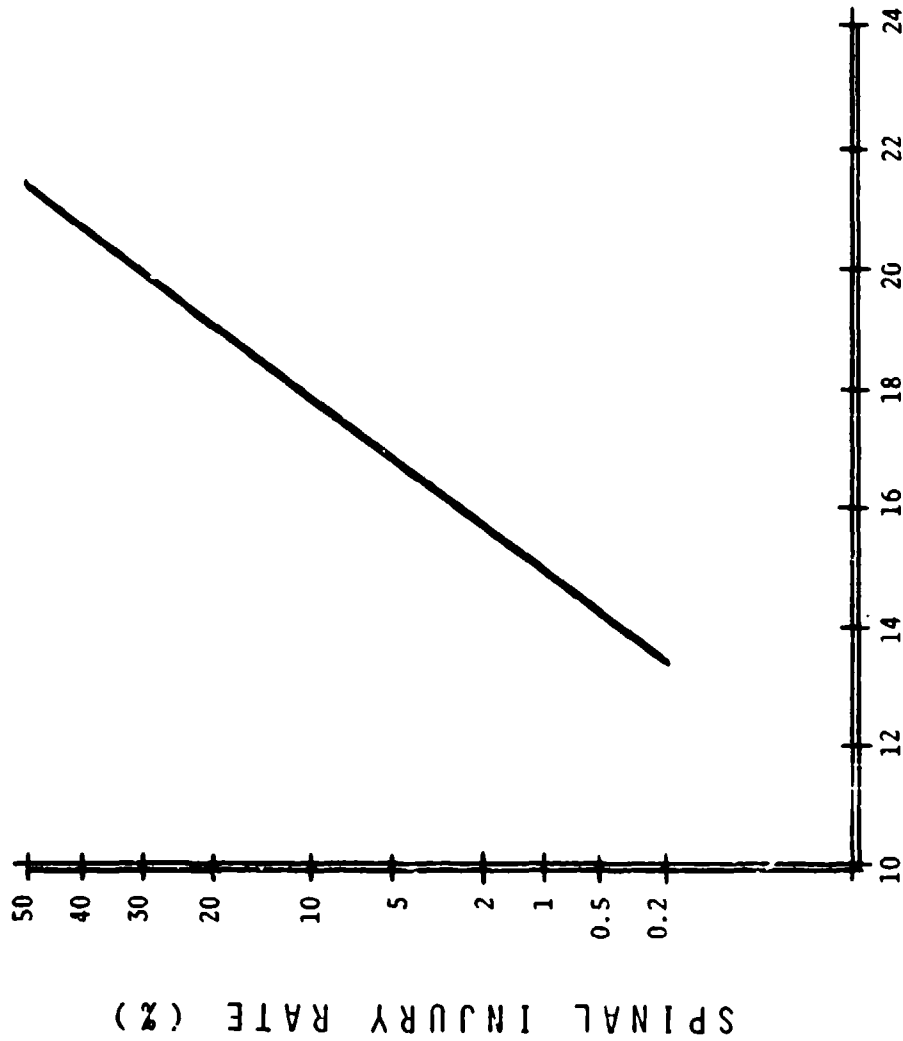

Figure 3. Spinal Injury Model.

using existing experimental data. The reader is directed to reference 6 for the sources of data and the procedures that were used. The values of ζ and ω_n that were chosen for use in the specifications, 0.224 and 52.9 radians per second, were selected as values that had been computed by Stech and Payne as representative of the mean age of the Air Force flying population (ref 8) at acceleration levels of approximately 20G. The breaking strength of the vertebral bodies was also calculated by Stech and Payne using data obtained from tests of cadaver specimens. To develop an initial estimate of the probability of injury, i. e., probability of a compression fracture of the spine, for given DRI values, Stech and Payne determined the 50 percent probability of injury levels for several age groups. For age 27.9 years, the mean of the Air Force flying population, the 50 percent probability of injury level was estimated to be at a DRI of 21.3.

The probability of injury over a range of DRI values can be calculated assuming a normal distribution and that the relationship between vertebral breaking strength and body weight is random. The validity of a normal distribution is discussed more thoroughly by Payne elsewhere in this Symposium. The assumption of no relationship between breaking strength and body weight is at least partially supported by Shannon (refs 2, 9) in his reviews of spinal injuries due to ejection force. Using these assumptions the estimate shown in Figure 4 was computed by determining the variance of the quotient of breaking strength and body weight distributions (ref 10). Band, in the appendix to Payne's presentation within this Symposium has computed the distribution for several levels of dependence of breaking strength on body weight which serves to provide some insight into the influence of the assumption that has been used.

Before the model could be introduced in the specifications a study was conducted to determine the accuracy of the model when its predictions were compared to operationally experienced spinal injury rates (ref 1). DRI values were calculated using data obtained from ejection catapult test programs. The calculations were accomplished for the case of a 50th percentile weight crewman



DYNAMIC RESPONSE INDEX

PROBABILITY OF INJURY ESTIMATED FROM LABORATORY DATA

Figure 4. Initial Estimate of Probability of Spinal Injury

and his personnel equipment. The catapult acceleration that was used was representative of the performance of the catapult if the pre-ignition temperature is 70°F, the nominal aircraft cockpit temperature. The results of these calculations are plotted in Figure 5. Only compression fractures that were attributed to ejection acceleration by the accident investigation have been considered. The initial estimate of the injury probability distribution based on cadaver data is also shown in Figure 5 and compared to the distribution estimated from the operational data. Since the data obtained from the analysis of operational injuries was not considered adequate to determine a unique distribution, the slope of the line drawn through the data points was established on the basis of the slope of the initial estimate but the breaking strength was increased to coincide with the operational findings.

The spinal injury model was first used as a design and evaluation tool during the development of the F-111 crew escape module. Although this application was originally intended only to be an experimental application, the unusual acceleration environment measured during rocket sled ejections could not be evaluated using more conventional methods. The +G_z acceleration-time history shown in Figure 6 was measured at the c. g. of the crew module during ejection. The initial portion of the acceleration profile, caused by rocket gas pressure buildup between the crew module and the aircraft fuselage prior to module separation, represented the most difficult problem. The rate of onset was at minimum at least 1000 G/sec while the maximum allowable rate of onset by the existing design limitations was 300 G/sec. Analysis of the pulse using the spinal injury model revealed that the DRI values were relatively lower than had been anticipated and the probability of spinal injury, at least for lower airspeed (450 KEAS), was not considered to be excessive, and thus, a redesign of the crew module and the aircraft fuselage was avoided.

Since adoption of the spinal injury model in Air Force specifications it has been used in the evaluation of several operational problems and is currently being used in the development of the Advanced Concept Ejection Seat for the Air Force Life Support Systems Program Office and in the development

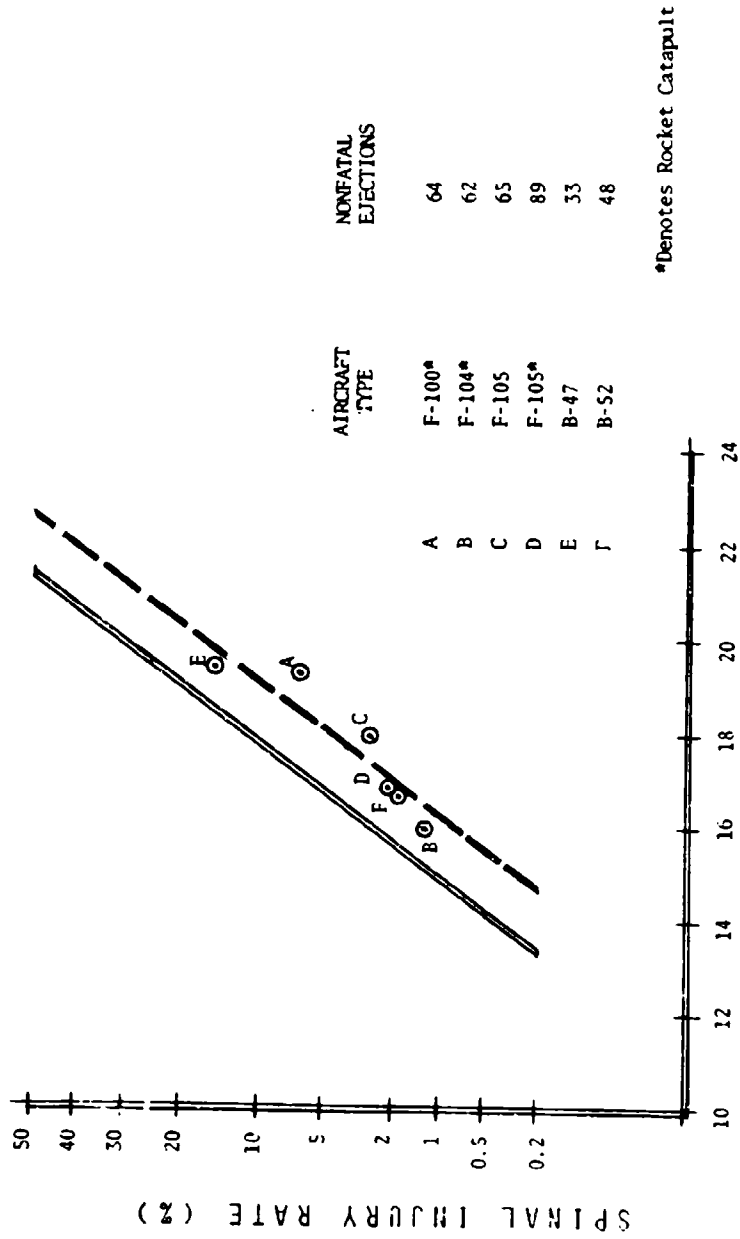

DYNAMIC RESPONSE INDEX

PROBABILITY OF SPINAL INJURY ESTIMATED FROM LABORATORY DATA COMPARED TO OPERATIONAL EXPERIENCE

Figure 5. Probability of Spinal Injury Estimated from Operational Experience.

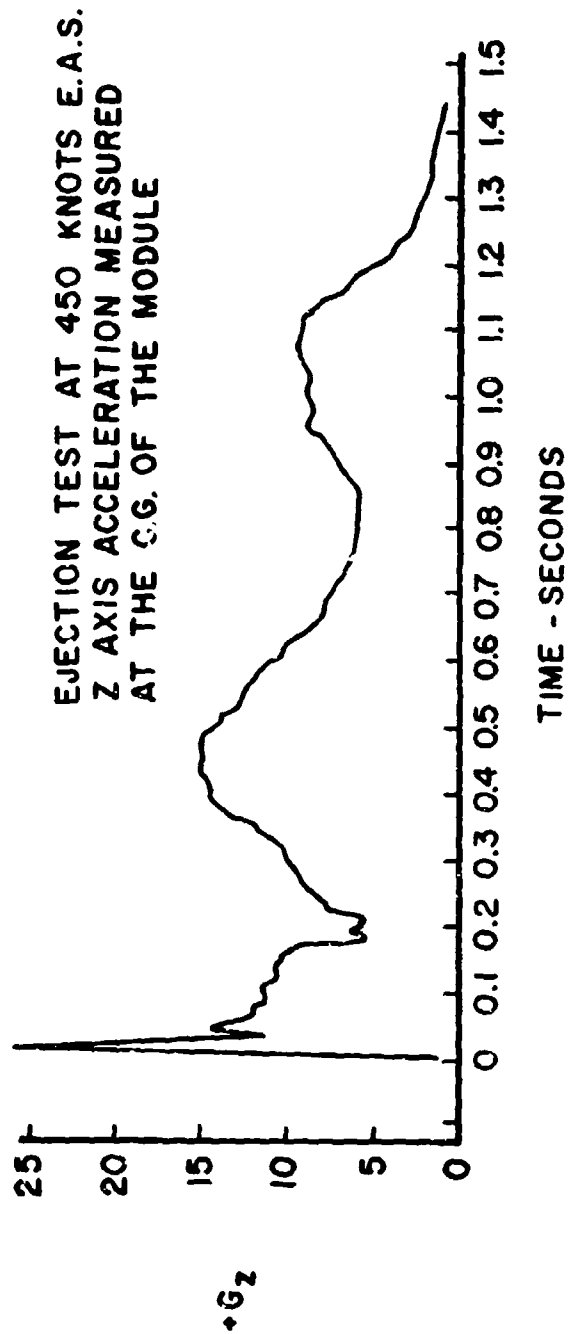

Figure 6. F-111 Acceleration-time History.

+Gz

of the B-1 Crew Escape Module. The technique is also being applied on a consultative basis in the development of the SIIS-3 ejection seat development program for the Naval Air Systems Command. Carr and Phillips (ref 11) have used the technique to study the design of energy absorption systems for helicopter crash environments. Payne (refs 12) has described the application of the spinal injury model in the development of personnel restraint systems and ejection seat cushions. The application that has had the most pronounced operational effect is the assessment of the spinal injury problem that existed with use of the ejection seat in the F-4 aircraft. During the period of 1966 to 1968 use of the F-4 escape system by Air Force crewman resulted in an unusually high incidence of vertebral compression fracture. The spinal injury rate during this period averaged approximately 41 percent of the total number of nonfatal ejections. An estimated 84 percent of these injuries (34 percent of the total nonfatal ejections) were attributed to the ejection force. These statistics contrasted sharply with the relatively low spinal injury rate averaging approximately 4 percent experienced with other Air Force ejection seats during the same period. The DRI that was calculated for the F-4 catapult was 19 which would be related to an injury rate of approximately 9 percent if the model prediction could be directly applied to this case. However, the ejection seat (Fig. 7) used in the F4 does not permit the crewman's vertebral column to be aligned with the catapult acceleration vector as in other Air Force ejection seats (ref 14). Furthermore, the Air Force procedure of using the D-ring ejection initiation handle to decrease the time required to eject eliminated the upper torso restraint advantage obtained with use of the face curtain initiation technique. The advantages of the face curtain technique have been described by such investigators as Martin, Latham, Bosee, and Kazarian (refs 15, 16, 17, 18). Although the spinal injury model predictions of injury are intended to be used in only those cases where there are less than 5 degrees of misalignment, Brinkley and Mohr (ref 19) hypothesized that the injury threshold would be lower in the misalignment case but the variance might be the same. On the basis of this proposition a spinal injury rate of 5 to 10 percent was estimated for a reduced charge catapult producing a DRI of 16, the minimum charge allowable without



Figure 7. F-4 Ejection Seat Compared to other Air Force Ejection Seat.

serious compromise to the performance envelope of the F-4 escape system. Incorporation of the reduced charge catapult in addition to a more easily tightened lap belt and an optimally contoured seat resulted in a major reduction in the spinal injury rate. As of 31 December 1969 the overall spinal injury rate had been reduced to 8 percent of the total nonfatal ejections (ref 20). * Ejection force was attributed to be the cause of injury in 9 ejections and 1 injury was related to parachute landing impact. The medical investigators designated 3 injuries as caused by either ejection force or landing impact. The marked reduction of landing impact injuries is generally attributed to be the result of incorporation of a lower sink rate parachute, i. e., a 28 ft. diameter canopy rather than the 24 ft. canopy that had been used.

INERTIAL RESPONSE MODEL

The primary reason for the development of a model to represent the inertial response characteristics of the entire human body was the practice to represent the crewman as a rigid mass in attempts to study escape system stability analytically. This procedure was known to be erroneous by observation of the trajectory of ejection seats during ground level test firings of these seats at zero airspeed. The pronounced forward pitching of the seat was related to the "body slump" of the dummy or, in the operational case, the crewman and the corresponding displacement of the seat-man center-of-gravity with respect to the rocket thrust vector as discussed earlier. To correct the performance, changes have been made to the rocket nozzle angle on a cut and try basis during development test until a successful recovery could be made. This approach has been quite uneconomical and furthermore it is fallacious as it assumes that the dummy will respond to the acceleration in the same manner as the human body. Coermann's study of the mechanical impedance of both human subjects and anthropomorphic dummies (ref 21) demonstrated that such an approach would be incorrect. The final result of this cut and try approach has been the development of a center-of-gravity envelope which is believed to cover the full range of variations of c. g. due to anthropometrics, personnel equipment configurations

*See Figure 8.

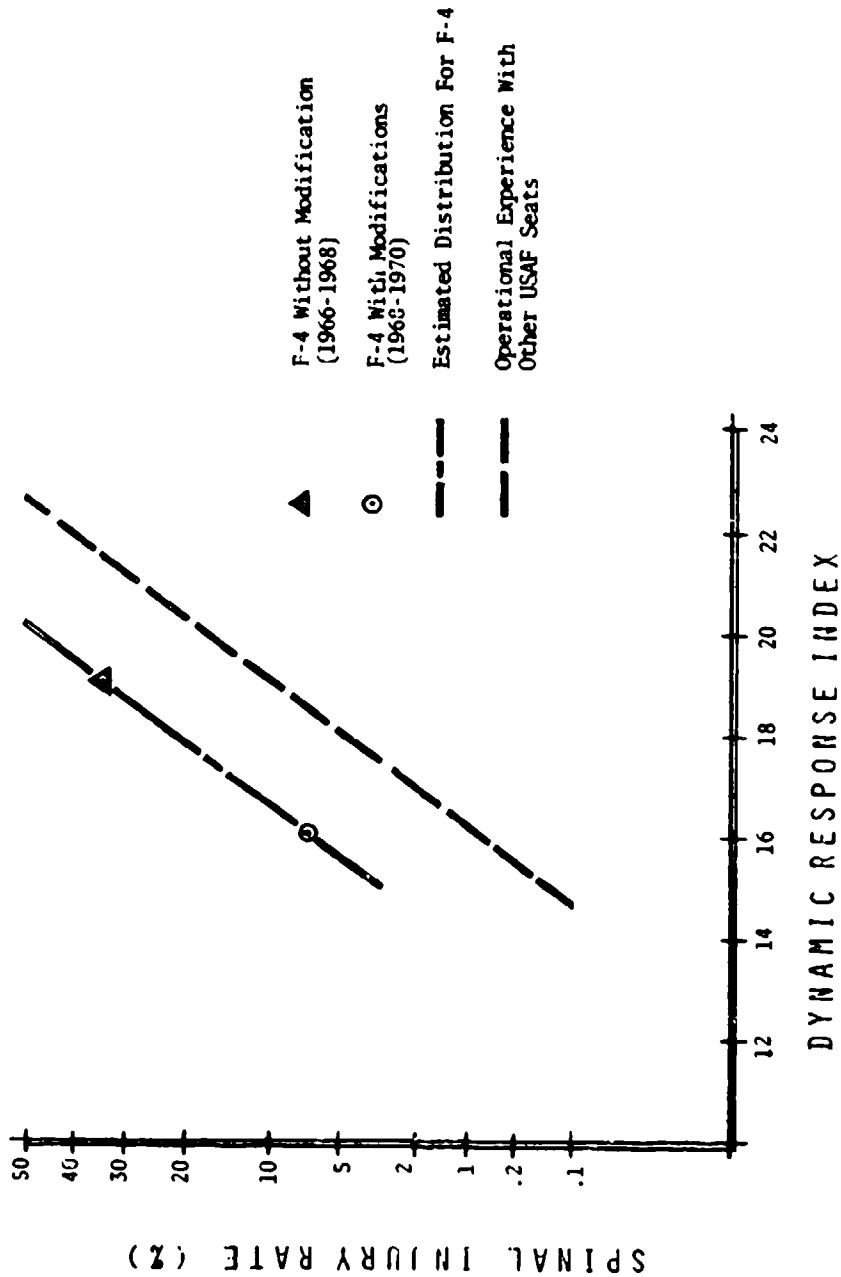

Figure 8. Comparison of Spinal Injury Rates before and after Modification of F-4 Ejection Seat.

and movement of the c. g. due to the acceleration. This empirical procedure ignores the dynamic response characteristics of the human body and therefore, will work only if it works at all, for similar ejection acceleration waveforms.

The initial attempts to provide data to improve the procedure were all directed toward the measurement of the c. g. shift of the human body during acceleration. Douglas Aircraft attempted to determine the maximum excursion of the c. g. by measuring the position of the c. g. during centrifuge tests with human subjects (ref 22). Further work was accomplished by McDonnell Aircraft and the Naval Aircrew Equipment Laboratory to measure the motion of the c. g. by photometrically measuring the motion of targets placed on body segments of human test subjects (ref 24). The centrifuge technique was, of course, limited to the evaluation of steady-state response but beneficial nonetheless as the measurements of the static excursions of the whole body c. g. provide important limit condition data for the eventual development of a dynamical description. The photometric data that was collected must be approached with considerable caution, however. Although it is possible to determine the position of the c. g. of a multisegment system by knowing the weights of the segments and measuring the position of the segments, in actual practice an accurate measurement of the position of the major segments of the human body is impossible to achieve since the motion of the internal viscera cannot be determined photometrically. Nevertheless, the data contained in reference 23 represented a step forward into a more complete understanding of the dynamic phenomenon.

The Aerospace Medical Research Laboratory began experimental work in 1963 to measure the movement of the c. g. of the human body as a function of time. The initial work that was done was fraught with considerable difficulty. Attempts to measure the c. g. shift in the plane perpendicular to the acceleration vector produced erroneous data as described by Brinkley in reference 24. A theoretically accurate scheme was then developed and a test seat supported by six force cells was designed and fabricated as shown diagrammatically in Figure 9. Briefly, the procedure used consisted of measurement of the inertial response of the seat-man combination and the acceleration of the seat, calculation

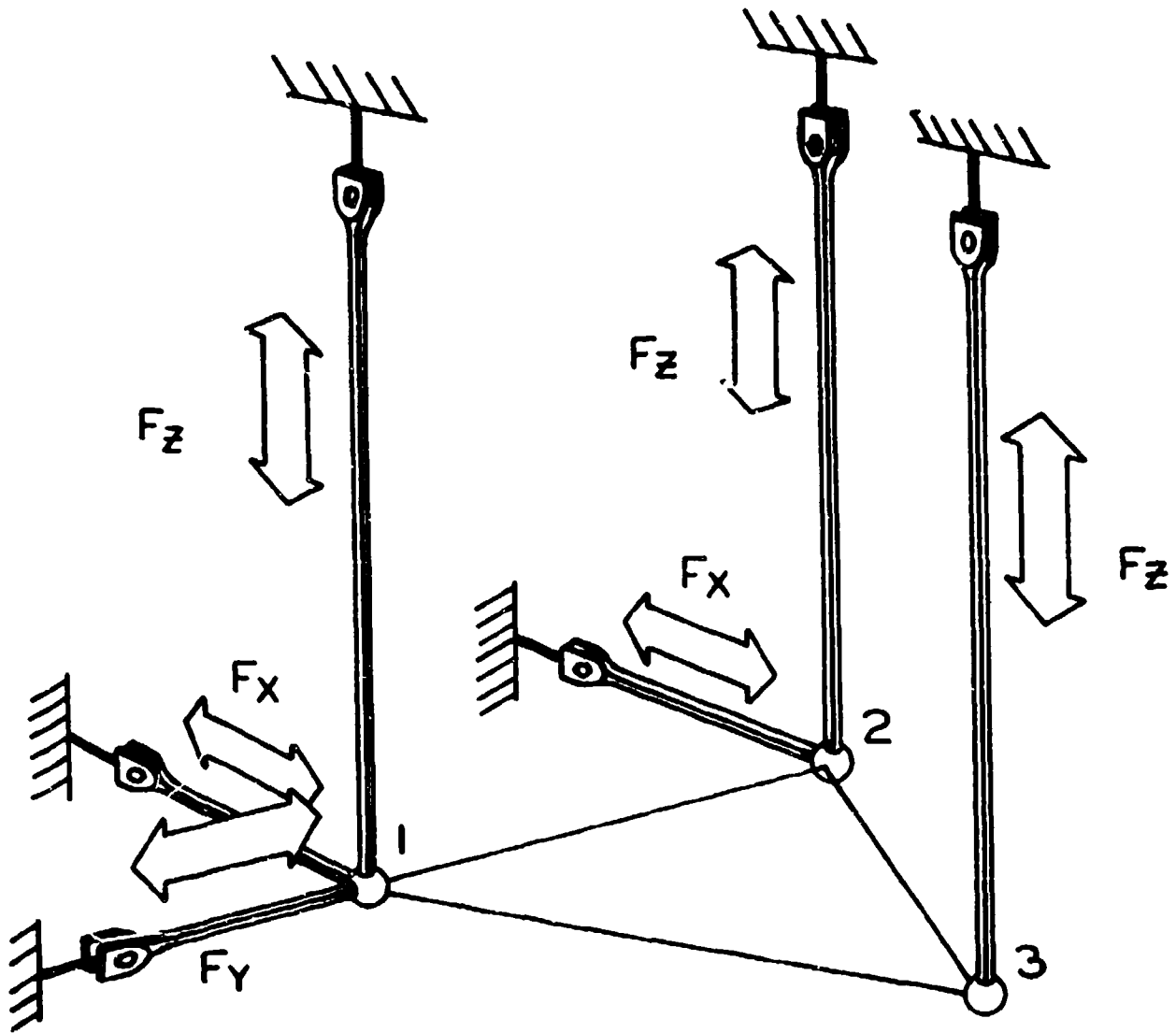

Figure 9. Test Apparatus to Measure Center of Mass Shift.

of the inertial response of the seat by multiplication of the measured acceleration by the mass of the seat, subtraction of the calculated seat force from the measured forces to determine the forces attributable to the human response dividing the human response by the mass of the subject and then integrating the resulting subject acceleration to determine the displacement. Since this procedure involved a double integration over the period of the entire test, including both free-fall and impact, any error in the measurement was accumulated and biased the results to an unacceptable degree. This same procedure has recently been used by Yeager (ref 26) with considerably better results using the Naval Aerospace Crew Equipment Department Linear Accelerator at Philadelphia, Pennsylvania.

After concluding that the displacement of the human c. g. could not be determined within an acceptable degree of accuracy, using the AMRL Vertical Deceleration Tower, other approaches were studied. The simplest method seemed to be to measure the inertial forces exerted by the human subject during the acceleration and to develop a force or inertial response model that could be used by the escape system dynamicist within a multidegree of freedom model of the man-seat combination. The data that were collected were then analyzed by Whitmann and a mechanical analog of the test seat and human subject was developed (ref 27). The analog of the human consisted of a simple spring-mass-damper system with a natural frequency of 10 Hertz, a damping ratio of 0.3 and a mass equal to the entire mass of the test subject. This model has proven to be a good approximation of the whole body inertial forces exerted on the seat structure in the $+G_z$ direction for impact accelerations ranging from 10 to 14G.

Once a system has been designed using the inertial response model in the design process a demonstration of system performance is usually required to verify the design analysis and qualify the resulting hardware. Emergency escape systems or crash attenuation systems are generally designed to exposure limit conditions with narrow margins of safety and therefore, too hazardous to evaluate using human subjects. The approach that has been pursued by the Aerospace Medical Research Laboratory has been the development of

a mechanical surrogate or a physical analog of the human body. Such a system has been developed for the AMRL under a research contract with the Wyle Laboratories (ref 29). This "anthropodynamic dummy" was designed to meet a number of objectives listed in order of their relative priority:

- a. to duplicate the whole body inertial response characteristics in the $+G_z$ direction.
- b. to duplicate the whole body inertial response characteristics in the x-z on sagittal plane.
- c. to duplicate the center of gravity and moment of inertia of a human body.
- d. to approximate the kinematic properties of the human at the major joints providing adjustment of muscle tension.
- e. to provide a dummy with a shape similar to the human body so that a gross approximation of the aerodynamic properties could be simulated.

Figure 10 shows the basic skeletal structure of the resulting dummy. Ball joints have been used at four points within the shoulder mechanism as well as in the lower portion of the neck, in the lumbar region of the spine and the ends of the femurs. Articulation at the knees and elbows has been provided by simple pin joints. Friction dampers are used at each of the joints to provide adjustment of joint torques. Adjustment of the inertial response in the $+G_z$ direction is provided by changing the spring that represents the spinal column. Figure 11 shows the dummy in its final configuration with a solid viscoelastic material covering. Soft rubber bags that can be filled with water or soft rubber are used in the abdominal and thoracic cavities.

Impact tests of the dummy have been conducted by the authors using the Vertical Deceleration Tower to evaluate the $+G_z$ inertial response simulation. Measurements were made by placing the dummy on a rigid, cast aluminum seat pan which was connected to the seat support structure and impact carriage by three force transducers. Acceleration was also measured at the seat pan. The dummy was restrained to the seat pan by a lap belt. A shoulder harness was



Figure 10. Skeletal Structure of Physical Analog Prototype.

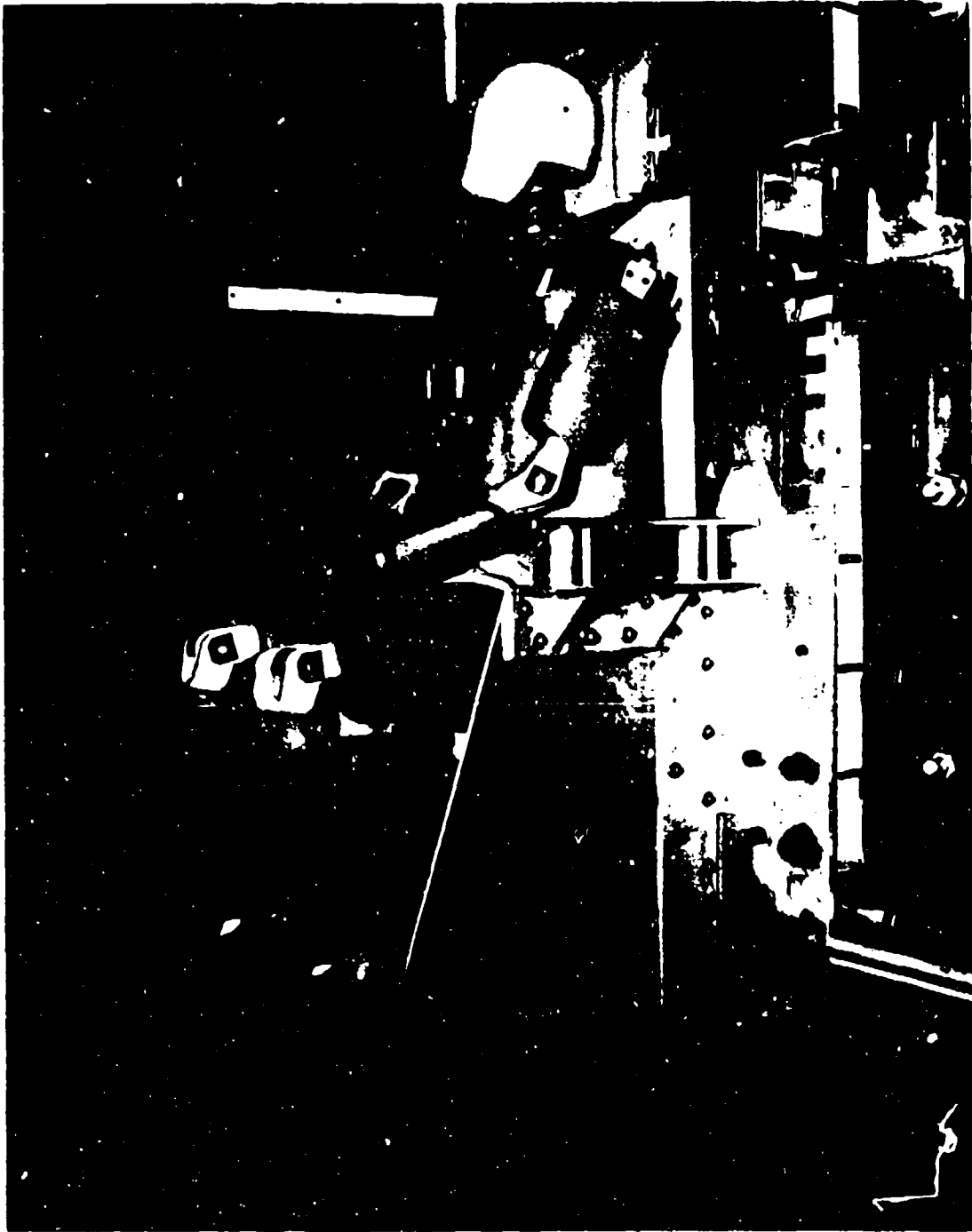
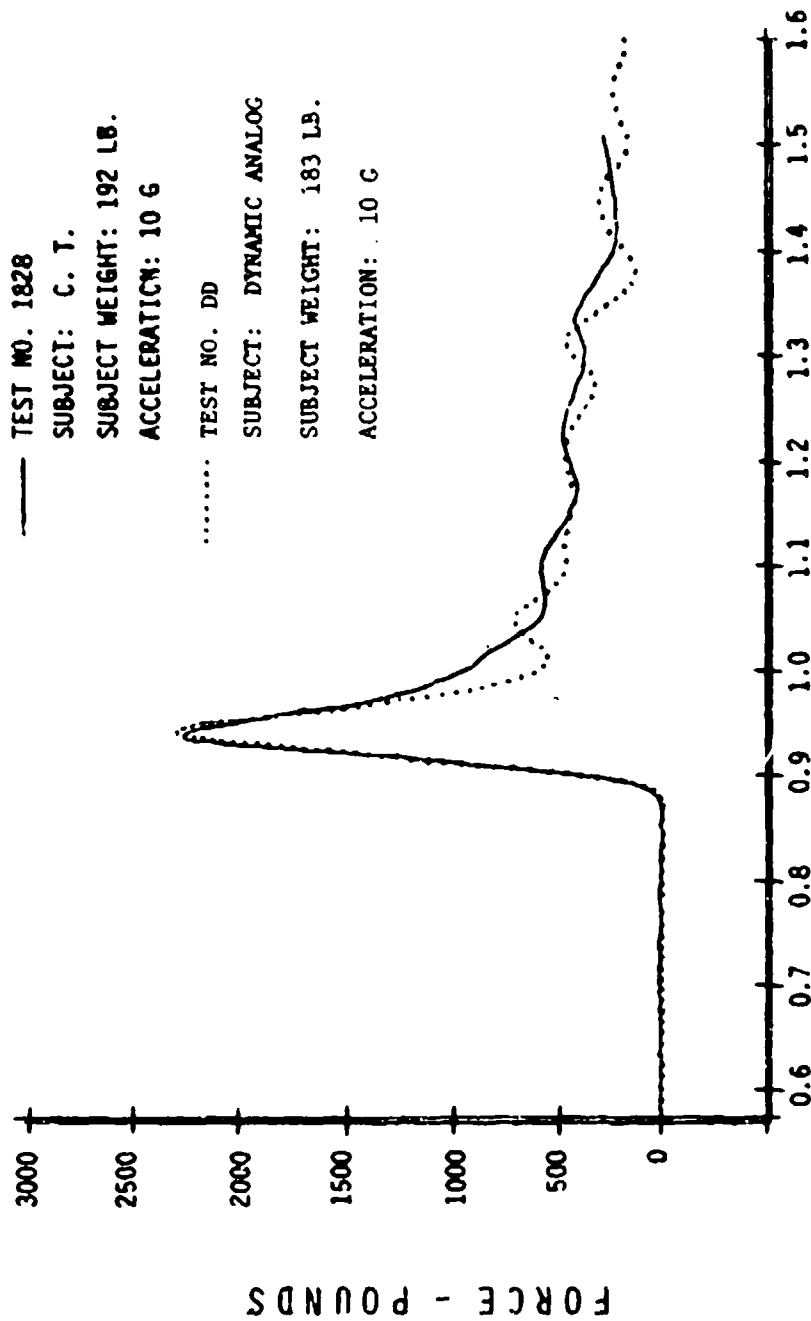

Figure 11. Final Configuration of Physical Analog Prototype.

used but was not tightened; its only function was to prevent the dummy from pitching forward out of the seat. Tests were conducted at 10G and the measured forces were compared to the same measurements taken with human subjects and another anthropomorphic dummy. The comparison of human and the prototype dummy in Figure 12 shows a very good simulation of the peak response but considerable more oscillation than the human at the end of the acceleration. The comparison of the forces measured with the conventional dummy and a human subject shown in Figure 13 dramatically illustrates the large dissimilarity that could grossly effect the performance of an escape system. Moment of inertia and center of gravity measurements were taken on the model by the Air Force Flight Dynamics Laboratory using the procedure described in reference 30. The results of these measurements shown in Figure 14 and Table I compare reasonably well with other measurements made with human subjects in similar body positions (ref 31). Additional tests to determine the $+G_x$ inertial response characteristics of the dummy prototype are forthcoming.

SUMMARY OF REQUIREMENTS

To define the design criteria required to extend the capabilities of contemporary aircraft escape systems and other protective equipment to eliminate, or at least decrease, the injury and fatality rates that have been experienced, a biodynamics research program must encompass the study of a wide range of environmental hazards that are associated with aircraft emergencies. Only a cursory review of the available design guidance and research literature is necessary to understand that the existing biodynamic information does not provide the technology base that is required to completely support a significant advancement in escape system design or crash protection equipment development. For any given stress the criteria that are provided to the designer must define the level of the stress (as a function of time) required to cause a specific injury, the probability of injury associated with the stress level, the effects of combinations of stress such as windblast and aerodynamic deceleration, the effects of sequential applications of stress as well as the effects of other



TIME FROM RELEASE - SECONDS

Figure 12. Comparison of Human and Analog Prototype Inertial Response Measurements.

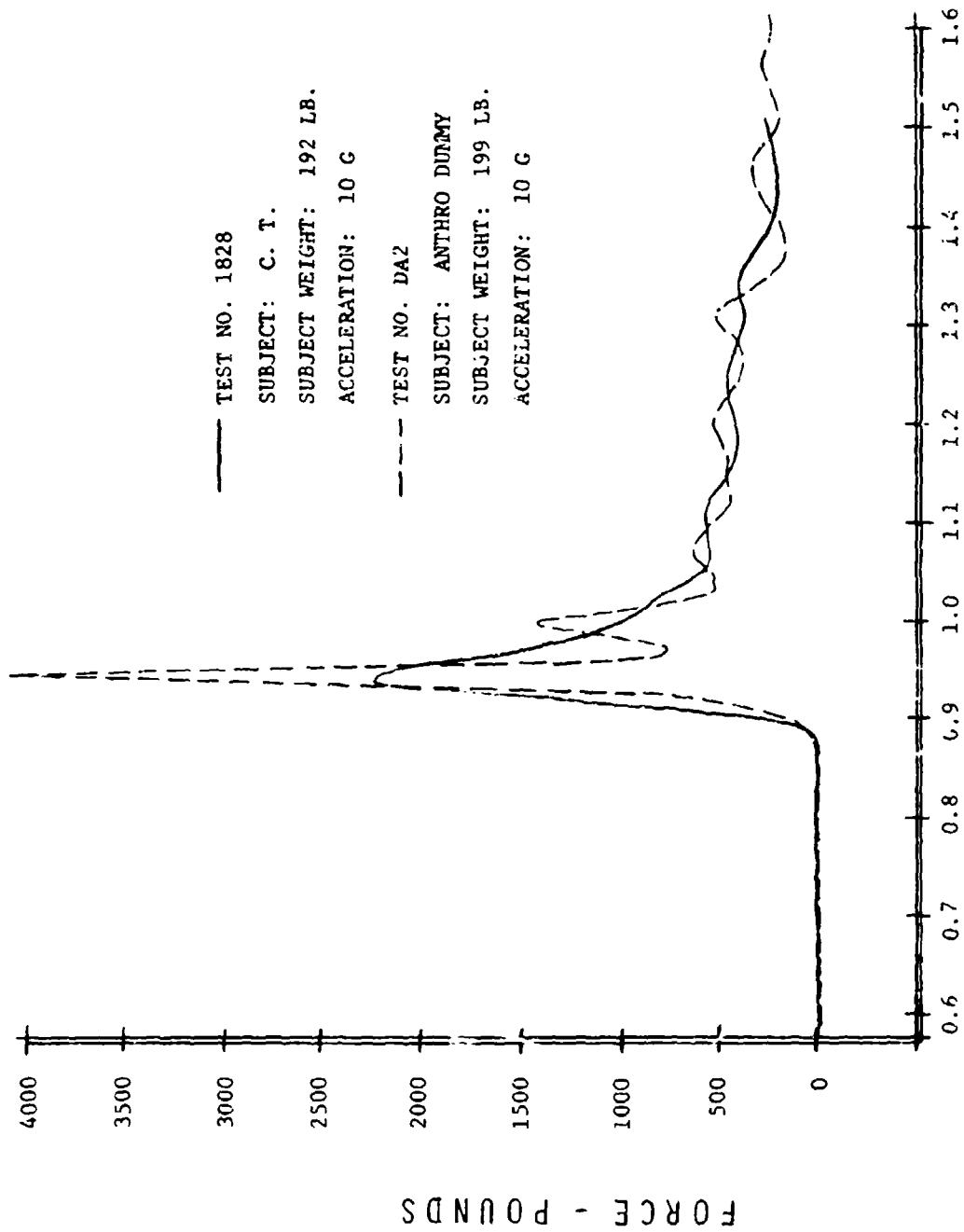

——— TEST NO. 1828
 SUBJECT: C. T.
 SUBJECT WEIGHT: 192 LB.
 ACCELERATION: 10 G

 - - - TEST NO. DA2
 SUBJECT: ANTHRO DUMMY
 SUBJECT WEIGHT: 199 LB.
 ACCELERATION: 10 G

TIME FROM RELEASE - SECONDS

Figure 13. Comparison of Conventional Dummy and Analog Prototype Response Measurements.

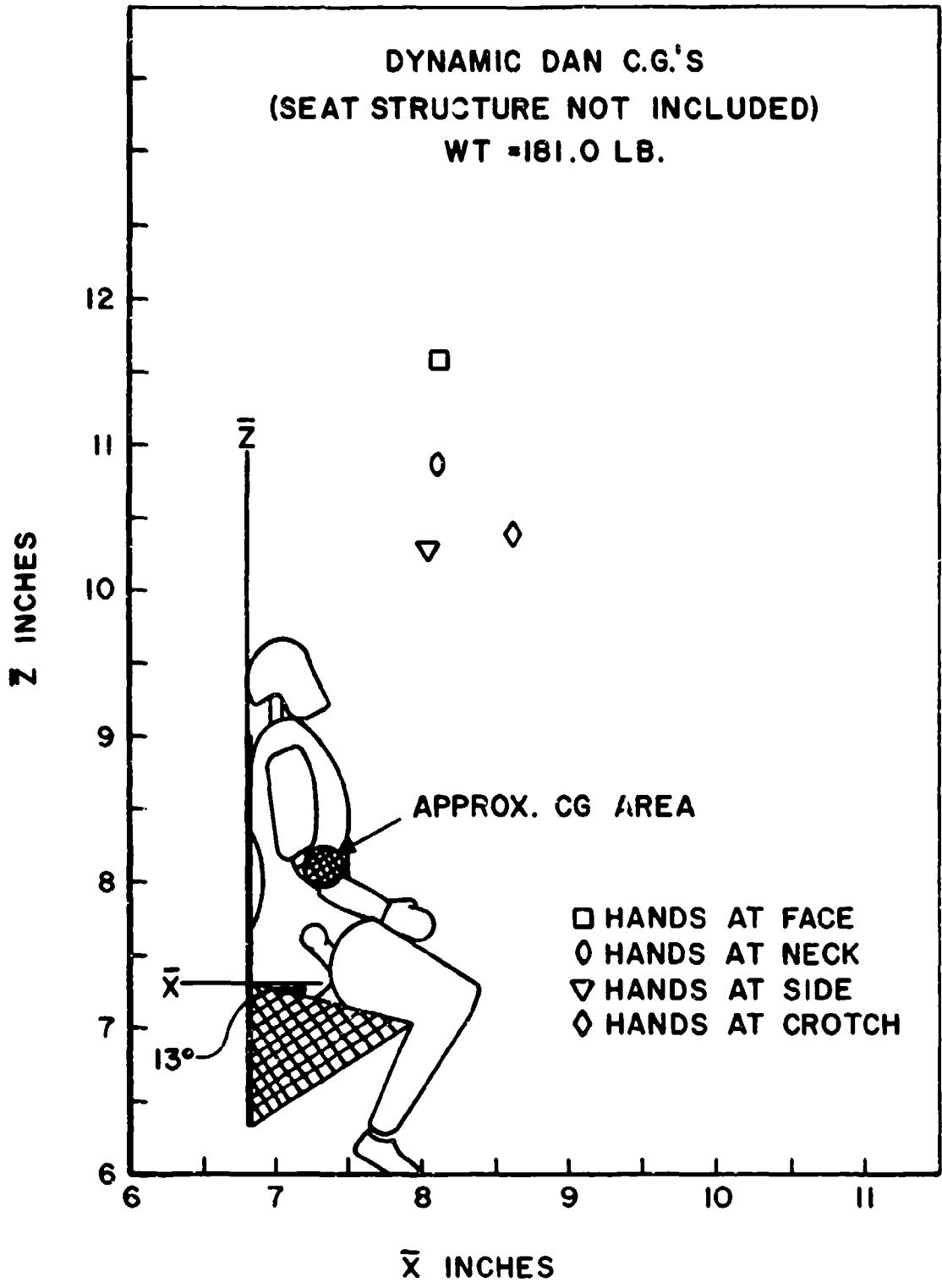

Figure 14. Positions of Center of Gravity of Analog Prototype for Four Positions.

	Weight Lbs.	I_{yy} (Pitch) 2 lb-ft-sec	I_{xx} (Roll) 2 lb-ft-sec	I_{zz} (Yaw) 2 lb-ft-sec	\bar{x} inches	\bar{y} inches	\bar{z} inches
F-106 Seat - Dynamic Dan	332.6	17.06	16.03	7.56	11.18	0.16	19.95
F-106 Seat - 95th Pct.	354.4	19.88	19.73	8.41	10.62	0.24	19.85
F-106 Seat - 5th Pct.	285.4	15.46	14.08	7.29	10.00	0.14	18.51
Dynamic Dan - Hands at Face	181.0	9.08	7.07	1.29	8.14	0.66	11.57
Dynamic Dan - Hands at Neck	181.0	7.26	5.50	1.04	8.16	0.36	10.86
Dynamic Dan - Hands at Side	181.0	7.92	5.47	0.96	8.06	0.69	10.30
Dynamic Dan - Hands at Crotch	181.0	7.94	5.66	1.00	8.64	0.49	10.39

TABLE I

variables such as crew age and conditioning, personal equipment configuration, restraint system dynamics and escape system stability. The design criteria that are available for the $+G_z$ direction represent the closest approximation to this type of comprehensive description. Although considerable research has been conducted to define the human response to the short duration acceleration environments generated during the escape sequence, only vaguely defined exposure limit criteria are available for body axes other than the $+G_z$ direction. The operationally critical modes of injury* remain to be defined for each of the other acceleration directions before any serious attempt can be made to provide more comprehensive descriptions.

More work is necessary to fully determine the effects of body support and restraint systems not only with respect to their ability to maintain body position but to the manner in which they modify the acceleration environments transmitted through them. The results of this work must be reduced to practical design and evaluation guidance. Efforts in this area have suffered from two major deficiencies. First, we have not been able to satisfactorily determine the appropriate dynamic properties of the restraint and support materials and then define their effects in a given design configuration; for example, in a specific system configuration the interplay between the properties of the webbing material, the harness geometry and elasticity of the restrained body obscure the effects of a single factor. Second, without exposure limit criteria it is impossible to evaluate the efficiency of given protection system in any way other than a comparison with other operationally acceptable systems or, in a limited fashion, by evaluation using animal subjects.

* Critical modes of injury are defined herein as those types of injuries that will limit the airman's ability to survive after ejection, prevent him from assisting in his own rescue and/or prevent him from regaining flight status soon after the ejection. From an operational as well as an economical viewpoint a practical limitation of the investigation is necessary since the study of minor injuries resulting from an emergency procedure where the alternative is usually death is certainly pointless.

As in the area of acceleration exposure limit criteria the inertial response characteristics of the human body and body segments are undefined for directions other than $+G_z$. The lack of such data not only deters the development of escape systems and impact attenuators as discussed earlier but greatly limits the designers ability to develop lightweight seat structures that will successfully withstand crash loads. Current seat design practice is to assume that the human body is a rigid mass whose load is uniformly distributed over the seating surfaces. Although this procedure is obviously inaccurate and leads to a significant structural deficiency, a correction of this practice will not be made until inertial response data are available and exist in a form that is useful to the seat designer.

The gap that exists between the designers needs and the available data has become so extensive that the most radical departure from conventional design within the last decade, the yankee extraction system design by Stanley Aviation, Inc., has been conceived and developed without such data. As a result, the limitations of this system at higher airspeeds remain undefined and may eventually be determined only by operational experience. This situation isn't too surprising since research on the windblast problem has been practically nonexistent in this country for nearly two decades. Although some action is now being taken by our Laboratory to correct this situation more emphasis will be required within the aeromedical research community to provide the necessary guidance to the designer. Initial efforts must be directed toward the definition of the aerodynamic properties of the human body and body segments. These data must be used to predict the forces acting on the crewman to initiate flailing and then verified in windtunnel tests. Only after the acquisition of such data and the development of predictive aerodynamic models can simple, objective methods of personnel protection be developed.

CONCLUSIONS

Research in biodynamics has made very significant contributions to the fulfillment of Air Force operational requirements in the area of emergency

escape system design in certain select aspects. The development of dynamic models to describe the response of the human to given environments has provided the aircraft designer with a powerful design and evaluation tool expressed in his own engineering language. Multiple degree-of-freedom models currently used to study the performance of escape systems and the effects of the design of their subsystems can be modified to incorporate the biodynamic model to assess the influence of escape system model outputs on the human. The parameters of escape system components may thereby be varied analytically to study their effect on human response and, conversely, the analysis can also show the influence of human body dynamics upon the performance of the escape system. Since the approach that has been used avoids the specification of exposure limits in absolute "safe" or "intolerable" terms it facilitates a more realistic assessment of the operational impact of a specific design and thus, allows the risk to the using population to be more commensurate with mission requirements.

The models that have been developed for use by the designer have been relatively simple systems for two important reasons. First, although much more complex models have been developed, the biological data that exist have not been adequate to verify these models. Although more complex models may eventually be capable of predicting the precise nature and extent of an injury, in most Air Force design applications such precision is usually of only academic interest. Second, to be useful tools the biodynamic models must be relatively simple to avoid introducing an unreasonable complexity to the overall escape system-man simulation or implying by their complexity a degree of accuracy that is not actually provided or, for that matter, even required in such design analysis calculations.

The scope of development and application of biodynamic models is extensive in the area of escape system design and practically limitless when other applications such as the field of transportation safety are considered. The primary limitation to the extension of their usefulness and the incorporation of the large inventory of modeling techniques that are available from other fields of science and engineering is the availability of meaningful experimental data.

REFERENCES

1. Brinkley, J. W., "Development of Aerospace Escape Systems," Air University Review, Vol. XIX, No. 5, pp. 34-49, July - August 1968.
2. Shannon, R. H., "Operational Aspects of Forces on Man During Ejection/Extraction Escape in the U. S. Air Force 1 Jan 1968 - 31 Dec 1970," Linear Acceleration (Impact Type), AGARD Conference Preprint No. 88, Harford House, London, June 1971.
3. Military Specification. Seat System: Upward Ejection, Aircraft, General Specification for. MIL-S-9479A (USAF), 16 June 1967.
4. Military Specification. Capsule Emergency Escape Systems, General Requirements for. MIL-C-25969B (USAF).
5. Payne, P. R., "The Dynamics of Human Restraint Systems," Impact Acceleration Stress, National Academy of Sciences-National Research Council, Publication 977, Washington, D. C., 1962.
6. Stech, E. C. and P. R. Payne, Dynamic Models of the Human Body, AMRL-TR-66-157, Aerospace Medical Research Laboratory, Wright-Patterson Air Force Base, Ohio, AD 701 383, November 1969.
7. Coermann, R. R., The Mechanical Impedance of the Human Body in Sitting and Standing Positions at Low Frequencies, ASD Technical Report 61-492, Aerospace Medical Research Laboratory, Wright-Patterson Air Force Base, Ohio, AD 413 478, September 1961.
8. Hertzberg, H. T. E., G. S. Daniels and E. Churchill, Anthropometry of Flying Personnel -1950, WADC Technical Report 52-321, Wright Air Development Center, Wright-Patterson Air Force Base, Ohio, AD 47 953, April 1959.
9. Chubb, R. M., W. R. Detrick and R. N. Shannon, Compression Fracture of the Spine During USAF Ejections, Report No. 3-66, Deputy Inspector General for Inspection and Safety, Norton Air Force Base, California, 21 April 1965.
10. Volck, W., Applied Statistics for Engineers, McGraw-Hill Book Company, Inc., New York, 1958.
11. Carr, R. W. and N. S. Phillips, Definition of Design Criteria for Energy Absorption Systems, NADC-AC-7010, Naval Air Engineering Center, Philadelphia, Pennsylvania, AD 871 040, June 1970.

12. Payne, P. R., Personnel Restraint and Support System Dynamics, AMRL-TR-65-127, Aerospace Medical Research Laboratory, Wright-Patterson Air Force Base, Ohio, AD 624 487, October 1965.
13. Payne, P. R., "Injury Potential of Ejection Seat Cushions," Journal of Aircraft, Vol. 6, No. 3, pp. 273-278, May-June 1969; also published as AMRL-TR-69-134.
14. Mohr, G. C., J. W. Brinkley, L. E. Kazarian and W. W. Millard, "Variations of Spinal Alignment in Egress Systems," Aerospace Medicine, Vol. 40, No. 9, pp. 983-988, September 1969; also published as AMRL-TR-67-232.
15. Martin, J., Report on Research and Development Carried Out by Martin-Baker Aircraft Co., Ltd., in Connection with Ejection Seats for High Speed Aircraft, Martin-Baker Aircraft Company, Ltd., England.
16. Latham, F., "A Study in Body Ballistics: Seat Ejection," Proceedings of the Royal Society of London, Series B-Biological Sciences, Vol. 147, pp. 121-139, December 1957.
17. Bosee, R. A. and C. F. Payne, "Theory on the Mechanism of Vertebral Injuries Sustained on Ejections From Aircraft," Presented at the meeting of the Aerospace Medical Panel of the Advisory Group for Aeronautical Research and Development, North American Treaty Organization (NATO), April 1961.
18. Kazarian, L. E., D. D. Boyd and H. E. von Gierke, "The Dynamic Biomechanical Nature of Spinal Fractures and Articular Facet Derangement," Linear Acceleration (Impact Type), AGARD Conference Preprint No. 88, Harford House, London, June 1971; also published as AMRL-TR-71-17.
19. Brinkley, J. W. and G. C. Mohr, Presentation to Headquarters USAF Air Staff personnel, Pentagon, Washington, D. C., 26 October 1966.
20. Shannon, R. N., Written communication.
21. Coermann, R. R., "Comparison of the Dynamic Characteristics of Dummies, Animals and Man," Impact Acceleration Stress, Publication 977, National Academy of Sciences-National Research Council, Washington, D. C., 1962.
22. Douglas Aircraft Company, Report No. LB 32116, February 1965.
23. Horne, G. B. and J. J. McDonnell, Studies to Determine Dynamic Displacement of Seat/Man Center of Gravity Due to Rocket Thrust, NAEC-ACEL-531, U. S. Naval Air Engineering Center, Philadelphia, Pennsylvania, 30 July 1965.

24. Brinkley, J. W., E. B. Weis, P. J. Martin and N. P. Clarke, Shift of the Center of Mass of a Man-Seat System During Transient Acceleration, Presented at the 35th Annual Scientific Meeting of the Aerospace Medical Association, 11-14 May 1964.
25. Weis, E. B., and F. P. Priamano, The Motion of the Human Center of Mass and Its Relationship to the Mechanical Impedance, AMRL-TR-65-50, Aerospace Medical Research Laboratory, Wright-Patterson Air Force Base, Ohio, AD 637 182, June 1966.
26. Yeager, R. R., Transient Deviations of the Human Body's Center of Mass, Report No. NADC-AC-7012, Naval Air Development Center, Johnsville, Warminster, Pennsylvania, October 1970.
27. Whittmann, T. J., An Analytical Model to Duplicate Human Dynamic Force Response to Impact, ASME Publication 66-WA/BHF-12 and AMRL Technical Report 66-126, Aerospace Medical Research Laboratory, Wright-Patterson Air Force Base, Ohio, AD 724 544, November 1966.
28. Payne, P. R. and E. G. U. Band, Development of a Dynamic Analog Anthropomorphic Dummy for Aircraft Escape System Testing, AMRL-TR-70-10, Aerospace Medical Research Laboratory, Wright-Patterson Air Force Base, Ohio, August 1971.
29. Winstandley, W. C., T. J. Whittmann and M. C. Eifert, Special Equipment for Measurement of Mechanical Dynamic Properties of Emergency Escape Systems, AFFDL-TR-68-8, Air Force Flight Dynamics Laboratory, Wright-Patterson Air Force Base, Ohio, January 1968.
30. Santschi, W. R., J. DuBois and C. Omoto, Moments of Inertia and Centers of Gravity of the Living Human Body, AMRL-TDR-63-36, Aerospace Medical Research Laboratory, Wright-Patterson Air Force Base, Ohio, AD 410 451, May 1963.