

AD 740469

Aerospace Medical Research Laboratory  
Aerospace Medical Div, Air Force Systems Command  
Wright-Patterson Air Force Base, Ohio 45433

SECURITY CLASSIFICATION

Unclassified

20. GROUP

N/A

1

3. REPORT TITLE

THE USE OF MODELS IN THE STUDY OF WOUND BALLISTICS.

4. DESCRIPTIVE NOTES (Type of report and inclusive dates)

5. AUTHOR(S) (First name, middle initial, last name)

A. A. Woodward

6. REPORT DATE

December 1971

7a. TOTAL NO. OF PAGES

~~16~~ 16

7b. NO. OF REFS

5

8a. CONTRACT OR GRANT NO.

A. PROJECT NO. 7231

9a. ORIGINATOR'S REPORT NUMBER(S)

AMRL-TR-71-29  
Paper No. 32

9b. OTHER REPORT NO(S) (Any other numbers that may be assigned to this report)

10. DISTRIBUTION STATEMENT

Approved for public release; distribution unlimited

11. SUPPLEMENTARY NOTES

12. SPONSORING MILITARY ACTIVITY

Aerospace Medical Research Laboratory  
Aerospace Medical Div, Air Force Systems  
Command, Wright-Patterson AFB, OH 45433

13. ABSTRACT

The Symposium on Biodynamics Models and Their Applications took place in Dayton, Ohio, on 26-28 October 1970 under the sponsorship of the National Academy of Sciences - National Research Council, Committee on Hearing, Bioacoustics, and Biomechanics; the National Aeronautics and Space Administration; and the Aerospace Medical Research Laboratory, Aerospace Medical Division, United States Air Force. Most technical areas discussed included application of biodynamic models for the establishment of environmental exposure limits, models for interpretation of animal, dummy, and operational experiments, mechanical characterization of living tissue and isolated organs, models to describe man's response to impact, blast, and acoustic energy, and performance in biodynamic environments.

Details of illustrations in  
this document may be better  
studied on microfiche

Reproduced from  
best available copy.

DDC  
RECEIVED  
APR 26 1972  
B

DD FORM 1 NOV 68 1473

Reproduced by  
NATIONAL TECHNICAL  
INFORMATION SERVICE  
Springfield, Va. 22151

Security Classification

PAPER NO. 32

THE USE OF MODELS IN THE STUDY OF WOUND BALLISTICS

A. A. WOODWARD

Ballistic Research Laboratories  
U.S. Army Aberdeen Research and Development Center  
Aberdeen Proving Ground, Maryland

ABSTRACT

An overall description is presented of some of the characteristics of a new generalized wound ballistics model that is in the process of development. The model is probabilistic, and it is being formulated so as to allow evolving modifications as improved input data become available or new requirements put on the type of outputs desired. Included are descriptions of a number of modeling methods that are used to generate input data for the generalized model; among these are physical, biological, and mathematical models.

DISCUSSION

The science of military ballistics deals with the entire phenomenal history of a weapon projectile, beginning with its launching and ending when its effects have been exerted on a target. Our branch of science, wound ballistics, focuses on the effects of weaponry on one specific very complex target, the human body. In brief, we are concerned with casualties, how they are produced, the effectiveness of different weapons (ours and the enemy's) in producing them, and their effects on the military capabilities of men. Ultimately our function is to make predictions of the numbers, types and severity of casualties anticipated among men in combat and of effects of casualties sustained on the ability of the men to accomplish military missions.

Modeling techniques of different kinds are peculiarly useful, and often necessary, tools to us for two primary reasons. On one hand, like others participating in this Symposium, we cannot conduct direct experiments on the phenomena of primary interest to us, the mechanisms of injury production in and the effects of injuries on the functions of

the human body. Modeling methods make possible indirect approaches to the quantitative study of these phenomena. On the other hand, we must deal often with complex multivariant problems: e.g., estimation of casualties of all types, and of their effects, to be expected among soldiers in groups of different sizes performing different kinds of tasks concurrently and in sequence under all kinds of combat conditions while exposed to varying mixes of weaponry. Problems of this kind can be handled by appropriate mathematical models that are practical if one has accumulated sufficient input data and enjoys the support of modern sophisticated computer facilities. At this point one notes that in the discussion that follows the work described is the result of a group effort for which the present author is acting as a reporter.

As a framework within which to discuss some of the ways in which we utilize modeling methods, we may select our currently most significant effort, the development of a completely generalized wound ballistics model. Figure 1 illustrates how the anti-personnel action of a weapon may be analyzed as a multi-stage causal sequence.<sup>1</sup> In this figure the blocks indicate end-points of assessment stages, which are indicated by the connecting arrows. The blocks in this diagram are conceptually important, since they constitute isolating interfaces between assessment methods that are qualitatively different. In addition they represent real observable stages, the transitions between which a useful model must express mathematically. However, the bulk of the effort required to develop a model in working form capable of yielding quantitative evaluations must be spent on the assessment stages.

As a result of the conceptual independence of the assessment stages, research efforts to accumulate data and to develop mathematical formulations defining them can proceed concurrently. Moreover, even though the best available knowledge and methods vary considerably from stage to stage, a model can be designed so that it becomes immediately useful as soon as acceptable formulations are available for each assessment stage. Set up in this manner, the model retains the important characteristic of evolutionary capability; as better assessment techniques become available, they can be substituted for those initially utilized without basic modifications or re-design of the model. These features are lacking in wound ballistics models in current use.

Figure 2 shows part of the same scheme with addition of details on the end-point stages. We can use this to examine how we use specific modeling techniques to solve particular problems only generally inferred above. The Wounding Mechanism block lists the primary means by which contemporary anti-personnel weapons cause damage to living tissue. Any particular weapon may involve only one or any combination of these mechanisms. A high velocity bullet, for example, passes violently through tissues, slowing down as it loses kinetic

energy as a result of the resistance presented by the tissues. In its wake a discrete hole remains, a wound tract of completely destroyed and disintegrated tissue; in addition (as we shall see shortly) it causes a considerable amount of damage at a distance in tissues not directly hit by the passing missile. Because tissues (e.g., bone, muscle, lung) vary in penetrability, the missile will lose kinetic energy at different rates in passing through them, leaving a wound tract of varying cross section area. Since the physical parameters of the missile at the moment of impact can be exactly measured, it is desirable to use energetics as the basis of the trauma (damage producing) assessment stage. This can be done if some measurable characteristic of the damaged tissues can be found that is quantitatively relatable to the energetics of the penetrating missile. The volume of the permanent wound tract is a useful, if less than perfect, measure that is used to give an objective assessment procedure. The wound tract volume, incidentally, thus becomes a conceptual model of damage that permits bypassing of the impossible tasks of analyzing cell by cell the physical events occurring during the actual process of tissue destruction.

The next assessment stage, Medical Assessment, is not now amenable to objective treatment because of the complexity of body architecture and the functional interdependence of its component organs and tissues. The best procedure we can use, in order to let the general model become functional, is to submit descriptions of wound tracts to especially qualified medical assessors and accept their best judgment as the basis for establishing estimates of severity of injury to damaged organic subsystems.

Actual wound tracts in human tissues caused by missiles of known energetics are too rarely available for study, so we resort to one of the simplest models to study penetration phenomena. Missiles of any kind can be fired through blocks of 20 percent gelatin, which has the same density and water content as average human tissues. As a tissue model it is reproducible, inexpensive, and transparent. Figure 3 shows a series of photographs, taken by very high speed photographic techniques of a single high velocity bullet passing through such a block.<sup>2</sup> From such photographs one can make measurements from which equations can be derived for retardation, penetration depth, loss in kinetic energy, etc., that can be used to compare the behavior of any kind of missile impacting at any energetic level. In addition, such phenomena as the effects of yaw and tumbling can be observed and measured. Well illustrated is the phenomenon of cavitation produced by high velocity missiles, in which a large temporary cavity is formed, collapses, and reforms for several cycles: This is the process responsible for tissue damage at a distance from the path of the passing missile, and one can readily understand from this picture some of the problems of estimating quantitatively the degree of damage in a tissue from the permanent wound tract alone.

Although 20 percent gelatin is an adequate model for comparative studies, it differs considerably in microstructure and physical properties of some sorts from any particular real tissue. For this reason it is desirable to make firings through real tissues under controlled firing conditions to get data through which the effects of missile penetration through tissues can be related to more abundant data derived from gelatin block models. For this purpose isolated animal tissues may be used. These become highly specialized models for the study of injury in the human tissues that we cannot study directly.

After sufficient data has been made available from studies as those described above, so that generalized quantitative statements can be formulated, it is possible to use these in a much more sophisticated type of model. One such is the Computer Man Program.<sup>3</sup> Figure 4 is a diagrammatic representation of the anatomical basis for this program. Using the plates of an atlas of cross-sectional anatomy,<sup>4</sup> a given transverse section through an actual human body is subdivided into elements 5 mm. square. Each section is assigned a code reflecting the dominant tissue type contained within. Figure 4 shows the resulting geometric transform. With tissue code and location for each of the elements in the reduced human body form illustrated. Figure 5 is a computer print-out of the same section derived from this program. The program is entered with various input data, such as retardation values for each tissue element, the mass, velocity, and striking angle of an impacting missile of interest, and values for minimum velocity for damage for each tissue type. Then the program can compute penetration paths and depths for any number of random hits from any direction, identifying the tissues identified along the way. In its present form the program proceeds to predict incapacitations within the context of the deterministic wound ballistics model now in use. The program can produce still other types of output, such as probability that a random hit will perforate the whole body at any level hit or that a random hit will strike any particular organ or tissue. Given further input data on the retardation produced by armor materials, it will yield penetration and incapacitation outputs for areas of the body covered by personnel armor. The program is readily adaptable to the new generalized wound ballistics model. Further, it is being updated through acquisition of new sets of body sections more nearly representative of the dimensions of the military population. These will allow the program to take into account variation in body sizes in terms of percentiles of the military population, based on a recent (1966) survey of the anthropometrics of Army personnel.

Figure 6 shows the details of the later stages in the casualty sequence. Let us consider the problems of performance evaluation. Granted any combination of dysfunctions (loss of a hand, of 5 percent of the circulating blood, of hearing in one ear) resulting from injury, how does one assess the resultant decrement in the ability

5

of the injured man to perform necessary tasks (defined as relatively short sequences of motions)? There is a large body of information on task performance of injured men (industrial workers, athletes, disabled veterans), almost none of which is applicable to the problem of the wounded soldier in combat. If for no other reason, this data is largely invalid because the observations were made on men after they had recovered from the injury to some extent, and had undergone considerable learning in the process. We are concerned with the soldier's ability to perform immediately after injury and during short following intervals. The first step is to simplify the problem; of all the possible things a healthy man can possibly do, a relatively small number of them can account for most of what a soldier is called on to do during the course of combat. This kind of reduction has been done for the case of the foot soldier in the course of development of a Combat Effectiveness Test Facility at Ft. Lee, Virginia,<sup>5</sup> based on interviews with veterans in combat during the three most recent wars. Nearly all of the tasks in the catalogue thus produced have been incorporated into a series of courses provided with a largely automated measuring instrumentation system. The course was designed to test whether individual equipment items (weapons, clothing, etc.) caused any degradation in performance.

We have recently finished a series of pilot studies in which the facility is used in a different way, illustrated in Figure 7. The soldier is in the process of shoveling 1400 lbs. of sand from a concrete pit into a hopper suspended from a load cell, which provides measures of the time required to move successive increments of sand. Two kinds of modeling are illustrated. The task condition is a model of the more familiar task of using an entrenching tool to dig a fox hole, modified in order to provide more reliability and sensitivity of measurement than can be achieved in the digging of actual fox holes. The component courses of the whole test facility are arrays of other types of task modeling; and the entire facility, which takes about 7 hours to run completely and involves about 20 miles of walking, is intended to model a sequence and difficulty of tasks that might be encountered during a day of combat.

In this same photograph one can see that the soldier is restrained by a simple device that denies him the use of his preferred arm (he was right-handed), and the awkwardness of his tool handling is easily observed. We have used a number of such devices, which enable us to use an uninjured man as a model of a man wounded in several ways. The model is imperfect in that it simulates only one aspect of injury, the actual loss of a bodily capability. We are in the process of building up a battery of techniques which can be used to explore other aspects of wound injuries, hoping that the combined results of several such methods will allow us more closely evaluate the effects of actual injury. To our knowledge this has not been attempted in a systematic manner previously under controlled conditions.

We have not yet mentioned one significant characteristic of the new overall wound model we are developing. Most of the models under discussion at this Symposium are almost certainly deterministic in nature; i.e., they deal with a sequence of events related temporarily and causally. Our model is to be wholly probabilistic. Randomness operates widely in the case of a soldier in combat. Whether a man will be hit at all, by what kind of weapon, whether any particular organ is damaged and to what degree, the effects of multiple wounds on ability to perform - all of these are governed by randomness with respect to him. A deterministic model can deal with such problems only by tediously working through large numbers of sequences which have to be reprogrammed as variables are altered in order. Given the proper design and input data, a probabilistic model deals directly with randomness. Figure 8 shows a diagram of the logic of a probabilistic model for evaluation of one type of weapon only - a kinetic energy missile (such as a bullet or a grenade fragment).<sup>6</sup> Seemingly complicated, this schema is made up of a number of YES-NO decisions, with probabilities assigned to each pair of decision alternates. These probabilities themselves can be derived from proper computer processing of data derived from deterministic experimental observations. This yields a model that is conceptually a bit complicated, but essentially simple mathematically. The final predictive output consists essentially of the combined probabilities of all the decision elements in the model. It is in this form that we can best use casualty predictions, for our problems involve populations rather than individuals. This is still not the main reason for selecting a probabilistic basis for a generalized wound ballistic model. The reason was mentioned earlier. As better data becomes available from improved assessment methodologies, we can continually evolve an improved model or adapt it to new types of problems by merely inserting into a computer program revised probability data without basically redesigning the entire model.

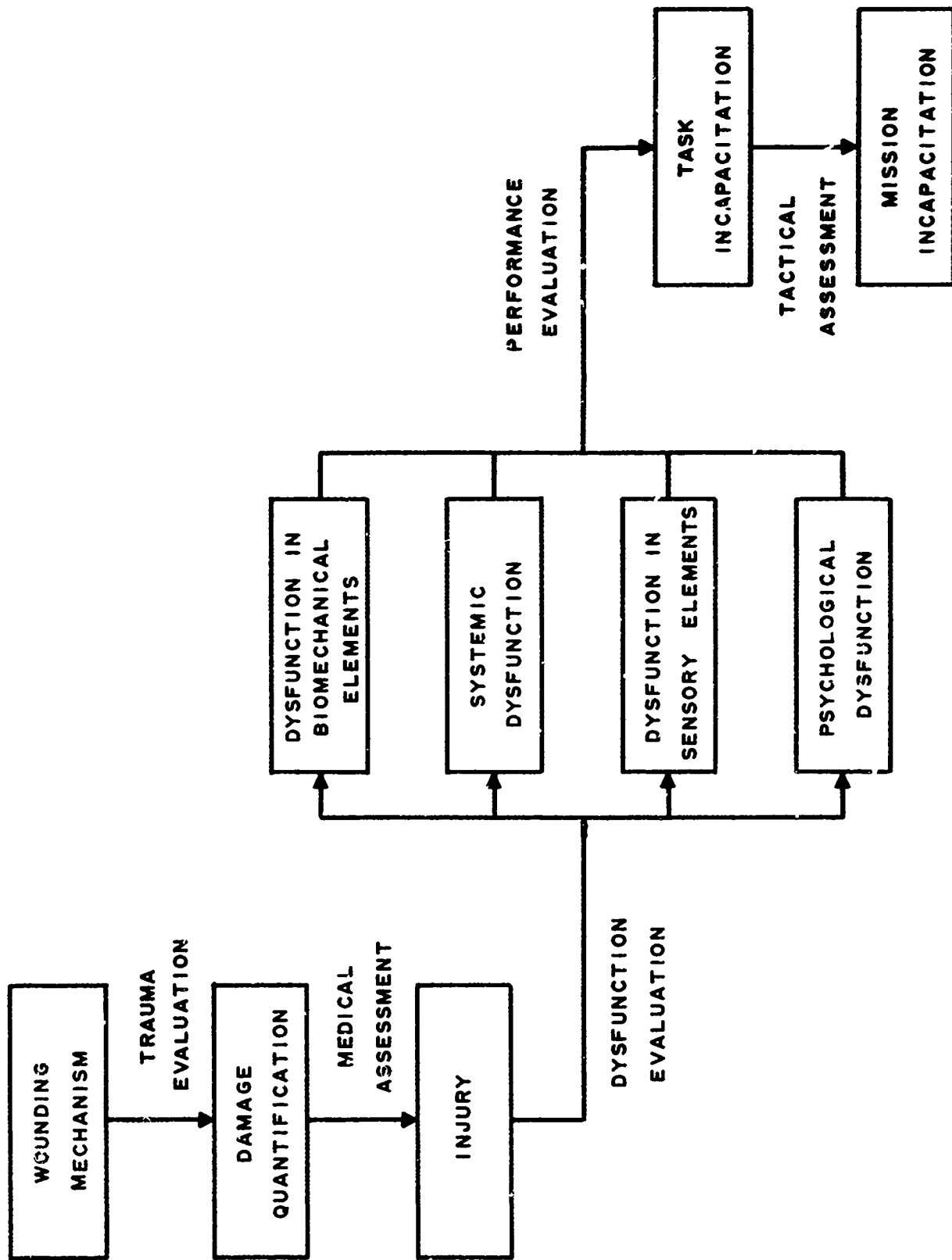

Figure 1. Block diagram of the new wound ballistic model.

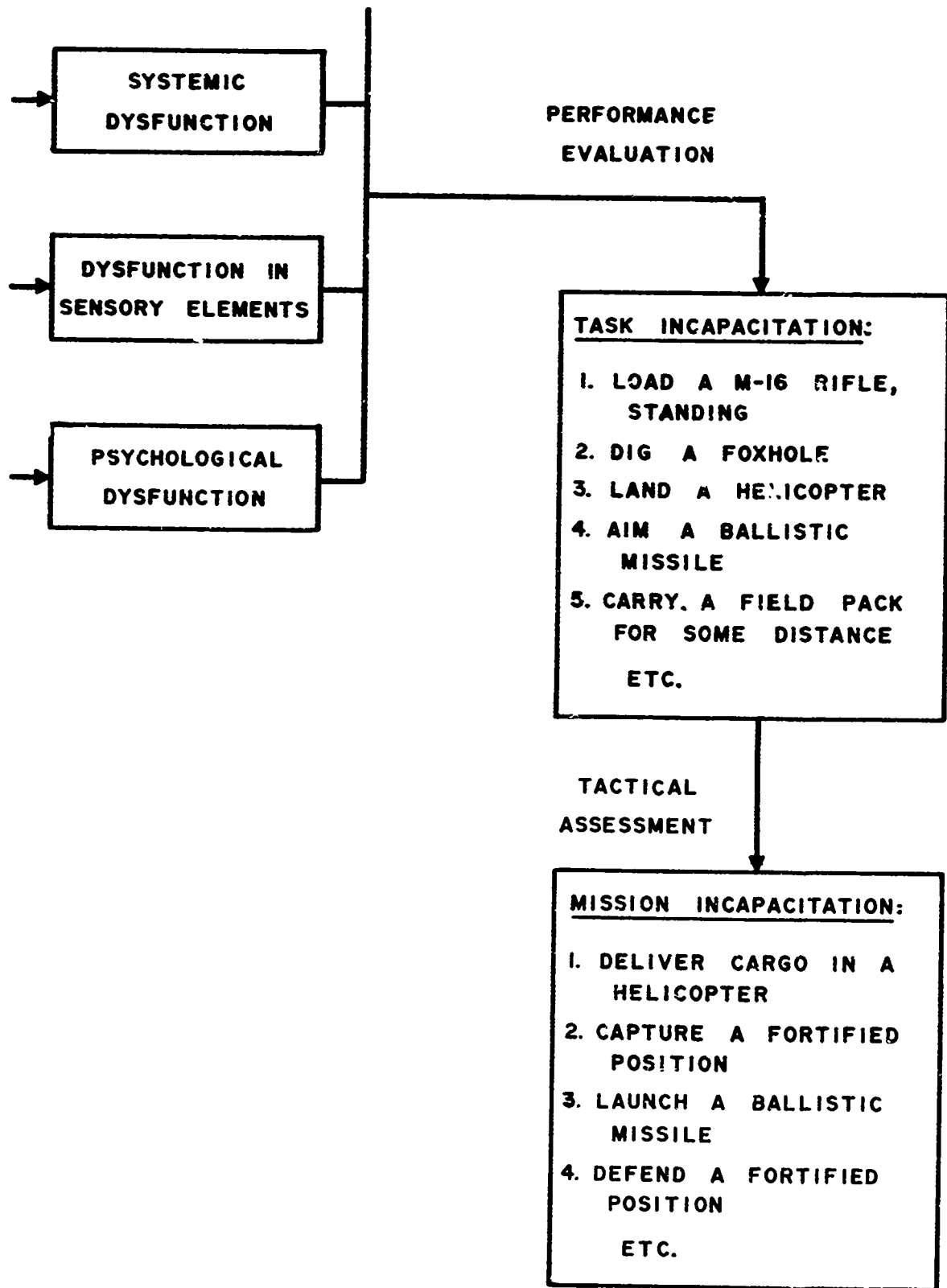

Figure 2. Examples of end-point definitions in the initial stages of the new wound ballistics model.

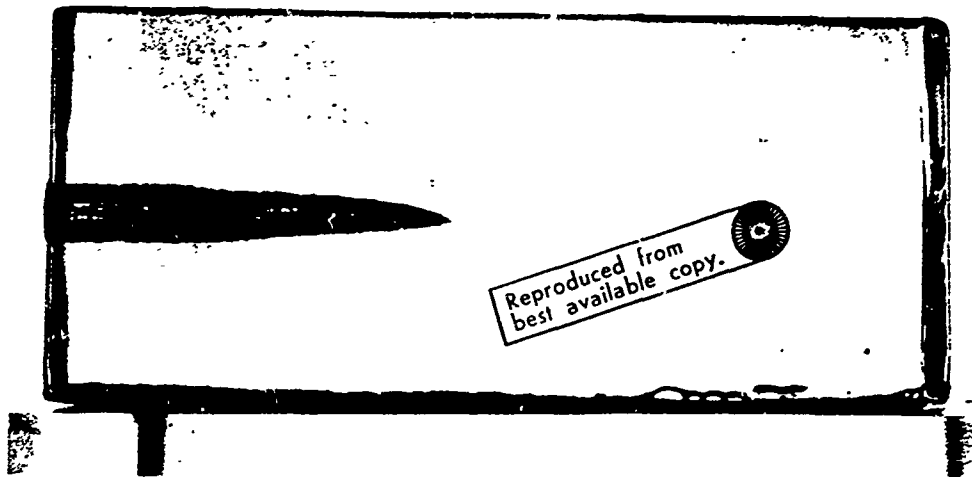
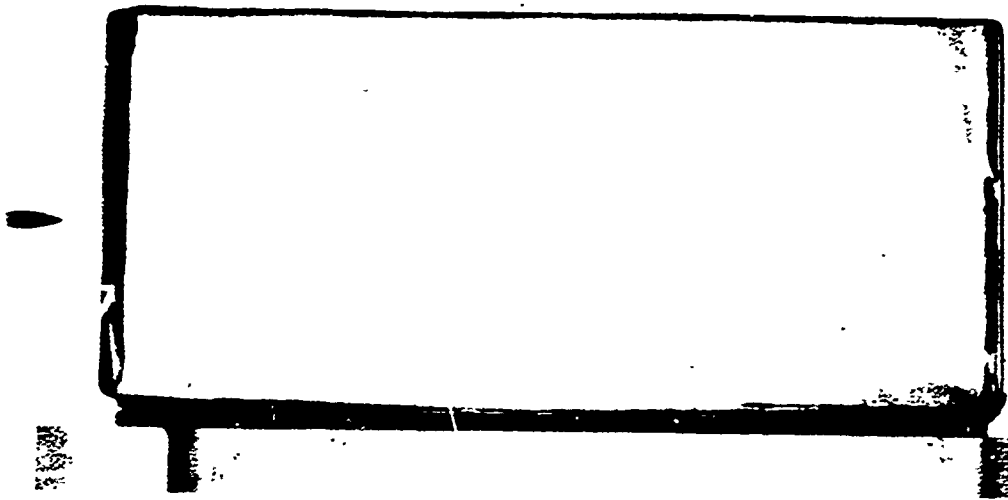

Figure 3. Series of high speed visible light photographs of a single bullet passing through a gelatin block.

# THE COMPUTER MAN

## CROSS SECTION #28

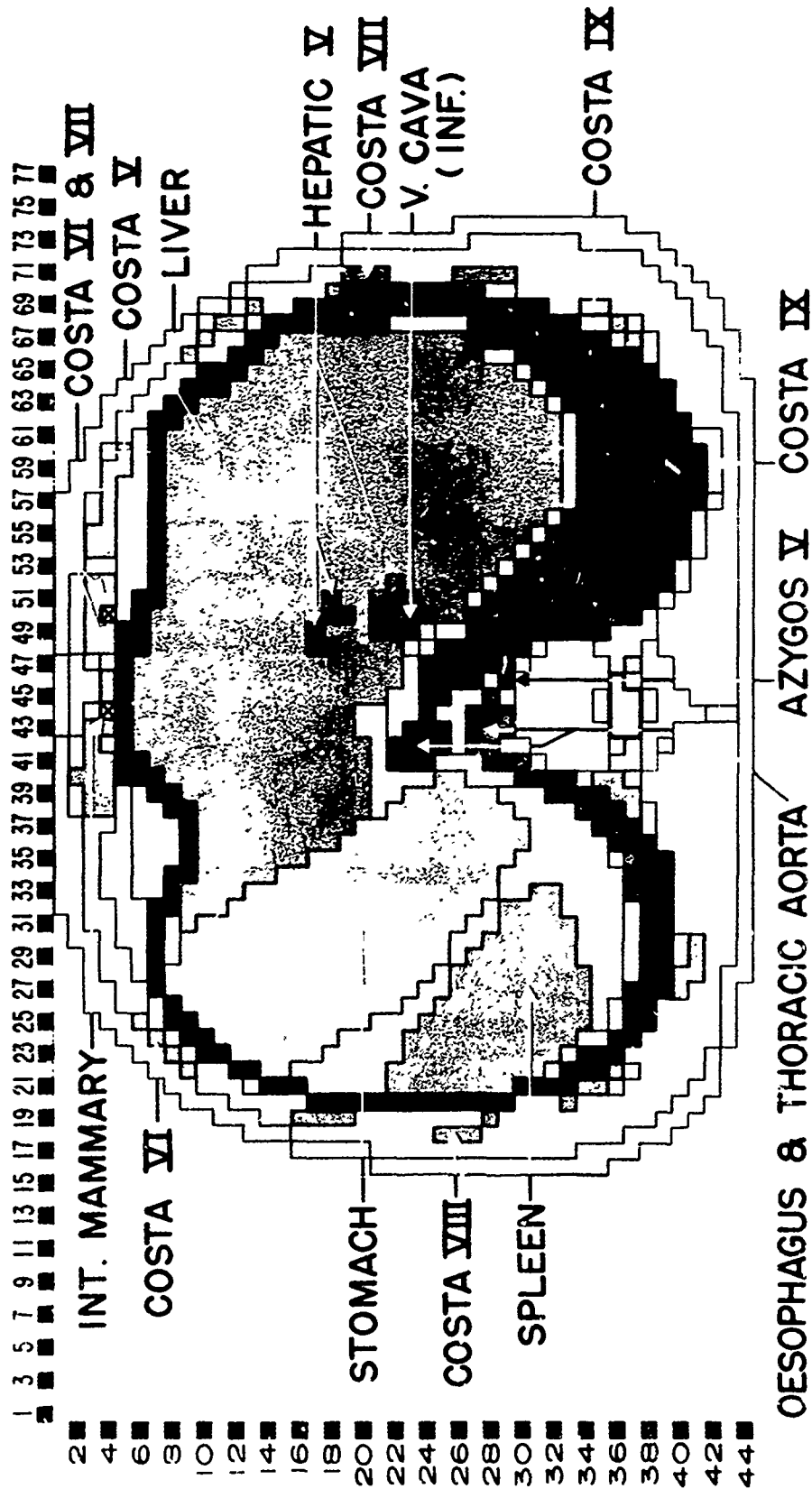

Figure 4. The Computer Man: Diagram of the breakdown of a single human body section into 5 mm. square elements given a single tissue identification.



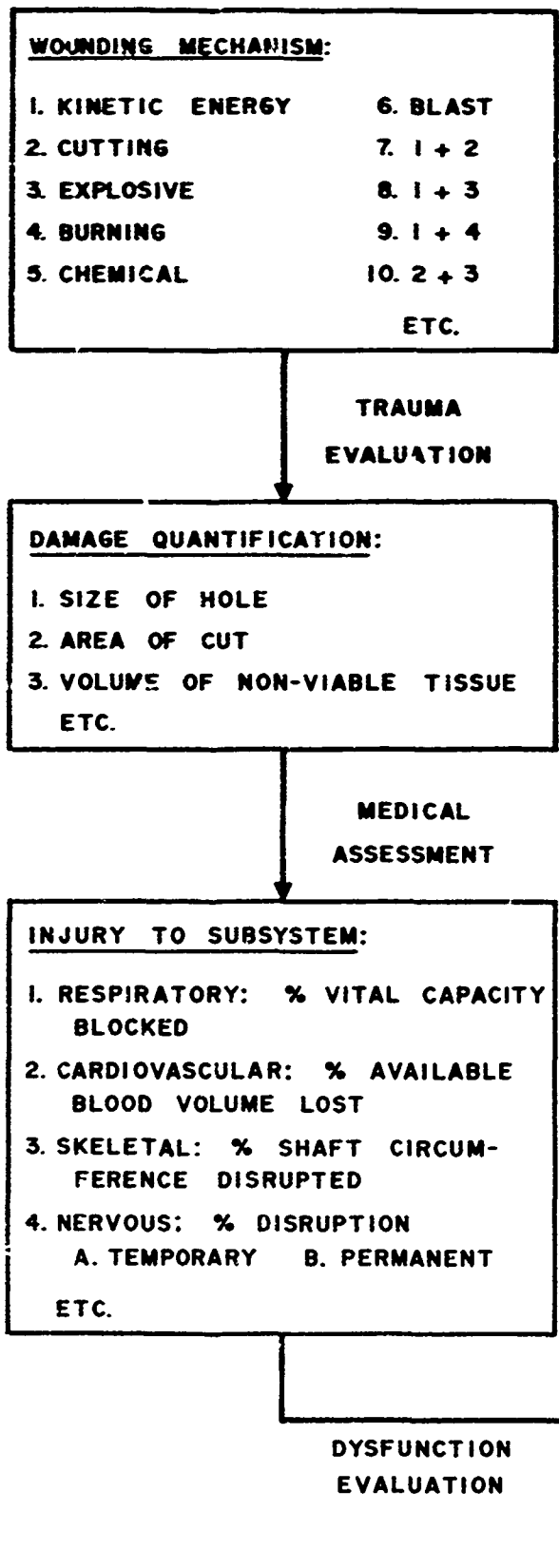

Figure 6. Soldier working at the Hasty Fighting Position course of the Combat Effectiveness Test Facility with one arm completely restrained.



Figure 7. Examples of end-point definitions in the last stages of the new wound ballistics model.

LOGIC FOR DETERMINING THE PROBABILITY OF INCAPACITATING  
A SOLDIER SUBJECTED TO A BATTLEFIELD THREAT

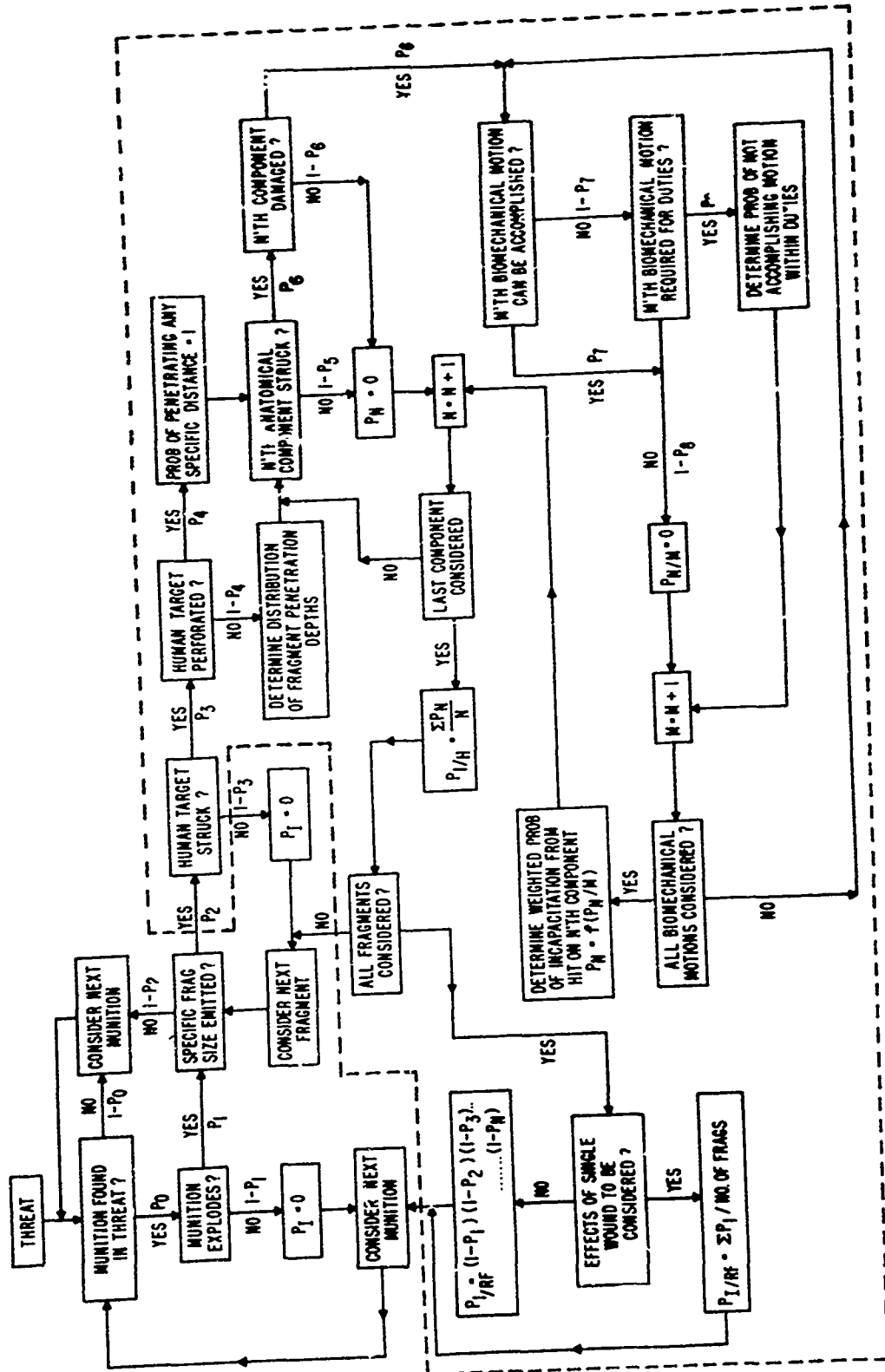

Figure 8. Logic diagram for probabilistic model of incapacitation by kinetic energy missiles.

REFERENCES

1. Sturdivan, L.M., Clare, V.R., and Amato, J. J. "New Wound Ballistics Model." Unpublished study paper by joint Committee on New Wound Ballistics Model, Ballistic Research Laboratories, Aberdeen Proving Ground, Maryland and Edgewood Arsenal, Maryland, 1970.
2. High speed photographs taken by Photographic Section, Biophysics Laboratory, Edgewood Arsenal, Maryland 1969.
3. Johnson, W.P., Brown, A., and Kindred, F. A. "Proportions of the Anatomical Components of the Wound Ballistics Computer Man." Ballistic Research Laboratories Memorandum Report No. 1907, March, 1968.
4. Eycleshymer, A.C., and Scjoemaker, D.M. "A Cross-Section Anatomy." New York, 1911.
5. "Development of Methodology for Measuring Effects of Personal Clothing and Equipment on Combat Effectiveness of the Field Soldier." Phase III, Final Report. USATECOM Project Number 803077000-01E. USAGETA, Ft. Lee, Virginia, December 1967.