

AFCRL - 72-0208

740638

INSTRUCTION MANUAL
EG&G Model 196
AIRCRAFT HYGROMETER SYSTEM

Prepared for
Air Force Cambridge Research Lab

CONTRACT NO. F19628-69-C-0218
TM 71-200

Prepared by
EG&G International, Inc.
ENVIRONMENTAL EQUIPMENT DIVISION
151 Bear Hill Road
Waltham, Massachusetts 02154

NOVEMBER 1971

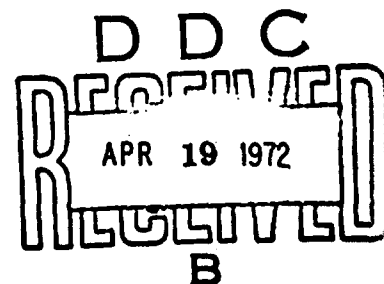

Unclassified

Security Classification

DOCUMENT CONTROL DATA - R&D

(Security classification of title, body of abstract and indexing annotation must be entered when the overall report is classified)

1. ORIGINATING ACTIVITY (Corporate author) EG&G International, Inc. Environmental Equipment Division 151 Bear Hill Road, Waltham, Massachusetts 02154		2a. REPORT SECURITY CLASSIFICATION Unclassified
		2b. GROUP
3. REPORT TITLE INSTRUCTION MANUAL EG&G MODEL 196 AIRCRAFT HYGROMETER SYSTEM		
4. DESCRIPTIVE NOTES (Type of report and inclusive dates) Scientific. Final. 12 February 1969 - 22 November 1971		
5. AUTHOR(S) (First name, middle initial, last name) Arthur Bisberg		
6. REPORT DATE November 1971	7a. TOTAL NO. OF PAGES 54	7b. NO. OF REFS 0
8a. CONTRACT OR GRANT NO. F19628-69-C-0218	9a. ORIGINATOR'S REPORT NUMBER(S)	
b. PROJECT, TASK, WORK UNIT NOS. 6020-02-01		
c. DOD ELEMENT 62101F	9b. OTHER REPORT NO(S) (Any other numbers that may be assigned this report)	
d. DOD SUBELEMENT 631000	AFCRL-72-0208	
10. DISTRIBUTION STATEMENT A- Approved for public release; distribution unlimited.		
11. SUPPLEMENTARY NOTES TECH, OTHER	12. SPONSORING MILITARY ACTIVITY Air Force Cambridge Research Laboratories (LY) L. G. Hanscom Field Bedford, Massachusetts 01730	

13. ABSTRACT

An aircraft optical dew-point hygrometer was designed and fabricated. The instrument incorporates a cryogenic heat pump to provide an extended range of mirror temperature depressional capability (50 to -100°C) with rapid response. The hygrometer will be installed aboard a C-130 aircraft for flight testing.

TABLE OF CONTENTS

	<u>Page</u>
GENERAL INFORMATION	1
General Description	1
Specifications	2
INSTALLATION	3
The Control Unit	3
The Sensor	3
OPERATING INSTRUCTIONS	5
Circuit Description	7
Sensor	7
Cables	8
MODEL 912-C CONTROL AMPLIFIER	9
General Description	9
Adjustments	10
Balance	10
Current Limit	10
Gain	11
Compensation	12
Thickness	12
Power Amplifier	18
Temperature Measurement Circuit	19
APPENDIX A - Instructions for Cryogenic Refrigerator	
APPENDIX B - List of Drawings	

LIST OF ILLUSTRATIONS

<u>Figure</u>		
Frontispiece	Model 196, Aircraft Hygrometer System	ii
i	Model 912-C Control Amplifier, Schematic Diagram	14
2	Model 912-C Control Amplifier Assy	15



EG&G Model 196 Aircraft Hygrometer System

GENERAL INFORMATION

General Description

The Model 196 Control Unit is designed for use in an Aircraft Hygrometer System when used with the Model 196 Hygrometer Sensor Head. The control unit contains the control circuitry and power supply for the sensor and provides an output voltage for recording temperature data as well as a meter for reading mirror temperature.

The Model 196 Sensor is designed for mounting within the aircraft. An air sample flow of 4 to 6 SCFH must be provided by external means through the 1/4 inch tube fitting. The components are outlined in the Interface Drawing D12897.

SPECIFICATIONS

Cooling Capability:	Cools to -100°C in steady state condition with 120 psig air supply. Heats to $+35^{\circ}\text{C}$ in Test mode.
Sample rate:	4 to 6 SCFH
Air Requirement:	Cooling air 3 SCFM (max) at 120 psig.
Dew Point Temperature Readout:	-100°C to $+50^{\circ}\text{C}$ on panel meter.
Voltage output:	-2.5V to $+2.5\text{V}$ dc recorder output linearly corresponding to -100°C to -50°C or -50°C to 0°C or 0°C to $+50^{\circ}\text{C}$ selected by switch.
Output Calibrate:	Low scale and high scale as selected by switch.
Mirror Temperature Repeatability:	$\pm 0.2^{\circ}\text{C}$
Mirror Viewing:	Microscope
Power:	115 VAC 60 to 400 Hz, 3 amp fuse.

INSTALLATION

The dimensions for the sensor and control unit are specified in Dwg B16423. The location selected for the control unit must be within 50 feet of the sensor installation, per Dwg C16282.

The Control Unit

The control unit is a 19" rack mounted panel which provides power and control functions for the hygrometer system. On the front panel are the SELECTOR switch which selects the output voltage range fed into the recorder output connector, the temperature meter which reads the mirror temperature over the range of -100 to $+50^{\circ}\text{C}$ whenever the instrument is turned on, the control condition meter, the ON/OFF switch, the fuse holder, and the ON/OFF indicator light. At the rear panel are two connectors J1 and J2 which are connected to the sensing head by means of cables W1 and W2. (See Dwg C16282.) Also, connector J3 provides recorder output signals and connector J4 is the power input connector. Input power to the system is applied only at the control unit rear panel and is 115 VAC, 60 to 400 Hz.

The requirements for the electrical installation are shown in Dwg C16282. Power is applied to the POWER IN receptacle located at the rear of the control unit. Connection to the sensor is shown in Dwgs B16428 and B16424. The data output for the readout device is obtained from the DEW POINT DATA OUT receptacle located at the rear of the control unit, Dwg B16427.

The Sensor

The 196 Sensor is an optically sensed dew point hygrometer utilizing a Sterling heat pump as a cooling source and a copper constantan thermocouple as a mirror temperature

sensor. The sensing head should be located near the sample stream. Connection to the sample stream is made by means of a short length of 1/4" stainless steel tubing to the sample inlet. The sample flow is returned to the sample system through the sample outlet by means of 1/4" tubing. A pressure tap is provided at the sensor by means of a 1/4" tube fitting such that pressure measurements can be made in the sample chamber during operation. Knowledge of the chamber pressure is useful for establishing the proper flow and applying corrections based on the pressure of the sample in the chamber. The sensor can be provided with a high pressure air supply for the operation of the Sterling heat pump. These connections are shown on Dwg D12897. Connections to the control unit are made by means of two connectors in the upper portion of the sensor. The upper and lower portion of the sensor are interconnected by means of a short cable. A microscope is provided in the upper portion of the sensor to allow the operator to observe the mirror surface during operation if desired. The sensor can be mounted through a hole in a horizontal surface by means of the flange provided. The upper portion of the sensor can be removed after removing the three hold down screws. Removal of the upper sensor is required for mirror surface cleaning. Several controls are provided in the upper portion of the sensor for operation of the instrument. These are the control condition meter, the balance knob and the control switch which provides the function of COOL, OPERATE, or TEST.

OPERATING INSTRUCTIONS

After initial installation wherein power is applied to the control unit, sample lines are connected to the sensing head and a source of air pressure is provided for the Sterling heat pump, the instrument may be placed into operation by opening the air supply to the Sterling heat pump and allowing 20 to 30 minutes for the heat pump to reach equilibrium temperature. This preliminary cool down should be accomplished with the power switch in the OFF position or with the control switch in the COOL position and the POWER switch on. If the CONTROL switch is in the COOL position with power On, the temperature meter will indicate mirror temperature and will show a gradual drop in temperature as the Sterling heat pump cools the mirror. The Sterling heat pump should come on immediately when pressure is applied, accompanied by a reciprocating motion of the piston. If the piston is hung up initially, remove the knurled screw at the bottom of the plastic dome under the sensor unit and manually move the piston until it runs with a reciprocating motion of its own accord, then replace the plastic dome. See Appendix for further instructions. The instrument can be put into operation in a shorter period of time if it is not desired to use the entire range of the instrument capability. Within 10 or 15 minutes the instrument will be cold enough to measure ambient dew point temperatures. After the mirror has cooled down, the mirror surface may be cleaned by removing the three hold down screws at the rim of the upper sensor and then lifting the upper portion of the sensor off. Frost will accumulate on the mirror surface and this may be dispelled by placing the control switch in the TEST position. This causes the mirror surface to be heated to approximately $+35^{\circ}\text{C}$, causing the ice to melt. At this point the gold plated mirror surface may be gently cleaned using a Q-tip. The upper portion of the sensor may now be replaced by first seeing that the O-ring is in place and then lining up the alignment pins in the upper sensor portion. With the CONTROL switch still in the TEST position adjust the balance knob for a reading on the control condition meter of between 0.3 and 0.7. If this adjustment is beyond the range of the balance knob

it is indicative of an unbalance in the optical system. If the mirror surface is clean and the light source is working, a course adjustment that will have the same effect as the balance knob can be made by using a small Allen wrench on the bias adjust screw at the light source mount. To achieve access to the light source, the upper housing that supports the control switch, the control condition meter, and the balance knob on the upper sensor must be removed. With the control condition meter balanced to mid-scale through the use of the balance knob, the instrument may now be placed into operation by placing the control switch in the OPERATE position. Normal operation of the instrument at this point is indicated by a rapid drop in the control condition meter indication, indicative of the fact that zero current is being fed to the heater and therefore the mirror surface will cool at the maximum rate.

Once the instrument has been on long enough to be able to cool to a temperature of -90°C and the balance of the control condition meter can be accomplished with the Test switch in the TEST position, then the instrument is ready for operation. The air flow rate should be about 4 to 6 SCFH. At low frost points higher flow rates are helpful in improving the speed of response of the instrument. At the higher frost points (-10°C) a high flow rate will tend to cause oscillations in the system output. A significant pressure change in the sample will result in a change in dew point. For this reason, a pressure tap is provided at the side of the sensor to make pressure measurements during set up of the sample flow system.

Proper hygrometer operation is checked by checking the balance of the control condition meter in the test mode and by then observing the dynamic operation when the control switch is returned to the OPERATE position. The proper dynamic operation is the following sequence.

1. Control condition balance in test mode, with mirror temperature near $+30^{\circ}\text{C}$.
2. When control switch is placed in OPERATE, the control condition meter drops to 0 reading (indicating zero heating) and the temperature drops at a maximum rate.

3. When temperature reaches frost point of sample, it overshoots. Then control condition meter rises.
4. The size and duration of the overshoot depends on the frost point temperature (large and long for low frost points). At high frost points the hygrometer will tend to oscillate as it settles down on a frost point reading. Excessive oscillation can be reduced by a reduction in flow rate.
5. When the system reaches the steady state the control condition meter will read a number indicative of the heater current required to maintain the mirror temperature near 0 for lowest frost points and near 1 for highest dew points. The meter will make rapid fluctuations about the mean reading for small variations in sample frost point.

Circuit Description

The schematic of the Model 196 Aircraft Hygrometer is shown in Dwg E16551. The sensor is shown at the left and is divided into the upper sensor and the lower sensor. The control unit is made up of four sections, the power supply, the control amplifier, the power amplifier and the temperature measurement circuit.

Sensor:

The lower sensor is electrically quite simple. While it contains the Sterling heat pump which is totally mechanical and pneumatic in operation, electrically it only contains the resistive heater on the mirror assembly and the copper constantan thermocouple imbedded in the mirror surface. The thermocouple leads are brought through all connections with thermocouple connectors to eliminate errors in the measuring circuit. All lower sensor leads are brought to the upper sensor prior to connection to the control unit. For test purposes the resistance of the heater is $4.2\Omega \pm 20\%$ and the thermocouple is less than 10Ω as measured on a Simpson meter.

The upper sensor houses the light source, photo cells, balance control, control switch, and thermocouple reference junction.

The thermocouple reference junction is a self contained potted unit with internal battery which has a life of 2000 hours and a shelf life of 2 years. The battery is off when the power is off or when the cable is disconnected. The thermocouple reference provides an output from the measuring thermocouple which is referenced to 0°C and eliminates the necessity of using thermocouple wires in the cabling from the sensor to the control unit.

The lamp is the light source for the optical frost detector and is potted into the screw in lamp assembly together with the bias photo cell. The lamp is connected in series with a 47 Ω , 1W resistor to the +10V regulated power supply. The light to the bias photo cell in the lamp assembly is controlled by means of an Allen screw shutter adjustment which is set during alignment to result in center scale reading of the control condition meter when the balance pot is centered and the control switch is in the Test mode with the mirror clean and dry.

The direct photo cell which looks directly at light reflected from the mirror surface is potted into a mount and screwed into the upper sensor housing. There is no adjustment associated with the direct cell but the lens surface should be maintained in a clean condition which is also true of the lens on the lamp assembly.

The bias pot is a multi-turn pot electrically connected to the photo cell bridge circuit and is used for fine adjustment of the bridge balance.

The control switch is a three-position switch used to provide normal operating mode, test mode and full cooling mode of operation of the system.

Cables:

The cables are shown in the schematic drawings and referenced to individual cable Dwg B16424 and B16426. Note that some of the leads are shielded and if the cables are run near sources of high amplitude high frequency sources, an overall cable shield would be desirable.

Model 912-C Control Amplifier

General Description

The Model 912-C Control Amplifier is a general purpose, high gain, stable dc amplifier used extensively in Cambridge Systems dew point hygrometer. This unit serves as the main feedback amplifier in the dew point mirror servo loop, amplifying the output of the dc-excited photoresistor bridge to a sufficient level to drive an emitter follower chain. The emitter followers control the direct current furnished to the sensor.

The 912-C printed circuit card contains a portion of the photoresistor bridge, including a balance pot which is adjusted to trim the range of operation of the main BALANCE control of the hygrometer in which the 912-C is installed; an adjustable offset resistance control labeled THICKNESS utilized in the hygrometer operate mode as a reference against which the photoresistor resistance (which varies as a function of the dew layer thickness) is automatically compared, thereby establishing the dew layer thickness on which the hygrometer will operate. The output of the photoresistor bridge is amplified by a solid state amplifier module (A1) which drives an emitter follower circuit. A rate compensated feedback loop is used around the amplifier-emitter follower chain to electrically compensate for the thermal lag characteristic of the cooling device in the instrument sensing head. The first emitter follower stage provides output current to operate a 0-1 ma meter indicating the CONTROL CONDITION (or amplifier output signal) of the 912-C amplifier. An adjustable current limit resistor, located in the first emitter follower stage, controls the maximum current which can be furnished to the mirror heater when the card is installed in a hygrometer. The last emitter follower in the chain contains an adjustable gain control which sets the magnitude of the change in the direct current output for a given increment in photoresistor bridge change (dew layer thickness). Power for the photoresistor bridge and all amplifier circuits is derived from the zener referenced transistor-regulated supply on the unit. The card operates directly from 115 VAC.

Adjustments

Balance

The 912-C BALANCE control performs the same function as the BALANCE control on the hygrometer, providing additional adjustment range over the hygrometer control. The 912-C BALANCE control may be adjusted as follows:

NOTE

This adjustment procedure assumes proper adjustment of the dew point sensor optics.

- (a) With 912-C card plugged into its card holder, and CONTROL switch in TEST position, first set the BALANCE control on the hygrometer control panel to its center position against the stop.
- (b) Then, observing the CONTROL CONDITION meter, adjust the BALANCE control on the 912-C card to set the CONTROL CONDITION center scale.

Current Limit

- (a) The CURRENT LIMIT adjustment is made for the purpose of setting the maximum current through the mirror heater when the control circuit is full on demanding maximum current. The adjustment is always made with the 912-C card installed in a hygrometer, with the amplifier in its full on operating state, and while the voltage to the mirror heater is monitored in accordance with the hygrometer unit instructions elsewhere in this manual.

- (b) Adjust the CURRENT LIMIT starting from a fully counterclockwise position to obtain the desired voltage on the sensor heater terminals of 8V.

Gain

The GAIN control functions to adjust the overall gain of the optical-system mirror-temperature control loop in the hygrometer. The GAIN control has numbers embossed on the face of the pot which serve as index marks only and do not indicate the actual gain in the control loop. The setting of this control should be made with the following physical mechanisms in mind:

The overall gain of the control loop is dependent on both the electronic gain in the amplifier and the gain of the condensation phenomena. The gain of the condensation phenomena is related to the mobility of the condensate, which is both a function of absolute temperature and the state of the condensate (water or ice), being high for high temperatures and water deposits and low for low temperatures and ice deposits. The electronic gain control may be used to compensate for this change in gain of the condensate phenomena.

When the 912-C card leaves the factory, the GAIN control will have been adjusted for optimum performance over the intended range of application, if that range has been stated by the customer, or to a compromise setting that will insure proper operation over the entire instrument range. A setting of approximately 6.5 is normal for operation over the entire instrument range. Higher settings of 8 or 9 will result in improved dynamic performance when the instrument is measuring dew points of -60°F or lower. Settings lower than 6.5 may be used when measuring dew points of 100°F or higher and will reduce the tendency toward instrument oscillation at these dew points.

In this case, the proper setting will be found to be somewhat less than that which causes instrument oscillation, as indicated by the CONTROL CONDITION meter alternately going from full upscale deflection to full downscale deflection. For best performance under these conditions, the GAIN must be adjusted in combination with the COMPENSATION control, below.

Compensation

The COMPENSATION control serves to introduce phase lead into the electronic amplifier to compensate for the thermal phase lag characteristic of the thermoelectric cooling device used in the dew point sensing head. Introduction of this phase lead into the optical-system-mirror-temperature control loop permits the loop to be operated at a higher gain setting without oscillation resulting in improved dynamic performance. The frequency response of this compensation network is such that it is effective only at dew points of 20°C and above. The setting of the control is unimportant if measuring dew points below 20°C.

The proper adjustment of the COMPENSATION control is achieved by introducing a gas sample into the hygrometer at the highest dew point anticipated. With the instrument operating normally on this dew point rotate the COMPENSATION control full counterclockwise (25 turn pot with no stop, pot clicks once per rotation when end of resistance range is reached) point and advance the GAIN control until a steady oscillation is obtained. Next, rotate the COMPENSATION control clockwise in increments of 5 turns allowing a few minutes between each increment, until the oscillation stops. Rebalance the instrument.

Thickness

The THICKNESS control functions to set the thickness of the condensate layer required on the hygrometer mirror before the optical-system-mirror-temperature control

loop begins to maintain the preset thickness by detecting small changes in the thickness and adjusting the mirror temperature in a direction that tends to hold the layer thickness constant. The THICKNESS control has numbers embossed on the face of the pot which serve as index marks only and do not indicate the actual thickness of the condensate layer. The setting of the THICKNESS control has no effect on the accuracy of the instrument. Any setting represents a compromise between fast dynamic response and insensitivity to contaminants, making the setting primarily dependent on the characteristic most desired in the application of the hygrometer. The best setting can only be found through experimentation in the actual application. The unit is shipped from the factory with a setting of approximately 1.5. This setting provides fast response and has been found satisfactory for clean samples such as room air, bottled gas, etc. For operation on samples of higher contamination levels the THICKNESS control may be advanced to higher settings resulting in longer operational intervals between mirror cleaning, but with the most apparent sacrifice in the time required to establish the initial operating layer thickness and some sacrifice in the response of the instrument to changes in dew point.

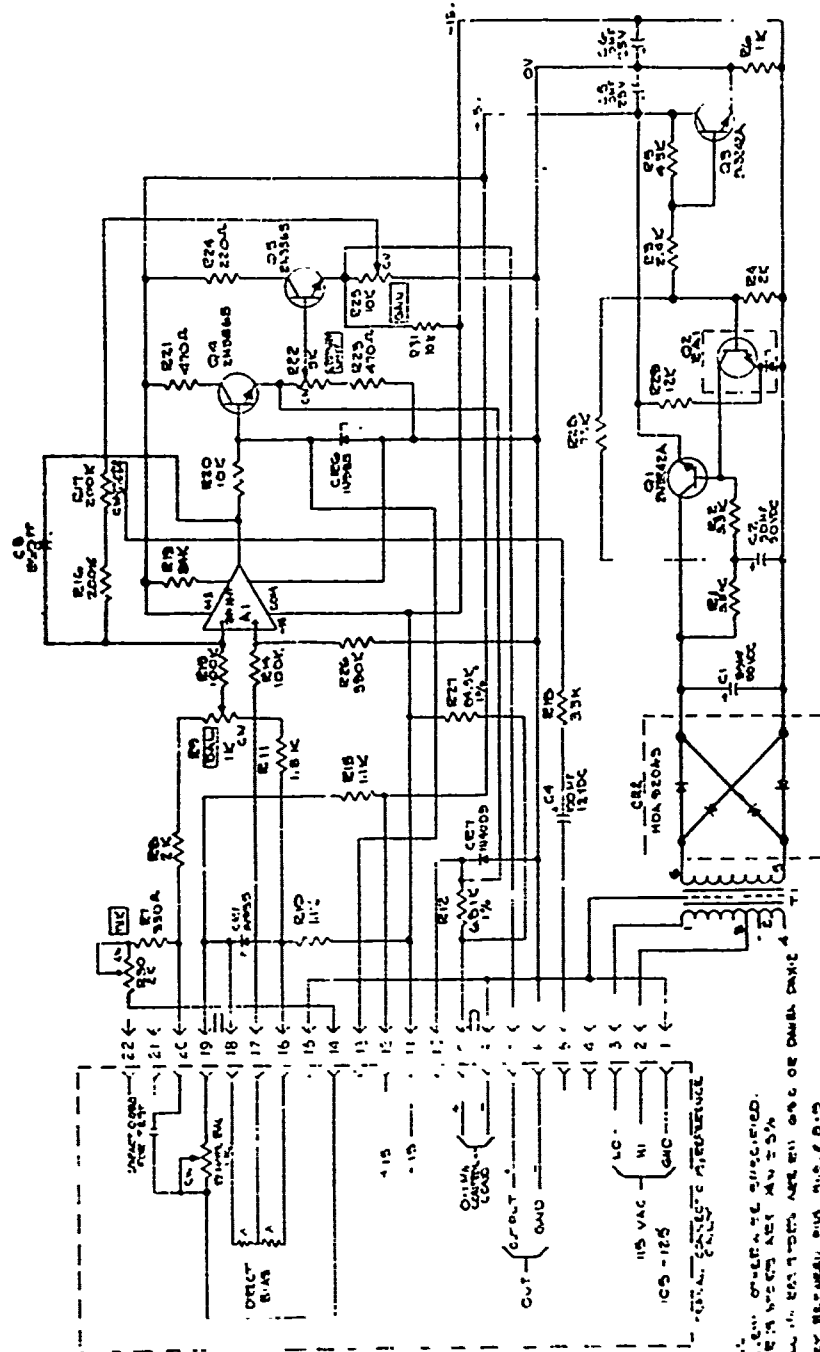
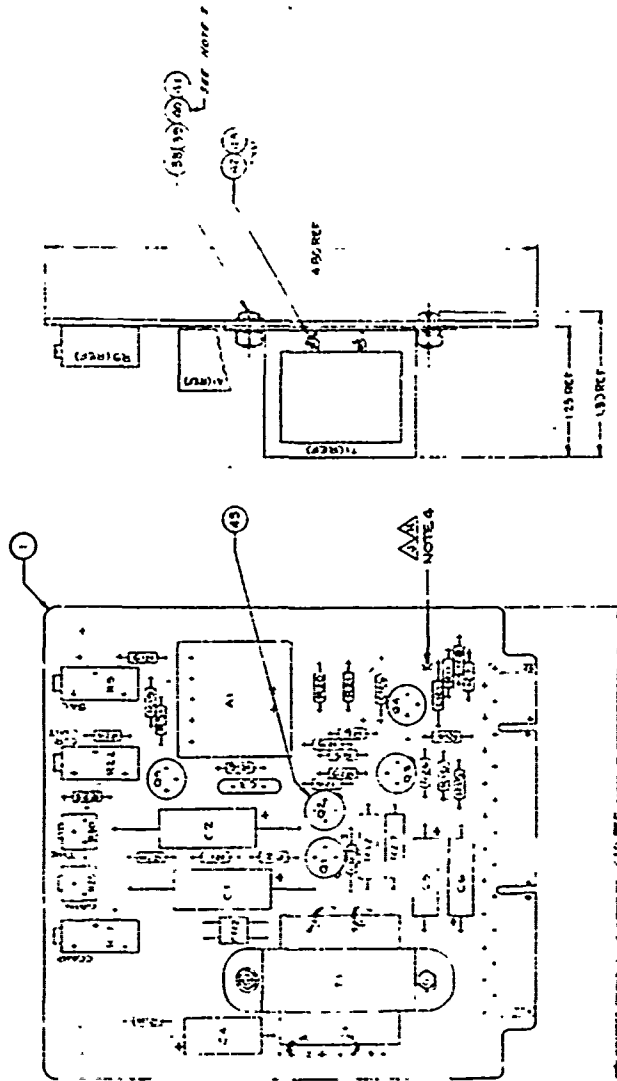

Figure 1. Model 912-C Control Amplifier, Schematic Diagram.

- 1. ALL OPERATOR ADJUSTMENTS.
- 2. ALL THE RESISTORS ARE 1% OR 5% TOLERANCE.
- 3. FOR BEHAVIOR, SEE 912-C Datasheet.
- 4. MAKE POT. CURRENT LIMIT POT. AND CURRENT LIMIT POT. TO MAKE THE THE TRIM. POT. AND GAIN POT. ARE 100-0-100.



- 1. AL-1014-R PER MIL-STD-175
- FOR PARTS NOT RETICULED BY
- PAR. 1.1, SEE PARTS DESCRIPTION
- 2. 110V AC, 60 Hz, MILITARY TYPE
- 3. 250 MA, 100 V, MILITARY TYPE
- 4. COMMERCIAL EQUIVALENT
- 5. 100 MA, 100 V, MILITARY TYPE
- 6. 100 MA, 100 V, MILITARY TYPE
- 7. 100 MA, 100 V, MILITARY TYPE
- 8. 100 MA, 100 V, MILITARY TYPE
- 9. 100 MA, 100 V, MILITARY TYPE
- 10. 100 MA, 100 V, MILITARY TYPE
- 11. 100 MA, 100 V, MILITARY TYPE
- 12. 100 MA, 100 V, MILITARY TYPE
- 13. 100 MA, 100 V, MILITARY TYPE
- 14. 100 MA, 100 V, MILITARY TYPE
- 15. 100 MA, 100 V, MILITARY TYPE
- 16. 100 MA, 100 V, MILITARY TYPE
- 17. 100 MA, 100 V, MILITARY TYPE
- 18. 100 MA, 100 V, MILITARY TYPE
- 19. 100 MA, 100 V, MILITARY TYPE
- 20. 100 MA, 100 V, MILITARY TYPE
- 21. 100 MA, 100 V, MILITARY TYPE
- 22. 100 MA, 100 V, MILITARY TYPE
- 23. 100 MA, 100 V, MILITARY TYPE
- 24. 100 MA, 100 V, MILITARY TYPE
- 25. 100 MA, 100 V, MILITARY TYPE
- 26. 100 MA, 100 V, MILITARY TYPE
- 27. 100 MA, 100 V, MILITARY TYPE
- 28. 100 MA, 100 V, MILITARY TYPE
- 29. 100 MA, 100 V, MILITARY TYPE
- 30. 100 MA, 100 V, MILITARY TYPE
- 31. 100 MA, 100 V, MILITARY TYPE
- 32. 100 MA, 100 V, MILITARY TYPE
- 33. 100 MA, 100 V, MILITARY TYPE
- 34. 100 MA, 100 V, MILITARY TYPE
- 35. 100 MA, 100 V, MILITARY TYPE
- 36. 100 MA, 100 V, MILITARY TYPE
- 37. 100 MA, 100 V, MILITARY TYPE
- 38. 100 MA, 100 V, MILITARY TYPE
- 39. 100 MA, 100 V, MILITARY TYPE
- 40. 100 MA, 100 V, MILITARY TYPE
- 41. 100 MA, 100 V, MILITARY TYPE
- 42. 100 MA, 100 V, MILITARY TYPE
- 43. 100 MA, 100 V, MILITARY TYPE
- 44. 100 MA, 100 V, MILITARY TYPE
- 45. 100 MA, 100 V, MILITARY TYPE

SEE NOTE 1 FOR
 PARTS 200 AND 41
 PARTS 200 AND 41

Figure 2. Model 912-C Control Amplifier Assembly (Sheet 1 of 3).

Reproduced from
best available copy.

ITEM NO	REF NO	PART OR IDENT NO	QTY	DESCRIPTION		
1		D-11981	1	PRINTED WIRING BD (MASTER DWG)		
2	R1	RC07GF332J	3	RES. COMP, 3.3K, 1/4W, MIL-R-11	NOTE 1 OF L/M TYP.	
3	R20 R21	RC07GF103J	2	RES. COMP, 10K, 1/4W, MIL-R-11		
4	R3	RC07GF242J	1	RES. COMP, 2.4K, 1/4W, MIL-R-11		
5	R4 R8	RC07GF202J	2	RES. COMP, 2K, 1/4W, MIL-R-11		
6	R5	RC07GF432J	1	RES. COMP, 4.3K, 1/4W, MIL-R-11		
7	R6	RC07GF102J	1	RES. COMP, 1.0K, 1/4W, MIL-R-11		
8	R7	RC07GF331J	1	RES. COMP, 330 Ω , 1/4W, MIL-R-11		
9	R11	RC07GF152J	1	RES. COMP, 1.5K, 1/4W, MIL-R-11		
10	R9	77PRIK	1	RES. VAR, 1K, HELITRIM (BECKMAN)		
11	R10 R15	RC07GF112J	2	RES. COMP, 1.1K, 1/4W, MIL-R-11		
12	R12	RN65D6811F	1	RES. FIXED, 6.81K, MIL-R-10509		
13	R13 R14	RC07GF104J	2	RES. COMP, 100K, 1/4W, MIL-R-11		
14	R16	RC07GF204J	1	RES. COMP, 200K, 1/4W, MIL-R-11		
15	R17	77PR200K	1	RES. VAR, 200K, HELITRIM (BECKMAN)		
16	R19	RC07GF243J	1	RES. COMP, 24K, 1/4W, MIL-R-11		
17	R21 R23	RC07GF471J	2	RES. COMP, 470 Ω , 1/4W, MIL-R-11		
18	R22	77PR5K	1	RES. VAR, 5K, HELITRIM (BECKMAN)		
19	R24	RC07GF221J	1	RES. COMP, 220 Ω , 1/4W, MIL-R-11		
20	R25	TYPE 310	1	RES. VAR, 10K (IRC)		
21	R26	RC07GF394J	1	RES. COMP, 390K, 1/4W, MIL-R-11		
22	R27	RN65D8452F	1	RES. FIXED, 84.5K, MIL-R-10509		
23	R28	RC07GF753J	1	RES. COMP, 75K, 1/4W, MIL-R-11		
24	R29	RC07GF123J	1	RES. COMP, 12K, 1/4W, MIL-R-11		
25	R30	TYPE 310	1	RES. VAR, 2K (IRC)		
				LM	CODE IDENT NO. 22905 11942	REV. K
				SCALE NONE	SHEET 2 OF 3	

Figure 2. Model 912-C Control Amplifier Assembly (Sheet 2 of 3).

ITEM NO	REF NO	PART OR IDENT NO	QTY	DESCRIPTION	REV.
26	C1 C2	TE1307	2	CAPACITOR, 50uf, 50VDC (SPRAGUE)	
27	C3	CD19F561J	1	CAPACITOR, 560pf (CDE)	
28	C4	TE1133	1	CAPACITOR, 100uf, 12VDC (SPRAGUE)	
29	C5 C6	TE1204	2	CAPACITOR, 10uf, 25VDC (SPRAGUE)	
30	CR1 CR6	1N935	2	SEMI CONDUCTOR DEVICE - DIODE	
31	CR2	MDR-22DA-3	1	RECTIFIER (MOTOROLA)	
32	CR7	1N4009	1	SEMICONDUCTOR DEVICE - DIODE	
△	A1	SQ10A	1	AMPLIFIER (NEXUS)	
34	Q1 Q3	2N3242A	2	TRANSISTOR (RCA)	
35	Q2	RA1	1	TRANSISTOR (GE)	
36	Q4 Q5	2N3565	2	TRANSISTOR (FAIRCHILD)	
37	T1	A10807	1	TRANSFORMER	
→		.112-40	2	SCREW x .31LG PN HD	
		#4	2	WASHER, FLAT SST	
△		#4	2	WASHER, LOCK, INTERNAL TEETH - CRES -	
		.112-40	2	NUT, HEX	
		#18	AR	WIRE, BUSS	
		#18	AR	SLEEVING, TEFLON, CLEAR	
		D11940	REF	SCHEMATIC	
		7717-5N	1	PAD, TSTR, WHITE (LAFAYETTE)	
		A11515	REF	PROCEDURE, CHECKOUT	
				NOTE	
				1. MILITARY TYPE DESIGNATIONS MAY BE SUPPLIED AS COMMERCIAL EQUIVALENT.	
				LM	
				CODE IDENT. NO.	
				22905	
				11942	
				REV.	
				K	
				SCALE NONE	
				SHEET 3 OF 3	

Figure 2. Model 912-C Control Amplifier Assembly (Sheet 3 of 3).

Power Amplifier

The power amplifier drives the 4.2 μ sensor mirror heater using a 2N3055 silicon power transistor to control heater current from the regulated +10V power supply. In addition to amplifying the signal from the 912 control amplifier, the power amplifier has a variable gain feature to improve the dynamic response of the instrument over a wide range of measured frost points. At low frost points where the mass transfer of water vapor to the mirror surface is low, a high gain is required for rapid response while at high frost points the inverse is true. This variable gain is accomplished by means of a variable resistor (a lamp coupled photocell) in the feedback loop of the input amplifier A2. The 912 control amplifier feeds A2 at R14. The gain of A2 is determined by the resistance of R15 in series with the coupled photocell HP-5082-4522 and the factory setting of the Dew Gain pot R6. The variation in gain of A2 is controlled by the voltage fed to the lamp of the coupled photocell which in turn is derived from the temperature measurement circuit. A voltage proportional to mirror temperature, 0V at -100°C and +10V at +50°C is fed to R10 of A3 and then drives Q3 to control the lamp and therefore the resistance of the HP-5082-4522. The output of A2 which is the control signal from the 912 amplifier with variable gain is taken from R5 and fed through the control switch at the upper sensor and then returned to the summing junction of A1 together with the voltage from the temperature measuring circuit. The injection of a current proportional to mirror temperature at the summing junction of A1 makes the mirror control circuit a temperature servo. In hygrometers not utilizing this feature, a step change in frost thickness would result in a step change in mirror current but due to the mirror thermal lag the mirror temperature changes exponentially with a time constant. With the temperature servo feature, a step change in frost thickness tends to force a step change in mirror temperature resulting in a reduction of the mirror thermal

response lag equal to the loop gain or about a factor of 10. The output of A1 then feeds emitter followers Q1 and Q2 to drive the mirror heater.

Temperature Measurement Circuit

The temperature measurement circuit accepts a low level signal from the mirror thermocouple via the reference junction and amplifies it to a 10 volt level and linearizes it to provide signals for the panel temperature meter and the servo feedback required in the power amplifier. Additionally, a switching network and signal conditioning is available to provide switched output signals of $-2.5V$ to $+2.5V$ in three temperature ranges of $-100^{\circ}C$ to $-50^{\circ}C$, $-50^{\circ}C$ to $0^{\circ}C$, and $0^{\circ}C$ to $+50^{\circ}C$. The input signal is the referenced thermocouple signal of approximately $40 \mu v$ per degree C and is amplified by the chopper stabilized amplifier A2. The voltage output of the copper constantan thermocouple is not linear with temperature but is slightly concave downward. Linearization is accomplished in the amplifier A2 by the use of biased switching transistors in the feedback network. The adjustment of the network pots R6 through R12 and R28, R29 is described in drawing D16289. Please note that in this detailed drawing the reference designation numbers of the pots are not the same as those in the overall schematic. The adjustment has been performed at the factory and should not be repeated often in the field. Input voltage to simulate temperature can be obtained with a thermocouple potentiometer or from a low variable source and a list of thermocouple voltage vs temperature. With reference to the overall schematic, the temperature meter is calibrated at $+50^{\circ}C$ input with R33 while the $-2.5V$ to $+2.5V$ output is adjusted as follows:

Measure the output at pin A of J3 to ground and with the output selector switch at $-100^{\circ}C$ to $-50^{\circ}C$ and input corresponding to $-100^{\circ}C$ set R63 for $-2.5V$ out. Then with input simulating $-50^{\circ}C$ set R43 for $+2.5V$ out. With switch in $-50^{\circ}C$ to $0^{\circ}C$ position and with $-50^{\circ}C$ simulated set R38 for output of $-2.5V$. With switch in $0^{\circ}C$ to $+50^{\circ}C$ position set R40 for $-2.5V$ out. The next two switch positions set the output to the ends of the range $-2.5V$ and $+2.5V$ regardless of hygrometer temperature reading.

These can be used in the aircraft to aid in setting up the recorder zero or to aid in setting the output select adjustment R48 for desired recorder sensitivity.

APPENDIX A

Instructions for Cryogenic Refrigerator

CONTENTS

	Page
Diagram of Cryogenic Refrigerator Air Supply System.	1
Air Supply	2
Installation On Leak Detectors	3
Starting.	4
Cool-Down Period	4
Stopping	4
Suggestions For Designing Custom Cold Trap Extensions	4
Maintenance	5
Repair Instructions:-	
Section 1. When Refrigerator Stops	6
Section 2. Removal and Cleaning Of Mechanism 3150G	6
Section 3. Inspection and Cleaning of Cylinder	7
Section 4. Removal and Inspection of Valves	7
Section 5. Drive Piston Removal and Cleaning	7
Section 6. Rod Seal Inspection and Replacement.	8
Performance Plot	9
Exploded View	10
Parts List	11
Dimensional Drawings	
3150G	12, 13
3150	14, 15
3150A	16, 17
3150B	18, 19
Composite	20, 21

CRYOGENIC REFRIGERATOR AIR SUPPLY SYSTEM

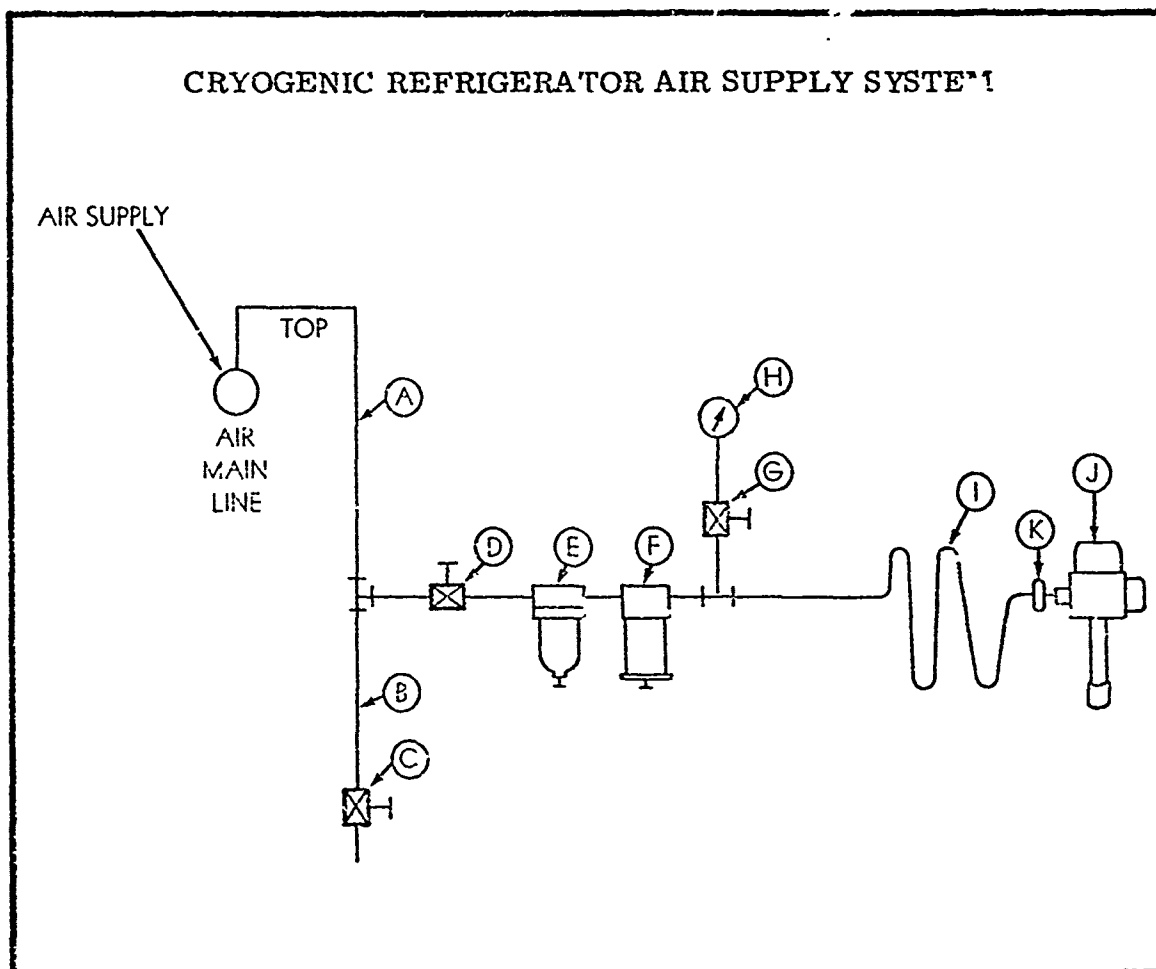

- A. Supply pipe - 1/2" recommended - take from top of main line
- B. Drip leg 1/2"
- C. Drip leg blowdown valve 1/2"
- D. Shutoff valve - 1/2"
- E. Coarse filter and water trap 1/2"
- F. Oil fog fine filter 3/4" in, bushed 1/4" out (furnished)
- G. Gauge snubber valve
- H. 0-150 psi pressure gauge
- I. 1/4" air hose, 12' long, 1/4" male pipe connection one end, SAE female flare fitting other end to fit K (furnished)
- J. Cryogenic Refrigerator
- K. Excess liquid water warning indicator with fittings to connect to I and J (furnished)

AIR SUPPLY

Air supply pressures from 65 psi to 125 psi may be used with the Series 3150 Refrigerator. The higher the air supply pressure, the lower the limiting temperature, and the shorter the cool-down period. A supply pressure of 85 psi, which is available in most laboratories, gives a no load limiting temperature of about -140°C (-220°F). This is satisfactory for small loads such as leak detector traps.

Air consumption is about 2.1 standard cubic feet per minute (85 psi) at the start of the cool-down period. Consumption decreases to about 1 cubic foot per minute as the Refrigerator reaches its limiting temperature.

We suggest an after-cooler or long runs of pipe to permit the air to cool down to room temperature before it gets to the Refrigerator's filter system. The cooled air should be passed through a discharge water separating trap (E), or through a tank, to collect the water that normally condenses after air is compressed. This trap (E) should be as cool as, or cooler than, any other part of the branch air line system so that all water condensate will collect here. This is especially necessary in the summer months when humidity is high. The liquid water warning indicator (K) shows if these conditions have not been fulfilled. Corrective action must then be taken.

Variations in air pressure due to typical on-off compressor pressure control do not cause the temperature to rise or fall significantly.

If a separate compressor is used to operate the Cryogenic Refrigerator, the compressor rating must be at least 2.5 standard cubic feet per minute while operating at 85 psi discharge pressure. The compressor should be equipped with controls for constant running.

If a separate compressor is used that has no excess capacity, it must be designed for continuous duty. Many compressors are designed only for light duty cycles. Only pressure oiled compressors are recommended.

If the air compressor is worn, abnormally large amounts of oil may be introduced and two oil fog filters (F) may be required instead of the single one shown.

If uninterrupted operation is desired for as long as possible, an automatic, regenerating, heatless desiccant air dryer, as made by the Gilbert and Barker Company or the Kahn Company, is desirable. Using such dryers, The Welch Scientific Company has obtained uninterrupted operating periods of as long as six months. The filter (K) should precede the dryer to keep oil from the desiccant. Another filter (K) should follow to keep desiccant dust from the Cryogenic Refrigerator. A wick type lubricator should follow this second filter. (Instructions for making this modification are presented later in this text.)

Mechanical refrigerator air dryers are the next best in performance. They are less expensive than desiccant dryers where more than one Refrigerator is used.

Simple, non-regenerating chemical or deliquescent dryers are about as effective as mechanical refrigerator dryers but will probably have a higher operating cost.

The snubber valve (G) protects the gauge (H) from being worn out by the fluctuating pressure caused by operation.

The gauge (H) acts as a safety device by indicating if the filter (F) is clogged and shows whether air pressure is in the correct range for optimum operation.

If the leak detector or system employing the Refrigerator is frequently moved from place to place, it may be convenient to mount the oil filter (F) on the leak detector and use a short hose. A longer hose can be run over to the wall at (D). Quick, plug-in air hose disconnectors with built-in valves are especially convenient for this purpose. These fittings are available from industrial hardware dealers.

The oil fog filter (F) may eventually clog with dirt, but oil is continuously trapped without causing clogging. Oil must be drained from the filter occasionally.

The Refrigerator's regenerator effectively rejects gaseous oil in the air supply. However, liquid oil, normally present as fog in the compressor discharge, can pass through the regenerator in sufficient quantity to eventually jam the displacer. A very fine filter, such as that furnished, can remove most of this fog. It is however, not desirable to remove all of the oil. The Refrigerator requires a minute amount of oil normally met by the residual oil passing through the recommended oil mist filter. If extremely oil free air is used, such as that which comes from "oil-less" compressors, special means must be employed to maintain adequate lubrication. These means may sometimes be necessary with oil lubricated compressor systems also, if routine maintenance indicates inadequate oil. The liquid water warning indicator may be converted into a wick type lubricator as follows: Interchange connections so that inlet and outlet are reversed. Make a wick of #60 cotton thread stiffened by a thin tag wire which can feed oil from the bottom of the small green bowl up into the short brass tube connecting to the refrigerator. Use air compressor oil or SAE 20 weight, medium grade oil. Oil fed by this means is about 1/10CC per month.

INSTALLATION ON LEAK DETECTORS

To install the Refrigerator, remove the liquid nitrogen "bucket" from the leak detector cold trap. Six captive screws, reached by removing the transparent dome and the plastic foam air silencer, hold the Refrigerator in place. Follow the installation requirements for the various leak detectors listed below.

Veeco Leak Detector: The Model 3150 Refrigerator fits without any adapters.

CEC Leak Detector: The Model 3150A Refrigerator uses a flange adapter. Note: The leak detector cover must be cut away at one edge to close with the Refrigerator in place. Do not completely tighten the screws holding the Refrigerator. Atmospheric pressure will compress the "O" ring sufficiently to cause a leak tight seal. This will eliminate any metallic sound path between the Refrigerator and the leak detector flange.

NRC Leak Detector: The Model 3150B Refrigerator uses a flange adapter and "O" ring (3-3/8 x 3-5/8 x 1/8). The trap cover must be

removed.

General Electric Leak Detector: The Model 3150B Refrigerator uses a flange adapter and "O" ring (3-3/8 x 3-5/8 x 1/8). The table cover must be removed or trimmed to clear the Refrigerator.

After placement in the cold trap, tighten the captive screws and reinstall the plastic form air silencers. After connecting the air supply, the Refrigerator may be started.

STARTING

Turn on full air pressure. If the plunger is in the down position, the Refrigerator will start itself. Otherwise, depress the plunger with your finger.

The Refrigerator can be started automatically if an electric air valve and clock timer switch are installed in the air line. The plunger should be pushed down in preparation for automatic starting. Full air pressure is necessary immediately, not a gradual rise.

COOL-DOWN PERIOD

Once the Refrigerator is started, it needs no further attention, but be sure that the trap is evacuated. The Refrigerator will not reach its limiting temperature unless there is vacuum insulation in the trap.

The cold indicator, divided in 10 arbitrary units, registers the progress of the cool-down period. With an 85 psi air supply pressure, the Refrigerator reaches its limiting temperature in about 45 minutes. You may find that your particular leak detector is sufficiently cooled in 30 minutes for sensitive operation. The cold indicator meter will register between 8 and 8-1/2 at limit temperatures. (At 85 psi this corresponds to a temperature between -130°C and -150°C). The Refrigerator normally slows down to about 100 strokes per minute as it reaches limiting temperature.

If actual temperature measurements of the top of the cold end sleeve are desired, remove the two iron-constantan thermocouple leads from the meter and connect them to the usual thermocouple-potentiometer type of instrument normally employed for such measurements. The lower end of the copper sleeve, where the extended surfaces connect, can be as much as 40° colder than the upper end of the sleeve, where the supplied thermocouple is installed.

STOPPING

To stop the Cryogenic Refrigerator, turn off the air supply.

SUGGESTIONS FOR DESIGNING CUSTOM COLD TRAP EXTENSIONS

Make the cold area which "sees" the warm trap walls no larger than necessary consistent with good trap design. If the extension replaces a liquid nitrogen "reservoir" it is not always necessary to have the extension surfaces as large as the completely filled reservoir. If operation of the trap was satisfactory when the reservoir was half full, then operation with an extension equivalent to a half full

trap would likewise probably be satisfactory. "Cut and try" methods can be helpful in reaching the best compromise between the size of the extended area and the lowest possible temperature.

Polish the extension surfaces and the facing of the trap. This reduces radiant heat transfer.

The demountable joint between the cold extension and the cold end of the Refrigerator, (copper sleeve) should incorporate a soft crushed lead washer between the mating faces. The area of contact between the cold extension and the Refrigerator must be as large as possible to maximize thermal conductance across the joint. Use the tapped hole and shoulder provided to apply crush force. Refer to The Model 3150 drawing for an example. Avoid more than one demountable joint in the heat flow path.

All joints across which heat flows should be full cross section fusion joints. Welding, brazing, and soldering are advised. It is difficult to make an aluminum solder joint that will not deteriorate. Copper is recommended as the special extension material. Copper is easy to connect with silver solder or lead-tin solder joints.

Make the heat flow path cross-section generous. Do not introduce "bottlenecks" where the heat flow path is obviously constricted. However, the heavier gauge the extended surface is, the longer it will take to be cooled down by the Refrigerator. Fortunately, weight alone is not a limiting factor in determining the lowest temperatures attainable. In most cases it will be better to err in making the extensions "on the heavy side".

Keep the partial pressure of non condensible gases, such as air, below 1 millitorr. The refrigerator extension surfaces will reduce the partial pressure of water and oil to negligible levels as far as thermal conductivity is concerned. However, the pump system must remove the non condensible gases to below millitorr levels in order to maintain the vacuum insulation of the cold surface extensions.

Heavy deposits of condensate greatly increase the radiant heat load. A limitation of cooled surface area, or frequent cleaning may be necessary. On diffusion pumps 4" and larger, an air cooled baffle is recommended between the pump and refrigerated baffle to intercept heavy backstreaming and splashing.

MAINTENANCE

Under typical 24-hour work day operation, 6 days a week, turn the Refrigerator off once a week and let it warm up and stay warm one day. Oil and water inside the Refrigerator will usually drain to a place where they will not stop the Refrigerator should they re-freeze.

Under seven-day-a-week continuous operation, once a week pull out the mechanism, (marked 3150G on the exploded view). This can be done without warming. Briskly wipe the displacer 34 with a cloth so that frozen oil, water, and carbon dioxide are melted and removed. Quickly replace before frost deposit from the air gets too thick.

If a mechanically refrigerated dryer, and especially if a dessicant type dryer is used, the time between defrosting by either method above can be extended to many weeks or several months. Some experimentation to determine the time is required.

Inspect the drive piston 33 once a month at first. See Repair Section for disassembly instructions. Wipe off any sticky black sludge deposits. On older models, replace teflon rings (Nos. 11, 12, 13 on exploded view) with 5/8" O.D. x 1/2" I.D. buna N rings (Welch Pc. No. 41-4343). These replacement rings form little or no sludge. Drive piston rings should be oily. If they are not, increase oil content of the compressed air. With rubber O-Rings on the drive piston and correct oil this inspection period may be safely extended to six-month periods.

To insure proper thermal contact between the thermocouple lead and the copper sleeve, apply a bead of vacuum grease at that junction.

3150 REFRIGERATOR REPAIR INSTRUCTIONS:

Refer to Exploded View & Parts List in connection with these instructions.

Section 1) When the Refrigerator Keeps Stopping.

- A) If there is any water in the liquid water indicator, there is an excessive amount of condensation in the air supply lines. Such a condition must be remedied before there is any hope of the Refrigerator operating properly.
- B) If there is no water in the water indicator, allow the Refrigerator to defrost overnight, then restart the next morning.
- C) Should the Refrigerator continue to stop after defrosting has been tried, inspect sub-assembly 3150G (see section 2 below), and the inside of displacer cylinder (21) (see section 3 below), for excessive water and oil. This is recommended as preventive maintenance; the mechanism should be examined more or less frequently as indicated by experience for each application.

Section 2) Removal & Cleaning of Operating Mechanism 3150G.

(Can be done while cold)

- A) Remove cover 17.
- B) Remove muffler pads 6.
- C) Disconnect air line at 24.
- D) Remove 5 screws 51.
- E) Pull out 3150G - it is not necessary to disassemble further to clean.
 1. Wipe fiber displacer 34 with cloth to remove frozen water and oil, if any. Just before reinstalling rewipe if more frost has condensed on displacer.
 2. If displacer O-Rings 1 are choked with black sludge, wipe clean.
 3. If felt lubricator ring 9 is glazed with hard sludge, turn ring inside out for fresh grease surface, or replace, or wash in gasoline and relubricate lightly, preferably with air compressor oil. Rings must be oily for reinsertion.
 4. Reinstall 3150G mechanism in reverse order of removal procedures. Screws 51 about a quarter turn. Replace screws 51 if stripped.

Section 3) Inspection & Cleaning of Cylinder 21.

- A) Remove 3150G mechanism as in Section 2 above.
- B) Use a flashlight to inspect bore of cylinder 21. Look for frozen oil and water film on wall. Powdery white matter is carbon dioxide snow which usually does not cause stopping.
- C) If frozen water and oil seem present, swab out cylinder with cloth on wooden stick after thawing. Do not use solvent. Cylinder 21 need not be removed from vacuum system. Allow it to thaw naturally, or put an air hose in all the way down to warm quickly by blowing. Before reinserting mechanism 3150G, very lightly oil upper cylinder walls so displacer O-rings 1 can be easily inserted.

The above procedures, when performed regularly, are usually sufficient for proper operation with average air supply. However, should difficulties recur and further repairs are necessary, continue below.

Section 4) Removal & Inspection of Valves, Inlet 16 & Outlet 15.

- A) Remove cover 17.
- B) Remove screws 51 and bumper bar 7.
- C) Remove knob 40 thus:
 - 1. Pull knob up. Back out set screw 53. Grasp rod 33 between thumb and forefinger between nylon disk 41 and plate 31. With other hand, screw knob 40 off counter-clockwise. Knob was installed at factory finger tight. If there is difficulty unscrewing knob and tools must be used, grasp rod only with wood-protected surfaces or the like.
- D) Valves 16 and 15 can be pulled all the way out, moving disk 41 out of the way as necessary.
- E) Inspect valves. They should show a very slightly oily appearance from air line oil. If they are "squeaky dry" they may jam from wear debris or may rapidly abrade and ultimately destroy the valve bores in the bronze block.
- F) The valves themselves do not wear when the air system has enough oil. They normally fall all the way in with an "oily feel" and have little play laterally when fully inserted. Design sliding clearance is .0005". If they seem too tight, it may be because of gummy deposits in the sliding clearance. Put in a little oil and work the valves up and down while rotating them until they work freely. Under good conditions of oil in the air supply, this happens naturally and valve cleaning and oiling is never necessary.
- G) Reinstall valves and knob. The outlet valve 15 has the most grooves and goes on the right.

Section 5) Drive Piston 33 Removal & Cleaning

- A) Remove mechanism 3150G as in section 2 above.
- B) Unscrew knob 40 as in section 4C above.
- C) Remove retaining screw 52 in centering plug 43. (Not in split collar 20)
- D) Grasp displacer 34 and pull displacer and attached drive piston out.
- E) Inspect rings 11, 12, 13 on drive piston. Ideally, they should be slightly oily. A little black sludge, formed by oxidation of air

line lubricating oil, does no harm providing it is soft. If there is insufficient air line oil, the sludge gets hard in the ring clearances. The rings then jam in the drive cylinder bore. It is recommended that the original teflon rings 11, 12, and steel ring 13, be removed and replaced by three ordinary buna-N rubber O-rings 5/8 O.D. x 1/2 I.D. (carried as Welch Pc. No. 41-4343). The rubber O-rings have far less tendency to make sludge than the original parts.

- F) Reinstall the drive piston 33. Be careful to not cut O-ring 2 within plate 31 as the edge of the rod 33 enters the ring. Similarly, be careful of the three rubber drive piston rings as they enter plate 36. Roughly center them by hand as they enter to avoid pinching.
- G) Reinstall the retaining screw 52 in centering plug 43.
- H) Slide a buffer 10 over protruding end of rod 33. Put on backup disk(s) 35. Put on nylon disk 41, manipulating rod 33, or valves 15 and 16 as necessary. Screw on knob 40 and tighten screw 53.
- I) Reinstall mechanism 3150G as in section 2 above.

Section 6) Rod Seal Ring Inspection & Replacement

- A) A leaky rod seal ring 2 often makes a "ripping" or "flapping" sound when worn, or when so oil-free that it is distorted by friction drag. A drop of oil where the rod comes out of plate 31 may stop the leak in the latter case. A large leak at O-ring 2 may decrease the rod in-thrust so much that the refrigerator stops.
- B) To inspect the O-ring 2 visually, remove bar 7 knob 40, disk 41, and washer 35 as described in section 5 above. Unscrew studs 5 and screws 50. Pull out valves 15 and 16. Pull off plate 31, tapping to unstick from gasket 4 if necessary. Pick out retainer disk 3 and O-ring 2.
- C) O-ring 2 should hug the rod 33 elastically. Replace the O-ring 2 if loose.
- D) When reassembling the parts be sure that the reduced diameter shoulder of disk 3 enters the 5/8" drive cylinder bore in bronze block 32. Plate 31 is retained by a quarter turn of screws 50 and studs 51 from finger tight position. Do not omit bumper 10 between plate 31 and washer 35.

If these field remedies do not correct refrigerator stoppage, then contact The Welch Scientific Company, Commercial Service Department, for further information.

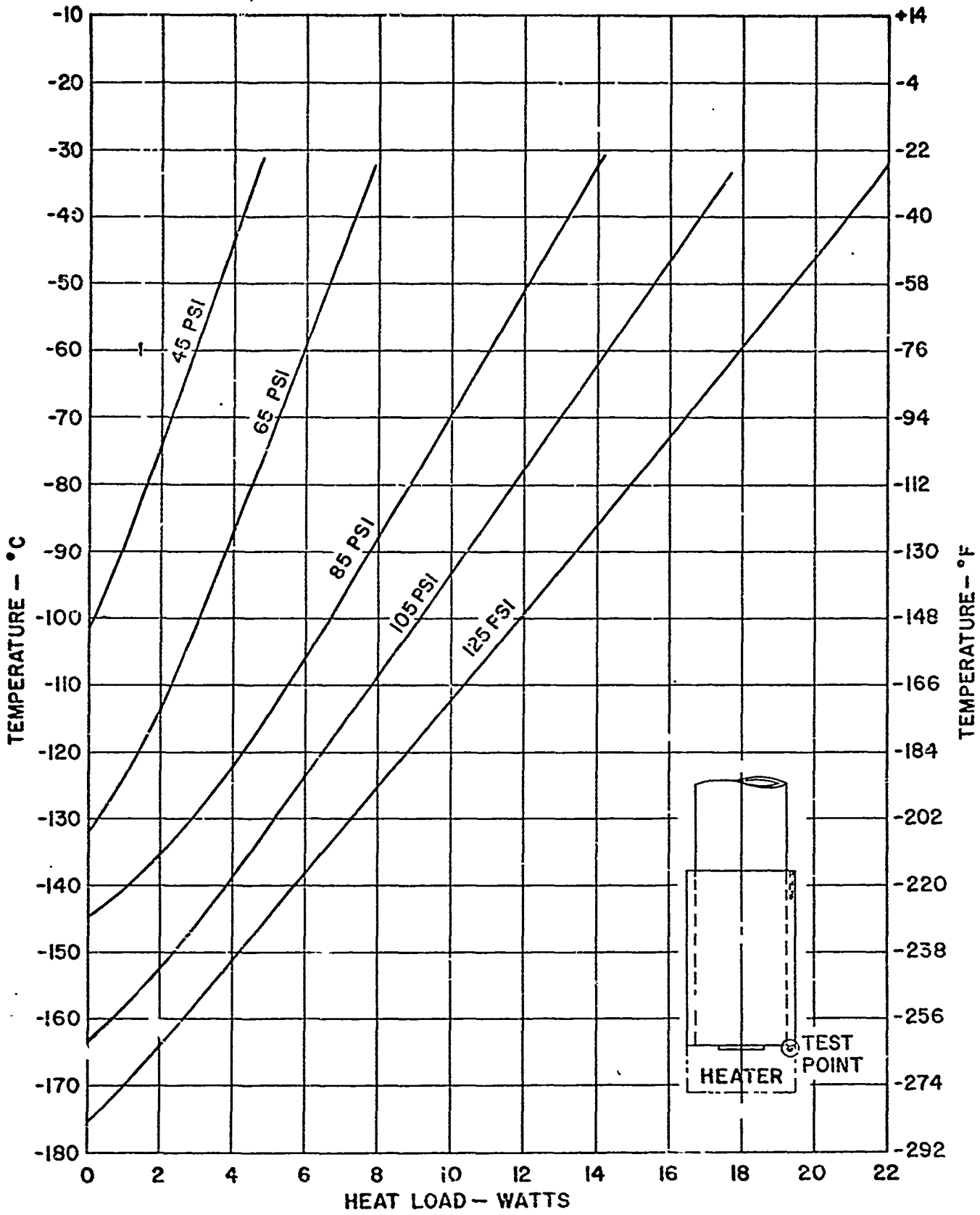

TYPICAL PERFORMANCE WELCH 3150 REFRIGERATOR







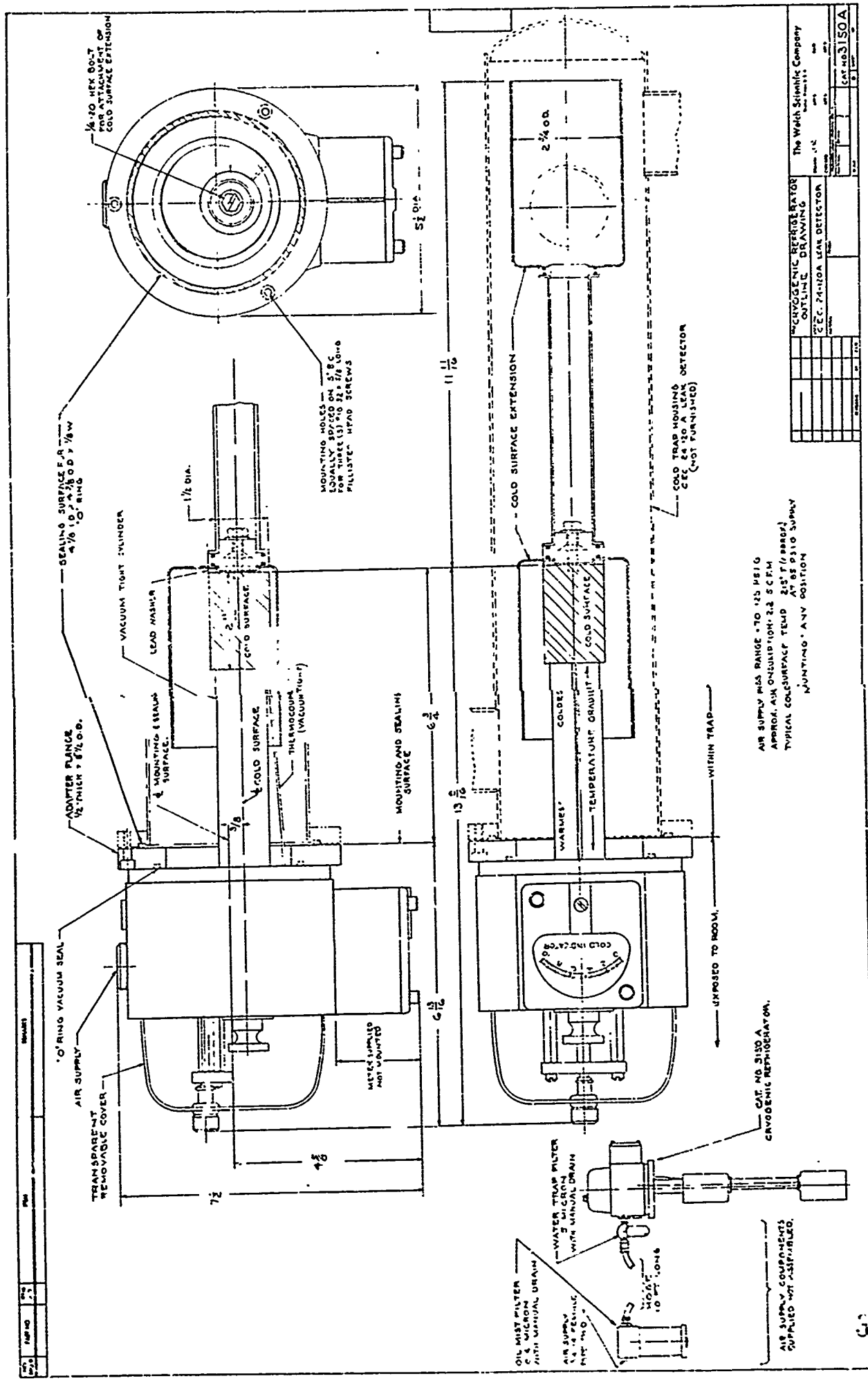

3150 CRYOGENIC REFRIGERATOR PARTS LIST

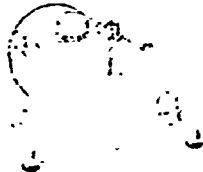
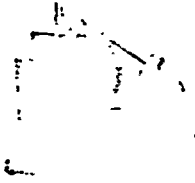
Item No.	Quan.	Pc. No.	Description
1	2	41-4402	"O" Ring, 7/8 ID x 1-1/8 OD x 1/8 W
2	1	41-4404	"O" Ring, 1/4 ID x 3/8 OD x 1/16 W
3	1	41-4503	"O" Ring Retainer
4	1	41-4504	End Plate Gasket-Front
5	3	41-4407	Stud
6	2	41-4411	Air Silencer
7	1	41-4415	Valve Stop Plate
8	1	41-4416	Inspection Cover Screw
9	1	41-4417	Lubricator Felt
10	2	41-4419	End Buffer
11	2	41-4420	Piston Wear Ring
12	1	41-4421	Piston Seal Ring (Outer)
13	1	41-4422	Piston Seal Ring (Inner)
14	1	41-4424	Pilot Valve
15	1	41-4425	Supply Valve
16	1	41-4426	Early Cut-Off Valve
17	1	41-4427	Inspection Cover
18	1	41-4502	Retainer Ring
19	1	41-4431	Hose Assembly--10 Ft. Long
20	1	41-4433	Split Collar
21	1	41-4437	Cylinder Assembly
22	1	41-4438	Cylinder Flange Gasket
23	1	41-4440	Thermo Couple
24	1	41-4471	Air Connection Assembly
25	1	41-4444	Thermo Couple Clip
26	1	41-4445	"O" Ring, 5/32 ID x 9/32 OD x 1/16 W
27	1	41-4537	Oil Mist Filter (Replacement Element is Pc.No. 41-4528)
28	1	41-4449	Water Trap Filter
29	1	41-4451	Retaining Ring
30	1	41-4452	Grommet
31	1	41-4505	End Plate Assembly (Front)
32	1	41-4456	Motor Block Assembly
33	1	41-4457	Drive Piston & Rod Assembly
34	1	41-4459	Regenerator-Displacer Piston Assembly
35	1	41-4460	Back-Up Washer
36	1	41-4506	End Plate Assembly (Back)
37	1	41-4462	Cold Trap Housing Assembly
38	1	41-4463	Cold Indicator Meter Assembly
39	1	41-4465	"O" Ring, 3/16 ID x 5/16 OD x 1/16 W
40	1	41-4466	Manual Starter Button
41	1	41-4467	Valve Actuator Disc
42	1	41-4468	Reducer Bushing 3/4 NPT x 1/4 NPT
43	1	41-4469	Centering Plug
44	1	41-4470	Flare Connector Body
45	1	41-4472	Compression Connector Body
46	1	41-4507	End Plate Gasket-Back
47	1	41-4490	Lead Washer
48	1	41-4495	Cold Surface Extension Assembly
Not shown	1	41-4496	Cold Surface Extension Assembly for Model 3150A
Not shown	1	41-4497	Cold Surface Extension Assembly for Model 3100B
49	6	2-00-2606	Fil.Hd.Steel Machine Screw NP #8-32 x 3/8 LG.
50	6	2-00-2706	Fil.Hd.Steel Machine Screw NP #10-32 x 3/8 LG.
51	7	2-00-2708	Fil.Hd.Steel Machine Screw NP #10-32 x 1/2 LG.
52	6	2-20-6304	Socket Hd.Stainless Steel Cap Screw #4-40 x 1/4 LG.
53	1	2-00-9603	Socket Steel Set Screw NP #8-32 x 3/16 LG.
54	1	41-4443	Throttling Screw
55	1	41-4498	Washer
56	1	41-4491	Slotted Bolt
57	1	2-40-3607	Hex Nut 8-32

→ Replace with 3 rubber "O"
Rings, 5/8 OD x 1/2 ID,
Pc. No. 41-4343

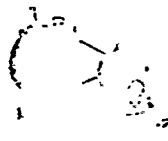

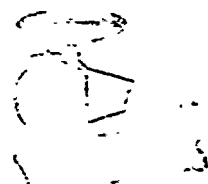
REV		DATE	BY	CHKD
CRYOGENIC REFRIGERATOR OUTLINE DRAWING				
The Welch Scientific Company				
220 E. 74th St. New York 17, N.Y.				
CAT. NO. 3130 A				

 <p>MODEL 1398M 1 x 10⁻⁴ Torr 1500 lpm (53 cfm)</p>	 <p>MODEL 1397B 1 x 10⁻⁴ Torr 500 lpm (17.7 cfm)</p>
 <p>MODEL 1375S 1 x 10⁻⁴ Torr 300 lpm (10.6 cfm)</p>	 <p>MODEL 1402B 1 x 10⁻⁴ Torr 160 lpm (5.6 cfm)</p>
 <p>MODEL 1405B 1 x 10⁻⁴ Torr 60 lpm (2.1 cfm)</p>	 <p>MODEL 1400B 1 x 10⁻⁴ Torr 25 lpm (0.9 cfm)</p>
 <p>MODEL 1403B 5 x 10⁻² Torr 100 lpm (3.5 cfm)</p>	 <p>MODEL 1399B 1.5 x 10⁻² Torr 35 lpm (1.2 cfm)</p>
 <p>MODEL 1404H 2 x 10⁻² Torr 33.4 lpm (1.2 cfm)</p>	 <p>MODEL 1410N 2 x 10⁻² Torr 21 lpm (0.7 cfm)</p>
 <p>MODEL 1392 1 x 10⁻⁴ Torr 25 lpm (0.9 cfm)</p>	 <p>MODEL 3102D 1-2 x 10⁻² Torr 200 lpm</p>

Reproduced from
best available copy.

PICK THE
WELCH



VACUUM
PUMP

THAT FITS
YOUR NEEDS

Write for Duo-Seal Catalog

7300 N. NORTH LINCOLN AVENUE • SKOKIE, ILLINOIS 60076

APPENDIX B
LIST OF DRAWINGS

D-12897	Cryogenic Hygrometer (Sterling) Interface Drawing
B-16423	Cable Interconnection Aircraft Hygrometer
C-16282	Model 196 Fast TC Hygrometer -100°C to $+50^{\circ}\text{C}$, Configuration Control Drawing
B-16426	Cable W2 Remote Head to Control Panel
B-16424	Cable W1 Remote Head to Control Panel
B-16427	Cable "E" Control Panel to Recorder
E-16551	Aircraft Hygrometer, Model 196 Schematic
D-16289	Aircraft Hygrometer Temperature Circuit Schematic, Model 196

DWG CLASS
CROSS INDEX

CONTROL PANEL

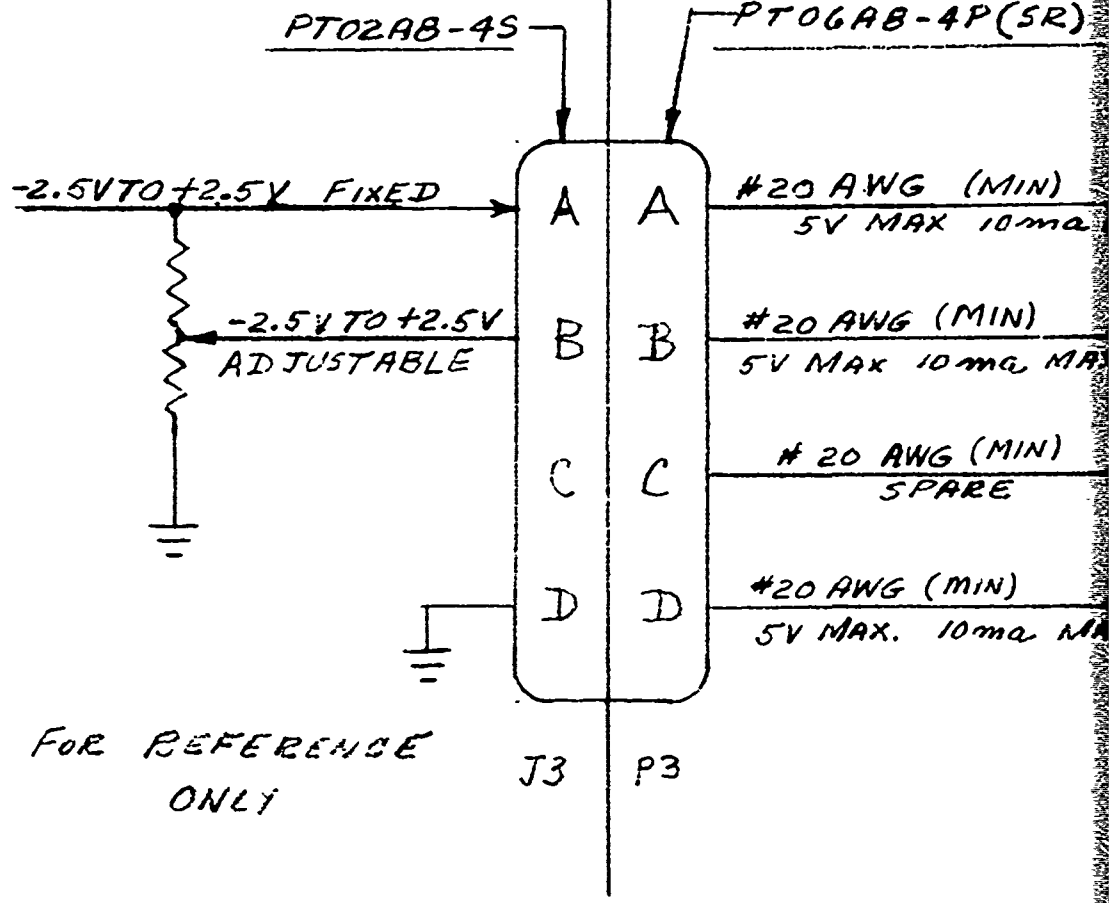

FOR REFERENCE ONLY

			UNLESS OTHERWISE SPECIFIED: REFER TO PROCESS STANDARDS 41001 AND 41002 DIMENSIONS ARE IN INCHES TOLERANCES ON HOLES FRACTIONS DECIMALS ANGLES ± ± ± ±	SCALE
			UNLESS OTHERWISE SPECIFIED: RESISTANCE VALUES ARE OHMS = % WATT CAPACITANCE VALUES ARE IN FARADS = % VOLTS DIODES ARE TYPE TRANSISTORS ARE TYPE	FINISH
DASH NO.	NEXT ASSY	USED ON		
APPLICATION				
			DO NOT SCALE PRINT	

3 2 1

REVISIONS				
ZONE	LTR	DESCRIPTION	DATE	APPROVED
	A	INITIAL RELEASE		

P(SR)

(MIN) →
10ma MAX

(IN) →
ma MAX

(MIN) →
E

(IN) →
ma MAX.

CUSTOMER SUPPLIED
RECORDER

C

B

←

MATERIAL: +	DRAWN <i>Alm...</i>	DATE 3/5/71	 EODG INTERNATIONAL GEODYNE DIVISION WALTHAM, MASS.			
	CHECKED	DATE				
FINISH SPECS: +	DESIGNER	DATE	CABLE "E" CONTROL PNL. TO RECORDER AIRCRAFT HYGROMETER			
	ENGINEER	DATE				
	PROJECT ENGINEER	DATE	SIZE B	CODE IDENT NO. 07926	TYPE 16427	REV A
	PROJECT APPROVAL	DATE	SCALE —	SHEET —		

3 2 1

5

4

3

DWG CLASS

CROSS INDEX

REMOTE HEAD

PT06SE14-185 (SR)

PT00

0-1ma (M)



REFERENCE JUNCTION

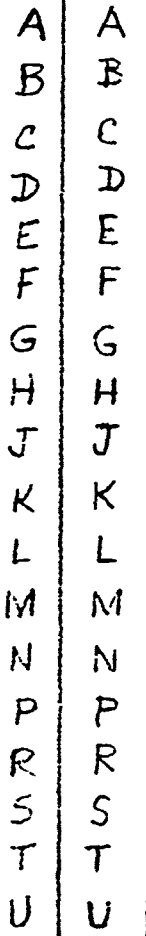

- METER INDICATION #20AWG 10V MAX., 10ma
- SPACE #20AWG (MIN)
- LAMP DRIVE 15V MAX., 1AMP MAX.
- HEATER DRIVE LINES 15V MAX. 3AMP MAX
- #20AWS REFERENCE JUNCTION, POWER SWITCH 10V MAX.
- PHOTOCELL PICKUP 15V MAX. 10ma MAX.
- SPACE #20AWG (MIN)

CABLE W3 SUPPLIED BY E.G.G.

PT02A14-18P J12 P12

MICRO HEATER



COLD SINK THERMISTOR RT

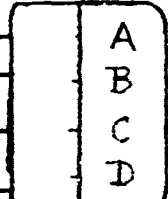

J7 P7

SHOWN FOR REFERENCE ONLY

			UNLESS OTHERWISE SPECIFIED: REFER TO PROCESS STANDARDS 41001 AND 41002 DIMENSIONS ARE IN INCHES TOLERANCES ON HOLES FRACTIONS DECIMALS ANGLES ± ± ± ± ± ± ± ±
			UNLESS OTHERWISE SPECIFIED: RESISTANCE VALUES ARE OHMS = % WATT CAPACITANCE VALUES ARE IN FARADS = % VOLTS DIODES ARE TYPE TRANSISTORS ARE TYPE
DASH NO.	NEXT ASSY	USED ON	
APPLICATION			

MOD 196

DO NOT SCALE PRINT

5

4

3

3 B 2 1

REVISIONS			
ZONE	LTR	DESCRIPTION	DATE
	A	PRODUCTION RELEASE	

PT. 065E-14-18P(SR)

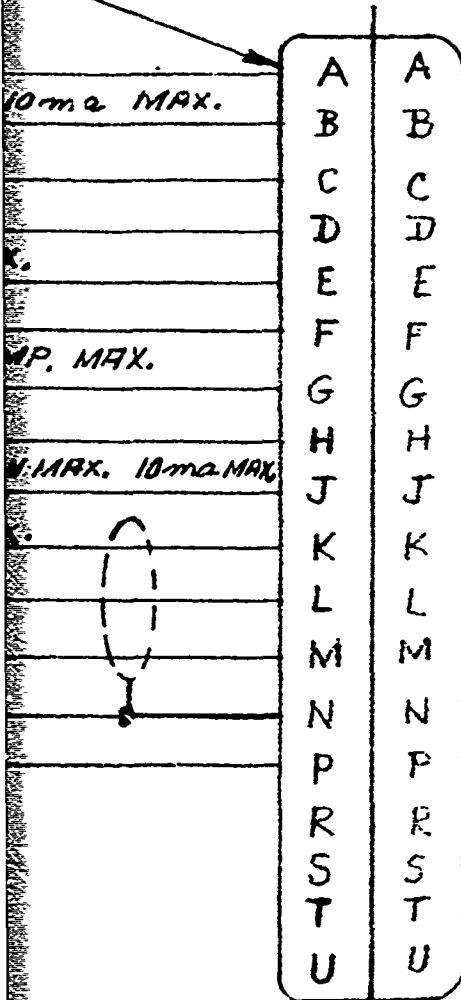

PT. 025E14-185

CONTROL PANEL

P1 | J1

DRAWN <i>Abraham</i>	DATE 3/4/71	EODG INTERNATIONAL GEODYNE DIVISION WALTHAM, MASS.
	CHECKED	
DESIGNER	DATE	CABLE W2 REMOTE HEAD TO CONTROL PANEL AIRCRAFT HYGROMETER
ENGINEER	DATE	
PROJECT ENGINEER	DATE	SIZE B CODE IDENT NO. 07926 TYPE A3 16426 REV A
PROJECT APPROVAL	DATE	SCALE H SHEET H

3 2 1

REVISIONS				
ZONE	LTR	DESCRIPTION	DATE	APPROVED
	A	PRODUCTION RELEASE		

REVISIONS

SE12-10P(SR)

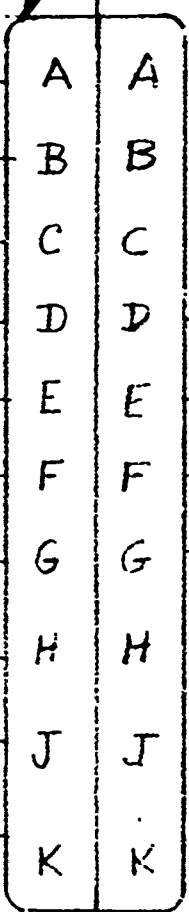

LINEARIZER

SPARES

SHOWN FOR REFERENCE ONLY

P2

J2

CONTROL PANEL

DRAWN <i>atkinson</i> CHECKED DESIGNER ENGINEER PROJECT ENGINEER PROJECT APPROVAL	DATE DATE DATE DATE DATE	EDG INTERNATIONAL GEODYNE DIVISION		WALTHAM, MASS.				
		CABLE W1 REMOTE HEAD TO CONTROL PANEL AIRCRAFT HYGROMETER				SIZE B	CODE IDENT NO. 07926	TYPE A3
MATERIAL: FINISH SPECS:		SCALE <i>H</i>		SHEET <i>H</i>				

3

B

2

1

REVISIONS				
ZONE	LTR	DESCRIPTION	DATE	APPROVED
	A	INITIAL RELEASE		

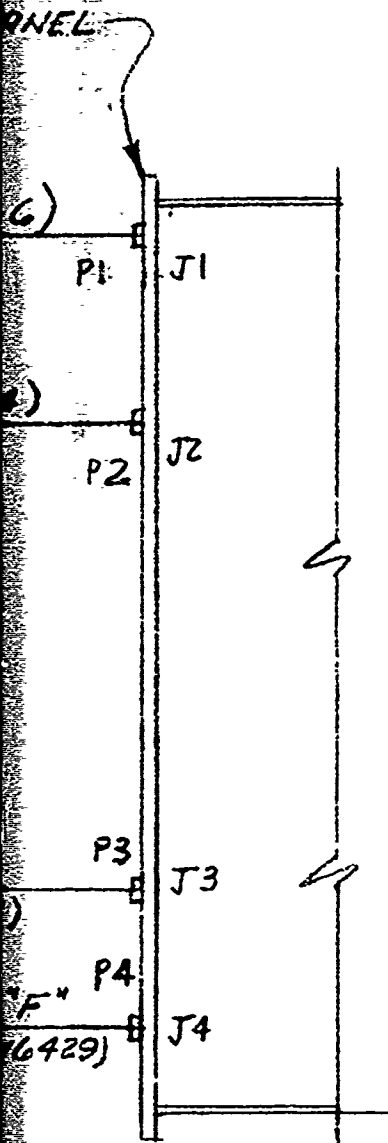

NOTE:
1. CABLES C, W3&F SUPPLIED BY E.G&G.

EQUIPMENT

MATERIAL: —	DRAWN <i>Robert L...</i>	3/5 DATE	 EOG INTERNATIONAL GEODYNE DIVISION		WALTHAM, MASS.
	CHECKED	DATE	CABLE INTERCONNECTION		
FINISH SPECS: —	DESIGNER	DATE	PIRCRAFT HYGROMETER		
	ENGINEER	DATE	SIZE	CODE IDENT NO.	TYPE
	PROJECT ENGINEER	DATE	B	07926	16423
	PROJECT APPROVAL	DATE	SCALE	SHEET	
					REV A

3

2

1

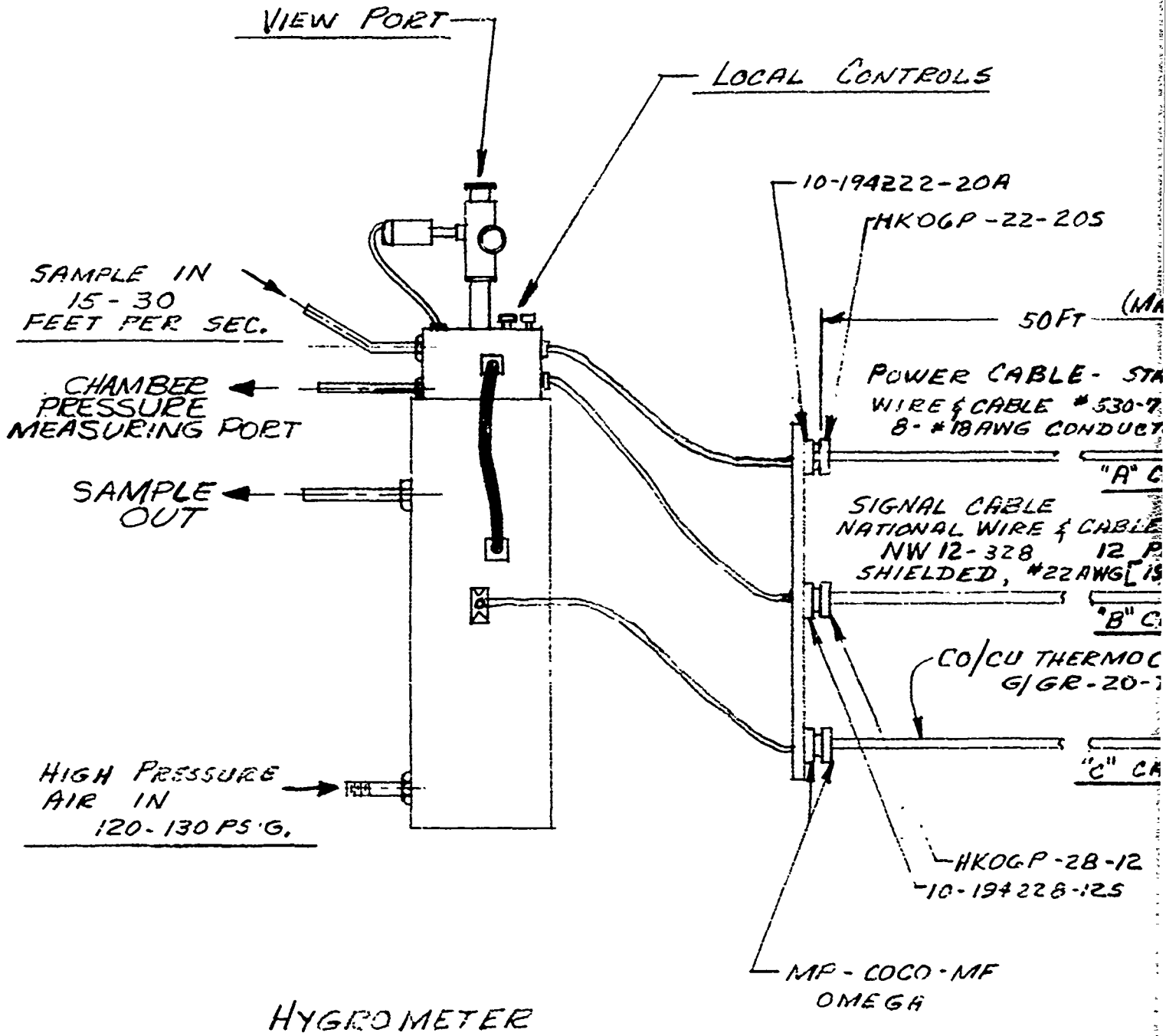

NOTE: UNLESS OTHERWISE SPECIFIED

B



2

R		DESCRIP
ZONE	LTR	
	A	

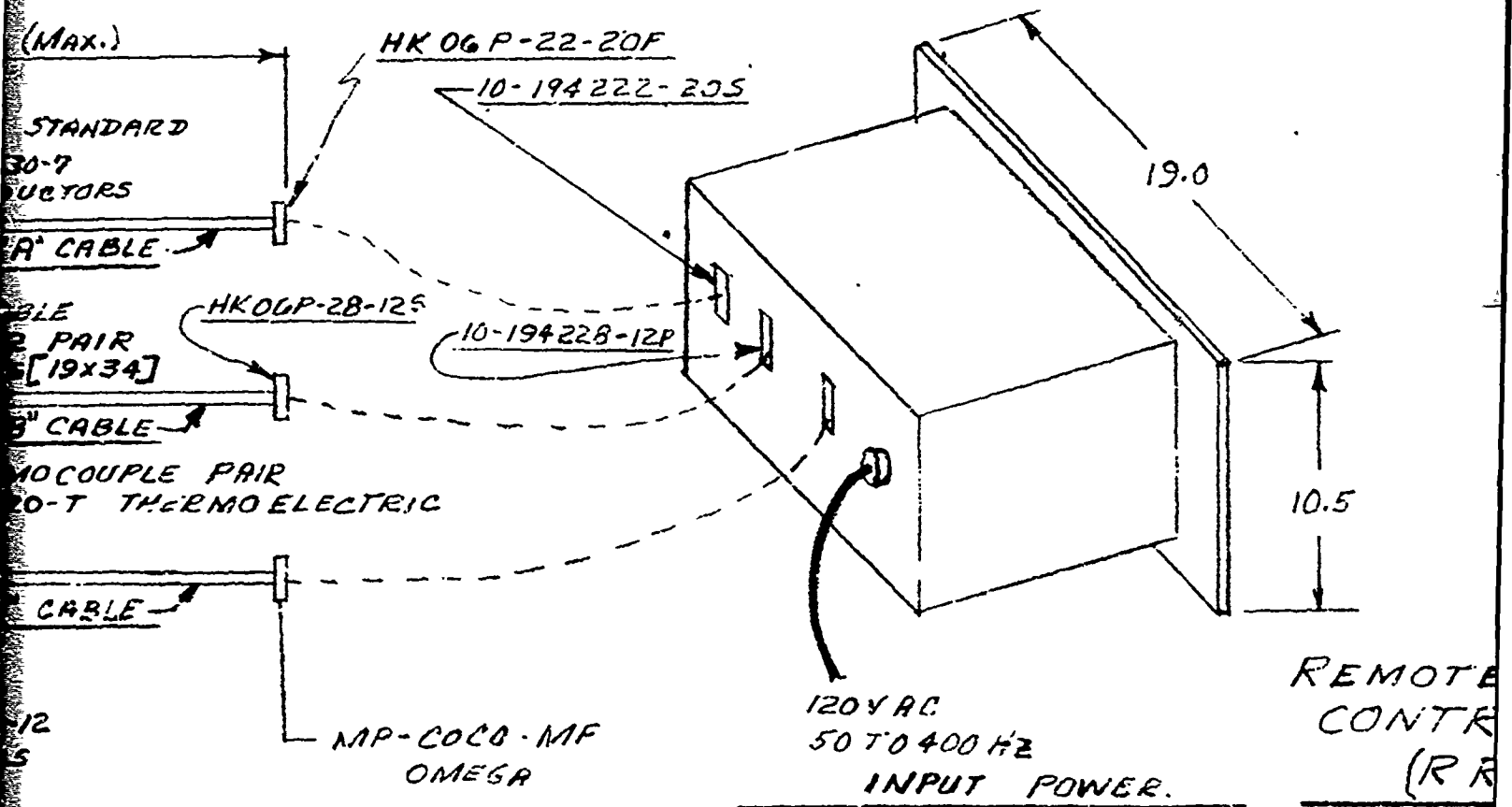

INSERT #22-20
"A" CABLE

INSERT #28-12
"B" CABLE

- A- #1
- B 2
- C 3
- D 4
- E 5

- A } DRAIN (GND)
- B }
- C } PAIR #1
- D }
- E } #2
- F }

- R } PAIR #7
- S }
- T }
- U }
- V }
- W }

2

1

REVISIONS

ZONE	LTR	DESCRIPTION	DATE	APPROVED
	A			

APPROVED
12-21

D

C

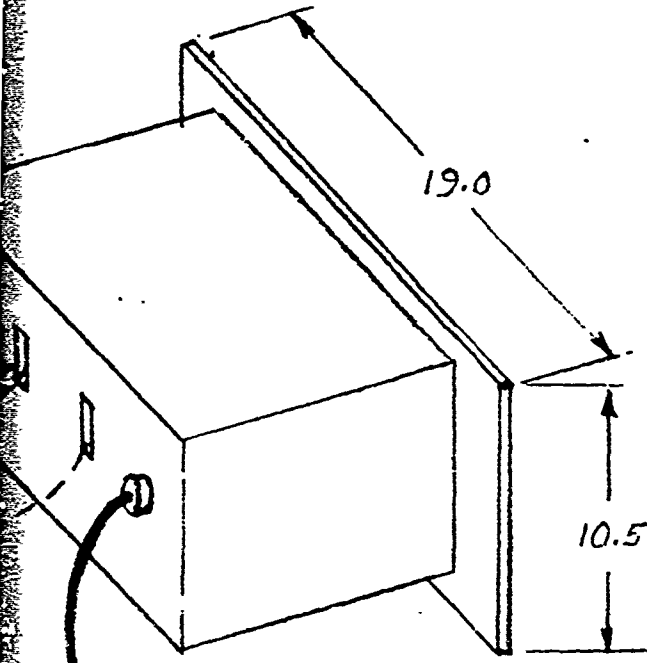

120V AC
50 TO 400 HZ
INPUT POWER.

REMOTE READOUT
CONTROL UNIT
(RRCU)

INSERT #28-12
"B" CABLE

"C" CABLE

(GND)	R	S	T	U	V	W	PAIR	#
1								7
								8
2								9

CU - CU
CO - CO

B

SAMPLE
OUT

SIGNAL CABLE
NATIONAL WIRE & CABLE
NW 12-328 12 P
SHIELDED, #22 AWG [15

"B" C

CO/CU THERMO
G/GR-20-

"C" C

HIGH PRESSURE
AIR IN
120-130 PSIG.

HKOGP-28-12
10-194228-125

MP-COCO-MF
OMEGA

HYGROMETER

NOTE:
1. UNLESS OTHERWISE SPECIFIED
CONNECTORS ON CABLE BETWEEN
HYGROMETER & RRCU ARE BENDIX CORP.

D'G CLASS				UNLESS REFER TO 41 DIMENS T HOLES FRAC = ~ =
	DASH NO	NEXT ASSY	USED ON	UNLESS RESISTA OHMS = CAPACIT FARADS DIODES TRANSIS
CROSS INDEX	APPLICATION			
				DO N

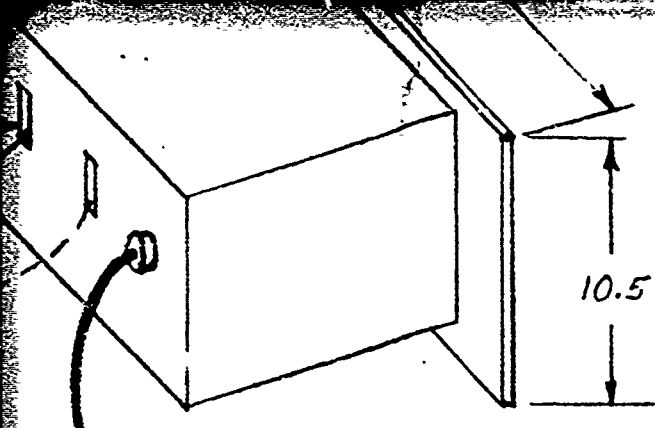

120V AC
50 TO 400 HZ
INPUT POWER.

REMOTE READOUT
CONTROL UNIT
(RRCU)

INSERT #28-12
"B" CABLE

"C" CABLE

(GND)		PAIR	#
#1	R	} PAIR	#7
	S		#8
#2	U		#9
	V		#10
#3	X		#11
	Y		#12
#4	Z		
	a		
#5	b		
	c		
#6	d		

CU - CU
CO - CO

C

B

A

DRAWN	A. R. HANCOCK	DATE	12/11/70
CHECKED		DATE	
DESIGNER		DATE	
ENGINEER		DATE	
PROJECT ENGINEER		DATE	
PROJECT APPROVAL		DATE	

EG&G
ENVIRONMENTAL EQUIPMENT DIVISION WALTHAM, MASS.

CONFIGURATION CONTROL DRAWING
-100°C TO +50°C
FAST TC HYGROMETER
MODEL 126

SIZE	CODE IDENT NO.	TYPE	REV
C	07926		A
SCALE		SHEET	
H		—	

2

F

1

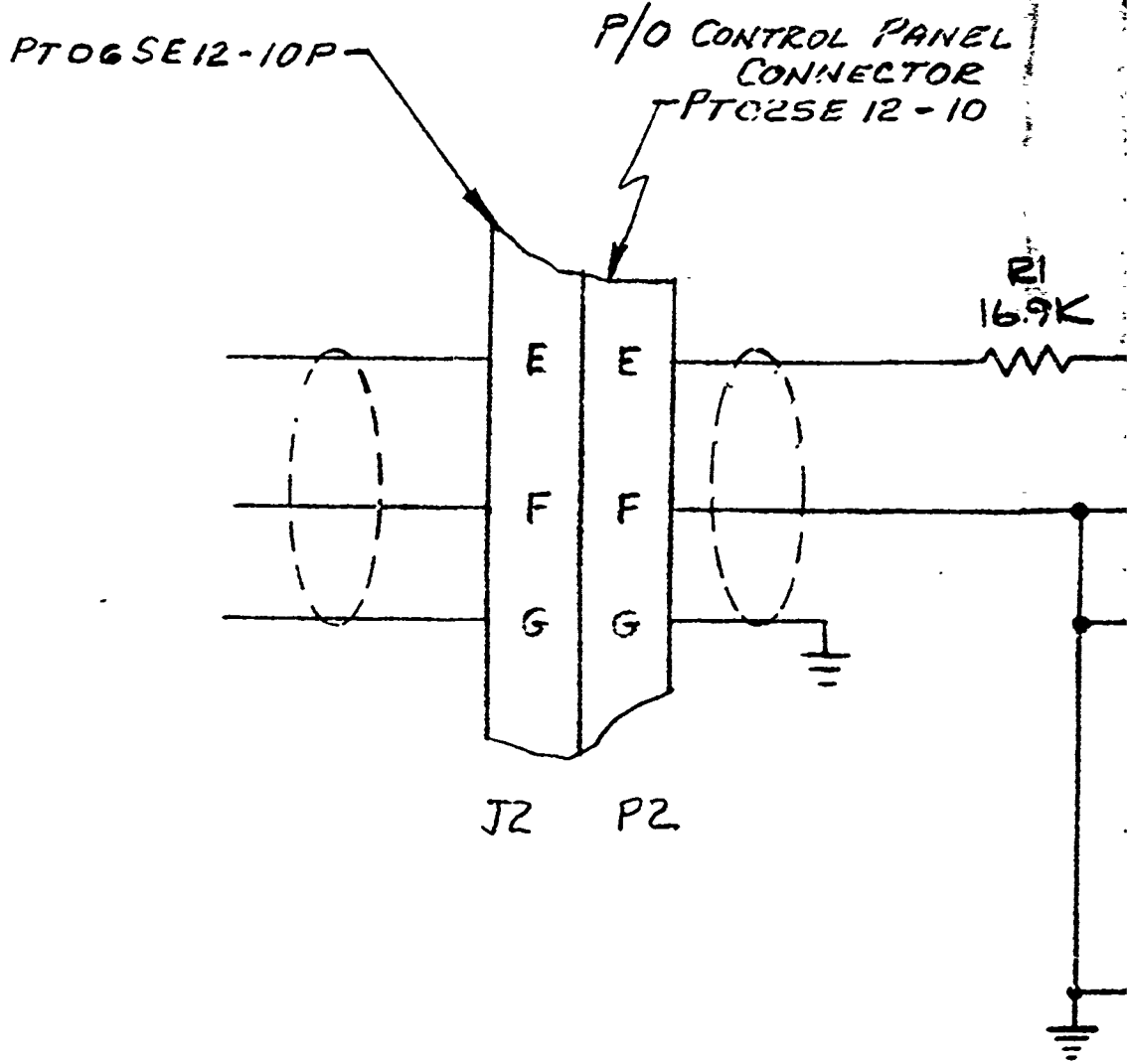

CALIBRATION:

1. SHORT PIN(S) E & F OF P2 AND SET TRIM BE OUT. (DISCONNECT R31 51.1 MEG AND SHORT C2)
2. WITH POWER SUPPLY SET TO $\pm 18V \pm 0.05V$ SET 8.75 VOLTS ACROSS THE SEVEN RESISTORS R2
3. WITH L & N POTENTIOMETER SIMULATING THE TH AT THE INPUT, SET IT FOR $-100^{\circ}C$ AND ADJUST Z6 0.00 VOLTS OUTPUT OF A2. ALSO SET MECHANICAL
4. MAKE THE FOLLOWING ADJUSTMENTS IN ORDER

RESISTOR

INPUT TEMP. °C

R3
R14

-90.625
-71.875
-53.125

A

B

6

5

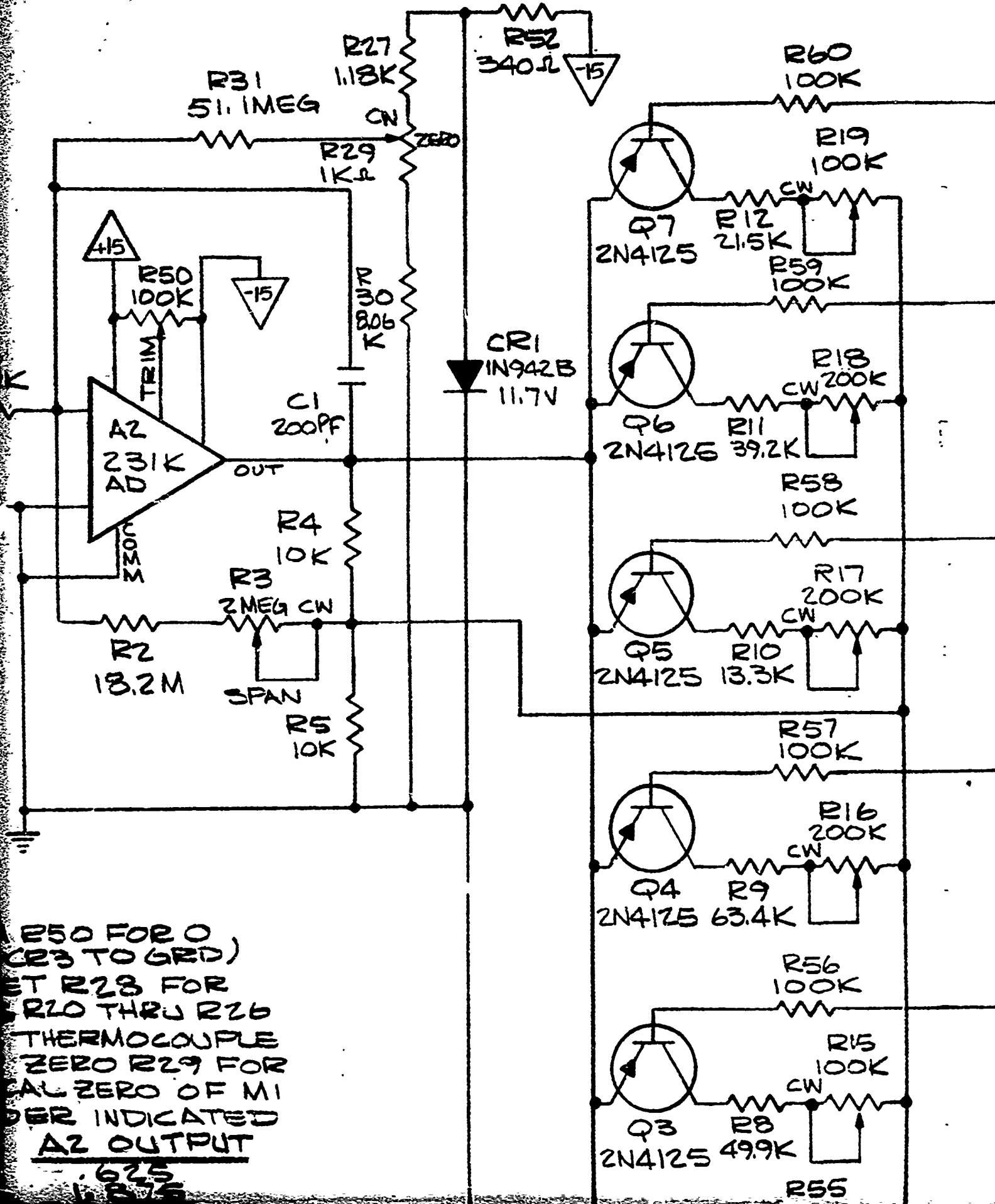

R50 FOR 0
 (R23 TO GND)
 SET R28 FOR
 R20 THRU R26
 THERMOCOUPLE
 ZERO R29 FOR
 CAL ZERO OF MI
 GBR INDICATED
 A2 OUTPUT

625
 1.875

C

4

3

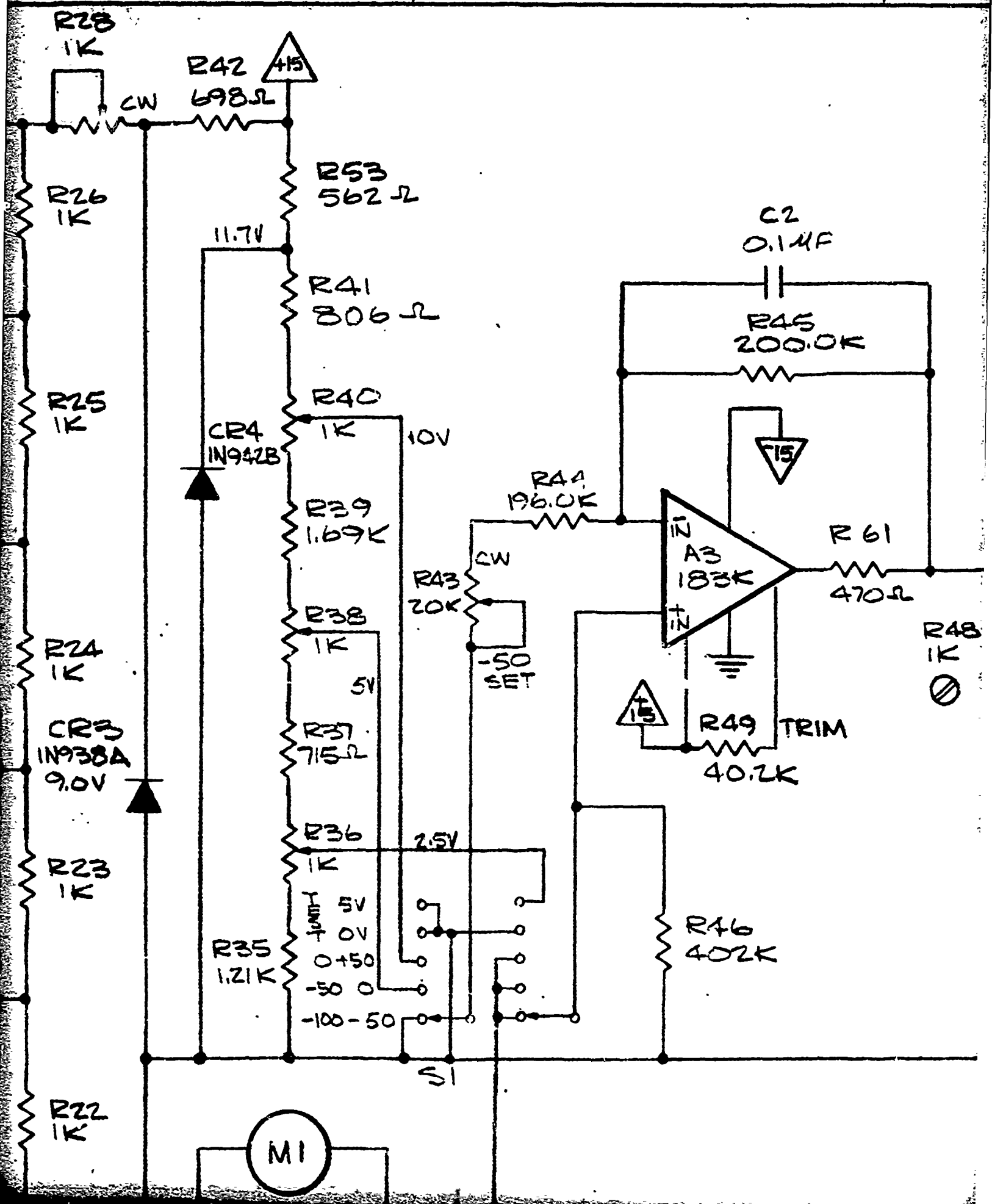

R28
1K

R42
698Ω

△15

R26
1K

R53
562Ω

11.7V

C2
0.1μF

R25
1K

R41
806Ω

R45
200.0K

CR4
1N942B

R40
1K

▽15

10V

R44
196.0K

R39
1.69K

A3
183K

R61
470Ω

R43
20K

-50
SET

R48
1K

R24
1K

CR3
1N938A
9.0V

R38
1K

5V

R37
715Ω

R49 TRIM
40.2K

R36
1K

2.5V

R35
1.21K

5V
0V
0+50
-50
-100-50

R46
402K

R22
1K

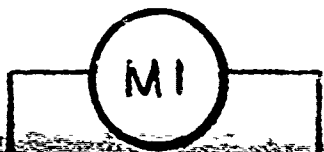

S1

D 2

1

REVISIONS

ZONE	LTR	E.C.O. NO.	DESCRIPTION	DATE	APPROVAL
	A		INITIAL RELEASE		
	B				

[Handwritten initials]

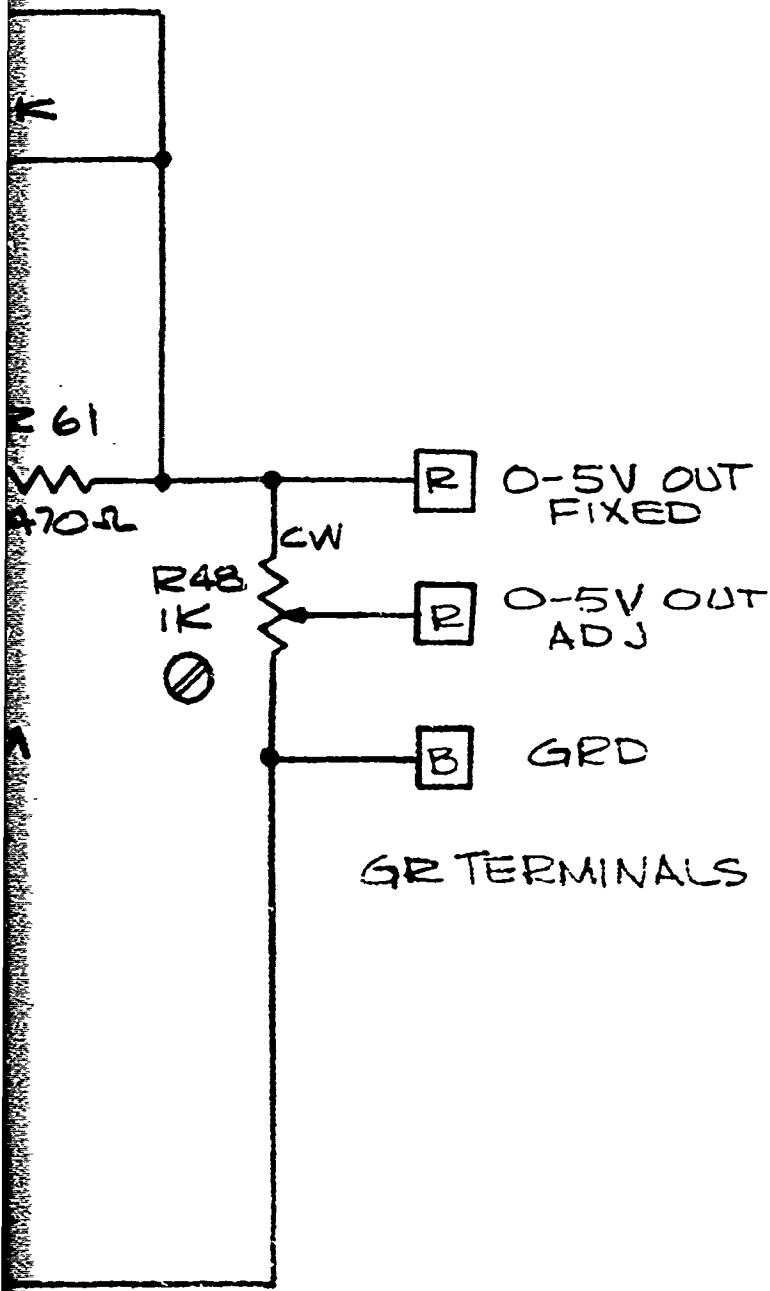

D

C

R14
R15
R16
R17
R18
R19

- 55.125
- 34.375
- 15.625
+ 3.125
+ 21.875
+ 50.000

5. WITH INPUT SET TO $+50^{\circ}\text{C}$ SET R33 FOR $+5$
6. WITH SI IN $-100 - 50$ POSITION AND -100 FOR 0.00V OUT,
7. WITH -50°C INPUT SET R43 FOR 5.00V O
8. WITH SI IN $-50, 0$ POSITION, SET R38 FOR CHECK OUTPUT FOR 500V WITH 0°C INP.
9. WITH SI IN $0 +50^{\circ}\text{C}$ POSITION AND 0°C FOR 0V OUT, CHECK 5.00V OUT WITH $+50$
10. WITH SI AT 0V TEST CHECK OUTPUT FOR
11. WITH SI AT 5V TEST SET R36 FOR

NOTES:

1. ALL RESISTORS WITH DECIMAL POINTS OTHERS ARE 5% $1/4\text{W}$ UNLESS OTHERWISE

B

A

5.125
 4.875
 5.625
 6.875
 8.125
 10.000
 10°C ON METER
 IC INPUT CHECK

OUT
 0.00V OUT,
 INPUT SET R40
 IC INPUT,
 0V
 5.00V OUT

ARE 1% RN65D,
 NOTED

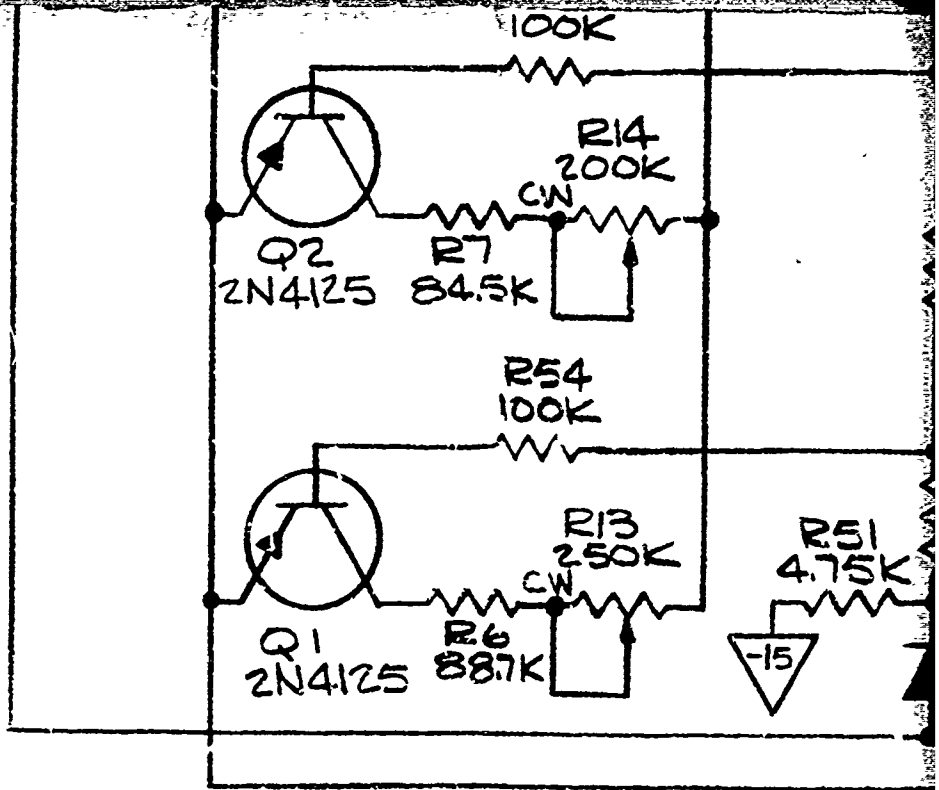

F



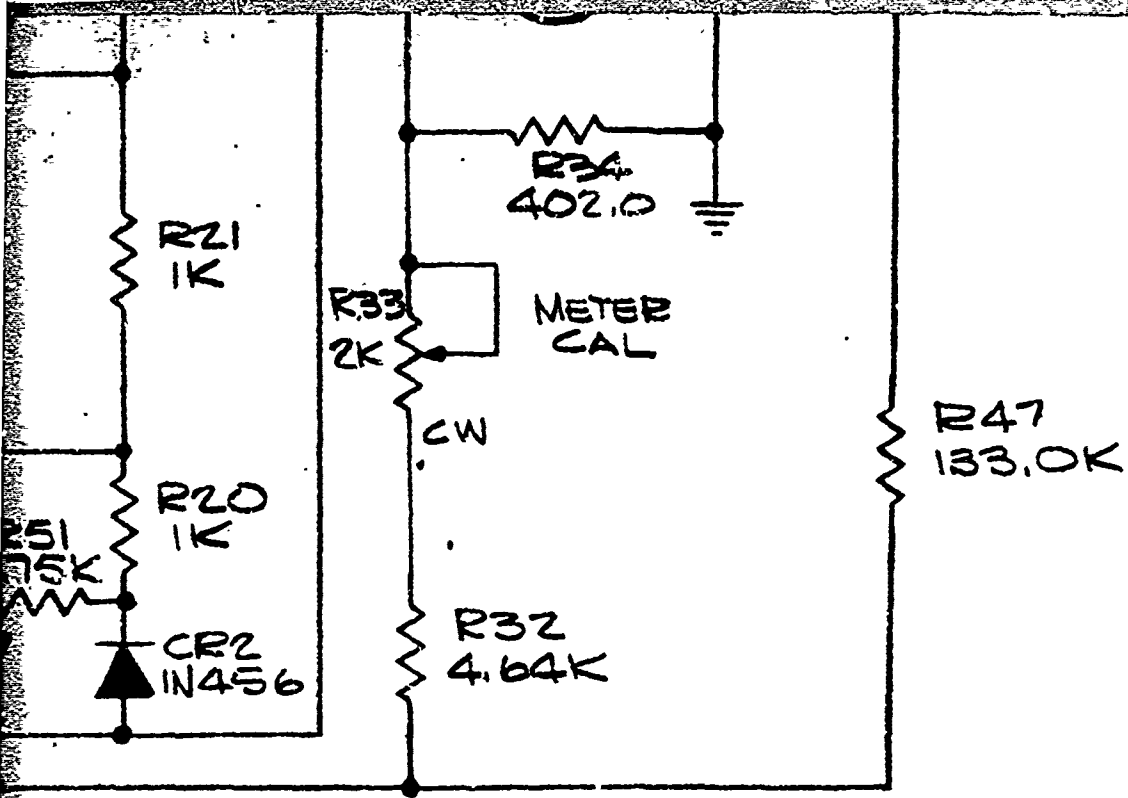

REMOVE BURRS, BREAK ALL SHARP EDGES .005 MAX		UNLESS OTHERWISE SPECIFIED DIMENSIONS ARE IN INCHES. TOLERANCES: SURF. ROUGHNESS .XX + .XXX ++ ANGLES +- EXCEPT AS NOTED	QTY
			REQ
		MATL	DR
		FINISH	CHK
NEXT ASSY		USED ON	A
APPLICATION			P
			D

6

B

QTY REQD	PART OR IDENT NO.	DESCRIPTION	ITEM NO.
PARTS LIST			
DR <i>[Signature]</i> <i>29 Dec 70</i> CHK APP D		CAMBRIDGE SYSTEMS OPERATION NEWTON MASSACHUSETTS	A
		AIRCRAFT HYGROMETER TEMP. C'KT SCHEMATIC MODEL 196	
		SIZE D CODE IDENT NO. 22905	16289
		REV B	
		SCALE	SHEET OF

D

8

7

BENDIX CONNECTOR
 D-194228-125

**MICROSCOPE LIGHT
 INTENSITY CONTROL
 KNOB**

**CONTROL CONDITION
 METER**

BALANCE KNOB

**CONNECTOR FOR
 MICROSCOPE LIGHT**

7.50
 DIA. REF

2.00
 MAX.

45°

10.00
 DIA.

7.50
 DIA. MAX

10.00
 MAX

A

D

C

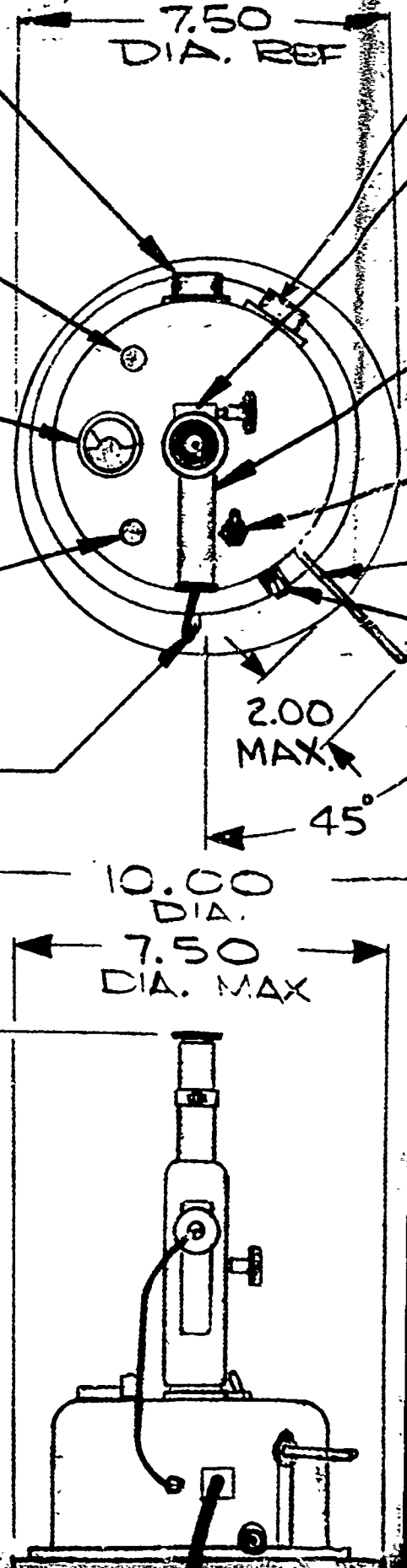

B

6

5

BENDIX CONNECTOR
10-19422-20A



MICROSCOPE

MICROSCOPE LIGHT

BENDIX CONNECTOR
10-194222-205

CONTROL SWITCH
COOL-OFR-TEST

SAMPLE INLET
1/4 INCH TUBING

PRESSURE TAP FOR
MEASURING PRESSURE
IN SENSING CHAMBER
SWAGELOK FITTING
(1/8 INCH)



BENDIX CONNECTOR
10-194228-12F

7.50
DIA. REF

2.00
MAX

45°

10.00
DIA.

7.50
DIA. MAX

REF
CUSTOMERS PANEL

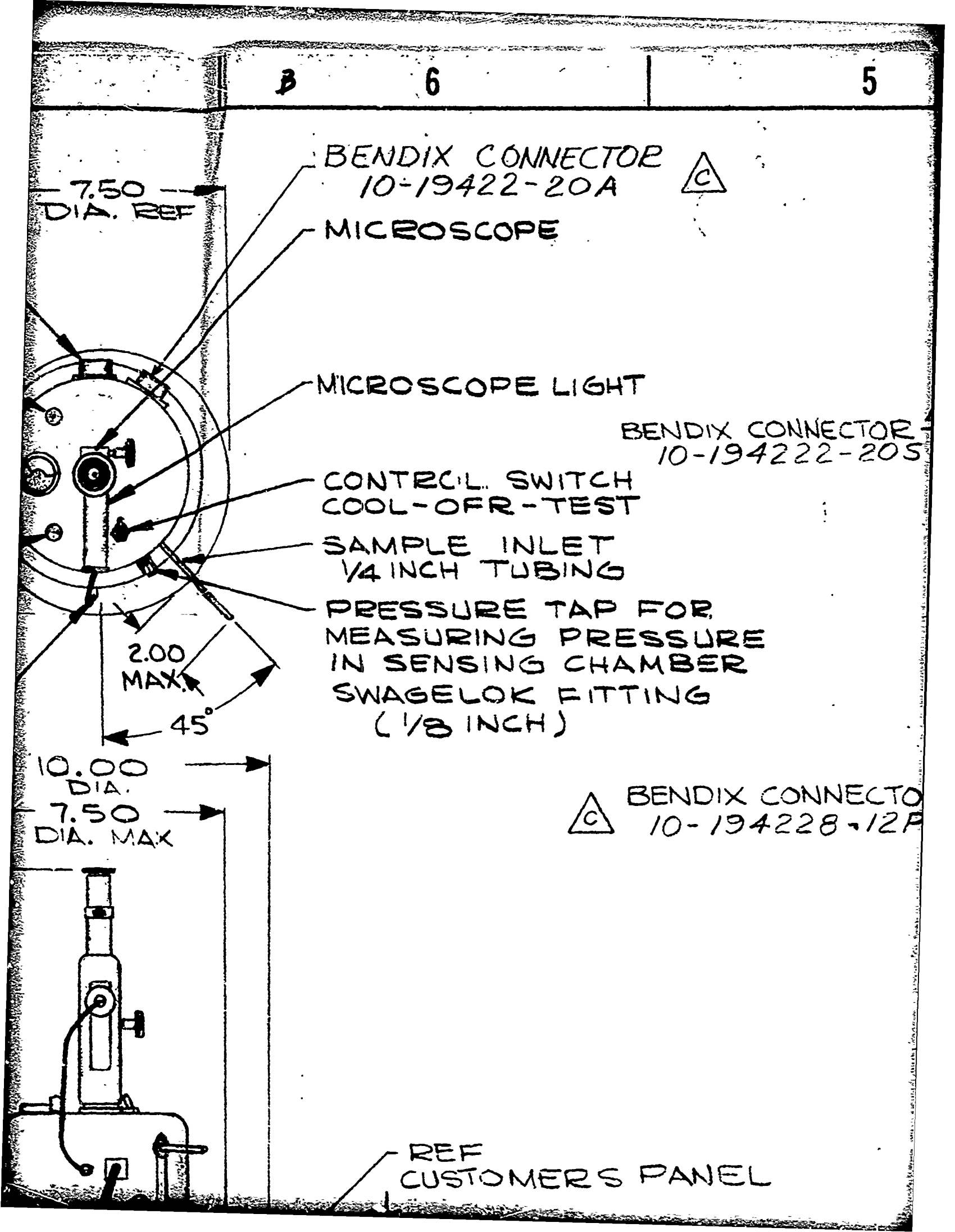

5

4

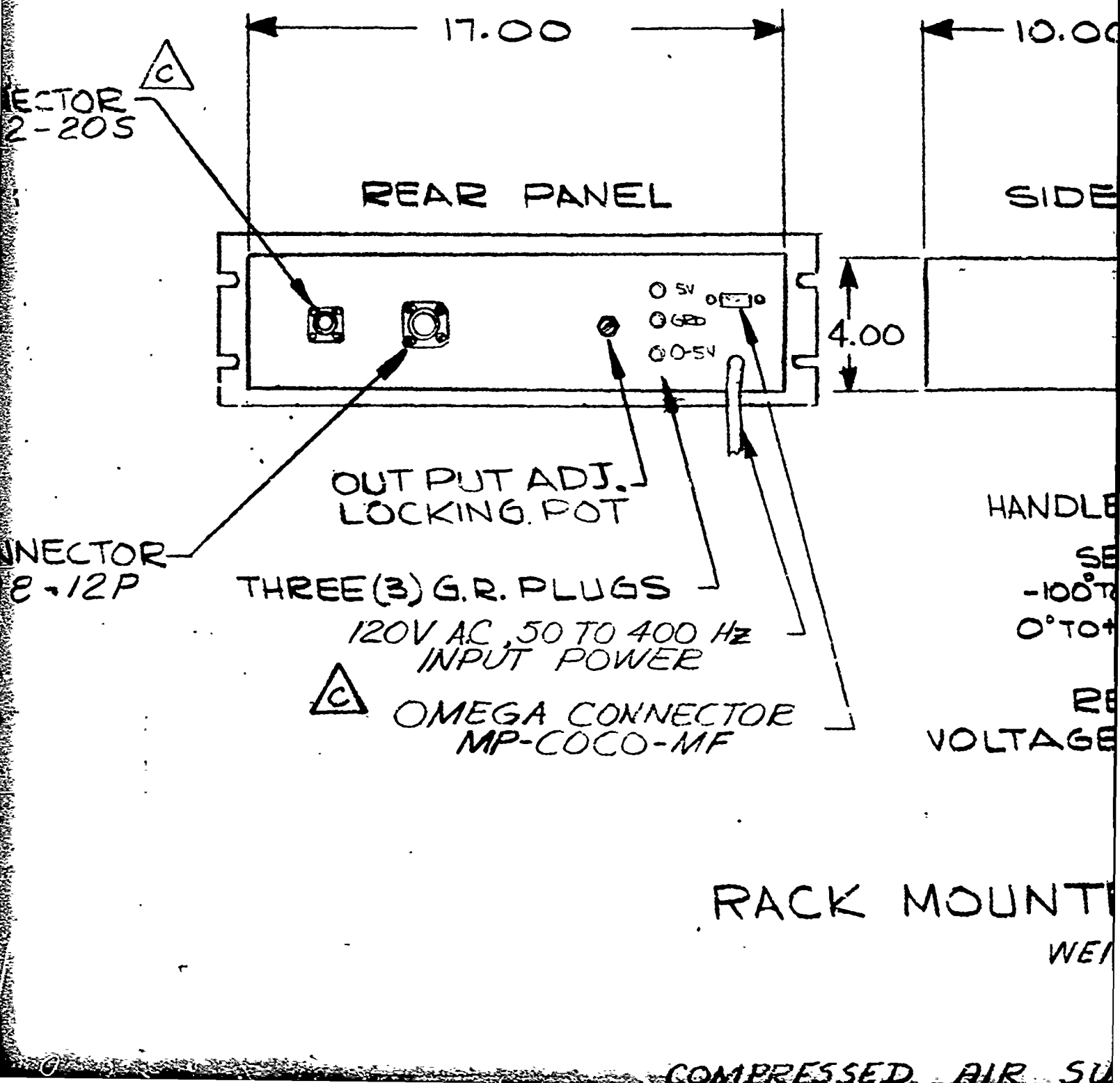

REVISIONS			
ZONE	LTR	E.C.O. NO.	DESCRIPTION
	A		INITIAL RELEASE
	B	4094	ADDED WEIGHTS TO SENSOR & CONTROL UNIT & ADDED NOTE ON TANK AIR SPECIFICATION.
	C	4237	REVISED/ECO J.A.H.

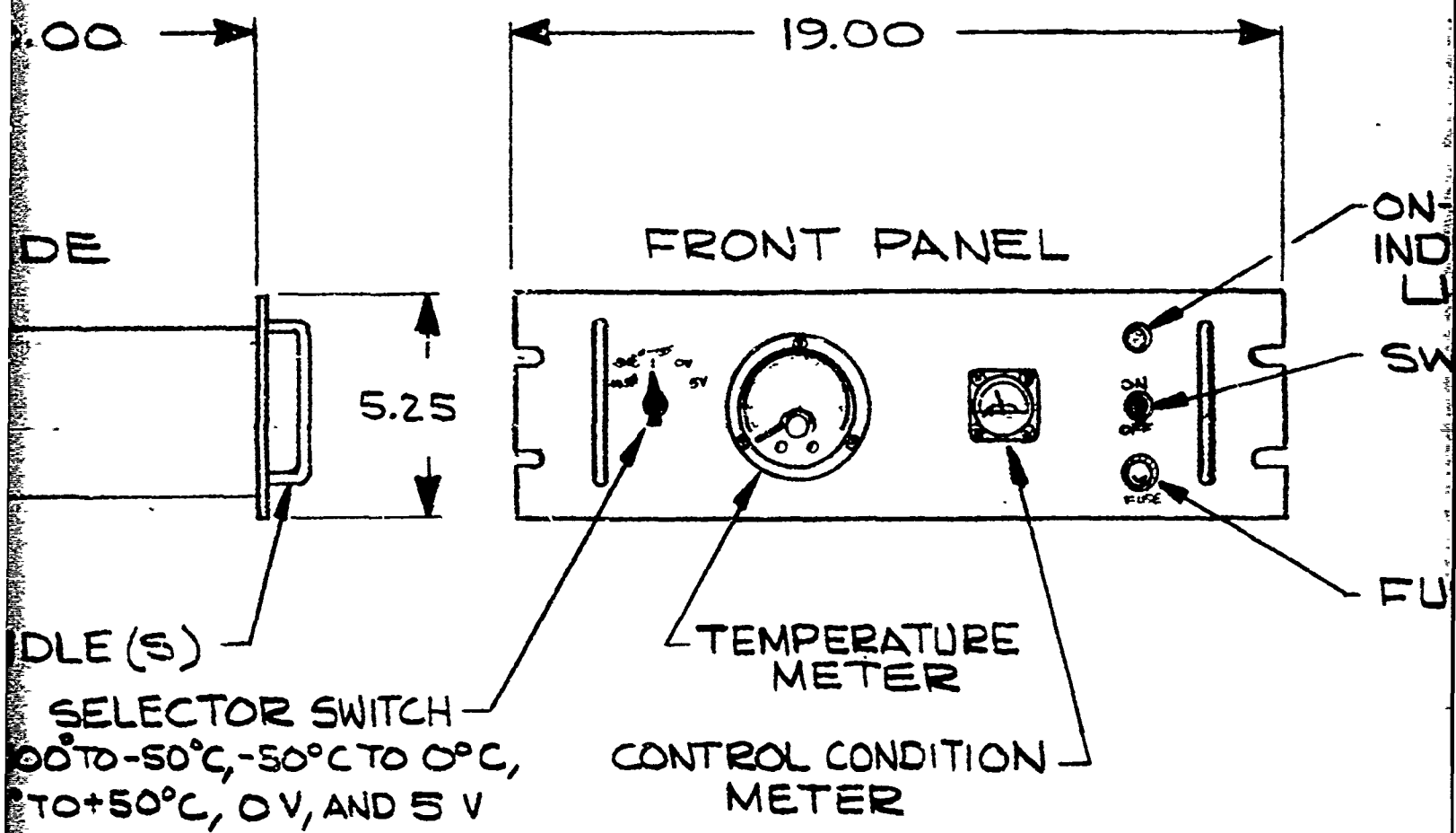

REQUIREMENTS
 VOLTAGE 115V 60C, POWER

CONTROL UNIT
 WEIGHT 25# MAX.

INSTALLATION OPTIONS:

REVISIONS					
ZONE	LTR	E.C.O. NO.	DESCRIPTION	DATE	APPROVAL
	A		INITIAL RELEASE		
	B	4094	ADDED WEIGHTS TO SENSOR & CONTROL UNIT & ADDED NOTE ON TANK AIR SPECIFICATION.	5/21/70	W.P. 5/22/70
	C	4237	REVISED/ECO	J.A.H. 1/2/71	K. 1/2/71

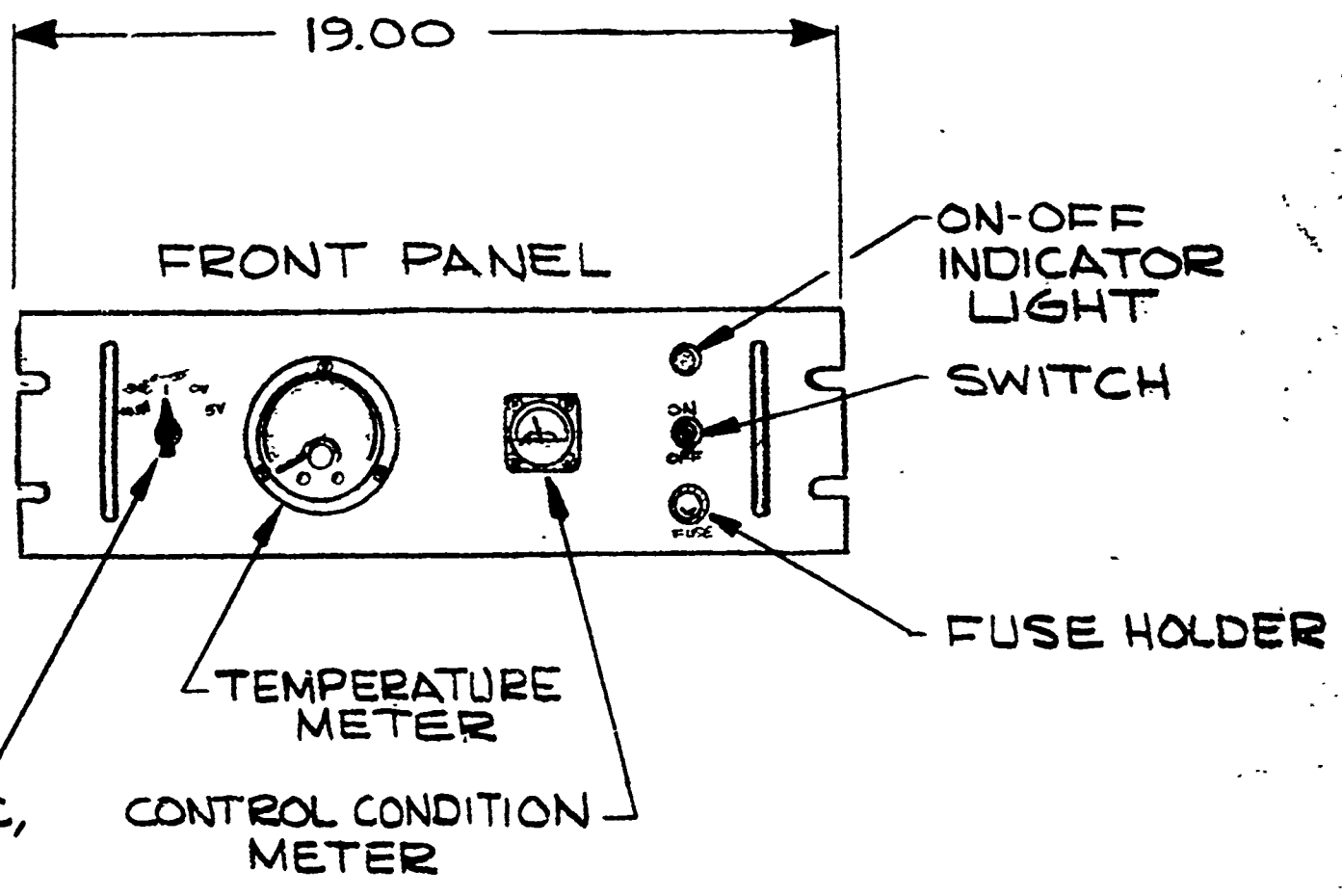

ENTS
POWER

ROL UNIT

AX.

D

C

8.50/8.75 DIA. —
NEEDED IN
CUSTOMERS
PANEL, PLUS
4 HOLES AS
SHOWN IN
SECTION A-A
(CUSTOMERS MTG.)
HOLES

15.50
MAX

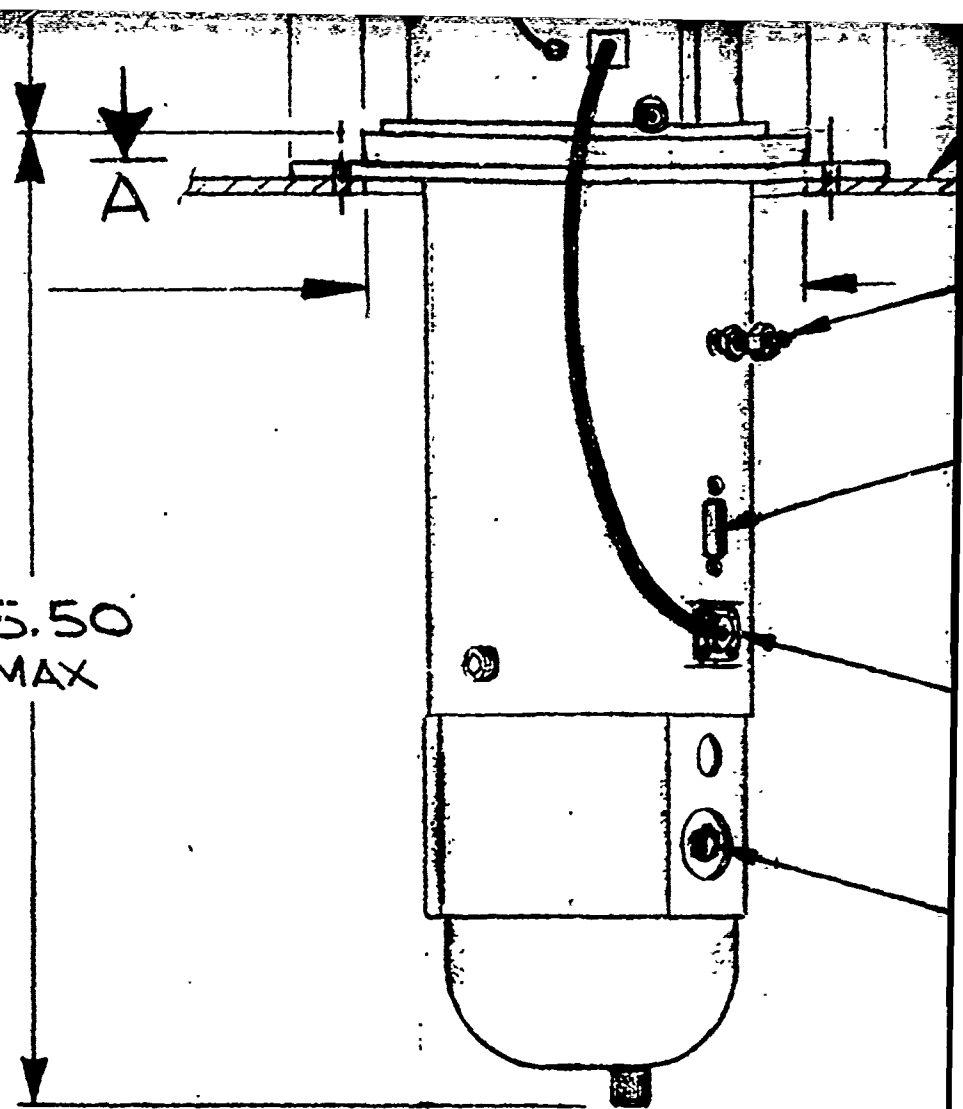

DEW POINT SENSO

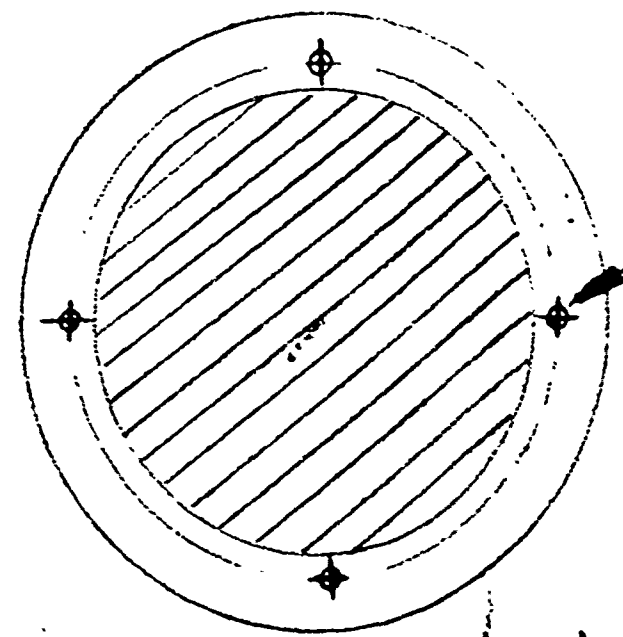

SECTION A-A

F

CUSTOMER'S PANEL



SAMPLE OUTLET
1/4 INCH TUBING

OMEGA CONNECTOR
MP-COCO-MF



BENDIX CONNECTOR
PTO2P-B-4P

AIR SUPPLY FOR STERLING
1/4 INCH TUBE WITH SWAGELOK
FITTING WITH NUT AND
FERRULE IN PLACE

WEIGHT APPROX. 30[#]

4 HOLES
.275 DIA
LOCATED 90°
APART ON
9.25 DIA. B.C
FOR 1/4 HARDWARE

COMPRESSED AIR SUPPLY OPTIONS:

COMPRESSOR (AIR)

CHAMPION NO. 30 CAV 7H
 MOUNTED ON A 15 GAL TANK (ASME)
 RATED FLOW 2.7 SCFM @ 175 PSI

ELECTRIC MOTOR 1 HP, 28V DC, (MARAT)
 LENGTH 36 INCHES
 WIDTH 16 INCHES
 HEIGHT 40 INCHES
 WEIGHT 210 POUNDS

FILTER, WILKERSON NO. 1137-2-FX
 PRESSURE REGULATOR, WILKERSON

TANK AIR (200 CYLINDER SIZE, 9 DIA, 56 H)
 WEIGHT- 146* (1 TANK WITHOUT REGULATOR)
 PRESSURE- 2000 P.S.I.G.

TIME AVAILABLE PER TANK:
 1 HR. 40 MIN. AFTER STARTUP OF SYS
 3 HR. 28 MIN. FOR EACH ADDITIONAL T

REMOVE BURRS, BREAK ALL SHARP EDGES .005 MAX		QTY REQD	PART OR IDENT
UNLESS OTHERWISE SPECIFIED DIMENSIONS ARE IN INCHES.			
TOLERANCES: SURF. ROUGHNESS			
.XX	+		DR <i>[Signature]</i>
.XXX	±		CHK <i>[Signature]</i>
ANGLES	±		
EXCEPT AS NOTED			
MATL			
FINISH			
	196		
NEXT ASSY	USED ON		
APPLICATION			

CTIONS:

7H
TANK (ASME)
175 PSI
28VDC, (MARATHON ELECTRIC)
INCHES
INCHES
INCHES
POUNDS
NO. 1137-2-FX
R, WILKERSON 201-246

SIZE, 9 DIA, 56 HIGH.)
(WITHOUT REGULATOR)

G.
TANK:
STARTUP OF SYSTEM.
WITH ADDITIONAL TANK.

QTY REQD	PART OR IDENT NO.	DESCRIPTION	ITEM NO.
PARTS LIST			
		 CAMBRIDGE SYSTEMS OPERATION NEWTON MASSACHUSETTS	
DR	22 JAN 70		
CHKD	22 JAN 70	INTERFACE DRAWING CRYOGENIC HYGROMETER (STERLING)	
APPD			
	2/15	2/17/70	
	SIZE	CODE IDENT NO.	REV
	D	22905	12897 C
SCALE ~		SHEET 1 OF 1	