

AD 740706



Handwritten notes and signatures in the top right corner.

HIGH ALTITUDE OBSERVATORY
of
Harvard University and University of Colorado

Reproduced from
best available copy.

TECHNICAL REPORT

A New Method of Making Accurate Spectrograph Slits by Photographic Methods

by

Ch'ing-Sung Yü

12 September 1951

ONR Contract N8onr 64801
Project NR 046 708

REC'D
MAY 8 1952
REGISTERED
C 13

Best Available Copy

Produced by
NATIONAL TECHNICAL
INFORMATION SERVICE
1950 O. C. 21

DISTRIBUTION STATEMENT A
Approved for public release;
Distribution Unlimited

HIGH ALTITUDE OBSERVATORY
of
Harvard University and University of Colorado

Technical Report

A New Method of Making Accurate Spectrograph Slits by
Photographic Methods

by

Ch'ing-Sung Yü

12 September 1951

ONR Contract N8onr 64801

Project NRO84-287

ABSTRACT

A new method of making spectrograph slits by photography, suggested by Dr. J. W. Evans, has been developed, in which the properties of a photographic plate (Kodak Type 649) with great resolution and high contrast are utilized to produce microscopically sharp and contrasty edges. Three methods are described; the first by contact printing, the second by shadow printing, and the third by spotlight-exposing followed by contact printing.

The new slit has many advantages over the conventional metal slit. It costs much less to make, and is more uniform in width than any simply-made metal slit. In this investigation, the constancy of width was found to be of the order of + 2 to + 3 microns, and the deviation from the regularity of curve, either straight or circular, is less than 2 microns in a distance of 4 cm.

Spectra of the solar corona have been obtained with a curved photographic slit, and are found to be comparable in quality with those taken with the old metal slit. Furthermore, there are other suggested potentialities for the photographic method to be described further on in this report.

OUTLINE

I.	INTRODUCTION	2
II.	THE TYPE 649-GH PHOTOGRAPHIC PLATE	4
III.	METHODS AND APPARATUS	8
	A. The Contact Print Method	9
	B. The Method of Shadow Printing by Elemer's	10
	C. The Spotlight Method	10
IV.	RESULTS AND DISCUSSION	14
V.	OTHER USES FOR THE METHOD	18
VI.	ACKNOWLEDGEMENT	19
VII.	DISTRIBUTION	20

I. INTRODUCTION.

A slit is an essential part of any spectroscopic instrument. Basically it is a simple, narrow, rectangular aperture, but because of the accurate requirements regarding its true size and shape, a good slit is a delicate mechanism. Optically the slit ranks in importance with lenses, prisms, and gratings.

Because of the simple fact that a spectrum line is nothing but a monochromatic image of the slit, any interpretation of the appearance of the line, with regard to its shape, sharpness, width, and distribution of intensity within the line, must depend on the structure, size, and accuracy of the slit itself. For this reason, an accurate slit should be refined in its regularity of shape and constancy of width. A slit such as this is therefore difficult and expensive to make, especially if a comparatively long one is required.

For accurate work in spectroscopy, a satisfactory slit mechanism should possess the following requirements:

- (1) Strong and sharp jaws with perfect edges, whether straight or curved.
- (2) Edges always lying in the same plane.
- (3) Constancy of width, and parallelism of jaws when slit width is altered.
- (4) Accurate slit-width settings at any opening.
- (5) Symmetrical slit widening with respect to a fixed wavelength in the spectrograph.
- (6) Maximum transmission.

Of course these ideal requirements are not always attained in practice. They are met in most regards by carefully built, conventional metal slits. Such metal slits are made of either brass, stainless steel, or some metal alloy, which, after undergoing optical grinding and polishing (just as in the case of a lens or prism) yield sharp even edges. Thus requirement (1) is practically satisfied. However the edges, being sharp, are extremely delicate and therefore very easily damaged. Quartz jaws giving a finer edge have also been used. But being fragile they are again liable to breakage. Close approach to requirements (2), (3), (4), and (5) have been met more or less by various ingenious mechanical devices. Even then one can never be absolutely sure of the parallelism and exact dimension every time the slit width is changed, unless, of course, it is subjected to checking each time by actual micrometric measurements which is usually impracticable.

Besides metal and quartz slits, other kinds of slits have also

been used. One slit sometimes used is made by etching out from a thin sheet of metal the required opening; another is made by depositing a film of metal (silver or aluminum) on a piece of glass, then engraving or etching on it a slit of the desired width and shape.

All slits with an air gap allow maximum transmission, whereas deposit-on-glass types all suffer some loss of light due to absorption and reflection through the supporting material.

Most of the methods of producing slits, which have hitherto been followed, are laborious and therefore costly. And where long or curved slits are required, the expense of making an accurate slit often becomes prohibitive. Moreover, if a slit of this type is damaged, it is often almost impossible to make another one just like it. Yet sometimes an exact copy is necessary so that results, particularly photometric results, obtained before and after the substitution can be compared safely.

Fortunately, in most fields of spectroscopy not all the requirements mentioned above need to be satisfied. Thus slits of inferior quality are still usable, depending on the tolerance of the problem at hand. For instance, in stellar spectroscopy, the slit openings employed are fairly short and wide, and any slight irregularity in edge and width will not be serious, since it is averaged out in the final analysis with the microphotometer slit which integrates along a section of the spectrograph slit length.

However, in some solar work one wants not a short section but a long uniform straight slit to extend from one limb of the sun to the other, (e.g., in a spectroheliograph); and in other cases, one needs a circular slit of constant width, to scan the corona, the chromosphere, or the prominences along the limb. When we consider all these problems, the whole situation assumes an entirely different aspect. It was these considerations which prompted us to seek another method of producing spectrograph slits which would overcome most, if not all, of the difficulties, including high cost, encountered in the old conventional process.

The ingenious idea came from Dr. J. W. Evans of the High Altitude Observatory. He suggested some time ago that it should be possible to make cheaply an accurate spectrograph slit through photography, by first condensing a small spotlight on a moving photographic plate thereby tracing a dark line in a negative, a contact print of which would produce the required slit. The required accuracy for our purpose was to be within 5 microns in a width of 50 microns along a length of, say, 40 mm.

Although the idea looked attractive, some of us feared at the outset that it might be difficult, if not impossible, to achieve the accuracy required. Other things being equal, the constancy of the width of the spotlight image, which was to be the width of the slit, depended on (1) constancy of the intensity of the spotlight, (2)

constancy of focus, which in turn depended on the flatness and uniform thickness of the photographic plate and the constant level of the moving table on which the plate was mounted, and (3) the uniformity of motion. All these factors have to be kept extremely constant. Any appreciable deviation of any of them would play havoc with the attainment of our goal because of the high accuracy involved. On top of these worries, we feared that we might have another potential enemy to contend with, one which would defeat completely our purpose even before we started, and that was a photographic effect known as spreading or diffusion. This effect therefore would prevent the formation of a sharp edge, by "rounding out the corners", thereby destroying the proper function of the slit. Fortunately, however, all our fears proved to be unfounded as amply attested to by the outcome of this investigation. The secret of the success lies largely in the extremely high contrast and large-resolution photographic plate used, and in the fact that the effect of diffusion is partly offset by another photographic phenomenon, the Eberhard Effect.

II. THE TYPE 649-GH PHOTOGRAPHIC PLATE.

Since our investigation virtually amounts to precise line-copying photographic processes, we naturally looked for the most suitable plate available, which possessed the highest resolution and the greatest contrast. Such a plate, Type 649 with GH sensitization, is manufactured by the Eastman Kodak Company.¹⁾ It is an extremely fine grained orthochromatic emulsion with high resolving power of the order of 1,000 lines per mm. and with great contrast factor, γ , of from 6.5 to 15. As far as we know at present, it is the most contrasty plate available. For comparison with other types of plates, some of the photographic data taken from the paper cited are given in Table I.

TABLE I

Emulsion	Speed (S_A)	Contrast Factor (γ)	Resolving Power (Lines per mm.)
Lantern Slide (Medium)	(12)*	(3)*	100
Kodak Process	0.9	3.2	100
Type II	7.6	2.2	75
Type III	3.0	3.0	95
Type IV	.69	4.1	120
Type 548	(.012)*	6.5 (15)*	500 Approx.
Type 649	(.012)*	6.5 (15)*	1000 Approx.

* Obtained with D8 developer, 2 minutes at 20° C.

1) Eastman Kodak Company, "Photographic Plates for Scientific and Technical Use." (6th Ed.), 1949.

With a high contrast developer, D8, the plate which had been exposed to graduated intensity steps was developed for two minutes under standard conditions. From this we obtained a characteristic curve of the Type 649-GH plate as shown in Figure I b. It will be seen that the straight line portion has a very steep slope ($\gamma = 15$), indicating extremely high contrast. For comparison, the characteristic curve for the lantern slide (medium) plate, obtained under similar conditions, is also plotted in Figure I a. It is clear that the Type 649 plate is a very slow emulsion, about 1,000 times as slow as the lantern slide plate.

The fact that the diffusion effect in our case plays a very insignificant role, as mentioned above, can be easily understood. Consider b a (Figure 2) to be the illumination (I) at the edge of a uniformly illuminated area, A , to be impressed on the photographic plate. Let the illumination at b (I_b) be unity. Due to diffusion the straight line ba , which otherwise should produce a sharp edge on the plate, has assumed, from experimental results, the logarithmic form ²⁾ bf , expressed by

$$x = a + \Gamma \log I \quad (1)$$

where x is the distance in microns into the shadow, that is, in the direction perpendicular to the edge of the image, and a and Γ are constants. The theoretical aspect (a turbidity phenomenon) of this and allied formulae has been extensively discussed by Ross ³⁾. To go into it here, even briefly, would take us too far afield. Now suppose the photographic density caused by b lies on point b' in Figure 1b, then on a point e on the intensity curve, where the intensity has fallen to, say, one-half the value at b , corresponding to a decrease of $\log I$ (or $\log E$, since the exposure time is constant) by 0.3, the density drops abruptly due to high gamma, from 3.5 (b') to below 0.5 (e') in Figure 1b. The latter hardly impresses itself on the plate. All values of I smaller than one-half would not appear on the plate at all. The distance from the theoretical edge, b , to the image edge, near e , is, for our special plate and quality of illumination, only of the order of a few microns. From actual measurements of graded images, the constants, a and Γ in equation (1) for the Type 649-GH plate, are found to be as follows: $a = 2.5$, and $\Gamma = 16.6$. The latter is usually known as astrogamma.

The above discussion shows the intimate relationship between the value of γ and the sharpness of image. The greater the γ , the sharper the image, a fact already pointed out by Goldberg. ⁴⁾ This relationship can also be derived analytically as follows.

The sharpness of an image (S) is defined as the differential of

-
- 2) Mees; "Theory of the Photographic Process", p. 887, 1942.
 - 3) Ross; "The Physics of the Developed Photographic Image", pp. 93-107.
 - 4) Ross; loc cit. p. 116.

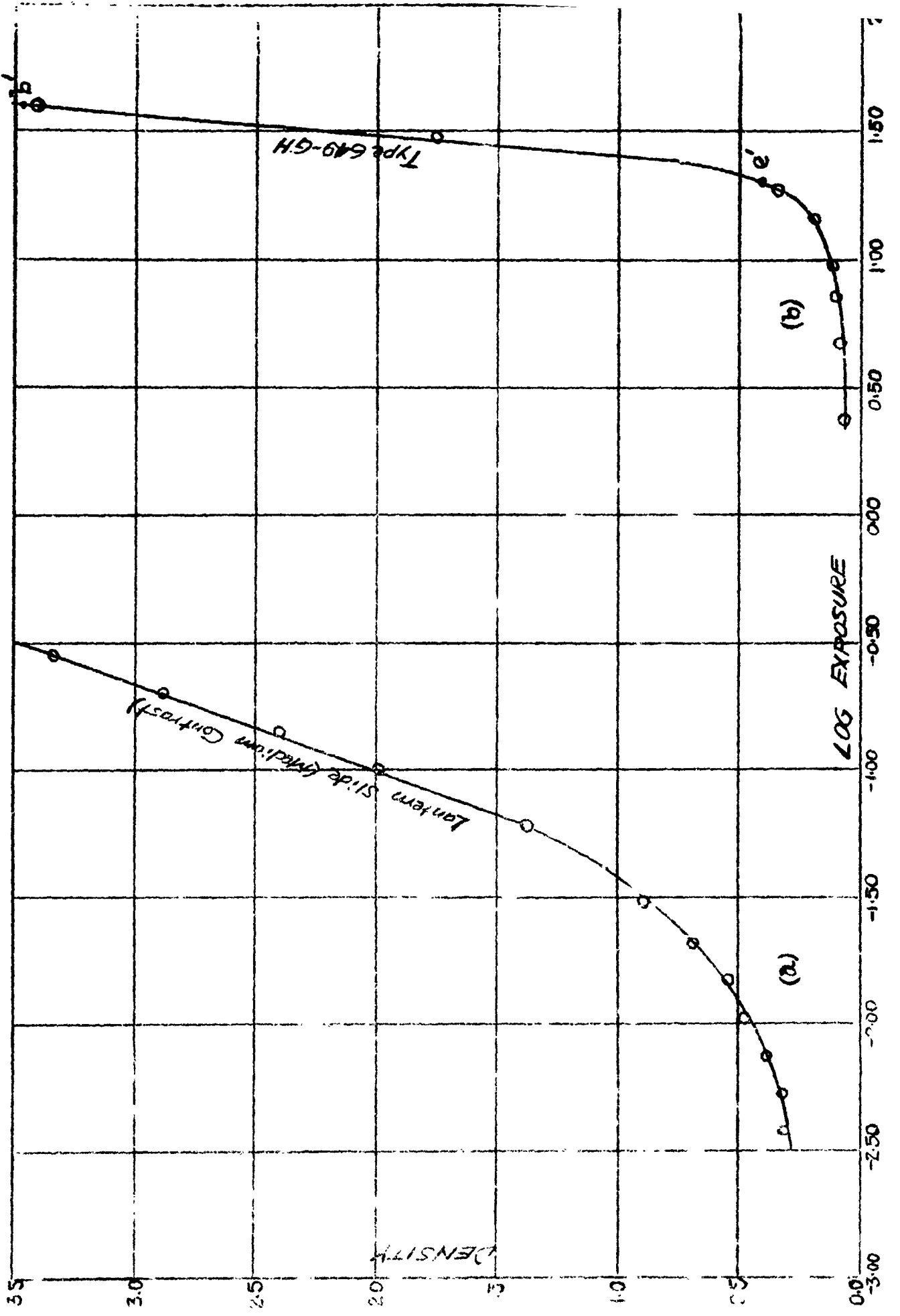
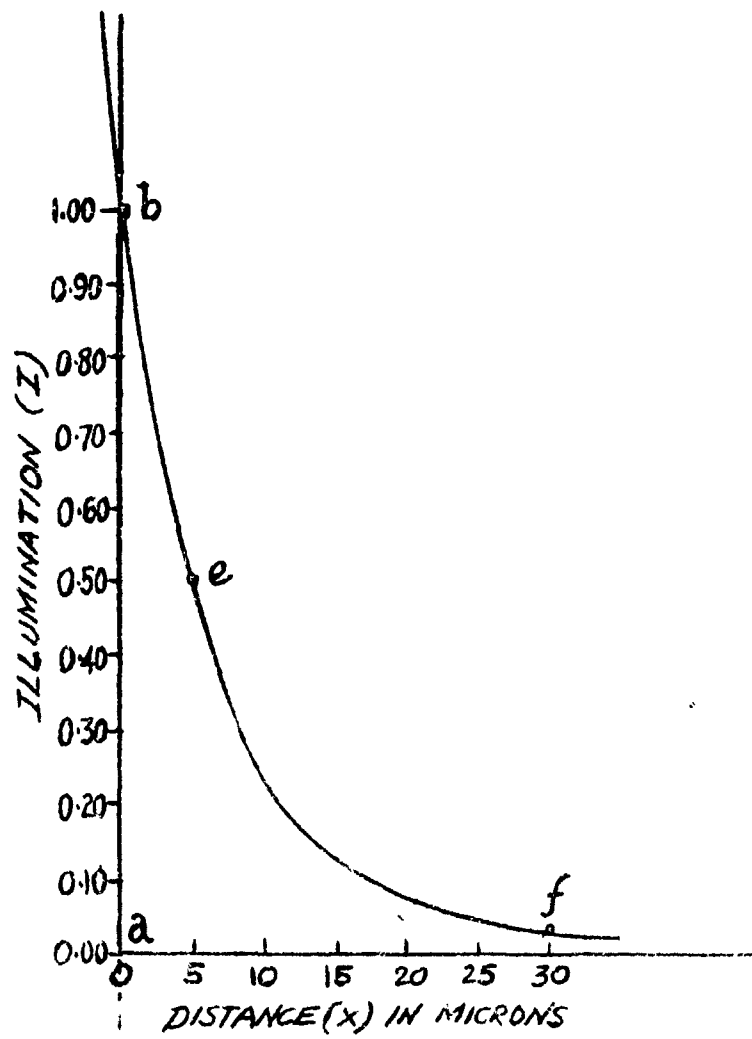

FIGURE 1



A

FIGURE 2

density (D) with respect to the distance (x) into the shadow, or mathematically,

$$S = \frac{d D}{d x} \quad (2)$$

Differentiating equation (1), we get

$$dx = I^{\gamma} d(\log I) \quad (3)$$

Since, for the straight portion of the characteristic curve,

$$\gamma = \frac{d D}{d (\log I)} \quad (4)$$

Equation (2) becomes, after substituting (3) and (4),

$$S = \frac{\gamma}{I} \quad (5)$$

which gives a direct relation between the value of γ and the sharpness of image. The numerical value of sharpness for Type 649 plate is 0.910, against 0.140 which is that found for the lantern slide plate.

From what we have seen above, it is no surprise that in spite of the much-dreaded diffusion effect to round off the corners of our slit edge, the latter appears sharp and contrasty. It is clear, too, that the sharpness of the edge, within certain limits, is independent of exposure.⁵⁾ As long as the plate is sufficiently overexposed, the edge will always remain sharp. This holds true also when diffraction effect is present during shadow or contact printing, or even when the impinging spotlight is not purely achromatic or if it should happen to be slightly out of focus. All these secondary effects serve only to modify the size of the image without affecting its sharpness. As a matter of fact, in practice this principle is utilized in the differential adjustment of the width of the photographic slit by varying the exposure time to arrive at the exact figure desired.

III. METHODS AND APPARATUS.

Before discussing in detail the spotlight method (C) of making photographic slits, suggested by Evans, I wish to describe briefly two simpler and more direct methods (A and B) that I have considered. These require a less elaborate instrumental setup, and are much easier to perform. But it must be admitted at the outset that they are not as accurate. However, the methods are presented here in the belief that they may be useful in problems where great accuracy is not required.

5) *ibid.*, loc. cit. p. 126, (Fig. 51), p. 134.

A. The Contact Print Method.

The simplest method is by contact printing. A piece of thin wire is used, the diameter of which conforms to the width of slit desired, and which is completely free of dust particles. The photographic slit is made by placing the wire in the shape (straight or curved) required on a clear plate, clamping on the photographic plate, and printing it with a collimated light very much as you would print a snapshot negative. However, it is not quite as easy as this.

For one thing, ordinarily available wires of even fairly short lengths, do not come in uniform cross-section. I tried a 0.001" bare tungsten wire, and a 0.002" enamelled resistance wire and found that the variation of diameter in a stretch of two inches, amounted to as much as 20%. This no doubt is due partly to the inequality of the wires, and partly to the unevenness of the enamel covering. However, a short section of photographic slit thus made usually has a fairly uniform width.

The chief problem is how to keep the wire straight or to make it conform to any curve desired, whether circular or otherwise. To keep it straight is comparatively easy. All that is necessary is to stretch it tautly on top of a clear plate. The tighter the stretch the straighter the wire. However, it is easy to exceed the limit at which the thin wire will break.

It is more difficult to make the wire assume a curved shape and requires some special techniques to accomplish. In my experiment I made a flat metal template about 1/4 inch thick with the edge machined to the curve desired, in my case a circle about one inch in diameter. (As used in the High Altitude Observatory coronagraphs, a circular slit with an arc of 60° is sufficient). I placed the template on top of a clear glass, and wound the wire around 3/4 of the circumference close to the plate, and fastened the straight ends (drawn tight) on to the plate with scotch tape. Unfortunately, even when the template is carefully lifted, the wire will not remain in position. After a number of unsuccessful trials to make the wire adhere to the plate in the desired position, I accidentally discovered that by rubbing the glass with a piece of tissue paper (more conveniently from the under side when the template and the wire are in place) I could impart a slight static charge to the glass, such that when the template is lifted, the wire, being now attracted to the glass, stays undisturbed. I then made my contact print. Care, of course, must be taken not to side-swipe the wire during loading of the plate. Several circular slits of 0.002" have been made this way. However, the accuracy of the slits is limited again by the accuracy of the wire itself and the accuracy of the template and the placement of the wire.

The smallest width of slits which can be made this way is

limited only by the size of wire available. However, for even finer slits, fine human hairs can presumably be used also.

B. The Method of Shadow Printing by Elements.

For accurate spectrographic work, the chief objection to method A is that the diameter of wires is not tolerably uniform along its length, thereby giving rise to unevenness of the slit width. The method, however, can be improved with corresponding increase of accuracy, though more elaborate equipment is necessary.

The improved method consists of selecting a short uniform section of wire about a few mm long, and stretching it across a window slit opening of 1 mm. or less. This 1 mm of wire across the opening constitutes the elementary unit. The photographic plate is placed on a carriage platform (e.g., a Gaertner measuring microscope) which can be moved linearly and uniformly by a synchronous motor with proper gear attachments. With the slit mounted rigidly to the frame of the machine, about 1/2 mm. directly over the plate, wire side downward, and a darkroom enlarger placed above the window providing a collimated uniform illumination, and with the plate moving, a shadow of the element of the wire is continuously traced on the plate. This produces a photographic slit of uniform width. Any small irregularity in the short section of the wire selected is smoothed out in the process of tracing. Of course, the wire must be set exactly parallel to the direction of motion. Otherwise the edges will not be sharp due to unequal exposures. The width of the window opening is determined by the intensity of the printing light and the speed of motion, to ensure sufficient exposure. In general, the smaller the opening the better.

In making a circular slit, a rotating table is used instead of the linear carriage. Here the window opening is in the form of a sector (although for narrow openings a rectangular one will serve just as well) and the wire must be set tangent to the circular motion. The element of wire used for circular tracing can be made straight instead of conforming to the curvature, since the angle subtended by the wire is so small that a straight or curved section makes no appreciable difference, and it is much easier to set a wire straight than to make it conform to any curve. The distance of the wire from the center of motion determines the diameter of the circular slit. I have made both kinds of slits with this method and have found them both workable.

C. The Spotlight Method.

This method, as already stated, is the most accurate, and at the same time a little more elaborate. It requires the use of a good microscope, and accurate moving mechanisms. I describe here the procedure for the spotlight method as I worked it out.

The source of illumination in our instrumental setup was a G.E. 6-volt Ribbon Lamp (1), (see Figure 3), which burns with constant intensity and uniform brightness across its area. Three steps of intensity are available through the resistance (2). This even patch of light was enlarged and focused on the rectangular window (6) by the lens (3). In my setup (4) is an iris diaphragm which I used to further regulate the light. The window (about 1 mm x 2 mm) was flanked on the lamp side with a piece of opal glass (7) to diffuse the illumination. For circular slits, the light from the window was deflected downward (Figure 3a) by a front surfaced mirror (12). With an ordinary microscope (with 10x objective and the eyepiece removed) working backwards, I condensed the light from the window and focused it on the photographic plate (15). The reduction ratio was about 36 to 1. The photographic plate rested on a flat round table (16) whose axis was mounted with two self-aligning SKF ball bearings. The table was rotated slowly by a 1/2 RPM synchronous motor (18) through the non-slip belt (17). The reduction ratio here was 2 1/4 to 1. Thus when the table was rotated during exposure a circular line was produced. This table and mountings, made entirely of steel to ensure stability, was constructed by Mr. K. Kellogg at the High Altitude Observatory machine shop according to my design. It was tested for accuracy before usage and found satisfactory.

In order to get good focus for exposing, a viewing microscope (22) was used. This is shown only in Figure 3b. In Figure 3a it is mounted in the plane perpendicular to the paper.

Other things being equal, the width of the photographic slit depends primarily on the dimension of that side of the rectangular window perpendicular to the direction of motion. The dimension of the other side, together with the intensity of light and the speed of motion, determines the exposure needed to reach sufficient photographic density. The edges of window (6) need not be perfectly sharp to obtain an even image edge at the photographic plate. For one thing, its size has been reduced by a factor of 36, and more specifically, any small irregularity is smoothed out in the process of tracing. It is important, however, that the edges should be accurately orientated to the direction of motion.

After I obtained the master negative, it was a simple matter to produce the slit itself by contact printing. Photographic slits produced this way have been compared with good metal slits under a high-powered microscope. As far as the eye can judge, the two slits are comparable with regard to sharpness, evenness of edge, and uniformity of transmission.

To obtain different diameters of the circular slit, I moved the table sideways by means of the set screw (19). A number of circular slits of the order of 50 microns wide and of various diameters (about 30 mm) have thus been obtained. Different sized slits are necessary in order to accommodate the change of the

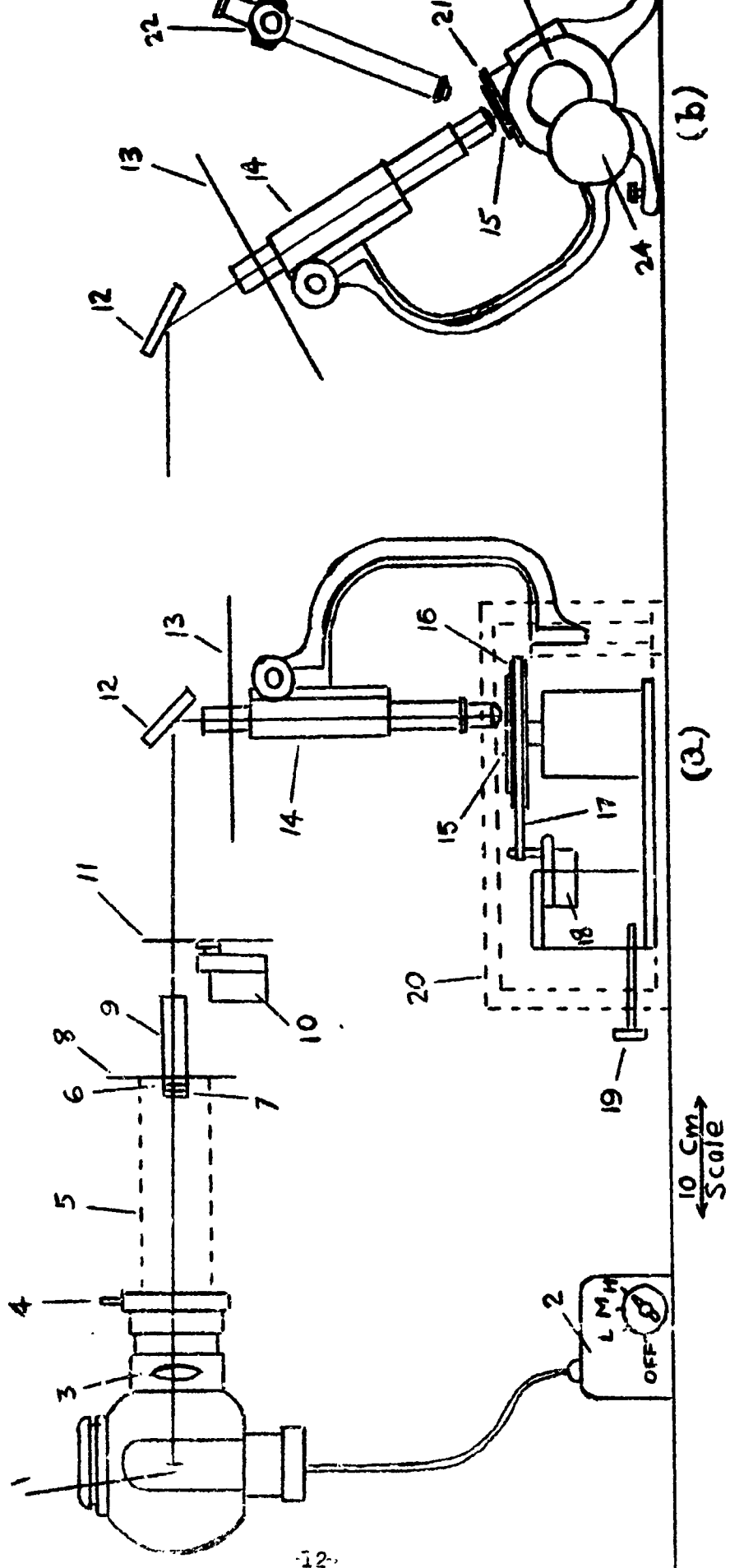

FIGURE 3

Notes on Figure 3

1. G.E. 6-volt Ribbon lamp.
2. Transformer and resistances for three steps of lamp intensity.
3. Enlarging lens, which focuses the image of the incandescent ribbon on the window (6).
4. Iris diaphragm, to further regulate intensity of illumination.
5. Cardboard tube, to shade off stray light.
6. Rectangular window, (about 1 mm x 2 mm).
7. Opal diffusing glass.
8. Cardboard diaphragm.
9. Metal tube, for mounting (6) and (7) and keeping off stray light.
10. Synchronous motor.
11. Rotating shutter, (used only for intermittent exposures in making gratings).
12. Front surfaced aluminized mirror, to deflect beam of light.
13. Cardboard diaphragm.
14. Exposing microscope (10x objective) minus eyepiece.
15. Photographic plate.
16. Rotating table.
17. Non-slip belt, (reduction ratio 24:1).
18. Synchronous motor (1/2 RPM).
19. Set screw.
20. Wooden box.
21. Gaertner measuring microscope carriage.
22. Viewing microscope (3x objective).
23. Reduction gear (ratio 2.4:1).
24. Synchronous motor (4 RPM).

solar image for different seasons. These slits have been tried at the Sacramento Peak and Climax stations of the High Altitude Observatory as described later.

To produce straight slits, I substituted the rectilinear carriage (21) (Figure 3b) of the Gaertner machine for the rotating table. The gear train (23) is run by a 4 RPM synchronous motor (24).

The whole operation to expose a circular slit of 200° arc, or a straight slit of 4 cm. length, required about one hour. One great advantage of this method, besides its higher accuracy, is the fact that, unlike methods A and B, where only one plate is made at a time, as soon as a negative is obtained to serve as a master copy, any number of exact duplicates can readily be made by simple contact printing.

In the spotlight method the smallest width of slit which can be obtained is limited only by the resolution of the photographic plate, the finite width of the illuminated window, and the photographic effect of diffusion. With the Type 649-GH plate used here, it is possible to obtain sharp lines as narrow as three microns.

IV. RESULTS AND DISCUSSION

By the above methods I obtained photographic slits with a sharp, even edge, and good and uniform transmission. The next step in my work was to determine how accurate they are. The accuracy of a spectrograph slit resolves itself into two principal parts: (a) constancy of width along its length, and (b) trueness of shape, whether straight or curved.

In our process, the width of the photographic slit is dependent on a number of factors: (1) the intensity of the source of light, (2) focus, (3) even thickness of the photographic plate, (4) flatness of the table mount, (5) uniformity of motion, (6) vibration and possibly other factors. The constancy of all these factors was uncertain at the start, as was the necessary guiding accuracy of the moving carriage, upon which the trueness of the path depends. However, satisfactory slits were made in spite of these uncertainties.

For the purpose of testing the accuracy of slits produced by this method, I mounted a straight slit 40 mm. long in the Gaertner machine. I then measured the width of the slit for points at 1 mm. intervals with a travelling wire micrometer microscope. The results are summarized in Figure 4.

The upper curve of Figure 4a represents the measures of the top edge of the slit, whereas the lower curve represents those of the bottom edge. The scales for the abscissa and the ordinates are different.

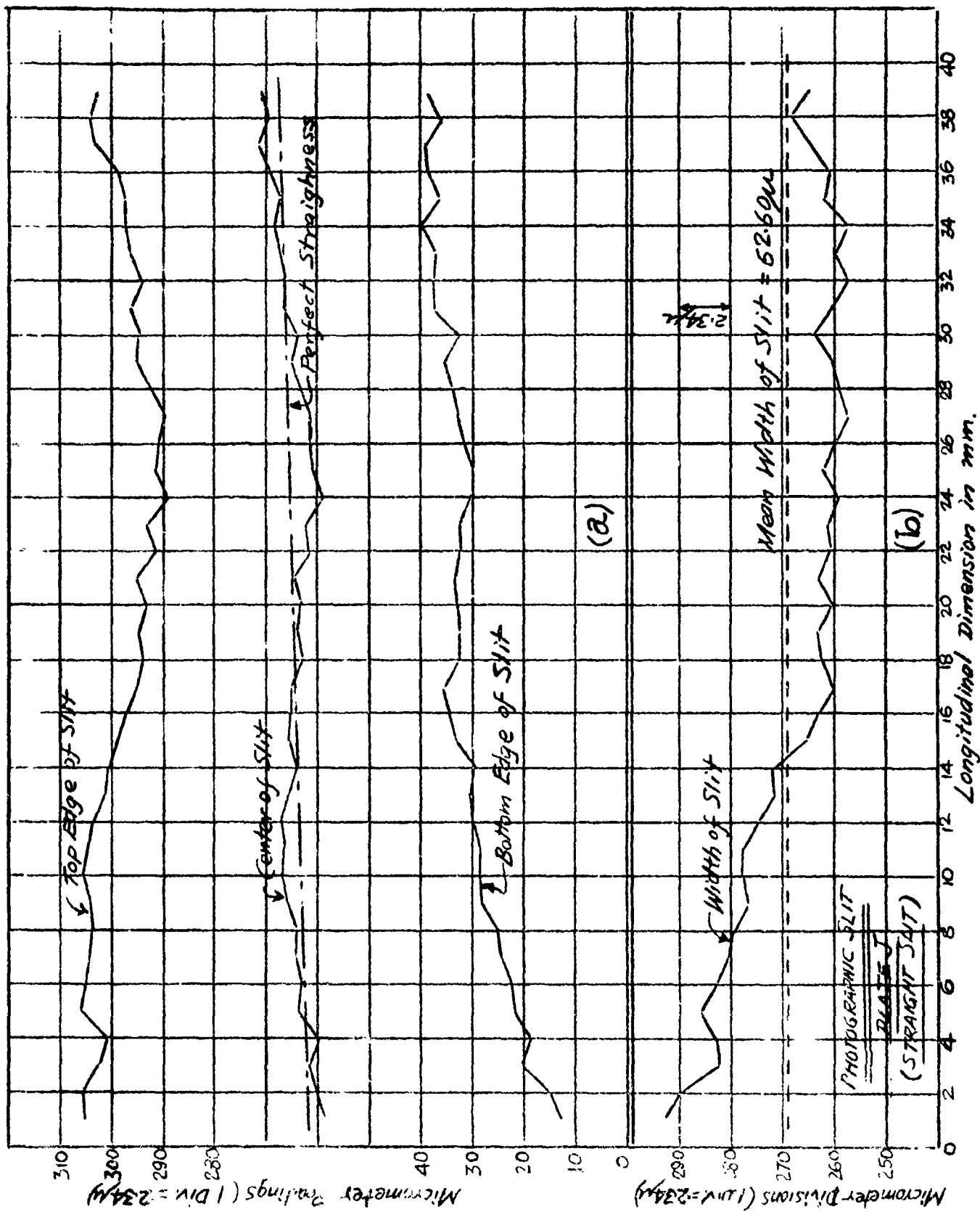

FIGURE 4

Also, in order to conserve space, I have made the two ordinate scales overlap. One division of the ordinate represent 2.34 microns as indicated by the arrow. By subtracting the lower curve from the upper curve, we get the variation of the slit width as shown in Figure 4b. The variation from the mean value is less than 3 microns, which is smaller than our original goal (5 microns). By taking the mean of the upper and lower curves (Figure 4a) we obtained the middle curve which represents the center of the slit. The line through the middle curve shows perfect straightness. The deviation of the actual slit from true straightness in a length of 4 cm. is less than 2 microns. The slight slope indicated by the straight line is due, of course, to the orientation of the plate in the carriage.

Similar measurements with the width of the circular slits at intervals along the arc have been made also, and they indicate the same order of accuracy. Without a circular measuring machine it was not possible to investigate the accuracy of the circularity of the slit. However, from previous tests of the rotating platform the circle appears to the eye to be perfectly true. At any rate, the requirement for circularity of the curved slit as used in coronagraphs is not nearly as rigid as that for the constancy of width. A slit which shows no deviations from circularity visible to the naked eye is probably satisfactory for these purposes.

The circular photographic slits have been tried at the Sacramento Peak and Climax stations coronagraph spectrographs. The spectra of the corona taken at Sacramento Peak by Mr. H. E. Ramsey, are reproduced in Figure 5. In Figure 5, (a) is a spectrum obtained with the conventional metal slit, whereas (b) is the same spectrum taken with the photographic slit. The slit widths in both cases are identical. A slight increase of exposure would be needed with the photographic slit to compensate for the small absorption of light through the clear photographic emulsion. However, the corona lines as well as other solar lines from scattered photospheric sunlight, appear practically as sharp and intense in the new spectrum as in the former. In addition, in the latter, there are definitely less dust "lines", since it is much easier to clean the photographic slit. Many horizontal lines are still present on both spectra, perhaps due not to dust on the slits, but dust on the edges of the occulting disk, or on the field lens.

Here I wish to mention one curious phenomenon encountered in the progress of this investigation. It is a well known fact that when a slit is viewed close to the eye in front of a point source of light, a diffraction band appears with a regular interference pattern characterized by alternate bright and dark intervals. A photographic slit, while still wet from the bath, similarly viewed, exhibits the same pattern. However, I was much surprised to find the dark bands disappear altogether when the plate is dry, although the bright band remained. If the plate is put in the water again, the original pattern returns. The phenomenon seems to be a surface film effect, but I have not been

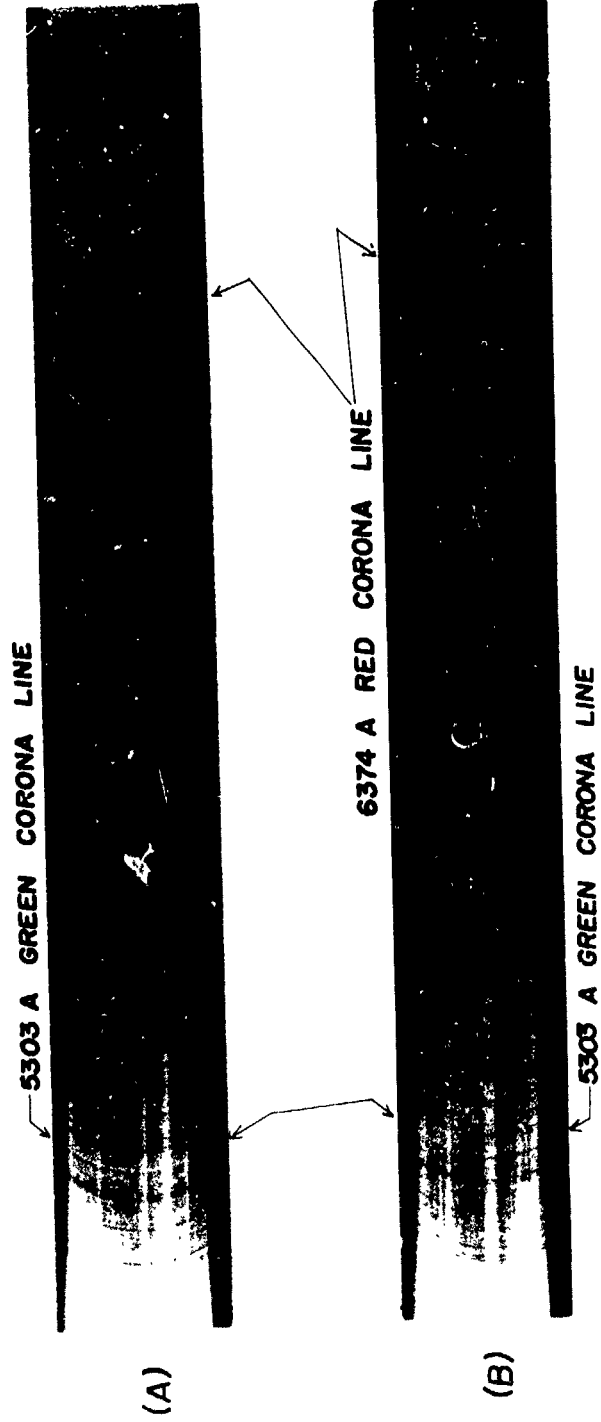

(A) Corona Spectrum Taken With A Circular Metal Slit.
 (B) Same Spectrum Taken With A Circular Photographic Slit.

FIGURE 5.

able to find an explanation for it.

Our spectra with the photographic slit shows conclusively the successful function of the new slit. I shall now summarize some of the outstanding advantages of the photographic slit:

- (1) Easy to make, and less expensive.
- (2) Easy to duplicate and replace, insure identity.
- (3) Easy to mount, especially where limitation of space is of importance, as in a Schmidt camera.
- (4) Easy to clean, less dust lines.
- (5) More accurate in constancy of width and regularity of shape.
- (6) One integral part, so that slit edges always lie in the same plane.
- (7) No lateral motion involved, to vary width of slit. Slits of different known widths could be readily substituted.

Of course there are some disadvantages to the photographic slit. For instance, it is easy to break, but this is offset by the fact that it is easy to replace. One real disadvantage in comparison with the metal slit is the unavoidably smaller transmission power, as a result of the absorption and reflection losses through the emulsion and the glass plate. The clear plate has a density of about 0.05, thereby suffering a loss of light of 10%. However, in some solar work, where light is plentiful, this is not a serious matter. In coronal spectrum photography it is a serious matter if exposures are lengthened appreciably. This difficulty may be alleviated to some extent if we use aluminum-on-glass etched slits, made from photographic masters produced by the techniques outlined in this report.

V. OTHER USES FOR THE METHOD.

The method of producing photographic slits as outlined here, is capable of extension to other lines of work. For example: making (1) coarse gratings, (2) tiny occulting disks in special photographic cameras, where making and mounting such a small disk is a problem, (3) micrometric recticles and scales (4) accurate photo-engravings; or in fact any work where the production of fine lines or of sharp and opaque edges are involved.

VI. ACKNOWLEDGEMENT

It is a pleasure to acknowledge my gratitude to Dr. J. W. Evans, who originated the idea of making photographic slits and who offered numerous valuable advices during this investigation. My thanks also to Dr. W. O. Roberts, Superintendent of the High Altitude Observatory, for assigning this interesting problem to me and giving me much encouragement. My appreciation goes also to Mr. H. E. Ramsey for obtaining the corona spectra for me at Sacramento Peak. I am indebted to Mrs. I. Witte, too, for the reproduction of the spectra shown in this paper.

Ching-Sung Yü
Ch'ing-Sung Yü

High Altitude Observatory
Boulder, Colorado

Approved for Submission as
Technical Report

Walter Orr Roberts
Walter Orr Roberts

8 October 1951