

BRL MR 2159

# BRL

AD

MEMORANDUM REPORT NO. 2159

## VACUUM EQUIPMENT USED IN THE BALLISTIC RESEARCH LABORATORIES' SUPERSONIC WIND TUNNELS

by

Howard A. Ricci

March 1972

Reproduced by  
NATIONAL TECHNICAL  
INFORMATION SERVICE  
Springfield, Va. 22151

Approved for public release; distribution unlimited.

DDC  
RECORDED  
APR 26 1972  
REGULATED  
C

U.S. ARMY ABERDEEN RESEARCH AND DEVELOPMENT CENTER  
BALLISTIC RESEARCH LABORATORIES  
ABERDEEN PROVING GROUND, MARYLAND

AD 740741

23

Destroy this report when it is no longer needed.  
Do not return it to the originator.

Secondary distribution of this report by originating or  
sponsoring activity is prohibited.

Additional copies of this report may be purchased from  
the U.S. Department of Commerce, National Technical  
Information Service, Springfield, Virginia 22151

ACCESSION BY	
DEFENSE	WHITE SECTION <input checked="" type="checkbox"/>
DAS	BUFF SECTION <input type="checkbox"/>
INVESTIGATIONS	<input type="checkbox"/>
ADMINISTRATION	
BY	
ASSISTANT SECRETARY FOR SECURITY SERVICES	
DATE	AT'L. NO. or SPECIAL
A	

The findings in this report are not to be construed as  
an official Department of the Army position, unless  
so designated by other authorized documents.

*The use of trade names or manufacturers' names in this report  
does not constitute endorsement of any commercial product.*

BALLISTIC RESEARCH LABORATORIES

MEMORANDUM REPORT NO. 2159

MARCH 1972

VACUUM EQUIPMENT USED IN THE BALLISTIC RESEARCH LABORATORIES'  
SUPERSONIC WIND TUNNELS

Howard A. Ricci

Exterior Ballistics Laboratory

Approved for public release; distribution unlimited.

RDT&E Project No. 1T262301A201

ABERDEEN PROVING GROUND, MARYLAND

UNCLASSIFIED  
Security Classification

DOCUMENT CONTROL DATA - R & D

(Security classification of title, body of abstract and indexing annotation must be entered when the overall report is classified)

1. ORIGINATING ACTIVITY (Corporate author) U.S. Army Aberdeen Research & Development Center Ballistic Research Laboratories Aberdeen Proving Ground, Maryland 21005		2a. REPORT SECURITY CLASSIFICATION Unclassified	
		2b. GROUP	
3. REPORT TITLE VACUUM EQUIPMENT USED IN THE BALLISTIC RESEARCH LABORATORIES' SUPERSONIC WIND TUNNELS			
4. DESCRIPTIVE NOTES (Type of report and inclusive dates)			
5. AUTHOR(S) (First name, middle initial, last name) Howard A. Ricci			
6. REPORT DATE March 1972		7a. TOTAL NO. OF PAGES 33	7b. NO. OF FIGS 6
8a. CONTRACT OR GRANT NO.		8b. ORIGINATOR'S REPORT NUMBER(S) BRL Memorandum Report No.2159	
9. PROJECT NO. RDT&E Project No. 1T262301A201		9b. OTHER REPORT NO(S) (Any other numbers that may be assigned this report)	
10. DISTRIBUTION STATEMENT Approved for public release; distribution unlimited.			
11. SUPPLEMENTARY NOTES		12. SPONSORING MILITARY ACTIVITY U.S. Army Materiel Command Washington, D. C.	
13. ABSTRACT A pressure measuring facility is described with emphasis on adequacy of primary standard type devices for referencing all pressures of interest in wind tunnel testing. These devices are described and include commercially available and in-house fabricated systems. The lowest range standard is patterned on a similar National Bureau of Standards device.			

DD FORM 1473 1 NOV 65

REPLACES DD FORM 1473, 1 JAN 64, WHICH IS OBSOLETE FOR ARMY USE.

UNCLASSIFIED  
Security Classification

14. KEY WORDS	LINK A		LINK B		LINK C	
	ROLE	WT	ROLE	WT	ROLE	WT
Pressure Vacuum Wind Tunnel						

BALLISTIC RESEARCH LABORATORIES

MEMORANDUM REPORT NO. 2159

HARicci/lca  
Aberdeen Proving Ground, Md.  
March 1972

VACUUM EQUIPMENT USED IN THE BALLISTIC RESEARCH LABORATORIES'  
SUPERSONIC WIND TUNNELS

ABSTRACT

A pressure measuring facility is described with emphasis on adequacy of primary standard type devices for referencing all pressures of interest in wind tunnel testing. These devices are described and include commercially available and in-house fabricated systems. The lowest range standard is patterned on a similar National Bureau of Standards device.

PRECEDING PAGE BLANK

TABLE OF CONTENTS

	Page
ABSTRACT . . . . .	3
LIST OF ILLUSTRATIONS . . . . .	7
I. INTRODUCTION . . . . .	9
II. PRESSURE CALIBRATION SYSTEMS . . . . .	9
III. REFERENCE VACUUM SYSTEMS . . . . .	13
REFERENCES . . . . .	30
DISTRIBUTION LIST . . . . .	31

PRECEDING PAGE BLANK

LIST OF ILLUSTRATIONS

Figure		Page
1.	Oil Dead Weight Tester . . . . .	16
2.	Air Dead Weight Tester . . . . .	17
3.	Three Stage-Pressurized Manometer Range 600 cm Hg Abs . . .	18
4.	Mercury Servomanometer Range 80 cm Hg Abs . . . . .	19
5.	Oil Servomanometer Range 1 psia . . . . .	20
6.	Point Contact Manometer Range 8 mm Hg Abs . . . . .	21
7.	Bell Jar Pump Station . . . . .	22
8.	Schematic Flow Diagram Pump Station . . . . .	23
9.	Sputter-Ion Pump . . . . .	24
10.	Molecular Sieve Trap . . . . .	25
11.	Ion Pump -- Internal Construction . . . . .	26
12.	Ion Pump Speed Versus Pressure . . . . .	27
13.	High and Low Range Nude Ion Gages . . . . .	28
14.	Ion Pump Current Versus Pressure . . . . .	29

PRECEDING PAGE BLANK

## I. INTRODUCTION

The Ballistic Research Laboratories' Supersonic and Hypersonic Wind Tunnel Facility has the potential for continuous testing of aerodynamic parameters over a Mach number range of  $M = 1.5$  to  $M = 9.2$  (see reference 1\*). The engineering data generated by variable density tunnels requires that redundant pressure measurements be made accurately. To systematically monitor these variables, pressure scanning techniques have been developed (reference 2) for the effective use of strain gage and reluctance type transducers. The pressure span of interest varies from several thousand psia to  $10^{-3}$  Torr. The bulk of the measurements, however, is in a difficult pressure range between one micron and 10 cm Hg absolute; a region where readily available primary pressure standards are not accurate.

The wind tunnel maintains an overall 1% aerodynamic data accuracy. Stringent specifications are, therefore, placed on all sensing devices to have a reliability of better than  $\pm 0.25\%$  full scale. The extensive quantity of data generated during a wind tunnel program makes it mandatory to calibrate rapidly and frequently. This laboratory has endeavored to develop techniques and instrumentation to effectively calibrate the many pressure devices it uses.

The primary objectives of this report are to (1) acquaint the testing agency with the available instrumentation for calibration pressure transducers, (2) the progress in solving the low pressure measurement problems, and (3) to describe several low pressure standards in use by this laboratory.

## II. PRESSURE CALIBRATION SYSTEMS

The pressure calibration systems are several in nature and vary widely in scope. In Table I absolute pressures of one micron Hg to 2,200 psi are accurately measured in overlapping ranges by the use of piston type dead weight gages and manometers. Below one micron Hg hot

\* References are listed on page 30.

filament ion gages and cold cathode type are utilized to monitor relative values of reference vacuum. These types are sensitive and should have frequent comparison with standards.

Table I. Approximate Pumping Speed for Various Gases Relative to Air

Hydrogen	270%
Light Hydrocarbons	90-160%
Nitrogen	100%
Carbon Dioxide	100%
Water Vapor	100%
Oxygen	57%
Helium	10%

The dead weight piston gage is one of the few instruments that can be used to measure pressure in terms of fundamental units of force and area. This laboratory uses two types, (1) the Aminco Dead Weight Tester, model 47-2060 (Figure 1), range atmospheric to 3,000 psig, modified with an air oil separator and electrical reference readout, and (2) a triple-range dead weight air piston gage, manufacturer is Consolidated Electrodynamics Corporation (CEC), type 6-201 (Figure 2). The former unit is used to measure pressures above 200 psig to accuracies of 0.1% of reading; the latter is used for absolute or gage pressures through range of 0.3 psia to 500 psia, with accuracies varying 0.015% to 50 psia and 0.25% of reading above 50 psi. Periodically, both of these instruments are certified by an Army Primary Pressure Laboratory which in turn is traceable to the National Bureau of Standards (NBS).

Basically, as described in reference 3, "weights loaded on one end of a piston are supported by fluid pressure applied to the other end." Both gage and absolute measurements may be made with the CEC standard but for general calibration purposes this technique is a slow one. A pressurized gas such as dry nitrogen is introduced through a pressure regulator and valve. Several weight sets are used in conjunction with interchangeable piston and cylinder combinations, providing pressure

increments of 1% for all ranges. The CEC pressure standard is calibrated to an ambient temperature of 75° F. The weights and pistons are based on standard gravity at 45° latitude (980.621 cm/sec<sup>2</sup> at sea level). To determine correct calibration at any given location corrections must be made for gravity, temperature and air buoyancy.

Another technique, both accurate and rapid, is the use of a differential manometer employing fluids of known density. In its simplest form the hydrostatic principle indicates the difference between two column heights and when read correctly is a true indication of the unknown pressure.

The wind tunnel employs several modified versions of this technique. For extended ranges, but readable from floor level, the Meriam Pressurized Manometer is used over a range of 600 cm Hg Abs, and with a readable resolution of one mm Hg (Figure 3). The operation is simple but an ingenious arrangement that, in effect, uses the maximum pressure range of one manometer as a zero reference pressure for a second manometer. A separate source of control air is used to keep the first manometer at its highest readable pressure while the pressure to be measured is connected to the well of the second manometer. The operations are automatic. The fluid will rise until the limiting height of the manometer tube is reached. The technique can be extended to any number of tubes in theory. The pressurized Meriam manometer at this installation has functioned well with three tubes for ten years.

In the lower range of one atmosphere an Exactel servomanometer, model 581 CMA, is used (Figure 4). It is a direct reading cistern type instrument referenced to an established vacuum of less than ten microns Hg. Using mercury as a fluid a range of 80 cm Hg Abs. can be measured in increments of 0.01 cm Hg (100 microns) per scale division. The cistern and tube are housed in a temperature controlled cabinet. Basically, a differential transformer is continuously positioned by a servo to be electrically centered about a float of magnetic material responding to the center of the meniscus. A proportional shaft position in the servo

transmission is analogous to the position of the liquid column. A precision perforated tape is spring loaded and used for the linear transmission, driving over close fitting sprocket pins of a geared shaft. Readout is directly from the output shaft, thru precision gearing to a veeder root counter. The cistern/tube ratio is 40 to 1 with compensating gearing in the servo transmission for cistern level change. Corrections for latitude, gravity, temperature, etc., are built in by trimming the tube to cistern area ratio with vertical rods which decreases the effective area by an exact amount. In the range of 0-80 cm Hg Abs, the Exactel servomanometer has proven to be a reliable instrument. However, in using mercury the manometer resolution of 0.01 cm Hg is inadequate to calibrate a low range transducer. Accuracies of one psia transducers, including nonlinearity, hysteresis, temperature and zero shifts are within 0.25% (F.S.) full scale, i.e.: 0.0125 cm Hg Abs. For the range of one psia and below a modified version of the Exactel manometer is in use. To improve the resolution a low density fluid is used to replace the mercury. The fluid having a specific gravity of less than water, necessitated a redesign of the steel magnetic float assembly. The range of the manometer was, therefore, changed from 80 cm Hg to one psia with a resolution of  $\pm 2$  parts in 7,600. As above, a differential transformer continuously senses and tracks a float on the meniscus and transmits this height by mechanical means to a counter.

The liquid is Dow Corning type D.C. 704 diffusion pump oil with a very low vapor pressure even when hot. At 20° C the vapor pressure is approximately  $10^{-8}$  Torr changing as follows.

The vapor pressure equation

$$\log_{10} P = 11.025 - \frac{5570}{T}$$

where P = vapor pressure, Torr

T = absolute temperature, degree K.

The equation was taken from Dow Corning Silicon Notes, Bulletin 05-032, December 1962.

This manometer (Figure 5) is in a temperature controlled cabinet held above room temperature at 98° F. Calibrations against the CEC air dead weight tester for both manometers have compared satisfactorily to  $\pm 0.05\%$  over the full scale range of each instrument.

To measure absolute pressures with a high degree of accuracy below 0.15 psia an NBS type point contact micromanometer has been placed into operation. It is an instrument that can be calibrated directly in terms of basic quantities and is definitely superior to a McLeod gage over its range. A complete and informative description can be found in the Journal of Vacuum Science and Technology (reference 4). Essentially, the wind tunnel version is a large diameter U-tube utilizing the low density DC 704 fluid (Figure 6). Height readings are accomplished by means of two precision micrometers in the legs rather than through the use of conventional scales and verniers. The instrument incorporates two Starratt micrometer heads, series No. 63, graduated over range 0 to 2 inches to one ten thousandths of an inch. The micrometer shaft is ground to a sharp point and can be viewed accurately as it approaches and dimples the surface of the fluid. Over a range of eight mm Hg, the uncertainties of the instrument vary with a number of intrinsic but controllable factors such as level change, setting, reading, density and temperature. The practical limits associated with this device are considered to be within one micron of mercury over its entire range.

### III. REFERENCE VACUUM SYSTEMS

Stable absolute pressure data, vacuum<sup>5</sup>, must basically be measured from sound foundations. For calibration purposes "zero" pressure levels are established by means of diffusion, ion and mechanical pumps. The diffusion pumped reference vacuum is provided by a Consolidated Vacuum Corporation (CVC) 18 high vacuum station. Figure 7 consists of a chevron baffled, 6 inch diffusion pump (PMC-6B) with a plateau speed of 1,400 liters (air) per second. This pump, Figure 8, is backed up and works in conjunction with a high throughput 15 cubic feet per minute (cfm) forepump Welch model 1397B. The system has a large volume, rapid

pump down capability with a typical performance of evacuating an 18 inch diameter by 30 inch high bell jar to  $1 \times 10^{-6}$  Torr in ten minutes. The system is used in conjunction with leak checking and whenever large volume fast evacuation is necessary. The CVC station has an ultimate pressure limit of  $4 \times 10^{-7}$  Torr on continuous operation.

For the operation and calibration of several of our vacuum standards an ion pumped reference system has been utilized. Essentially, it consists of a 140 liter per minute Welch mechanical pump, coupled by a stainless steel manifold to a Varian 15 liter per second high throughput, sputter-ion pump<sup>6</sup> (Figure 9). The mechanical pump is isolated from the manifold by a molecular sieve trap (Figure 10) and valving. The system operates by initially rough pumping to  $10^{-2}$  Torr and then turning on the ion pump. Once the ion pump has started, the mechanical pump is no longer needed, valved out of the system and turned off. Operating quietly as a Penning Cell (Figure 11), the ion pump keeps the manifold at a vacuum of  $10^{-8}$  Torr or lower. The ion pump has a capability of pumping to  $10^{-10}$  Torr region in a clean baked out system. In wind tunnel service, the pump and manifold are coupled with two manometers containing PC 704 fluid. The ultimate pressure of the complete system stabilizes at  $5 \times 10^{-7}$  Torr and has been in service for over three years.

The pump element's useful life below  $10^{-4}$  Torr is inversely proportional to the pressure at which the pump is operated. With continuous operation at  $10^{-6}$  Torr, a typical pump element will function for more than 40,000 hours. Pumping speed of this pump is apparently constant over a wide pressure range. Figure 12 shows the speed for air as a function of pressure. Speeds for other gases as a percent of the speed of air are listed.

To monitor the vacuum level in this system a single control unit operates two Varian ion gages over a range of one Torr to  $2 \times 10^{-11}$  Torr. These are nude gages (Figure 13), relatively accurate, reliable and have a good response throughout the pressure range. The Varian pump can also be used to measure system pressure by acting as a cold cathode type gage

(Figure 14). The pressure can be monitored on a log scale or by reading the pump current which is linear with pressure between  $10^{-3}$  and  $10^{-8}$  Torr. Above and below this range, the ion gages are essential.

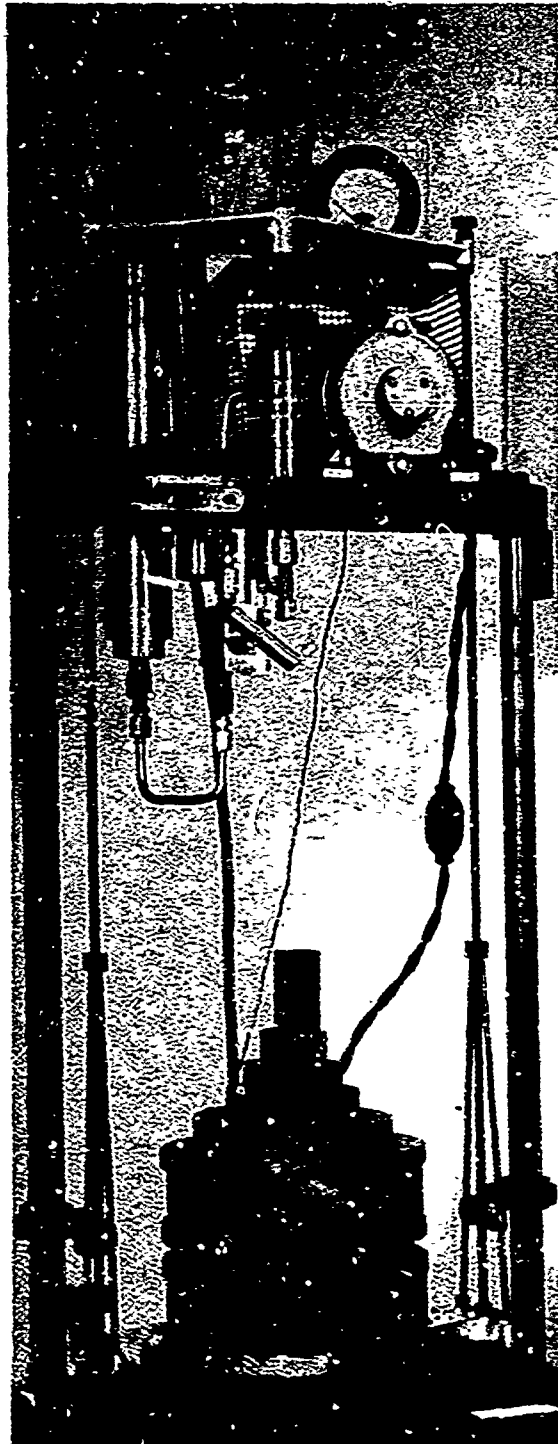

Figure 1. Oil Dead Weight Tester



Figure 2. Air Dead Weight Tester

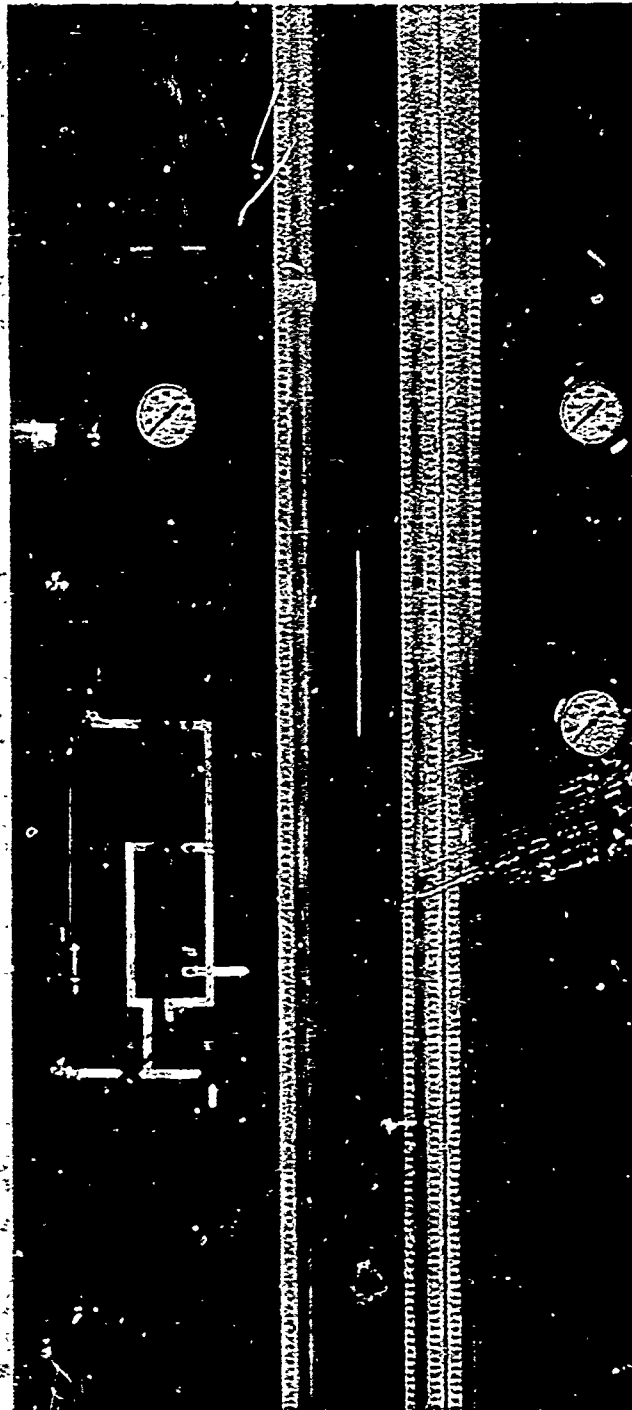

Figure 3. Three Stage-Pressurized Manometer Range 600 cm Hg Abs

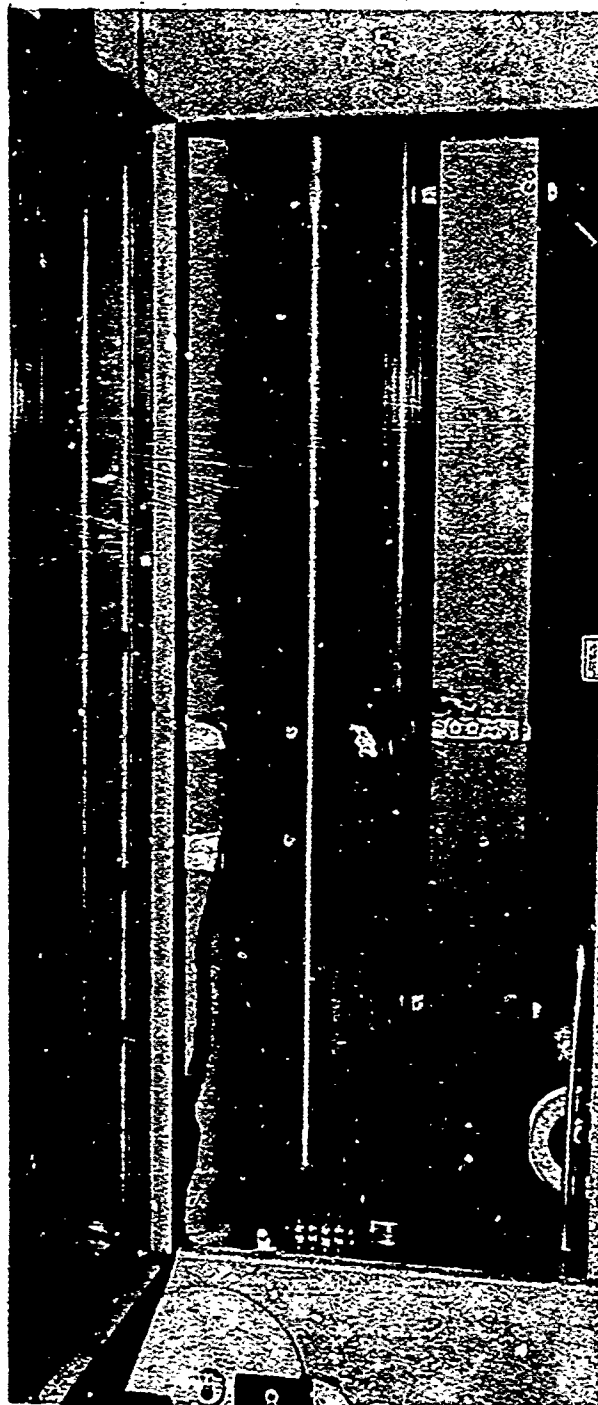

Figure 4. Mercury Servomanometer Range 80 cm Hg Abs

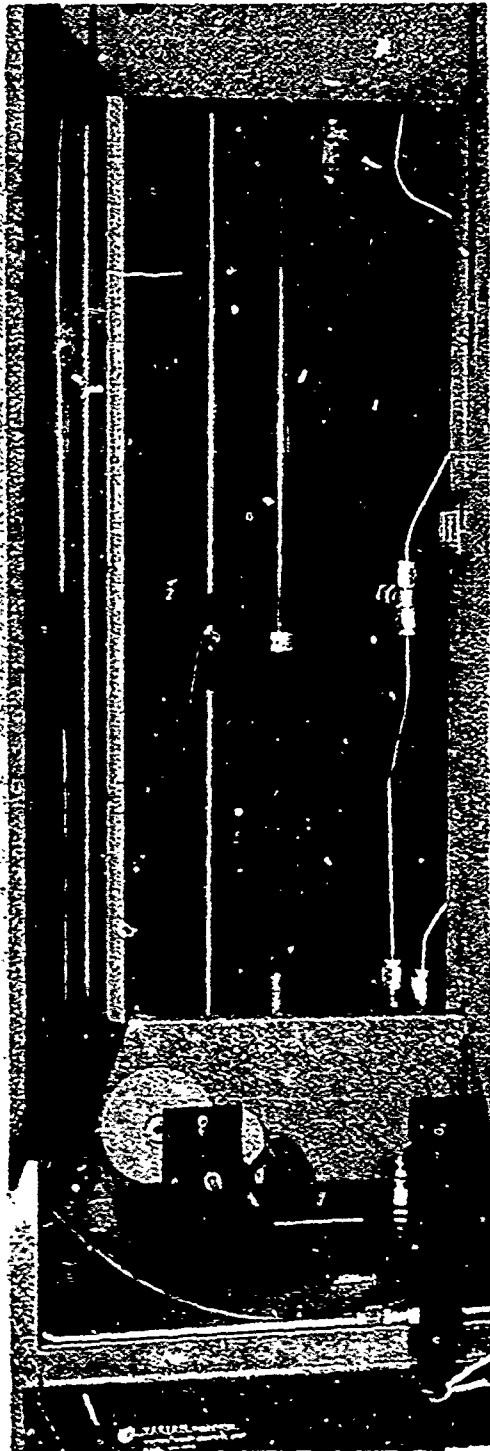

Figure 5. Oil Servomanometer Range 1 psia

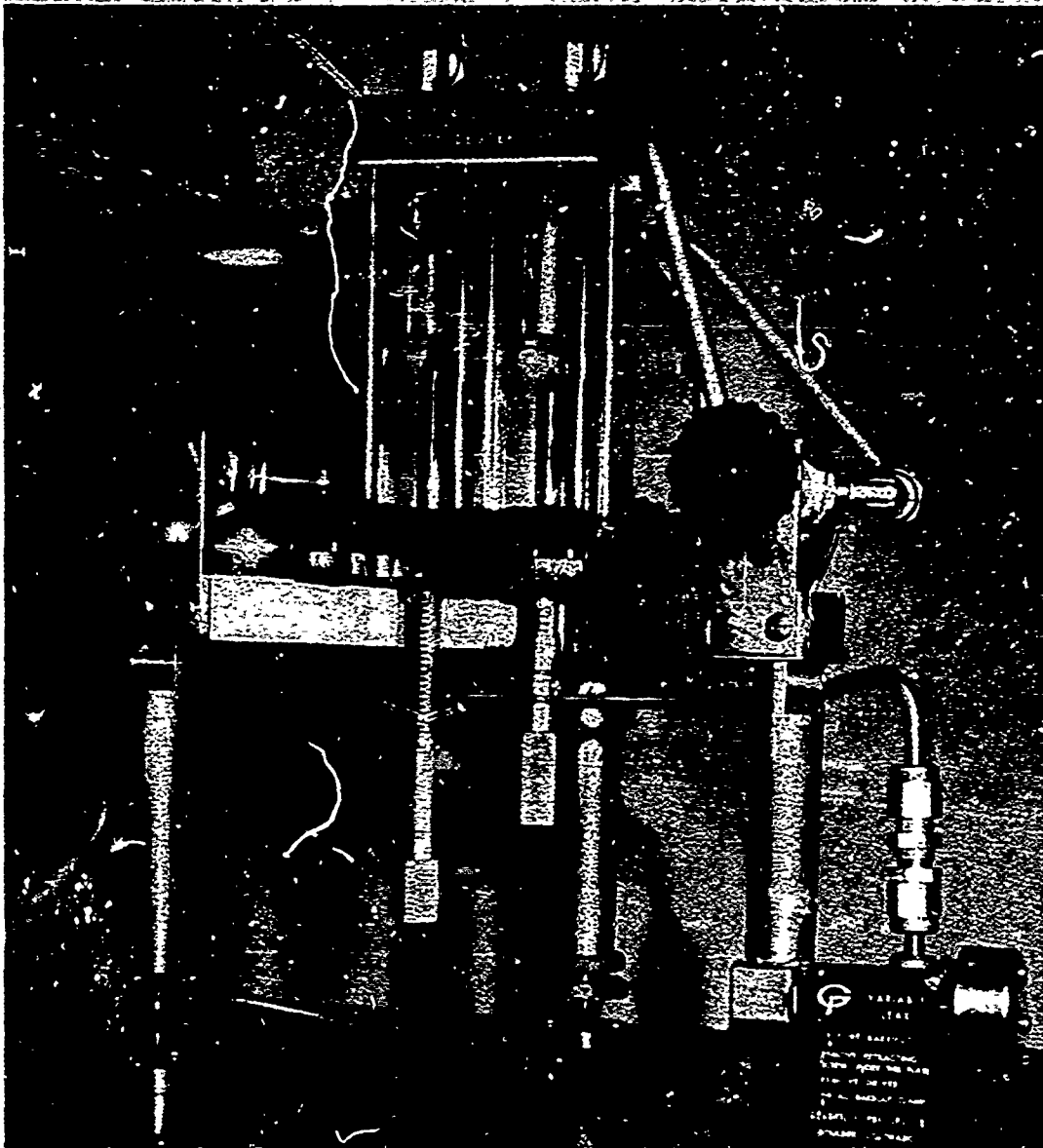

Figure 6. Print Contact Manometer Range 8 mm Hg Abs

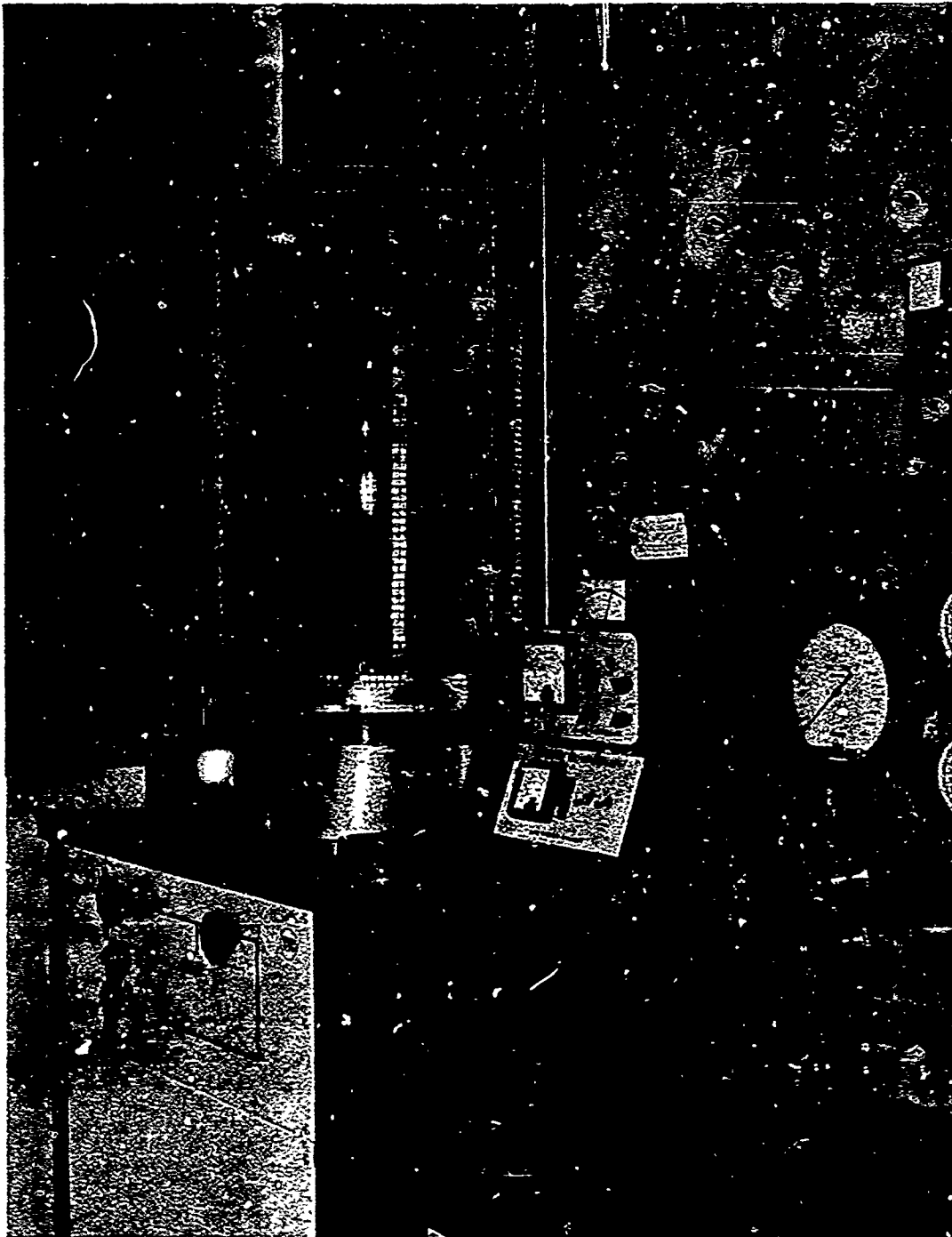

Figure 7. Bell Jar Pump Station

**SCHEMATIC VALVE & FLOW DIAGRAM**

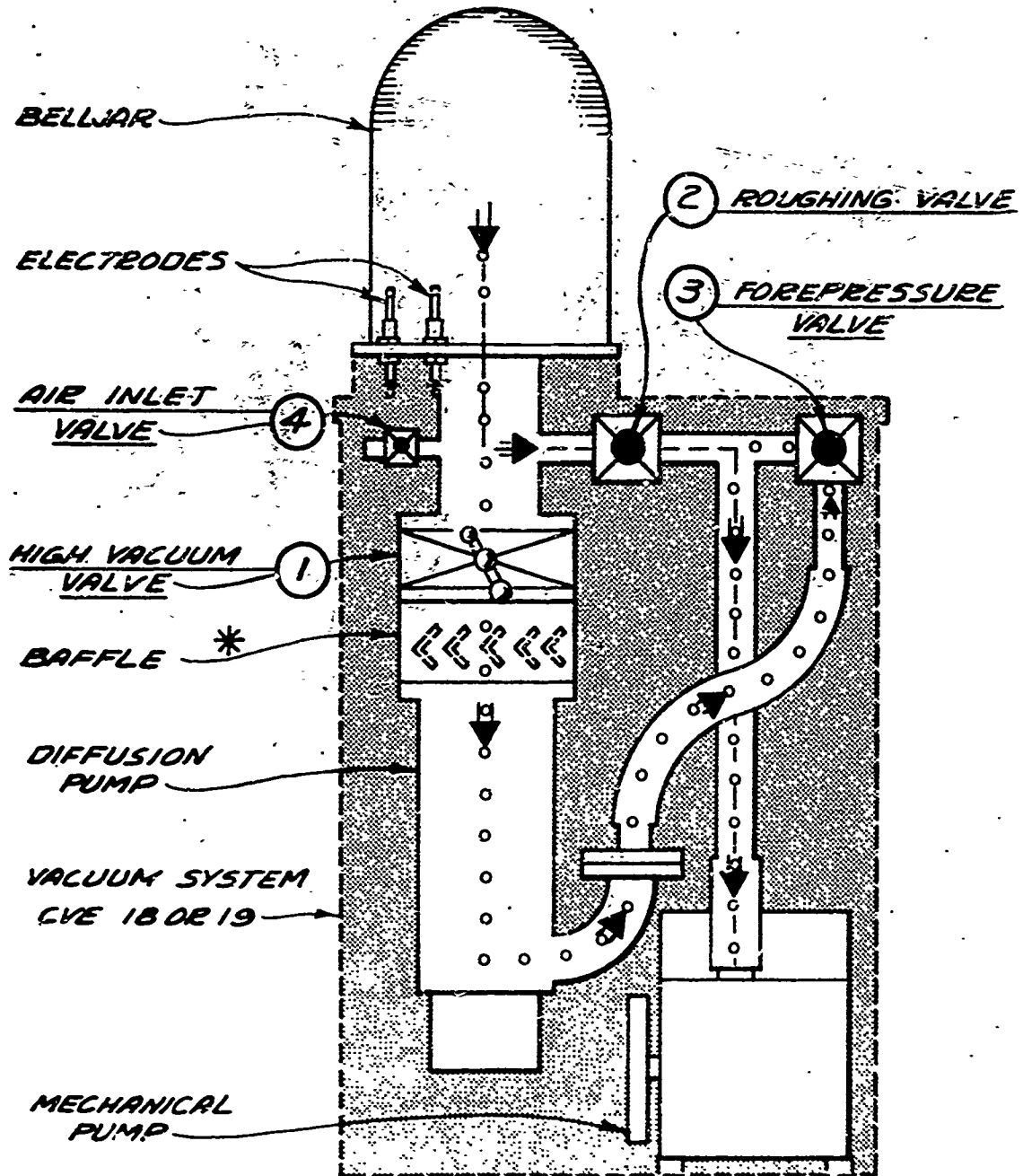
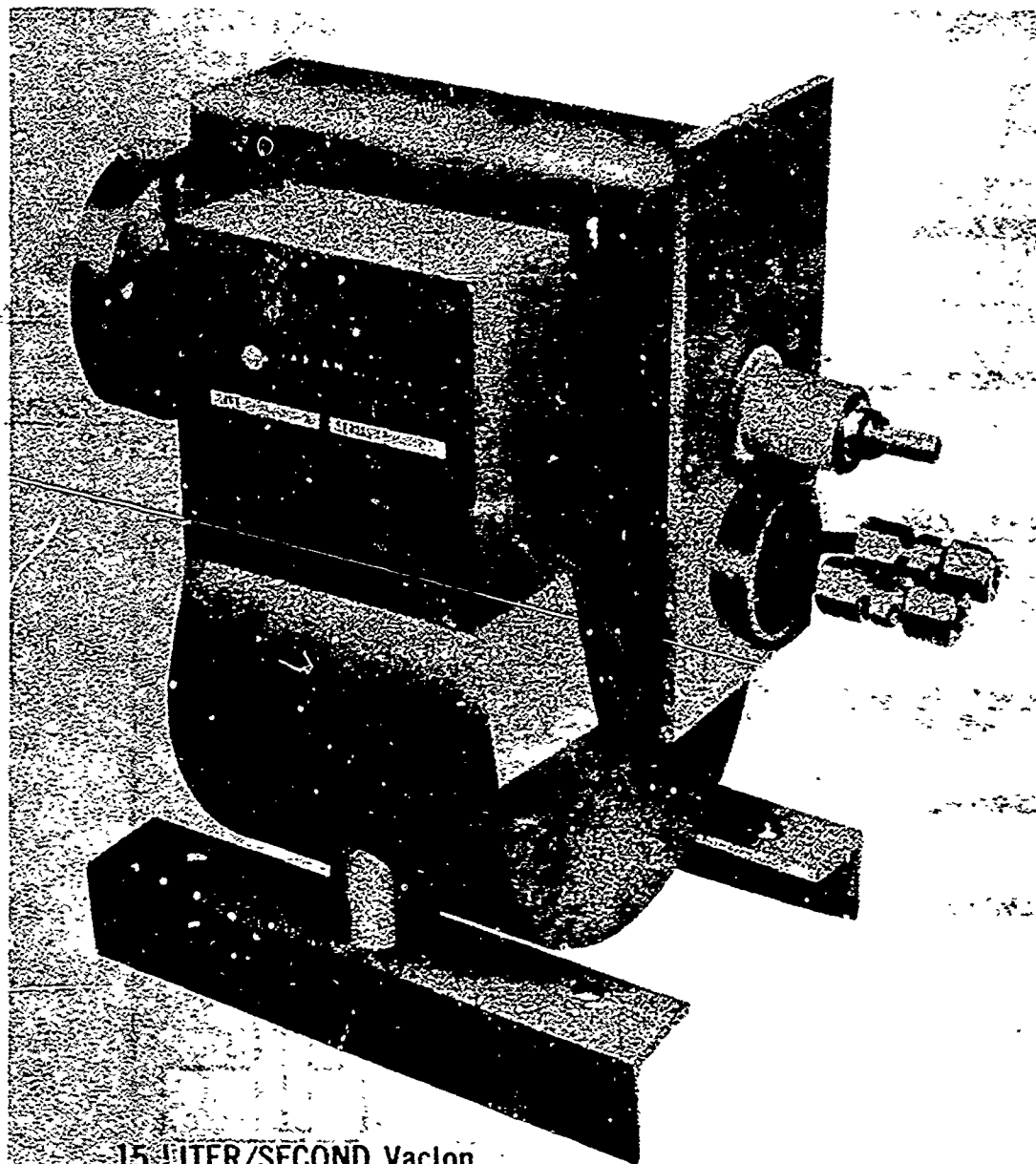

Figure 8. Schematic Flow Diagram Pump Station



15 LITER/SECOND Vaclon  
HIGH THROUGHPUT PUMP AND MAGNET

Figure 9. Sputter-Ion Pump

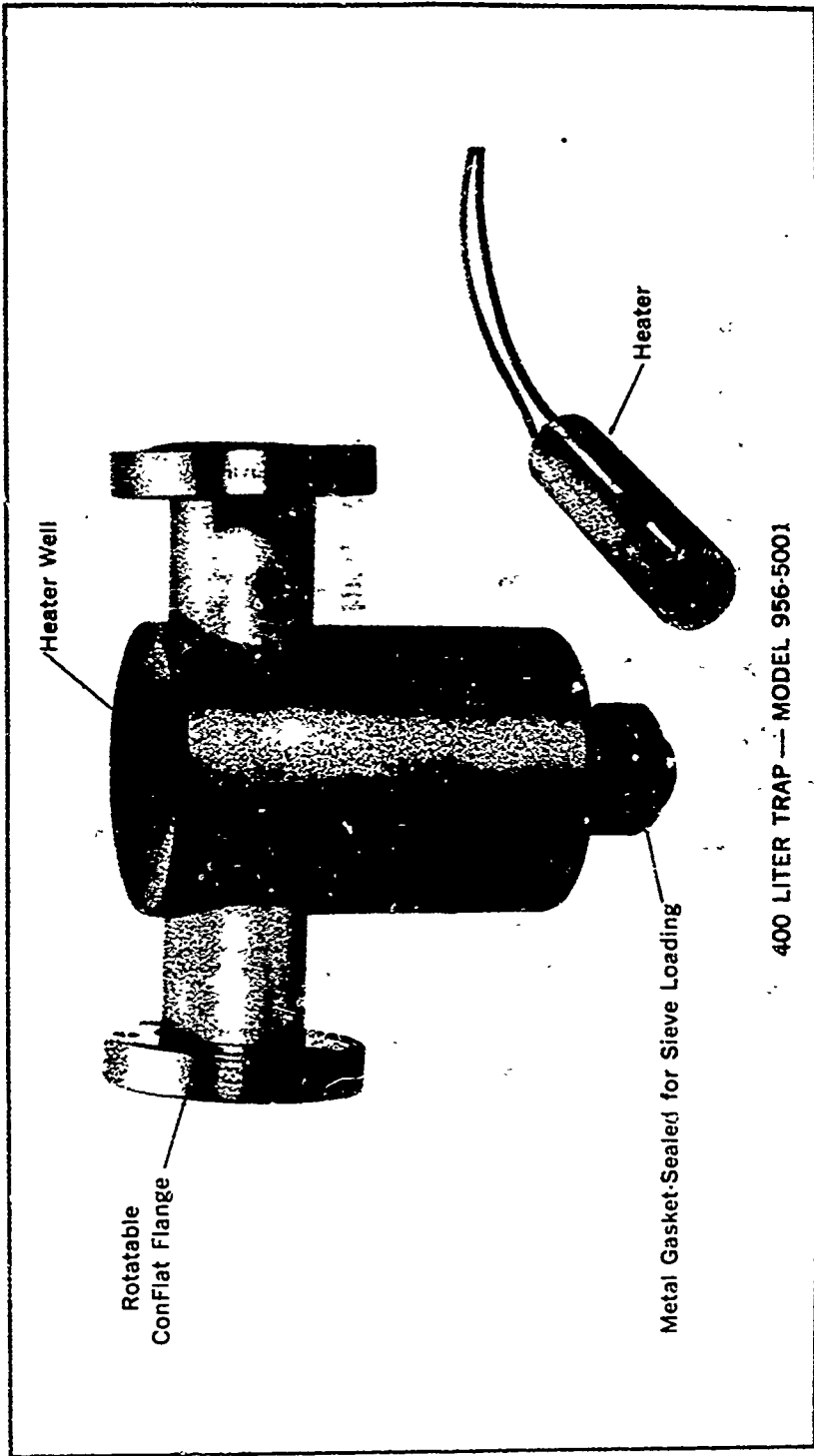
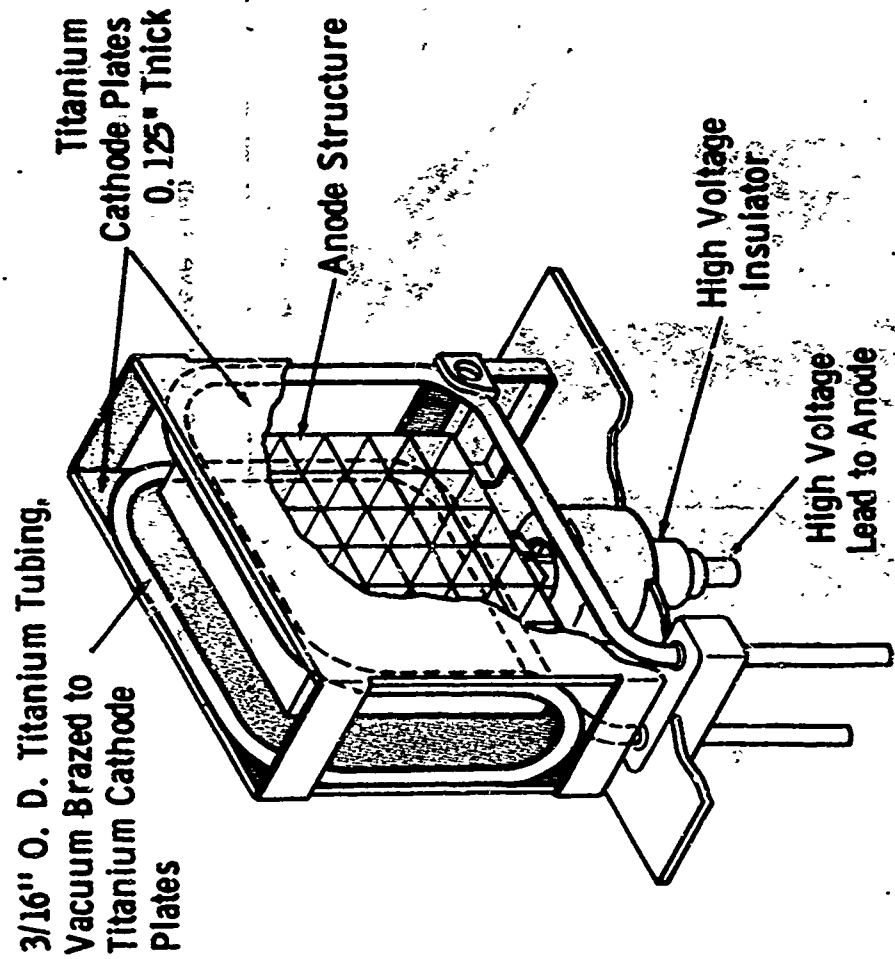

Figure 10. Molecular Sieve Trap



CUTAWAY SKETCH OF PUMPING CELL OF THE  
15 L/S WATER COOLED VACUUM PUMP

Figure 11. Ion Pump--Internal Construction

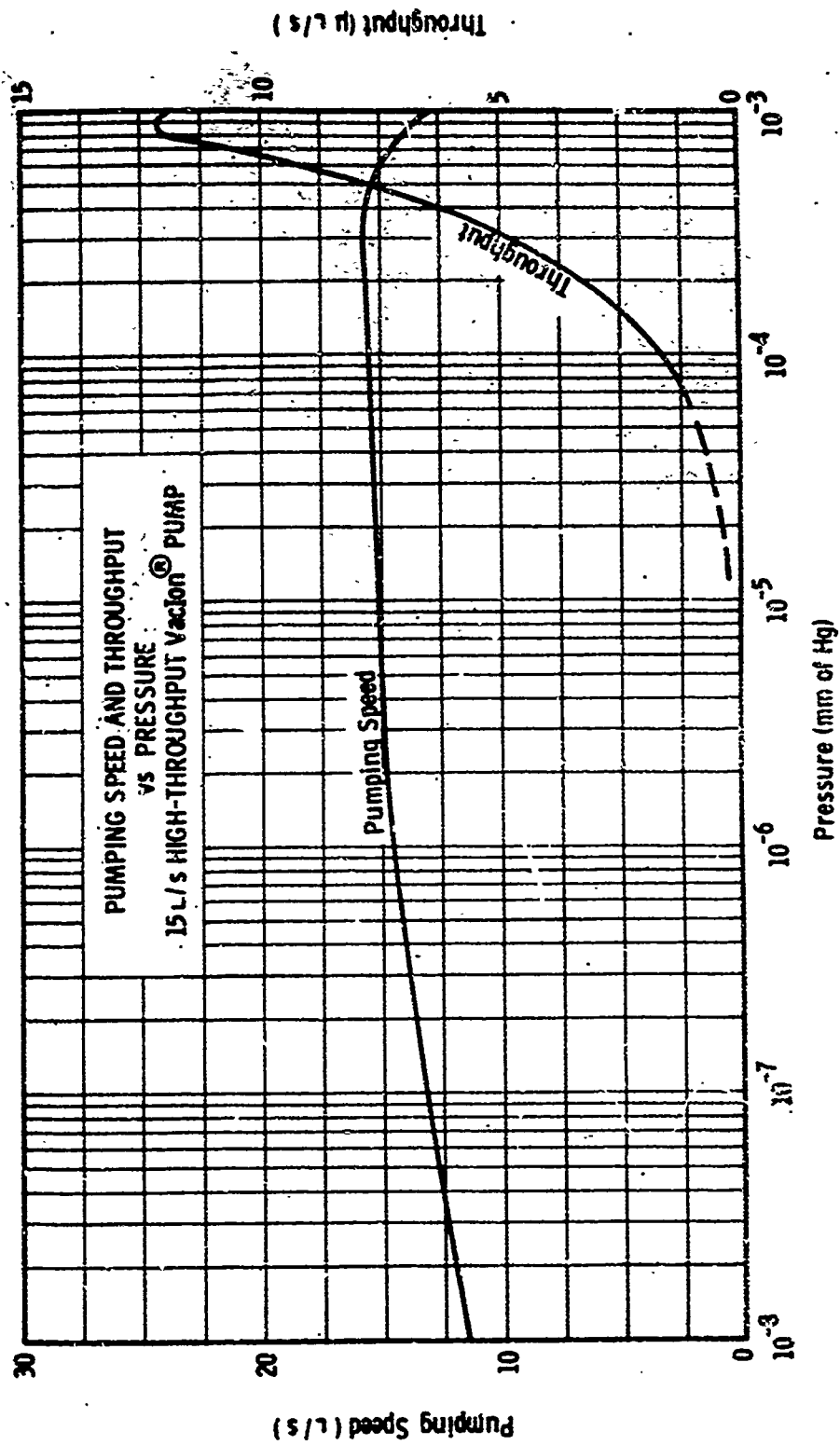

Figure 12. Ion Pump Speed Versus Pressure

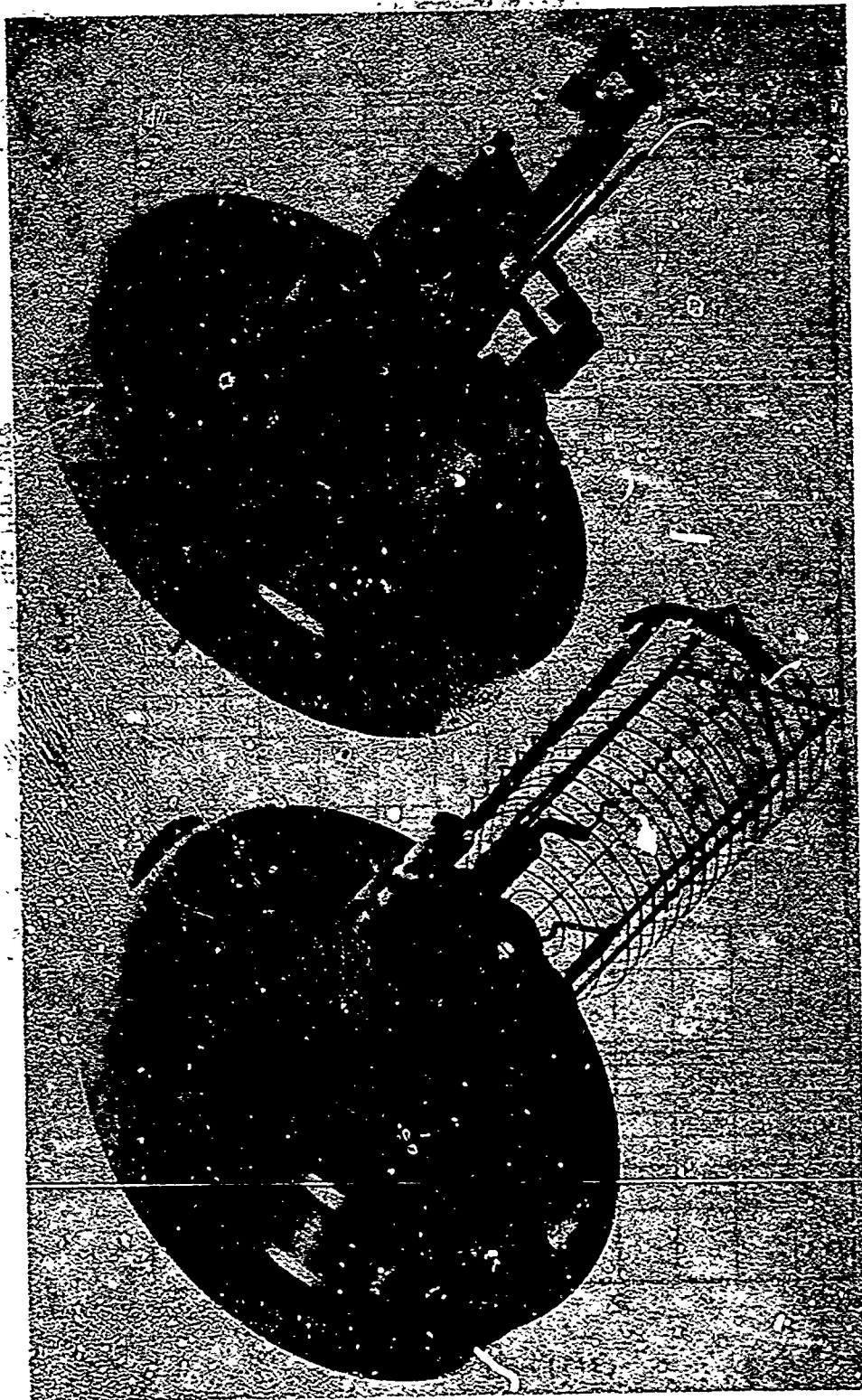
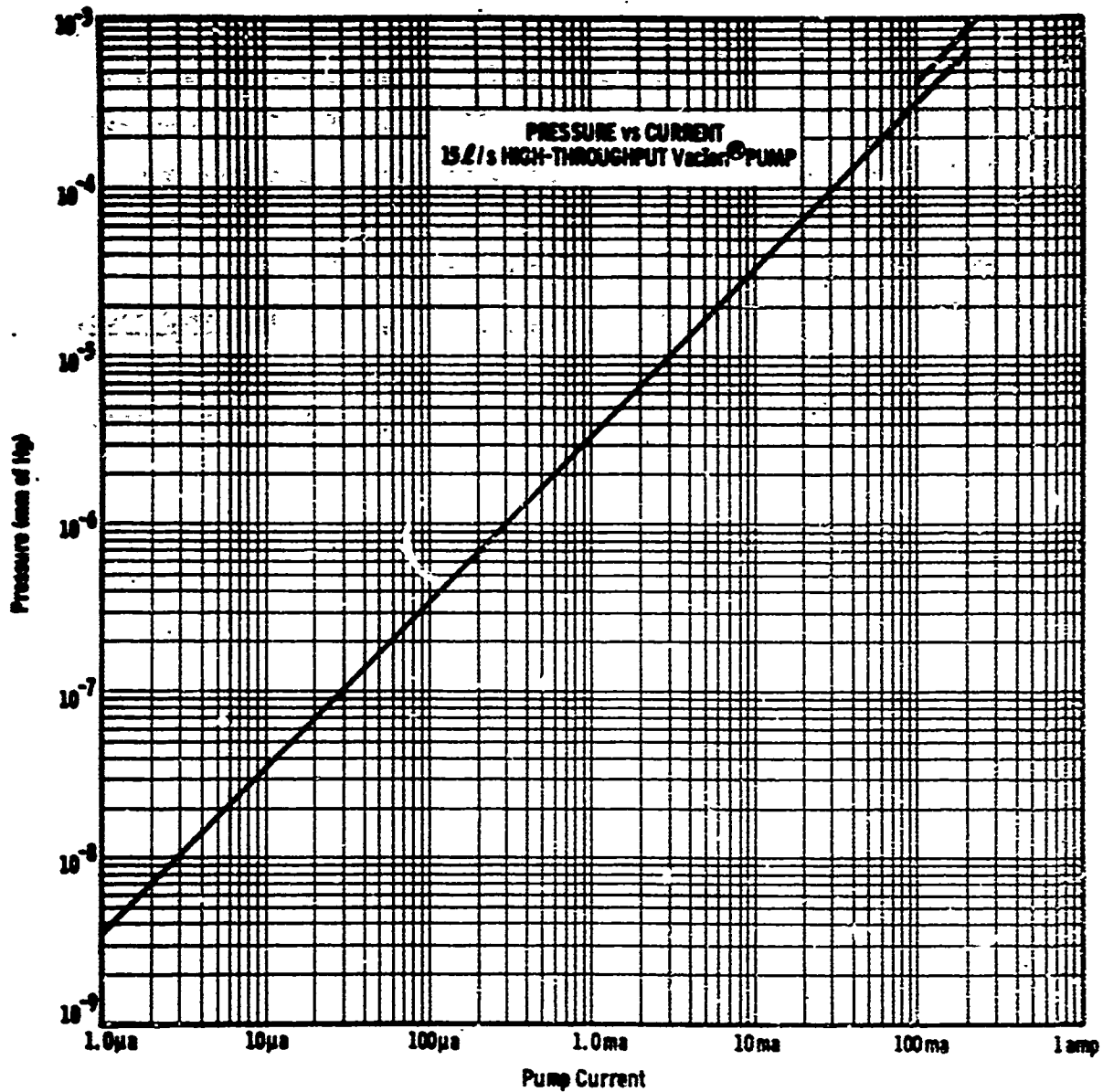

Figure 13. High and Low Range Nude Ion Gages



**PRESSURE DETERMINATION OVER THIS RANGE IS COMPARABLE TO THAT OF GOOD IONIZATION GAUGES**

Figure 14. Ion Pump Current Versus Pressure

#### REFERENCES

1. J. C. McMullen, "Wind Tunnel Testing Facilities at BRL," BRL Memorandum Report 1292, July 1960.
2. R. Colburn, "Pressure Scanner Unit," BRL Technical Note 1516, June 1966.
3. J. L. Cross, "Reduction of Data for Piston Gage Pressure Measurements," National Bureau of Standards Monograph No. 65, 17 June 1963.
4. A. M. Thomas and J. L. Cross, "Micrometer U-tube Manometer for Medium-Vacuum Measurements," *The Journal of Vacuum Science and Technology*, Volume 4, No. 1, January/February 1967.
5. Donald J. Santeler, et. al, Vacuum Technology and Space Simulation, NASA-SF-105, Page 8, 1966.
6. Alfred E. Barrington, High Vacuum Engineering, Prentice Hall, Page 114, 1963.