

MARINE PHYSICAL LABORATORY  
 of the Scripps Institution of Oceanography  
 San Diego, California 92152

SEA FLOOR TECHNOLOGY  
 REPORT No. 2

ORB - RUM OPERATIONS  
 MARCH THROUGH AUGUST 1970

Victor C. Anderson  
 Daniel K. Gibson

Sponsored by  
 Office of Naval Research  
 N00014-69-A-0200-6002  
 N00014-69-A-0200-6002

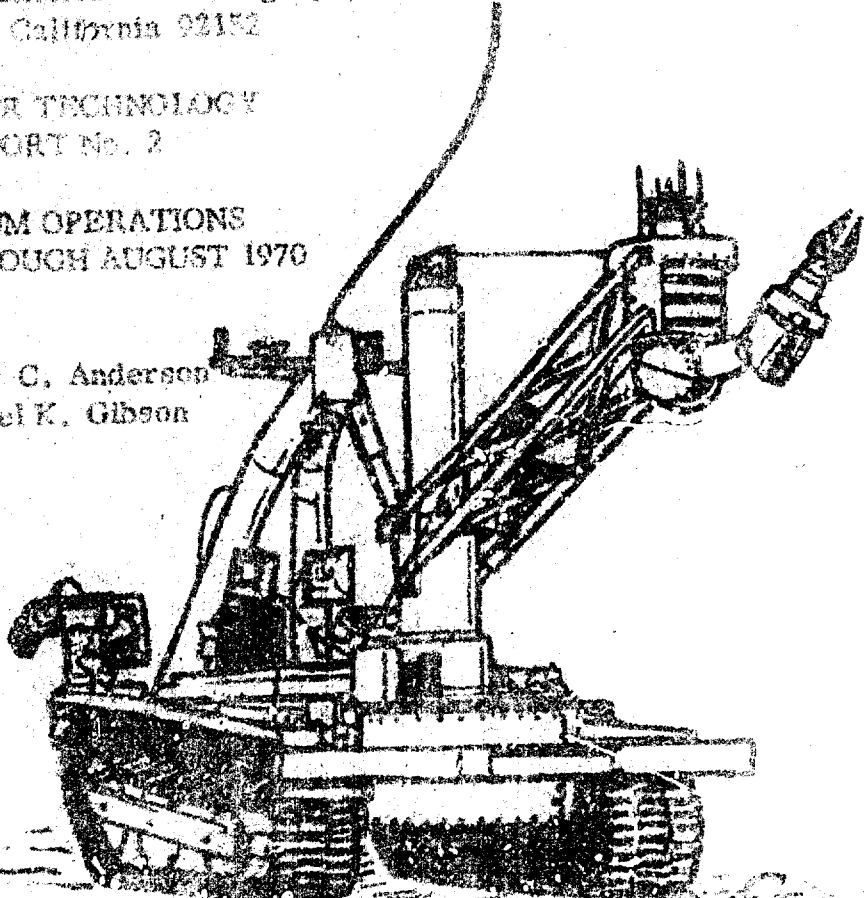

NAVY TECHNICAL  
 INFORMATION SERVICE

15 January 1972

SIO REFERENCE 71-29

**Best Available Copy**

Reproduction in whole or in part is permitted  
 for any purpose of the U. S. Government.

Document cleared for public  
 release, for distribution to unclassified

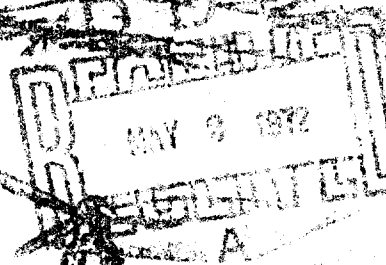

740804

**Best  
Available  
Copy**

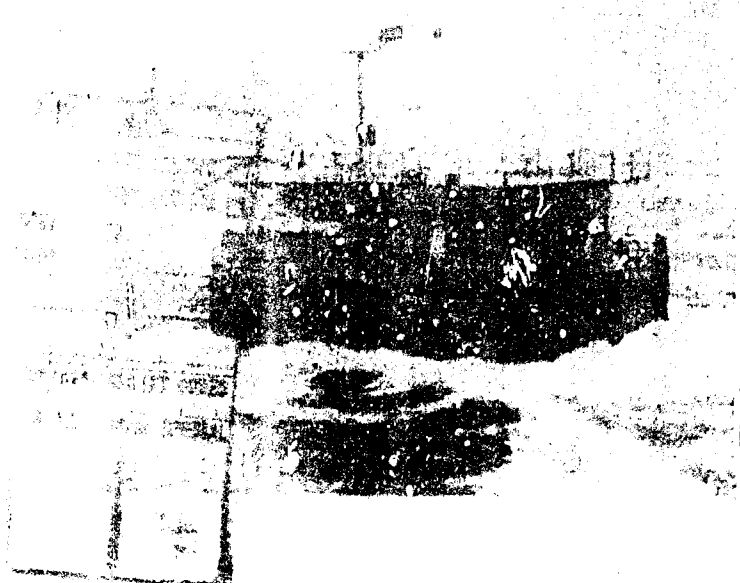

"ORB" Oceanographic Research Buoy

ORB, a 45-foot square vessel displacing approximately 180 tons, was developed by the Marine Physical Laboratory to serve projects at the laboratory which require the launch, retrieval, installation or handling of large equipments or systems in the deep ocean. Among these are:

1. "RUM" (remote underwater manipulator) remotely controlled, bottom crawling vehicle.
2. "Senthic Laboratory"; an electronic control and data transmission center, remotely located and maintained on the sea floor.
3. Acoustic transducers and hydrophone arrays.

In contrast to WLEP, ORB is designed to follow the motion of the sea surface as closely as possible, in order to simplify the task of placing and retrieving large objects in the ocean. The vessel has a center well of 15- by 20-foot area which can be opened to permit equipment to be lowered through it. Loads up to 12 tons are safely handled with a system that includes a number of automatic control features, and can be lowered to a maximum depth of 10,000 feet. The supporting cable also serves simultaneously to transmit as much as 30 kilowatts of power to the remote equipment, and to return from it a variety of data, including television video signals.

ORB is 24 feet high from keel to helicopter deck. It has no means of self-propulsion and must be towed to and from operating areas. The vessel is equipped with diesel generating sets to provide 90 kilowatts of electrical power. ORB's equipment also includes a normal amount of navigation aids, communication and safety equipment. It carries fuel and water for a stay of up to 45 days while moored on station. Personnel rotation at sea where necessary may be accomplished by either small boat or helicopter.



"RUM" Remote Underwater Manipulator

RUM is a remotely controlled, tracked sea floor work vehicle which has been developed under the sponsorship of the Office of Naval Research at the Marine Physical Laboratory for use as a research tool in sea floor technology experiments.

The hull, tracks and suspension system of the RUM vehicle are those of an "ONTCS," a surplus Marine Corps tracked rifle.

All power, telemetry for control and instrumentation, sonar, navigation aids and television are transmitted over the single coaxial umbilical cable connecting the RUM to ORB.

The vehicle is propelled by two independently controlled reversible 7-1/2 horsepower direct current motors, one driving each track. Other equipment includes two television cameras, eight 500 watt lights, a scanning sonar, depth sounder, magnetic compass, an acoustic transponder navigation system and numerous other kinds of instrumentation to monitor operational conditions.

All of the electrical and electronic components with the exception of the TV cameras and lights are immersed in oil and operate at ambient pressures of up to 5000 psi.

The manipulator is capable of working off of either side or to the rear of the vehicle and is capable of exerting 50 pounds of force in any direction at full arm's length. In addition the manipulator boom is equipped with a hook capable of lifting loads of up to 1000 pounds and moving them about on the ocean floor. The manipulator boom swings in an arc of about 300° around a king post located at the rear center of the vehicle. The boom is raised and lowered by a motor-driven wire rope topping lift.

Reproduced from  
best available copy.

UNCLASSIFIED

Security Classification

DOCUMENT CONTROL DATA - R & D

(Security classification of title, body of abstract and indexing annotation must be entered when the overall report is classified)

1. ORIGINATING ACTIVITY (Corporate author) University of California, San Diego, Marine Physical Laboratory of the Scripps Institution of Oceanography, San Diego, California 92152		2a. REPORT SECURITY CLASSIFICATION UNCLASSIFIED	
		2b. GROUP	
3. REPORT TITLE  SEA FLOOR TECHNOLOGY REPORT No. 2 ORB - RUM OPERATIONS MARCH THROUGH AUGUST 1970			
4. DESCRIPTIVE NOTES (Type of report and inclusive dates) Progress			
5. AUTHOR(S) (First name, middle initial, last name)  Victor C. Anderson and Daniel K. Gibson			
6. REPORT DATE 15 January 1972	7a. TOTAL NO OF PAGES 11	7b. NO. OF REFS 4	
8a. CONTRACT OR GRANT NO. N00014-69-A-0200-6002 NR 260-103	9a. ORIGINATOR'S REPORT NUMBER(S)  SIO Reference 71-29		
b. PROJECT NO	9b. OTHER REPORT NO(S) (Any other numbers that may be assigned this report) MPL-U-80/71		
c.			
d.			
10. DISTRIBUTION STATEMENT  Document cleared for public release; its distribution is unlimited.			
11. SUPPLEMENTARY NOTES		12. SPONSORING MILITARY ACTIVITY  Office of Naval Research	
13. ABSTRACT  Three successive operations with the ORB - RUM sea floor work system in water depths of 100 to 3300 feet are described. Operational experience gained, technical problems encountered and their solutions are areas of particular interest.			

Details of illustrations in this document may be better shown on separate sheets

O D C  
RECORDED  
1973  
INDEXED  
A

14

KEY WORDS

LINK A

LINK B

LINK C

ROLE

WT

ROLE

WT

ROLE

WT

UNIVERSITY OF CALIFORNIA, SAN DIEGO  
MARINE PHYSICAL LABORATORY OF THE  
SCRIPPS INSTITUTION OF OCEANOGRAPHY  
SAN DIEGO, CALIFORNIA 92152

SEA FLOOR TECHNOLOGY  
REPORT No. 2

ORB - RUM OPERATIONS  
MARCH THROUGH AUGUST 1970

Victor C. Anderson and Daniel K. Gibson

Sponsored by  
Office of Naval Research  
N00014-69-A-0200-6002  
NR 260-103

Reproduction in whole or in part is permitted  
for any purpose of the U. S. Government.

Document cleared for public  
release; its distribution is unlimited.

15 JANUARY 1972

SIO REFERENCE 71-29



---

F. N. SPIESS, DIRECTOR  
MARINE PHYSICAL LABORATORY

MPL-U-80/71

SEA FLOOR TECHNOLOGY  
REPORT No. 2

ORB - RUM OPERATIONS  
MARCH THROUGH AUGUST 1970

Victor C. Anderson  
Daniel K. Gibson

University of California, San Diego  
Marine Physical Laboratory of the  
Scripps Institution of Oceanography  
San Diego, California 92152

ABSTRACT

Three successive operations with the ORB - RUM sea floor work system in water depths of 100 to 3300 feet are described. Operational experience gained, technical problems encountered and their solutions are areas of particular interest.

Introduction

The ORB - RUM sea floor work system has been taken to sea four times for the express purpose of gaining operational experience and for system test, evaluation and debugging. The first operation was conducted in January 1970 and has been described in detail in a previous report.<sup>1/</sup> The other three are described herein.

By August 7th RUM had logged a total of 115 hours of operation on the sea floor out of approximately 350 hours on station at sea. Of the total operating hours, 55-1/2 have been in shallow water of 40 to 150-foot depth where 51,150 feet of traverse over the bottom were logged. Most of the shallow water operations were on firm sandy bottom where RUM could serve as a mobile anchor towing ORB along on the sea surface above. In addition some limited experience maneuvering in soft silt and over cobbles was also gained.

Deeper operations at 1200 to 3400-foot depths account for the remaining 59-1/2 hours on the bottom. These operations were in the very soft sedi-

ments on the floors of the La Jolla Canyon and the San Diego Trough over which a total of 4400 feet of traverse were logged. The longest single continuous operation was on the floor of the La Jolla Canyon lasting 29-1/2 hours on August 5th and 6th.

Of the 115 hours total operation, approximately 37 were devoted specifically to exploratory maneuvers designed to develop and improve operating skills and techniques. Twenty five hours were spent in maneuvers providing a free field calibration of the magnetic compass. Twenty-four hours of search and recovery exercises were carried out. Twenty hours were devoted strictly to functional checkout of the system and about nine hours of manipulation have been logged.

Shallow Water Operations - March 14-20

The chart (Figure 1) shows the three areas in which operations were conducted. The first area, for the March 14th, 15th and March 19th and 20th operations located at 117°12'W, 32°32.5'N, was chosen for its relatively flat, medium sandy bottom, and for its near shore location with good landmarks

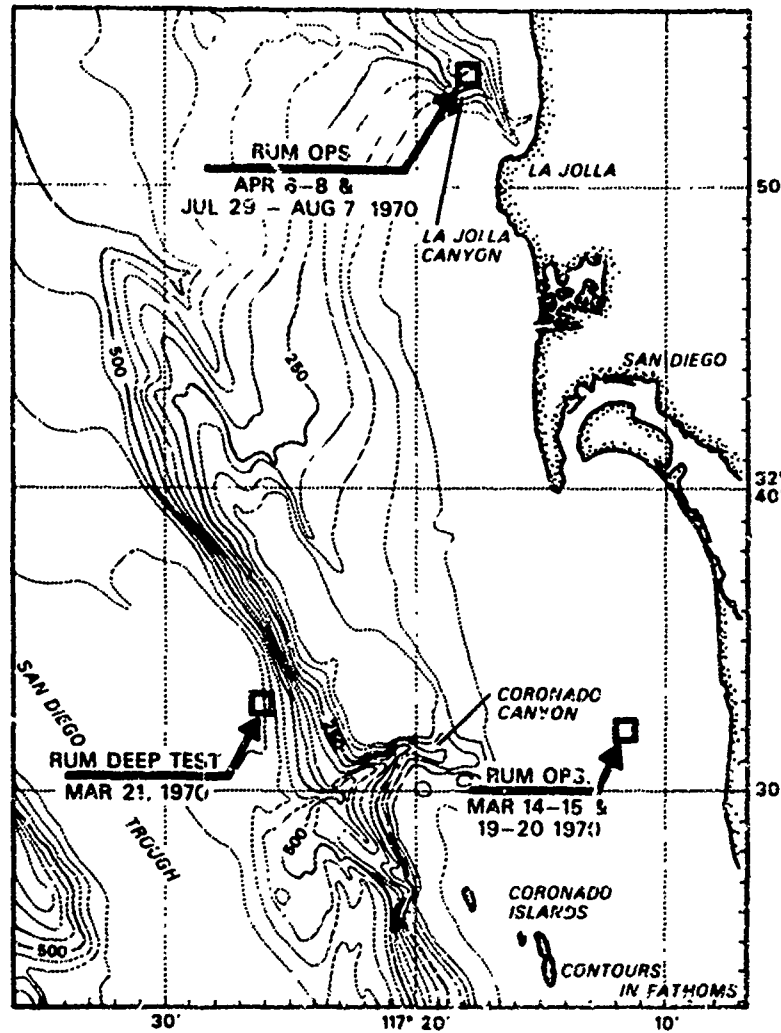

Fig. 1. Operating areas.

for visual verification of base lines selected for the placement of acoustic navigational transponders. The primary objective of this operation was to obtain a free field calibration of the RUM magnetic compass. The flat firm bottom made it possible to hold the RUM vehicle on a steady compass heading over large enough distances to obtain a reasonably accurate compass calibration by comparison with the track of the vehicle position as obtained from the well-established transponder field. RUM was driven on magnetic compass headings of  $000^\circ$ ,  $022.5^\circ$ ,  $045^\circ$ ,  $067.5^\circ$  and so on at  $22.5^\circ$  course changes to  $337.5^\circ$ . A distance of 700 feet or more was driven on each course with position plotted at the beginning and end of each run by measuring range to the three transponders. The true course of the vehicle was ob-

tained by drawing a line through the plotted start and finish positions. The compass calibration obtained by drawing a smooth curve through these  $22.5^\circ$  data points is shown in Figure 2. Distance traveled as indicated by track turns counts on the vehicle, agreed very well with distance between plotted positions. All errors were less than 5%.

During this entire exercise of over 22 hours, RUM was operated with a track pressure of 1.5 to 1.75 psi (cable tension of 5 to 6 thousand pounds). A total distance of over 3-1/2 miles was driven with RUM towing ORB along on the sea surface overhead.

The acoustic transponders were equipped with surface floats, attached by line, for easy

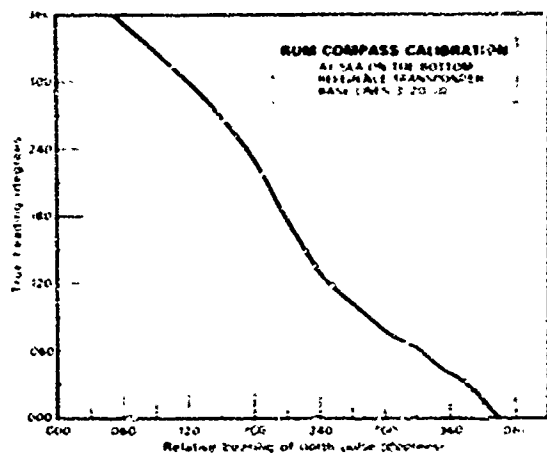

Fig. 2. Compass calibration

recovery. During the recovery operation, RUM was driven right up to each transponder so that the surface float could be picked up from the deck of ORB with a boat hook. The water depth ranged from 110 to 120 feet.

#### Deep Water Operations - March 21

The first deep test of RUM was carried out on the following day, March 21st, in 3300 feet of water at 117°26.15'W, 32°33'N. ORB was held in position by a single point deep moor during this operation.

TV viewing in the mid-water depths on the way to the bottom was outstanding with objects clearly visible at 15 feet with little visible back scatter. The visibility on the bottom, although not as good as in the mid-water depths, was superior to any experienced in the previous shallow water tests. A couple of starfish walking away from the vehicle and some sea urchins were identifiable at an estimated distance of 8 to 10 feet.

Limited time on the bottom did not allow for determination of optimum track pressure, however the experience did indicate that the vehicle would probably have to be operated at something less than 1 psi track pressure in order to maneuver over the soft sediment encountered. In addition to the general clouding of the water, caused by the moving vehicle churning up the bottom, a well-defined, low dense turbidity cloud was observed to roll out from under the vehicle and across the sea floor at a velocity of a few inches per second. The height of this cloud appeared never to exceed a few inches, probably less than one foot. This low heavy cloud

seemed to be unaffected by current, always rolling out in the direction of vehicle motion while the general overall clouding was swept away in the down-current direction.

Another phenomenon observed, was that as the vehicle was driven and sediment accumulated in the tracks, the vehicle weight increased forming a regenerative system wherein the increased weight caused deeper penetration which in turn caused greater sediment accumulation. At one point the vehicle weight was noted to have increased 3000 lbs between set down and lift off. Although a depth related problem with power control contactors in RUM forced an early termination of these tests, a good deal of valuable experience was gained during the one hour of operation in the unfamiliar deep sediments.

#### Power Contactor Failures

Upon return to port, a careful inspection revealed that all power control contactor failures, which had occurred during this last deep test of the vehicle, were associated with a particular type of contactor. These were found to have badly burned contacts and extensive carbon deposit build-up in the contact area, even to the point of actually bridging across the contacts in some cases. All contactors of this type used for power control were replaced by another type having larger contacts and wider contact spacing. The type used for replacement was selected strictly on the basis that several had already seen limited service in the vehicle without failure up to this date.

#### La Jolla Canyon Operations - April 6-8

Any other known system deficiencies were corrected and ORB returned to sea on April 6th for operations at 1285 to 1300-foot depth on the floor of the La Jolla Canyon. The location for this operation near 117°18.5'W, 32°53.5'N is also noted on the chart (Figure 3). Precision positioning of ORB over the narrow La Jolla Canyon was accomplished by using radar ranges to the head of the Scripps pier, 2-1.2 to 3 miles away, and transit bearings to ORB taken by a transit team on the head of the pier. Continuous radio communications between ORB and the transit team were maintained.

ORB was towed slowly into position, guided by the tracking team, for the placement of each of 2 anchors set on a northwest-southeast baseline, at approximately one mile separation. The RUM operating area was nearly midway between the two anchors. Figure 3 shows the approximate anchor implant locations and the canyon topography in the im-

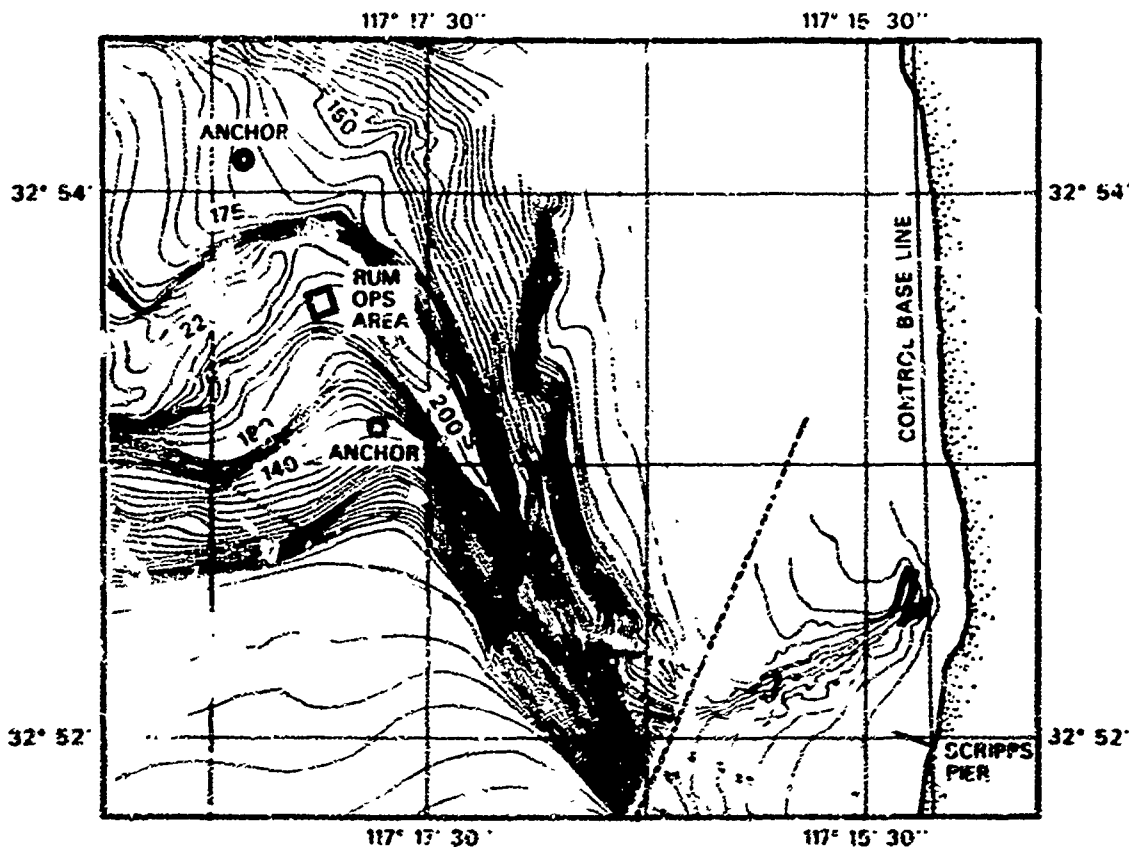

Fig. 3. La Jolla Canyon operating area.

mediate area. The anchors and lines were handled from the deck of ORB.

Over 13 hours of operation on the floor of the canyon were logged between 0130 and 1800, April 7th.

RUM was driven on a series of courses and speeds at track pressures from 0.25 to 1.5 psi. It was determined that at track pressures in excess of 0.5 psi, RUM soon bogged down in the soft sediments. The regenerative condition wherein RUM gained weight from accumulated silt in the tracks was again experienced. At a track pressure of 0.25 psi difficulty with steering was experienced. A track pressure of 0.4 to 0.5 psi was used for the remainder of the operation.

It was also noted that when RUM was driven a distance of 80 to 120 feet away from a point directly under ORB, forward motion would be lost indicating that traction slippage had occurred. This condition occurs at an estimated 5 to 7 degree wire

angle. Using this wire angle and the wire tension of approximately 10,000 lbs. one can compute a horizontal force component thereby providing a rough estimate of maximum drawbar pull capability of the vehicle. The estimate obtained under these conditions was 1000 lbs.

The manipulator was deployed, checked out and the grip swung in an arc scribing a line across the track depression in an effort to estimate its depth. Estimates, by various people present and viewing the act on TV, varied from 3 to 6 inches. The failure of a power contactor controlling the raise-lower function of the manipulator derrick prevented the carrying out of any serious manipulation tasks.

Visibility was quite good and a number of polaroid pictures were taken of the TV display. Problems with the video recorder prevented recording of the TV scene other than the polaroid snapshots. Figures 4 and 5 are representative of the pictures taken. In Figure 4 a large fish is seen near

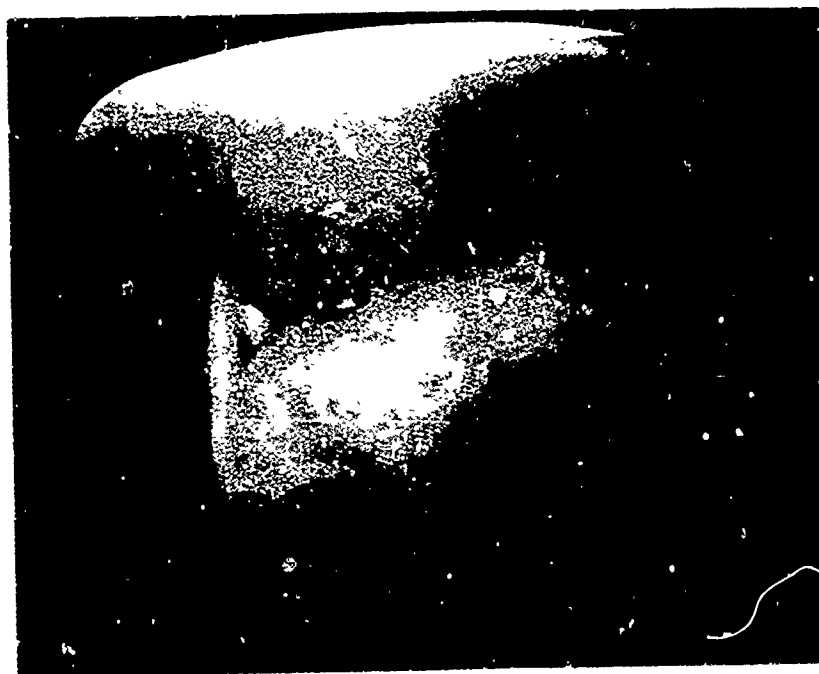

Fig. 4. TV view of large fish in front of vehicle.

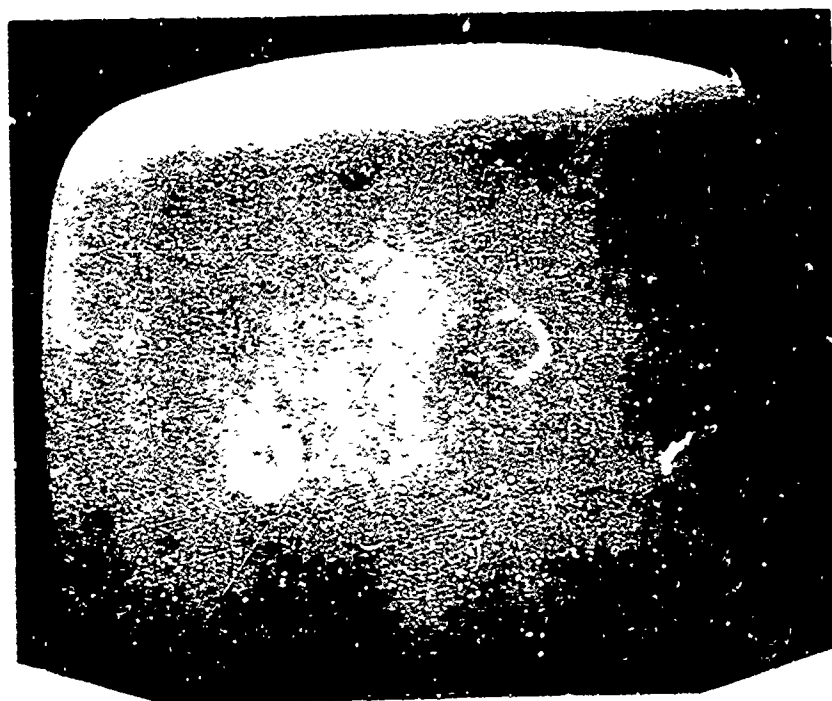

Fig. 5. TV view of sea urchins on canyon floor at 1350-ft depth.

the bottom just forward and to the left of the vehicle. The leading edge of the left vehicle track can just be seen in silhouette toward the upper right corner of the picture. Figure 5 shows a view of a pair of sea urchins alongside the vehicle.

A pair of acoustic transponders for navigation were dropped from the surface at locations near the two canyon walls approximately 2200 feet apart. RUM was positioned near a point midway between the transponders and off to one side of the transponder baseline. A navigation exercise was begun but the failure of a propulsion power control contactor forced an early termination of the operation. Upon the return of RUM on board ORB, a visual inspection revealed more carbon build-up, clinkers and burned contacts in several power control contactors. Since this was an indication that this kind of problem was not related strictly to one type of contactor, as had previously been assumed, but was present to a greater or lesser degree in all of the contactors used, a decision was made to terminate the operation and return RUM to the laboratory for a more serious study of the power control problem.

ORB was returned to its berth at "B" Street Pier by 0740 on April 8th.

#### Modification of Power Control Circuits

A considerable amount of experimental work with contactors in fluid, under pressure, has been done at the Naval Ship Research and Development Center at Annapolis. This work is reported in detail by Walter E. Pocock.<sup>2,3,4</sup> Effects of fluid viscosity, pressure, contact spacing, contact area, rate of contact opening break and the like are all treated and their relative contributions to sustained contact arc-over under pressure are discussed. The reporting of this work by NRDC was very timely and of considerable value to us. Our suspicions as to the cause of our trouble were confirmed and we were saved many costly hours of laboratory tests and analysis of test results. Simply stated, at high hydrostatic pressures the gas bubble which forms, between contacts with the arc accompanying contact break, does not blow out as at ambient pressure, but remains between contacts, a region of ionized gas to sustain arc-over. The sustained arc-over converts the surrounding oil to carbon, creating additional conductive paths between these and other nearby contacts or terminals.

The extent and character of the damage suffered is well illustrated by the extreme case shown in Figures 6 and 7. Figure 6 shows a motor reversing contactor just as it was removed from the



Fig. 6. Carbon formation extruding from top of ac power control contactor.

vehicle. Extensive carbon formation can be seen extruding out around the terminals at the top of the contact enclosure. Figure 7 shows the interior of the disassembled contactor with some of the contacts burned completely away.

Upon return to the laboratory two experimental approaches directed toward a solution of the contactor problem in the RUM vehicle were pursued.

#### Dynamic Squelch Test

The first, using solid state devices to provide a dynamic squelch across breaking contacts is shown in principle in the simplified schematics of Figure 8. The basic principle of operation is the same for the dc or ac controller. When switch S opens, the rapid voltage rise across it,  $(dv/dt)$ , is coupled into the base of transistor T through capacitor C in the case of the dc circuit, or into the gate of SCR<sub>1</sub> or SCR<sub>2</sub> in the case of the ac circuit. The transistor or SCR is driven "on" (into a conducting state) thereby momentarily maintaining near zero voltage across the opening contacts preventing the occurrence of an arc. In actual practice current limiting to base or gate should be provided. An rf filter to prevent line transients from firing the SCR circuit is also advisable. Both circuits were built and tested across contacts of standard contactors operating at full rated voltage and current in MIL-L-6081C turbine oil at 0 to 5000 psi. Unsquelched

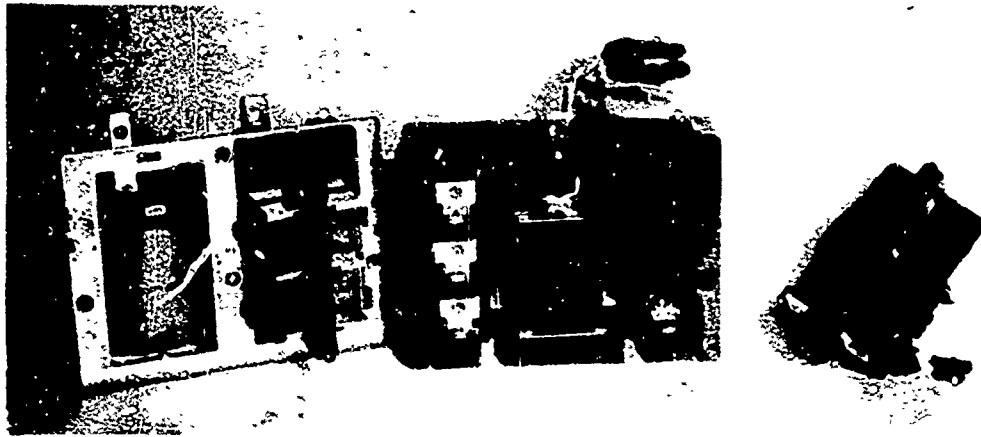

Fig. 7. Extensive carbon formation and severely burned contacts inside contactor.

contacts, in both ac and dc contactors, invariably failed in less than 10 cycles at any pressure above 500 psi while the squelched contacts operated perfectly at all pressures and showed only a very faint discoloration on the contact surfaces after several thousand cycles at maximum pressure of 5000 psi. Inductive as well as resistive loads were used in the tests.

In the photo of Figure 9, a test relay is shown. Both sets of contacts were wired to identical 4 A inductive loads. The power supply was 120 V 60 Hz. The test was conducted at 2000 psi. The unsquelched set of contacts on the right failed during the first 5 make-break cycles, so power was removed from this pair only. The other (SCR squelched) pair of contacts on the left are in perfect condition after more than 2000 make-break cycles under load.

Because of short on-times and extremely small duty cycles, transistors or SCR's may be used at nearly absolute maximum surge current ratings, without heat sinks.

This type of squelch was found to work very well on contacts of the simple single pole single throw configuration; however, its adaptation to bipolar switches and ac motor reversing controller circuits becomes complex and troublesome. When pairs of contacts are connected in series across the power source, as is the case in reversing controllers, the  $dv/dt$  generated by the breaking set of contacts tends to turn on the SCR or transistor across the open contacts as well as the one across the breaking contacts, thereby momentarily shorting out the power source. It is believed that this could be overcome through the use of auxiliary steering contacts, on the contactors, which disconnect the

squelch circuit from a pair of contacts when the opposite contacts are closed. This technique has not yet been tried however.

#### Solid State Control

The other approach, which was tried in the laboratory and later implemented throughout the RUM vehicle, was to eliminate all contacts which make or break under load and replace them altogether with solid state devices.

This implementation of solid state power controllers was the second attempt at substitution of solid state devices in place of contactors for power control on the RUM vehicle. In 1968 when work was first resumed on RUM, after an 8-year interruption, the design included SCR controllers for the majority of ac power switching. Severe problems with rf interference to the cable telemetry system, caused by the new SCR controllers, forced a return to buffering with relays and contactors for power control until suitable solid state switching circuits with acceptable interference levels could be developed. The currently used SCR controllers are isolated from the low signal level telemetry circuitry by reed switches. This isolation in company with zero axis crossing switch-design has reduced interference to a very acceptable level.

Power transistors are used in all dc power controllers and SCR's in all ac power control circuits.

The schematic of Figure 10 shows the type of transistor circuit used to provide fully reversible on-off control of a dc motor. The circuit is designed to limit the maximum current to the motor.

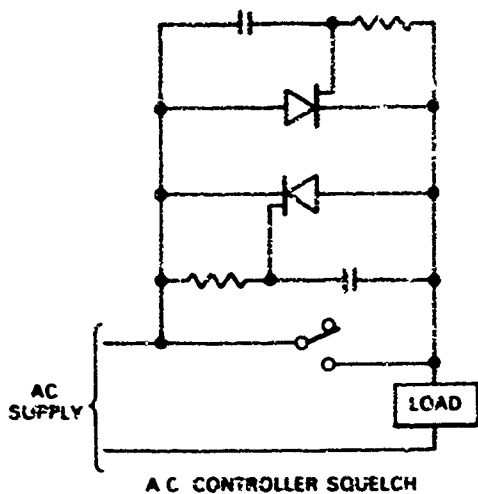
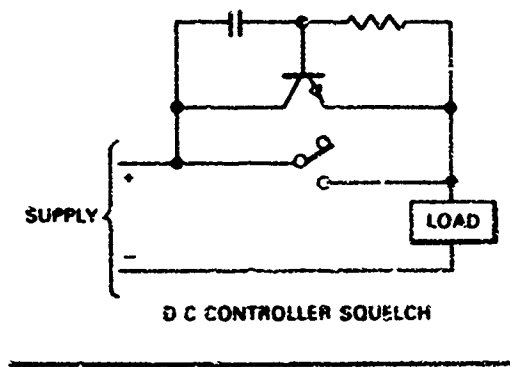

Fig. 8. Test circuits for squelch of contact arcing in power control contactors.

In Figure 11 the basic SCR power switch used to control ac power is shown. One phase-shift network is used to generate  $E \cos \phi$  for control of all SCR power switches in the vehicle. Reed relays are used to switch the low voltage low power  $E \cos \phi$  on and off for control of the SCR power switches; however, a bi-polar solid state switch could be used just as well. Figure 12 shows the configuration which uses 3 of these SCR power switches for full start-run and reverse control of an ac split phase induction motor.

These solid state power controllers, like all other electronic circuits in the RUM vehicle, are oil flooded and pressure compensated to work at full ambient pressure, to 5000 psi.



Fig. 9. Test relay contacts.

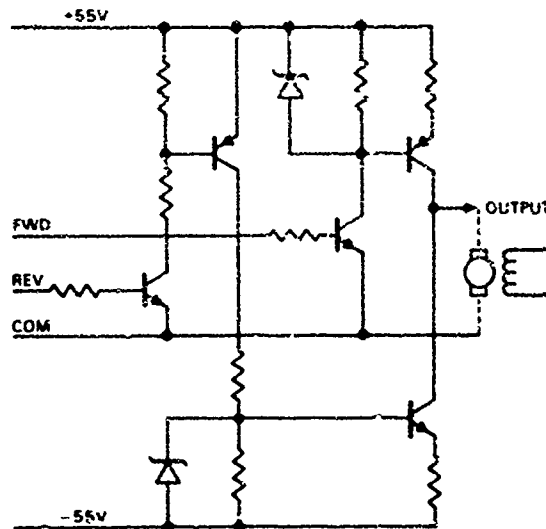

Fig. 10. Transistorized dc motor controller circuitry.

La Jolla Canyon Operations - July 29-August 7

After outfitting RUM with the new solid state controllers, RUM was once again loaded on board ORB. Following a week of dockside checkout and preparation for sea, ORB was taken under tow at 1100 on July 29th to make the transit to the previous operating area over the La Jolla Canyon near 117° 17.9'W, 32°53.58'N.

Upon arrival in the operating area, 3 anchors were placed on the bottom approximately one mile apart: one to the northwest, one to the north-

east and one nearly due south of the location chosen for the first lowering of RUM.

By 1430 on July 30th RUM was checked out as fully operational and pronounced ready for launch. The vehicle was launched and lowered to the sea floor at a depth of 1215 feet. During the lowering a very serious casualty occurred, the effects of which were to plague us for days to come. A 32-pin marine connector on the starboard TV camera flooded. This connector carried many low level signal and control leads as well as 120 V ac 60 Hz to power the focus motor. The ac power propagated across the

face of the connector and back through leads into several of the other subsystems, causing extensive damage in several areas of the vehicle. Many hours were consumed in repeated system check-outs and the tracing down, isolation and correction of the many isolated damages which had occurred.

By mid-afternoon on August 3rd, after two additional launches and lowerings to the canyon floor for tests, RUM was pronounced operational and ready for launch once again. Photographs were taken of the divers working during the vehicle launch.

In the launch procedure RUM is picked up a few inches from its resting place on ORB's well doors. Four steel cables snub RUM to prevent pendulum action. The doors are opened and RUM lowered to just below the lower edge of the open well doors. The snubbing cables are coupled to hydraulic rams which maintain constant tension during lowering. When lowering of RUM is stopped, with the vehicle just below the edge of the open well doors, divers enter the water. The snubbing cables are slacked off and the divers disconnect them (Figure 13). As soon as all four snubbers are disconnected, RUM is lowered 10 to 20 feet completely clear of the well doors, for greater diver safety at which point the divers perform additional chores in preparation for lowering of the vehicle to the bottom. In Figure 14 a diver unlocks the port TV camera boom. This lock prevents damage to the boom or camera assembly, from surge or wave action.

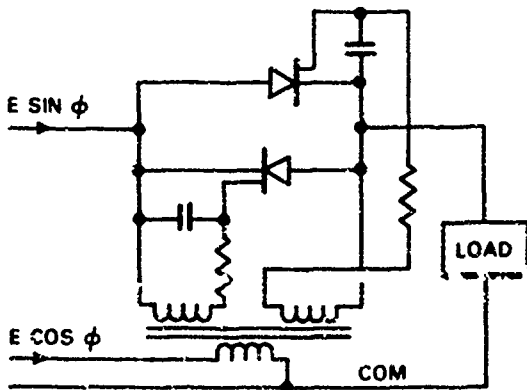

Fig. 11. Basic SCR power switch circuit.

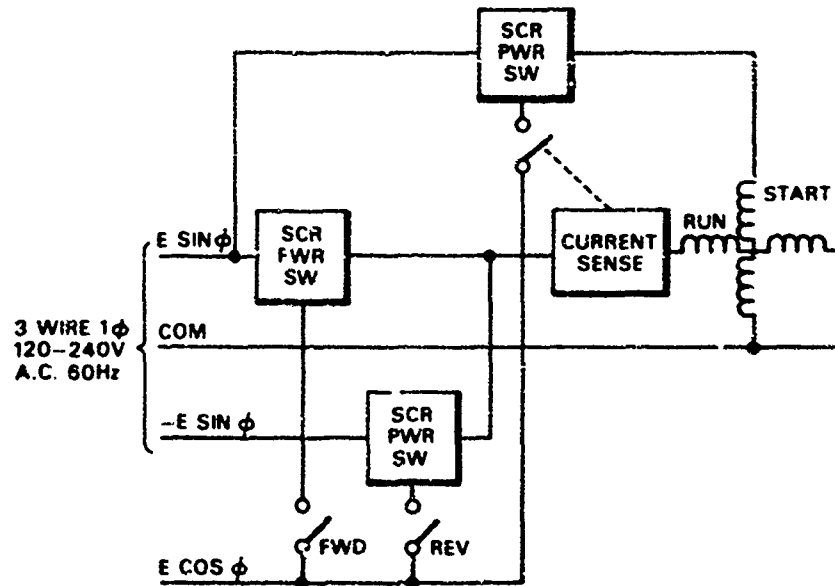

Fig. 12. Full start-stop-reverse ac induction motor controller using SCR power switches.

when passing through the surface zone into or out of the well. These procedures are reversed during recovery. Figure 15 shows a diver wiping the oil film from a TV camera lens.



Fig. 13. A diver disconnects snubbing cables.

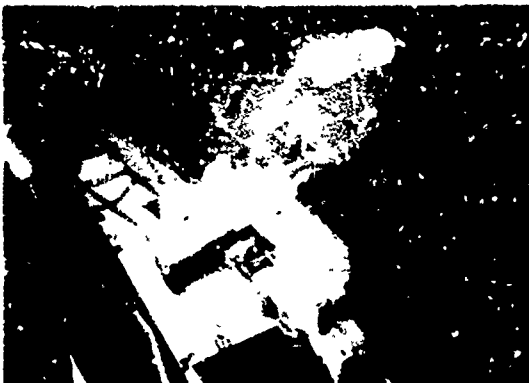

Fig. 14. Diver unlocks TV camera boom.



Fig. 15. Diver cleans TV camera lens following launch.

Operations involving maneuvering at various track pressures and a manipulation exercise wherein a sonar reflector was placed on the sea floor for later recovery were carried out. A problem with the pressure compensation system on the manipulator forced two additional recoveries of the vehicle for service, limiting total operation time on the bottom to 7-1/2 hours up until 1700 on August 4th.

By 1100 on August 5th RUM was again set on the canyon floor at 1220-foot depth, this time to carry out the longest and most successful operation to date. Twenty-nine and one-half hours of continuous operation were logged, during which a total distance of over 3400 feet was driven. A maximum down slope of 12° and an up slope of 20° were negotiated. Previous tracks left by the vehicle were located on sonar, approached, inspected, and crossed.

Trial maneuvers at various track pressures from 0.1 to 1.0 psi verified previous findings that optimum track pressure for this area ranged between 0.4 and 0.6 psi. Several estimates of draw bar pull capability of the vehicle based on wire angle and wire tension (horizontal force component) ranged from 800 to 1200 psi. Silt accumulation completely clogged the cleats on the vehicle tracks from time to time (see Figures 16 and 17). When difficulty in maneuvering was experienced which did not appear related to terrain, wire angle or track pressure, the vehicle was picked up a few feet off the bottom and the tracks run at full speed forward and reverse to wash the accumulated silt from the tracks. Plans call for the installation of a track wash pump and nozzle system on the vehicle for the determination of the feasibility of cleaning the tracks as the vehicle is driven over the bottom.



Fig. 16. Silt accumulation in vehicle tracks.

An acoustic transponder planted during the previous operations in April, on the floor of the canyon near the north wall at 1330-foot depth, answered-up at a range of 2320 feet when first interrogated. It was localized, closed to within sonar



Fig. 17. Silt accumulation in vehicle tracks.

range and recovered by the manipulator in a series of maneuvers without benefit of other transponders for directional sense.

The approximate track traversed by the RUM vehicle in closing the transponder is shown in Figure 18.

Operations with RUM were terminated at 1610 on August 6th following recovery of the transponder.

ORB returned to "B" Station Pier at 0700 on August 7th.

#### Conclusion

Although constant upgrading, de-bugging and improvement of the ORI-RUM Sea Floor Work System continues, this series of operations completes the major test evaluation and de-bug phase of the RUM II program. A great deal of operational experience has been gained. Useful work tasks have been

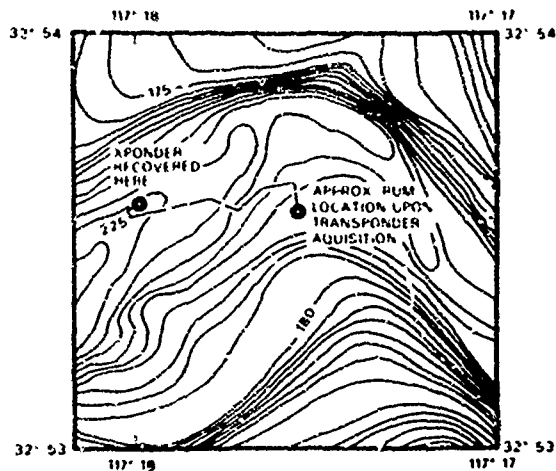

Fig. 18. RUM vehicle traverse over floor of La Jolla Canyon.

performed. Capability for maneuvering in the soft, low-strength, clayey-silt has been proven. Much has been learned about the visibility problem, turbidity clouds and how to cope with them. Fluid immersed solid state circuitry operating at ambient pressure is an operational reality.

The next phase in the RUM program is the design and development of a suite of instruments, for use on the RUM vehicle and to be handled by the manipulator, for conducting *in situ* soil mechanics measurements and trafficability studies on the sea floor in water depths to 6000 feet.

#### REFERENCES

1. Marine Physical Laboratory Sea Floor Technology Report #1. RUM Operations - January 1970.
2. Pocock, W. E., "Deep Ocean Technology Program, Electrical Protective and Switching Devices in Fluid Pressure Ambients, Part I: Mechanical Switching Devices," NAVSHIP-RANDLAB, Annapolis Rept. ELEC LAB 23/69, May 1969.
3. Pocock, W. E., "Deep Ocean Technology Program, Electrical Mechanical Switching Devices," NAVSHIP-RANDLAB, Annapolis Rept. 6, 8/70, February 1970.
4. Pocock, W. E., "Deep Ocean Technology Program, Mechanical Devices for Circuit Interruption in Fluid Pressure Ambients," NAVSHIP-RANDLAB, Annapolis Rept. 6, 62/70, October 1970.

(ORB continued from front cover)

In addition to laboratory work spaces and machinery space, ORB is equipped with complete living facilities for 12 people including 4 crew members.

The "ORB" concept originated with Dr. Victor C. Anderson, Associate Director of the Marine Physical Laboratory. Preliminary design was carried out by Dr. Anderson, Associate Engineer P. N. Stever and Marine Coordinator E. D. Brown. The firm of L. R. Gloster and Associates of Seattle provided the Naval Architect services for final design. Construction was accomplished by California Steel Fabricating and Welding Engineering Corporation of San Diego under the sponsorship of the Office of Naval Research. The design of the buoy ORB emphasized simplicity and economy of construction and operation, functional utility, and minimum maintenance. Design, construction and outfitting were carried out at a total cost of \$278,000.00.

(RUM continued from front cover)

The portside TV camera is boom-mounted with the pivot point near midway on the port side. The camera stows forward for driving but may be swung in a wide arc away from the side of the vehicle and around to the rear for close-in viewing of the manipulation areas. The starboard camera is mounted on a dolly which may be positioned anywhere from forward for driving to the rear for manipulator viewing.

Two telemetry systems are used for control and instrumentation, one, a time multiplex system providing 64 channels each way, up and down the cable, the other an amplitude modulated carrier system with four carriers transmitted down the cable and eight carriers returned.

During operations the vehicle is launched through the well on ORB, lowered to the sea floor and the cable tensioning system set for a reasonable tension from 5,000 to 10,000 pounds depending on bottom conditions and depth of water. Once RUM is on the bottom it serves as a more than adequate anchor for ORB. As RUM drives across the sea floor it tows ORB across the surface above it at speeds up to 1 knot. The cable constant tensioning system on ORB automatically pays in or pays out cable as needed.

Best Available Copy

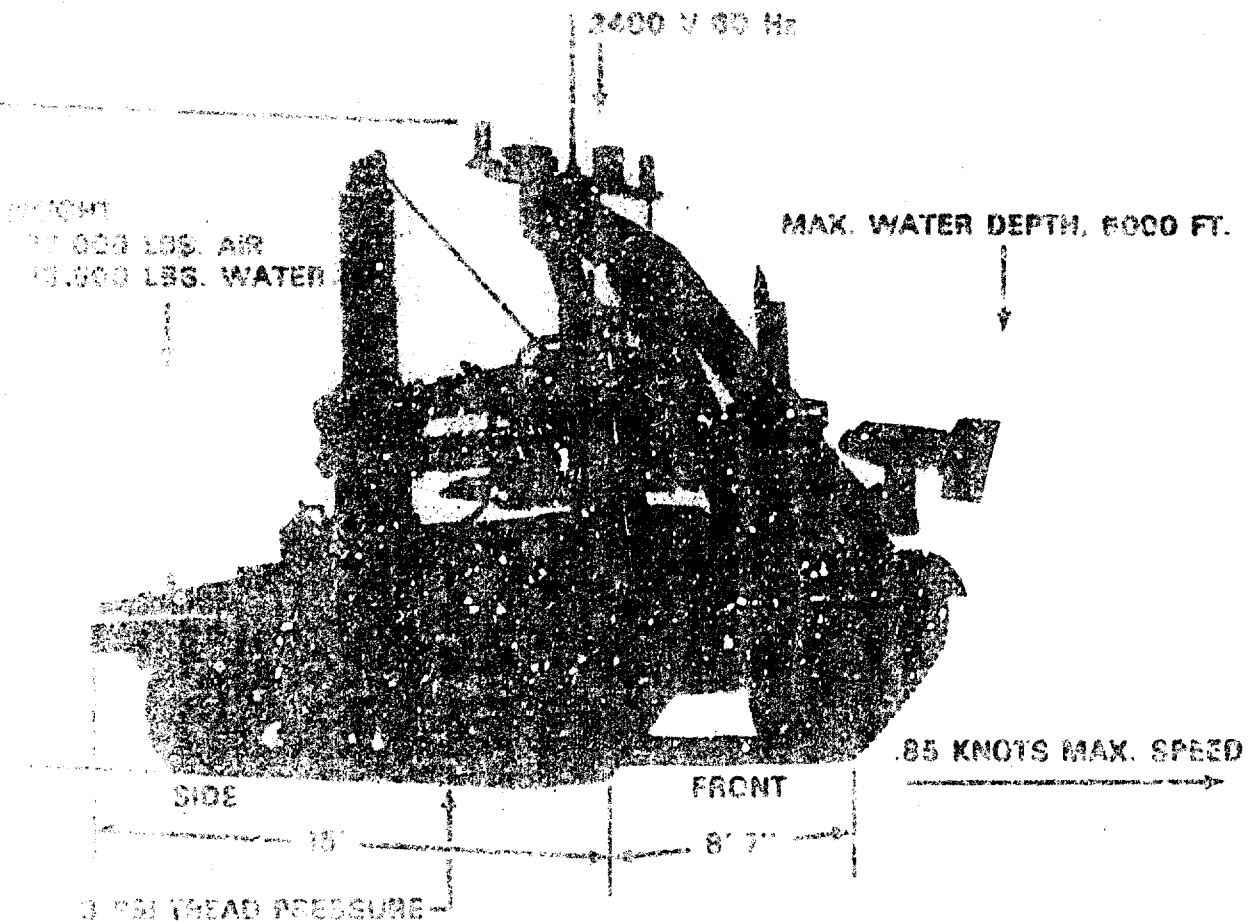

Best Available Copy