

SAM-TR-71-49

AD 740866

DEVELOPMENT OF A SOLID-STATE IMPEDANCE PLETHYSMOGRAPH FOR RESEARCH IN A SPACE ENVIRONMENT

JOHN W. YATES, Captain, USAF

Reproduced by
NATIONAL TECHNICAL
INFORMATION SERVICE
Springfield Va 22151

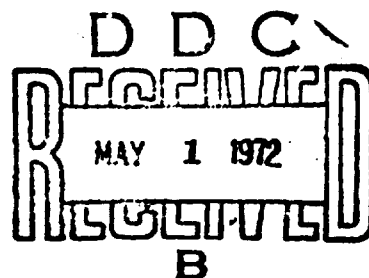

Best Available Copy

USAF School of Aerospace Medicine
Aerospace Medical Division (AFSC)
Brooks Air Force Base, Texas

December 1971

Approved for public release; distribution unlimited.

33
R

Unclassified

Security Classification

DOCUMENT CONTROL DATA - R & D		
<i>(Security classification of title, body of abstract and indexing annotation must be entered when the overall report is classified)</i>		
1. ORIGINATING ACTIVITY (Corporate author) USAF School of Aerospace Medicine Aerospace Medical Division (AFSC) Brooks AFB, Texas 78235		2a. REPORT SECURITY CLASSIFICATION Unclassified
		2b. GROUP
3. REPORT TITLE DEVELOPMENT OF A SOLID-STATE IMPEDANCE PLETHYSMOGRAPH FOR RESEARCH IN A SPACE ENVIRONMENT		
4. DESCRIPTIVE NOTES (Type of report and inclusive dates) April - July 1970		
5. AUTHOR(S) (First name, middle initial, last name) John W. Yates, Captain, USAF		
6. REPORT DATE December 1971	7a. TOTAL NO OF PAGES 25	7b. NO OF REFS 18
8a. CONTRACT OR GRANT NO	9a. ORIGINATOR'S REPORT NUMBER(S) SAM-TR-71-49	
b. PROJECT NO 6320	9b. OTHER REPORT NO(S) (Any other numbers that may be assigned this report)	
c. Task No. 632001		
d.		
10. DISTRIBUTION STATEMENT Approved for public release; distribution unlimited.		
11. SUPPLEMENTARY NOTES	12. SPONSORING MILITARY ACTIVITY USAF School of Aerospace Medicine Aerospace Medical Division (AFSC) Brooks Air Force Base, Texas 78235	
13. ABSTRACT A new solid-state impedance plethysmograph utilizing a constant current source was designed, built, and tested. This report presents the design philosophy, the circuitry, the final configuration of the device, and the techniques for its proper alignment. The circuit detects a 1% impedance change centered on basal body impedance levels between 100 ohms and 15 kilohms. Although normally operated at 100 kHz, the circuit will operate at various frequencies, and it will accommodate either the bipolar or tetrapolar electrode configuration. Circuit performance was confirmed by taking thoracic impedance measurements on a human subject.		

DD FORM 1 NOV 68 1473

Unclassified

Security Classification

14 KEY WORDS	LINK A		LINK B		LINK C	
	ROLE	WT	ROLE	WT	ROLE	WT
Bioinstrumentation Respiration measurement Impedance plethysmograph Impedance pneumograph Plethysmography						

ERRATA

SAM-TR-71-49, "Development of a Solid-State Impedance Plethysmograph for Research in a Space Environment," by John W. Yates, December 1971. USAF School of Aerospace Medicine, Aerospace Medical Division (AFSC), Brooks Air Force Base, Tex.

P. 9, table II, col. 1, line 4 -- Should be R₅ and R₂₀

P. 12, last paragraph, line 4 -- Should be R₁₆ and R₁₈

P. 12, last paragraph, line 6 -- R₁₇ + R₁₈ should be R₁₈ + R₁₉

WRITE SECTION		<input checked="" type="checkbox"/>
DIFF SECTION		<input type="checkbox"/>
INDEXED		<input type="checkbox"/>
JOB		
SECTION/AVAILABILITY CODES		
DIST.	AVAIL.	OR/OR SPECIAL
A		

FOREWORD

This work was done in the Biomedical Engineering Branch, Support Services Division, under task No. 632001. The work was accomplished in the period from April to July 1970. The paper was submitted for publication on 15 October 1971.

The author wishes to thank Dr. L. A. Geddes and Dr. H. S. Lipscomb of the Journal of the Association for the Advancement of Medical Instrumentation for their permission to reprint figures 1 through 4 in this paper.

This report has been reviewed and is approved.

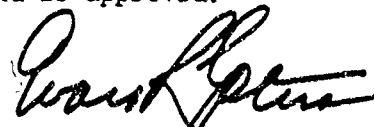

EVAN R. GOLTRA, Colonel, USAF, MC
Commander

ABSTRACT

A new solid-state impedance plethysmograph utilizing a constant current source was designed, built, and tested. This report presents the design philosophy, the circuitry, the final configuration of the device, and the technics for its proper alignment.

The circuit detects a 1% impedance change centered on basal body impedance levels between 100 ohms and 15 kilohms. Although normally operated at 100 kHz, the circuit will operate at various frequencies, and it will accommodate either the bipolar or tetrapolar electrode configuration. Circuit performance was confirmed by taking thoracic impedance measurements on a human subject.

DEVELOPMENT OF A SOLID-STATE IMPEDANCE PLETHYSMOGRAPH FOR RESEARCH IN A SPACE ENVIRONMENT

I. INTRODUCTION

The goal of this project was to design a solid-state impedance plethysmograph to investigate the feasibility of monitoring tidal volume in a space environment. The two basic impedance measuring systems used today are the bridge circuit (10, 11) and the constant current circuit (2, 6). The bridge circuit has two limitations that make it impractical for the dynamic requirements of a space environment: (1) constant balancing is required to keep the system operating around its null position, and (2) the bridge circuit becomes nonlinear as the distance from the null point increases. Both limitations become very serious because of the large impedance changes due to changes in body position.

The constant current source has basic features that make it ideal for body impedance measurements. First, the relationship between voltage and resistance is linear for as long as the current remains constant. Second, this linear relationship exists over a large, measurable impedance range. Another important feature of the constant current system is that impedance changes related to pulmonary function can be measured independently of the basal body impedance.

In the past, two different constant current systems have been used for many body impedance studies. The first, employed by many investigators (13), consisted of a constant current source as the exciter and a bridge circuit as the monitor. Although a constant current source is used, the basic problems of the bridge circuit are still encountered in this arrangement. In the second system, used by Geddes et al. (7), a 100-kilohm resistor is placed in series with the signal source. This resistance, which is very large compared with body impedance, results in a nearly constant current through the body. A very small change in current through the body does occur when the basal body impedance changes. In many cases this increment is greater than the impedance alteration due to respiration. It then becomes impossible to differentiate between the two. However, modern operational amplifier technology makes it possible to approximate more closely a constant current source than previous

designs permitted. In this study a constant current source plethysmograph, using operational amplifiers, has been designed and constructed.

II. DESIGN PROCEDURES

Two major characteristics required consideration in designing this impedance plethysmograph: (1) safety features - for its use in monitoring human subjects, and (2) design flexibility - for its use as a research instrument. Table I lists both safety and design characteristics.

TABLE I

Impedance plethysmograph safety and design characteristics

Safety

Subject cannot be electrically grounded by the device.

Constant current source has an amplitude below the sensation threshold at the usual 100-kHz operating frequency.

Devices are included to eliminate the shock hazard if malfunction occurs.

Design

Stable constant current source.

Internal 100-kHz oscillator.

May be connected to a variable frequency generator which permits observations over a wide range of frequency.

Operates over a wide impedance range.

Capable of measuring a 1% impedance change.

Basal body impedance and impedance changes resulting from minute-to-minute respiration are measured.

Operates with bipolar or tetrapolar electrodes.

Safety features

The hazards associated with supplying a current to the body represent an important design consideration. Therefore, the effects of current and voltage on the body are a prime concern in this study. Several investigators have studied the effects of electrical current on the body (5, 8, 17). Geddes and Baker (8) reported that as the frequency of the stimulating current increases, the current required to produce threshold sensation also increases. Figure 1 shows the relationship between threshold sensation and frequency for various electrode positions. This graph shows that a low stimulating current at a high frequency eliminates the possibility of discomfort.

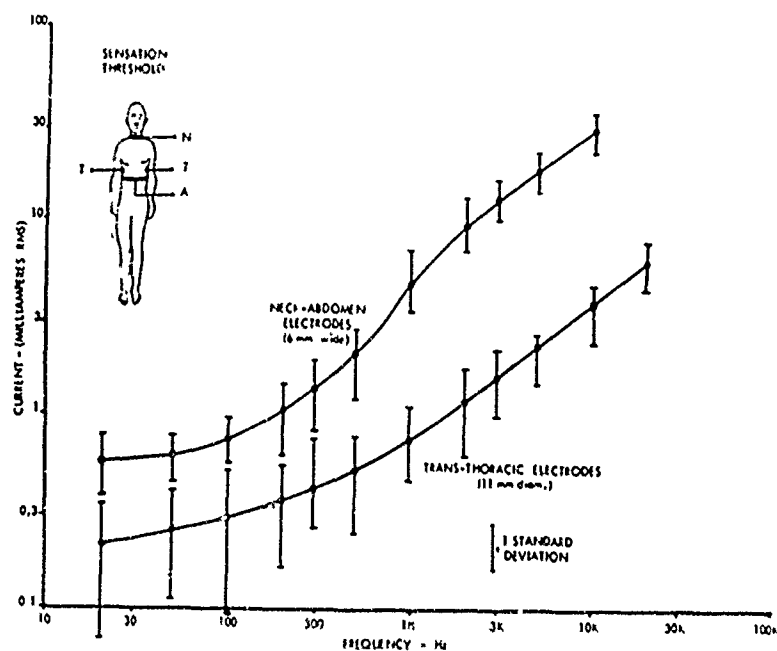

FIGURE 1

Current needed to produce threshold sensation as a function of frequency - different electrode positions. (Reprinted by permission of author.)

The effects on the internal structures of the body have to be considered when currents greater than those needed for sensation are used. In particular, structures such as the vagus and phrenic nerves and the ventricular fibers require the most attention. Stimulation of vagus and phrenic nerves can cause heart stoppage or prevent respiration.

Stimulation of the ventricular fibers can cause ventricular fibrillation, which could result in permanent damage to the nervous system.

Figures 2 and 3 show the current needed to produce ventricular fibrillation (in dogs) as a function of frequency. Figure 2 shows this current relationship for a transthoracic electrode system, and figure 3 shows the same relationship using the neck-abdomen electrode system.

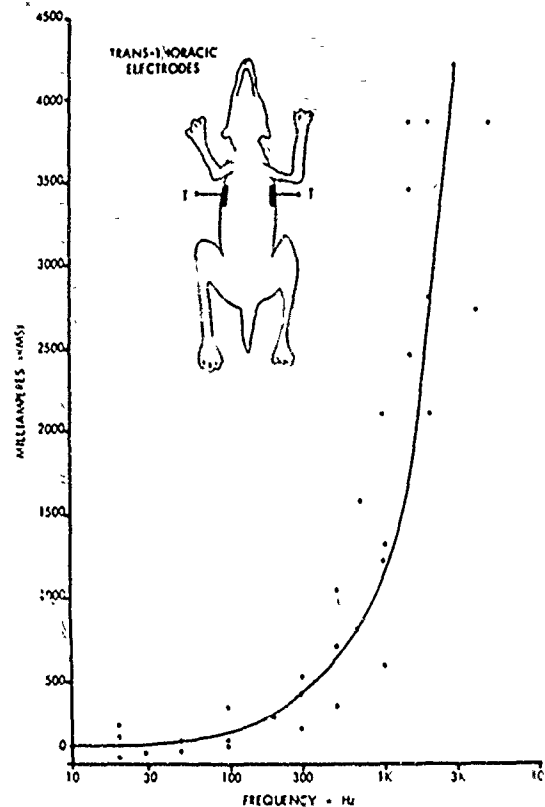

FIGURE 2

Current needed to produce ventricular fibrillation as a function of frequency - transthoracic electrode placement. (Reprinted by permission of author.)

Extrapolation of the results in figures 2 and 3 shows that at 10 kHz a neck-abdomen current of 4380 ma. or a transthoracic current of 8800 ma. is needed to produce ventricular fibrillation in dogs.

These figures indicate that as frequency increases, more current is required to cause ventricular fibrillation. Therefore, 5 ma. at 100 kHz was established for normal operation of this system. From figure 1, this point is below that needed to produce sensation.

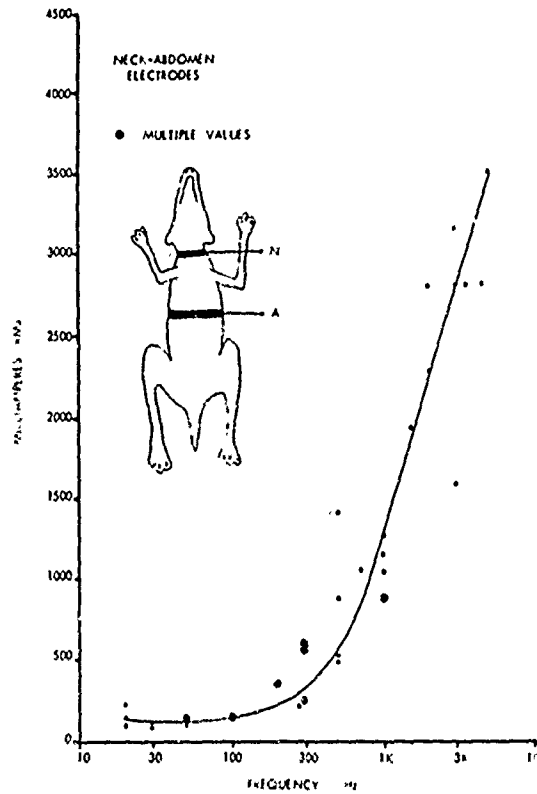

FIGURE 3

Current needed to produce ventricular fibrillation as a function of frequency - neck-abdomen electrode placement. (Reprinted by permission of author.)

Geddes and Baker (8) extended their investigation to include the effect of body weight on the value of current needed to produce ventricular fibrillation in animals. The results of this study, indicated in figure 4

(lower half), show that more thoracic current is needed to produce ventricular fibrillation as body weight increases. By assuming that this relationship is independent of frequency, additional graphs can be drawn for various frequencies. Figure 4 (upper half) shows the body weight-current relationship at 10 kHz for both the transthoracic and neck-abdomen electrode configurations. These additional curves show that the 10-kHz current required to produce ventricular fibrillation for an animal with a body weight of 73 kg. (160 lbs.) is about 4000 ma. greater than that found for animals with body weights of 10 kg., under the same conditions.

Although there may not be a direct correlation between man and animals, it is probably safe to assume that the results would be similar. These current values are far above the operating current of this system.

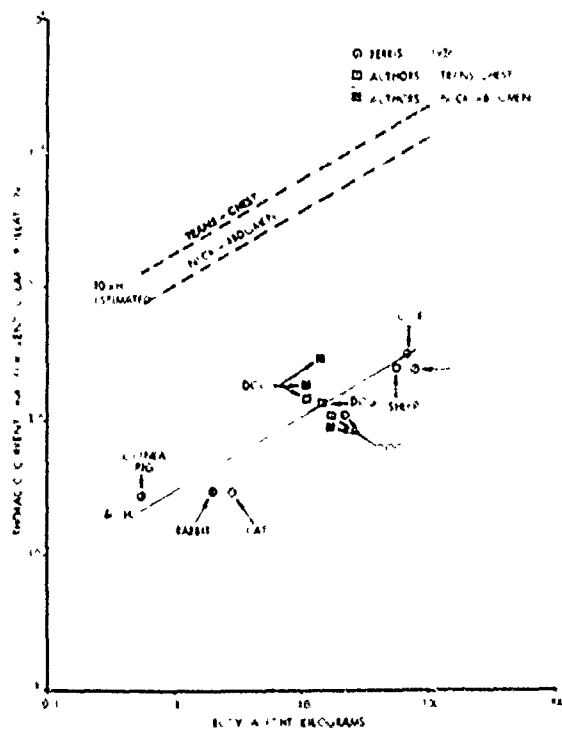

FIGURE 4

Current needed to produce ventricular fibrillation in animals of large body weight. (Reprinted by permission of author.)

Two 6.8-v. zener diodes (D_1 and D_2) are included in the feedback loop of the constant current source for subject protection. If either of the first two amplifiers saturate, only 6.8 v. appear across the subject, with a maximum current of 0.34 ma. through the subject.

Subject isolation from ground is another safety feature of this device since there is no common point in the chest area that could attract current from outside sources.

Design features

Figure 5 shows a block diagram of the impedance plethysmograph. A 100-kHz oscillator is the signal source of this circuit.

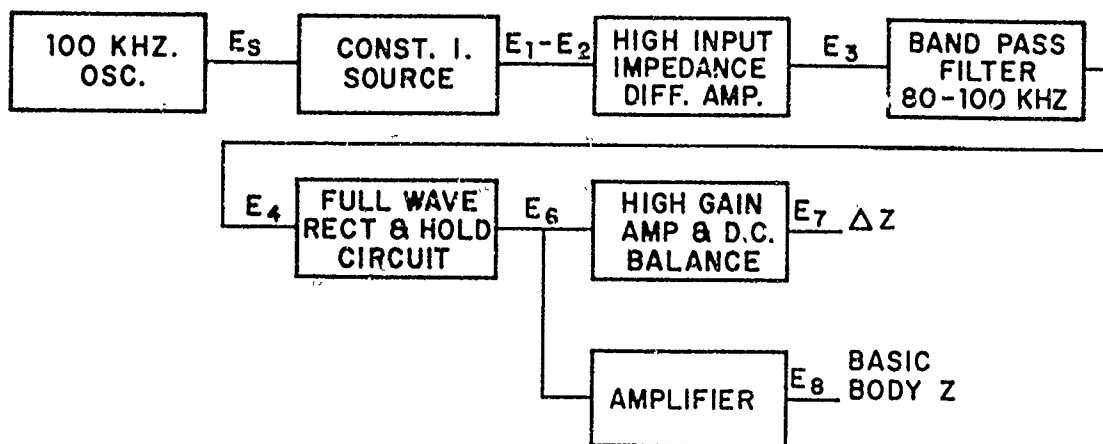

FIGURE 5

Impedance plethysmograph block diagram.

This 100-kHz voltage (E_s) drives the constant current source, resulting in a 100-kHz constant current that can be applied to the body. A high input impedance differential amplifier converts the change in voltage (E_1-E_2) across the body to a single-ended signal (E_3) which is passed through a commercially made band pass filter. This filter eliminates extraneous signals not related to the 100-kHz carrier. The filtered signal is converted to d. c. (E_6), using the full-wave rectifier and hold circuit. The d. c. voltage serves as an input signal to a high-gain amplifier with d. c. balance and to an additional low-gain amplifier. The former amplifies the very small voltages due to minute impedance changes, producing a usable signal proportional to the thoracic volume change. The latter amplifies the signal proportional to the basic body impedance.

The complete circuit, described in the following sections, is shown in figure 6. Table II shows the component values of the impedance plethysmograph.

Oscillator circuit (3)

The oscillator used in this circuit is a double integrator with regenerative feedback. The frequency of oscillation is determined by

$$f = \frac{1}{2\pi R_1 C_2}$$

For best results, the potentiometer R_4 should be adjusted to the point at which the circuit starts to oscillate. At this setting the peak-to-peak output voltage (E_5) is approximately 2.75 v.

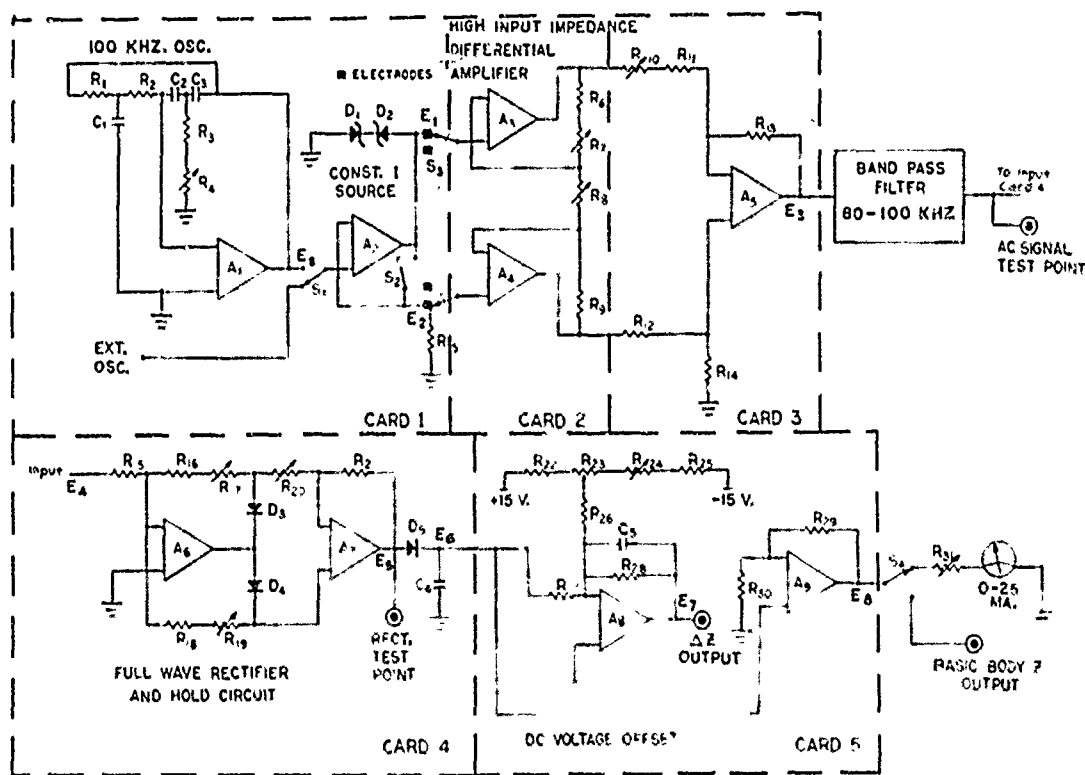

FIGURE 6

Impedance plethysmograph circuit diagram.

TABLE II

Component values of impedance plethysmograph
(R in ohms; C in microfarads)

R ₁ , R ₂	453	C ₁	.0066
R ₃	100	C ₂ , C ₃	.0033
R ₄	200	C ₄	.1
R ₅	20K	C ₅	.004
R ₆ , R ₈ , R ₉ , R ₁₅ , R ₂₁	10K		
R ₇ , R ₂₃ , R ₃₁	500	D ₁ , D ₂	1N3016
R ₁₀ , R ₂₂ , R ₂₅ , R ₂₆ , R ₂₇	1K	D ₃ , D ₄	1N3484
R ₁₁ , R ₁₂ , R ₁₃ , R ₁₄	4.7K	D ₅	1N539
R ₁₆ , R ₁₈	9.1K		
R ₁₇ , R ₁₉	2K	A ₁	5010
R ₂₄	10	A ₂ to A ₉	3307
R ₂₈	1M		
R ₂₉ , R ₃₀	100K		

Constant current source (16)

Ohm's Law, $E=IZ$, will demonstrate that a constant current source can be utilized to measure thoracic impedance. Since the measured voltage (E) is a function of the current (I) through the body and the impedance (Z) across the body, a change in either of these parameters will cause a voltage change. Therefore, by keeping the current constant, the voltage change is directly proportional to an impedance change.

The inherent properties of an operational amplifier, namely, an effective zero voltage between amplifier inputs and zero input current to both amplifier inputs, form the basis for the constant current source. With only a minute current flowing into the upper (negative) input terminal, the current through R_5 is equal to the current through the body. Since the voltage between amplifier inputs is approximately zero, the voltage across R_5 is equal to the oscillator voltage. Therefore, the current through the body is determined by

$$I_{\text{Body}} = \frac{E_s}{R_5}$$

The ability of the oscillator to maintain a constant voltage output is necessary for the proper operation of the current source. Since no current flows into the positive (lower) input terminal of the constant current source, the oscillator is not loaded and produces a constant voltage regardless of body impedance.

The constant current source in this impedance plethysmograph is basically an operational amplifier connected in the noninverting configuration. The output voltage (E_1) is given by

$$E_1 = E_S \frac{R_L + R_5}{R_5}$$

Since voltage E_2 equals oscillator voltage E_S , the voltage across the body ($E_1 - E_2$) is given by

$$E_1 - E_2 = \frac{R_L}{R_5} E_S$$

This equation shows that the voltage measured across the body is linearly related to the impedance of the body.

This linear relationship is restricted by the electrical specifications of the operational amplifier. Since the specifications set the maximum allowable output voltage at approximately ± 10 v., the maximum basal body impedance is limited to approximately 36.5 kilohms to prevent amplifier saturation. The minimum impedance required for linear operation is determined by the common-mode rejection of the amplifier, the input voltage offset, and the input current bias. A value of approximately 100 ohms has been measured as the lower limit of acceptable basal body impedance. A previous study (18) has shown that the actual basal body impedance is well within the limits of this constant current source.

A test of the constant current source established a constant current of 0.125 ma, $\pm 10\%$ for test impedances varying from 40 ohms to 75 kilohms. This variance in the current occurred only at the extremes of the impedance range.

A short circuit (S_2) is connected across the load to protect the constant current amplifier stages when the circuit is not connected to a subject. This prevents any of the amplifiers from saturating when there is an open circuit in the feedback loop of the constant current source (i. e., when no measurements are being taken).

High input impedance differential amplifier (16)

In order for the voltage across the body ($E_1 - E_2$) to be a true measurement of body impedance, there can be no loading by the recording amplifier. In order to prevent loading, ultrahigh input impedance is needed in the recording amplifier. In addition, a differential input amplifier is needed because the subject is not grounded. Two Burr-Brown 3307 operational amplifiers, connected in the noninverting configuration with cross coupling, solves both these problems (16). The typical input impedance of this high-impedance differential amplifier is 10^{11} ohms at each input. The gain of this amplifier is given by

$$A = 1 + \frac{R_6 + R_7}{R_8} + \frac{R_9}{R_8}$$

The cross coupling in this configuration considerably improves the common-mode response of the amplifier because the differential voltage ($E_1 - E_2$) is only amplified by a factor of 1.

In order to optimize the common-mode rejection, it is necessary to match the gain of the amplifiers as close as possible. Potentiometer R_7 is used to balance the gain of these two amplifiers. This resistor also compensates for differences in the operational amplifiers.

An additional reason for requiring high impedance at the amplifier input terminals is the impedance change at the electrode-skin interface of the recording electrodes. These changes, ranging from a few ohms (due to drying of the electrode paste) to several thousand ohms (due to a direct pressure caused by tape or clothing), are represented as resistances in series with the input impedance of the amplifier. The high input impedance of the amplifier (10^{11} ohms) will completely mask the typical impedance changes at the electrode-skin interface. However, it will be shown later that even this high input impedance will not eliminate the effect of large pressure variations, such as those produced by tapping on the electrode.

Amplifier A_5 converts the differential signal to a single-ended signal. The following equation shows the gain for this stage, provided that $R_{13} = R_{14}$ and $R_{12} = R_{10} + R_{11}$.

$$A = -\frac{R_{13}}{R_{12}}$$

Potentiometer R_{10} balances the gain at each input of the amplifier. This resistor allows the final adjustment to insure a properly balanced signal.

Band pass filter

The band pass filter for this system was a Dytronics model 723, which eliminates any stray signals other than the 100-kHz signal necessary for the impedance measurement. Tests using this filter have shown that it is not required with the 2-electrode system, but it is necessary to eliminate ECG effects with the 4-electrode system.

Full-wave rectifier and hold circuit (12)

The full-wave rectifier and hold circuit converts the 100-kHz signal to a d. c. voltage proportional to the impedance of the body. With this transformation, strip chart recorders can be used for the measurements.

This full-wave rectifier has many advantages over the standard rectifier circuit (12). These are: (1) The input voltage (E_4) drives only one amplifier instead of two in parallel; (2) negative current is not eliminated by an offset current; thus the amplifier does not have to supply as much current; and (3) more than one signal can be connected to the rectifier if necessary.

The operation of this circuit can be determined by studying the effects of a positive and negative input signal (E_4). As E_4 becomes positive, the signal through A_6 becomes negative and diode D_3 conducts. This voltage is then amplified and inverted through A_7 . Thus, for a positive signal, two inverting amplifiers are connected in series; the gain is given as

$$\frac{E_5}{E_4} = \left[\frac{R_{16} + R_{17}}{R_{15}} \right] \left[\frac{R_{21}}{R_{20}} \right]$$

For negative input voltages the signal is also inverted through A_6 . Diode D_4 conducts in this situation. Thus, there is a feedback loop from the output of each amplifier to the negative input terminal of amplifier A_6 . The gain for a negative signal is given as

$$\frac{E_5}{E_4} = \frac{(R_{18} + R_{19})(R_{16} + R_{17} + R_{20} + R_{21})}{R_{15}(R_{18} + R_{19} + R_{16} + R_{17} + R_{20})}$$

Although in theory perfect unity gain can be achieved by using identical resistors, in reality this does not occur because of differences in the amplifiers and individual components. Potentiometers R_{17} and R_{19} are used to correct for component differences in R_{16} and R_{17} respectively and for the difference in gain for positive and negative signals in the first stage of the rectifier circuit. As $R_{16} + R_{17}$ does not equal $R_{17} + R_{18}$ upon adjusting the first stage, a second potentiometer (R_{20}) is used to compensate for this difference and to insure a balanced, rectified output with unity gain.

The holding portion of this circuit consists of capacitor C_4 and the input impedance of the next stage. The time constant is sufficiently long to permit a ripple of less than 20%. Diode D_5 prevents the capacitor from discharging into amplifier A_7 .

Voltage offset

The voltage E_6 represents two signals. One signal is proportional to the basal body impedance, and the other to the changes in thoracic impedance. These thoracic impedance changes are very small, and high-gain amplifier A_8 (gain 1000) is used to amplify them. However, that portion of the d. c. voltage (E_6) representing the basal body impedance is also amplified, and this portion of the signal is large enough to cause saturation in amplifier A_8 .

In order to eliminate this problem, an offset voltage controlled by resistors R_{22} to R_{26} inclusive is used in this device. The coarse-adjustment potentiometer R_{23} and the fine-adjustment potentiometer R_{24} are used to set the output voltage at zero volts d. c. With the offset voltage, the small changes of impedance due to respiratory motion can be measured. A typical output would be a 4-v. change for a 10-ohm change. The capacitor C_5 in the feedback loop eliminates any stray high-frequency components over 50 Hz.

It is also desirable to measure the basal body impedance of the subject. For this purpose, amplifier A_9 and the milliammeter are included in the design. The d. c. voltage (E_6) is amplified by a factor of 2 in the noninverting amplifier (A_9) before termination to a milliammeter or a strip chart recorder. Since 1700 ohms is the midrange of expected impedance for a transthoracic measurement, this value is set midscale on the meter. Lower and upper scale impedance values of 1100 and 2300 ohms are indicated on the meter. The entire impedance measuring range of the meter is controlled by potentiometer R_{31} . This produces various impedance measuring ranges between 40 ohms and 15 kilohms.

Test points

In order to insure proper operation and alignment of the impedance plethysmograph, two test points are included in the design. The first is the a. c. signal test point. Because of different attenuation levels in off-the-shelf filters, this point is placed at the filter output. Tests of the circuit have indicated that a 2-v. peak-to-peak voltage at this point (E_4) yields an output range high enough to permit transthoracic impedance measurements on most subjects. This 2-v. value is adjusted by potentiometer R_8 .

The meter for this design is calibrated so that the readable range is 1.1 to 2.3 kilohms. If a different range is desired, the meter would have to be replaced. Figure 7 shows the meter used in this circuit. Figure 8 shows typical signals from the filter stage to the meter for body impedances of 1.1, 1.7, and 2.3 kilohms (rows A, B, and C respectively). It should be noted that although the ripple appears on the oscilloscope, it does not appear on strip chart records or the meter because of the low-frequency response associated with these devices.

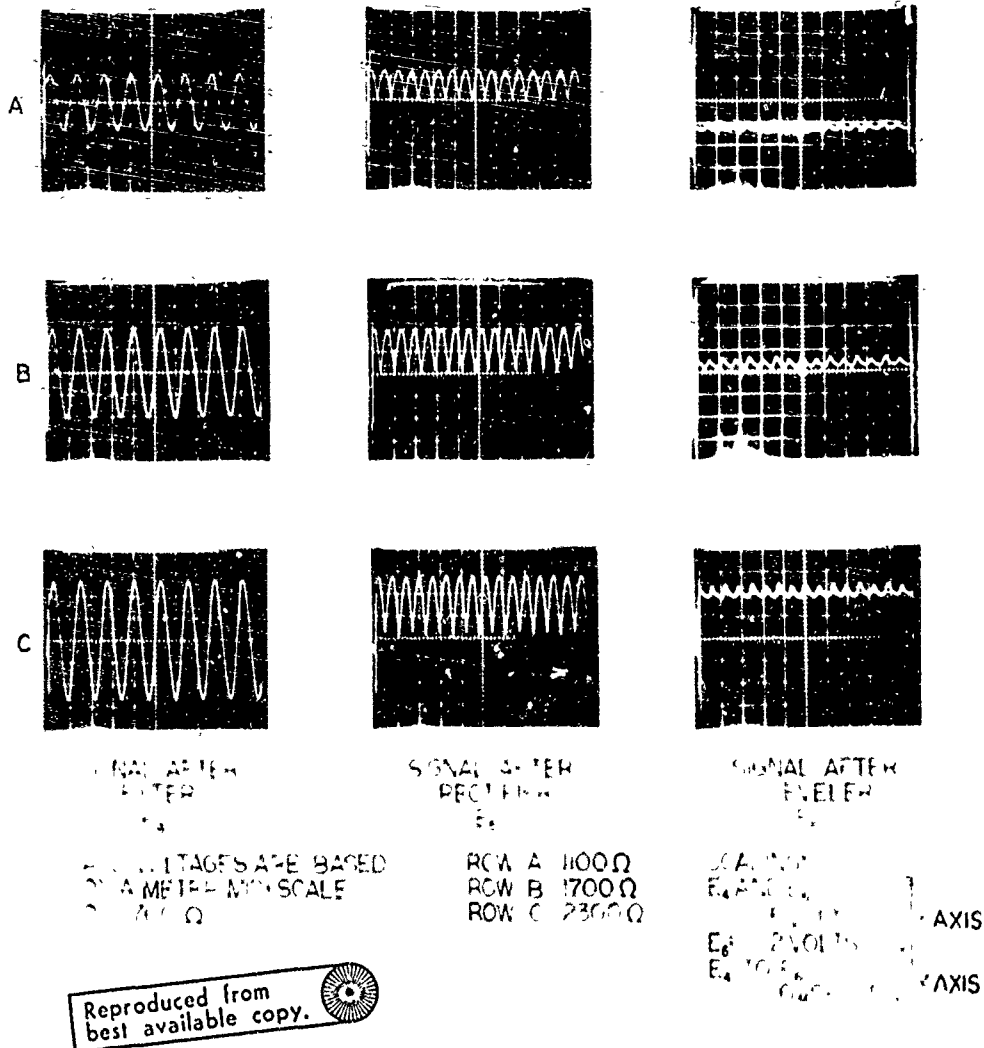

FIGURE 8

Voltage comparison for three different impedance levels.

Figure 9 shows the change in impedance (E_7) around a basal impedance level (E_8) of 1.7 kilohms. Illustration C shows the change in output for a 10-ohm change, while illustrations A and B show a 1-ohm change.

As illustrated previously, this impedance plethysmograph can be adjusted to handle different impedance values. The lower limit, determined by the constant current source, is 40 ohms. This is the lowest resistance for which the current source will maintain a constant current. The maximum limit is determined by the differential amplifier (A_3 to A_5). The minimum voltage gain of this stage is three. Therefore, approximately 4 v. is the highest voltage across the body that can be measured without using saturation. This corresponds to approximately 15 kilohms of body impedance. By adjusting R_8 , R_{20} , and R_{31} , any range between 40 ohms and 15 kilohms can be obtained.

Additional feature

In many cases impedance plethysmograph studies are made with frequencies other than 100 kHz. Provision is included through switch S_1 to permit the use of an external oscillator, which for best operation should have a 2- or 3-v. output. In this case the impedance ranges mentioned above are valid. For other oscillator voltages the device will have to be recalibrated. Care should be taken to insure that there is no d. c. voltage at the oscillator output.

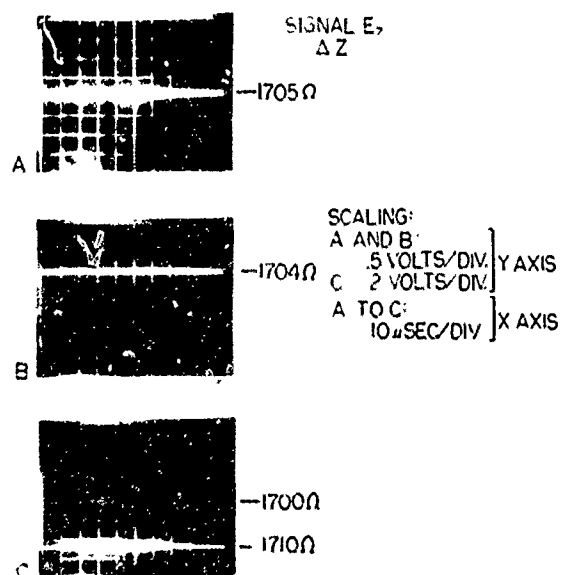

FIGURE 9

Voltage change for a 1-ohm and a 10-ohm change on a base impedance level of 1.7 kilohms.

Previous investigators have used both the bipolar (2, 11) and tetrapolar electrode (1, 9) configurations in their body impedance studies. Since each of these systems has special advantages, this impedance plethysmograph will accommodate both. The selection of configuration is made using switch S_3 .

In the bipolar position of S_3 , current is supplied through the outer pair of electrodes. The impedance changes are measured at the same pair of electrodes. In the tetrapolar position, current is supplied through the same outer pair of electrodes as in the bipolar system; however, the signal measurement is made from the inner pair of electrodes.

Special considerations

Amplifiers A_2 to A_7 should have a frequency response of at least 100 kHz. The Burr-Brown 3307 operational amplifier performed satisfactorily in the circuit. Because of the high gain in the voltage offset circuit, an operational amplifier with low noise and drift characteristics is used for A_8 .

The necessity of balanced voltage outputs requires the use of resistors with tolerances of 1% or better. Preliminary tests have shown that the wire-wound resistors exhibit inductive tendencies at 100 kHz; therefore, film resistors were used wherever possible.

Alignment

Figure 10 shows circuit voltages when the device is adjusted to read a basal body impedance of 1.7 kilohms midscale. It should be realized that these will change for different scales, but the basic waveform will remain the same.

III. RESULTS

Final design

Figure 11 shows the completed impedance plethysmograph. The inserts show the output jacks, operating controls, and electrode inputs.

Subject test

Several tests were performed with the impedance plethysmograph to verify its operation: normal, impulse, inhale-and-hold breathing

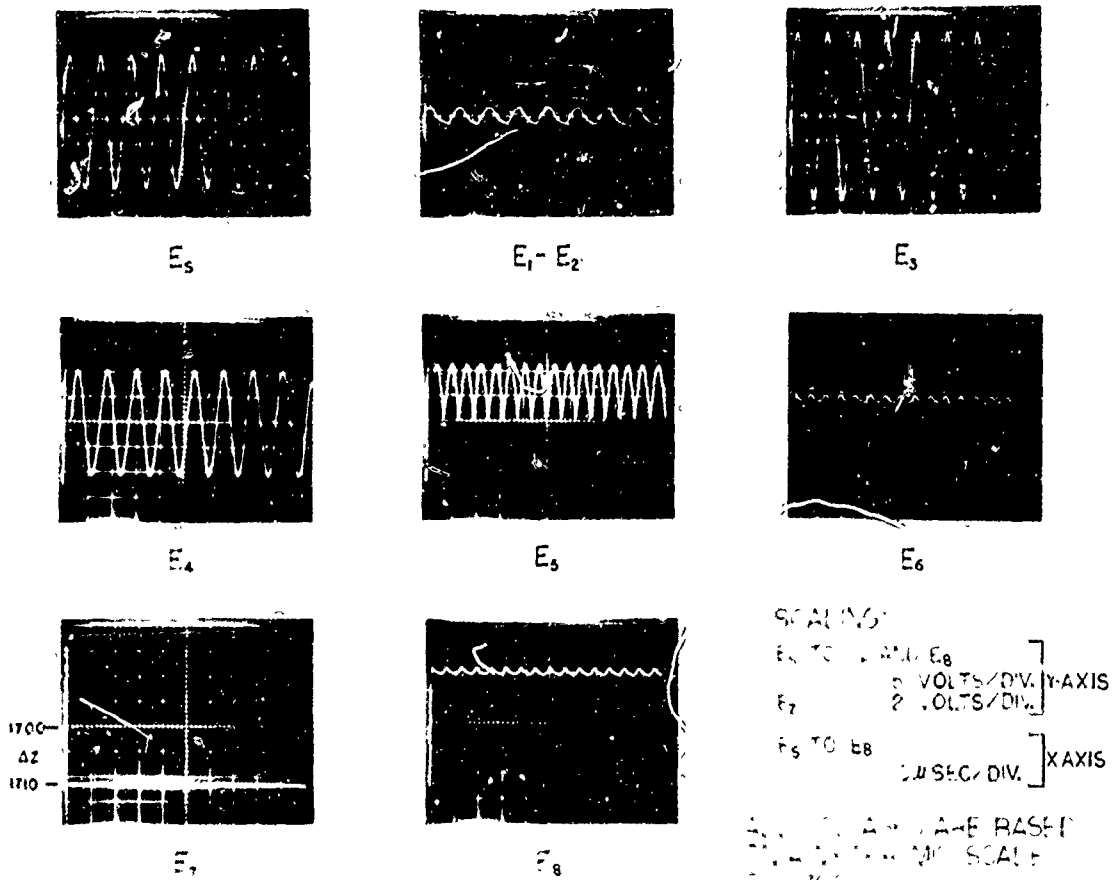

FIGURE 10

Point-by-point voltage waveforms for each portion of impedance plethysmograph circuit. Voltage nomenclature keyed to block diagram.

sequences, and an arm-movement exercise for the sitting and supine positions. The test sequence was used for both the bipolar and tetrapolar electrode systems. Standard Beckman ECG electrodes and Cambridge electrode paste were used in this test. The current electrodes were placed at the sixth intercostal space along the midaxillary line. The recording electrodes were placed 1.25 inches in front of and on the same line as the current electrodes. The only skin preparation was cleaning with acetone.

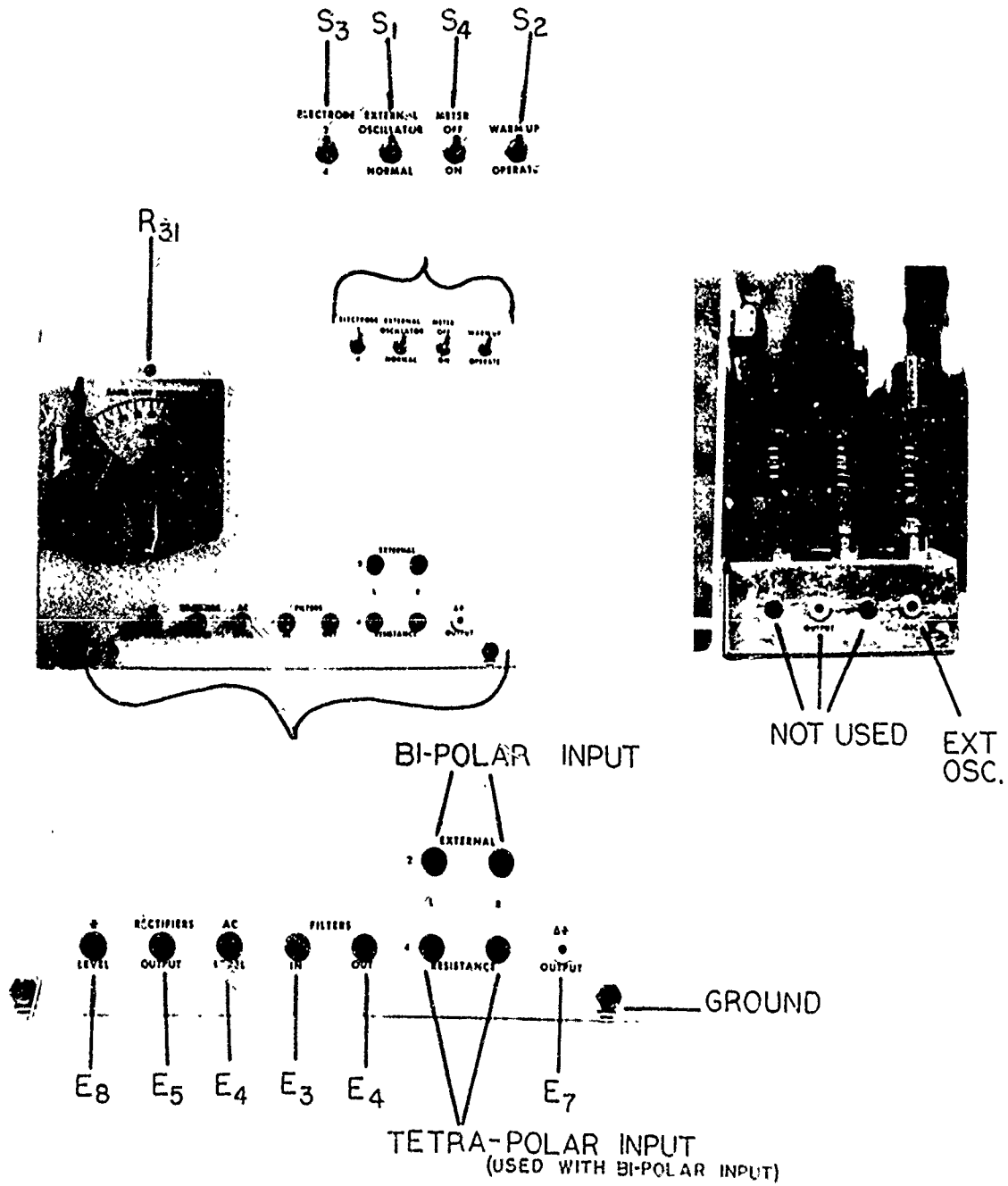

FIGURE 11

Impedance plethysmograph showing operating controls and connections.

The transthoracic impedance and respiratory volume of the test sequence mentioned above are shown in figures 12 through 15: the results of a bipolar electrode system used in the supine and sitting

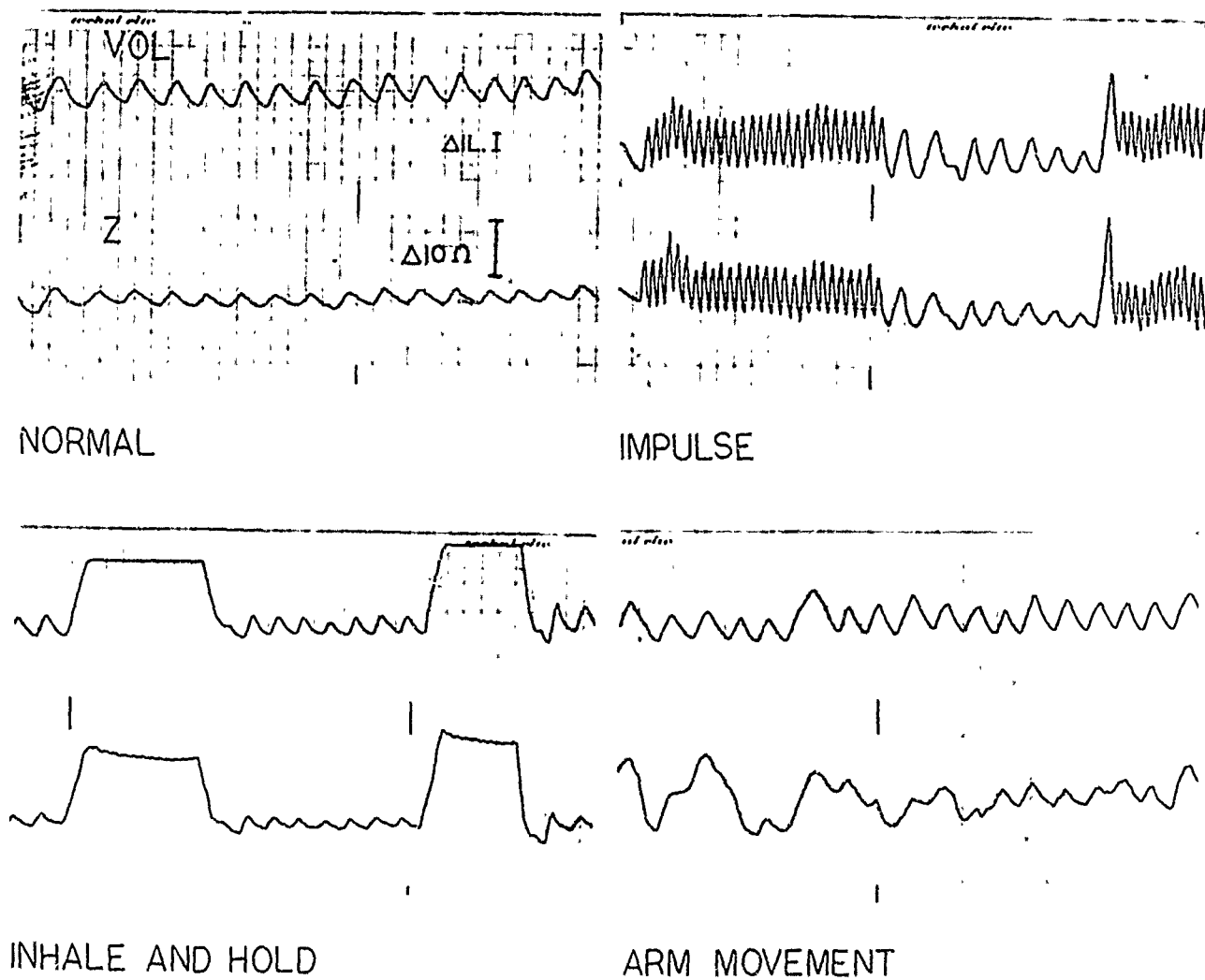

FIGURE 12

Results of measuring thoracic impedance change on a human subject in the supine position with a bipolar electrode system.

positions (figs. 12, 13) and of a tetrapolar electrode system used in the supine and sitting positions (figs. 14, 15).

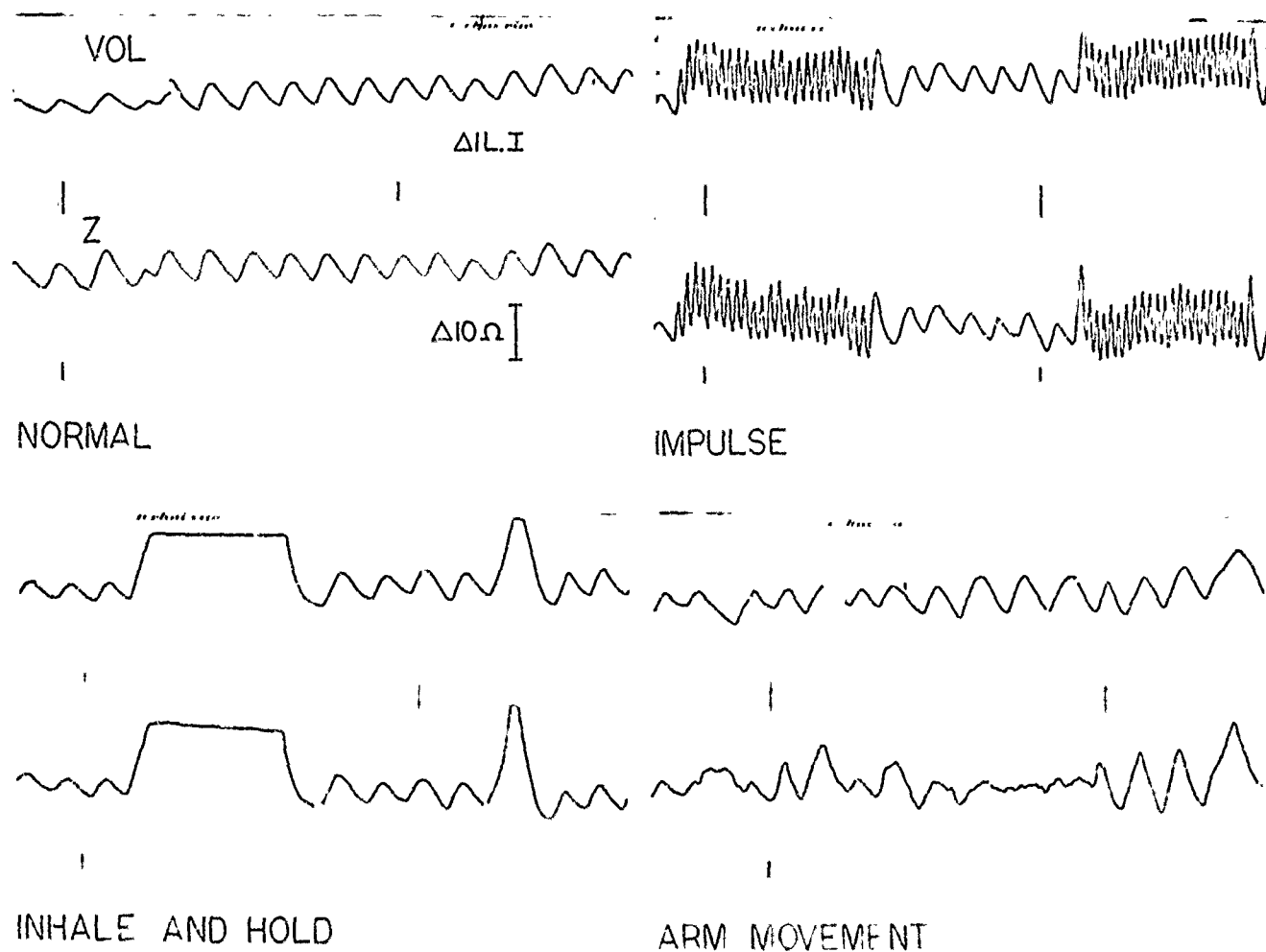

FIGURE 13

Results of measuring thoracic impedance change on a human subject in the sitting position with a bipolar electrode system.

IV. CONCLUSION

An impedance plethysmograph was designed, built, and tested. Several safety features were included to protect the subject as well as the equipment. This device normally operates at 100 kHz, but can accept other frequencies. The system uses the constant current

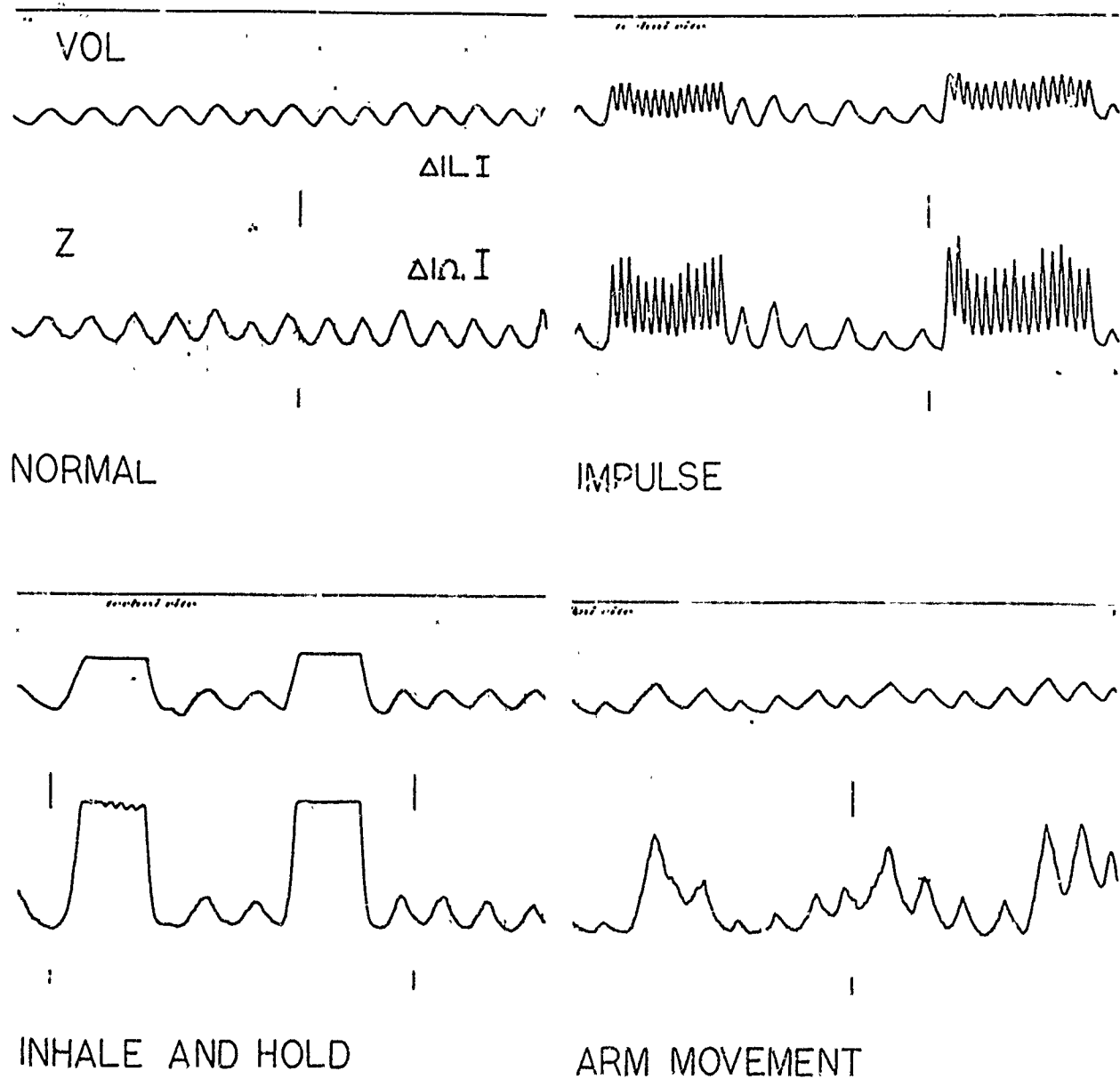

FIGURE 14

Results of measuring thoracic impedance change on a human subject in the supine position with a tetrapolar electrode system.

method to make accurate measurements. It is capable of determining the basal impedance level as well as minute respiratory impedance changes, and of recording these data on either paper or magnetic tape. The sensitivity of the device is sufficient to show a 1-ohm change over a basal body impedance level between 40 ohms and 15 kilohms, using either the bipolar or tetrapolar electrode system.

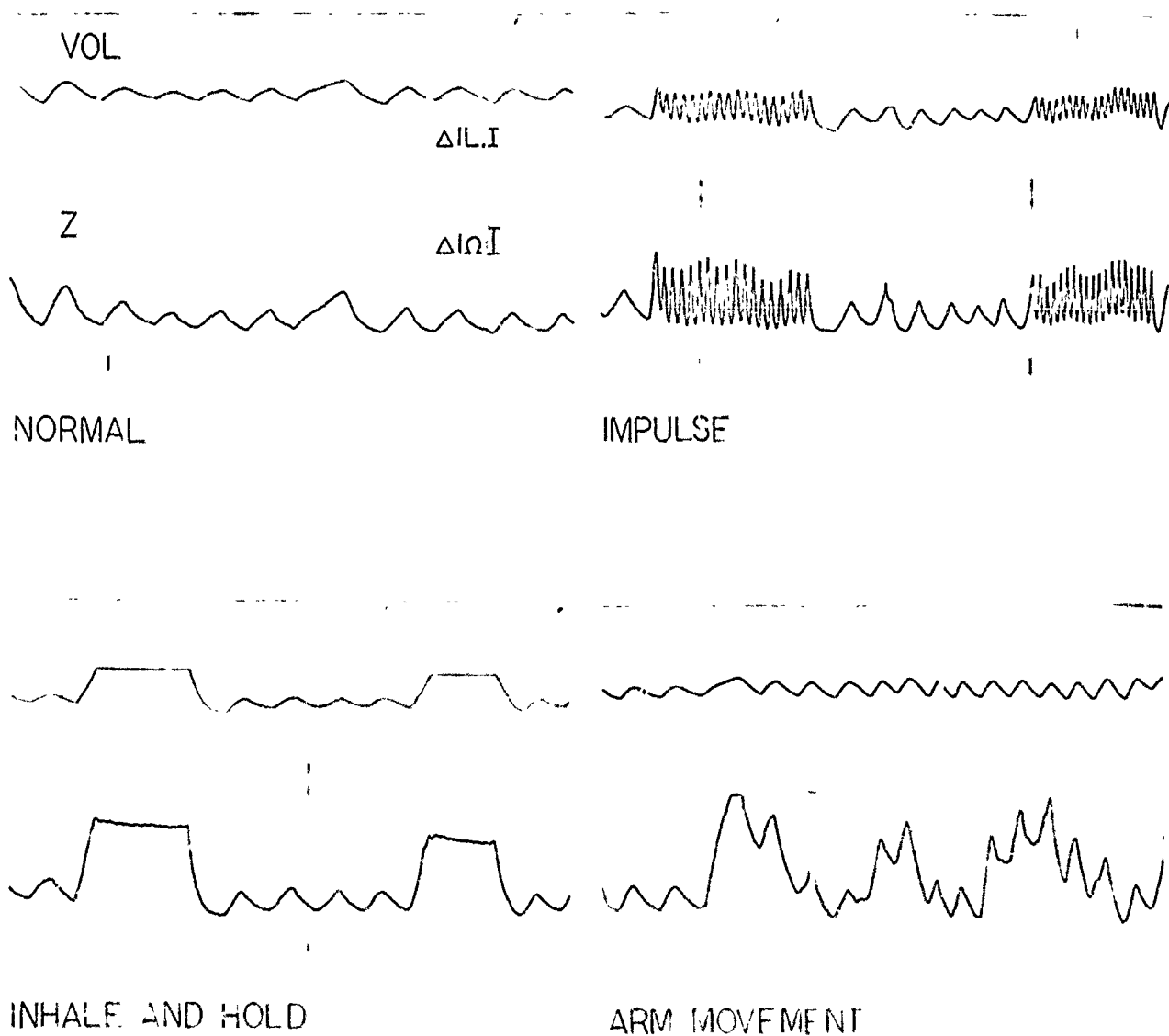

FIGURE 15

Results of measuring thoracic impedance change on a human subject in the sitting position with a tetrapolar electrode system.

BIBLIOGRAPHY

1. Allison, R. D. , E. L. Holmes, and J. Nyboer. Volumetric dynamics of respiration as measured by electrical impedance plethysmography. *J. Appl. Physiol.* 19:166-173 (1964).
2. Baker, L. E. , L. A. Geddes, and H. E. Hoff. Quantitative evaluation of impedance spirometry in man. *Amer. J. Med. Electron.* 4:73-77 (1965).
3. Burr-Brown Research Corp. Handbook of operational amplifier applications, pp. 45-69. Tucson:Burr-Brown Research Corp. , 1963.
4. Geddes, L. A. , and L. E. Baker. The specific resistance of biological material: A compendium of data for the biomedical engineer and physiologist. *Med. Biol. Engin.* 5:271-293 (1967).
5. Geddes, L. A. , et al. Hazards in the use of low frequency for the measurement of physiological events by impedance. *Med. Biol. Engin.* 7:289-295 (1969).
6. Geddes, L. A. , and H. E. Hoff. The measurement of physiological events by impedance change. *Proc. San Diego Symp. Biomed. Engin.* 3:115-122. La Jolla, Calif. , 1964.
7. Geddes, L. A. , et al. The impedance pneumograph. *Aerosp. Med.* 33:28-33 (1962).
8. Geddes, L. A. , and L. E. Baker. Response to passage of electric current through the body. *J. Ass. Advan. Med. Inst.* 5:13-18 (1971).
9. Gessert, W. L. , K. A. Reid, and J. Nyboer. Reliability of tetrapolar electrical impedance plethysmography. *Biomed. Sci. Instrum.* 5:143-152 (1969).
10. Hamilton, L. H. , J. D. Beard, and R. C. Kory. Impedance measurement of tidal volume and ventilation. *J. Appl. Physiol.* 20:565-568 (1965).
11. Kinnen, E. , W. Kubicek, and G. Turton. Thoracic cage impedance measurements: Dynamic characteristics of an impedance pneumograph. SAM-TR-63-100, Dec. 1963.
12. Lloyd, A. G. Ideal rectifier uses equal-value resistors. *Analog Dialogue* 1(2):12-13 (1968).

13. Nyboer, J. , S. Bagno, and L. F. Nims. The impedance plethysmograph, an electrical volume recorder. Report No. 149. National Research Council, Committee on Aviation Medicine, Washington, D. C. , 1943.
14. Pacela, A. F. Impedance pneumography: A survey of instrumentation techniques. Med. Biol. Engin. 4:1-15 (1966).
15. Pasquali, E. Problems in impedance pneumography: Electrical characteristics of skin and lung tissue. Med. Biol. Engin. 5:249-258 (1967).
16. Philbrick/Nexus Research. Applications manual for operational amplifiers, pp. 64-102. Dedham, Mass. : Philbrick/Nexus Research, 1968.
17. Schwan, H. P. Electrical properties of body tissue and impedance plethysmography. IRE Trans. Med. Electron. PGME 3:32-46 (1955).
18. Yates, J. W. Effects of limited movement on the impedance plethysmograph signal: A preliminary study. SAM-TR-70-67, Sept. 1970.