

740930

AD

Best Available Copy

Reproduced by the
CLEARINGHOUSE
for Federal Scientific & Technical
Information Springfield Va. 22151

NOTICES

When US Government drawings, specifications, or other data are used for any purpose other than a definitely related Government procurement operation, the Government thereby incurs no responsibility nor any obligation whatsoever, and the fact that the Government may have formulated, furnished, or in any way supplied the said drawings, specifications, or other data, is not to be regarded by implication or otherwise, as in any manner licensing the holder or any other person or corporation, or conveying any rights or permission to manufacture, use, or sell any patented invention that may in any way be related thereto.

Organizations and individuals receiving announcements or reports via the Aerospace Medical Research Laboratory automatic mailing lists should submit the addressograph plate stamp on the report envelope or refer to the code number when corresponding about change of address or cancellation.

Do not return this copy. Retain or destroy.

Please do not request copies of this report from Aerospace Medical Research Laboratory. Additional copies may be purchased from:

National Technical Information Service
5885 Port Royal Road
Springfield, Virginia 22151

AIR FORCE: 31-3-72/500

ACCESSION NO.	
SPSTI	WRITE SECTION <input checked="" type="checkbox"/>
ADC	AIRF SECTION <input type="checkbox"/>
UNANNOUNCED	<input type="checkbox"/>
JUSTIFICATION	
DISTRIBUTION/AVAILABILITY CODES	
DIST.	AVAIL. and/or SPECIAL
A	

DOCUMENT CONTROL DATA - R & D

(Security classification of title, body of abstract and indexing annotation must be entered when the overall report is classified)

1. ORIGINATING ACTIVITY (Corporate author) Webb Associates, Inc. Yellow Springs, Ohio 45387*		Aerospace Medical Research Laboratory, AMD, AFSC, Wright-Patterson AFB, Ohio 45433**		20. REPORT SECURITY CLASSIFICATION UNCLASSIFIED	
				20. GROUP N/A	
2. REPORT TITLE HUMAN FORCE EXERTIONS IN AIRCRAFT CONTROL LOCATIONS					
3. DESCRIPTIVE NOTES (Type of report and inclusive dates)					
4. AUTHOR(S) (First name, middle initial, last name) Marvin L. Thordsen*, K. H. Eberhard Kroemer**, and Lloyd L. Laubach*					
5. REPORT DATE February 1972		70. TOTAL NO. OF PAGES 80		70. NO. OF REFS 16	
22. CONTRACT OR GRANT NO. F33615-71-C-1087		20. ORIGINATOR'S REPORT NUMBER(S)			
6. PROJECT NO. 7184					
7. Task No. 718408		20. OTHER REPORT NO(S) (Any other numbers that may be assigned this report)			
8. Work Unit 718408018		AMRL-TR-71-119			
10. DISTRIBUTION STATEMENT Approved for public release; distribution unlimited					
11. SUPPLEMENTARY NOTES			12. SPONSORING MILITARY ACTIVITY Aerospace Medical Research Laboratory Aerospace Medical Div., AF Systems Command, Wright-Patterson AFB, Ohio 45433		
13. ABSTRACT Experiments were conducted to measure the maximum isometric forces male subjects could exert at six locations of hand-operated aircraft controls. Forces were measured in two vertical and four to eight horizontal directions. The subjects (n=51) sat in a simulated aircraft seat and exerted forces on a cylindrical handle. Selected anthropometric dimensions were obtained on the subjects and compared with those from the 1967 USAF anthropometric survey of flying personnel. Summary statistics, including the mean, standard error of the mean, standard deviation, standard error of the standard deviation, coefficient of variation, symmetry, kurtosis, and selected percentiles, are presented for each of the 44 force exertion measures. An analysis of the magnitude and direction of the force components, recorded in a plane orthogonal to the requested direction, is presented for each of the 44 primary force measurements. The intercorrelations for the 44 exertions, and the correlations between the force exertions and the anthropometric dimensions are presented for 11 of the subjects who completed the 44 force exertion measurements on two separate occasions.					

14 KEY WORDS	LINK A		LINK B		LINK C	
	ROLE	WT	ROLE	WT	ROLE	WT
Anthropometry Forces Exertions Statistics Strength Aircraft controls Intercorrelations Muscular strength Biomechanics Controls						

ERRATA

Security Classification

DOCUMENT CONTROL DATA - R & D		
<i>(Security classification of title, body of abstract and indexing annotation must be entered when the overall report is classified)</i>		
1. ORIGINATING ACTIVITY (Corporate author) Webb Associates, Inc. Yellow Springs, Ohio 45387*		2a. REPORT SECURITY CLASSIFICATION Unclassified
Aerospace Medical Research Laboratory, AMD, AFSC, Wright-Patterson AFB, Ohio 45433**		2b. GROUP N/A
3. REPORT TITLE HUMAN FORCE EXERTIONS IN AIRCRAFT CONTROL LOCATIONS.		
4. DESCRIPTIVE NOTES (Type of report and inclusive dates)		
5. AUTHOR(S) (First name, middle initial, last name) Marvin L. Thordsen*, K. H. Eberhard Kroemer**, and Lloyd L. Laubach*		
6. REPORT DATE February 1972	7a. TOTAL NO. OF PAGES 80	7b. NO. OF REFS 16
8a. CONTRACT OR GRANT NO. F33615-71-C-1087	9a. ORIGINATOR'S REPORT NUMBER(S)	
b. PROJECT NO. 7184	9b. OTHER REPORT NO(S) (Any other numbers that may be assigned this report) AMRL-TR-71-119	
c. Task No. 718408		
d. Work Unit 718408018		
10. DISTRIBUTION STATEMENT Approved for public release; distribution unlimited.		
11. SUPPLEMENTARY NOTES	12. SPONSORING MILITARY ACTIVITY Aerospace Medical Research Laboratory, Aerospace Medical Div., AF Systems Command, Wright-Patterson AFB, CH 45433	
13. ABSTRACT Experiments were conducted to measure the maximum isometric forces male subjects could exert at six locations of hand-operated aircraft controls. Forces were measured in two vertical and four to eight horizontal directions. The subjects (n=51) sat in a simulated aircraft seat and exerted forces on a cylindrical handle. Selected anthropometric dimensions were obtained on the subjects and compared with those from the 1967 USAF anthropometric survey of flying personnel. Summary statistics, including the mean, standard error of the mean, standard deviation, standard error of the standard deviation, coefficient of variation, symmetry, kurtosis, and selected percentiles, are presented for each of the 44 force exertion measures. An analysis of the magnitude and direction of the force components, recorded in a plane orthogonal to the requested direction, is presented for each of the 44 primary force measurements. The intercorrelations for the 44 exertions, and the correlations between the force exertions and the anthropometric dimensions are presented. Test-retest differences are presented for 11 of the subjects who completed the 44 force exertion measurements on two separate occasions.		

DD FORM 1473
1 NOV 65

Security Classification

FOREWORD

This study was prepared under Project 7184, "Human Engineering in Advanced Systems," Task 718408, "Anthropology for Design," Work Unit 718408007, "Biomechanics." It was a combined effort of the Anthropology Research Project, Webb Associates, Inc., Yellow Springs, Ohio and the Anthropology Branch, Human Engineering Division, Aerospace Medical Research Laboratory, Wright-Patterson Air Force Base, Ohio.

Project scientists were Mr. Marvin L. Thordsen and Dr. Lloyd L. Laubach, Webb Associates, Inc., under contract F33615-71-C-1087, and K. H. Eberhard Kroemer, Dr. Ing., of the Anthropology Branch. Mr. Charles E. Clauser, Chief, Anthropology Branch, was the contract monitor for the Aerospace Medical Research Laboratory.

The arm strength/reach measuring device used in this study was designed by Mr. Kenneth W. Kennedy, Anthropology Branch. Dr. A. R. Marko, Chief, and Mr. James H. Lovin, of the Medical Electronics Branch, Environmental Medicine Division, Aerospace Medical Research Laboratory, assisted by setting up the recording equipment.

The authors are indebted to Dr. John T. McConville, Webb Associates, Inc., and Dr. Melvin J. Warrick, Associate Director, Human Engineering Division, Aerospace Medical Research Laboratory, for their critical reading of the manuscript and for suggesting many improvements. Thanks are due to Mr. Edmund Churchill, Webb Associates, Inc., who performed the statistical analysis of the data.

This research was funded by the Aerospace Medical Research Laboratory (Anthropology Branch) and the Joint Army-Navy Aircraft Instrumentation Research (JANAIR) working group. Mr. Kenneth W. Kennedy, Aerospace Medical Research Laboratory, performed the necessary liaison between JANAIR and Webb Associates, Inc.

This technical report has been reviewed and is approved.

CLINTON L. HOLT, Colonel, USAF, MC
Commander
Aerospace Medical Research Laboratory

TABLE OF CONTENTS

<i>Section</i>	<i>Page</i>
I INTRODUCTION	1
II EQUIPMENT	3
III EXPERIMENTAL CONDITIONS	5
Body Support-Posture	5
Handle Arrangements and Force Exertions.....	5
Handle Location	5
Handle Orientation	5
Direction of Force Exertion	6
IV PROCEDURE	9
V SUBJECTS	11
VI RESULTS	13
VII DISCUSSION OF RESULTS	59
Comparison With The Results of Other Studies.....	59
Effects of Handle Location and Exertion Directions	
On The Magnitude of Force.....	59
Component Forces	59
Mode of Operation	60
Correlations Among Measurements.....	60
VIII SUMMARY AND CONCLUSIONS	61
APPENDIX I Descriptions of Anthropometric	
Measurements and Grip Strength.....	62
APPENDIX II Statistical Procedures and Terminology.....	63
APPENDIX III Intercorrelation Matrix for the Force Exertions.....	66
APPENDIX IV Correlation Coefficients Between Measures of	
Force Exertions and Body Size,	
Grip Strength, and Age.....	73
APPENDIX V Test-Retest Results of Force Exertions.....	75
REFERENCES	78

LIST OF ILLUSTRATIONS

<i>Figure</i>		<i>Page</i>
1	Dimensions of the Simulated Aircraft Seat.....	3
2	Analysis of Force Exertions.....	4

LIST OF TABLES

<i>Table</i>		<i>Page</i>
1	HANDLE LOCATIONS, ORIENTATIONS, AND DIRECTIONS OF FORCE EXERTIONS	7
2	CHARACTERISTICS OF THE STUDY SAMPLE AS COMPARED WITH THE 1967 USAF SURVEY OF FLYING PERSONNEL.....	11
3	SUMMARY TABLE OF THE 44 FORCE EXERTIONS.....	14
4	STICK: FORWARD FORCE.....	15
5	STICK: BACKWARD FORCE	16
6	STICK: BACKWARD FORCE, INWARD PUSH.....	17
7	STICK: BACKWARD FORCE: TWO HANDS.....	18
8	STICK: LEFT FORCE	19
9	STICK: RIGHT FORCE	20
10	STICK: UP FORCE	21
11	STICK: DOWN FORCE.....	22
12	THROTTLE (SIDEARM CONTROLLER): FORWARD FORCE, HANDLE VERTICAL	23
13	THROTTLE (SIDEARM CONTROLLER): FORWARD FORCE, HANDLE HORIZONTAL	24
14	THROTTLE (SIDEARM CONTROLLER): BACKWARD FORCE, HANDLE VERTICAL	25
15	THROTTLE (SIDEARM CONTROLLER): BACKWARD FORCE, HANDLE HORIZONTAL	26
16	THROTTLE (SIDEARM CONTROLLER): LEFT FORCE.....	27
17	THROTTLE (SIDEARM CONTROLLER): RIGHT FORCE.....	28
18	THROTTLE (SIDEARM CONTROLLER): UP FORCE.....	29
19	THROTTLE (SIDEARM CONTROLLER): DOWN FORCE.....	30
20	COLLECTIVE: FORWARD FORCE.....	31
21	COLLECTIVE: BACKWARD FORCE.....	32
22	COLLECTIVE: LEFT FORCE	33
23	COLLECTIVE: RIGHT FORCE.....	34
24	COLLECTIVE: UP FORCE	35
25	COLLECTIVE: DOWN FORCE	36
26	OVERHEAD CONTROL: FORWARD FORCE.....	37
27	OVERHEAD CONTROL: BACKWARD FORCE.....	38

LIST OF TABLES—Continued

<i>Table</i>		<i>Page</i>
28	OVERHEAD CONTROL: LEFT FORCE	39
29	OVERHEAD CONTROL: RIGHT FORCE.....	40
30	OVERHEAD CONTROL: UP FORCE.....	41
31	OVERHEAD CONTROL: DOWN FORCE.....	42
32	PANEL CONTROL: FORWARD FORCE.....	43
33	PANEL CONTROL: BACKWARD FORCE.....	44
34	PANEL CONTROL: LEFT FORCE.....	45
35	PANEL CONTROL: RIGHT FORCE.....	46
36	PANEL CONTROL: UP FORCE	47
37	PANEL CONTROL: DOWN FORCE.....	48
38	HATCH CONTROL: FORWARD FORCE.....	49
39	HATCH CONTROL: BACKWARD FORCE.....	50
40	HATCH CONTROL: LEFT FORCE.....	51
41	HATCH CONTROL: RIGHT FORCE.....	52
42	HATCH CONTROL: UP FORCE.....	53
43	HATCH CONTROL: DOWN FORCE	54
44	HATCH CONTROL: FORWARD FORCE (ROTATED 45° CLOCKWISE)	55
45	HATCH CONTROL: BACKWARD FORCE (ROTATED 45° CLOCKWISE)	56
46	HATCH CONTROL: LEFT FORCE (ROTATED 45° CLOCKWISE)	57
47	HATCH CONTROL: RIGHT FORCE (ROTATED 45° CLOCKWISE)	58

SECTION I

INTRODUCTION

This report describes experiments designed to measure the maximal ("peak") forces that subjects can exert at selected hand-operated aircraft control locations. The research supplements related previous work by Hunsicker (1955, 1957) and Watt (1963) in which other than "peak" scores were reported.

Three common control locations were evaluated: "Stick," "Throttle," and "Collective." Three other locations were also included: "Overhead Control," "Panel Control," and "Hatch Control."

The primary purpose of this study was to provide engineering data to aid in selecting and arranging aircraft controls.

SECTION II EQUIPMENT

The equipment used in this experiment consisted mainly of a seat, a strain gauge force transducer, and recording equipment. The seat simulated a standard aircraft seat (dimensions are shown in figure 1). It was constructed of metal with hard surfaces replacing the usual seat cushions. No adjustments were made for the individual subjects.

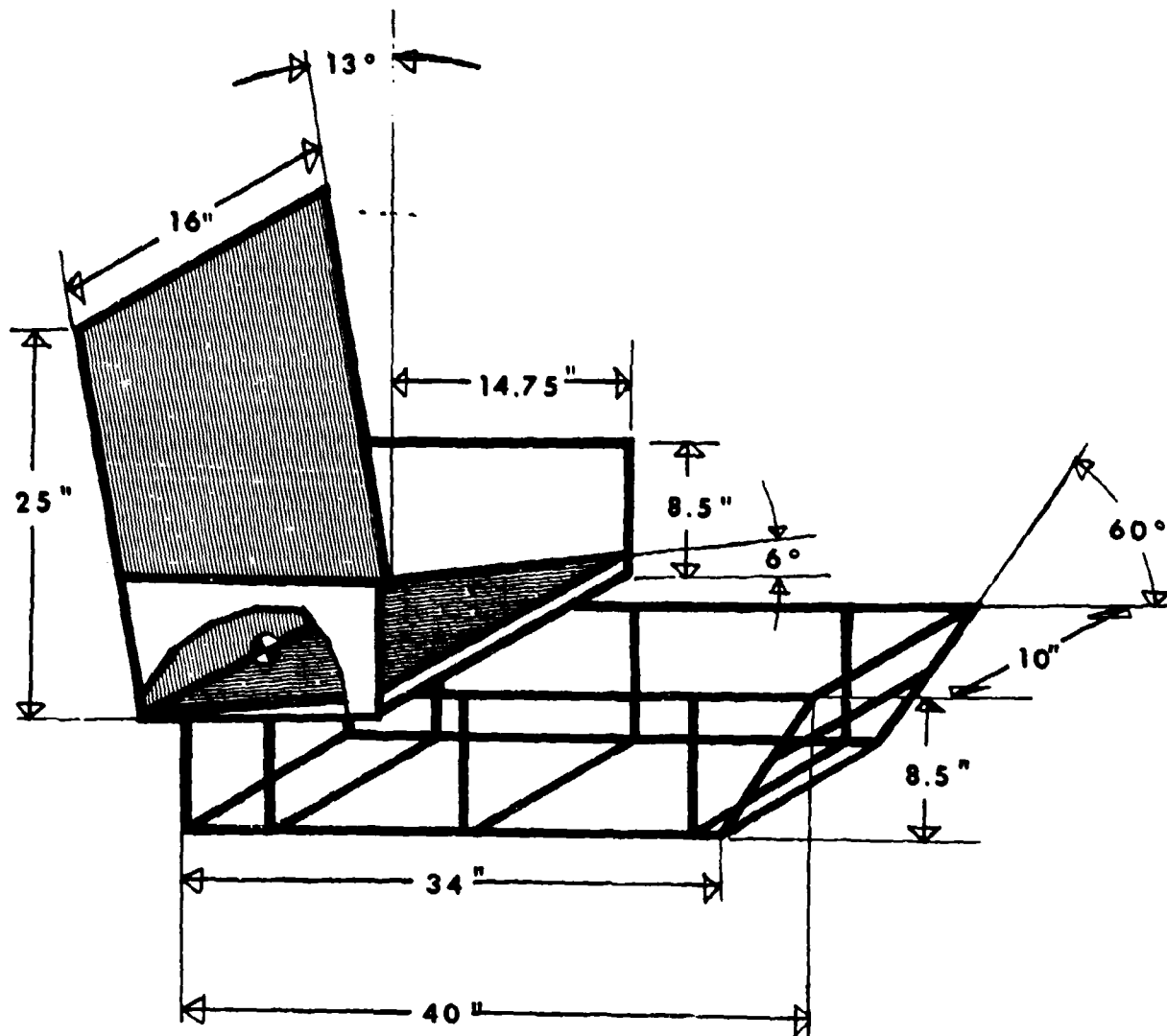

Figure 1. DIMENSIONS OF THE SIMULATED AIRCRAFT SEAT

The force transducer (referred to as the 'handle') was a steel cylinder with a diameter of $1\frac{1}{4}$ inches and a length of 5 inches. Its surface was knurled to minimize slippage when grasped. The handle could freely rotate about the longitudinal axis and could be located in any desired spatial location with respect to Seat Reference Point (SRP).*

Inside the handle were two sets of strain gauges arranged perpendicular to each other, operating on the conventional Wheatstone bridge arrangement. When a force was exerted on the handle, the balance between the two sides of a set of gauges was altered accordingly. The resulting current, proportional to the force applied, was recorded using a Brush Mark 200 recorder. The two sets of strain gauges read out on separate channels of the recorder.

The force exertions requested by the experimenter were in the plane of sensitivity of one of the sets of strain gauges. Any deviation from the requested direction gave two readouts. One readout indicated the force transmitted in the requested direction while the other readout indicated the force transmitted perpendicularly to the requested direction.

Since these readouts monitored forces that were perpendicular to each other, the length and direction of the force vector actually exerted can be assessed by vector addition in the plane established by the recorded components (see figure 2).

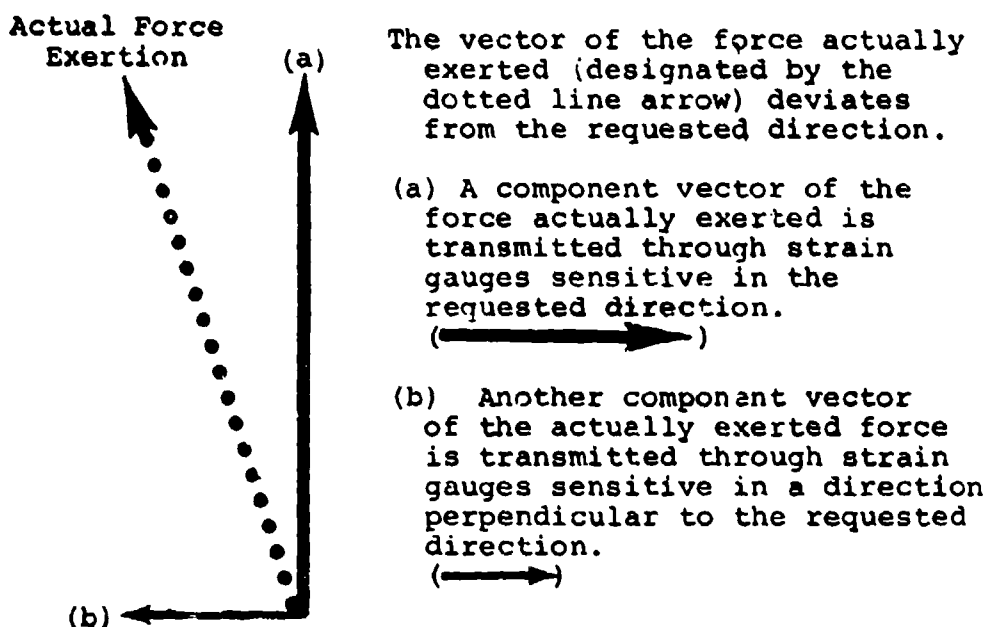

Figure 2. ANALYSIS OF FORCE EXERTIONS

From the record of each exertion in the requested direction, the largest amplitude ("peak") was read. The recordings for the readings perpendicular to the requested direction were taken by reading the amplitude of the perpendicular component at the same time as the "peak" amplitude occurred in the requested direction.

All force recordings were read to the nearest pound with a standard reading error estimated to be one pound; therefore, the readings are correct within ± 1 pound for 68% of the values, ± 2 pounds for 95% of the values, and ± 3 pounds for 99% of the values.

*Seat Reference Point (SRP) is the point of intersection of the midline of the seat pan with the midline of the seat back.

The force transducer (referred to as the 'handle') was a steel cylinder with a diameter of $1\frac{1}{2}$ inches and a length of 5 inches. Its surface was knurled to minimize slippage when grasped. The handle could freely rotate about the longitudinal axis and could be located in any desired spatial location with respect to Seat Reference Point (SRP).*

Inside the handle were two sets of strain gauges arranged perpendicular to each other, operating on the conventional Wheatstone bridge arrangement. When a force was exerted on the handle, the balance between the two sides of a set of gauges was altered accordingly. The resulting current, proportional to the force applied, was recorded using a Brush Mark 200 recorder. The two sets of strain gauges read out on separate channels of the recorder.

The force exertions requested by the experimenter were in the plane of sensitivity of one of the sets of strain gauges. Any deviation from the requested direction gave two readouts. One readout indicated the force transmitted in the requested direction while the other readout indicated the force transmitted perpendicularly to the requested direction.

Since these readouts monitored forces that were perpendicular to each other, the length and direction of the force vector actually exerted can be assessed by vector addition in the plane established by the recorded components (see figure 2).

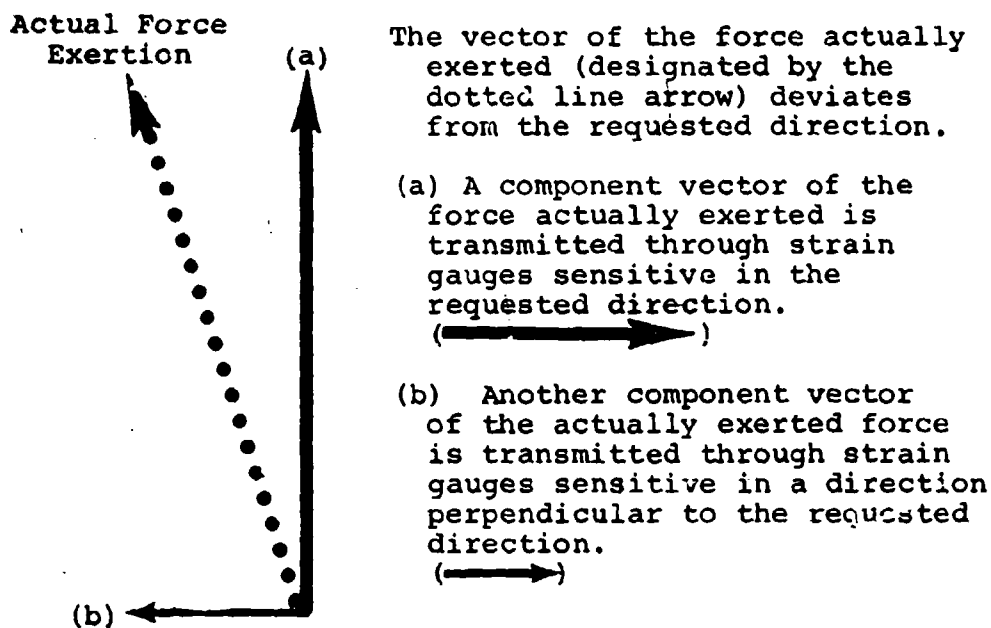

Figure 2. ANALYSIS OF FORCE EXERTIONS

From the record of each exertion in the requested direction, the largest amplitude ("peak") was read. The recordings for the readings perpendicular to the requested direction were taken by reading the amplitude of the perpendicular component at the same time as the "peak" amplitude occurred in the requested direction.

All force recordings were read to the nearest pound with a standard reading error estimated to be one pound; therefore, the readings are correct within ± 1 pound for 68% of the values, ± 2 pounds for 95% of the values, and ± 3 pounds for 99% of the values.

*Seat Reference Point (SRP) is the point of intersection of the midline of the seat pan with the midline of the seat back.

SECTION III

EXPERIMENTAL CONDITIONS

In this study all but one of the exertions were made with the left hand. Exertions with the left hand were selected because they are likely to yield slightly lower strength scores than exertions with the right hand. Design criteria for establishing operational force capability limits generally call for baseline data from the "weaker" limb involved. Heebøll-Nielsen (1964) points out that "... in adult males one must expect a variation in strength of symmetrical muscle groups of 5-14%." However, for most practical purposes the small but obvious statistical differences between force exertions with the left and the right hand can be ignored.

Body Support-Posture

The subject sat, unrestrained, in the seat, grasping the handle assembly during the force exertions. He had support from the seat back, sides, and the foot-rest, all of which he could use to brace against.

During the exertions, the subject was required to:

- Keep the feet on the foot-rest without crossing the legs.
- Keep the right hand on the right thigh. This eliminated the possibility of the subject grasping the chair with the right hand to help brace.
- Have at least one point of the upper back (from the shoulder blades on up) in contact with the back-rest at all times. This restriction allowed some freedom of shoulder rotation from the seat back.

Handle Arrangements and Force Exertions

The handle arrangements and the directions of force exertion used in this study were selected to simulate actual aircraft control operation according to their practical importance, biomechanical implications, and feasibility.

Handle Location: The handle locations were selected to approximate placement of several common aircraft controls. For short reference they are called:

- Stick
- Throttle (Sidearm Controller)
- Collective
- Overhead Control
- Panel Control
- Hatch Control

Their exact locations with respect to Seat Reference Point (SRP) and seat center-line are listed in table 1.

The Stick, Throttle, and Collective positions were selected because they are vital, primary aircraft controls with the Throttle position also approximating the location of a side-arm control. The coordinates for these three controls comply with Military Standards MS 33574 (1969) and MS 33575 (1969).

The remaining three control locations (referred to as Overhead Control, Panel Control, and Hatch Control) were selected since they can pose operational difficulties under G (acceleration) loads. Their locations were established according to biomechanical considerations at the fifth percentile arm-reach envelope of the USAF population as determined by Kennedy (1964).

Handle Orientation: The orientations of the long axis of the handle in the six different locations are listed in table 1. In general, the handle was oriented to approximate the actual hand position used when operating the aircraft control. Thus, in some instances, the handle

was arranged vertically, while in others it was horizontal. In the latter orientation, it was either in the subject's frontal plane* or in a sagittal plane.**

Direction of Force Exertion: The directions of exertions were either vertical (up/down) or horizontal; if horizontal, they were either parallel to the long axis of the seat (forward/backward), or at 90° (left/right), or perpendicular to that axis.

Table 1 describes the handle location, orientations, and directions of force exertion for each of the six control positions.

*The frontal plane refers to any vertical plane perpendicular to the seat center line.

**The sagittal plane refers to any vertical plane either in or parallel to the seat center line.

TABLE 1
HANDLE LOCATIONS, ORIENTATIONS, AND DIRECTIONS
OF FORCE EXERTIONS

<i>Variable</i>	<i>Handle Location</i>	<i>Handle Orientation</i>	<i>Directions of Exertions</i>
Stick	In centerline 12.4 inches above SRP 18 inches forward of SRP	Vertical	1. Forward 2. Backward 3. Inward Push 4. Backward- Two Hands 5. Left 6. Right
		Horizontal Frontal	7. Up 8. Down
Throttle (Sidearm Controller)	10 inches left of SRP 12.4 inches above SRP 20 inches forward of SRP	Vertical	1. Forward
		Horizontal Frontal	2. Forward
		Vertical	3. Backward
		Horizontal Frontal	4. Backward
		Vertical	5. Left 6. Right
		Horizontal Frontal	7. Up 8. Down
Collective	14 inches left of SRP 4.75 inches above SRP 10.3 inches forward of SRP	Horizontal Frontal	1. Forward 2. Backward
		Horizontal Sagittal	3. Left 4. Right 5. Up 6. Down
Overhead Control	10 inches left of SRP 47.3 inches above SRP 0.0 inches forward of SRP	Horizontal Frontal	1. Forward 2. Backward
		Horizontal Sagittal	3. Left 4. Right
		Horizontal Frontal	5. Up 6. Down
Panel Control	10 inches left of SRP 23 inches above SRP 24.7 inches forward of SRP	Vertical	1. Forward 2. Backward 3. Left 4. Right
		Horizontal Frontal	5. Up 6. Down
Hatch Control	18 inches right of SRP 23 inches above SRP 13 inches forward of SRP	Vertical	1. Forward 2. Backward 3. Left 4. Right
		Horizontal	5. Up 6. Down
		Vertical	7. Forward - 45° 8. Backward - 45° 9. Left - 45° 10. Right - 45°

SECTION IV

PROCEDURE

The subject was given a general description of the purpose and procedure of the experiment. The anthropometric dimensions listed in table 2 were taken. Then the subject took his place in the simulated aircraft seat (fig. 1) and specific instructions were verbally relayed about the type, manner, and directions of exertions he was to make.

The experimenter attempted to use an informal and friendly, but businesslike approach with all subjects. The experiment was generally conducted with only the test subject and the experimenter present in the testing room.

Each subject was told:

- Exert an isometric force in the following manner, . . . "Increase gradually until you feel you are at a maximum, . . . then release. Don't jerk."
- He would determine the length of each exertion (they were usually around 3-5 seconds).
- The manner in which to grasp the handle.
- He could rest as long as he desired between exertions, and when ready, go on to the next one.
- There would be 44 exertions with the total experiment time being about 2 hours.
- He would receive one practice exertion to acquaint him with the feel of the apparatus.
- There would be a 15-20 minute break about half way through the experiment.
- He could take other breaks at any time he wished, by just telling the experimenter.
- No smoking, drinking, etc., would be allowed during the exertions, but it was permissible during breaks.
- Not to hurt himself.

The sequence of the force exertions made by the subject was determined by first randomly ordering the six locations of the handle. Within each location, the handle orientations were ordered randomly. Finally, the exertion directions within each orientation were randomly ordered. There was no repetition of exertions unless extenuating circumstances made it impossible to give a maximum exertion during the first attempt. During the exertions the experimenter did not talk to or encourage the subject. After each exertion the subject was told the magnitude of force achieved.

Preceding page blank

SECTION V

SUBJECTS

The 51 male subjects used in this study, all volunteers who were paid (hourly) for their participation, were from either the University of Dayton, Dayton, Ohio (n=45) or the Aerospace Medical Research Laboratory (n=6). Subjects known to have a physical deformity or an organic deficiency were excluded from the study. The close proximity of the handle assembly in the stick position to the experimental chair did not accommodate subjects larger than 110 kilograms (about 242 lb.); therefore, subjects in excess of this weight were excluded from the study.

On each subject, five anthropometric dimensions and three measures of grip strength were obtained, also noted were age and handedness. Descriptions of the anthropometric dimensions and grip strength exertions are discussed in Appendix I.

Table 2 lists age, the anthropometric dimensions, grip strength, and the handedness of the study sample as compared with the 1967 USAF anthropometric survey of flying personnel.

TABLE 2
CHARACTERISTICS OF THE STUDY SAMPLE AS COMPARED
WITH THE 1967 USAF SURVEY OF FLYING PERSONNEL

Variable	Unit	Study Sample (n=51)			
		Mean	SD	99%ile	1%ile
Age	years	22.8	4.9	46.4	17.6
Weight	kg	75.7	11.8	108.9	52.3
Stature	cm	176.1	6.2	190.8	163.9
Sitting Height	cm	91.7	3.3	100.8	85.4
Thumb-Tip Reach	cm	81.3	4.5	93.9	71.7
Lateral Thumb-Tip Reach	cm	107.1	4.9	120.0	98.1
Grip Strength I	N*	490.7	74.9	664.4	301.4
Grip Strength II	N	492.2	74.2	653.3	313.6
Grip Strength III	N	499.9	74.6	621.6	276.6
Grip Strength—Average	N	494.2	70.7	647.0	304.1
Handedness—Right	%	92			
—Left		8			

Variable	Unit	1967 USAF Anthropometric Survey (n=2420)**			
		Mean	SD	99%ile	1%ile
Age	years	20.0	6.3	45.4	22.2
Weight	kg	78.7	9.7	103.3	57.9
Stature	cm	177.3	6.2	191.9	163.3
Sitting Height	cm	93.2	3.2	100.6	86.2
Thumb-Tip Reach	cm	80.3	4.0	90.3	71.2
Lateral Thumb-Tip Reach	cm	—	—	—	—
Grip Strength I	N	552.2	74.3	749.3	389.8
Grip Strength II		—	—	—	—
Grip Strength III		—	—	—	—
Grip Strength—Average		—	—	—	—
Handedness—Right	%	89			
—Left		9			

*One N (Newton) equals 0.225 pounds or 0.102 kiloponds.

**Clauser, C. E. et al., *Anthropometry of Air Force Rated Officers—1967*, Aerospace Medical Research Laboratory, Wright-Patterson AFB, Ohio, unpublished data.

SECTION VI

RESULTS

Table 3 summarizes the means, standard deviations, and ranges for the 44 force exertions. Tables 4 - 47 deal individually with each exertion, and the following are presented for each of the force measurements: the mean, standard error of the mean, standard deviation, standard error of the standard deviation, coefficient of variation, symmetry, kurtosis, sample size, and selected percentiles. A visual and written description for each force exertion is included. The drawings are not meant to be technically correct, only illustrative, and the reader is referred to the written description of the measurement for exact procedures and techniques. A summary table of the force components that were recorded orthogonally to the requested direction is presented at the bottom of each page.

The computations of the statistical measures follow the procedures and techniques described by Churchill (Clauser *et al.*, in press). Appendix II presents a brief discussion of the statistical procedures and the formulas used in this report.

Preceding page blank

TABLE 3
SUMMARY TABLE OF THE 44 FORCE EXERTIONS*

<i>Variable Name</i>	<i>Mean</i>	<i>SD</i>	<i>Range</i>	<i>See Page</i>
STICK				15
Forward Force	68.8	20.4	27-186	16
Backward Force	77.8	13.8	48-114	17
Backward Force, Inward Push	69.1	19.9	30-112	18
Backward Force, Two Hand.	156.2	19.4	100-198	19
Left Force	55.2	11.9	28- 91	20
Right Force	66.3	14.3	33-103	21
Up Force	63.3	14.4	27- 87	22
Down Force	92.3	25.4	33-131	
THROTTLE (Sidearm Controller)				23
Forward Force, Handle Vertical	157.7	34.8	45-229	24
Forward Force, Handle Horizontal	148.2	30.9	61-230	25
Backward Force, Handle Vertical	105.0	16.6	46-140	26
Backward Force, Handle Horizontal	103.0	16.9	54-139	27
Left Force	26.1	9.9	12- 56	28
Right Force	42.6	9.3	17- 64	29
Up Force	41.8	13.3	17- 83	30
Down Force	58.5	15.0	25- 94	
COLLECTIVE				31
Forward Force	67.1	16.0	36- 98	32
Backward Force	58.9	11.6	23- 86	33
Left Force	32.5	13.4	7- 71	34
Right Force	47.3	10.8	23- 73	35
Up Force	85.2	18.4	36-123	36
Down Force	80.0	19.9	34-124	
OVERHEAD CONTROL				37
Forward Force	32.5	10.5	13- 66	38
Backward Force	18.6	4.7	9- 34	39
Left Force	25.9	7.6	13- 53	40
Right Force	25.2	7.3	7- 42	41
Up Force	175.5	54.1	65-308	42
Down Force	98.8	14.6	63-134	
PANEL CONTROL				43
Forward Force	169.8	36.3	75-250	44
Backward Force	111.8	19.6	64-165	45
Left Force	22.8	6.7	11- 45	46
Right Force	35.0	8.2	18- 53	47
Up Force	24.2	5.5	13- 37	48
Down Force	40.4	10.1	21- 75	
HATCH CONTROL				49
Forward Force	35.0	12.5	13- 60	50
Backward Force	45.2	8.4	36- 66	51
Left Force	71.9	13.9	37- 97	52
Right Force	56.9	14.5	30- 98	53
Up Force	28.0	9.2	13- 46	54
Down Force	42.1	7.8	24- 65	55
Forward Force—45°	92.1	15.6	50-129	56
Backward Force—45°	86.8	14.8	36-123	57
Left Force—45°	38.6	9.5	20- 74	58
Right Force—45°	38.1	9.8	21- 67	

*Force exertions reported in pounds.

TABLE 4
STICK: FORWARD FORCE

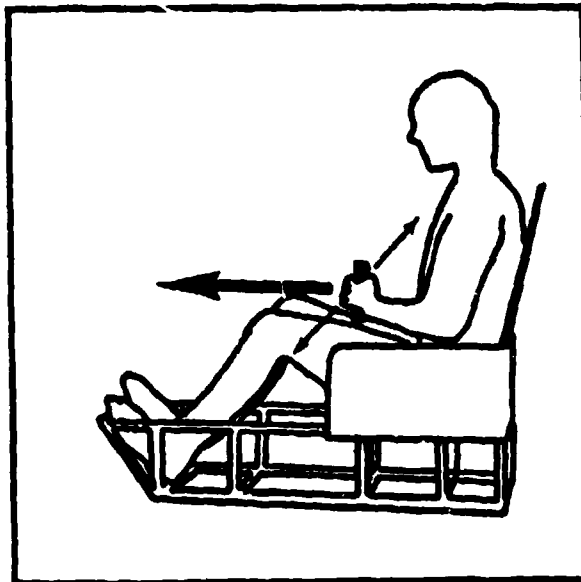

THE SUMMARY STATISTICS

<i>Newtons</i>		<i>Pounds</i>
306.3	Mean	68.8
12.7	SE (Mean)	2.9
90.8	SD	20.4
9.0	SE (SD)	2.0
Coef. of Var. (%)		29.6
Symmetry-Veta I		0.6
Kurtosis-Veta II		3.7
Number of Subj. 51		

THE PERCENTILES

<i>Newtons</i>		<i>Pounds</i>
555.1	99th	124.8
446.2	95th	100.3
355.4	75th	79.9
302.1	50th	67.9
244.3	25th	54.9
161.5	5th	36.3
130.0	1st	29.2

The handle assembly is located in the centerline of the seat, 12.4 inches above SRP, and 13 inches forward of SRP. The handle is oriented vertically and the subject grasps it from the left. The subject is instructed to exert a force in a horizontal plane in the forward direction.

**FORCE COMPONENTS RECORDED ORTHOGONALLY
TO THE REQUESTED DIRECTION**

	<i>Mean lb</i>	<i>SD lb</i>	<i>Maximum lb</i>	<i>Sample Size</i>
LEFT	39.0	—	51.0	2
RIGHT	33.5	13.1	77.0	49

TABLE 5
STICK: BACKWARD FORCE

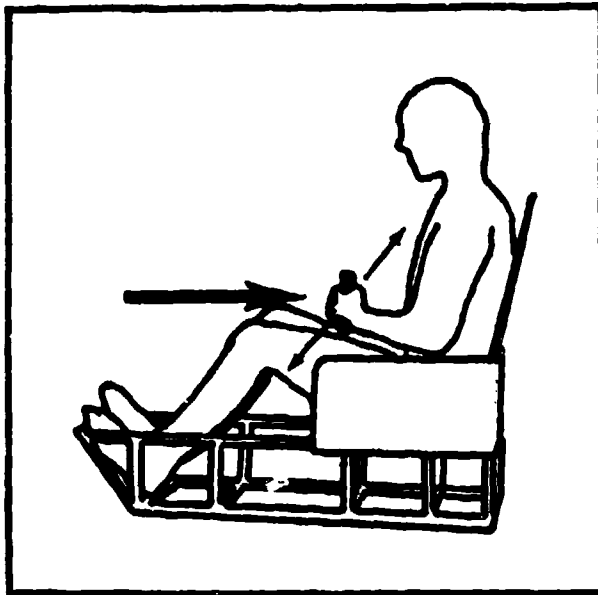

THE SUMMARY STATISTICS

<i>Newton</i>		<i>Pounds</i>
346.2	Mean	77.8
8.6	SE (Mean)	1.9
61.5	SD	13.8
6.1	SE (SD)	1.4
Coef. of Var (%)		17.8
Symmetry-Veta I		0.4
Kurtosis-Veta II		3.0
Number of Subj. 51		

THE PERCENTILES

<i>Newton</i>		<i>Pounds</i>
510.0	99th	114.6
460.0	95th	103.4
385.4	75th	86.6
340.5	50th	76.5
303.3	25th	68.2
256.6	5th	57.7
217.5	1st	48.9

The handle assembly is located in the centerline of the seat, 12.4 inches above SRP, and 13 inches forward of SRP. The handle is oriented vertically and the subject grasps it from the left. The subject is instructed to exert a force in a horizontal plane in the backward direction.

**FORCE COMPONENTS RECORDED ORTHOGONALLY
TO THE REQUESTED DIRECTION**

	<i>Mean lb</i>	<i>SD lb</i>	<i>Maximum lb</i>	<i>Sample Size</i>
LEFT	33.2	11.6	59.0	48
RIGHT	38.0	—	40.0	2

TABLE 6

STICK: BACKWARD FORCE, INWARD PUSH

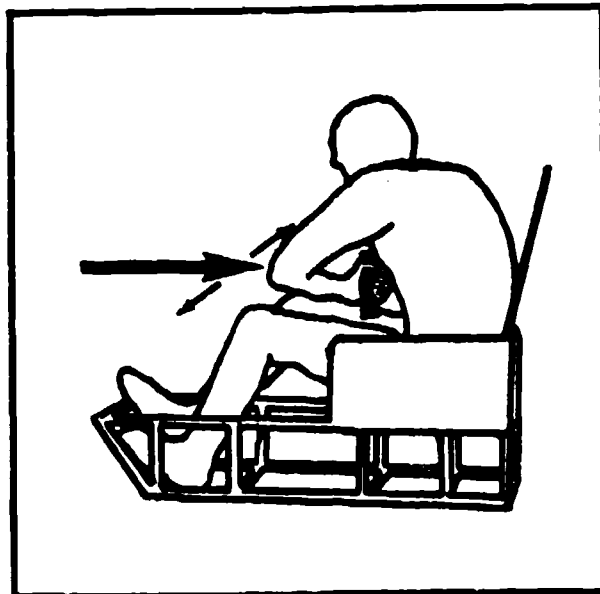

THE SUMMARY STATISTICS

<i>Newton</i> s		<i>Pound</i> s
307.4	Mean	69.1
12.4	SE (Mean)	2.8
88.7	SD	19.9
8.8	SE (SD)	2.0
Coef. of Var. (%)		28.8
Symmetry-Veta I		0.0
Kurtosis-Veta II		2.2
Number of Subj.		51

THE PERCENTILES

<i>Newton</i> s		<i>Pound</i> s
502.1	99th	112.8
454.2	95th	102.1
373.2	75th	83.9
308.3	50th	69.3
241.4	25th	54.3
160.6	5th	36.1
134.6	1st	30.2

The handle assembly is located in the centerline of the seat, 12.4 inches above SRP, and 13 inches forward of SRP. The handle is oriented vertically. The subject is instructed to grasp the handle, lean forward (disregarding the requirement to keep the back in contact with the back rest), swing the left elbow and wrist around so they are forward of the handle assembly, then push towards himself in the backward direction along a horizontal plane.

FORCE COMPONENTS RECORDED ORTHOGONALLY TO THE REQUESTED DIRECTION

	<i>Mean lb</i>	<i>SD lb</i>	<i>Maximum lb</i>	<i>Sample Size</i>
LEFT	25.2	13.3	52.0	13
RIGHT	23.2	11.0	42.0	38

TABLE 7
STICK: BACKWARD FORCE, TWO HANDS

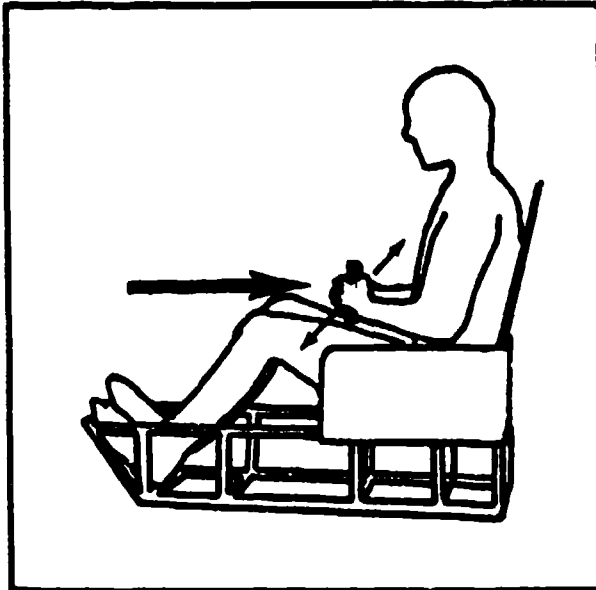

THE SUMMARY STATISTICS

<i>Newtons</i>		<i>Pounds</i>
695.0	Mean	156.2
12.2	SE (Mean)	2.7
86.2	SD	19.4
8.6	SE (SD)	1.9
Coef. of Var. (%)		12.4
Symmetry-Veta I		-0.2
Kurtosis-Veta II		3.1
Number of Subj. 50		

THE PERCENTILES

<i>Newtons</i>		<i>Pounds</i>
880.0	99th	197.8
844.6	95th	189.8
752.7	75th	169.1
691.3	50th	155.4
638.5	25th	143.5
552.1	5th	124.1
442.9	1st	99.5

The handle assembly is located in the centerline of the seat, 12.4 inches above SRP, and 13 inches forward of SRP. The handle is oriented vertically and the subject grasps it with both hands (in whatever manner is comfortable to him). The subject is instructed to exert a force (pull back) in a horizontal plane in the backward direction.

**FORCE COMPONENTS RECORDED ORTHOGONALLY
TO THE REQUESTED DIRECTION**

	<i>Mean lb</i>	<i>SD lb</i>	<i>Maximum lb</i>	<i>Sample Size</i>
LEFT	11.9	8.6	37.0	34
RIGHT	11.9	11.9	32.0	7

TABLE 8
STICK: LEFT FORCE

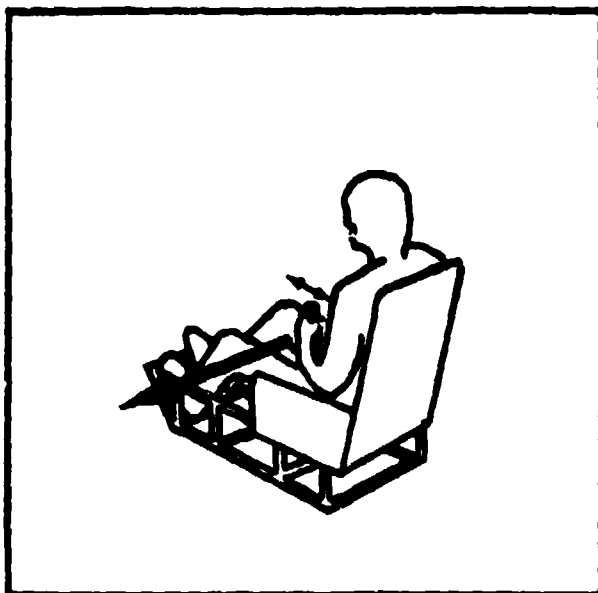

THE SUMMARY STATISTICS

<i>Newton's</i>		<i>Pounds</i>
245.6	Mean	55.2
7.5	SE (Mean)	1.7
58.1	SD	11.9
5.3	SE (SD)	1.2
Coef. of Var. (%)		21.6
Symmetry-Veta I		0.4
Kurtosis-Veta II		3.5
Number of Subj. 50		

THE PERCENTILES

<i>Newton's</i>		<i>Pounds</i>
396.6	99th	89.1
332.9	95th	74.8
276.6	75th	62.2
244.6	50th	55.0
211.2	25th	47.5
160.0	5th	36.0
129.6	1st	29.1

The handle assembly is located in the centerline of the seat, 12.4 inches above SRP, and 13 inches forward of SRP. The handle is oriented vertically and the subject grasps it from the left. The subject is instructed to exert a force in a horizontal plane in the left direction.

**FORCE COMPONENTS RECORDED ORTHOGONALLY
TO THE REQUESTED DIRECTION**

	<i>Mean lb</i>	<i>SD lb</i>	<i>Maximum lb</i>	<i>Sample Size</i>
FORWARD	—	—	—	—
BACKWARD	38.2	15.7	81.0	50

TABLE 9
STICK: RIGHT FORCE

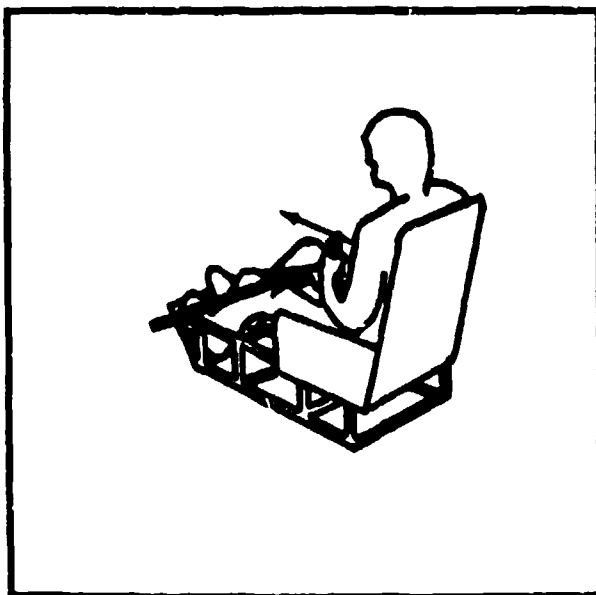

THE SUMMARY STATISTICS

<i>Newtons</i>		<i>Pounds</i>
294.9	Mean	66.3
8.9	SE (Mean)	2.0
63.7	SD	14.3
6.3	SE (SD)	1.4
Coef. of Var. (%)		21.6
Symmetry-Veta I		-0.1
Kurtosis-Veta II		2.8
Number of Subj. 51		

THE PERCENTILES

<i>Newtons</i>		<i>Pounds</i>
443.1	99th	99.6
387.5	95th	87.1
337.5	75th	75.8
299.4	50th	67.3
252.1	25th	56.7
180.9	5th	40.7
154.2	1st	34.7

The handle assembly is located in the centerline of the seat, 12.4 inches above SRP, and 13 inches forward of SRP. The handle is oriented vertically and the subject grasps it from the left. The subject is instructed to exert a force in a horizontal plane in the right direction.

**FORCE COMPONENTS RECORDED ORTHOGONALLY
TO THE REQUESTED DIRECTION**

	<i>Mean lb</i>	<i>SD lb</i>	<i>Maximum lb</i>	<i>Sample Size</i>
FORWARD	23.2	15.5	59.0	33
BACKWARD	12.3	6.5	27.0	12

TABLE 10
STICK: UP FORCE

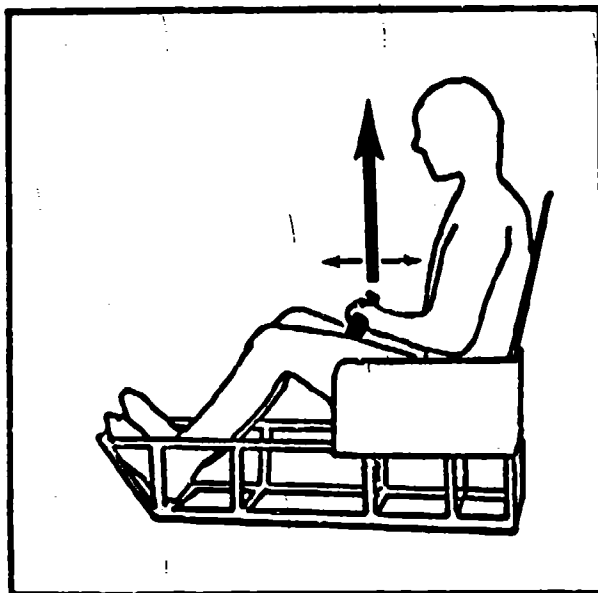

THE SUMMARY STATISTICS

<i>Newton's</i>		<i>Pounds</i>
281.5	Mean	63.3
9.2	SE (Mean)	2.1
64.1	SD	14.4
6.5	SE (SD)	1.5
Coef. of Var. (%)		22.8
Symmetry-Veta I		-0.6
Kurtosis-Veta II		2.8
Number of Subj. 49		

THE PERCENTILES

<i>Newton's</i>		<i>Pounds</i>
392.2	99th	88.1
371.3	95th	83.5
332.1	75th	74.6
290.9	50th	65.4
238.8	25th	53.7
157.3	5th	35.4
112.7	1st	25.3

The handle assembly is located in the centerline of the seat, 12.4 inches above SRP, and 13 inches forward of SRP. The handle is oriented in the horizontal frontal plane and the subject grasps it from the top. The subject is instructed to exert a force in a vertical plane in the up direction.

**FORCE COMPONENTS RECORDED ORTHOGONALLY
TO THE REQUESTED DIRECTION**

	<i>Mean lb</i>	<i>SD lb</i>	<i>Maximum lb</i>	<i>Sample Size</i>
FORWARD	25.5	---	34.0	2
BACKWARD	30.9	11.8	63.0	47

TABLE 11
STICK: DOWN FORCE

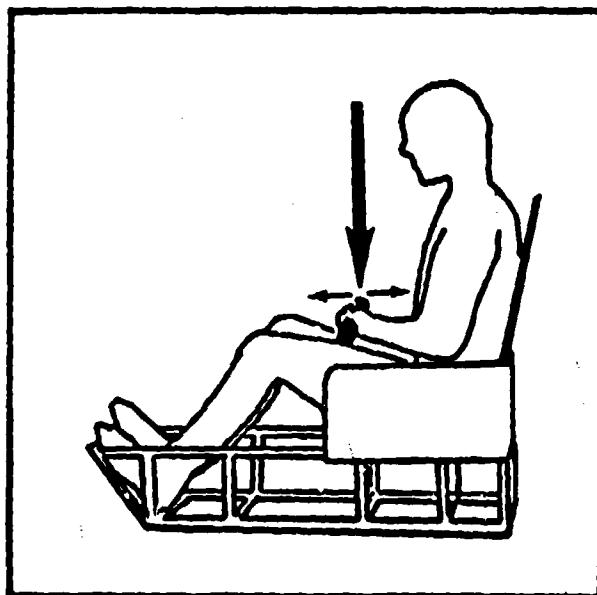

THE SUMMARY STATISTICS

<i>Newton's</i>		<i>Pounds</i>
410.6	Mean	92.3
16.1	SE (Mean)	3.6
112.8	SD	25.4
11.4	SE (SD)	2.6
	Coef. of Var. (%)	27.5
	Symmetry-Veta I	-0.5
	Kurtosis-Veta II	2.5
	Number of Subj.	49

THE PERCENTILES

<i>Newton's</i>		<i>Pounds</i>
585.8	99th	131.6
564.6	95th	126.9
504.0	75th	113.3
429.3	50th	96.5
333.1	25th	74.8
194.4	5th	43.7
142.5	1st	32.0

The handle assembly is located in the centerline of the seat, 12.4 inches above SRP, and 13 inches forward of SRP. The handle is oriented in the horizontal frontal plane and the subject grasps it from the top. The subject is instructed to exert a force in a vertical plane in the down direction.

**FORCE COMPONENTS RECORDED ORTHOGONALLY
TO THE REQUESTED DIRECTION**

	<i>Mean lb</i>	<i>SD lb</i>	<i>Maximum lb</i>	<i>Sample Size</i>
FORWARD	22.5	13.6	58.0	44
BACKWARD	9.3	—	18.0	3

TABLE 12

**THROTTLE (SIDEARM CONTROLLER):
FORWARD FORCE, HANDLE VERTICAL**

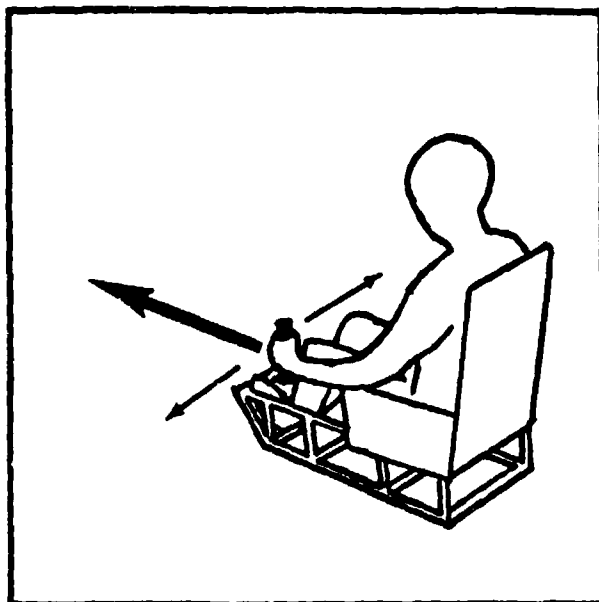

THE SUMMARY STATISTICS

<i>Newton</i>		<i>Pounds</i>
701.5	Mean	157.7
21.7	SE (Mean)	4.9
155.0	SD	34.8
15.4	SE (SD)	3.5
	Coef. of Var. (%)	22.1
	Symmetry-Veta I	-0.9
	Kurtosis-Veta II	4.6
	Number of Subj.	51

THE PERCENTILES

<i>Newton</i>		<i>Pounds</i>
1060.1	99th	238.2
928.1	95th	208.6
802.2	75th	180.2
723.2	50th	162.5
626.2	25th	140.7
417.2	5th	93.8
199.9	1st	44.9

The handle assembly is located 10 inches left of SRP, 12.4 inches above SRP, and 20 inches forward of SRP. The handle is oriented vertically and the subject grasps it from the left. The subject is instructed to exert a force in a horizontal plane in the forward direction.

**FORCE COMPONENTS RECORDED ORTHOGONALLY
TO THE REQUESTED DIRECTION**

	<i>Mean lb</i>	<i>SD lb</i>	<i>Maximum lb</i>	<i>Sample Size</i>
LEFT	11.2	7.5	27.0	20
RIGHT	11.4	8.3	46.0	30

TABLE 13

**THROTTLE (SIDEARM CONTROLLER):
FORWARD FORCE, HANDLE HORIZONTAL**

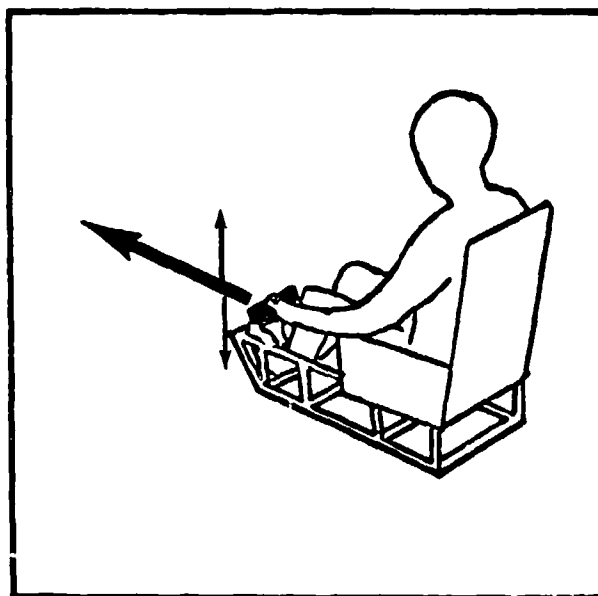

THE SUMMARY STATISTICS

<i>Newton</i>		<i>Pounds</i>
659.7	Mean	148.2
19.3	SE (Mean)	4.3
137.7	SD	30.9
13.6	SE (SD)	3.1
	Coef. of Var. (%)	20.9
	Symmetry-Veta I	0.1
	Kurtosis-Veta II	3.7
	Number of Subj.	51

THE PERCENTILES

<i>Newton</i>		<i>Pounds</i>
1010.4	99th	227.1
898.9	95th	202.0
741.2	75th	166.6
652.5	50th	146.6
576.7	25th	129.6
444.0	5th	99.8
276.7	1st	62.2

The handle is located 10 inches left of SRP, 12.4 inches above SRP, and 20 inches forward of SRP. The handle is oriented in the horizontal frontal plane and the subject grasps it from the top. The subject is instructed to exert a force in a horizontal plane in the forward direction.

**FORCE COMPONENTS RECORDED ORTHOGONALLY
TO THE REQUESTED DIRECTION**

	<i>Mean lb</i>	<i>SD lb</i>	<i>Maximum lb</i>	<i>Sample Size</i>
UP	—	—	—	—
DOWN	39.4	15.5	75.0	51

TABLE 14

**THROTTLE (SIDEARM CONTROLLER):
BACKWARD FORCE, HANDLE VERTICAL**

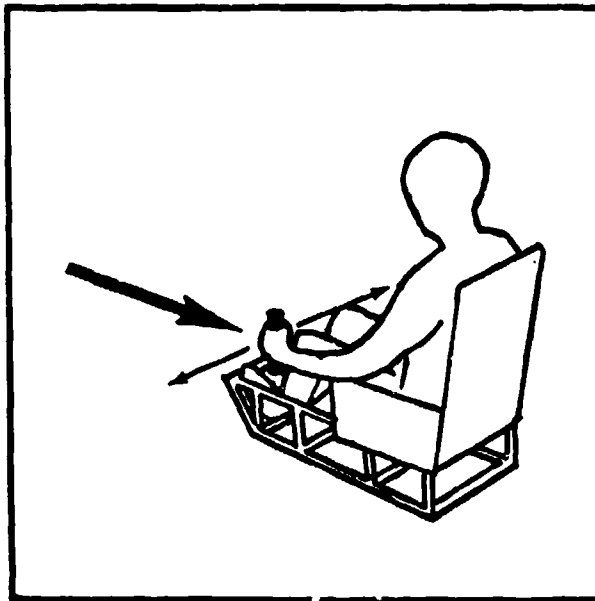

THE SUMMARY STATISTICS

<i>Newton</i>		<i>Pounds</i>
467.1	Mean	105.0
10.4	SE (Mean)	2.3
74.0	SD	16.6
7.8	SE (SD)	1.7
	Coef. of Var. (%)	15.9
	Symmetry-Veta I	-0.3
	Kurtosis-Veta II	4.7
	Number of Subj.	51

THE PERCENTILES

<i>Newton</i>		<i>Pounds</i>
617.0	99th	138.6
605.3	95th	136.0
507.4	75th	114.0
454.2	50th	102.1
427.9	25th	96.2
379.3	5th	85.2
243.0	1st	54.6

The handle assembly is located 10 inches left of SRP, 12.4 inches above SRP, and 20 inches forward of SRP. The handle is oriented vertically and the subject grasps it from the left. The subject is instructed to exert a force in a horizontal plane in the backward direction.

**FORCE COMPONENTS RECORDED ORTHOGONALLY
TO THE REQUESTED DIRECTION**

	<i>Mean lb</i>	<i>SD lb</i>	<i>Maximum lb</i>	<i>Sample Size</i>
LEFT	6.0	—	14.0	4
RIGHT	11.3	7.4	45.0	45

TABLE 15
THROTTLE (SIDEARM CONTROLLER):
BACKWARD FORCE, HANDLE HORIZONTAL

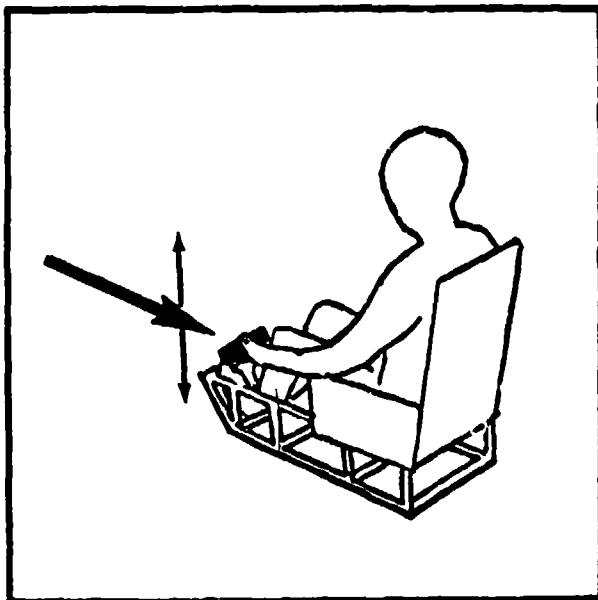

THE SUMMARY STATISTICS

<i>Newtons</i>		<i>Pounds</i>
458.4	Mean	103.0
10.6	SE (Mean)	2.4
75.4	SD	16.9
7.5	SE (SD)	1.7
Coef. of Var. (%)		16.4
Symmetry-Veta I		0.0
Kurtosis-Veta II		3.3
Number of Subj. 51		

THE PERCENTILES

<i>Newtons</i>		<i>Pounds</i>
609.2	99th	136.9
593.2	95th	133.3
506.3	75th	113.8
450.2	50th	101.2
410.4	25th	92.2
353.4	5th	79.4
260.6	1st	58.6

The handle assembly is located 10 inches left of SRP, 12.4 inches above SRP, and 20 inches forward of SRP. The handle is oriented in the horizontal frontal plane and the subject grasps it from the top. The subject is instructed to exert a force in a horizontal plane in the backward direction.

FORCE COMPONENTS RECORDED ORTHOGONALLY
TO THE REQUESTED DIRECTION

	<i>Mean</i> <i>lb</i>	<i>SD</i> <i>lb</i>	<i>Maximum</i> <i>lb</i>	<i>Sample</i> <i>Size</i>
UP	29.1	9.4	48.0	51
DOWN	—	—	—	—

TABLE 16

THROTTLE (SIDEARM CONTROLLER): LEFT FORCE

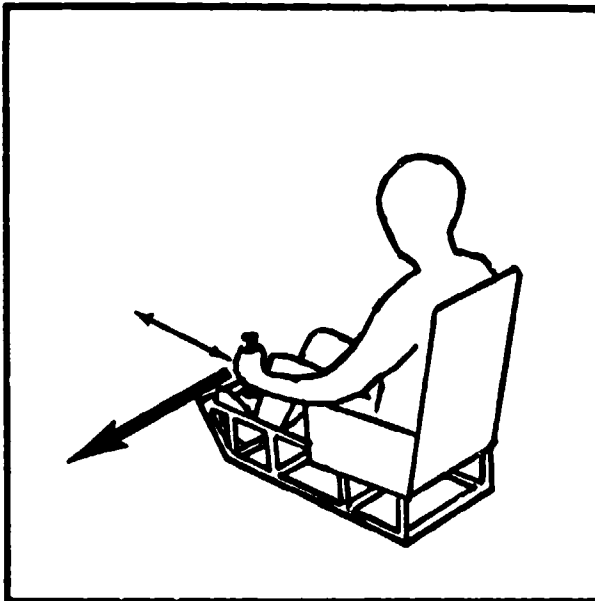

THE SUMMARY STATISTICS

<i>Newton's</i>		<i>Pounds</i>
116.1	Mean	26.1
6.8	SE (Mean)	1.4
44.2	SD	9.9
4.4	SE (SD)	1.0
Coef. of Var. (%)		38.1
Symmetry-Veta I		1.4
Kurtosis-Veta II		4.6
Number of Subj. 50		

THE PERCENTILES

<i>Newton's</i>		<i>Pounds</i>
258.8	99th	58.2
218.0	95th	47.9
139.4	75th	31.8
102.9	50th	23.1
83.1	25th	18.7
69.4	5th	15.6
45.5	1st	10.2

The handle assembly is located 10 inches left of SRP, 12.4 inches above SRP, and 20 inches forward of SRP. The handle is oriented vertically and the subject grasps it from the left. The subject is instructed to exert a force in a horizontal plane in the left direction.

FORCE COMPONENTS RECORDED ORTHOGONALLY TO THE REQUESTED DIRECTION

	<i>Mean lb</i>	<i>SD lb</i>	<i>Maximum lb</i>	<i>Sample Size</i>
FORWARD	35.6	31.8	113.0	22
BACKWARD	22.8	16.8	64.0	22

TABLE 17

THROTTLE (SIDEARM CONTROLLER): RIGHT FORCE

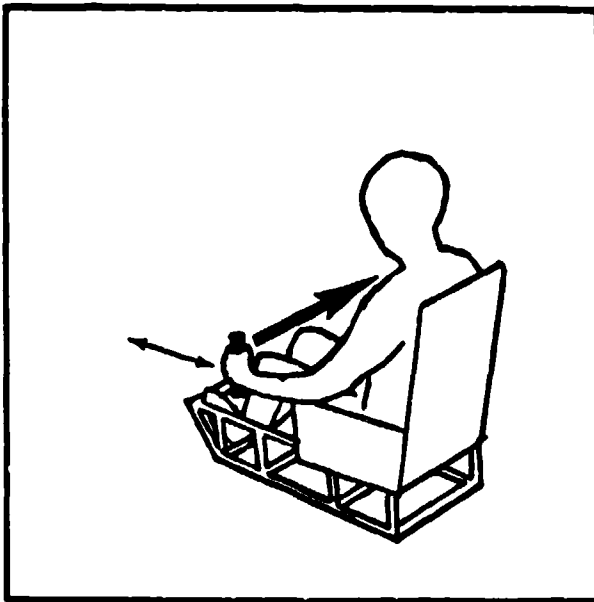

THE SUMMARY STATISTICS

<i>Newtons</i>		<i>Pounds</i>
189.3	Mean	42.6
5.8	SE (Mean)	1.3
41.5	SD	9.3
4.1	SE (SD)	0.9
Coef. of Var. (%)		21.9
Symmetry-Veta I		0.3
Kurtosis-Veta II		3.4
Number of Subj.		51

THE PERCENTILES

<i>Newtons</i>		<i>Pounds</i>
285.0	99th	64.0
269.8	95th	60.6
218.9	75th	48.1
182.0	50th	40.9
163.0	25th	36.6
136.8	5th	30.7
81.9	1st	18.4

The handle assembly is located 10 inches left of SRP, 12.4 inches above SRP, and 20 inches forward of SRP. The handle is oriented vertically and the subject grasps it from the left. The subject is instructed to exert a force in a horizontal plane in the right direction.

FORCE COMPONENTS RECORDED ORTHOGONALLY TO THE REQUESTED DIRECTION

	<i>Mean lb</i>	<i>SD lb</i>	<i>Maximum lb</i>	<i>Sample Size</i>
FORWARD	17.3	8.7	40.0	16
BACKWARD	30.2	18.7	75.0	26

TABLE 18

THROTTLE (SIDEARM CONTROLLER): UP FORCE

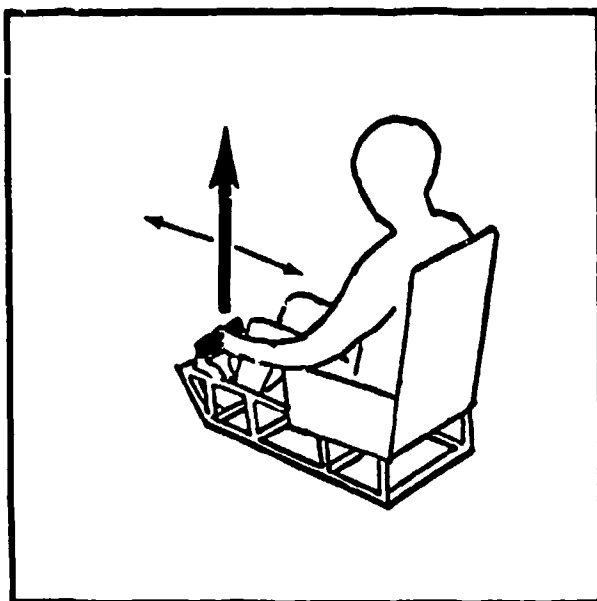

THE SUMMARY STATISTICS

<i>Newtons</i>		<i>Pounds</i>
185.8	Mean	41.8
8.3	SE (Mean)	1.9
59.2	SD	13.3
5.9	SE (SD)	1.3
Coef. of Var. (%)		31.9
Symmetry-Veta I		0.9
Kurtosis-Veta II		4.1
Number of Subj.		51

THE PERCENTILES

<i>Newtons</i>		<i>Pounds</i>
378.7	99th	85.1
300.9	95th	67.6
219.0	75th	49.2
177.6	50th	39.9
144.2	25th	32.4
101.1	5th	22.7
67.1	1st	15.1

The handle assembly is located 10 inches left of SRP, 12.4 inches above SRP, and 20 inches forward of SRP. The handle is oriented in a horizontal frontal plane and the subject grasps it from the top. The subject is instructed to exert a force in a vertical plane in the up direction.

FORCE COMPONENTS RECORDED ORTHOGONALLY TO THE REQUESTED DIRECTION

	<i>Mean lb</i>	<i>SD lb</i>	<i>Maximum lb</i>	<i>Sample Size</i>
FORWARD	30.3	—	39.0	3
BACKWARD	38.9	19.4	85.0	47

TABLE 19

THROTTLE (SIDEARM CONTROLLER): DOWN FORCE

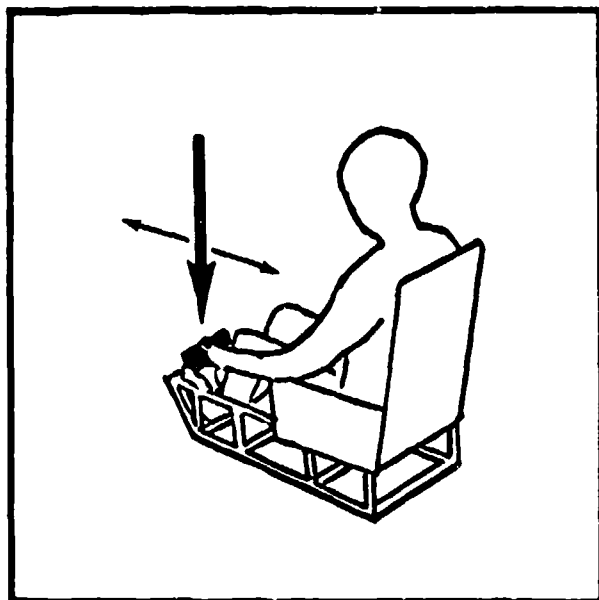

THE SUMMARY STATISTICS

<i>Newton</i>		<i>Pounds</i>
260.1	Mean	58.5
9.4	SE (Mean)	2.1
66.9	SD	15.0
6.6	SE (SD)	1.5
	Coef. of Var. (%)	25.7
	Symmetry-Veta I	0.2
	Kurtosis-Veta II	3.2
	Number of Subj.	51

THE PERCENTILES

<i>Newton</i>		<i>Pounds</i>
432.5	99th	97.2
382.0	95th	85.8
303.7	75th	68.2
255.4	50th	57.4
213.8	25th	48.0
155.2	5th	34.9
99.3	1st	22.8

The handle assembly is located 10 inches left of SRP, 12.4 inches above SRP, and 20 inches forward of SRP. The handle is oriented in a horizontal frontal plane and the subject grasps it from the top. The subject is instructed to exert a force in a vertical plane in the down direction.

FORCE COMPONENTS RECORDED ORTHOGONALLY TO THE REQUESTED DIRECTION

	<i>Mean lb</i>	<i>SD lb</i>	<i>Maximum lb</i>	<i>Sample Size</i>
FORWARD	38.2	20.2	86.0	47
BACKWARD	23.7	—	50.0	3

TABLE 20
COLLECTIVE: FORWARD FORCE

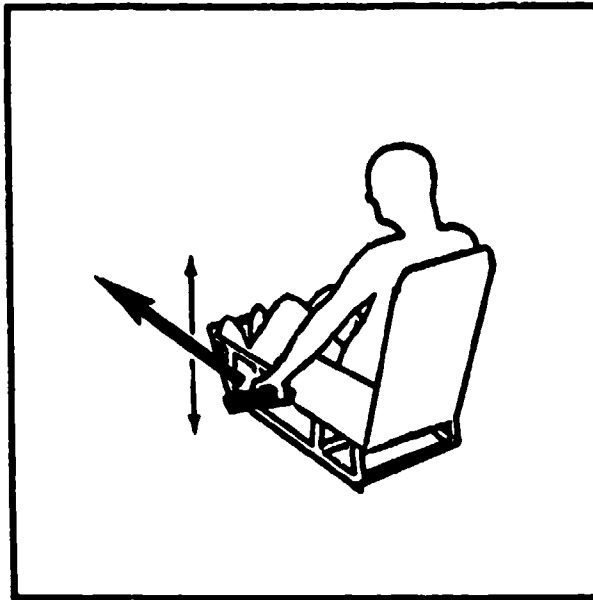

THE SUMMARY STATISTICS

<i>Newtons</i>		<i>Pounds</i>
298.8	Mean	67.1
10.0	SE (Mean)	2.3
71.4	SD	16.0
7.1	SE (SD)	1.6
Coef. of Var. (%)		23.9
Symmetry-Veta I		0.1
Kurtosis-Veta II		2.2
Number of Subj.		51

THE PERCENTILES

<i>Newtons</i>		<i>Pounds</i>
438.4	99th	98.5
419.1	95th	94.2
352.2	75th	79.2
296.1	50th	66.5
242.9	25th	54.6
184.2	5th	41.4
160.9	1st	36.2

The handle assembly is located 14 inches left of SRP, 4.75 inches above SRP, and 10.8 inches forward of SRP. The handle is oriented in the horizontal frontal plane and the subject grasps it from the top. The subject is instructed to exert a force in a horizontal plane in the forward direction.

**FORCE COMPONENTS RECORDED ORTHOGONALLY
TO THE REQUESTED DIRECTION**

	<i>Mean lb</i>	<i>SD lb</i>	<i>Maximum lb</i>	<i>Sample Size</i>
UP	15.5	—	21.0	2
DOWN	23.7	14.8	80.0	45

TABLE 21
COLLECTIVE: BACKWARD FORCE

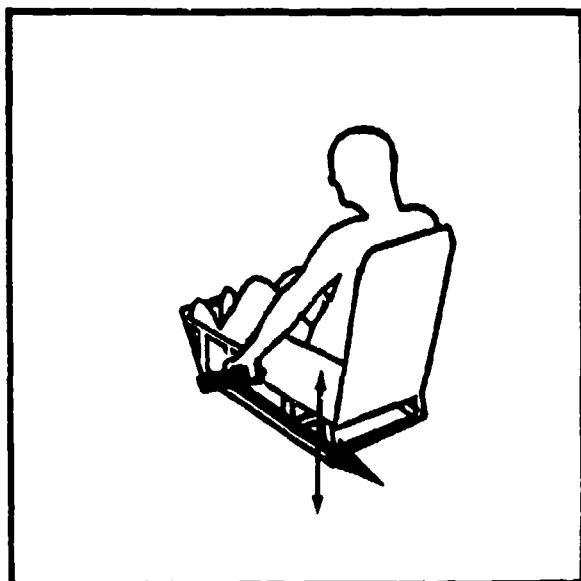

THE SUMMARY STATISTICS

<i>Newtons</i>		<i>Pounds</i>
261.9	Mean	58.9
7.2	SE (Mean)	1.6
51.5	SD	11.6
5.1	SE (SD)	1.2
Coef. of Var. (%)		19.7
Symmetry-Veta I		0.1
Kurtosis-Veta II		3.9
Number of Subj. 51		

THE PERCENTILES

<i>Newtons</i>		<i>Pounds</i>
378.8	99th	85.1
357.9	95th	80.4
289.7	75th	65.1
252.9	50th	56.8
231.8	25th	52.1
197.3	5th	44.3
119.0	1st	26.7

The handle assembly is located 14 inches left of SRP, 4.75 inches above SRP, and 10.3 inches forward of SRP. The handle is oriented in the horizontal frontal plane and the subject grasps it from the top. The subject is instructed to exert a force in a horizontal plane in the backward direction.

**FORCE COMPONENTS RECORDED ORTHOGONALLY
TO THE REQUESTED DIRECTION**

	<i>Mean lb</i>	<i>SD lb</i>	<i>Maximum lb</i>	<i>Sample Size</i>
UP	39.8	17.0	100.0	47
DOWN	16.3	—	25.0	3

TABLE 22
COLLECTIVE: LEFT FORCE

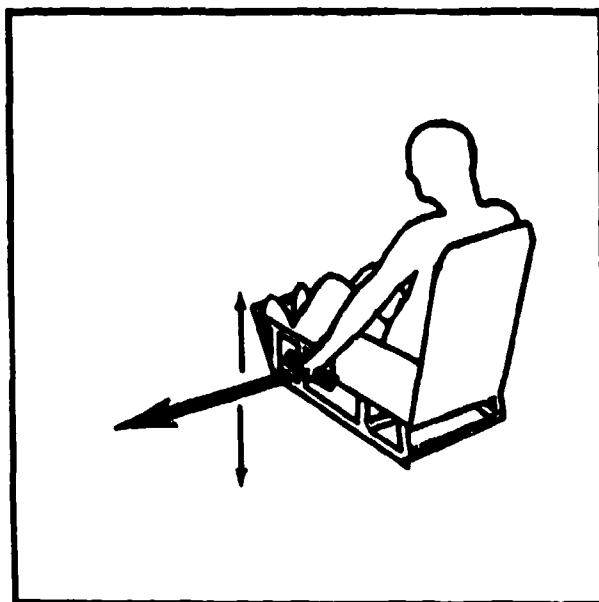

THE SUMMARY STATISTICS

<i>Newton</i>		<i>Pounds</i>
144.5	Mean	32.5
8.5	SE (Mean)	1.9
59.8	SD	13.4
6.0	SE (SD)	1.3
Coef. of Var. (%)		41.3
Symmetry-Veta I		0.6
Kurtosis-Veta II		3.1
Number of Subj. 50		

THE PERCENTILES

<i>Newton</i>		<i>Pounds</i>
315.9	99th	71.0
255.1	95th	57.3
181.0	75th	40.7
137.9	50th	31.0
101.0	25th	22.7
57.5	5th	12.9
32.8	1st	7.4

The handle assembly is located 14 inches left of SRP, 4.75 inches above SRP, and 10.3 inches forward of SRP. The handle is oriented in the horizontal sagittal plane and the subject grasps it from the left. The subject is instructed to exert a force in a horizontal plane in the left direction.

**FORCE COMPONENTS RECORDED ORTHOGONALLY
TO THE REQUESTED DIRECTION**

	<i>Mean lb</i>	<i>SD lb</i>	<i>Maximum lb</i>	<i>Sample Size</i>
UP	17.4	16.3	72.0	16
DOWN	28.8	17.9	70.0	26

TABLE 23
COLLECTIVE: RIGHT FORCE

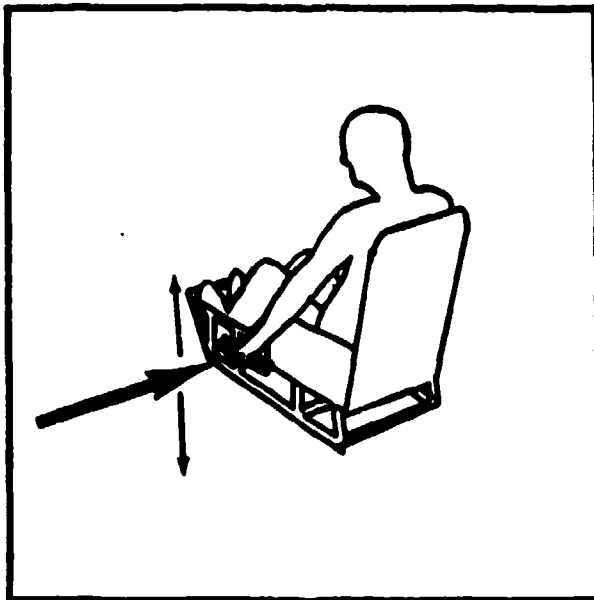

THE SUMMARY STATISTICS

<i>Newton</i>		<i>Pounds</i>
210.6	Mean	47.8
6.7	SE (Mean)	1.5
48.1	SD	10.8
4.8	SE (SD)	1.1
Coef. of Var. (%)		22.8
Symmetry: Veta I		0.2
Kurtosis: Veta II		2.8
Number of Subj.		51

THE PERCENTILES

<i>Newton</i>		<i>Pounds</i>
326.0	99th	73.8
290.6	95th	65.3
241.1	75th	54.2
208.1	50th	46.8
176.4	25th	39.6
132.8	5th	29.9
103.4	1st	23.2

The handle assembly is located 14 inches left of SRP, 4.75 inches above SRP, and 10.8 inches forward of SRP. The handle is oriented in the horizontal sagittal plane and the subject grasps it from the left. The subject is instructed to exert a force in a horizontal plane in the right direction.

**FORCE COMPONENTS RECORDED ORTHOGONALLY
TO THE REQUESTED DIRECTION**

	<i>Mean lb</i>	<i>SD lb</i>	<i>Maximum lb</i>	<i>Sample Size</i>
UP	41.5	27.8	100.0	38
DOWN	18.9	17.2	53.0	10

TABLE 24
COLLECTIVE: UP FORCE

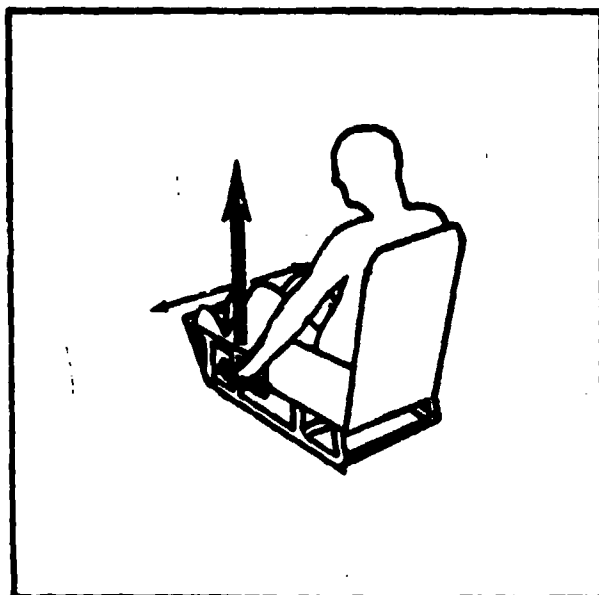

THE SUMMARY STATISTICS

<i>Newtons</i>		<i>Pounds</i>
379.2	Mean	85.2
11.5	SE (Mean)	2.6
81.8	SD	18.4
8.1	SE (SD)	1.8
Coef. of Var. (%)		21.6
Symmetry-Veta I		-0.3
Kurtosis-Veta II		3.0
Number of Subj. 51		

THE PERCENTILES

<i>Newtons</i>		<i>Pounds</i>
544.6	99th	122.4
510.7	95th	114.8
436.3	75th	98.1
380.7	50th	85.6
325.3	25th	73.1
236.9	5th	53.2
152.7	1st	34.3

The handle assembly is located 14 inches left of SRP, 4.75 inches above SRP, and 10.3 inches forward of SRP. The handle is oriented in the horizontal sagittal plane and the subject grasps it from the left. The subject is instructed to exert a force in a vertical plane in the up direction.

**FORCE COMPONENTS RECORDED ORTHOGONALLY
TO THE REQUESTED DIRECTION**

	<i>Mean lb</i>	<i>SD lb</i>	<i>Maximum lb</i>	<i>Sample Size</i>
LEFT	17.0	—	17.0	1
RIGHT	22.9	8.8	40.0	50

TABLE 25
COLLECTIVE: DOWN FORCE

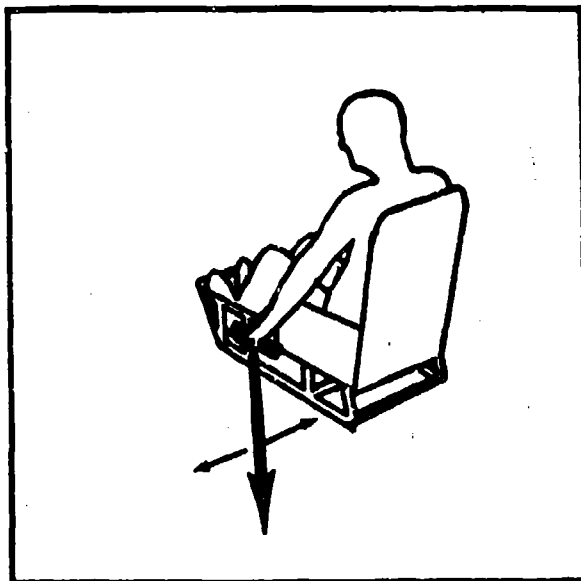

THE SUMMARY STATISTICS

<i>Newton</i>		<i>Pounds</i>
356.2	Mean	80.0
12.4	SE (Mean)	2.8
88.6	SD	19.9
8.8	SE (SD)	2.0
Coef. of Var. (%)		24.9
Symmetry-Veta I		-0.1
Kurtosis-Veta II		2.7
Number of Subj.		51

THE PERCENTILES

<i>Newton</i>		<i>Pounds</i>
550.5	99th	123.7
492.2	95th	110.6
416.9	75th	93.7
360.0	50th	80.9
296.9	25th	66.7
201.6	5th	45.3
143.2	1st	32.2

The handle assembly is located 14 inches left of SRP, 4.75 inches above SRP, 10.3 inches forward of SRP. The handle is oriented in the horizontal sagittal plane and the subject grasps it from the left. The subject is instructed to exert a force in a vertical plane in the down direction.

**FORCE COMPONENTS RECORDED ORTHOGONALLY
TO THE REQUESTED DIRECTION**

	<i>Mean lb</i>	<i>SD lb</i>	<i>Maximum lb</i>	<i>Sample Size</i>
LEFT	13.1	8.1	32.0	26
RIGHT	10.4	5.8	23.0	22

TABLE 26

OVERHEAD CONTROL: FORWARD FORCE

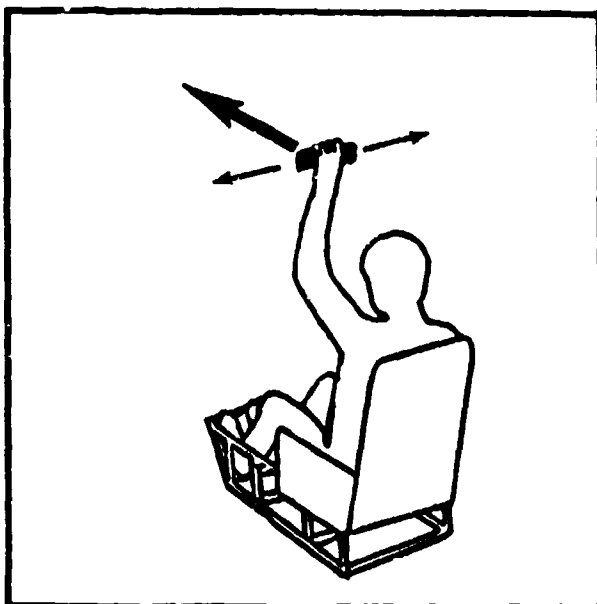

THE SUMMARY STATISTICS

<i>Newton</i> s		<i>Pound</i> s
144.4	Mean	32.5
6.5	SE (Mean)	1.5
46.5	SD	10.5
4.6	SE (SD)	1.0
	Coef. of Var. (%)	32.2
	Symmetry-Veta I	0.9
	Kurtosis-Veta II	4.1
	Number of Subj.	51

THE PERCENTILES

<i>Newton</i> s		<i>Pound</i> s
293.2	99th	65.9
230.4	95th	51.8
170.1	75th	38.2
139.4	50th	31.3
113.0	25th	25.4
78.7	5th	17.7
57.6	1st	12.9

The handle assembly is located 10 inches left of SRP, 47.3 inches above SRP, and 0.0 inches forward of SRP. The handle is oriented in the horizontal frontal plane and the subject grasps it from the back. The subject is instructed to exert a force in a horizontal plane in the forward direction.

FORCE COMPONENTS RECORDED ORTHOGONALLY TO THE REQUESTED DIRECTION

	<i>Mean lb</i>	<i>SD lb</i>	<i>Maximum lb</i>	<i>Sample Size</i>
UP	32.1	25.1	121.0	26
DOWN	20.9	17.2	62.0	22

TABLE 27
OVERHEAD CONTROL: BACKWARD FORCE

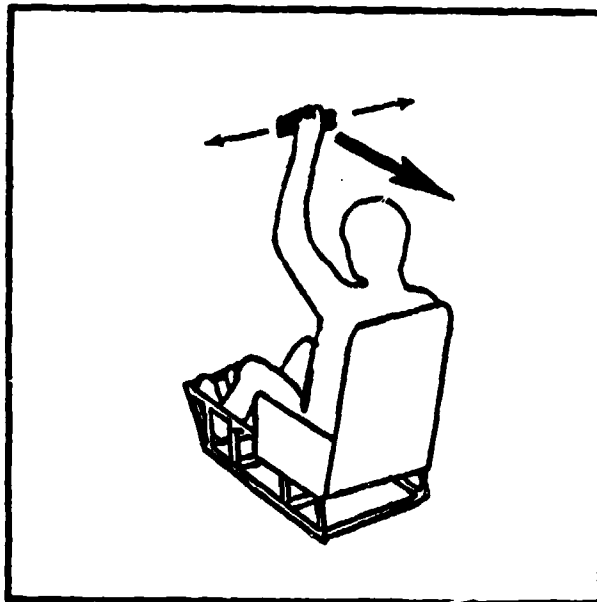

THE SUMMARY STATISTICS

<i>Newton's</i>		<i>Pounds</i>
82.6	Mean	18.6
2.9	SE (Mean)	0.7
20.9	SD	4.7
2.1	SE (SD)	0.5
Coef. of Var. (%)		25.3
Symmetry-Veta I		0.9
Kurtosis-Veta II		4.2
Number of Subj. 51		

THE PERCENTILES

<i>Newton's</i>		<i>Pounds</i>
146.2	99th	32.9
120.2	95th	27.0
92.6	75th	20.8
79.3	50th	17.8
69.0	25th	15.5
54.5	5th	12.2
39.7	1st	8.9

The handle assembly is located 10 inches left of SRP, 47.3 inches above SRP, and 0.0 inches forward of SRP. The handle is oriented in the horizontal frontal plane and the subject grasps it from the back. The subject is instructed to exert a force in a horizontal plane in the backward direction.

**FORCE COMPONENTS RECORDED ORTHOGONALLY
TO THE REQUESTED DIRECTION**

	<i>Mean lb</i>	<i>SD lb</i>	<i>Maximum lb</i>	<i>Sample Size</i>
UP	8.5	4.9	20.0	10
DOWN	21.7	18.0	78.0	39

TABLE 28

OVERHEAD CONTROL: LEFT FORCE

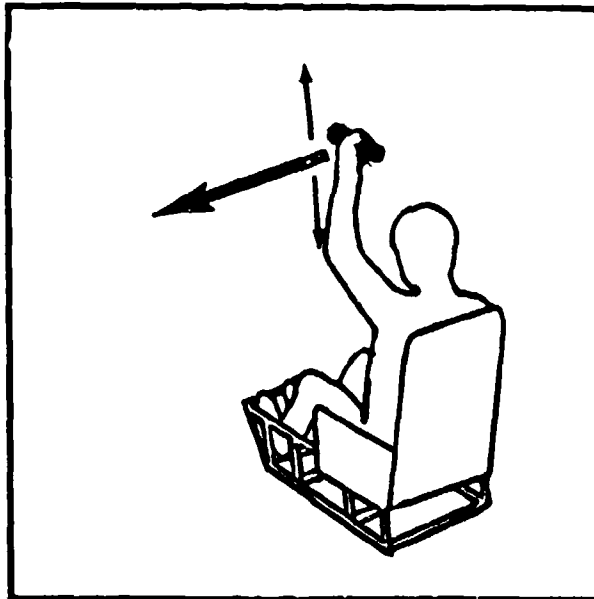

THE SUMMARY STATISTICS

<i>Newtons</i>		<i>Pounds</i>
115.2	Mean	25.9
4.8	SE (Mean)	1.1
93.9	SD	7.6
3.4	SE (SD)	0.8
Coef. of Var. (%)		29.5
Symmetry-Veta I		1.0
Kurtosis-Veta II		4.7
Number of Subj. 50		

THE PERCENTILES

<i>Newtons</i>		<i>Pounds</i>
226.3	99th	50.9
171.2	95th	38.5
131.5	75th	29.5
112.4	50th	25.3
92.9	25th	20.9
66.2	5th	14.9
59.4	1st	13.4

The handle assembly is located 10 inches left of SRP, 47.3 inches above SRP, and 0.0 inches forward of SRP. The handle is oriented in the horizontal sagittal plane and the subject grasps it from the left. The subject is instructed to exert a force in a horizontal plane in the left direction.

FORCE COMPONENTS RECORDED ORTHOGONALLY TO THE REQUESTED DIRECTION

	<i>Mean lb</i>	<i>SD lb</i>	<i>Maximum lb</i>	<i>Sample Size</i>
UP	14.2	10.5	44.0	22
DOWN	10.7	5.9	22.0	12

TABLE 29
OVERHEAD CONTROL: RIGHT FORCE

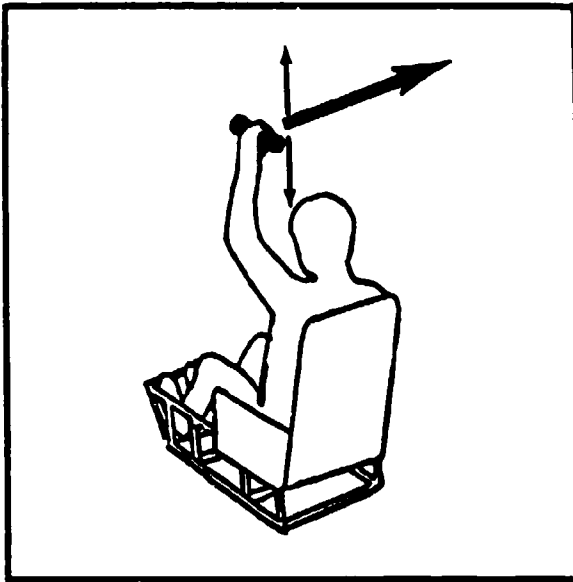

THE SUMMARY STATISTICS

<i>Newtons</i>		<i>Pounds</i>
112.2	Mean	25.2
4.6	SE (Mean)	1.0
32.6	SD	7.3
3.2	SE (SD)	0.7
Coef. of Var. (%)		29.1
Symmetry-Veta I		0.2
Kurtosis-Veta II		3.0
Number of Subj. 51		

THE PERCENTILES

<i>Newtons</i>		<i>Pounds</i>
190.4	99th	42.8
172.9	95th	38.9
133.3	75th	29.9
108.6	50th	24.4
89.8	25th	20.2
64.7	5th	14.6
33.9	1st	7.6

The handle assembly is located 10 inches left of SRP, 47.3 inches above SRP, and 0.0 inches forward of SRP. The handle is oriented in the horizontal sagittal plane and the subject grasps it from the left. The subject is instructed to exert a force in a horizontal plane in the right direction.

**FORCE COMPONENTS RECORDED ORTHOGONALLY
TO THE REQUESTED DIRECTION**

	<i>Mean lb</i>	<i>SD lb</i>	<i>Maximum lb</i>	<i>Sample Size</i>
UP	11.4	8.2	26.0	10
DOWN	33.5	20.7	88.0	38

TABLE 30
OVERHEAD CONTROL: UP FORCE

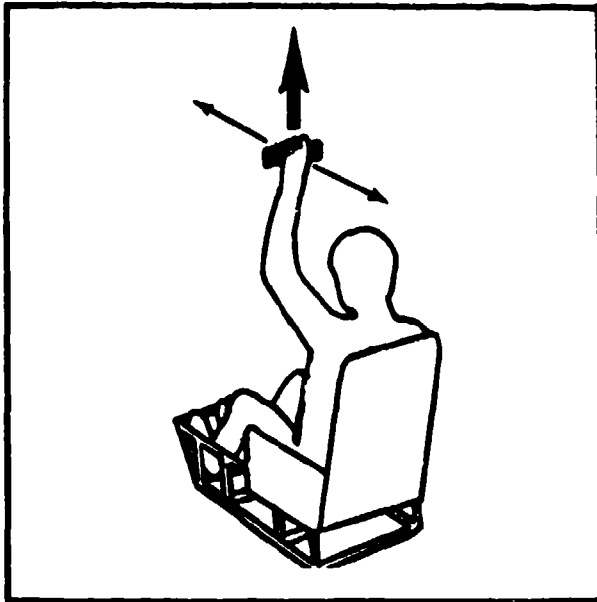

THE SUMMARY STATISTICS

<i>Newtons</i>		<i>Pounds</i>
780.9	Mean	175.5
33.7	SE (Mean)	7.6
240.6	SD	54.1
23.8	SE (SD)	5.4
Cof. of Var. (%)		30.8
Symmetry-Veta I		0.7
Kurtosis-Veta II		3.2
Number of Subj.		51

THE PERCENTILES

<i>Newtons</i>		<i>Pounds</i>
1899.1	99th	314.4
1255.5	95th	282.1
923.6	75th	207.6
733.2	50th	164.8
610.3	25th	137.1
479.4	5th	107.7
282.8	1st	63.6

The handle assembly is located 10 inches left of SRP, 47.3 inches above SRP, and 0.0 inches forward of SRP. The handle is oriented in the horizontal frontal plane and the subject grasps it from the back. The subject is instructed to exert a force in a vertical plane in the up direction.

**FORCE COMPONENTS RECORDED ORTHOGONALLY
TO THE REQUESTED DIRECTION**

	<i>Mean lb</i>	<i>SD lb</i>	<i>Maximum lb</i>	<i>Sample Size</i>
FORWARD	30.0	16.0	77.0	50
BACKWARD	21.0	--	21.0	1

TABLE 31
OVERHEAD CONTROL: DOWN FORCE

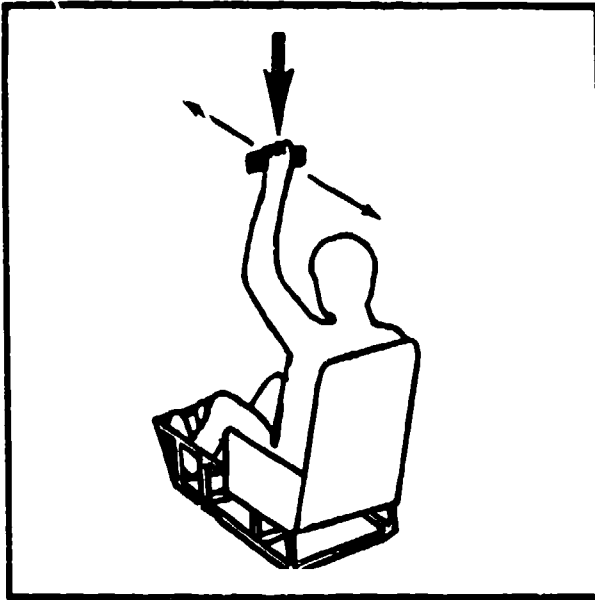

THE SUMMARY STATISTICS

<i>Newtons</i>		<i>Pounds</i>
438.5	Mean	98.6
9.1	SE (Mean)	2.1
65.1	SD	14.6
6.4	SE (SD)	1.5
Coef. of Var. (%)		14.8
Symmetry-Veta I		0.1
Kurtosis-Veta II		2.9
Number of Subj. 51		

THE PERCENTILES

<i>Newtons</i>		<i>Pounds</i>
591.0	99th	132.8
552.0	95th	124.1
480.6	75th	108.0
434.4	50th	97.6
394.9	25th	88.7
342.5	5th	77.0
294.8	1st	66.2

The handle assembly is located 10 inches left of SRP, 47.3 inches above SRP, and 0.0 inches forward of SRP. The handle is oriented in the horizontal frontal plane and the subject grasps it from the back. The subject is instructed to exert a force in a vertical plane in the down direction.

**FORCE COMPONENTS RECORDED ORTHOGONALLY
TO THE REQUESTED DIRECTION**

	<i>Mean lb</i>	<i>SD lb</i>	<i>Maximum lb</i>	<i>Sample Size</i>
FORWARD	8.6	5.4	21.0	35
BACKWARD	8.1	6.8	21.0	10

TABLE 32
PANEL CONTROL: FORWARD FORCE

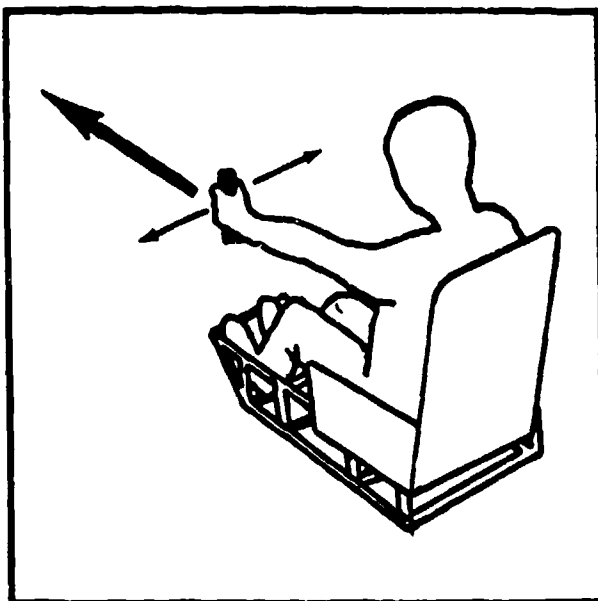

THE SUMMARY STATISTICS

<i>Newtons</i>		<i>Pounds</i>
755.7	Mean	169.8
22.6	SE (Mean)	5.1
161.6	SD	36.3
16.0	SE (SD)	3.6
Coef. of Var. (%)		21.4
Symmetry-Veta I		-0.5
Kurtosis-Veta II		3.2
Number of Subj. 51		

THE PERCENTILES

<i>Newtons</i>		<i>Pounds</i>
1090.6	99th	245.1
977.0	95th	219.6
867.0	75th	194.8
777.9	50th	174.8
661.3	25th	148.6
459.2	5th	103.2
321.7	1st	74.5

The handle assembly is located 10 inches left of SRP, 23 inches above SRP, and 24.7 inches forward of SRP. The handle is oriented vertically and the subject grasps it from the left. The subject is instructed to exert a force in a horizontal plane in the forward direction.

**FORCE COMPONENTS RECORDED ORTHOGONALLY
TO THE REQUESTED DIRECTION**

	<i>Mean lb</i>	<i>SD lb</i>	<i>Maximum lb</i>	<i>Sample Size</i>
LEFT	16.3	8.8	42.0	34
RIGHT	10.7	10.9	42.0	12

TABLE 33

PANEL CONTROL: BACKWARD FORCE

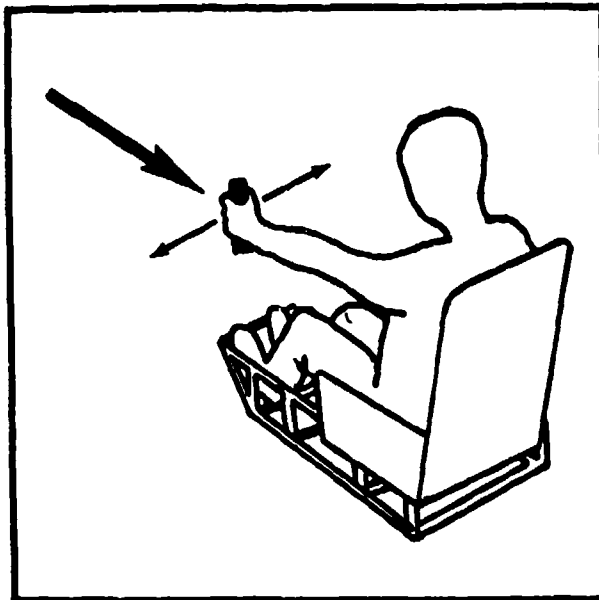

THE SUMMARY STATISTICS

<i>Newton</i> s		<i>Pound</i> s
497.4	Mean	111.8
12.2	SE (Mean)	2.7
87.0	SD	19.6
8.6	SE (SD)	1.9
	Coef. of Var. (%)	17.5
	Symmetry-Veta I	-0.1
	Kurtosis-Veta II	3.4
	Number of Subj.	51

THE PERCENTILES

<i>Newton</i> s		<i>Pound</i> s
722.9	99th	162.4
631.9	95th	142.0
552.1	75th	124.1
501.9	50th	112.8
448.0	25th	99.6
341.9	5th	76.8
272.9	1st	61.3

The handle assembly is located 10 inches left of SRP, 23 inches above SRP, and 24.7 inches forward of SRP. The handle is oriented vertically and the subject grasps it from the left. The subject is instructed to exert a force in a horizontal plane in the backward direction.

FORCE COMPONENTS RECORDED ORTHOGONALLY TO THE REQUESTED DIRECTION

	<i>Mean lb</i>	<i>SD lb</i>	<i>Maximum lb</i>	<i>Sample Size</i>
LEFT	6.0	3.2	12.0	9
RIGHT	9.5	6.0	28.0	40

TABLE 34

PANEL CONTROL: LEFT FORCE

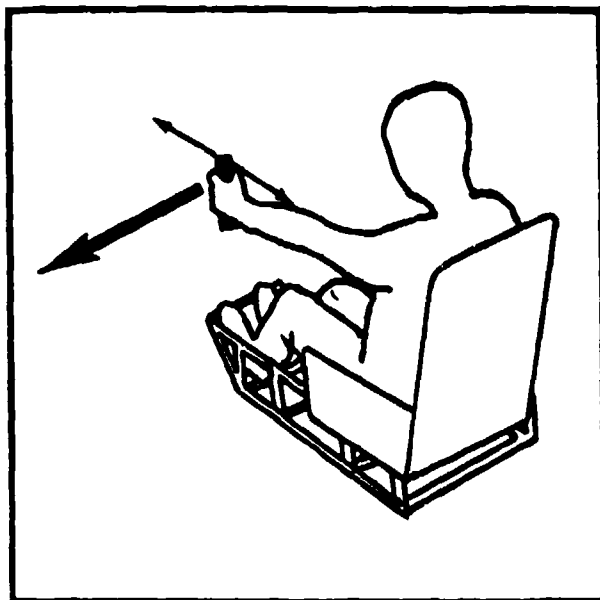

THE SUMMARY STATISTICS

<i>Newtons</i>		<i>Pounds</i>
101.6	Mean	22.8
4.2	SE (Mean)	1.0
29.8	SD	6.7
3.0	SE (SD)	0.7
Coef. of Var. (%)		29.4
Symmetry-Veta I		1.2
Kurtosis-Veta II		4.6
Number of Subj. 50		

THE PERCENTILES

<i>Newtons</i>		<i>Pounds</i>
201.2	99th	45.2
159.6	95th	35.9
115.7	75th	26.0
95.4	50th	21.4
81.2	25th	18.2
63.5	5th	14.3
45.3	1st	10.2

The handle assembly is located 10 inches left of SRP, 23 inches above SRP, and 24.7 inches forward of SRP. The handle is oriented vertically and the subject grasps it from the left. The subject is instructed to exert a force in a horizontal plane in the left direction.

FORCE COMPONENTS RECORDED ORTHOGONALLY TO THE REQUESTED DIRECTION

	<i>Mean lb</i>	<i>SD lb</i>	<i>Maximum lb</i>	<i>Sample Size</i>
FORWARD	20.7	21.0	84.0	17
BACKWARD	26.8	21.4	74.0	26

TABLE 35

PANEL CONTROL: RIGHT FORCE

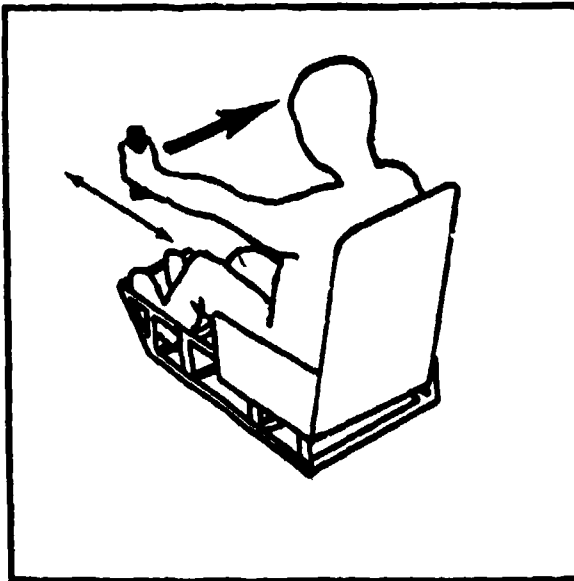

THE SUMMARY STATISTICS

<i>Newton</i>		<i>Pound</i>
155.9	Mean	35
5.1	SE (Mean)	1
36.7	SD	8
3.6	SE (SD)	0
	Coef. of Var. (%)	23
	Symmetry-Veta I	0
	Kurtosis-Veta II	2
	Number of Subj.	51

THE PERCENTILES

<i>Newton</i>		<i>Pound</i>
238.1	99th	53
221.9	95th	49
180.9	75th	40
152.6	50th	34
129.0	25th	29
101.6	5th	22
79.4	1st	17

The handle assembly is located 10 inches left of SRP, 23 inches above SRP, and 24.7 inches forward of SRP. The handle is oriented vertically and the subject grasps it from the left. The subject is instructed to exert a force in a horizontal plane in the right direction.

FORCE COMPONENTS RECORDED ORTHOGONALLY TO THE REQUESTED DIRECTION

	<i>Mean lb</i>	<i>SD lb</i>	<i>Maximum lb</i>	<i>Sample Size</i>
FORWARD	22.4	30.4	123.0	17
BACKWARD	24.9	17.3	75.0	27

TABLE 36
PANEL CONTROL: UP FORCE

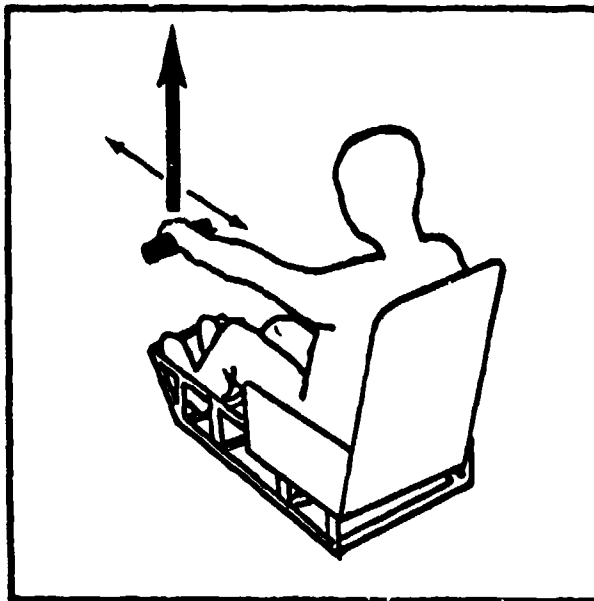

THE SUMMARY STATISTICS

<i>Newton</i> s		<i>Pound</i> s
107.5	Mean	24.2
3.4	SE (Mean)	0.8
24.8	SD	5.5
2.4	SE (SD)	0.6
Coef. of Var. (%)		22.6
Symmetry-Veta I		0.3
Kurtosis-Veta II		2.5
Number of Subj. 50		

THE PERCENTILES

<i>Newton</i> s		<i>Pound</i> s
161.5	99th	36.8
149.0	95th	33.5
123.4	75th	27.7
105.5	50th	23.7
89.9	25th	20.2
70.7	5th	15.9
56.7	1st	12.7

The handle assembly is located 10 inches left of SRP, 23 inches above SRP, and 24.7 inches forward of SRP. The handle is oriented in the horizontal frontal plane and the subject grasps it from the top. The subject is instructed to exert a force in a vertical plane in the up direction.

**FORCE COMPONENTS RECORDED ORTHOGONALLY
TO THE REQUESTED DIRECTION**

	<i>Mean lb</i>	<i>SD lb</i>	<i>Maximum lb</i>	<i>Sample Size</i>
FORWARD	26.7	21.2	69.0	14
BACKWARD	31.0	25.7	131.0	29

TABLE 37
PANEL CONTROL: DOWN FORCE

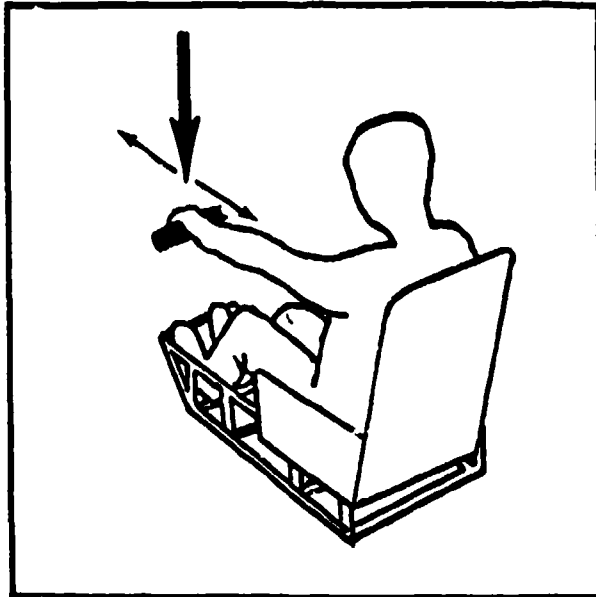

THE SUMMARY STATISTICS

<i>Newton's</i>		<i>Pounds</i>
180.0	Mean	40.4
6.4	SE (Mean)	1.4
44.9	SD	10.1
4.5	SE (SD)	1.0
	Coef. of Var. (%)	25.0
	Symmetry-Veta I	0.9
	Kurtosis-Veta II	4.4
	Number of Subj.	50

THE PERCENTILES

<i>Newton's</i>		<i>Pounds</i>
326.7	99th	73.4
254.9	95th	57.3
200.7	75th	45.1
175.9	50th	39.5
151.1	25th	34.1
115.3	5th	25.9
94.1	1st	21.2

The handle assembly is located 10 inches left of SRP, 23 inches above SRP, and 24.7 inches forward of SRP. The handle is oriented in the horizontal frontal plane and the subject grasps it from the top. The subject is instructed to exert a force in a vertical plane in the down direction.

**FORCE COMPONENTS RECORDED ORTHOGONALLY
TO THE REQUESTED DIRECTION**

	<i>Mean lb</i>	<i>SD lb</i>	<i>Maximum lb</i>	<i>Sample Size</i>
FORWARD	30.6	24.7	96.0	18
BACKWARD	22.3	13.6	59.0	24

TABLE 38

HATCH CONTROL: FORWARD FORCE

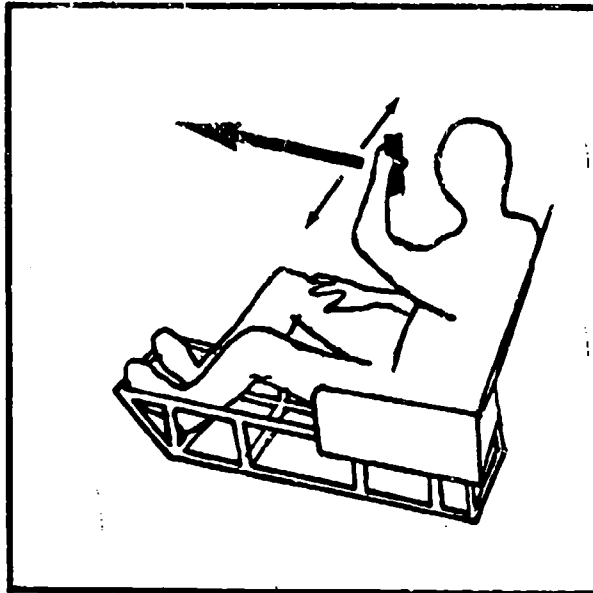

THE SUMMARY STATISTICS

<i>Newtons</i>		<i>Pounds</i>
155.7	Mean	35.0
7.8	SE (Mean)	1.7
55.4	SD	12.5
5.5	SE (SD)	1.2
Coef. of Var. (%)		35.6
Symmetry-Veta I		0.2
Kurtosis-Veta II		2.3
Number of Subj.		51

THE PERCENTILES

<i>Newtons</i>		<i>Pounds</i>
269.0	99th	60.4
252.6	95th	56.8
195.8	75th	44.0
151.4	50th	34.0
112.4	25th	25.3
71.9	5th	16.2
52.4	1st	11.8

The handle assembly is located 13 inches right of SRP, 23 inches above SRP, and 13 inches forward of SRP. The handle is oriented vertically and the subject grasps it from the left-front. The subject is instructed to exert a force in a horizontal plane in the forward direction.

FORCE COMPONENTS RECORDED ORTHOGONALLY
TO THE REQUESTED DIRECTION

	<i>Mean lb</i>	<i>SD lb</i>	<i>Maximum lb</i>	<i>Sample Size</i>
LEFT	5.1	1.8	8.0	11
RIGHT	14.9	13.6	57.0	34

TABLE 39

HATCH CONTROL: BACKWARD FORCE

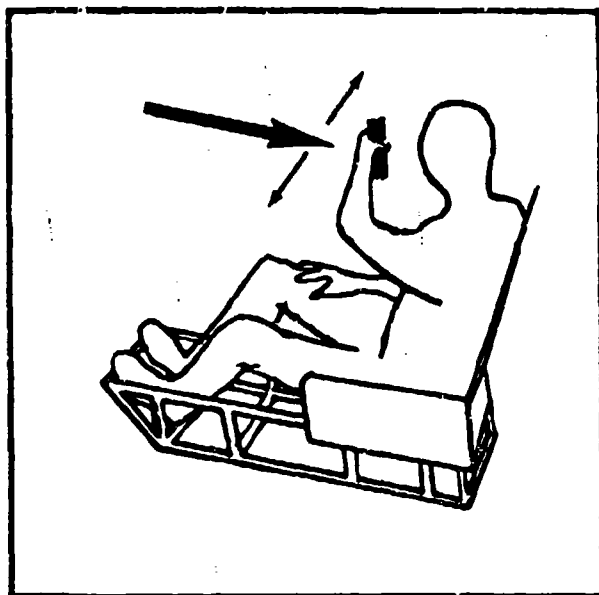

THE SUMMARY STATISTICS

<i>Newton</i>		<i>Pounds</i>
201.1	Mean	45.2
5.2	SE (Mean)	1.2
37.4	SD	8.4
3.7	SE (SD)	0.8
	Coef. of Var. (%)	18.6
	Symmetry-Veta I	0.3
	Kurtosis-Veta II	2.8
	Number of Subj.	51

THE PERCENTILES

<i>Newton</i>		<i>Pounds</i>
299.3	99th	67.3
266.7	95th	59.9
225.8	75th	50.8
199.1	50th	44.8
173.7	25th	39.0
142.9	5th	32.1
130.0	1st	29.2

The handle assembly is located 13 inches right of SRP, 23 inches above SRP, and 13 inches forward of SRP. The handle is oriented vertically and the subject grasps it from the left-front. The subject is instructed to exert a force in a horizontal plane in the backward direction.

**FORCE COMPONENTS RECORDED ORTHOGONALLY
TO THE REQUESTED DIRECTION**

	<i>Mean lb</i>	<i>SD lb</i>	<i>Maximum lb</i>	<i>Sample Size</i>
LEFT	33.0	15.1	67.0	47
RIGHT	19.3	—	45.0	8

TABLE 40

HATCH CONTROL: LEFT FORCE

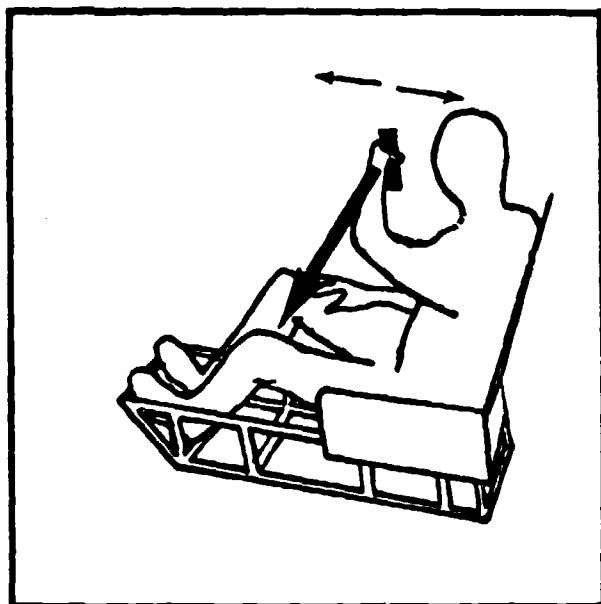

THE SUMMARY STATISTICS

<i>Newtons</i>		<i>Pounds</i>
320.1	Mean	71.9
8.7	SE (Mean)	2.0
62.0	SD	13.9
6.1	SE (SD)	1.4
Coef. of Var. (%)		19.4
Symmetry-Veta I		-0.4
Kurtosis-Veta II		3.1
Number of Subj. 51		

THE PERCENTILES

<i>Newtons</i>		<i>Pounds</i>
438.1	99th	98.4
415.9	95th	93.5
363.2	75th	81.6
321.7	50th	72.3
279.2	25th	62.7
211.8	5th	47.6
151.3	1st	34.0

The handle assembly is located 13 inches right of SRP, 23 inches above SRP, and 13 inches forward of SRP. The handle is oriented vertically and the subject grasps it from the left-front. The subject is instructed to exert a force in a horizontal plane in the left direction.

FORCE COMPONENTS RECORDED ORTHOGONALLY TO THE REQUESTED DIRECTION

	<i>Mean lb</i>	<i>SD lb</i>	<i>Maximum lb</i>	<i>Sample Size</i>
FORWARD	17.0	—	27.0	2
BACKWARD	21.3	10.8	47.0	49

TABLE 41
HATCH CONTROL: RIGHT FORCE

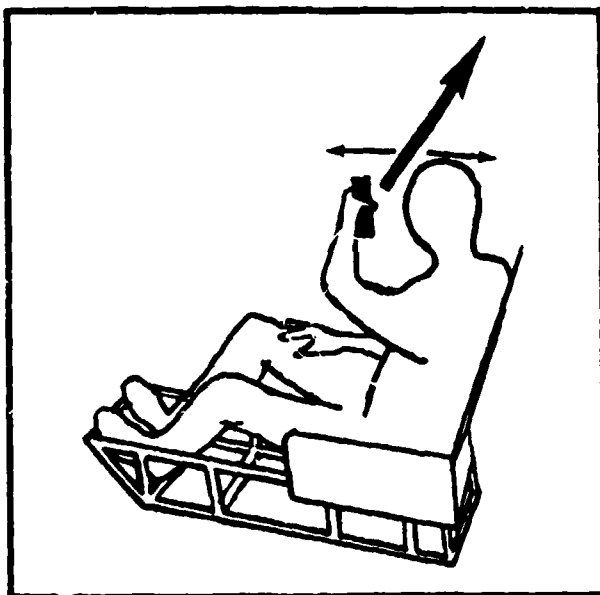

THE SUMMARY STATISTICS

<i>Newtons</i>		<i>Pounds</i>
253.1	Mean	56.9
9.0	SE (Mean)	2.0
64.6	SD	14.5
6.4	SE (SD)	1.4
Coef. of Var. (%)		25.5
Symmetry-Veta I		0.3
Kurtosis-Veta II		2.7
Number of Subj. 51		

THE PERCENTILES

<i>Newtons</i>		<i>Pounds</i>
414.2	99th	93.1
366.4	95th	82.3
297.1	75th	66.8
249.5	50th	56.1
204.8	25th	46.0
153.4	5th	34.5
134.0	1st	30.1

The handle assembly is located 13 inches right of SRP, 23 inches above SRP, and 13 inches forward of SRP. The handle is oriented vertically and the subject grasps it from the left-front. The subject is instructed to exert a force in a horizontal plane in the right direction.

**FORCE COMPONENTS RECORDED ORTHOGONALLY
TO THE REQUESTED DIRECTION**

	<i>Mean lb</i>	<i>SD lb</i>	<i>Maximum lb</i>	<i>Sample Size</i>
FORWARD	23.2	10.1	45.0	42
BACKWARD	12.5	—	20.0	4

TABLE 42

HATCH CONTROL: UP FORCE

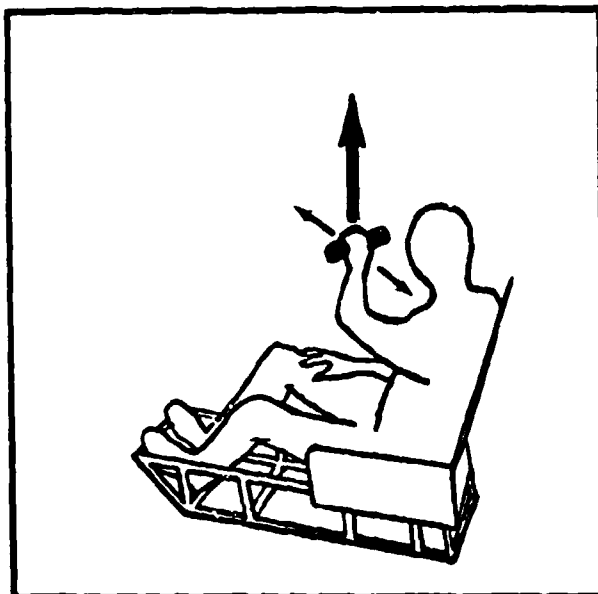

THE SUMMARY STATISTICS

<i>Newtons</i>		<i>Pounds</i>
124.8	Mean	28.0
5.7	SE (Mean)	1.3
40.9	SD	9.2
4.1	SE (SD)	0.9
Coef. of Var. (%)		32.8
Symmetry-Veta I		0.3
Kurtosis-Veta II		2.0
Number of Subj. 51		

THE PERCENTILES

<i>Newtons</i>		<i>Pounds</i>
202.4	99th	45.5
196.8	95th	44.2
156.0	75th	35.1
121.7	50th	27.3
91.8	25th	20.6
64.3	5th	14.5
56.1	1st	12.6

The handle assembly is located 13 inches right of SRP, 23 inches above SRP, and 13 inches forward of SRP. The handle is oriented horizontally and midway between a frontal and a sagittal orientation (accomplished by rotating the handle 45° clockwise from the horizontal frontal orientation). The subject grasps it from the top. The subject is instructed to exert a force in a vertical plane in the up direction.

FORCE COMPONENTS RECORDED ORTHOGONALLY TO THE REQUESTED DIRECTION

	<i>Mean lb</i>	<i>SD lb</i>	<i>Maximum lb</i>	<i>Sample Size</i>
FORWARD	28.5	16.3	61.0	12
BACKWARD	27.9	15.8	62.0	36

TABLE 43
HATCH CONTROL: DOWN FORCE

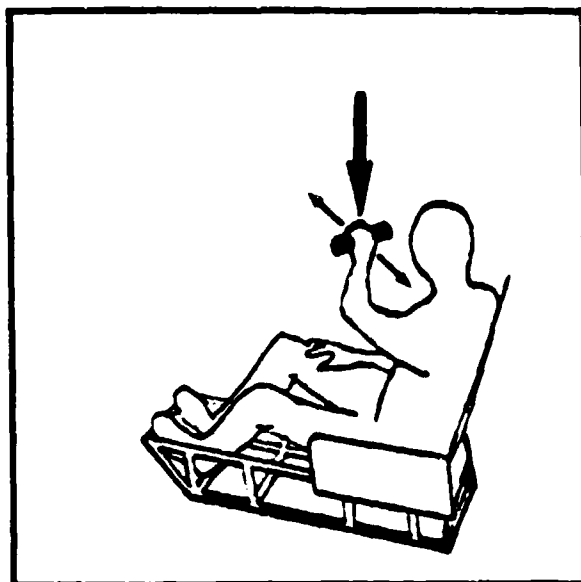

THE SUMMARY STATISTICS

<i>Newtons</i>		<i>Pounds</i>
187.3	Mean	42.1
4.8	SE (Mean)	1.1
34.0	SD	7.6
3.4	SE (SD)	0.8
Coef. of Var. (%)		18.1
Symmetry-Veta I		0.1
Kurtosis-Veta II		3.6
Number of Subj. 51		

THE PERCENTILES

<i>Newtons</i>		<i>Pounds</i>
278.7	99th	62.6
234.5	95th	52.7
207.6	75th	46.7
190.6	50th	42.8
166.4	25th	37.4
124.4	5th	28.0
106.8	1st	24.0

The handle assembly is located 13 inches right of SRP, 23 inches above SRP, and 13 inches forward of SRP. The handle is oriented horizontally and midway between a frontal and a sagittal orientation (accomplished by rotating the handle 45° clockwise from the horizontal frontal orientation). The subject grasps it from the top. The subject is instructed to exert a force in a vertical plane in the down direction.

**FORCE COMPONENTS RECORDED ORTHOGONALLY
TO THE REQUESTED DIRECTION**

	<i>Mean lb</i>	<i>SD lb</i>	<i>Maximum lb</i>	<i>Sample Size</i>
FORWARD	15.1	7.6	29.0	13
BACKWARD	22.7	14.2	60.0	33

TABLE 44

**HATCH CONTROL: FORWARD FORCE
(ROTATED 45° CLOCKWISE)**

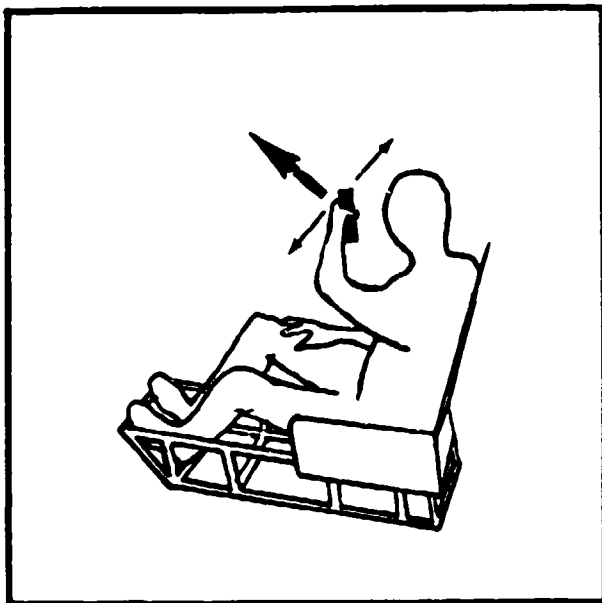

THE SUMMARY STATISTICS

<i>Newton</i>		<i>Pounds</i>
410.0	Mean	92.1
9.7	SE (Mean)	2.2
69.4	SD	15.6
6.9	SE (SD)	1.6
	Coef. of Var. (%)	16.9
	Symmetry-Veta I	-0.3
	Kurtosis-Veta II	3.6
	Number of Subj.	51

THE PERCENTILES

<i>Newton</i>		<i>Pounds</i>
566.6	99th	127.3
514.0	95th	115.5
453.4	75th	101.9
412.3	50th	92.7
366.0	25th	82.3
283.1	5th	63.6
210.6	1st	47.3

The handle assembly is located 13 inches right of SRP, 23 inches above SRP, and 13 inches forward of SRP. The handle is oriented vertically and the subject grasps it from the left-front. The subject is instructed to exert a force in a horizontal plane in a direction which extends out at an angle of 45° clockwise from forward.

**FORCE COMPONENTS RECORDED ORTHOGONALLY
TO THE REQUESTED DIRECTION**

	<i>Mean lb</i>	<i>SD lb</i>	<i>Maximum lb</i>	<i>Sample Size</i>
LEFT	4.9	2.9	12.0	9
RIGHT	10.4	5.3	22.0	37

TABLE 45
HATCH CONTROL: BACKWARD FORCE
(ROTATED 45° CLOCKWISE)

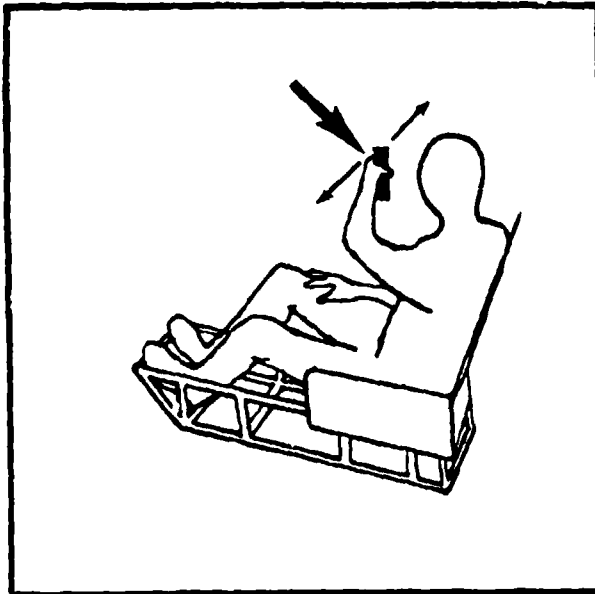

THE SUMMARY STATISTICS

<i>Newtons</i>		<i>Pounds</i>
386.0	Mean	86.8
9.2	SE (Mean)	2.1
65.9	SD	14.8
6.5	SE (SD)	1.5
Coef. of Var. (%)		17.1
Symmetry-Veta I		-0.3
Kurtosis-Veta II		4.5
Number of Subj. 51		

THE PERCENTILES

<i>Newtons</i>		<i>Pounds</i>
537.7	99th	120.8
501.1	95th	112.6
422.9	75th	95.0
380.6	50th	85.5
351.3	25th	78.9
295.3	5th	66.4
194.2	1st	43.6

The handle assembly is located 13 inches right of SRP, 23 inches above SRP, and 13 inches forward of SRP. The handle is oriented vertically and the subject grasps it from the left-front. The subject is instructed to exert a force in a horizontal plane in a direction which extends out at an angle 45° clockwise from backward.

**FORCE COMPONENTS RECORDED ORTHOGONALLY
TO THE REQUESTED DIRECTION**

	<i>Mean lb</i>	<i>SD lb</i>	<i>Maximum lb</i>	<i>Sample Size</i>
LEFT	19.4	6.9	34.0	46
RIGHT	9.5	—	17.0	2

TABLE 46

**HATCH CONTROL: LEFT FORCE
(ROTATED 45° CLOCKWISE)**

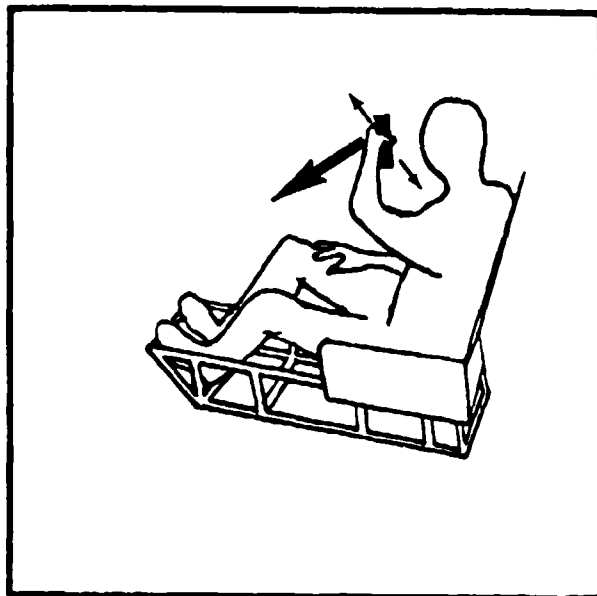

THE SUMMARY STATISTICS

<i>Newtons</i>		<i>Pounds</i>
171.5	Mean	38.6
5.9	SE (Mean)	1.3
42.2	SD	9.5
4.2	SE (SD)	0.9
Coef. of Var. (%)		24.6
Symmetry-Veta I		1.0
Kurtosis-Veta II		5.8
Number of Subj. 51		

THE PERCENTILES

<i>Newtons</i>		<i>Pounds</i>
331.0	99th	74.4
241.4	95th	54.2
190.6	75th	42.8
170.8	50th	38.4
147.1	25th	33.1
105.3	5th	23.7
87.7	1st	19.7

The handle assembly is located 13 inches right of SRP, 23 inches above SRP, and 13 inches forward of SRP. The handle is oriented vertically and the subject grasps it from the left-front. The subject is instructed to exert a force in a horizontal plane in a direction which extends out at an angle 45° clockwise from left.

**FORCE COMPONENTS RECORDED ORTHOGONALLY
TO THE REQUESTED DIRECTION**

	<i>Mean lb</i>	<i>SD lb</i>	<i>Maximum lb</i>	<i>Sample Size</i>
FORWARD	5.0	—	7.0	2
BACKWARD	25.6	14.6	67.0	44

TABLE 47
HATCH CONTROL: RIGHT FORCE
(ROTATED 45° CLOCKWISE)

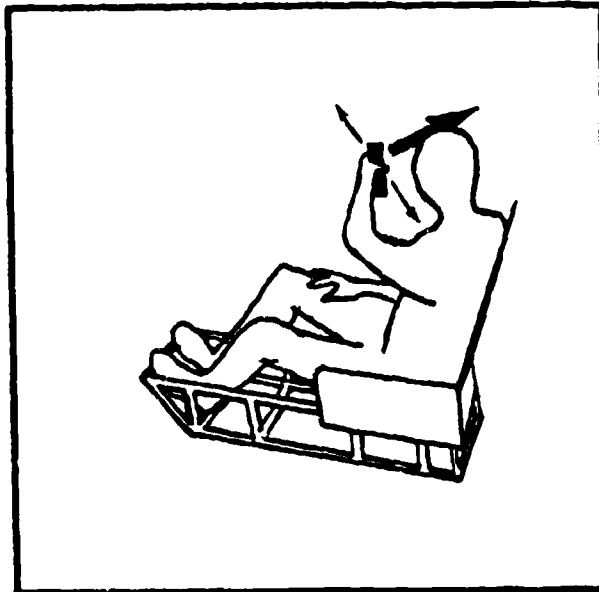

THE SUMMARY STATISTICS

<i>Newton's</i>		<i>Pounds</i>
169.5	Mean	38.1
6.1	SE (Mean)	1.4
48.8	SD	9.8
4.8	SE (SD)	1.0
Coef. of Var. (%)		25.8
Symmetry-Veta I		0.5
Kurtosis-Veta II		2.9
Number of Subj. 51		

THE PERCENTILES

<i>Newton's</i>		<i>Pounds</i>
289.5	99th	65.1
245.2	95th	55.1
196.7	75th	44.2
166.2	50th	37.4
137.3	25th	30.8
104.4	5th	23.5
97.6	1st	21.9

The handle assembly is located 13 inches right of SRP, 23 inches above SRP, and 13 inches forward of SRP. The handle is oriented vertically and the subject grasps it from the left-front. The subject is instructed to exert a force in a horizontal plane in a direction which extends out at an angle 45° clockwise from right.

**FORCE COMPONENTS RECORDED ORTHOGONALLY
TO THE REQUESTED DIRECTION**

	<i>Mean lb</i>	<i>SD lb</i>	<i>Maximum lb</i>	<i>Sample Size</i>
FORWARD	22.7	15.0	75.0	27
BACKWARD	11.1	8.9	24.0	16

SECTION VII

DISCUSSION OF THE RESULTS

Comparison with the Results of Other Studies

The data presented in this study deal with maximal ("peak") forces attainable in simulated aircraft control locations. Studies by Hunsicker (1955, 1957) and Watt (1968) are similar to this study in concept; however, their data are not comparable for the following reasons:

- Hunsicker's maximal force was achieved by taking three readings of three force components (X, Y, and Z directions of which one was the requested direction) during a 5-second exertion period. The resultant forces were calculated and the largest reported.
- Hunsicker had two positions (elbow flexion of 120° and 180°) that were somewhat similar in location to two positions examined in this study (Throttle and Panel Control). The positions Hunsicker examined were designed to achieve specific degrees of elbow flexion on the subjects, while the positions in this study were concerned with being a specific distance from SRP, regardless of the elbow flexion angle. Since the criteria that determine the positions for the two studies were different, it is not safe to assume they supply comparable data.
- Watt did not state clearly what type of maximal force he reported. Kroemer and Howard (1970) showed that under certain conditions, substantially different "maximal" forces can be extracted from the same force curves.
- Watt studied a stick-type control located "20 inches from SRP." Watt's stick was located approximately 85% farther from SRP than the stick in this study. Such a difference in location brings about significant biomechanical differences and results in different force data.

Effects of Handle Location and Exertion Direction on the Magnitude of Force

Depending on the location of the handle and on the requested direction of the force to be exerted, the amounts of force recorded vary greatly. Generally, low forces were observed in directions about perpendicular to the line from the subject's left shoulder to the handle, especially if the control location required extension of the arm. Rather large forces could be exerted approximately along the line between the shoulder and handle, especially if the extended arm could be locked between the opposing surfaces of the seat and handle. In that position a toggle effect was possible that allowed very high forces; see, for example, Panel Control, Forward Force and Overhead Control, Up Force.

Even for a given location of the handle, the forces measured in different directions can vary greatly. For example, the Up Force at the Overhead Control is extremely large, while the Backward Force exerted at the same control is among the smallest observed. This shows that no control location can be generally labeled as being well (or badly) suited for large force exertions without specifying the direction of force exertion.

Component Forces

Tables 4 through 47 list, in addition to the forces exerted in the requested direction, the forces recorded in orthogonal directions. These components do not necessarily constitute the largest possible orthogonal forces for two reasons: (1) the subjects were not controlled with respect to the amount of orthogonal forces exerted, and (2) out of a multitude of directions "orthogonal" to the requested direction, only selected ones were monitored.

While it cannot be claimed that maximal possible components were observed, the magnitude of such component forces recorded in a number of cases reaches or exceeds the amount of force exerted in the requested direction (e.g., Throttle, Left; Overhead Control, Forward; Overhead Control, Backward; Overhead Control, Right; Panel Control, Left; Panel Control, Up; Hatch Control, Up).

Relatively large forces in "undesired" directions seem to occur mainly if only rather

small forces could be exerted in the requested directions. Here, the muscles of the operator contract under mechanically disadvantageous conditions with respect to the requested output while exertions in orthogonal directions may be more effective (e.g., Panel Control, Left, as compared to Panel Control, Forward and Backward).

Even without further discussion of biomechanical implications it should be clear to the designer that he may have to consider rather large forces being applied to controls in directions different from the direction of primary operation.

Mode of Operation

Backward force in the Stick position was exerted in three different ways: in a one-handed pull, in a one-handed inward push where the elbow was swung forward and the operator pushed towards his trunk, and in a two-handed pull. Both one-handed exertions yielded approximately the same values, although the inward push was numerically somewhat weaker than the pull. The two-handed pull resulted in substantially larger forces recorded. While this result does not substantiate the claim sometimes heard that the inward push allows larger "aft-force at the stick" in critical flight maneuvers, it does support the reports of pilots that "pulling back with both hands" allows larger forces at the stick in the full aft positions than one-handed pulls. The substantial increases in force while using two hands instead of one hand are in accordance with gains found by Watt (1963) and by Hertzberg (reported in Damon, Stoudt, and McFarland, 1966, pp. 223-225). The increases generally range from one-third to three-fourths.

At the Throttle (Sidearm Controller), Forward as well as Backward forces were exerted at the handle, which was oriented vertically as well as horizontally. The magnitude of forces exertable in each direction did not seem to depend significantly on the handle orientation used.

Correlations Among Measurements

In general, the correlations among forces as well as between forces and anthropometric variables are rather low, as indicated in Appendices III and IV. Among the force measurements only a few high correlations were observed.

On the Stick, the Backward, two-hand exertion correlation was high (0.79) with the Backward, one-hand exertion. At the same time, the Backward, inward push correlation was low with both the Backward, one-hand pull and the Backward, two-hand pull (0.24 and 0.28 respectively).

On the Throttle (Sidearm Controller), the two methods of Forward and Backward exertion (handle vertical and horizontal) correlated highly. The two forward forces correlated at 0.73 while the backward forces reached 0.92, the highest correlation found.

Only seventeen exertion pairs had coefficients of correlation of 0.70 or better. This is a small fraction of the total number of exertion pairs (946) and indicates that correlations are not very useful in predicting force capabilities. If information is desired on forces exertable in locations or directions other than those previously reported, the information generally has to be gathered experimentally rather than computed from other force data.

Anthropometric and strength measurement correlation coefficients also yielded low values. A similar lack of high correlation coefficients among measurements of strength and anthropometric variables has been shown in earlier publications (Laubach and McConville, 1966 and 1969; Kroemer and Robinson 1971).

SECTION VIII

SUMMARY AND CONCLUSIONS

This report contains experimental data on the maximal static forces that male subjects (n=51) could exert at six locations of hand-operated aircraft controls, in two vertical and four to eight horizontal directions.

The results show that the amount of force exerable depends decidedly on the location of the aircraft control and on the directions of force exertion. None of the six control locations is equally or uniformly suited for exertions of very large forces in all directions. Similarly, none of the directions of force exertion used in this study allows application of very large forces in all control locations.

In all of the locations, smaller forces were generally exerted in directions perpendicular to a line passing from the handle location to the shoulder of the arm used, while larger forces were usually recorded in directions along that line.

Correlations among forces and anthropometric dimensions were generally too low to have practical prediction value.

The force data apply to the static condition, in which muscles are contracted isometrically, i.e., without changes in length. In this condition, no motion takes place between the operator and the control to which he applies force. Hence the designer is cautioned against the indiscriminate use of data on static muscle strength for dynamic work. However, static force data may be used for conservative estimates of the "break-away force" to be applied initially to an object to set it in motion. They are also of value if a force must be sustained over a period of time, and may (with caution) be applied to very slow motions (Kroemer 1970).

Forty-four individual data pages (tables 4-47) show in detail selected descriptive statistics for each of the 44 force exertion measurements. The magnitude and direction of force components perpendicular to the requested direction are also presented. These data should aid the design engineer in the selection and arrangement of primary aircraft controls.

APPENDIX I

DESCRIPTIONS OF ANTHROPOMETRIC MEASUREMENTS AND GRIP STRENGTH

Weight—The subject, lightly clad, removes his shoes and heavy contents of pockets and steps on the scale. The scale is read to the nearest half kilogram.

Stature—Shoes removed, the subject stands erect looking directly forward (head oriented in the Frankfort plane). With the anthropometer arm firmly touching the scalp, measure the vertical distance from the standing surface to the top of the head.

Sitting Height—Subject sits erect looking directly forward (head oriented in Frankfort plane). With the anthropometer arm firmly touching the scalp, measure the vertical distance from the sitting surface to the top of the head.

Thumb-Tip Reach—Subject stands erect with heels, buttocks, shoulder blades and head in contact with a vertical surface. His right arm is extended forward and perpendicular to the vertical surface, the tip of his index finger touching the tip of the extended thumb, the thumb in the plane of the extended arm. Using the anthropometer, measure the horizontal distance from the vertical surface to the tip of the thumb.

Lateral Thumb-Tip Reach—Subject stands erect with his side towards a vertical surface, his left shoulder touching the wall. His right arm is extended laterally and perpendicular to the vertical surface, the tip of his index finger touching the tip of the extended thumb, the thumb in the plane of the extended arm. Using the anthropometer, measure the horizontal distance from the vertical surface to the tip of the thumb.

Grip Strength—Subject stands relaxed. He is instructed to place the Smedley dynamometer in his preferred hand, adjust the grip width to suit himself and squeeze the dynamometer as hard as possible. The peak force achieved is read to the nearest kilopond. Three trials are administered with approximately 2 minutes between trials.

APPENDIX II

STATISTICAL PROCEDURES AND TERMINOLOGY

The statistical measures selected to summarize the experimental data were chosen as the ones which we hope will provide most potential users with the maximum of useful information.

Briefly described, these statistics are:

The arithmetic mean. This is the most common of the averages and is computed as the sum of the values divided by the number of values. In formula, the mean equals

$$\bar{x} = \frac{\Sigma x}{n}$$

where Σ is the summation operator, x represents the individual values, and n is the number of values. The mean is designated by \bar{x} or mean in this study.

The standard deviation. The standard deviation is the basic measure of variability. If most of a set of data cluster close to their mean value, the standard deviation will be small. If, on the other hand, many of the data are either much smaller or much larger than the mean, the standard deviation will be large. By definition, the standard deviation is the square root of the average (i.e., arithmetic mean) of the squared deviations from the mean value. In formula, the standard deviation equals

$$SD = \sqrt{\Sigma(x-\bar{x})^2/n}$$

where Σ is the summation operator, x represents the individual values, \bar{x} their arithmetic mean, and n the number of values.

A useful way of conceptualizing the standard deviation is to consider the middle two-thirds of a set of data such as the values of stature. The smallest value in this middle two-thirds will be about one standard deviation below the mean value and the largest value in this set will be roughly equal to the mean value plus one standard deviation. Similarly, the middle 95 percent of the data will have values ranging from approximately two standard deviations below the mean to two standard deviations above it. Almost all of them will fall within the range from three standard deviations below the mean to three standard deviations above it. The standard deviation is designated by SD in this study.

The standard errors. All statistics computed from a sample of data are subject to the effects of sampling error. When a sample has been selected by a random or other probability sampling process, it is often possible to estimate the magnitude of the sampling error. For many statistics, this estimate takes the form of the standard error of that statistic. The standard error is a standard deviation type statistic and is such that, were a large number of samples of data selected in the same way from the same population, about two-thirds of the samples would have means (or standard deviations or percentiles or whatever) with values which lie within a standard error of the corresponding population statistic, 95% within two standard errors, and so forth. Hence, it is conventional to suppose, when dealing with the statistics computed from a single sample, that the population statistics may well be within a standard error—up or down—of the corresponding sample statistics, and that it is rather likely that they are within two standard errors.

Each statistic has its own standard error, the value of which depends on the statistic, on the sample size, and, often, on the standard deviation of the data. The standard errors of the most common statistics (except that of the range) are, for the large samples inversely proportional in size to the square root of the sample size.

For each variable, the standard error of the mean ($= SD/\sqrt{n}$) and that of the standard deviation ($= SD/\sqrt{2n}$) are listed. The standard errors of the other statistics reported on here can be determined from the following formulas:

<i>Statistic</i>	<i>Standard Error</i>
50th percentile	1.3 SE of the mean
25th & 75th percentiles	1.4 SE of the mean
5th & 95th percentiles	2.1 SE of the mean
1st & 99th percentiles	3.7 SE of the mean
Coefficient of Variation	$V/\sqrt{2n}$
Veta I	$\sqrt{6/n}$
Veta II	$\sqrt{24/n}$

The standard error of the mean is designated as SE (Mean) and the standard error of the standard deviation is designated as SE (SD).

The coefficient of variation. This statistic is a restatement of the standard deviation as a percent of the mean, and it is usually denoted by the letter V. Thus,

$$V = 100 \text{ SD}/\bar{x}$$

Veta I—a measure of symmetry. The statistic β_1 is based on the fact that in a symmetric distribution every value lying a given distance above the mean will be matched by a value lying an equal distance below the mean, so that the cubes of the deviations from the mean—half negative and half positive—will add to zero. Although the converse of this fact is by no means true—a zero sum of the cubed deviations in no way implies a symmetric distribution—the size of this sum when properly adjusted is often considered a useful indication of whether a set of data is unsymmetrically distributed and, if so, how badly.

Veta I is computed from the sum of the cubed deviations by dividing it by the sample size and the cube of the standard deviation, producing a dimensionless statistic:

$$\beta_1 = \frac{\sum(x - \bar{x})^3}{n \cdot \text{SD}^3}$$

Veta II—a measure of kurtosis. The statistic β_2 is similarly computed from the fourth powers of the deviations:

$$\beta_2 = \frac{\sum(x - \bar{x})^4}{n \cdot \text{SD}^4}$$

The interpretation of β_2 is not obvious; its major value, along with β_1 , is that its value provides a basis for judging the level of agreement between the normal distribution and the actual distribution of the data.

The normal distribution values for β_1 and β_2 are 0 and 3.

When we have occasion to spell out the symbol 'β' we have used 'Veta' in accordance with contemporary Greek pronunciation.

The range. The range is simply the maximum and minimum scores.

The percentiles. This group of statistics belongs to a class of measures designated as "measures of order or position". These measures can be thought of as being obtained by arranging the data in order from the smallest value to the largest one and then observing the value of the datum which lies at a specified position in the array.

Perhaps the most useful of these statistics are the percentiles. The 99 percentiles—ranging from the 1st to the 99th—are the values at the points which separate consecutive blocks or units of 1% of the data in the ordered array. The first percentile is the value which separates the smallest 1% of the data from the 99% of the data with larger values; the fifth percentile separates the smallest 5% from the larger 95% and so on.

The percentiles were computed using the textbook method—that is, the K-th raw percentile, P (K), is computed by locating the first interval in the frequency table in which the cumulative percent frequency equals or exceeds K%:

$$P(K) = LL + \frac{K - \text{CPF}(J-1)}{\text{CPF}(J) - \text{CPF}(J-1)} \text{WID}$$

where LL is the lower limit of this interval, CPF(J) the cumulative percent frequency including this interval, CPF(J-1) the cumulative percent frequency up to but not including this interval, and WID is the interval width.

The seven computed percentiles were then smoothed by a process designed to simulate plotting them on normal probability graph paper and drawing a smooth line through the set of points. What is actually done is to assign an 'X-value' to each raw percentile equal to the corresponding deviate of the normal distribution, fit a fourth degree polynomial to these points, and read the smoothed values from this polynomial. Because of the smoothing process it is possible for the first and ninety-ninth percentiles to exceed the range of the data (e.g., see Overhead Control: Up Force—

1%ile = 63.6 lbs.
 99%ile = 314.4 lbs
 range = 65 lbs to 308 lbs).

The correlation coefficients. The correlation coefficient describes the degree of relationship between two or more variables. The most common statistical measure of such relationships is the Pearsonian product-moment correlation coefficient (usually designated by the letter "r"). The correlation coefficient varies, in numerical value, from 0.0 to 1.0. Values of 0.0 indicate no relationship and those of 1.0 indicate perfect relationships. Positive values of these coefficients indicate that large values of one member of a pair of variables tend to occur simultaneously with large values of the other, and that small values of one tend to occur along with small values of the other. Negative values indicate the reverse: small values of one variable being associated, in general, with large values of the other. The degree of association is independent of the sign of the coefficient; a correlation of -0.50 and one of +0.50 represent the same intensity of relationship.

In formula, the Pearson product-moment correlation equals

$$r = \frac{n\sum xy - \sum x \sum y}{\sqrt{[n\sum x^2 - (\sum x)^2][n\sum y^2 - (\sum y)^2]}}$$

APPENDIX III

INTERCORRELATION MATRIX FOR THE FORCE EXERTIONS

The intercorrelation matrix shown on the following pages lists the correlation coefficients among the 44 force exertion measurements. The legend for the intercorrelation matrix lists the variable number and the variable name for each of the 44 force exertion measurements.

The intercorrelation matrix is read as follows: the correlation coefficient between variable 1 (Stick: Forward Force) and variable 2 (Stick: Backward Force) is 0.29; between variable 1 (Stick: Forward Force) and variable 3 (Stick: Backward Force, Inward Push) is 0.15 and so on.

A correlation coefficient of 0.28 is statistically greater than zero at the 0.05 level of confidence for $n = 51$.

APPENDIX III
INTERCORRELATION MATRIX FOR FORCE EXERTIONS

Variable No.	1	2	3	4	5	6	7	8	9	10
1	—	.29	.15	.49	.36	.43	.15	.39	.35	.48
2	.29	—	.24	.79	.59	.36	.53	.37	.34	.61
3	.15	.24	—	.28	.10	.14	.30	.38	.07	.19
4	.49	.79	.28	—	.59	.47	.54	.35	.49	.70
5	.36	.59	.10	.59	—	.59	.55	.52	.54	.55
6	.43	.36	.14	.47	.59	—	.35	.44	.48	.59
7	.15	.53	.30	.54	.55	.35	—	.44	.56	.55
8	.39	.37	.38	.35	.52	.44	.44	—	.50	.31
9	.35	.34	.07	.47	.54	.48	.56	.50	—	.73
10	.48	.61	.19	.70	.55	.59	.55	.31	.73	—
11	.41	.78	.14	.74	.70	.60	.61	.40	.57	.78
12	.34	.79	.22	.74	.60	.43	.68	.32	.54	.72
13	-.08	.33	.11	.24	.18	.14	.25	.07	.34	.23
14	.34	.65	.26	.73	.54	.68	.50	.26	.53	.66
15	.03	.49	.21	.42	.47	.40	.62	.32	.36	.39
16	.17	.46	.20	.40	.55	.55	.57	.53	.50	.43
17	.38	.51	.20	.51	.53	.54	.39	.29	.52	.60
18	.29	.54	.24	.67	.43	.41	.59	.22	.49	.51
19	.12	.25	.13	.20	.00	.04	.02	.16	.30	.20
20	.35	.37	.42	.41	.25	.29	.32	.29	.32	.45
21	.15	.52	.29	.44	.58	.49	.72	.52	.48	.47
22	.09	.03	.31	.02	.35	.35	.21	.32	.34	.32
23	.41	.44	.40	.42	.47	.40	.57	.47	.39	.39
24	.28	.63	.19	.53	.52	.43	.41	.12	.38	.54
25	.38	.48	.36	.49	.34	.40	.39	.27	.28	.46
26	.30	.43	.25	.50	.53	.43	.40	.30	.40	.44
27	.52	.34	.07	.40	.24	.40	.18	.18	.34	.51
28	.26	.51	.32	.54	.45	.44	.53	.37	.34	.48
29	.41	.44	.34	.48	.52	.57	.51	.25	.49	.63
30	.14	.43	.20	.42	.35	.24	.51	.09	.42	.53
31	.12	.43	.19	.40	.32	.27	.34	.24	.43	.33
32	.36	.52	.34	.51	.49	.72	.57	.38	.44	.57
33	.21	.68	.22	.45	.43	.31	.55	.35	.34	.42
34	.16	.49	.14	.31	.58	.55	.53	.45	.42	.51
35	.32	.36	.17	.34	.17	.02	.30	.21	.39	.36
36	.33	.60	.36	.53	.51	.29	.52	.23	.48	.54
37	.32	.48	.39	.50	.43	.45	.60	.45	.49	.54
38	.20	.21	.46	.39	.37	.49	.52	.32	.45	.46
39	.21	.46	.33	.30	.35	.12	.38	.18	.24	.23
40	.45	.58	.30	.47	.57	.48	.48	.47	.50	.53
41	.37	.29	.42	.37	.17	.24	.26	.33	.30	.43
42	.18	.42	.39	.39	.39	.31	.55	.19	.38	.46
43	.17	.35	.32	.39	.50	.46	.37	.24	.48	.49
44	.22	.45	.48	.44	.43	.39	.40	.27	.33	.37

INTERCORRELATION MATRIX FOR FORCE EXERTIONS

(Continued)

Variable No.	11	12	13	14	15	16	17	18	19	20
1	.41	.34	-.08	.34	.03	.17	.38	.29	.12	.35
2	.78	.79	.33	.65	.49	.46	.51	.54	.25	.37
3	.14	.22	.11	.26	.21	.20	.20	.24	.13	.42
4	.74	.74	.24	.73	.42	.40	.51	.67	.20	.41
5	.70	.60	.18	.54	.47	.55	.53	.49	.00	.25
6	.60	.43	.14	.68	.40	.65	.54	.41	.04	.29
7	.61	.68	.25	.50	.62	.57	.39	.59	.02	.32
8	.40	.32	.07	.26	.32	.53	.29	.22	.16	.29
9	.57	.54	.34	.53	.36	.50	.52	.49	.30	.32
10	.78	.72	.23	.66	.39	.43	.60	.51	.20	.45
11	—	.92	.18	.72	.51	.50	.60	.60	-.01	.40
12	.92	—	.25	.67	.53	.48	.51	.61	.03	.38
13	.18	.25	—	.43	.26	.29	.31	.24	.54	.32
14	.72	.67	.43	—	.50	.58	.66	.64	.15	.46
15	.51	.53	.26	.50	—	.61	.33	.67	.10	.36
16	.50	.48	.29	.58	.61	—	.39	.53	.21	.16
17	.60	.51	.31	.66	.33	.39	—	.49	.12	.35
18	.60	.61	.24	.64	.67	.53	.49	—	.05	.33
19	-.01	.03	.54	.15	.10	.21	.12	.05	—	.30
20	.40	.38	.32	.46	.36	.16	.35	.33	.30	—
21	.67	.61	.17	.57	.70	.59	.47	.59	.06	.40
22	.32	.28	.17	.24	.25	.37	.33	.17	.11	.32
23	.60	.65	.08	.44	.49	.50	.33	.51	-.02	.47
24	.64	.64	.23	.64	.46	.54	.45	.53	.19	.25
25	.55	.63	.09	.50	.29	.35	.43	.30	.05	.35
26	.49	.49	.15	.52	.56	.62	.32	.48	-.04	.47
27	.48	.39	-.16	.43	.19	.21	.49	.36	.02	.15
28	.69	.70	.00	.40	.42	.32	.37	.55	.18	.25
29	.68	.61	.17	.64	.41	.42	.54	.43	.16	.41
30	.53	.60	.35	.49	.22	.35	.48	.26	.15	.10
31	.41	.41	.57	.52	.31	.32	.49	.40	.39	.27
32	.67	.65	.22	.79	.54	.58	.54	.56	.08	.43
33	.66	.67	.36	.62	.51	.49	.62	.47	.12	.39
34	.64	.55	.16	.43	.44	.61	.54	.37	.06	.19
35	.29	.39	.56	.30	.11	.27	.27	.25	.53	.16
36	.55	.62	.26	.50	.31	.44	.50	.46	.31	.34
37	.55	.53	.15	.51	.46	.54	.37	.48	.24	.45
38	.37	.35	.31	.46	.31	.48	.40	.41	.11	.32
39	.40	.47	.26	.32	.48	.32	.39	.40	.28	.41
40	.60	.60	.33	.52	.36	.51	.45	.31	.30	.45
41	.33	.36	.06	.27	.13	.06	.18	.19	.33	.43
42	.52	.54	.09	.39	.46	.43	.31	.43	.17	.38
43	.46	.41	.27	.48	.40	.51	.55	.49	.27	.26
44	.42	.53	.39	.50	.29	.49	.31	.35	.30	.37

INTERCORRELATION MATRIX FOR FORCE EXERTIONS

(Continued)

Variable No.	21	22	23	24	25	26	27	28	29	30
1	.15	.09	.41	.28	.38	.30	.52	.26	.41	.14
2	.52	.03	.44	.63	.48	.43	.34	.51	.44	.43
3	.29	.31	.40	.19	.36	.25	.07	.37	.34	.20
4	.44	.02	.42	.53	.49	.50	.40	.54	.48	.42
5	.58	.35	.47	.52	.34	.53	.24	.45	.52	.35
6	.49	.35	.40	.43	.40	.43	.40	.44	.57	.24
7	.72	.31	.57	.41	.39	.40	.18	.53	.51	.51
8	.52	.32	.47	.12	.27	.30	.18	.32	.25	.09
9	.48	.34	.39	.38	.28	.40	.34	.34	.49	.42
10	.47	.32	.39	.54	.46	.44	.51	.48	.63	.53
11	.67	.32	.60	.64	.55	.49	.48	.69	.68	.53
12	.61	.28	.65	.64	.63	.49	.39	.70	.61	.60
13	.17	.17	.08	.23	.09	.15	.16	.00	.17	.35
14	.57	.24	.44	.64	.50	.52	.43	.40	.64	.49
15	.70	.25	.49	.46	.29	.56	.19	.42	.41	.22
16	.59	.37	.50	.54	.35	.62	.21	.32	.42	.35
17	.47	.33	.33	.45	.43	.32	.49	.37	.54	.48
18	.59	.17	.51	.53	.30	.48	.36	.55	.43	.26
19	.06	.11	-.02	.19	.05	-.04	.02	.18	.16	.15
20	.40	.32	.47	.25	.35	.47	.15	.25	.41	.10
21	—	.49	.63	.53	.44	.49	.36	.58	.56	.39
22	.49	—	.38	.25	.30	.32	.00	.26	.36	.32
23	.63	.38	—	.52	.64	.52	.24	.63	.45	.22
24	.53	.25	.52	—	.59	.61	.39	.39	.53	.44
25	.44	.30	.64	.59	—	.56	.30	.44	.43	.43
26	.49	.32	.52	.61	.56	—	.20	.32	.37	.23
27	.36	.00	.24	.39	.30	.20	—	.42	.54	.35
28	.58	.26	.63	.39	.44	.32	.42	—	.51	.31
29	.56	.36	.45	.53	.43	.37	.54	.51	—	.55
30	.39	.32	.22	.44	.43	.23	.35	.31	.55	—
31	.34	.37	.24	.44	.23	.30	.19	.33	.30	.39
32	.67	.41	.62	.57	.64	.45	.32	.48	.66	.39
33	.63	.28	.51	.60	.42	.36	.26	.37	.48	.46
34	.60	.45	.50	.54	.47	.33	.21	.41	.57	.36
35	.10	.21	.30	.23	.15	.08	.17	.17	.28	.45
36	.49	.30	.46	.62	.55	.55	.32	.35	.61	.53
37	.66	.42	.61	.52	.36	.36	.25	.47	.57	.36
38	.56	.47	.51	.35	.43	.37	.15	.45	.36	.44
39	.37	.18	.47	.42	.32	.46	.17	.33	.41	.26
40	.49	.42	.52	.59	.54	.57	.30	.42	.57	.49
41	.19	.26	.26	.17	.43	.22	.34	.35	.37	.37
42	.61	.50	.44	.59	.44	.50	.36	.41	.58	.48
43	.40	.43	.42	.58	.43	.49	.27	.38	.33	.33
44	.41	.41	.41	.53	.51	.49	.21	.31	.50	.59

INTERCORRELATION MATRIX FOR FORCE EXERTIONS

(Continued)

Variable No.	31	32	33	34	35	36	37	38	39	40
1	.12	.36	.21	.16	.32	.33	.32	.20	.21	.45
2	.43	.52	.68	.49	.36	.60	.48	.21	.46	.58
3	.19	.34	.22	.14	.17	.36	.39	.46	.33	.30
4	.40	.51	.45	.31	.34	.53	.50	.39	.30	.47
5	.32	.49	.43	.58	.17	.51	.43	.37	.35	.57
6	.27	.72	.31	.55	.02	.29	.45	.49	.12	.48
7	.34	.57	.55	.53	.30	.52	.60	.52	.38	.48
8	.24	.38	.35	.45	.21	.23	.45	.32	.18	.47
9	.43	.44	.34	.42	.39	.48	.49	.45	.24	.50
10	.33	.57	.42	.51	.36	.54	.54	.46	.23	.53
11	.41	.67	.66	.64	.29	.55	.55	.37	.40	.60
12	.41	.65	.67	.55	.39	.62	.53	.35	.47	.60
13	.57	.22	.36	.16	.56	.26	.15	.31	.26	.33
14	.52	.79	.62	.43	.30	.50	.51	.46	.32	.52
15	.31	.54	.51	.44	.11	.31	.46	.31	.48	.36
16	.32	.58	.49	.61	.27	.44	.54	.48	.32	.51
17	.49	.54	.62	.54	.27	.50	.37	.40	.39	.45
18	.40	.56	.47	.37	.25	.46	.48	.41	.40	.31
19	.39	.08	.12	.06	.43	.31	.24	.11	.28	.30
20	.27	.43	.39	.19	.16	.34	.45	.32	.41	.45
21	.34	.67	.63	.60	.10	.49	.66	.56	.37	.49
22	.37	.41	.28	.45	.21	.30	.42	.47	.18	.42
23	.24	.62	.51	.50	.30	.46	.61	.51	.47	.52
24	.44	.57	.60	.54	.23	.62	.52	.35	.42	.59
25	.23	.64	.42	.47	.15	.55	.36	.43	.32	.54
26	.30	.45	.36	.33	.08	.55	.36	.37	.46	.57
27	.19	.32	.26	.21	.17	.32	.25	.15	.17	.30
28	.33	.48	.37	.41	.17	.35	.47	.45	.33	.42
29	.30	.66	.48	.57	.28	.61	.57	.36	.41	.57
30	.39	.39	.46	.36	.45	.53	.36	.44	.26	.49
31	—	.33	.47	.33	.44	.40	.26	.34	.48	.41
32	.33	—	.59	.63	.22	.53	.61	.52	.32	.54
33	.47	.59	—	.52	.29	.49	.40	.26	.58	.50
34	.33	.63	.52	—	.15	.56	.56	.37	.41	.60
35	.44	.22	.29	.15	—	.40	.33	.26	.17	.39
36	.40	.53	.49	.56	.40	—	.51	.38	.53	.68
37	.26	.61	.40	.56	.33	.51	—	.58	.27	.51
38	.34	.52	.26	.37	.26	.38	.58	—	.16	.42
39	.48	.32	.58	.41	.17	.53	.27	.16	—	.48
40	.41	.54	.50	.60	.39	.68	.51	.42	.48	—
41	.29	.29	.15	.14	.19	.38	.29	.33	.32	.36
42	.32	.47	.45	.46	.15	.59	.57	.46	.48	.46
43	.47	.42	.28	.61	.23	.61	.52	.43	.40	.43
44	.42	.51	.44	.40	.32	.57	.46	.51	.48	.67

INTERCORRELATION MATRIX FOR FORCE EXERTIONS

(Continued)

Variable No.	41	42	43	44
1	.37	.18	.17	.22
2	.29	.42	.35	.45
3	.42	.39	.32	.48
4	.37	.39	.39	.44
5	.17	.39	.50	.43
6	.24	.31	.46	.39
7	.26	.55	.37	.40
8	.33	.19	.24	.27
9	.30	.38	.38	.33
10	.43	.46	.49	.37
11	.33	.52	.46	.42
12	.36	.54	.41	.53
13	.06	.09	.27	.39
14	.27	.39	.48	.50
15	.13	.46	.40	.29
16	.06	.43	.51	.49
17	.18	.31	.55	.31
18	.19	.43	.49	.35
19	.33	.17	.27	.30
20	.43	.38	.26	.37
21	.19	.61	.40	.41
22	.26	.50	.43	.41
23	.26	.44	.42	.44
24	.17	.59	.58	.53
25	.43	.44	.43	.51
26	.22	.50	.49	.49
27	.34	.36	.27	.21
28	.35	.41	.38	.31
29	.37	.58	.33	.50
30	.37	.48	.33	.59
31	.29	.32	.47	.42
32	.29	.47	.42	.51
33	.15	.45	.28	.44
34	.14	.46	.61	.40
35	.19	.15	.23	.32
36	.38	.59	.61	.57
37	.28	.57	.52	.46
38	.33	.46	.43	.51
39	.32	.48	.40	.48
40	.36	.46	.43	.67
41	—	.48	.35	.46
42	.48	—	.48	.58
43	.35	.48	—	.44
44	.46	.58	.44	—

APPENDIX IV

CORRELATIONS COEFFICIENTS BETWEEN MEASURES OF FORCE EXERTIONS AND BODY SIZE, GRIP STRENGTH, AND AGE

Variable Name	Weight	Stature	Sitting Height	Thumb-Tip Reach	Lateral Thumb-Tip Reach	Grip Strength I	Grip Strength II	Grip Strength III	Grip Strength Average	Age
STICK										
Forward Force	.06	.02	.11	.30	.10	.30	.46	.40	.41	-.17
Backward Force,	.34	.10	.14	.12	.29	.32	.36	.40	.38	-.12
Backward Force Inward Push	.26	.33	.26	.46	.40	.08	.02	.14	.03	-.05
Backward Force, Two Hands	.37	.09	.07	.22	.30	.37	.44	.49	.46	-.05
Left Force	.55	.23	.32	.18	.27	.32	.41	.37	.39	-.12
Right Force	.56	.47	.39	.44	.45	.36	.41	.42	.42	-.14
Up Force	.66	.29	.35	.33	.46	.37	.35	.43	.41	-.09
Down Force	.26	.03	.09	.08	.03	.23	.34	.33	.32	-.20
THROTTLE										
Forward Force, Handle Vertical	.34	.06	.11	.15	.01	.14	.27	.25	.23	-.12
Forward Force, Handle Horizontal	.43	.16	.14	.41	.31	.31	.43	.51	.44	-.18
Backward Force, Handle Vertical	.58	.32	.33	.39	.44	.56	.62	.63	.64	-.17
Backward Force, Handle Horizontal	.55	.29	.32	.40	.42	.45	.48	.53	.51	-.25
Left Force	.11	.09	.27	-.05	-.01	-.15	-.13	-.09	-.13	-.05
Right Force	.52	.37	.29	.40	.46	.33	.38	.45	.41	-.09
Up Force	.64	.43	.38	.33	.51	.20	.18	.19	.20	-.03
Down Force	.65	.45	.42	.24	.43	.16	.23	.27	.23	-.19
COLLECTIVE										
Forward Force	.27	.13	.16	.27	.21	.29	.43	.38	.39	.03
Backward Force	.54	.21	.19	.24	.36	.43	.37	.40	.42	.01
Left Force	-.13	-.04	.01	-.11	-.16	-.34	-.17	-.13	-.23	-.09
Right Force	.17	.24	.25	.45	.28	.10	.22	.32	.22	-.09
Up Force	.73	.35	.40	.33	.47	.33	.36	.39	.38	.01
Down Force	.47	.43	.47	.45	.39	.14	.20	.25	.21	-.18
OVERHEAD CONTROL										
Forward Force	.57	.51	.58	.53	.51	.35	.36	.40	.39	-.26
Backward Force	.58	.38	.42	.31	.45	.18	.19	.25	.22	-.17
Left Force	.43	.41	.47	.44	.48	.14	.17	.25	.20	-.13
Right Force	.45	.40	.45	.36	.38	.05	.13	.25	.15	-.08
Up Force	.16	-.08	-.08	.21	.17	.22	.39	.33	.33	-.18
Down Force	.49	.24	.26	.42	.37	.44	.51	.52	.52	-.18

**CORRELATIONS COEFFICIENTS BETWEEN MEASURES
OF FORCE EXERTIONS AND BODY SIZE,
GRIP STRENGTH, AND AGE**

(Continued)

Variable Name	Weight	Stature	Sitting Height	Thumb-Tip Reach	Lateral Thumb-Tip Reach	Grip Strength I	Grip Strength II	Grip Strength III	Grip Strength Average	Age
PANEL CONTROL										
Forward Force	.51	.44	.36	.51	.53	.40	.58	.55	.54	-.12
Backward Force	.38	.22	.28	.24	.36	.13	.24	.31	.24	-.02
Left Force	.22	.13	.23	.12	.12	.06	.09	.15	.11	-.22
Right Force	.71	.55	.49	.54	.56	.36	.38	.40	.40	-.13
Up Force	.47	.33	.34	.19	.38	.32	.33	.36	.36	-.11
Down Force	.57	.42	.41	.28	.41	.40	.45	.34	.41	-.11
HATCH CONTROL										
Forward Force	.10	-.07	.16	.09	.00	.04	.13	.10	.09	-.35
Backward Force	.34	.19	.25	.28	.27	.21	.29	.34	.30	-.06
Left Force	.55	.35	.28	.45	.38	.25	.38	.39	.36	-.12
Right Force	.49	.38	.40	.41	.44	.07	.11	.30	.17	-.03
Up Force	.21	.34	.31	.21	.35	.12	.17	.20	.17	-.09
Down Force	.34	.24	.39	.28	.23	.18	.35	.34	.31	-.05
Forward Force—45°	.01	.09	.05	.27	.22	.00	.05	.25	.11	-.24
Backward Force—45°	.50	.42	.42	.42	.53	.15	.20	.29	.23	-.15
Left Force—45°	.38	.36	.27	.29	.40	.13	.20	.23	.19	-.12
Right Force—45°	.39	.38	.42	.24	.37	.08	.01	.17	.04	-.13

A correlation coefficient of 0.28 is statistically greater than zero at the 0.05 level of confidence for $n = 51$.

APPENDIX V

Eleven of the experimental subjects completed test-retest sessions on two separate occasions. Within a one-week period, the subjects repeated the entire set of 44 force exertions.

The actual differences between the mean values for the force exertion measurements were found to be less than or equal to 1% for 13 of the 44 measurements; less than or equal to 5% for 17 of the 44 measurements; less than or equal to 10% for 9 of the 44 measurements; and greater than 10% for 5 of the 44 measurements.

The test and retest means and standard deviations are shown in the following table.

TEST-RETEST RESULTS OF FORCE EXERTIONS*
(n=11)

<i>Variable Name</i>	<i>Test</i>		<i>Retest</i>	
	<i>Mean</i>	<i>SD</i>	<i>Mean</i>	<i>SD</i>
STICK				
Forward Force	60.2	12.0	60.2	14.4
Backward Force	79.2	14.0	74.5	7.3
Backward Force, Inward Push	68.4	10.4	68.1	19.4
Backward Force, Two Hands	156.6	20.2	155.6	18.0
Left Force	54.2	7.0	58.7	10.9
Right Force	58.3	13.6	57.5	9.3
Up Force	59.4	15.5	65.0	11.8
Down Force	89.5	26.5	89.9	22.1
THROTTLE				
Forward Force, Handle Vertical	142.9	41.2	123.6	28.9
Forward Force, Handle Horizontal	136.1	35.9	135.5	19.2
Backward Force, Handle Vertical	99.0	13.0	95.6	15.3
Backward Force, Handle Horizontal	97.5	14.2	96.0	13.9
Left Force	28.1	10.7	22.4	6.4
Right Force	40.1	9.5	39.2	8.9
Up Force	39.8	11.4	39.6	10.4
Down Force	53.8	13.6	53.3	9.7
COLLECTIVE				
Forward Force	62.6	12.0	56.0	13.7
Backward Force	55.0	8.1	55.5	10.6
Left Force	36.1	14.6	34.1	13.7
Right Force	45.0	10.1	45.5	8.9
Up Force	79.7	19.7	87.3	11.7
Down Force	72.5	15.2	77.9	11.5
OVERHEAD CONTROL				
Forward Force	25.5	7.4	25.8	8.3
Backward Force	17.4	4.3	17.4	2.4
Left Force	24.0	7.6	22.9	5.1
Right Force	24.3	7.5	22.2	3.9
Up Force	160.3	39.5	155.1	44.0
Down Force	95.5	9.7	92.7	8.2
PANEL CONTROL				
Forward Force	154.1	36.4	154.5	34.3
Backward Force	108.7	12.1	108.3	17.8
Left Force	24.1	9.4	22.2	3.6
Right Force	29.9	6.4	32.0	6.2
Up Force	24.0	4.9	23.3	5.1
Down Force	35.5	7.2	37.0	7.5

TEST-RETEST RESULTS OF FORCE EXERTIONS*

(n=11)

(Continued)

<i>Variable Name</i>	<i>Test</i>		<i>Retest</i>	
	<i>Mean</i>	<i>SD</i>	<i>Mean</i>	<i>SD</i>
HATCH CONTROL				
Forward Force	29.8	14.0	37.6	16.3
Backward Force	44.5	7.8	42.9	7.5
Left Force	62.5	16.2	71.3	13.7
Right Force	49.7	12.6	51.7	16.0
Up Force	29.8	8.5	31.3	9.0
Down Force	40.2	7.5	42.0	9.5
Forward Force—45°	93.5	12.9	90.7	9.6
Backward Force—45°	84.8	13.5	81.3	10.4
Left Force—45°	35.7	6.7	35.9	6.1
Right Force—45°	36.5	7.1	36.8	8.4

*All force exertions are reported in pounds.

REFERENCES

- Churchill, Edmund, "The Computational Procedures," Section V in *Anthropometric Survey of Air Force Women—1968* by C. E. Clauser, P. Tucker, J. T. McConville, E. Churchill, L. L. Laubach, and J. Reardon, AMRL-TR-70-5, Wright-Patterson Air Force Base, Ohio: Aerospace Medical Research Laboratory, (in press).
- Churchill, Edmund, "Statistical Considerations," Chapter 3 in *Human Development*, Frank Faulkner (editor), Philadelphia: W. B. Saunders Company, 1966.
- Damon, Albert, Howard W. Stoudt, and Ross A. McFarland, *The Human Body in Equipment Design*, Cambridge, Massachusetts: Harvard University Press, 1966.
- Department of the Air Force, *Dimensions, Basic, Cockpit, Helicopter*, Military Standard MS-33575, U.S. Government Printing Office, Washington, D.C., June 1969.
- Department of the Air Force, *Dimensions, Basic, Cockpit, Stick Controlled Fixed-Wing Aircraft*, Military Standard MS-33574, U.S. Government Printing Office, Washington, D.C., June 1969.
- Heebøll-Nielsen, Kr., "Muscular Assymetry in Normal Young Men," *Communications from The Danish National Association for Infantile Paralysis*, Nr. 18, 1964.
- Hunsicker, Paul A., *Arm Strength at Selected Degrees of Elbow Flexion*, WADC Technical Report 54-548, Wright-Patterson Air Force Base, Ohio: Wright Air Development Center, August 1955. (AD 81 792)
- Hunsicker, Paul A., *A Study of Muscle Forces and Fatigue*, WADC Technical Report 57-586, Wright-Patterson Air Force Base, Ohio: Wright Air Development Center, December 1957. (AD 131087)
- Kennedy, Kenneth W., *Reach Capabilities of the USAF Population Phase 1 The Outer Boundaries of Grasping-Reach Envelopes for the Shirt-Sleeved, Seated Operator*, AMRL-TDR-64-59, Wright-Patterson Air Force Base, Ohio: Aerospace Medical Research Laboratories, September 1964. (AD 608269)
- Kroemer, K. H. E., *Human Strength: Terminology, Measurement and Interpretation of Data*, AMRL-TR-69-9, Wright-Patterson Air Force Base, Ohio: Aerospace Medical Research Laboratory, May 1970. Also published in *Human Factors*, 12(3), 297-313, June 1970.
- Kroemer, K. H. E., and J. M. Howard, *Problems in Assessing Muscle Strength*, AMRL-TR-68-144, Wright-Patterson Air Force Base, Ohio: Aerospace Medical Research Laboratory, May 1970. (AD 708 741)
- Kroemer, K. H. E., and J. M. Howard, "Towards Standardization of Muscle Strength Testing," *Medicine and Science in Sports*, 2(4), 224-230, Winter 1970.
- Kroemer, K. H. E., and D. E. Robinson, *Horizontal Static Forces Exerted by Men Standing in Common Working Positions on Surfaces of Various Traction*, AMRL-TR-70-114, Wright-Patterson Air Force Base, Ohio: Aerospace Medical Research Laboratory, January 1971.
- Laubach, Lloyd L., and John T. McConville, "Muscle Strength, Flexibility, and Body Size of Adult Males," *Research Quarterly*, 37(3), 384-392, October 1966.
- Laubach, Lloyd L., and John T. McConville, "The Relationship of Strength to Body Size and Typology," *Medicine and Science in Sports*, 1(4), 189-194, December 1969.
- Watt, D. N., *Maximum Forces Exerted on a Stick Type Control Column*, Report 63-RD-1, Royal Canadian Air Force, Toronto 12, Ontario, Canada: Institute of Aviation Medicine, January 1963.