

File Copy

BRL MR 2177

BRL

AD

MEMORANDUM REPORT NO. 2177

THE DYNAMICS OF CAM SYSTEMS FOR GUN MECHANISMS

by

Herman P. Gay

April 1972

Approved for public release; distribution unlimited.

U.S. ARMY ABERDEEN RESEARCH AND DEVELOPMENT CENTER
BALLISTIC RESEARCH LABORATORIES
ABERDEEN PROVING GROUND, MARYLAND

Destroy this report when it is no longer needed.
Do not return it to the originator.

Secondary distribution of this report by originating or
sponsoring activity is prohibited.

Additional copies of this report may be purchased from
the U.S. Department of Commerce, National Technical
Information Service, Springfield, Virginia 22151

The findings in this report are not to be construed as
an official Department of the Army position, unless
so designated by other authorized documents.

B A L L I S T I C R E S E A R C H L A B O R A T O R I E S

MEMORANDUM REPORT NO. 2177

APRIL 1972

THE DYNAMICS OF CAM SYSTEMS FOR GUN MECHANISMS

Herman P. Gay

Interior Ballistics Laboratory

Approved for public release; distribution unlimited.

RDT&E Project No. IT061102A33C

A B E R D E E N P R O V I N G G R O U N D , M A R Y L A N D

B A L L I S T I C R E S E A R C H L A B O R A T O R I E S

MEMORANDUM REPORT NO. 2177

HPGay/mfp
Aberdeen Proving Ground, Md.
April 1972

THE DYNAMICS OF CAM SYSTEMS FOR GUN MECHANISMS

ABSTRACT

A general method is described for calculating the dynamics of systems that include cams and followers. The method is especially suited to the analog computer. Since the analog computer has proven to be an effective tool for simulating automatic gun mechanisms and, since cams and followers generally are a part of those mechanisms, this method can be used to establish a more detailed and complete simulation.

Two spring-mass systems coupled through a cam are simulated to illustrate the method. Clearance between the follower and the cam track can be included without complexity.

TABLE OF CONTENTS

	Page
ABSTRACT	3
LIST OF ILLUSTRATIONS.	7
INTRODUCTION	9
ANALYSIS	9
DISCUSSION	19
ACKNOWLEDGMENT	20
DISTRIBUTION LIST.	21

LIST OF ILLUSTRATIONS

Figure		Page
1.	Coupled System	10
2.	Circuit Diagrams	12
3.	Motion Within 45° Slope.	13
4.	Cam Path	14
5.	Diagram for Generating $\psi'(x)$	15
6.	Diagram for Generating $\psi(x)$ and F_y	16
7.	Diagram for Generating F_x	16
8.	Damped Motion with Dwell-Rise-Dwell.	17
9.	Diagram of Dead-Space Circuit.	18
10.	The Effect of Clearance.	18

INTRODUCTION

Cams are used in many automatic gun mechanisms to lock and to unlock the bolt and to operate the ammunition feed system. In the Gatling-type guns the entire gun mechanism is driven and controlled by a rotating cylindrical cam. Thus, the kinematics and dynamics of cams are essential parts of the calculations of the motion of automatic gun mechanisms.

The analog computer has proven to be an effective tool for simulating automatic gun mechanisms*. However, the usual mathematical methods used in cam dynamics are not well suited to the analog computer and other methods were studied to solve the problem.

ANALYSIS

A cam may be defined as a mechanical element of a machine which is used to drive another element, called the follower, through a specified movement by direct contact. In most gun mechanisms the forces transmitted by the cam are significant as compared to the driving forces, so that the problem is to determine the effect of those forces on the motion.

The cam path (specified movement) may consist of segments of straight lines, circles, sinusoids, etc., so that the path in the XY plane may be represented by:

$$y = f(x)$$

After the equations of motion along X and Y are written, the y-coordinate can be transformed to x by the standard procedure that uses the chain rule and the product rule for differentiation:

*"Analog Simulation of the 20mm Gun, M139," H. P. Gay and E. M. Wineholt, Ballistic Research Laboratories Report No. 1436, June 1969. (AD 855145)

$$\frac{dy}{dt} = \frac{dy}{dx} \frac{dx}{dt}$$

$$\begin{aligned} \frac{d^2y}{dt^2} &= \frac{dy}{dx} \frac{d^2x}{dt^2} + \frac{dx}{dt} \frac{d}{dt} \left(\frac{dy}{dx} \right) \\ &= \frac{dy}{dx} \frac{d^2x}{dt^2} + \frac{dx}{dt} \left[\frac{d}{dx} \left(\frac{dy}{dx} \frac{dx}{dt} \right) \right] \end{aligned}$$

$$\frac{d^2y}{dt^2} = \frac{dy}{dx} \frac{d^2x}{dt^2} + \left(\frac{dx}{dt} \right)^2 \frac{d^2y}{dx^2}$$

Thus, given $y = f(x)$, (and the first two derivatives with respect to x) one can calculate the motion. As indicated previously, a solution by the analog computer would require three multipliers and three diode function generators.

A technique developed by J. P. Laird* has been adapted to this cam problem. In his method the elastic force developed by an impact is given by:

$$F = -k\varepsilon, \text{ where} \quad (1)$$

k = a very large spring rate, and

ε = the deformation.

Consider the simple spring-mass systems linked by a cam as shown in Figure 1.

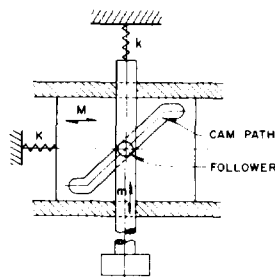

Figure 1. Coupled System

*"Analog Simulation of Mechanical Impact," J. P. Laird, Simulation, Vol. 4, No. 5, 1965, pp. 295-300.

The mass M (cam) moves horizontally; the mass m (follower) moves vertically. The equations of motion are:

$$M\ddot{x} = -Kx + F_x \quad (2)$$

$$m\ddot{y} = -ky + F_y, \text{ where} \quad (3)$$

F_x and F_y = components of the contact force between the cam and the follower.

The deformation ϵ (or the interference between the cam and the follower) is given by:

$$\epsilon_x = x - \phi(y) \quad (4)$$

$$\epsilon_y = y - \psi(x), \quad (5)$$

where $\phi(y)$ and $\psi(x)$ are the prescribed cam path.

As a first example, consider the motion when it is restricted to the 45° slope of the cam.

Then $y = x$.

When a follower roller is used the contact force is normal to the cam surface, so that:

$$F_y = -F_x$$

Equations (2) and (3) then become:

$$(M + m)\ddot{x} = -(K + k)x \quad (6)$$

To illustrate this motion, a hypothetical problem with the following parameters will be used:

$$M = 0.026 \text{ lb sec}^2/\text{in} \text{ (10 lb)}$$

$$K = 15 \text{ lb/in}$$

$$m = 0.013 \text{ lb sec}^2/\text{in} \text{ (5 lb)}$$

$$k = 45 \text{ lb/in}$$

The system is initially at rest. An initial velocity $\dot{x}(0) = 29.5$ ips is imparted to M, so that the initial velocity of the system is:

$$v(0) = \frac{M\dot{x}(0)}{(M+m)} = 19.7 \text{ ips}$$

The time per cycle T is:

$$T = \frac{2\pi}{\omega}$$

$$= 2\pi \left(\frac{M+m}{K+k} \right)^{1/2} = 0.160 \text{ sec.}$$

and the maximum amplitude is:

$$x_m = \frac{v(0)}{\omega} = 0.50 \text{ in.}$$

Circuit diagrams for the analog computer solution are shown in Figure 2. A function generator to produce $\psi(x)$ is shown for generality. In this particular problem,

$$\psi(x) = x, \text{ and}$$

$$\phi(y) = y.$$

Note that k was taken to be 10^4 lb/in, about 200 times greater than K .

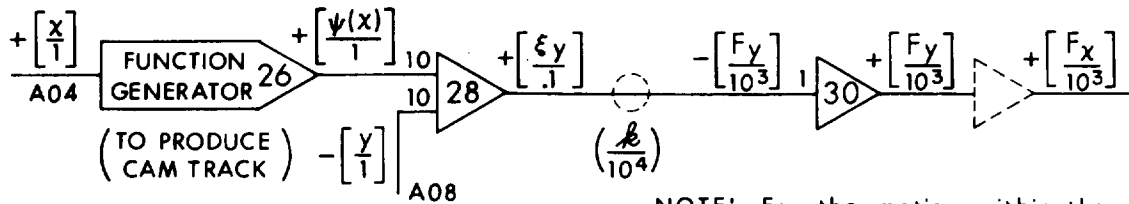

NOTE: For the motion within the 45° slope, $F_x = -F_y$.

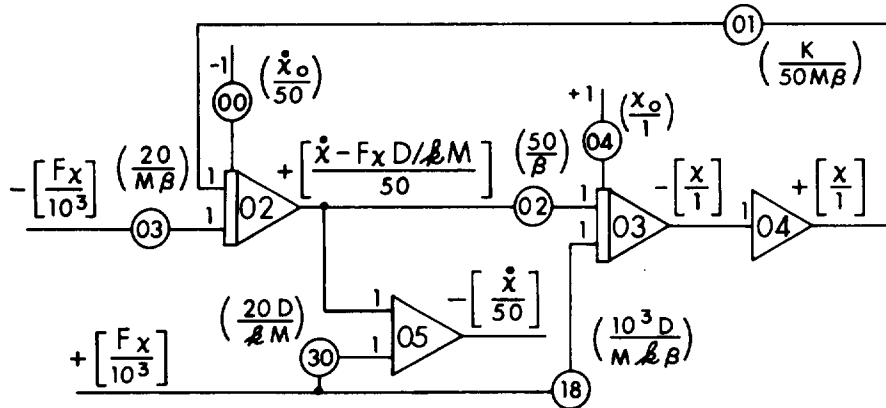

Figure 2. Circuit Diagrams

Only the diagram for x is shown in Figure 2. The diagram for y is essentially the same.

Figure 3 shows the calculated displacement and velocity.

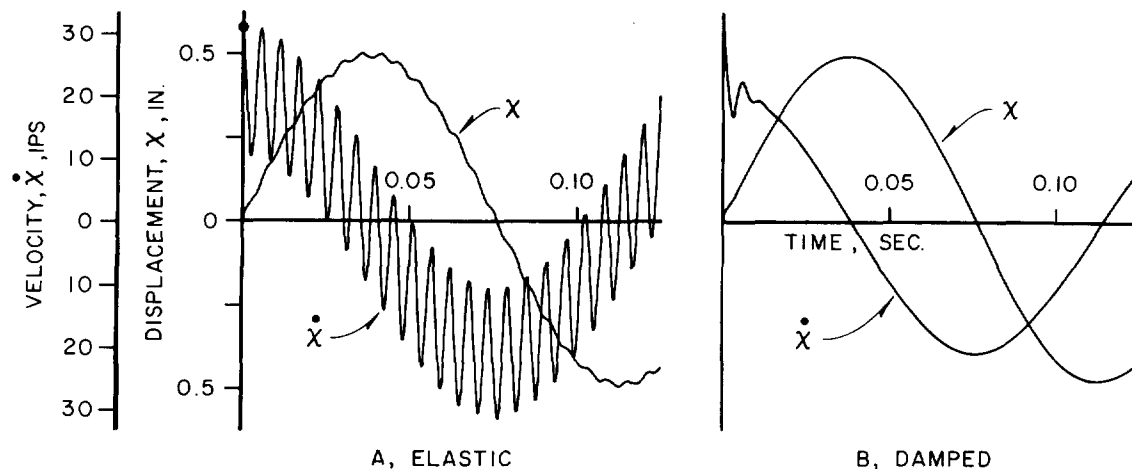

Figure 3. Motion Within 45° Slope

Figure 3A shows the results when the contact, or coupling, force is elastic. Note that the initial velocity is suddenly changed by the impact of M on m. Successive impacts cause the velocity to oscillate about a mean value that may be obtained from the solution of equation (6). The displacement-time curve is naturally more smooth than the velocity curve.

To obtain a smoother solution the impact was assumed to be inelastic, with a coefficient of restitution of one-half. The viscous damping coefficient D that produces the equivalent loss of energy can be shown (from the previous reference and a little analysis) to be:

$$D = 0.4\sqrt{k \left(\frac{Mm}{M+m} \right)} \quad (7)$$

The resultant solution is shown in Figure 3B.

A more practical cam path is shown in Figure 4, consisting of a dwell-rise-dwell.

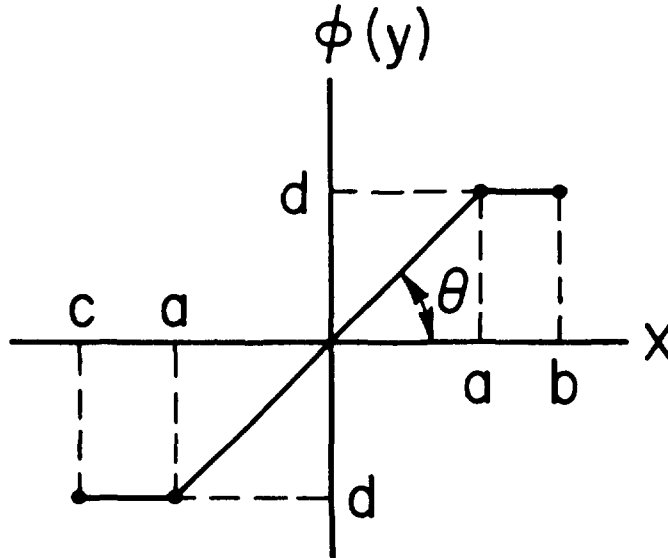

Figure 4. Cam Path

For the cam path of Figure 4, $y - \psi(x)$ is well-behaved because $\psi(x)$ is single-valued. However, $x - \phi(y)$ is not well-behaved because $\phi(y)$ is multivalued where the cam path is horizontal. Furthermore, the use of separate function generators to produce $\psi(x)$ and $\phi(y)$ is not good practice because $\psi(x)$ and $\phi(y)$ are not independent. Other means of producing the two components of the contact force will therefore be developed.

For F_y the previous technique will be used:

$$F_y = -k\epsilon_y, \text{ and} \quad (8)$$

$$\epsilon_y = y - \psi(x) \quad (9)$$

When there is no sliding friction the contact force is normal to the cam surface, and its two components will be in the ratio:

$$-\frac{F_x}{F_y} = \tan \theta = \psi'(x), \text{ or} \quad (10)$$

$$F_x = -F_y \psi'(x)$$

Also:

$$\begin{aligned}\psi(x) &= \int \psi'(x) dx \\ &= \psi(x_0) + \int_0^t \psi'(x) \dot{x} dt, \text{ for } x = x_0 \text{ when } t = 0 \quad (11)\end{aligned}$$

Equations (8) to (11) are sufficient for calculating the cam forces. Note that only one function generator and two multipliers are used. In addition the use of $\psi'(x)$ rather than $\psi(x)$ makes it easier to simulate complex cam tracks on a function generator because discontinuities (or roughness) in $\psi'(x)$ are smoothed by integration. (Conversely, roughness in $\psi(x)$ is accentuated in $\psi'(x)$.)

To illustrate this technique the springs and masses of the previous problem were linked with a dwell-rise-dwell cam (Figure 4), with the following data:

$a = 0.6$ in	$x(0) = -1.0$ in
$b = 0.75$ in	$y(0) = -0.6$ in
$c = 1.0$ in	$\dot{x}(0) = 0 = \dot{y}(0)$
$d = 0.6$ in	coeff. at restitution = 0.5

Instead of using a function generator to produce $\psi'(x)$, the circuits shown in Figure 5 were used because $\psi'(x)$ has a square shape, as shown.

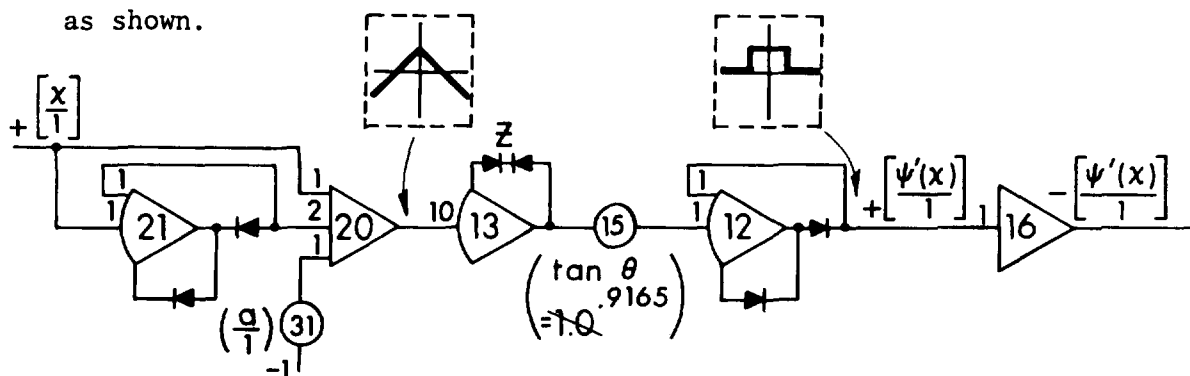

Figure 5. Diagram for Generating $\psi'(x)$

Equation (11) was used to calculate $\psi(x)$, as illustrated in the circuits of Figure 6. The circuits for generating F_y are also shown in Figure 6.

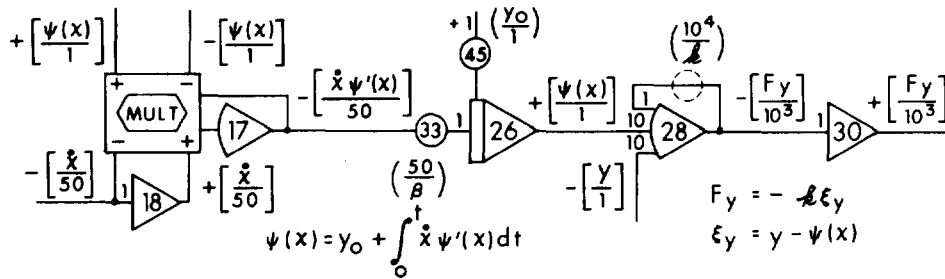

Figure 6. Diagram for Generating $\psi(x)$ and F_y

The horizontal component F_x of the contact force is obtained from F_y as illustrated in Figure 7.

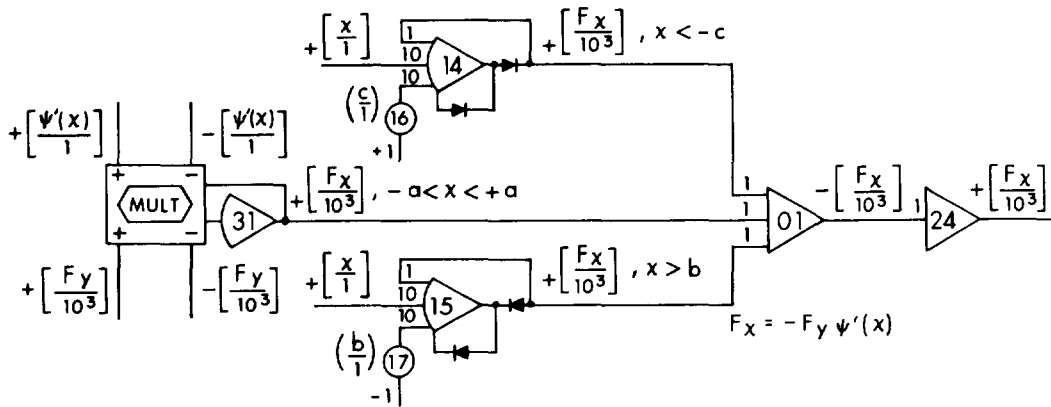

Figure 7. Diagram for Generating F_x

Note that limit stops (or very large forces) at the end of the cam track are generated by amplifiers 14 and 15.

The circuits of Figures 5, 6, and 7 provided the forcing functions for the basic three-element loops such as shown in Figure 2. The resultant displacements and velocities of the two masses are shown in Figure 8.

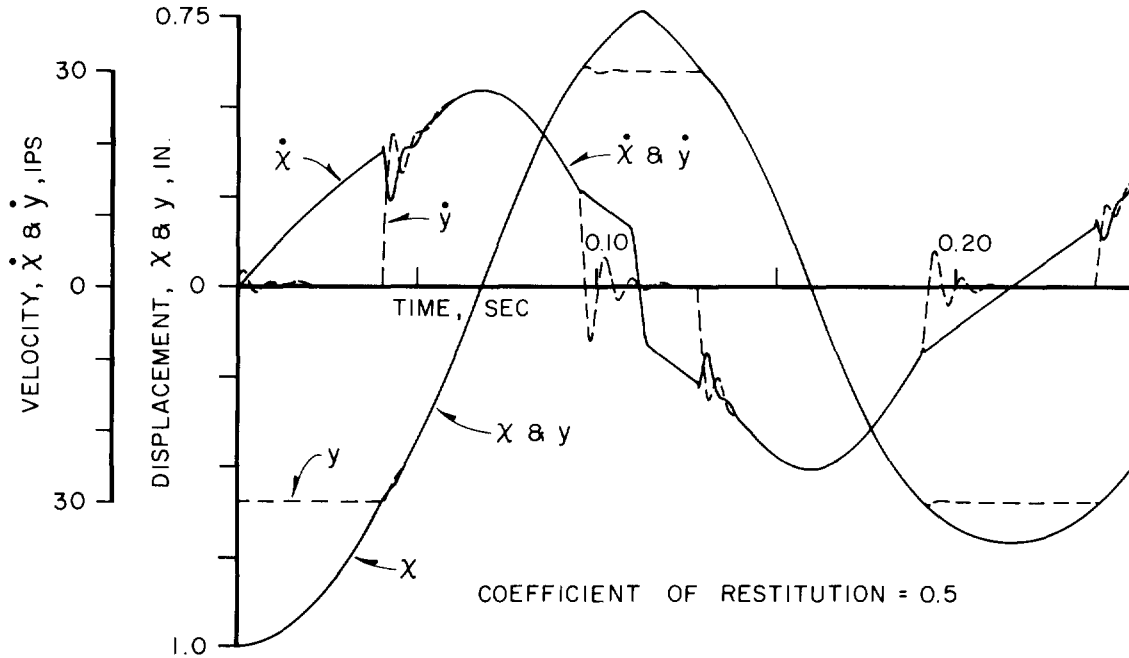

Figure 8. Damped Motion with Dwell-Rise-Dwell

There is some overshoot of the velocity at the instant of impact, but it is damped out in a few cycles.

In actual practice there is some clearance between the follower roller and the cam track. In this case the elastic part of the contact force is redefined as:

$$F = \begin{cases} -k(\epsilon + \Delta), & \epsilon < -\Delta \\ 0 & -\Delta < \epsilon < +\Delta \\ -k(\epsilon - \Delta), & \epsilon > +\Delta \end{cases}$$

where Δ is the clearance. A constant clearance ($\Delta = 0.05$ in.) can be simulated on the analog computer by use of the dead space circuit illustrated in Figure 9.

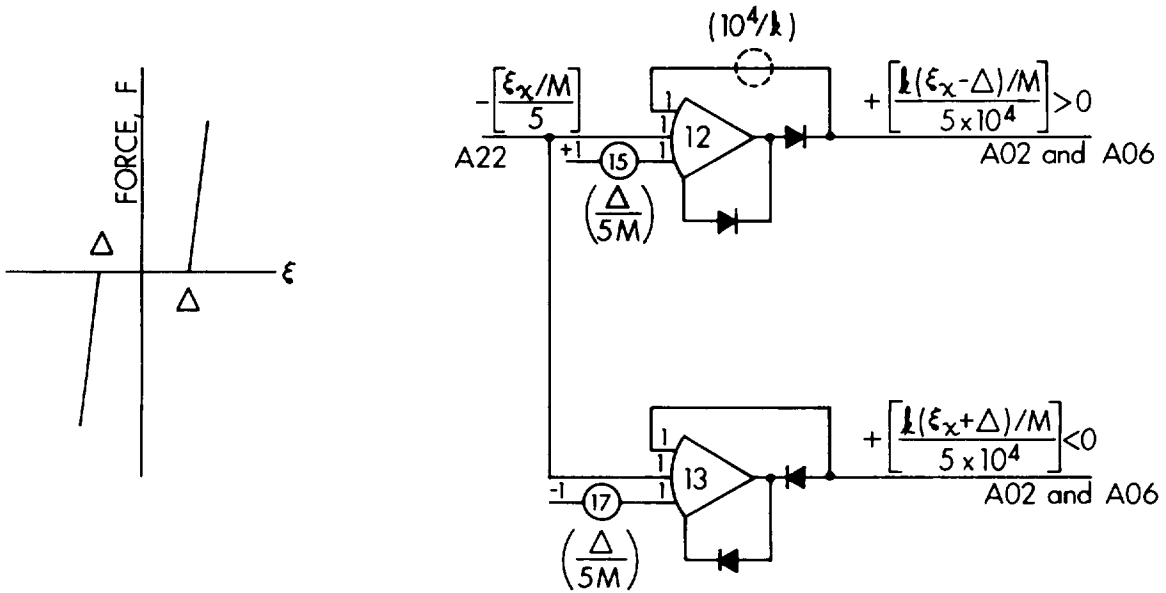

Figure 9. Diagram of Dead-Space Circuit

The XY plot of the motion with clearance added to that of Figure 8 is shown in Figure 10A.

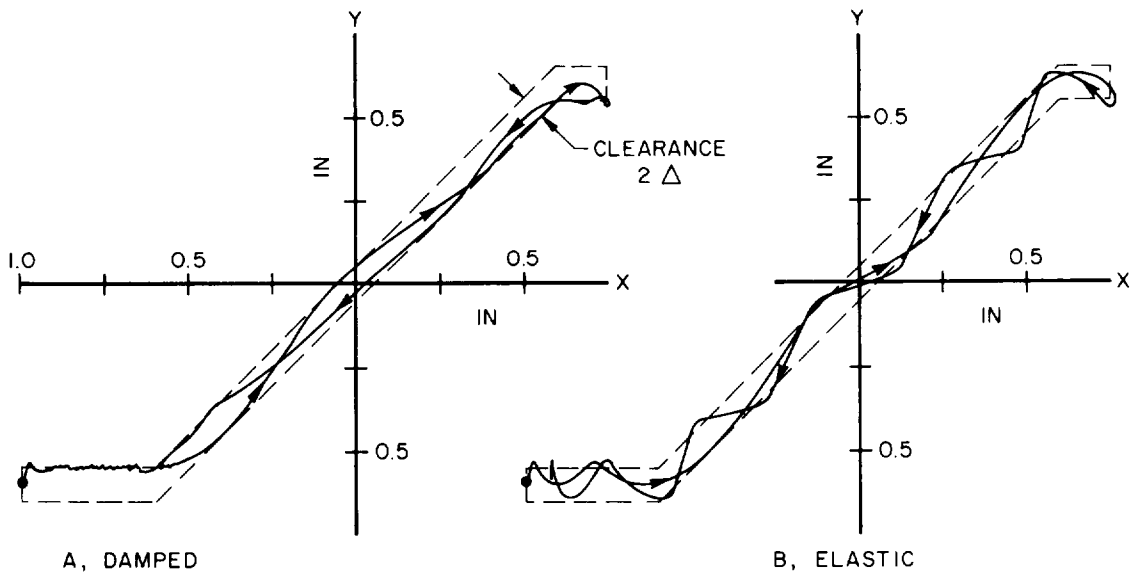

Figure 10. The Effect of Clearance

Figure 10B shows the same problem with the damping removed, thus producing more impacts.

DISCUSSION

In setting up the problem on the analog computer the problem time must be sufficiently long, so that the amplifiers can generate and respond to the short duration contact force. If a servo-plotter is used to plot the output, its response generally will dictate the time scale. Another troublesome detail is to select an appropriate value for the contact force. The literature indicates that 20 to 500 times larger than the other forces is reasonable. Our experience confirms this fact. If the amplifier which generates the contact force (A28 of Figure 2) tends to overload, the high gain can be attained by using a gain of ten or more into the integrator.

It should be remembered that this physical (or mathematical) model is not sophisticated enough to yield the forces or stresses associated with the contact force. The displacements, and to a lesser extent, the velocities of the masses are adequate for most practical purposes, but this rigid body model will not yield the local forces and deformations during impact. Furthermore, it should be noted that when damping is used, the contact force (consisting of an elastic and a viscous component) is not formed explicitly in the main loop. Neither is the velocity, as indicated in Figure 2.

In simulating an existing system the damping can be adjusted so that the simulation agrees with observation. For a system that does not exist, one must rely on experience. Some damping should be used so that the analog circuits are stable--and so that the model is realistic. The choice of a value is not critical; for example in Figure 3, the coefficient of restitution was 0.5 and the oscillation in the velocity was damped out in about three cycles. When the coefficient of restitution was changed to 0.8, the oscillation was damped out in seven cycles.

This technique generally is useful for calculating the dynamic response of high speed mechanical components driven by cams. It has been used successfully at the Ballistic Research Laboratories to simulate the locking and unlocking of the bolt and cocking the hammer of the M16 Rifle. It is not limited to small caliber automatic weapons. It could be used, for example, to calculate the breech block motion and the cartridge case ejection produced by the breech block cam of a tank gun.

ACKNOWLEDGMENT

The author is grateful to Emma M. Wineholt for carrying out the simulation and preparing the illustrations.

DISTRIBUTION LIST

<u>No. of Copies</u>	<u>Organization</u>	<u>No. of Copies</u>	<u>Organization</u>
12	Commander Defense Documentation Center ATTN: TIPCR Cameron Station Alexandria, VA 22314	2	Commanding General U.S. Army Tank-Automotive Command ATTN: AMSTA-RHFL AMSTA-CL, Dr. Petrick Warren, Michigan 38090
1	Commanding General U.S. Army Materiel Command ATTN: AMCDL Washington, DC 20315	2	Commanding Officer U.S. Army Mobility Equipment Research & Development Center ATTN: Tech Docu Cen, Bldg. 315 AMSME-RZT Fort Belvoir, VA 22060
1	Commanding General U.S. Army Materiel Command ATTN: AMCRD, Dr. J.V.R. Kaufman Washington, DC 20315	1	Commanding General U.S. Army Munitions Command ATTN: AMSMU-RE Dover, New Jersey 07801
1	Commanding General U.S. Army Materiel Command ATTN: AMCRD-TE Washington, DC 20315	6	Commanding Officer U.S. Army Frankford Arsenal ATTN: Dr. S. Ross SMUFA-Lib SMUFA-J7700, Mr. F. Shinaly SMUFA-J8000, Mr. J Mitchell SMUFA-J9000, Mr. W. Davis SMUFA-J1100, Mr. H. Rosenberg Philadelphia, Pennsylvania 19137
1	Commanding General U.S. Army Aviation Systems Command ATTN: AMSAV-E 12th & Spruce Streets St. Louis, Missouri 63166	2	Commanding Officer U.S. Army Picatinny Arsenal ATTN: SMUPA Mr. W. Painter SMUPA-VC2, Mr. G. Demitrack Dover, New Jersey 07801
1	Commanding General U.S. Army Electronics Command ATTN: AMSEL-DL Fort Monmouth, New Jersey 07703		
1	Commanding General U.S. Army Missile Command ATTN: AMSMI-R Redstone Arsenal, AL 35809		

DISTRIBUTION LIST

<u>No. of Copies</u>	<u>Organization</u>	<u>No. of Copies</u>	<u>Organization</u>
3	Commanding General U.S. Army Weapons Command ATTN: AMSWE-RE AMSWE-RDF AMSWE-RES Rock Island, Illinois 61202	2	Commanding Officer U.S. Army Materials & Mechanics Research Center ATTN: AMXMR-ATL AMXMR-T Mr. F. Baratta Watertown, Massachusetts 02172
4	Commanding Genreal U.S. Army Weapons Command ATTN: AMSWE-REA AMSWE-RET AMCDM-R AMCPM-VRF Rock Island, Illinois 61202	1	Commanding General U.S. Army Natick Laboratories ATTN: AMXRD, Dr. D. Sieling Natick, Massachusetts 01762
3	Commanding Officer U.S. Army Watervliet Arsenal ATTN: SWEWV-RD, Dr. Weigle SWEWV-RDD, Mr. V. Preska Mr. F. John Watervliet, New York 12189	1	HQ DA (DACS-CW) Washington, DC 20310
1	Director U.S. Army Advanced Materiel Concepts Agency 2461 Eisenhower Avenue Alexandria, Virginia 22314	1	HQ DA (DARD-ARP) Washington, D.C. 20310
1	Director U.S. Army Air Mobility Research & Development Laboratory Ames Research Center Moffett Field, California 94035	1	Commanding Officer U.S. Army Research Office (Durham) ATTN: Dr. Kumar Box CM Duke Station Durham, North Carolina 27706
1	Commanding Officer U.S. Army Harry Diamond Laboratories ATTN: AMXDO-TD/002 Washington, DC 20438	1	Department of Ordnance U.S. Military Academy ATTN: Assoc Prof West Point, New York 10996
		1	University of Michigan Department of Mechanical Engineering ATTN: Prof J. Shigley Ann Arbor, Michigan 48104
		3	Commander U. S. Naval Air Systems Command ATTN: AIR-604 Washington, DC 20360

DISTRIBUTION LIST

<u>No. of Copies</u>	<u>Organization</u>
3	Commander U. S. Naval Ordnance Systems ATTN: ORD-9132 Washington, DC 20360
	<u>Aberdeen Proving Ground</u>
	Chief, Tech Lib Marine Corps Ln Ofc CDC Ln Ofc Co, USASASA ATTN: Mr. Ambrosini (2 cy)

DOCUMENT CONTROL DATA - R & D

(Security classification of title, body of abstract and indexing annotation must be entered when the overall report is classified)

1. ORIGINATING ACTIVITY <i>(Corporate author)</i> U. S. Army Aberdeen Research and Development Center Ballistic Research Laboratories Aberdeen Proving Ground, Maryland		2a. REPORT SECURITY CLASSIFICATION Unclassified	
		2b. GROUP	
3. REPORT TITLE THE DYNAMICS OF CAM SYSTEMS FOR GUN MECHANISMS			
4. DESCRIPTIVE NOTES <i>(Type of report and inclusive dates)</i>			
5. AUTHOR(S) <i>(First name, middle initial, last name)</i> Herman P. Gay			
6. REPORT DATE April 1972		7a. TOTAL NO. OF PAGES 23	7b. NO. OF REFS 2
8a. CONTRACT OR GRANT NO.		9a. ORIGINATOR'S REPORT NUMBER(S) Memorandum Report No. 2177	
b. PROJECT NO. ITOG1102A33C			
c.		9b. OTHER REPORT NO(S) <i>(Any other numbers that may be assigned this report)</i>	
d.			
10. DISTRIBUTION STATEMENT Approved for public release; distribution unlimited.			
11. SUPPLEMENTARY NOTES		12. SPONSORING MILITARY ACTIVITY Commanding General Army Materiel Command Washington, DC 20315	
13. ABSTRACT A general method is described for calculating the dynamics of systems that include cams and followers. The method is especially suited to the analog computer. Since the analog computer has proven to be an effective tool for simulating automatic gun mechanisms and, since cams and followers generally are a part of those mechanisms, this method can be used to establish a more detailed and complete simulation. Two spring-mass systems coupled through a cam are simulated to illustrate the method. Clearance between the follower and the cam track can be included without complexity.			

14. KEY WORDS	LINK A		LINK B		LINK C	
	ROLE	WT	ROLE	WT	ROLE	WT
Cam Analog Simulation Dynamics						