

# ENGINEERING EXPERIMENT STATION

AD743106

## THE EFFECT OF MATERIAL PROPERTIES ON MATERIALS HANDLING PROCESSES

by

R. W. Christensen, R. W. Heins,  
W. Babcock and R. Tonn

ARPA Order No. 1579, Amendment No. 2  
Program Code No. 1F10  
Contract No. H0210005



Produced by  
NATIONAL TECHNICAL  
INFORMATION SERVICE  
Springfield, Va. 22151

DISTRIBUTION STATEMENT A  
Approved for public release;  
Distribution Unlimited

36

**BEST  
AVAILABLE COPY**

Mar 7, 66

## DOCUMENT CONTAINING DATA - R I D

Security classification of this report and abstract and other information must be entered when the overall report is classified

1. ORIGINATING AGENCY (Agency name and number)

University of Wisconsin  
Engineering Experiment Station  
Madison, Wisconsin 53706

2a. REPORT SECURITY CLASSIFICATION

Unclassified

2b. GROUP

3. REPORT TITLE

The Effects of Material Properties on Materials Handling Processes

4. DESCRIPTIVE NOTES (1, 2, 3 of 10) (at and inclusive dates)

Annual Technical Report

5. AUTHOR(S) (Last name, middle initial, first name)

R. W. Christensen, R. W. Heins, W. Babcock and R. Tonn

6. REPORT DATE

April, 1972

7a. TOTAL NO. OF PAGES

30

7b. NO. OF REFS

6

8a. CONTRACT OR GRANT NO.

H0210005

b. PROJECT NO.

1579

c. Program Code No. 1F10

9a. ORIGINATOR'S REPORT NUMBER(S)

144-B639

9b. OTHER REFS BY AGENCY (Any other numbers that may be attached to this report)

10. DISTRIBUTION STATEMENT

Distribution of this document is unlimited.

11. SUPPLEMENTARY NOTES

12. SPONSORING MILITARY ACTIVITY

Advanced Research Projects Agency  
Washington, D. C. 20301

13. ABSTRACT

In order to achieve a better understanding of the fundamental aspects of materials handling by a conveyor system, a model system is being constructed. Among the major problems to be dealt with are those which result from scaling down from the full size unit. A statistical experimental design has been set up to evaluate the actions and interactions between the variables. This should lead to a minimum amount of experimental tests.

As an aid in this evaluation, simulation of vertical acceleration of the material due to belt movement has been carried out and the results are reported. Plans for two additional simulators are presented which may better reproduce particle agitation.

Physical properties of three samples acquired from tunnelling projects in Milwaukee, Wisconsin and White Pine, Michigan have been run and are reported. ( )

DD FORM 1473  
1 NOV 65

Security Classification

SECURITY INFORMATION

| 14. | REF NUMBER   | LINE A |    | LINE B |    | LINE C |    |
|-----|--|--------|----|--------|----|--------|----|
|     |  | ROLL   | WT | ROLL   | WT | ROLL   | WT |
|     | Conveyor simulation<br>Particle agitation<br>Vertical acceleration<br>Conveyor systems<br>Statistical experimental design<br>Material properties<br>Rapid excavation |        |    |        |    |        |    |

ANNUAL TECHNICAL REPORT

MARCH 1972

THE EFFECT OF MATERIAL PROPERTIES ON MATERIALS HANDLING PROCESSES

by

R. W. Christensen and R. W. Heins  
Co-Principal Investigators

Telephone (608) 262-3225  
(608) 262-2563

Department of Engineering Mechanics  
and the  
Department of Metallurgical and Mineral Engineering  
The University of Wisconsin  
Madison, Wisconsin 53706

Sponsored by

Advanced Research Projects Agency  
ARPA Order No. 1579, Amendment No. 2  
Program Code No. 1F10  
Contract Period: January 29, 1971 through January 28, 1972  
Amount of Contract: \$42,715

This research was supported by the  
Advanced Research Projects Agency  
of the Department of Defense and was  
monitored by the Bureau of Mines under  
Contract No. H0210005.

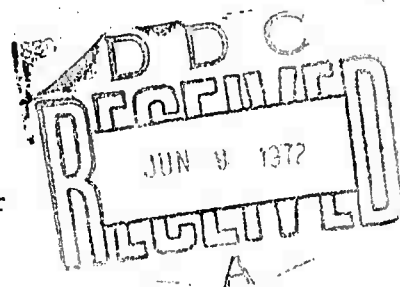

The views and conclusions contained in this document are those of the authors and should not be interpreted as necessarily representing the official policies, either expressed or implied, of the Advanced Research Projects Agency or the U. S. Government.

DISTRIBUTION STATEMENT A

Approved for public release  
Distribution Unlimited

## CONTENTS

|   |    |
|---|----|
| Summary.....  | 1  |
| Introduction.....   | 1  |
| Equipment Design.....                                       | 2  |
| Scaling.....  | 4  |
| Vertical Vibration Tests.....                               | 6  |
| Experimental Design.....                                    | 13 |
| Variables being considered.....                             | 13 |
| Procedure.....  | 14 |
| Physical Property Determinations of Excavated Material..... | 15 |
| References.....   | 18 |

## TABLES

|  |    |
|--|----|
| 1. Flowability - Angle of surcharge - Angle of repose..... | 3  |
| 2. Summary of Vertical Vibration Test Results.....         | 9  |
| 3. Summary of Physical Properties Tests.....               | 17 |

## ILLUSTRATIONS

|  |  |
|--|--|
| Fig. 1 Model test conveyor (in foreground).....  |  |
| Fig. 2 Return conveyor.....  |  |
| Fig. 3 Typical idler assemblies.....   |  |
| Fig. 4 Container for vertical vibration tests.....   |  |
| Fig. 5 Container mounted on vertical vibration machine.....                                  |  |
| Fig. 6 Bulk material at angle of repose prior to testing.....                                |  |
| Fig. 7 Bulk material after testing. Note segregation by particle size.                       |  |
| Fig. 8 Pantograph for determining cross sectional profile of bulk<br>material.....           |  |
| Fig. 9 Typical cross section after vibration test at indicated test<br>conditions.....       |  |
| Fig.10 Typical cross section after vibration test at indicated test<br>conditions.....       |  |
| Fig.11 Mechanical simulator.....   |  |
| Fig.12 Mechanical simulator.....   |  |
| Fig.13 Grain size distribution.....  |  |
| Fig.14 Stress as a function of strain during shear test of<br>Milwaukee Tunnel material..... |  |
| Fig.15 Mohr diagram for Milwaukee Tunnel material.....                                       |  |

## SUMMARY

Although physical properties of bulk materials influence their conveying in all materials handling systems, the emphasis in this study is related to rapid excavation during tunnelling. In order to achieve the materials handling capabilities required, a better understanding of the fundamental aspects of the materials-system interface and interactions must be obtained. In particular, the effect of the physical properties of excavated material on the handling system must be investigated. The selection of equipment based on experience, tradition, or intuition is no longer valid but must be based in part on an analysis of the physical properties of the material to be handled.

The purpose of this research is to identify the variables which control the material handling processes. It is the hope of this research team that optimum material characteristics will be found, which will enhance handling output. Since these materials are the products of extraction and essentially man-made, it should be possible to modify their properties at or near the face of excavation to improve their handleability.

A model belt conveyor system is being constructed to study the effect of material properties on equipment. The model (scaled) system is about one-third the standard 24-inch wide full size machine. The choice of scale was based largely on the problems associated with acquisition, storage, and utilization of huge bulk samples if a full size system were adopted. Scaling, however, leads to many other problems which remain to be solved.

A discussion on the experimental design approach to experimentation is presented in which the more important variables are listed. Using this approach, main effects and interaction between variables can be isolated and determined with a minimum amount of experimentation.

In addition to the development of a model conveyor system, a series of vertical vibration tests, designed to simulate the motion of bulk material on a conveyor belt, has been initiated. Preliminary results of this testing program have been obtained and are reported herein.

The physical properties obtained from samples of excavated material from three tunnelling operations have been run and are reported.

# THE EFFECT OF MATERIAL PROPERTIES ON MATERIALS HANDLING PROCESSES

by

R. W. Christensen, R. W. Heins,  
W. Babcock and R. Tonn

## INTRODUCTION

The advent of large diameter tunnelling machines marks a new era in tunnelling practice. While these machines are capable of excavating hard rock rapidly and continuously, new designs of even greater capacity are being developed and tested. Rapid excavation underground, at rates never before dreamed of, appears to be just around the corner. For example, a revolutionary piece of equipment in prototype form which has recently undergone tests by the military has a theoretical production of 150,000 cubic yards of material per hour (6)<sup>4</sup>. This is an astounding rate of production of material all of which must be moved from the machine efficiently and without delay. The problems of materials handling associated with rapid excavation processes are enormous.

The present tunnelling machines are an outgrowth of the continuous mining machines developed in the early 1950's by the coal producers. In need of high productivity per man hours, these companies fostered the development of continuous mining machines which literally ripped the coal from the face. These machines also were equipped with loading devices that moved the material away from the face and onto an extensible belt conveyor or to a shuttle car behind the miner. These same machines were subsequently successfully used in soft rock, for example, potash.

Having been shown that continuous mining equipment was practical, the manufacturers began working on systems where rock with increasingly higher compressive strengths could be mined continuously. The present continuous excavator represents a breakthrough in that rocks having compressive strengths in excess of 25,000 pounds per square inch (psi) can now be excavated by machine. Tunnelling no longer suffers the constraints of the cyclic drill-blast method.

The volume of rock fragmented by these machines is largely a function of the speed of the cutting head and the rate of the machine's advance. A number of cutter designs have been proposed and tried in practice. These designs have drawn heavily on the technological advances made in drilling oil wells. The particle size distribution and particle shape of an excavated material are, in part, dependent on the type of cutter used as well as the relative strength of the material in place. The linear cutter or disk cutter as applied in soft to medium hard formations produces larger particles or chips which tend to be plate-like in shape. In contrast, the tungsten carbide insert cutter which is used in very hard formations tends to produce

---

<sup>4</sup>Underlined numbers in parentheses refer to items in the list of references at the end of this report.

fine chips of more equal dimensions. Thus, it can be seen that both cutter design and rock strength influence chip shape and size distribution and can be controllable variables if it were shown that these properties had an important influence on the materials handling problem.

While it is quite speculative at this point, an attempt is being made to determine the influence of such material properties as particle shape, particle size distribution, angle of internal friction, and moisture content on the way these materials behave on a conveyor belt. If this effort proves successful: Materials handling systems might be designed around those properties and variables which are shown to be important in the handling process; most of the variables mentioned are controllable and might be changed, if such changes make the handling problem any easier and; an optimum combination of handling system design and materials property changes might be utilized.

### EQUIPMENT DESIGN

The effects of bulk material characteristics must be considered in the design of belt conveyor systems. In terms of performance in belt conveyor systems, the following material characteristics must be considered:

Angle of Repose - The angle which the surface of a normal, freely formed pile makes to the horizontal.







Angle of Surcharge - The angle to the horizontal which the surface of the material assumes while the material is at rest on a moving conveyor belt.

Flowability - The combined effect of the above characteristics on the behavior of the material on a belt conveyor. Table 1 illustrates the flowability for a range of material types.

These three interrelated characteristics are, in turn, dependent on more basic material properties as well as the dynamic effects imparted to the material by the conveyor. Basic material properties which could have an effect are particle-size distribution, abrasiveness, density, internal friction, and cohesiveness.

The material will remain at the angle at which it was placed on the belt until conditions of loading are changed significantly. The angle at which the material is placed will be something less than the angle of repose because of the dynamic effect of placement on the moving belt. Where dynamic effects are not minimized, this operation may overshadow all other forces acting on the material and govern the amount of material that the belt can handle.

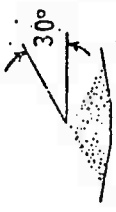
Any significant change in loading conditions, will tend to reduce the angle of surcharge. These loads could also influence material characteristics such as moisture content. The loads imparted to the bulk material after placement on the belt are dynamic loads transmitted to the material by the conveyor. The type and magnitude of this loading is a function of belt speed, sag, tension, inclination, and ambient vibration. A fundamental factor here is the vertical acceleration of the material due to the belt displacement as it moves over the idlers.

| TABLE 1. - FLOWABILITY-ANGLE OF SURCHARGE-ANGLE OF REPOSE (2)  |   |   |  |   |
|--|---|---|--|---|
| Very Free Flowing 1*   | Free Flowing 2*   | Average Flowing 3*  | Sluggish 4*  | Profile on Flat Belt  |
| 5° Angle of Surcharge<br> | 10° Angle of Surcharge<br> | 20° Angle of Surcharge<br> | 25° Angle of Surcharge<br> | 30° Angle of Surcharge<br> |
| 0°-20° Angle of Repose   | 20°-30° Angle of Repose   | 30°-35° Angle of Repose   | 35°-40° Angle of Repose  | 40°-Up Angle of Repose  |
| Other Angles of Repose   |   |   |  |                            |

MATERIAL CHARACTERISTICS

|   |   |  |  |  |  |
|---|---|--|--|--|--|
| Uniform size, very small rounded particle, either very wet or very dry, such as-dry silica sand, cement, wet concrete, etc. | Rounded, dry polished particles, of medium weight, such as whole grain and beans. | Irregular, granular or lumpy materials of medium weight such as anthracite coal, cottonseed meal, clay, etc. | Typical common materials such as-bituminous coal, stone, most ores,-etc. | Irregular, stringy fibrous, interlocking materials, such as wood chips, bagasse, tempered foundry sand, etc. | May include any characteristic shown in designations 1 thru 4. |
|---|---|--|--|--|--|



Reproduced from best available copy.

To properly assess these considerations a test conveyor is being constructed. Two approaches to experimentation were considered: (1) use of a full size conveyor section, or (2) use of a scaled version. The latter was chosen for use as the test facility.

The full size version offered the advantage of obtaining easily correlated empirical data involving no scaling effects on the material. While components for such a facility were more readily available than for the scaled version, housing a facility of that size in addition to the problems of procuring and handling the large volumes of representative materials from rapid excavation sites was prohibitive.

The model conveyor overcomes the physical problems mentioned, but created problems of scaling and construction. The belt width was arbitrarily set at 8". For laboratory study, overall size and weight were important considerations. In order to meet the experimental design requirements, many adjustments were necessary. Making the equipment adjustable and compact caused construction problems which have subsequently been solved.

#### Scaling

In the design of the model conveyor system, the scaling factors for the conveyor and the material must be determined. Scaling problems relative to belt flexibility and idler spacing in relation to the material load being carried by the belt must be solved. Our studies to date indicate that, for a given material, the controlling factor determining the behavior of the material on the conveyor is the vertical acceleration experienced by the material as it travels along the belt. The problem, then is to design the model conveyor with a vertical acceleration pattern imparted to the material similar to that which it would experience on a full-sized conveyor.

The vertical acceleration imparted by a conveyor to the material being handled is a function of belt speed and the deformed shape of the belt under load. The deformed shape of the belt is, in turn, a function of the weight of material being carried, idler spacing, belt flexibility, and belt tension. In order to model the full scale operation as closely as possible, it is anticipated that belt speeds used in the tests will be the same as for full sized conveyors. Therefore, since the load of the material being carried on the model conveyor will be a small fraction of that carried by a full sized conveyor, it is apparent that the belt used on the model conveyor will have to be considerably more flexible than full sized belts. Furthermore, idler spacing will be reduced in the test section which will require greater flexibility in order to keep the deformed shape of the belt similar to that of a full sized conveyor. A reduction in belt tension also can be used to achieve the same purpose. By appropriate scaling of the various factors involved, it should be possible to model the material handling characteristics with a small scale version of the conveyor system.

For any material; cohesion, abrasiveness, and particle size present the major potential scaling problems; the angle of repose and angle of internal friction do not depend upon scale. Since the materials being considered in this study are fine sized, most of the cohesive properties that may be present would be due to capillary effects, although some cohesion due to electrostatic effects may be present in the very fine-grained fraction. It appears doubtful that cohesion, whether due to capillary or electrostatic effects, will be present to any significant degree in either the full sized or the model conveyor systems; capillary cohesion will probably be destroyed by disturbances to the material during the handling process and cohesion due to electrostatic attraction would be present in only the very fine-grained fraction which represents only 5 to 10 percent of the total sample.

Abrasive wear on the conveyor belt appears to be a difficult factor to scale. Experience with full sized conveyor systems indicates that a majority of belt wear takes place upon impact of the material as it is being loaded onto the belt. Some additional wear may occur anywhere there is sliding of the material relative to the belt. In either case, the amount of wear is a function of the weight of material involved and the wearing qualities of the belt. It is impractical to modify the wearing qualities of the belt to account for the reduction of the weight of material in the model system. But, it should be possible to assess belt wear for various test conditions and materials on a relative scale, even though the amount of wear will not be the same as in the full sized system.

The particle size distribution of the material also must be appropriately scaled for the model system. Particle size distribution can be expected to influence such factors as angle of surcharge, loss of material from the belt during handling and the force of impact when the material is loaded onto the belt. To be strictly correct, the entire particle size distribution should be altered in accordance with the reduction in belt width, and the differences in the loading operation between the full sized conveyor and the model conveyor so as to properly account for loss of material during handling and impact force. However, this also would alter the angle of surcharge and the amount of cohesion present in the sample. Therefore, as a first approximation, it is planned to merely eliminate the larger sized particles while keeping the remainder of the particle size distribution unchanged. The intent will be to maintain a constant ratio of maximum particle size to belt width. For example, if the maximum particle size to be carried on a 24-inch belt is 3 inches, a maximum particle size of 1 inch would be used on an 8-inch belt. This method of scaling should eliminate excessive loss of material from the belt without introducing undesirable changes in the fundamental material properties.

Construction of the model conveyor is nearing completion at the time of writing. Fig. 1 shows the test section as of March 13, 1972. The conveyor frame is adjustable in inclination from  $0^{\circ}$  to  $20^{\circ}$ . The test section will be 20' long with 8" belt width. The drive assembly will have a variable conveyor belt speed of 50-700 fpm and will be driven by a 5 hp. open, drip-proof D.C. motor through V-belt drive pulleys.

The return unit in the closed loop system is a 26' conveyor section with 18" belt width constructed from standard components. The return section will operate at a constant speed of 200 fpm. The return section is shown in Fig. 2. Transfer of material between the model conveyor and the return section will be through chutes and bin-hoppers.

The idler assemblies for the model conveyor have a bracket mount much like their full size counterparts. Originally, an idler assembly with completely adjustable troughing angles was envisioned; however, this was found to have many drawbacks in construction and design with no real benefit in that the experimental design requires only certain limits of operation. The brackets may easily be interchanged for desired troughing angles. Troughing of 20°, 35° and 45° is currently provided for. Fig. 3 shows the idler assemblies being used.

These idlers are provided with sealed ball bearings pressed into the roller. Other, more economical bearing types, such as teflon were investigated, but did not withstand the loads and speeds required. Idler assemblies may easily be moved longitudinally to change the idler spacing.

Belting for the conveyor is of the Goodyear polyester series with a rough top. The 2-ply belt has a tensile rating of 80#/inch of width. Because of the high troughing angle, narrow belt width, relatively short idler spacing and low belt loads, a highly flexible belt material was needed. All existing belts in the standard bulk material conveyor line were much too stiff, so a belt intended for less severe wear conditions is being used; thus rapid belt wear is anticipated but unavoidable.

#### VERTICAL VIBRATION TESTS

Another approach to the experimental phase of this study has been developed; it is concerned with the simulation of particle agitation on a conveyor belt by means of vertical vibration tests. The purpose of this testing program is two-fold. Considerations of scaling factors indicated that vertical motions experienced by the material on the belt is a fundamental factor determining the handling characteristics. Secondly, constructing an efficient experimental design requires preliminary knowledge of the variables, their possible ranges, and interactions with other variables. The resulting fractional factorial design which is constructed will eliminate confusion in the following analysis. Therefore, a distinct advantage can be gained in the testing program, if the most common variables can be studied in a simple simulation prior to the actual test on the model conveyor.

Vibrations transmitted to the material result from the deforming shape of the moving, loaded belt. This deformation is a function of belt speed, idler spacing, belt sag, idler quality and ambient vibrations transmitted through the supporting frame. The frequency and amplitude of the prominent vibrations can be calculated if the belt speed, idler spacing, belt tension, and weight of material on the belt are known. Ambient vibrations cannot be calculated, but could be monitored during operation of a conveyor.

Three methods of simulation will be presented. The first of these simulations has been run and results are shown. The remaining two are in the design stage.

In the first method a container for the material was designed to simulate the geometry of a conveyor belt cross-section. It has a flat center section and adjustable sloping sides. The sides can be adjusted to simulate 20°, 35° and 45° troughing. A 12 inch long container was fabricated from 1/4" aluminum plate stock and was lined with belt material 8 inches wide. The ends of the container are vertical and the sides are somewhat wider than the belt itself to prevent spillage during the tests (see Fig. 4). Thus, the container simulates a short length of a typical conveyor cross-section on a small scale.

In the initial stage of testing, an attempt has been made to bracket the probable range of frequency and displacement likely to be experienced by the material in typical conveyor designs. For these initial tests, a range of frequency from 0 to 50 cycles per second was selected and the displacements were gradually increased to the point where the material became severely agitated. This behavior was considered to be the practical limit both in terms of the tests themselves and a full scale conveyor operation.

The material for the tests consists of 1.5 pounds of the bulk material obtained from tunnelling operations as described subsequently in this paper. The samples passing a #4 sieve size, in an air-dried condition, were prepared at a moisture content of 5 percent to prevent dusting which could be detrimental to the testing apparatus.

The vibration testing apparatus, a 1200-lb. MB-electromagnetic shaker (Model C10), is shown in Fig. 5. It is capable of producing frequencies from 0 to 10,000 cycles per second and displacements from 0 to approximately 1/2 inch depending upon the mass of the sample and the frequency being used. The apparatus can be programmed for either sinusoidal or random motions. In the initial series of tests, sinusoidal motions were used; however, for future testing, the possibility of including random motions is being considered. The vibrations of an operating conveyor system may be monitored in an attempt to improve the testing procedures by closer approximation of actual vibrations.

Prior to the start of each test, the bulk material is placed at the angle of repose. It is then subjected to vertical vibration at the desired frequency and amplitude for a period of 30 seconds (this test duration was more than adequate to achieve a "steady-state" condition in the material in all cases). Figure 6 shows the bulk material in the container at the angle of repose prior to testing. Figure 7 was taken after the test, in this case, the vibration rate was 30 cycles/second, the displacement was 0.05", and the vertical acceleration was 2.3g. Comparison of these photographs illustrates the segregation of the particles by size. During the test, the degree of disturbance in the material is noted in terms of particle size segregation, alteration of the initial cross-section of the sample, severity of agitation, etc. At the end of the test, the cross-section profile of the sample is plotted using a pantograph designed and built specifically for these tests (see Fig. 8).

Depending upon the frequency and amplitude of motion, the effect on the sample cross-section varied from no discernable change to complete destruction of the cross-section; i.e., zero angle of surcharge. A description of each test is provided in Table 2. Figures 9 and 10 also show two typical sample cross-sections measured at the end of the tests. The trends observed in the initial series of tests may be summarized as follows:

- (1) At very low frequencies, relatively large amplitudes could be tolerated before significant alteration of the sample cross section occurred.
- (2) As the frequency increased, less amplitude was needed to alter the cross section (i.e., reduce the angle of surcharge).
- (3) At frequencies of 35 cycles per second and higher, a resonant condition appeared to develop (at the higher amplitudes) and the material exhibited a fluid-like behavior.
- (4) Close examination of the data indicates that peak vertical acceleration is the major factor controlling the ultimate angle of surcharge achieved by the material when subjected to vertical vibration; i.e., below about 1.5g vertical acceleration the sample cross section changes relatively little from the static angle of repose, whereas, above 1.5g the angle of surcharge decreases rapidly. Thus, there is a strong indication that peak vertical acceleration is a very important parameter in the performance of bulk materials on conveyor belts.

High speed photography was employed during a selected few vibration tests to study the time history of particle motions during the tests. Film speeds of 750 and 1500 frames per second were used. These films indicate that the larger particles are affected more than the finer particles by the vertical acceleration. Larger particles work their way up to the surface, emerge, and tumble down the slope, giving the segregation shown in Fig. 7.

Based on a preliminary study of the films, it is evident that a film speed of 750 frames per second adequately shows the vibration test and the destruction of the material profile. It is possible to count the number of vibrations necessary to alter the material cross section by viewing the film. The whole process is clearly visible and filming appears to offer a good test evaluation technique.

The second simulator is an attempt to better account for the agitation of material at the idler. The previous simulation fails to take into account the squeezing action of the belt on the material as it approaches the idler, the "breaking" of the belt as it passes over the idler, and the release as the material moves away from the idler when the belt flattens between idlers. Fig. 11 shows a simulator which attempts to account for these effects.

Milwaukee Tunnel Material - Dolomite Limestone  
 Troughing Angle = 45°

| Frequency (CPS) | Double Amplitude (inches)            | Acceleration (g)             | Remarks  |
|-----------------|--------------------------------------|------------------------------|--|
| 6               |                                      |                              | No visual movement of particles up to 0.5" displacement  |
| 10              | 0.20<br>0.24<br>0.26<br>0.28         | 1.00<br>1.25<br>1.38<br>1.50 | Movement of a few individual particles<br>Relatively little disturbance<br>Destruction of shape of cross-section<br>Destruction of shape of cross-section                |
| 15              | 0.1<br>0.12<br>0.14                  | 1.15<br>1.40<br>1.65         | Very small amount of disturbance<br>Small disturbance<br>Mild disturbance to cause slippage of sample downbelt (rotation)  |
| 20              | 0.04<br>0.08<br>0.10                 | 0.86<br>1.70<br>2.1          | Movement of a few individual particles<br>Disturbance, stones fell off slopes. Some settling occurred<br>Large disturbance, most stones along sides, rotational slippage |
| 25              | 0.04<br>0.08                         | 1.3<br>2.6                   | Small disturbance down slopes<br>Large disturbance, boiling of stones from bottom to top, settling   |
| 30              | 0.02<br>0.04                         | 0.93<br>1.85                 | Movement of a few individual particles<br>All stones moved to sides. Some shifting or rotational slippage  |
| 35              | 0.02<br>0.04<br>0.04 (one day later) | 1.25<br>2.5<br>2.5           | Constant particle movement, some flattening of material<br>Almost uniformly flat along testing box<br>Nearly flat, negligible rotational slippage at ends                |
| 40              | 0.01<br>0.02<br>0.04                 | 0.83<br>1.66<br>3.3          | Movement of a few individual particles<br>Particles agitate. Center settled but ends retained some shape<br>Flattening completely all along device                       |
| 45              | 0.01<br>0.02                         | 1.05<br>2.10                 | Small continual movement (agitation)<br>Slopes flatten with some pitch visible   |
| 50              | 0.01<br>0.02                         | 1.3<br>2.6                   | Particle movement in center half where ends retained some shape<br>Flattens completely   |

Table 2a - Summary of Vertical Vibration Test Results (continued)

Milwaukee Tunnel Material - Dolomite Limestone  
Troughing Angle = 20°

| Frequency (CPS) | Double Amplitude (inches)            | Acceleration (g)                     | Remarks  |
|-----------------|--------------------------------------|--------------------------------------|--|
| 6               |                                      |                                      | No visual movement of particles up to 0.5 inch displacement  |
| 10              | 0.20<br>0.24<br>0.26<br>0.28<br>0.32 | 1.0<br>1.25<br>1.38<br>1.50<br>1.63  | No movement<br>Small disturbance. Some settlement<br>Beginning of rotational failure. Rounding of ridge<br>Rotational failure. Settling of slopes<br>Flattening of cross-section. Some segregation |
| 15              | 0.10<br>0.12<br>0.14<br>0.16<br>0.18 | 1.15<br>1.40<br>1.65<br>1.90<br>2.10 | No movement<br>No movement<br>Uniform rounding of cross-section. Some segregation<br>Longitudinal cracking in center. Segregation occurs<br>Complete destruction. Rotation occurring               |
| 20              | 0.04<br>0.06<br>0.08<br>0.10         | 0.86<br>1.25<br>1.70<br>2.10         | No movement<br>Minimal movement<br>High segregation. Flattening of cross-section<br>Resonance  |
| 25              | 0.06                                 | 1.95                                 | Resonance  |

Table 2b - Summary of Vertical Vibration Test Results

White Pine - Sample No. 1 - Freda Sandstone  
Troughing Angle = 45°

| Frequency (CPS) | Double Amplitude (inches) | Acceleration (g) | Remarks   |
|-----------------|---------------------------|------------------|---|
| 6               |                           |                  | No visual movement of particles up to 0.5 inch displacement |
| 10              | 0.20                      | 1.00             | No movement   |
|                 | 0.24                      | 1.25             | No movement   |
|                 | 0.28                      | 1.50             | Movement of a few individual particles                      |
|                 | 0.32                      | 1.63             | Beginning of flattening                                     |
|                 | 0.36                      | 1.90             | Rounding of cross-section. Torsional destruction            |
| 15              | 0.14                      | 1.65             | Movement of a few individual particles                      |
|                 | 0.18                      | 2.10             | Rotational failure  |
| 20              | 0.10                      | 2.1              | Some flattening but holds shape                             |
|                 | 0.12                      | 2.5              | Rotational failure. Flattening but holds shape              |
|                 | 0.09-0.16                 | 1.9-3.4          | Rotational slippage slow to violent. Retains some shape     |

White Pine - Sample No. 1 - Freda Sandstone  
Idle Troughing Angle = 20°

|    |      |      |  |
|----|------|------|--|
| 10 | 0.20 | 1.0  | Initial movement only at beginning of test             |
|    | 0.28 | 1.5  | Uniform rounding. Small segregation (good test sample) |
|    | 0.32 | 1.63 | Rotational slippage. Considerable flattening           |
|    | 0.34 | 1.75 | Longitudinal cracking. Segregation. Uniform rounding   |
| 15 | 0.14 | 1.65 | Rounding. Beginning to rotate                          |
|    | 0.18 | 2.10 | Resonance  |
| 20 | 0.06 | 1.25 | Some movement of particles                             |
|    | 0.08 | 1.70 | Resonance - segregation of flattening                  |
| 25 | 0.04 | 1.3  | Begin rounding of cross-section                        |
|    | 0.06 | 1.95 | Resonance  |

Table 2c - Summary of Vertical Vibration Test Results

White Pine - Sample No. 2 - Nonesuch Shale  
Troughing Angle = 45°

| Frequency (CPS) | Double Amplitude (inches)    | Acceleration (g)             | Remarks  |
|-----------------|------------------------------|------------------------------|--|
| 6               |                              |                              | No visual movement of particles up to 0.5 inch displacement  |
| 10              | 0.26<br>0.30<br>0.32         | 1.38<br>1.53<br>1.63         | Some rounding of cross-section<br>Considerable flattening<br>Vibration causes material to become hard compacted                                |
| 15              | 0.15<br>0.16<br>0.18<br>0.20 | 1.80<br>1.90<br>2.10<br>2.30 | Some flattening of cross-section<br>Flattening of slope. Very compacted<br>Resonance. Almost flat. Rotational slippage along belt<br>Resonance |
| 20              | 0.10<br>0.12                 | 2.10<br>2.50                 | Flattening and rotation of cross-section<br>Resonance  |

White Pine - Sample No. 2 - Nonesuch Shale  
Idle Troughing Angle = 20°

|    |                      |                      |  |
|----|----------------------|----------------------|--|
| 10 | 0.26<br>0.30<br>0.34 | 1.38<br>1.55<br>1.80 | Beginning of rotation. Minimal settlement<br>Longitudinal cracking. Rounding of cross-section<br>Resonance. Cracks slap together. Particles fly around |
| 15 | 0.14<br>0.16         | 1.65<br>1.90         | Rounding. Some jumping of particles. Center jiggles.<br>Uniform rounding. Cracking. Jumping. Some compaction   |
| 20 | 0.08<br>0.10         | 1.70<br>2.10         | Some segregation. Considerable rounding. Compacting<br>Resonance. Complete flattening  |
| 25 | 0.06                 | 1.95                 | Resonance. Nearly flat. Segregation  |

The simulator consists of a length of stationary belt under which an idler assembly is passed, producing relative motion between the two.

The linear motion of the idler assembly is obtained from the rotational motion of the telescopic arms. The guide bar is always parallel to the belt axis and it constrains the swivel joint at the end of the telescopic arm to undergo linear displacement. The necessary radial adjustment is provided by the telescopic mechanism in the idler assembly arm. The linear velocity of the idler assembly can be considered as constant for all practical purposes. The use of rotational motion minimizes the inertia forces of the system and provides unidirectional linear motion with a relatively simple mechanism.

An increase in the rotational speed of the idler assembly telescopic arm unit is analogous to increase in the belt speed. The change in idler spacing is analogous to change in the spacing between belt clamps, and similarly belt tension.

The third simulator, shown in Fig. 12, takes into account the squeezing and release of the material as the belt passes over the idlers, but cannot simulate the "breaking" of the belt. This simulator will be used with the Materials Testing Service (MTS) machine. This machine has a more positive control of amplitude, frequency, and acceleration than the MB shaker used in the original vibration tests, particularly in the low frequency range. The MTS machine can also be programmed for any vertical motion desired; thus permitting the test sample to be submitted to a previously recorded vertical motion trace from an actual conveyor installation. Arrangements are in progress to obtain such a trace. The use of a programmed motion has obvious advantages over arbitrary frequencies, amplitudes, and motion patterns.

This simulator has the drawbacks that it does not account for the "breaking" of the belt and all vertical movement is accompanied by squeezing action because of the bell crank lever action. These shortcomings make the future of this simulator uncertain.

#### EXPERIMENTAL DESIGN

A tentative fractional factorial design has been developed for conducting the experimental investigation. This program is very flexible and variables can be added or deleted as necessary during the testing program. Regardless of the number of important variables that are finally formed in the testing program, this method of experimental design will optimize the amount of significant data obtained from a given number of experimental runs.

#### Variables Being Considered

The following list of variables is considered tentative as some may have to be added or deleted as testing progresses. The equipment variables that are being considered, but not limited to, are:

- $g_1$  = belt speed
- $g_2$  = belt inclination
- $g_3$  = change in inclination
- $g_4$  = cross section configuration of conveyor bed
- $g_5$  = belt material (coefficient of friction)
- $g_6$  = idler spacing
- $g_7$  = belt tension

The material variables that are being considered, but again not limited to, are:

- $q_1$  = particle size distribution
- $q_2$  = particle shape
- $q_3$  = angle of internal friction
- $q_4$  = moisture content

The total muck removal rate (V) is a function of the equipment and material variables:

$$V = f(g_1, g_2, g_3, g_4, g_5, g_6, g_7, q_1, q_2, q_3, q_4)$$

#### Procedure

The general procedure of setting up the factorial and fractional-factorial designs and of computing the results is well known(4). The first step in the experimental design procedure is to choose a high and low value for each test variable (since a two-level factorial or fractional factorial design will be used). It is assumed that any nonlinear relationships will not significantly affect the analysis. These values can be chosen from design manuals, manufacturing manuals, or from experimental models. Careful consideration should be used in selection since a good representative of high and low values will reduce the number of tests to be run.

After initial values have been assumed, the testing procedure, based on factorial or fractional factorial design, can be established. For example, assume seven test variables. A factorial design for seven variables would be  $2^7 = 128$  tests. On the other hand, for a fractional factorial design, the number of tests required is  $2^{7-4} = 2^3 = 8$ . The notation  $2^{7-4}$  indicates that each variable is studied at two levels, seven test variables are being studied, and four "new" variables (which are linear combinations of the original seven variables) have been added.

The advantage of fractional factorial designs over factorial designs is that the same number of tests (8) can be made for seven variables as can be made for the three variables in the factorial design. The data, however, is not pure as in the factorial design and involves interactions between variables. Therefore, the gain, in terms of the number of runs,

may be lost in confounding various combinations of the variables with each other. It is a matter of judgment as to what interactions and of what order can reasonably be ignored. Often the resulting data will provide an explanation of the interaction effects; if not, a systematic method for sorting out the interactions is available. Once the results have been evaluated, additional tests can be run to verify the interpretations for accuracy.

#### PHYSICAL PROPERTY DETERMINATIONS OF EXCAVATED MATERIAL

A sample of approximately 1000 pounds of material was obtained from a tunnel project in Milwaukee, Wisconsin. This sample was excavated by a Jarva machine and had essentially no particles larger than 1-1/2" (38 mm) sieve size with a high percentage passing the number 200 sieve. The particles were generally plate-like. The grain size distribution curve for this material is shown in Fig. 13. The specific gravity was determined to be 2.81. The material is probably a dolomitic limestone.

Two samples of 2400 pounds each were obtained from the White Pine Copper Company, White Pine, Michigan. Sample 1, which is a Freda Sandstone has angular particles, but not as distinctly plate-like as the Milwaukee sample. This material was excavated by a Robbins machine and had an approximate maximum particle size of 7" (180 mm). The specific gravity of this material was 2.77.

Sample 2 was a shale material with angular particles much like Sample 1, but upon drying became very weak along the bedding planes. This material has been identified as Nonesuch Shale. It is quite certain that the material was broken down somewhat due to the violent action of sieving. This material was excavated by a Atlas-Copco machine and had a maximum particle size of approximately 7 in. (180 mm). The specific gravity of this material was 2.83.

The materials were moist when obtained from the tunnel, but the moisture content in the as-received condition is not necessarily the natural moisture content of the material as it comes off the working face since the environment of the tunnel is quite damp. Furthermore, water is sometimes added to the bulk material to reduce dusting at the face. Therefore, no attempt was made to preserve or measure the moisture content of the sample in the as-received condition.

After air-drying, portions of the samples were sized on a Gilson shaker over a size range from 1-1/2 inches down to 200 mesh. The minus 200 mesh material was sized by the hydrometer method in the case of the Milwaukee material, however the White Pine samples did not have an appreciable amount of minus 200.

The specific gravity was determined in accordance with ASTM Designation D854-58(1). The rest of the tests were run on minus 4 mesh material. Samples used in the tests were blended in proportion to the size analysis. The minimum bulk density was determined by spooning the material into a 1/30 cubic foot mold. The maximum bulk density in this test was achieved by compacting seven layers with 50 blows each on the Proctor machine.

Vibration equipment was unavailable at the time of the test, and some destruction of larger grains was noted due to the compacting procedure. Because of this, maximum bulk density was not run on all samples.

Three direct shear tests were run using different normal stresses on each run. Fig. 14 is a plot showing the results of these tests. The machine was under stress control and the sample was in an air-dried state. Fig. 15 is a plot of the normal stress versus shear stress, and the angle of internal friction.  $\phi$ , was 53 degrees.

Only tests directly related to material handling were run on the White Pine samples. The results of the tests are shown in Table 3.

Table 3 - Physical Properties

|                                   | Milwaukee Tunnel Material<br>Dolomite Limestone | White Pine-Sample No.1<br>Freda Sandstone | White Pine-Sample No.2<br>Nonesuch Shale |
|-----------------------------------|---|---|--|
| Excavating Unit                   | Jarva   | Robbins                                   | Atlas - Copco                            |
| Size of Sample                    | 1000 lbs.                                       | 2400 lbs.                                 | 2400 lbs.                                |
| Approximate Maximum Particle Size | 1-1/2 inches                                    | 7 inches                                  | 7 inches                                 |
| Specific Gravity                  | 2.81  | 2.77                                      | 2.83                                     |
| Hygroscopic Moisture Content      | 0.5   | --  | --                                       |
| Angle of Internal Friction        | 53° (γ=115 pcf)                                 | --  | --                                       |
| Angle of Repose                   | 45°   | 44°                                       | 45°                                      |
| Bulk Density - Maximum            | 140.7   | --  | --                                       |
| Minimum                           | 95.7  | --  | --                                       |

## REFERENCES

1. American Society of Testing Materials, Standards, Part 4, 1958. Test D854-58.
2. American Society of Testing Materials, Standards, Part 4, 1963. Test D422-63.
3. Belt Conveyors for Bulk Materials, Conveyor Equipment Mfg. Association, Cahner's Publishing Co., Inc., 1966, p. 22.
4. Davies, Owen L., "Design and Analysis of Industrial Experiments," Hafner Publishing Co., New York, 1967.
5. Frisque, D. E. and Marraccini, L. C., "Physical Properties of Bulk Materials;" presented at seminar/workshop on Storage and Reclaiming of Bulk Solids, University of Pittsburgh, Pittsburgh, Pennsylvania, 1970.
6. Hayes, Major General T. J., from keynote speech, 2nd Symposium on Rapid Excavation, Sacramento College, Sacramento, California, 1969.

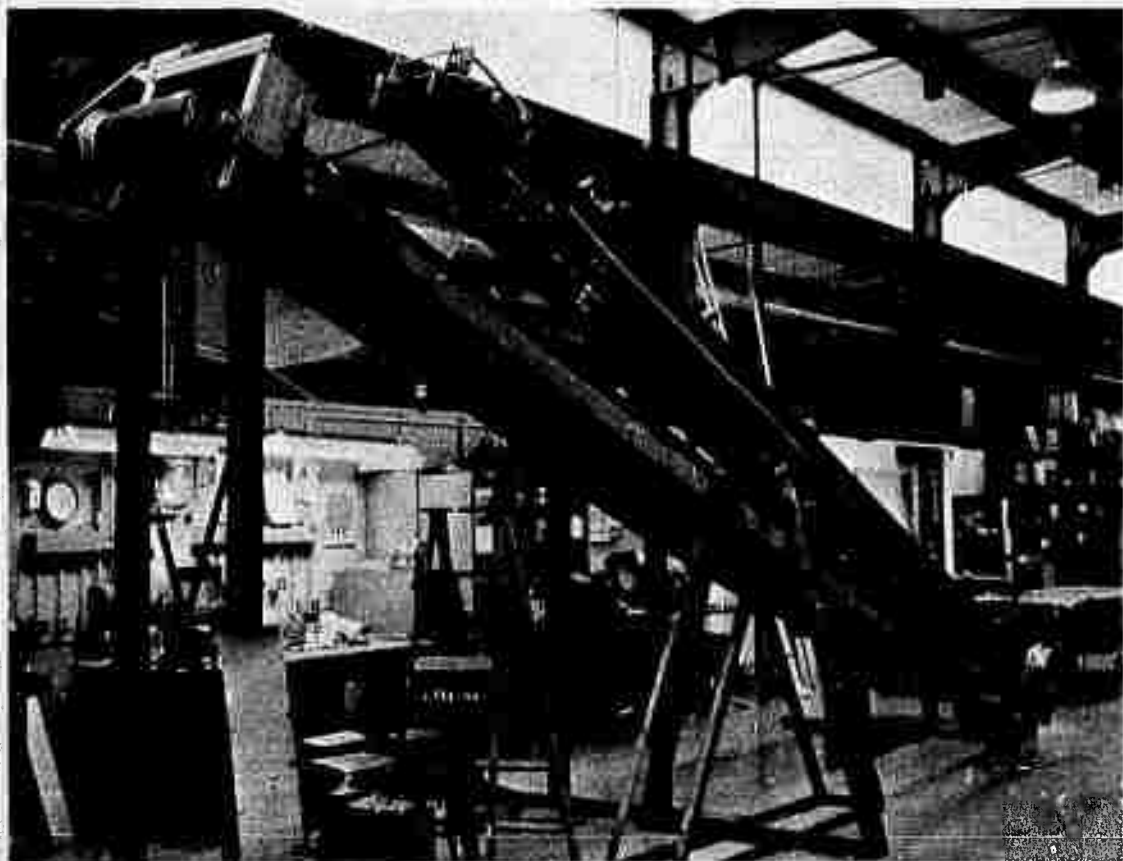
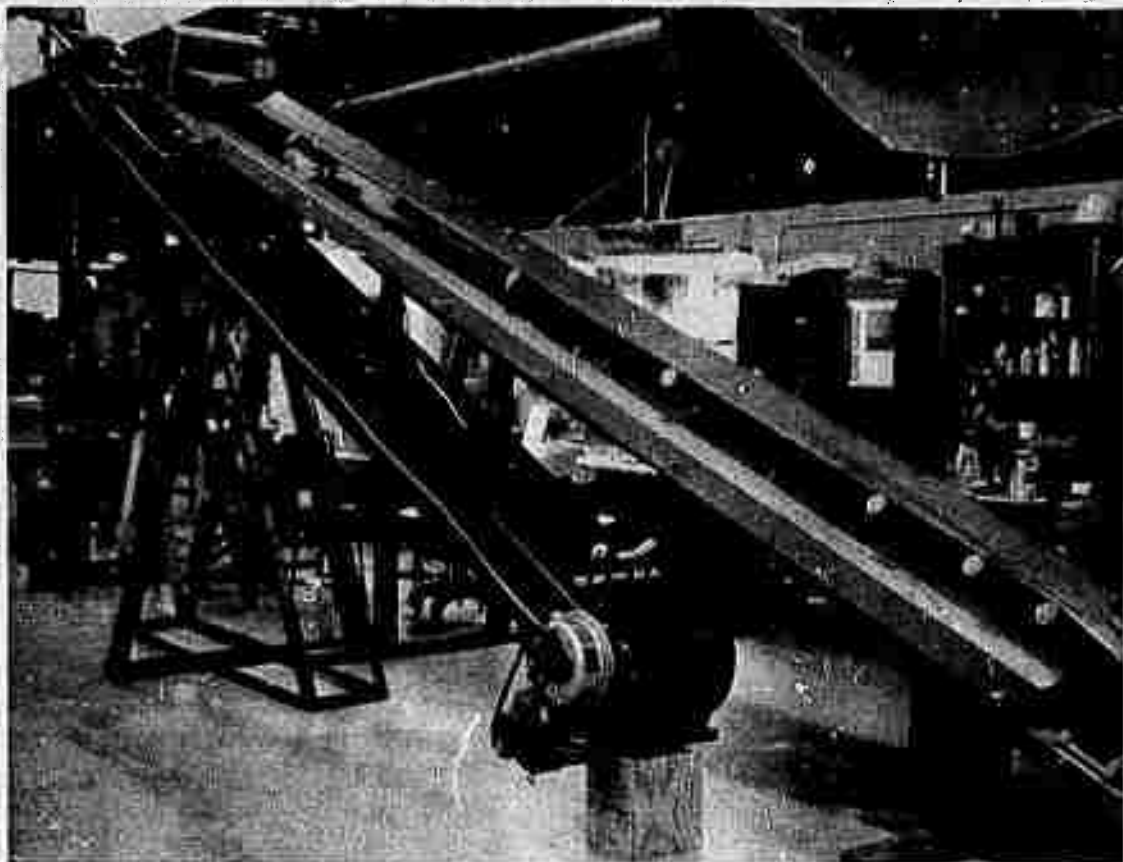

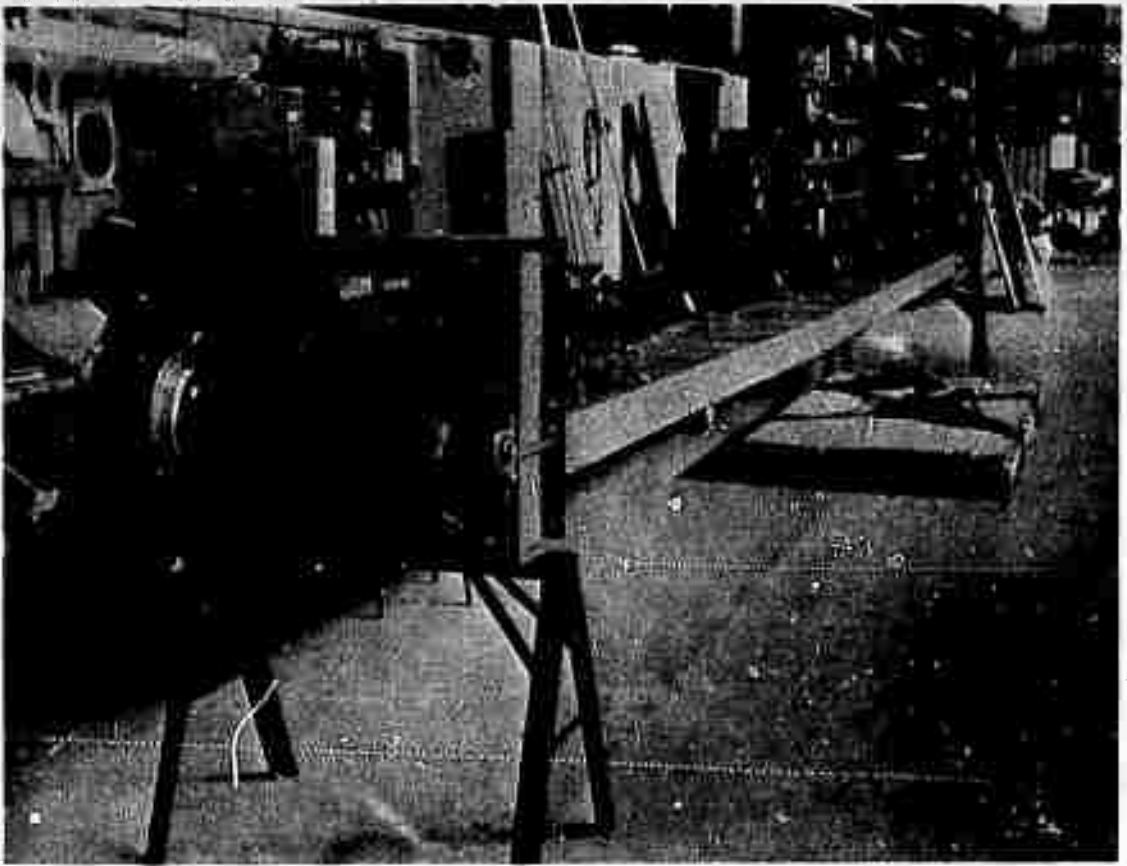

Fig. 2 Return conveyor

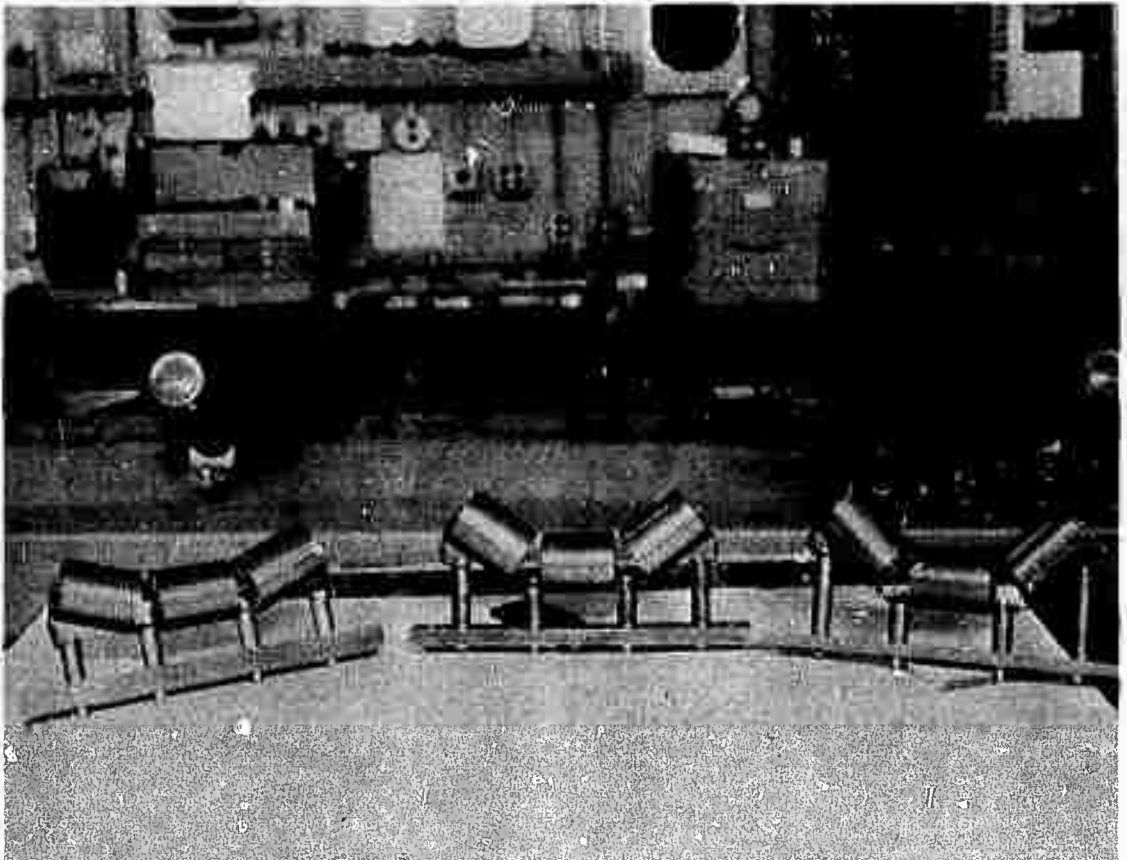

Fig. 3 Typical idler assemblies

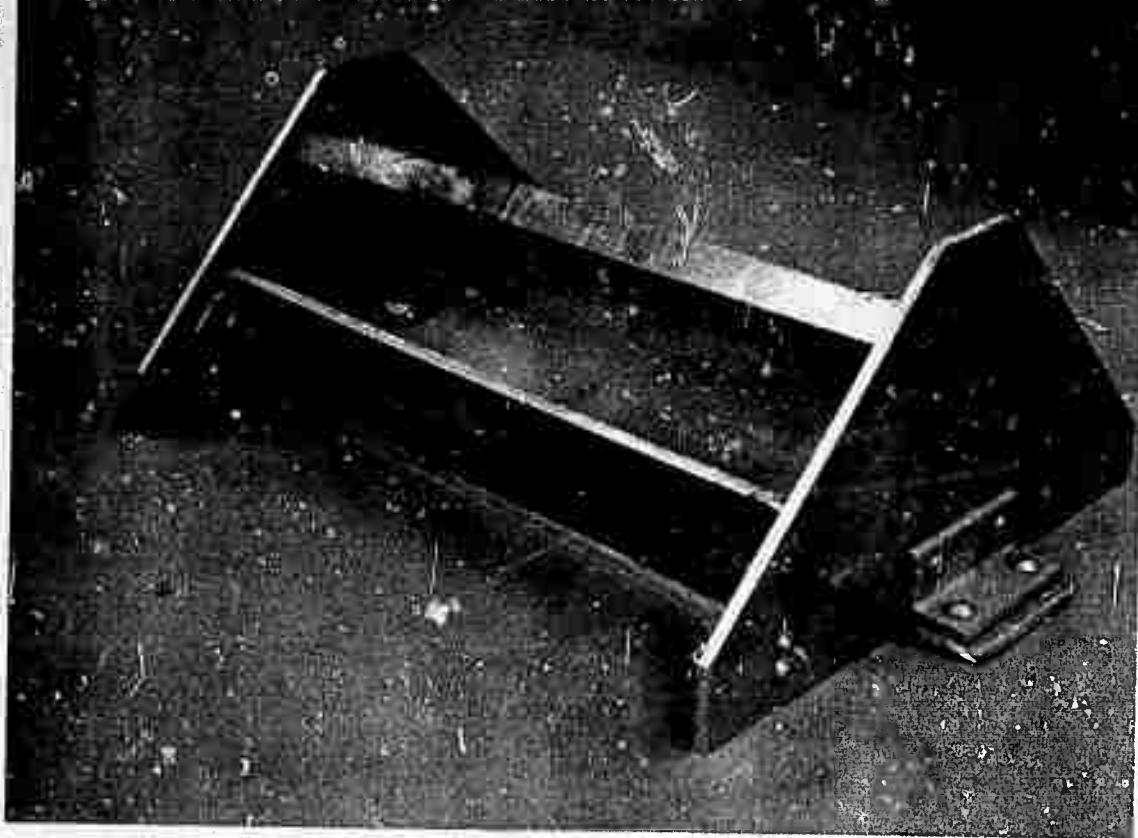

Fig. 4 Container for vertical vibration tests

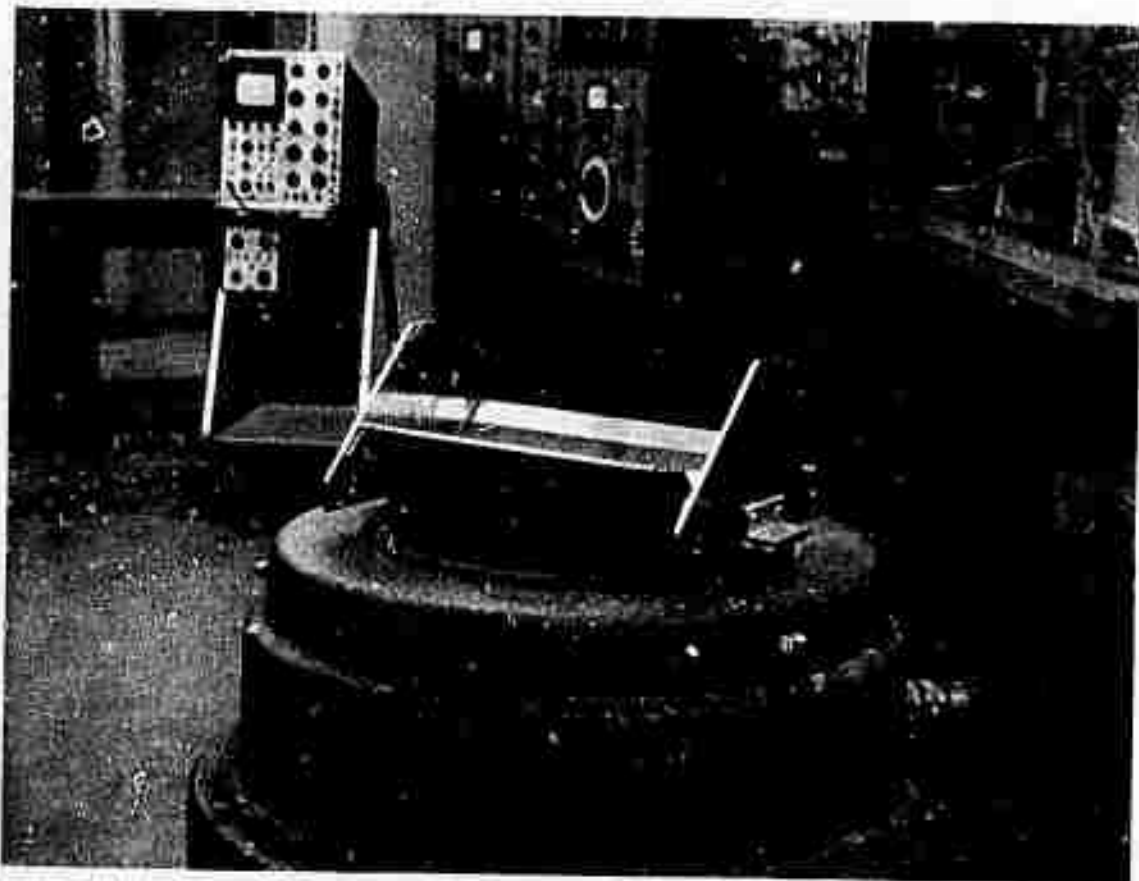
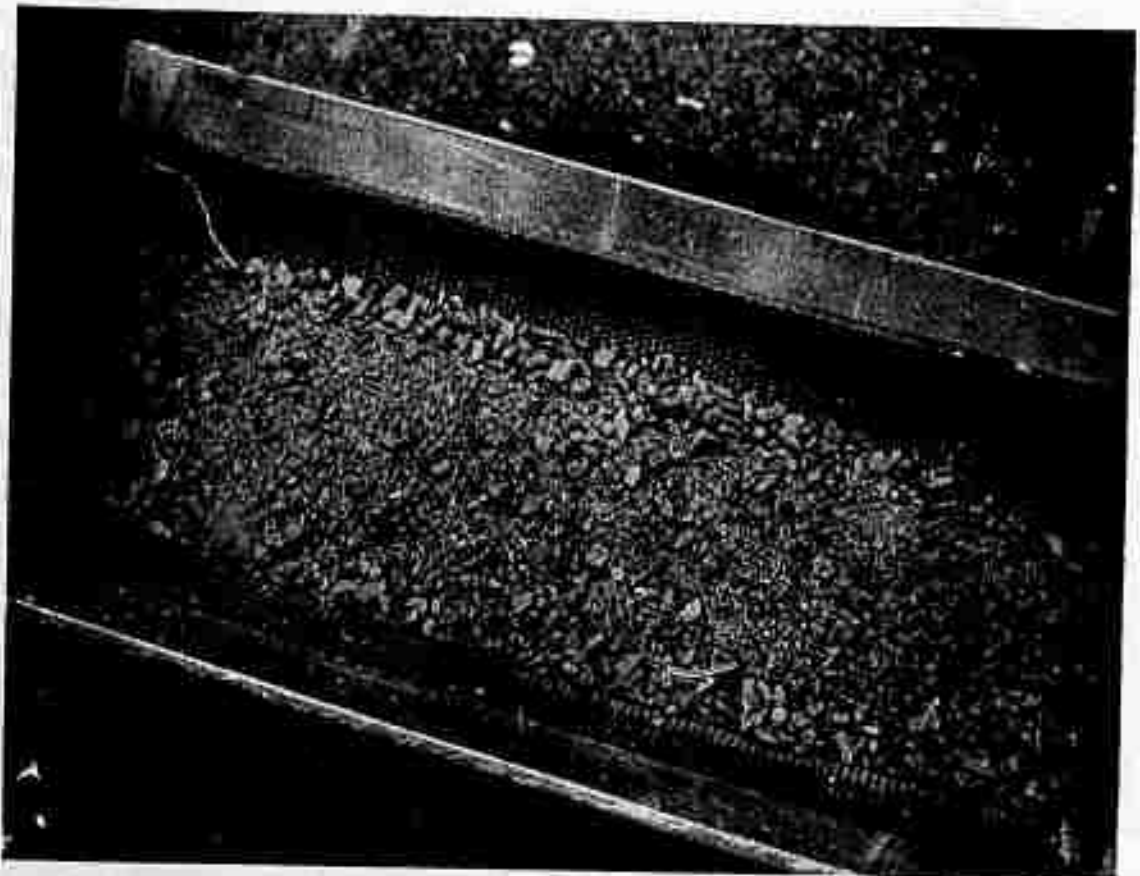

Fig. 5 Container mounted on vertical vibration machine



Fig. 6 Bulk material at angle of repose prior to testing



23

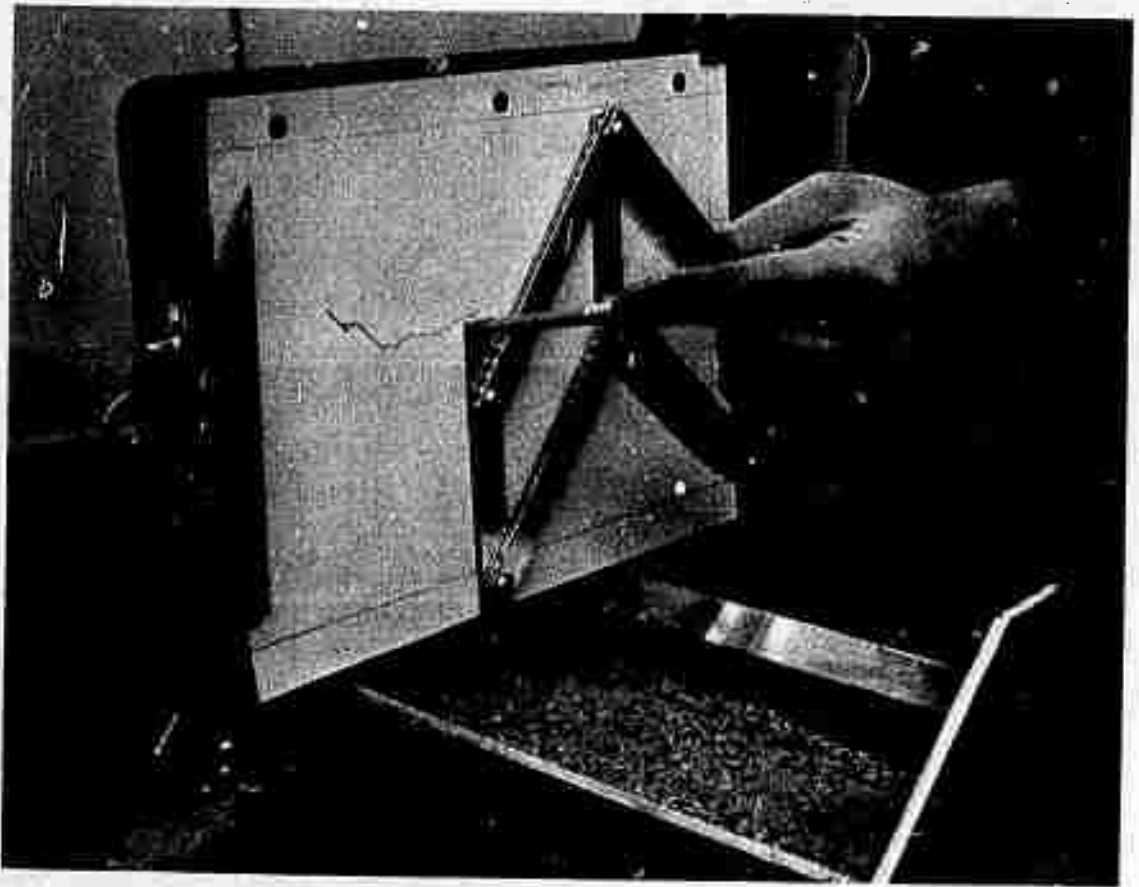

**Fig. 8 Pantograph for determining cross sectional profile of bulk material**

CROSS-SECTIONS AT 3 LOCATIONS  
ALONG TESTING DEVICE



ACCELERATION = 1.85g  
FREQUENCY = 20 CPS  
DISPLACEMENT = 0.08 in

TYPICAL CROSS-SECTION

Fig. 9

CROSS-SECTIONS AT 3 LOCATIONS  
ALONG TESTING DEVICE

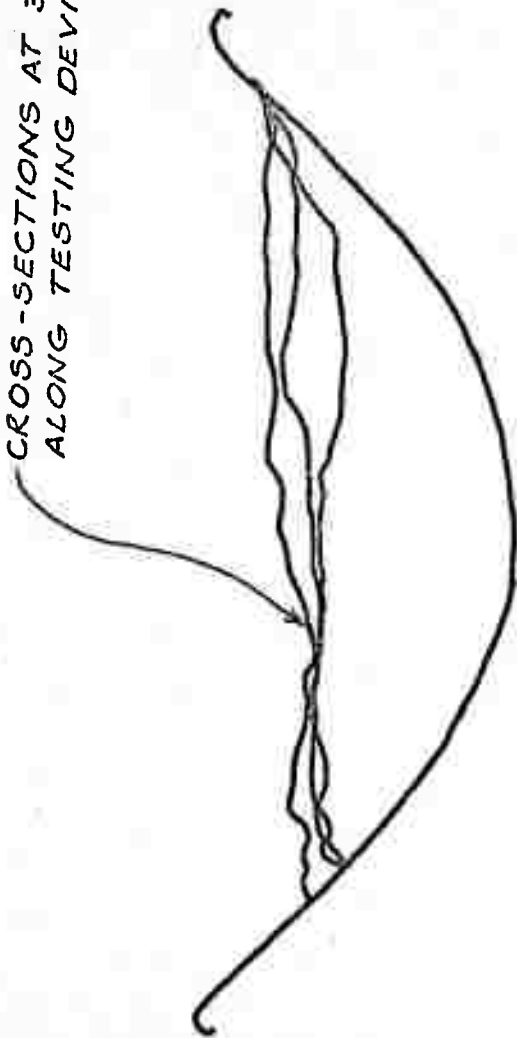

ACCELERATION = 2.5g  
FREQUENCY = 35 cps  
DISPLACEMENT = 0.04 in

25  
TYPICAL CROSS-SECTION

Fig. 10

# APPARATUS FOR CONVEYOR SIMULATION

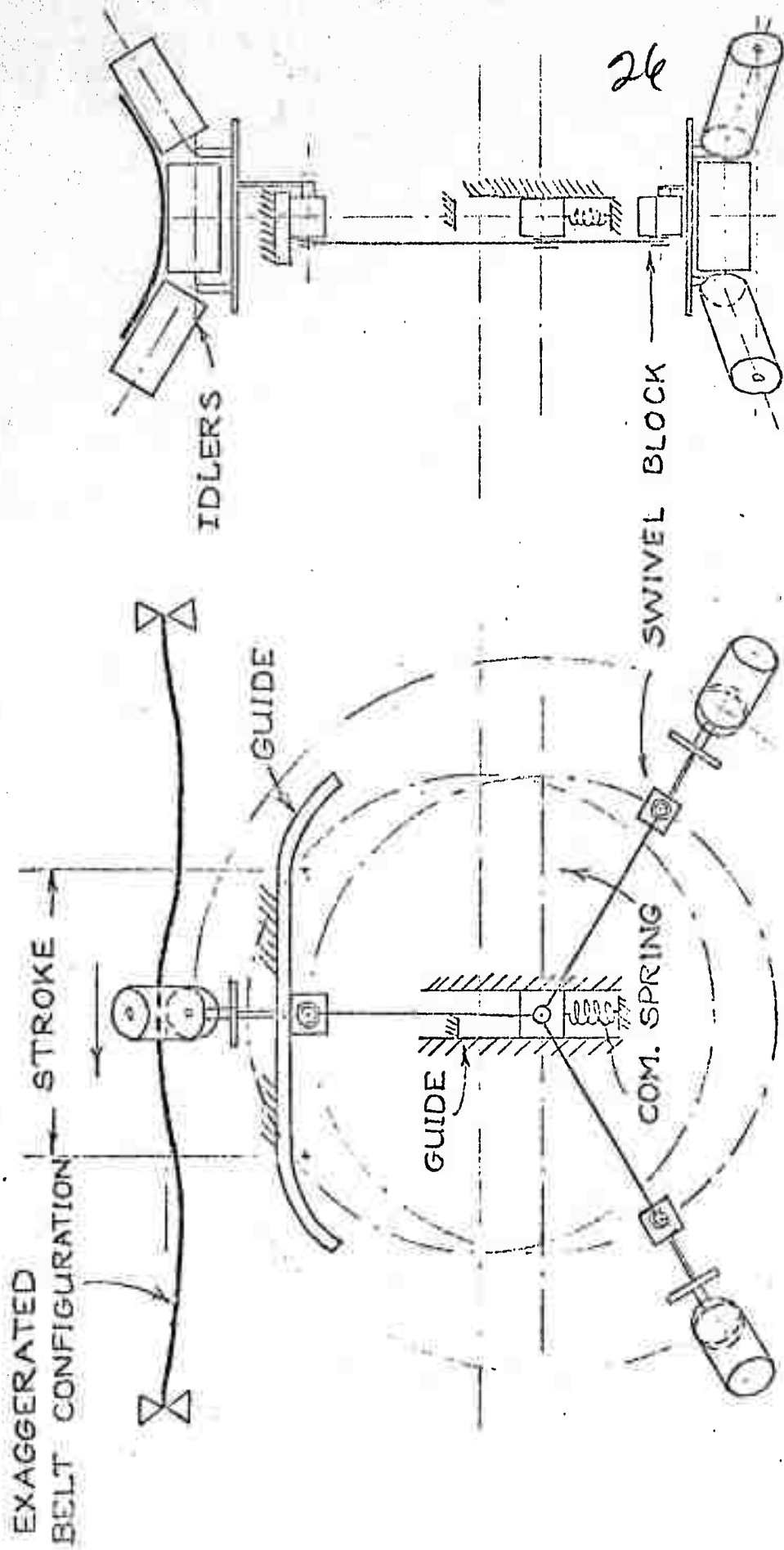
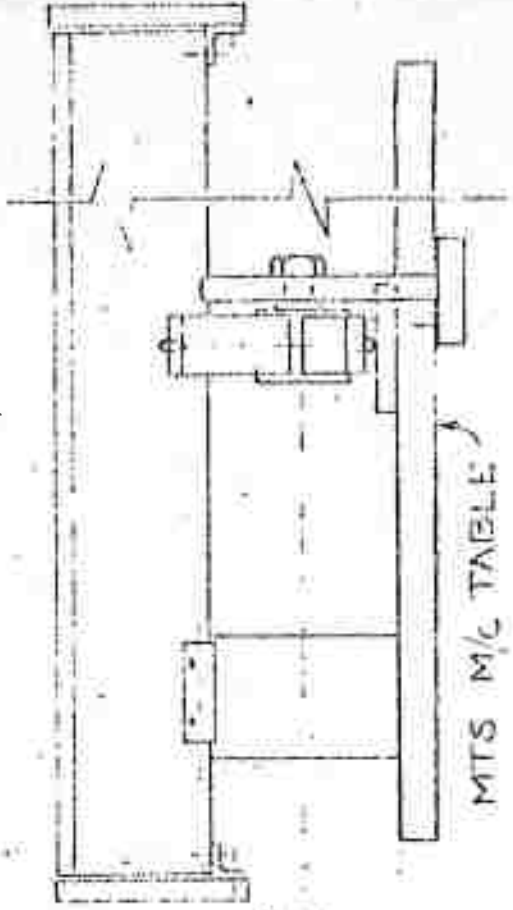
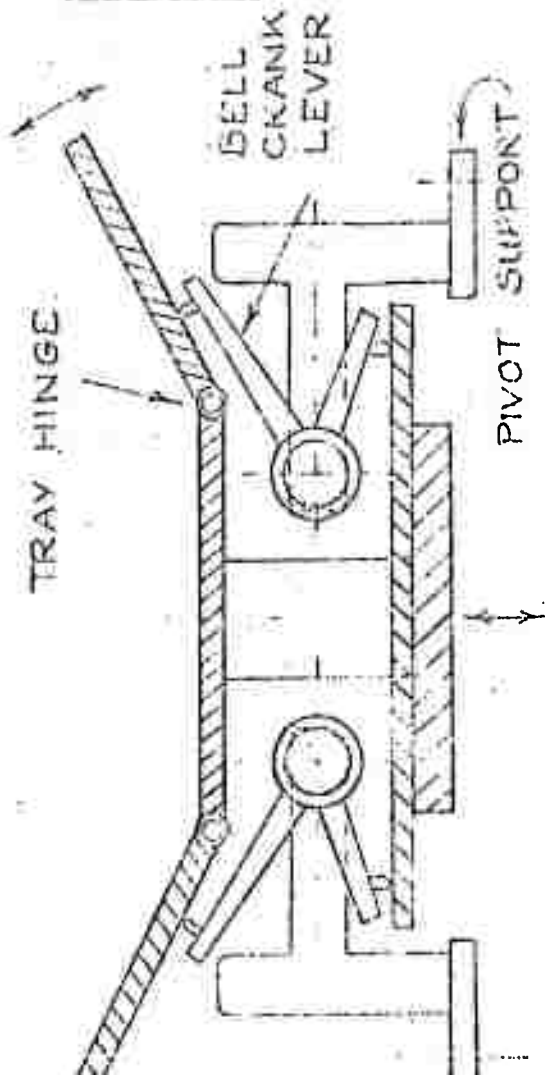

FIG. 11

# CONTAINER FOR SIMULATION OF CONVEYOR VIBRATIONS



SIDE VIEW

FRONT VIEW

27

SCALE-2:1

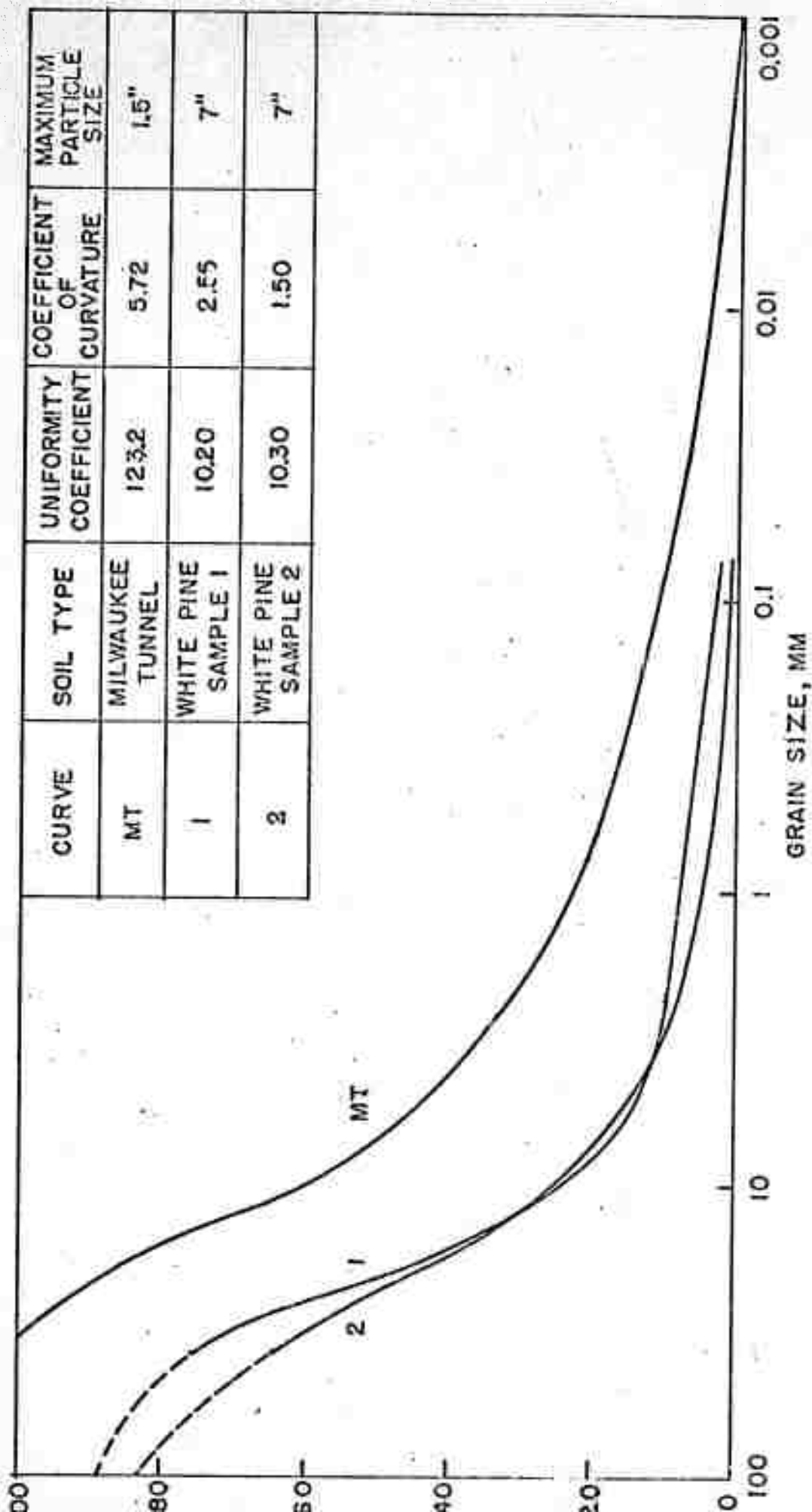

Fig. 13 Grain size distribution

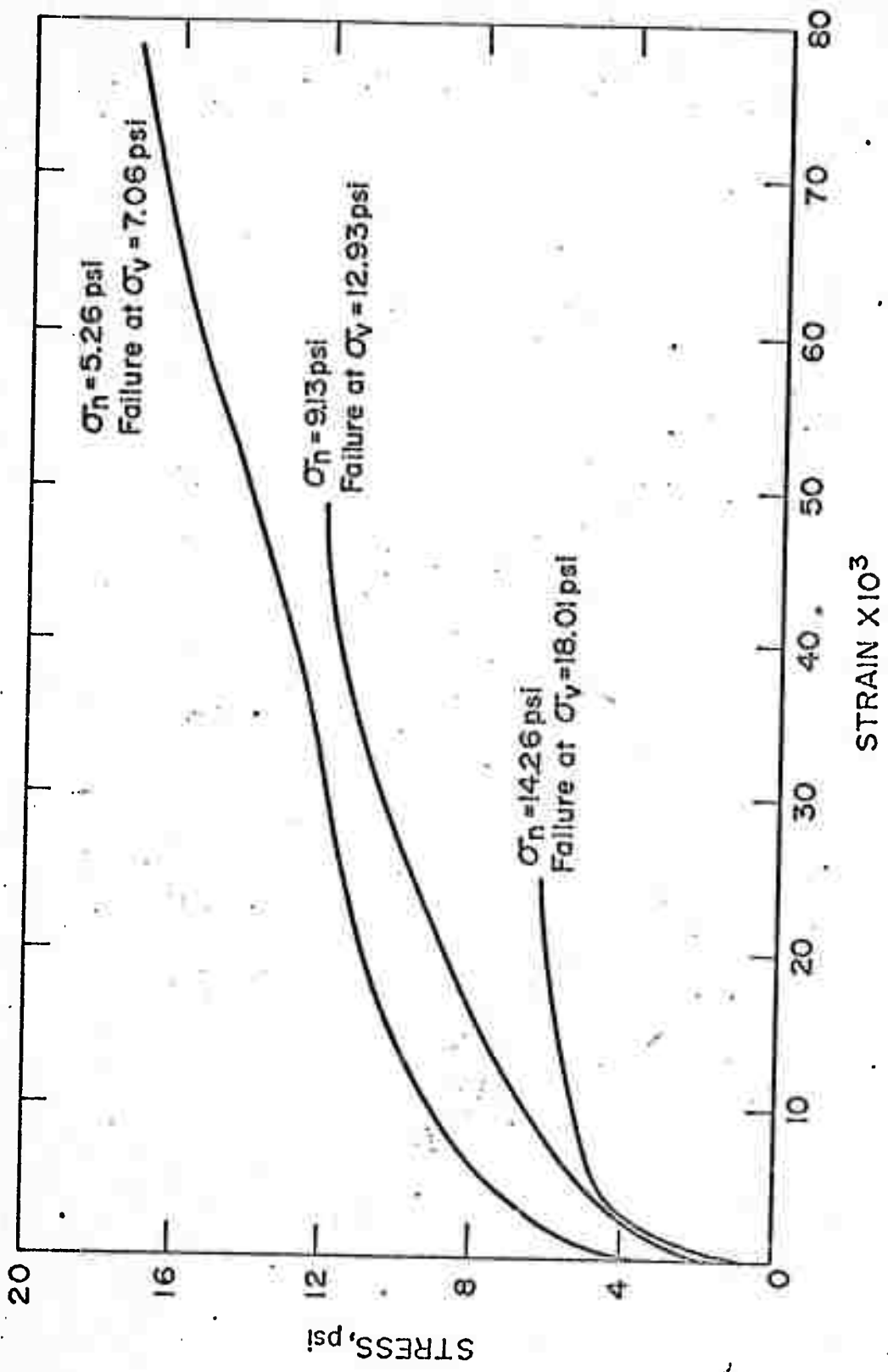

PLATE 71  
442

FIGURE 14. - Stress as a Function of Strain during Shear Test of Milwaukee Tunnel Material

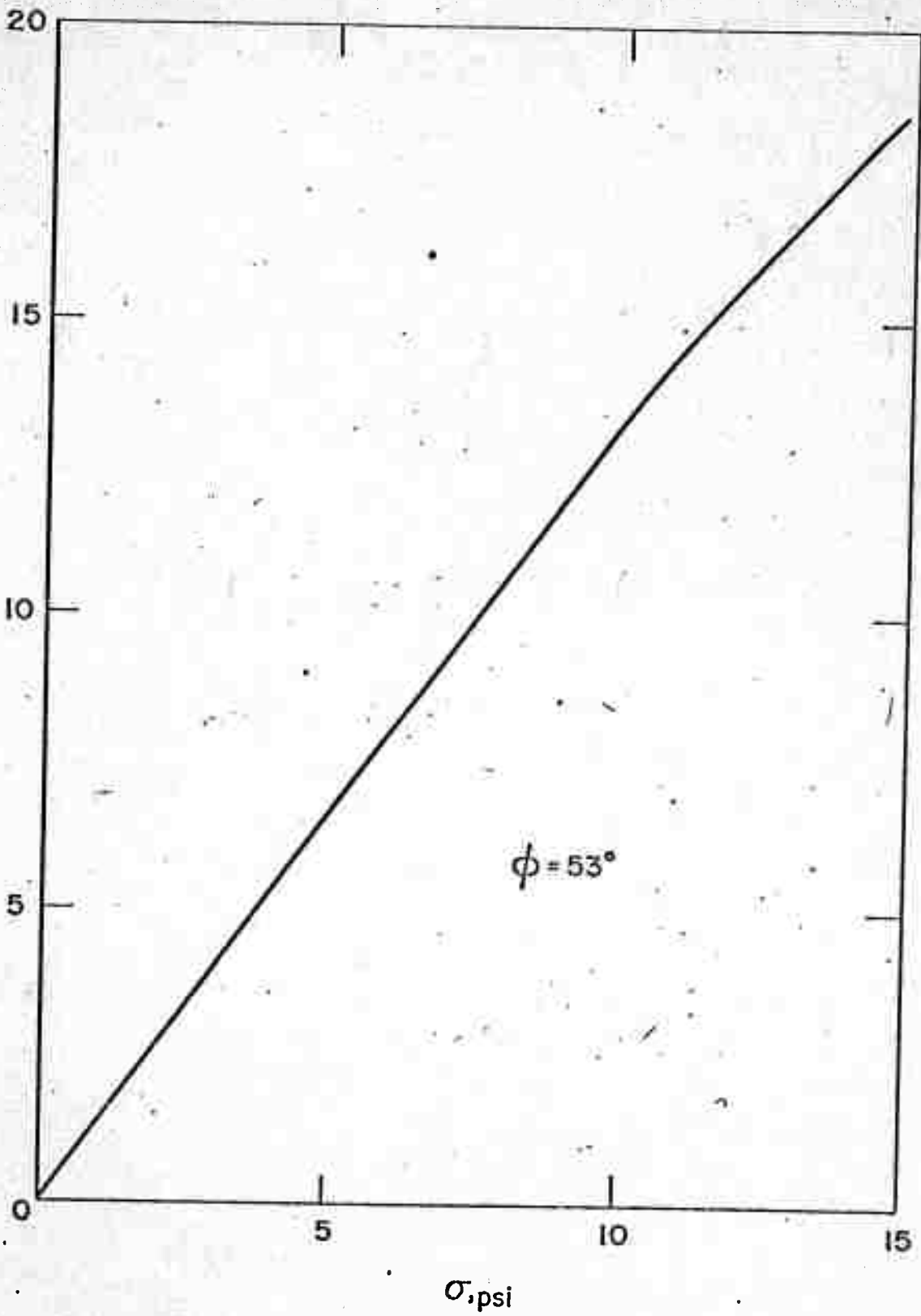

PLATE 71  
441

FIGURE 15. - Mohr Diagram for Milwaukee Tunnel Material