

cy. 2

**DEPLOYMENT AND PERFORMANCE CHARACTERISTICS
OF ATTACHED INFLATABLE DECELERATORS WITH
MECHANICALLY DEPLOYED INLETS AT
MACH NUMBERS FROM 2.6 TO 4.5**



**David E. A. Reichenau
ARO, Inc.**

June 1972

Approved for public release; distribution unlimited.

**PROPULSION WIND TUNNEL FACILITY
ARNOLD ENGINEERING DEVELOPMENT CENTER
AIR FORCE SYSTEMS COMMAND
ARNOLD AIR FORCE STATION, TENNESSEE**

NOTICES

When U. S. Government drawings specifications, or other data are used for any purpose other than a definitely related Government procurement operation, the Government thereby incurs no responsibility nor any obligation whatsoever, and the fact that the Government may have formulated, furnished, or in any way supplied the said drawings, specifications, or other data, is not to be regarded by implication or otherwise, or in any manner licensing the holder or any other person or corporation, or conveying any rights or permission to manufacture, use, or sell any patented invention that may in any way be related thereto.

Qualified users may obtain copies of this report from the Defense Documentation Center.

References to named commercial products in this report are not to be considered in any sense as an endorsement of the product by the United States Air Force or the Government.

**DEPLOYMENT AND PERFORMANCE CHARACTERISTICS
OF ATTACHED INFLATABLE DECELERATORS WITH
MECHANICALLY DEPLOYED INLETS AT
MACH NUMBERS FROM 2.6 TO 4.5**

**David E. A. Reichenau
ARO, Inc.**

Approved for public release; distribution unlimited.

FOREWORD

The work reported herein was done at the request of the National Aeronautics and Space Administration (NASA) Langley Research Center, Hampton, Virginia, under Program Element 921E.

The test results presented were obtained by ARO, Inc. (a subsidiary of Sverdrup & Parcel and Associates, Inc.), contract operator of the Arnold Engineering Development Center (AEDC), Air Force Systems Command (AFSC), Arnold Air Force Station, Tennessee, under Contract F40600-72-C-0003. The test was conducted in the Propulsion Wind Tunnel (16S) on May 10 and 11, 1971, under ARO Project No. PS1160. The manuscript was submitted for publication on June 18, 1971.

This technical report has been reviewed and is approved.

GEORGE F. GAREY
Lt Colonel, USAF
Chief Air Force Test Director, PWT
Directorate of Test

FRANK J. PASSARELLO
Colonel, USAF
Acting Director of Test

ABSTRACT

A test was conducted in the 16-ft Propulsion Wind Tunnel (16S) to determine deployment, inflation, and steady-state characteristics of attached inflatable decelerators. Deployments were made at a Mach number of 3.0 at a free-stream dynamic pressure of 120 psf. The mechanically deployed inlet system resulted in successful deployments of the five test models with rapid inflation times of approximately 0.2 sec. The attached decelerators were very stable throughout the Mach number range from 2.6 to 4.5 and at angles of attack through 10 deg.

CONTENTS

| | <u>Page</u> |
|--|-------------|
| ABSTRACT | iii |
| NOMENCLATURE | vi |
| I. INTRODUCTION | 1 |
| II. APPARATUS | |
| 2.1 Test Facility | 1 |
| 2.2 Test Article | 2 |
| 2.3 Instrumentation | 3 |
| III. PROCEDURE | 3 |
| IV. RESULTS AND DISCUSSION | |
| 4.1 Deployment Characteristics | 4 |
| 4.2 Steady-State Characteristics | 5 |
| V. CONCLUDING REMARKS | 6 |
| REFERENCES | 7 |

APPENDIX
ILLUSTRATIONSFigure

| | |
|--|----|
| 1. Location of Model in Test Section | 11 |
| 2. Inlet Deployment Spring | 12 |
| 3. Details of AID Models | 13 |
| 4. Inlet Location | 14 |
| 5. Installation of Undeployed Model in Test Section | |
| a. Front Three-Quarter View | 15 |
| b. Rear Three-Quarter View | 16 |
| 6. Photographs of Two AID Models at Various Test Conditions | |
| a. Model 1, $M_\infty = 3.0$, $q_\infty = 120$ psf | 17 |
| b. Model 4, $M_\infty = 3.0$, $q_\infty = 120$ psf | 17 |
| 7. Decelerator Deployment Characteristics at Mach Number 3.0, $q_\infty = 120$ psf | |
| a. Drag Characteristics | 18 |
| b. Internal Pressure Characteristics | 19 |
| 8. Photographs of the Deployment Sequence | |
| a. Model 1, $M_\infty = 3.0$, $q_\infty = 120$ psf | 20 |
| b. Model 4, $M_\infty = 3.0$, $q_\infty = 120$ psf | 20 |
| 9. Effect of Free-Stream Mach Number on the AID Drag Coefficient, $\alpha = 0$ | 21 |
| 10. Effect of Free-Stream Mach Number on the AID Pressure Ratio, $\alpha = 0$ | 21 |
| 11. Effect of Angle of Attack on Drag Coefficient with the AID Model | |
| Undeployed | 22 |
| 12. Effect of Angle of Attack on Drag Coefficient with the AID Model | |
| Deployed | 22 |

NOMENCLATURE

| | |
|------------|---|
| C_{D_D} | Drag coefficient with AID deployed |
| C_{D_u} | Drag coefficient with the AID undeployed |
| F_D | Measured drag force, lb |
| M_∞ | Free-stream Mach number |
| p_i | Decelerator internal pressure, psfa |
| p_t | Free-stream total pressure, psfa |
| q_∞ | Free-stream dynamic pressure, psf |
| S_{D_o} | Reference area of AID with burble fence, 19.63 sq ft, without burble fence, 16.25 sq ft |
| S_u | Reference area with AID undeployed, 5.81 sq ft |
| t | Time, sec |
| α | Model angle of attack, deg |

MODEL CONFIGURATIONS

- | | |
|---------|--|
| Model 1 | <ol style="list-style-type: none"> 1. 60-in. diameter including burble fence 2. Forward and aft inlet capture area, 4.91 sq in. each 3. Mounted on a pivotal adaptor |
| Model 2 | <ol style="list-style-type: none"> 1. 60.0-in. diameter including burble fence 2. Forward and aft inlet capture area, 4.91 sq in. each 3. Mounted on a rigid support system |
| Model 3 | <ol style="list-style-type: none"> 1. 60.0-in. diameter including burble fence 2. Forward inlet capture area, 4.91 sq in. each Aft inlet capture area, 2.56 sq in. each 3. Mounted on a pivotal adaptor |

- Model 4**
1. 54.6-in. diameter with no burble fence
 2. Forward and aft inlet capture area, 4.91 sq in. each
 3. Mounted on a pivotal adaptor
- Model 5**
1. 54.6-in. diameter with no burble fence
 2. Forward and aft inlet capture area, 4.91 sq in. each
 3. Mounted on a rigid support system

SECTION I INTRODUCTION

A series of investigations have been conducted in the Propulsion Wind Tunnel (16S) for the National Aeronautics and Space Administration to develop an Attached Inflatable Decelerator System (AID). An AID is essentially a low mass, inflatable canopy attached directly to a payload and has many potential applications in areas such as recovery of boosters and space hardware, and emergency retrieval of orbital spacecraft personnel as well as deceleration and landing devices in future planetary missions.

The first two tests were conducted in January and August of 1968 and are reported in Refs. 1 and 2. The investigations were made to determine the aerodynamic performance of the AID models and to study the deployment and inflation characteristics using a method of preinflation by evaporation of a liquid solution. The third and fourth tests, reported in Refs. 3 and 4, were conducted in May 1969 and September 1970 to obtain deployment and performance characteristics of an AID system with mechanically deployed inlets used to initiate the inflation sequence and to determine the effect of reducing the inlet capture area.

For the models investigated to date (also see Refs. 5 through 8), the canopy shape and attachment locations were representative of a single stage AID for which the deployed $C_D S$ value was sufficiently large to provide deceleration to touchdown. However, potential growth of future entry ballistic coefficients dictate drag augmentation over a wide range of Mach numbers and dynamic pressures such that a staged deceleration system is desirable. Such a system may consist of deployment of an AID at Mach number 4 for deceleration to Mach number 1.5 where the AID may then be detached and a large subsonic parachute deployed. The potential gain in payload with such a two-stage system is illustrated in Refs. 8 and 9. The geometry of an AID for a two-stage system differs considerably from that of the single-stage decelerator previously tested. Thus, the workability of the two-stage AID needs to be demonstrated.

The purpose, therefore, for testing the first-stage AID models was to demonstrate the deployment and aerodynamic performance at supersonic speeds.

SECTION II APPARATUS

2.1 TEST FACILITY

Tunnel 16S is a closed-circuit, continuous flow wind tunnel that presently can be operated at Mach numbers from 1.50 to 4.75. The tunnel can be operated over a stagnation pressure range from 200 to approximately 2300 psfa. The test section stagnation temperature can be controlled through a range from 100 to 620°F. The tunnel specific humidity is controlled by removing tunnel air and supplying conditioned make-up air from an atmospheric dryer.

Details of the test section, showing the model location and sting support arrangement, are presented in Fig. 1 in the Appendix. A more extensive description of the tunnel and its operating characteristics is contained in Ref. 10.

2.2 TEST ARTICLE

The five similar test models consisted of 140-deg conical aeroshells with a base diameter of 32 in. and an attached inflatable textile canopy that extended to a diameter of 60 in. including a five-percent burble fence on Models 1, 2, and 3 and a diameter of 54.6 in. without a burble fence on Models 4 and 5. Each of the models had four mechanically deployed inlets (see Fig. 2) attached to the base of the aeroshell at 90-deg intervals. In addition, the models had four conventional ram-air inlets located just forward of the decelerator maximum diameter and rotated 45 deg with respect to the forward inlets. Major model details and dimensions are shown in Fig. 3, and a sketch showing the inlet locations is presented in Fig. 4. Wind tunnel installation photographs of the aeroshell model with the decelerator stowed are shown in Fig. 5. Photographs of Models 1 and 4 with the decelerator deployed at $M_{\infty} = 3.0$ are shown in Fig. 6.

The conical aeroshell was made of aluminum alloy sheet, spun formed into final shape after an intermediate stabilizing treatment. Two different transitional support systems were used between the sting-mounted internal balance and the aeroshell. A pivotal balance adaptor made of low carbon steel serves as the transition support for Models 1, 2, and 3 and a rigid close-fitting, low carbon, steel tube served as the transitional support for Models 4 and 5. The pivotal adaptor incorporates a spherical bearing which permits the aeroshell to move ± 20 deg of angular displacement in pitch and yaw. A hydraulic cylinder moves a centering pin which permits the aeroshell this freedom to move. The pivotal adaptor was furnished with anti-rotational pins to keep the model from rotating resulting in the twisting of instrumentation wires.

The AID unit was constructed of Nomex[®] cloth and was coated with Viton[®] (a high temperature rubber). The inflatable afterbody was designed for minimum weight by applying the concept of isotensoid design (Ref. 11). The decelerator was secured to the aeroshell by clamping the canopy end bands. The outer attachment is made to the aeroshell profile and the inner attachment to the ring support with aluminum clamping rings as shown in Fig. 3. The decelerator was restrained in its package configuration in the aeroshell storage compartment by a series of loops assembled together to form a "daisy chain" hoop around the ring support as shown in Fig. 5b. Six pyrotechnic cutters were provided to sever the chain restraining cord so as to completely release the chain restraint on a given electrical signal. Deployment of the AID from the base of the aeroshell was then accomplished by releasing the mechanically deployed inlets which were held in the stowed position (see Fig. 5b) by a restraining cord looped around the ring support. Release of the inlets was accomplished by severing the restraining cord with two pyrotechnic cutters approximately 0.5 sec after the release of the daisy chain.

2.3 INSTRUMENTATION

An internally mounted, six-component, strain-gage balance was used to measure the model forces to within ± 10 lb for the range of loads measured during these tests. The decelerator internal pressure was measured with a model-mounted, five-psid transducer. Six motion-picture cameras and two television cameras, looking through window ports in the test section walls, were used to document and monitor the test.

Outputs from the balance and pressure transducers were digitized and code punched on paper tape for on-line data reduction. These outputs were also continuously recorded on direct-writing and film pack oscillographs for monitoring model dynamics. The balance outputs were also recorded on magnetic tape by a high-speed digital recording system at a sampling rate of 500 per second for off-line data reduction.

SECTION III PROCEDURE

The AID unit was carefully packed into the aeroshell storage compartment before wind tunnel test operation was initiated. Once the prescribed test conditions were established, steady-state data were obtained for the undeployed condition. A countdown procedure was used to sequence data acquisition during the AID deployment. The deployment procedure consisted of activating the recording oscillographs, the high-speed digital recording system, and the test section cameras, followed by energizing an automatic sequencer system which initiated the signal to the pyrotechnic cutters, restraining the daisy chain 0.5 sec before severing the mechanically deployed inlet restraining cord. Upon completion of the AID deployment sequence, steady-state loads were calculated by averaging the analog signals from the balance over a 1-sec interval.

SECTION IV RESULTS AND DISCUSSION

Deployment, inflation, and steady-state data were obtained for five inflatable decelerator models attached to the base of an aeroshell entry capsule. All five models were deployed at a free-stream Mach number of 3.0 with a dynamic pressure of 120 psf. After the deployment sequence was completed, the decelerator performance was investigated at various free-stream Mach numbers and angles of attack. A summary of the test conditions is presented below.

| <u>Model Number</u> | <u>Deployed Condition</u> | <u>M_∞</u> | <u>q_∞</u> | <u>α, deg</u> | <u>Reference Area</u> |
|---------------------|---------------------------|------------------------------|------------------------------|---------------------------------|-----------------------|
| 1 | Undeployed | 3.00 | 120 | 0 to 10 | 19.63 ↓ |
| | Deployed | 3.00 | 120 | 0 to 10 | |
| | Deployed | 3.50 | 120 | 0 to 10 | |
| | Deployed | 4.00 | 108 | 0 to 10 | |
| | Deployed | 4.50 | 71 | 0 to 10 | |

| <u>Model Number</u> | <u>Deployed Condition</u> | <u>M_∞</u> | <u>q_∞</u> | <u>α, deg</u> | <u>Reference Area</u> |
|---------------------|---------------------------|----------------------|----------------------|---------------|------------------------------|
| 2 | Undeployed | 3.00 | 120 | 0 to 10 | 19.63 ↓ 16.25 ↓ |
| | Deployed | 3.00 | 120 | 0 to 10 | |
| 3 | Undeployed | 3.00 | 120 | 0 to 10 | |
| | Deployed | 3.00 | 120 | 0 to 10 | |
| | Deployed | 2.60 | 120 | 0 | |
| 4 | Undeployed | 3.00 | 120 | 0 to 10 | |
| | Deployed | 3.00 | 120 | 0 to 10 | |
| | Deployed | 3.70 | 120 | 0 to 10 | |
| 5 | Undeployed | 3.00 | 120 | 0 to 10 | |
| | Deployed | 3.00 | 120 | 0 to 10 | |
| | Deployed | 3.70 | 120 | 0 to 10 | |

Data were also obtained for Models 1, 3, 4, and 5 in Mach number increments of 0.10 at $\alpha = 0$.

4.1 DEPLOYMENT CHARACTERISTICS

One of the primary objectives of this test was to determine the deployment characteristics of the first-stage AID models at supersonic speeds with a mechanically deployed inlet system for the initiation of the inflation sequence.

The deployment-time histories of the AID drag load and internal pressure rise are presented in Figs. 7a and b, respectively, for the five models deployed at a Mach number of 3.0 and a dynamic pressure of 120 psf. Time zero represents the time when the mechanically deployed inlet cutters were activated. The models (Models 1, 2, and 3 with a burble fence and Models 4 and 5 without a burble fence) required approximately 0.2 sec to reach the maximum level of drag load and 0.3 sec to reach the maximum level of internal pressure. Model 1 was mounted on the pivotal adaptor and deployed at $\alpha = 0$ deg with the model free to pivot ± 20 deg in pitch and/or yaw. Although no pivotal motion was observed during deployment, it was noted throughout the test that the pivotal models (Models 1, 3, and 4) were binding when the aerodynamic load was applied to the models, and, therefore, the pivotal motions of the model during deployment are questionable.

A comparison of the deployment-time history is made in Figs. 7a and b with previously tested AID models using a liquid vaporization system and a mechanically deployed inlet system for inflation initiation (Refs. 1 and 3, respectively). The drag rise for Model 1 is similar to the AID model using the liquid vaporization technique and required approximately the same time to reach full inflation. It should be noted, however, that the AID deployment with the liquid vaporization system had a sharp pressure rise

immediately after initiation of deployment resulting in a decelerator over-pressure. This was the first deployment made with the liquid vaporization system, and all subsequent deployments were made with a 50-percent reduction in the amount of liquid to reduce the initial pressure rise. Comparison of the Model 1 deployment with a previously tested AID model using a mechanically deployed inlet system indicated that the Model 1 deployment took approximately 0.2 sec less time to reach full inflation at the same test conditions. It should be noted that the drag force of the larger, blunter aeroshell of this test was approximately twice as high as the drag force of the aeroshells in Refs. 1 and 3.

Model 2, constructed identically to Model 1, was mounted on the rigid support system and deployed at an angle of attack of 5 deg. Comparison of this deployment with Model 1 shows very similar trends and inflation times, indicating little effect of angle of attack up to 5 deg on the decelerator deployment characteristics.

Model 3 was constructed identically to Models 1 and 2 with the exception of a smaller aft inlet capture area (2.56 sq in. compared to 4.91 sq in.) The decrease in capture area of the aft inlets resulted in a slight increase in the time required to reach full inflation and a decrease in the opening load dynamics.

Models 4 and 5, constructed without a burble fence, required less time to reach full inflation than Models 1, 2, and 3 with the burble fence. The decrease in inflation time was expected as a result of the reduction in the internal volume of Models 4 and 5. Model 4, mounted on the pivotal adaptor, and Model 5, mounted on the rigid support system, were deployed at 0- and 10-deg angles of attack, respectively. Both models exhibited more opening load dynamics than the models with the burble fence, with Model 5 exhibiting the higher dynamics. Photographs showing various stages of the deployments of Model 1 and Model 4 are presented in Fig. 8.

4.2 STEADY-STATE CHARACTERISTICS

Steady-state drag data were obtained for the AID model at free-stream Mach numbers from 2.60 to 4.50 and at angles of attack from 0 to 10 deg. The drag coefficients presented for the undeployed configuration are based on the aeroshell reference area, S_u , and the drag coefficients of the deployed configurations are based on the AID reference area, S_{D_0} . Photographic coverage and oscillograph traces obtained during the tests of all five models indicated that, for all test conditions including angles of attack through 10 deg, the fully inflated decelerator was very stable with no oscillating forces or moments.

The decelerator drag coefficient and corresponding pressure ratio (p_i/p_{t_∞}) are presented in Figs. 9 and 10, respectively, for the five models investigated. Steady-state drag data (Fig. 9) were obtained for Model 1 at Mach numbers from 3.0 to 4.5 and Model 3 at Mach numbers from 2.6 to 3.0. Comparison of these data with previous test data of an AID model shows close agreement, although the previously tested AID model (Ref. 2) consisted of 120-deg aeroshells whereas the model investigated during this test consisted of 140-deg aeroshells. The data obtained with Model 2 at a free-stream Mach number of 3.0 also shows close agreement with the previous test data. No further data were obtained

with Model 2 to conserve time to test additional AID models. All three models with the burble fence show close agreement in both drag and internal pressure ratio at Mach number 3.0.

Steady-state drag data (Fig. 9) were obtained for Models 4 and 5 at Mach numbers from 3.0 to 3.7. These models without the burble fence exhibited a seven-percent increase in drag coefficient when compared to Models 1, 2, or 3 with a burble fence. The reference diameters of Models 1, 2, and 3 are based on the diameter of the AID including the burble fence, which is not as effective a drag-producing area as a model with the same diameter without a burble fence. Similar results have been observed during tests of Ballutes[®] with and without a burble fence (Ref. 12). The decelerator internal pressure ratios shown in Fig. 10 were in good agreement with the designed pressure ratio required for full inflation of the AID models.

The drag coefficients of the aeroshell without and with the decelerator deployed are presented in Fig. 11 and 12, respectively, for angles of attack from 0 to 10 deg. An increase in angle of attack produced a slight decrease in the drag coefficient of both the undeployed and deployed configurations. However, the decrease in deployed drag coefficient (Fig. 12) with angle of attack was less than two percent at all test Mach numbers showing good decelerator performance at angles of attack through 10 deg. Comparison of these data with results from previous tests show an increase in drag coefficient for both the undeployed and deployed configurations. The increase in drag coefficient is primarily due to the blunter aeroshell on the models investigated during this test.

SECTION IV CONCLUDING REMARKS

Tests were conducted to investigate deployment, inflation, and steady-state characteristics of an AID system with mechanically deployed inlets. Deployments were made at a Mach number of 3.0 and at a free-stream dynamic pressure of 120 psf. The following observations are a result of these tests:

1. Inflation of the AID models with a mechanically deployed inlet system resulted in successful deployments of five models with an inflation time of approximately 0.2 sec.
2. Deployment and inflation characteristics of the models with mechanically deployed inlets compared favorably with those using a liquid vaporization inflation system in previous tests.
3. All five AID models remained fully inflated and exhibited excellent stability characteristics at all test Mach numbers and angles of attack through 10 deg.
4. Decreasing the total capture area of the rear inlets from 19.64 sq in. to 10.24 sq in. resulted in essentially no change in the AID deployment and steady-state characteristics.

5. The steady-state drag coefficients of the AID models without the burble fence were higher than those obtained on the models with the burble fence.
6. The steady-state drag coefficients of the deployed decelerators decreased less than two percent as angle of attack was increased to 10 deg.

REFERENCES

1. Reichenau, D. E. A. "Investigation of an Attached Inflatable Decelerator System for Drag Augmentation of the Voyager Entry Capsule at Supersonic Speeds." AEDC-TR-68-71 (AD829831), April 1968.
2. Baker, D. C. "Investigation of an Inflatable Decelerator Attached to a 120-deg Conical Entry Capsule at Mach Numbers from 2.55 to 4.40." AEDC-TR-68-227 (AD841099), October 1968.
3. Baker, D. C. "Investigation of an Attached Inflatable Decelerator with Mechanically Deployed Inlets at Mach Numbers from 2.25 to 4.75." AEDC-TR-69-132 (AD854437), June 1969.
4. Baker, D. C. "Performance Evaluation of Attached Inflatable Decelerators with Mechanically Deployed Inlets at Mach Numbers from 2.6 to 4.4." AEDC-TR-70-254 (AD876659), November 1970.
5. Mikulas, M. M., Jr. and Bohon, H. L. "Development Status of Attached Inflatable Decelerators." AIAA Journal of Spacecraft and Rockets, Vol. 6, No. 6, June 1969.
6. Development of Attached Inflatable Decelerators for Supersonic Application. NASA CR-66613, May 1968.
7. Bohon, Herman L. and Miserentino, Robert. "Deployment and Performance Characteristics of 5-Foot Diameter (1.5 m) Attached Inflatable Decelerators from Mach Number 2.2 to 4.4." NASA TN D-5840, August 1970.
8. Bohon, H. L. and Miserentino, R. "Attached Inflatable Decelerator Performance Evaluation and Mission-Application Study." AIAA Third Aerodynamic Deceleration System Conference, Wright-Patterson AFB, Ohio, September 14-16, 1970.
9. Gillis, Clarence L. "Aerodynamic Deceleration System for Missions." Presented at the AIAA Fifth Annual Meeting, Philadelphia, Pennsylvania, October 1968.
10. Test Facilities Handbook (Eighth Edition). "Propulsion Wind Tunnel Facility, Vol. 5." Arnold Engineering Development Center, December 1969 (AD863646).

11. Houtz, N. E. "Optimization of Inflatable Devices by Isotensoid Design." AIAA Paper No. 64-437, First Annual AIAA Meeting and Technical Display, Washington, D. C., June 29 through July 2, 1964.
12. MacLanahan, D. A. "An Investigation of Various Types of Decelerators at Mach Number 2.8." AEDC-TR-66-136 (AD485279), July 1966.

**APPENDIX
ILLUSTRATIONS**

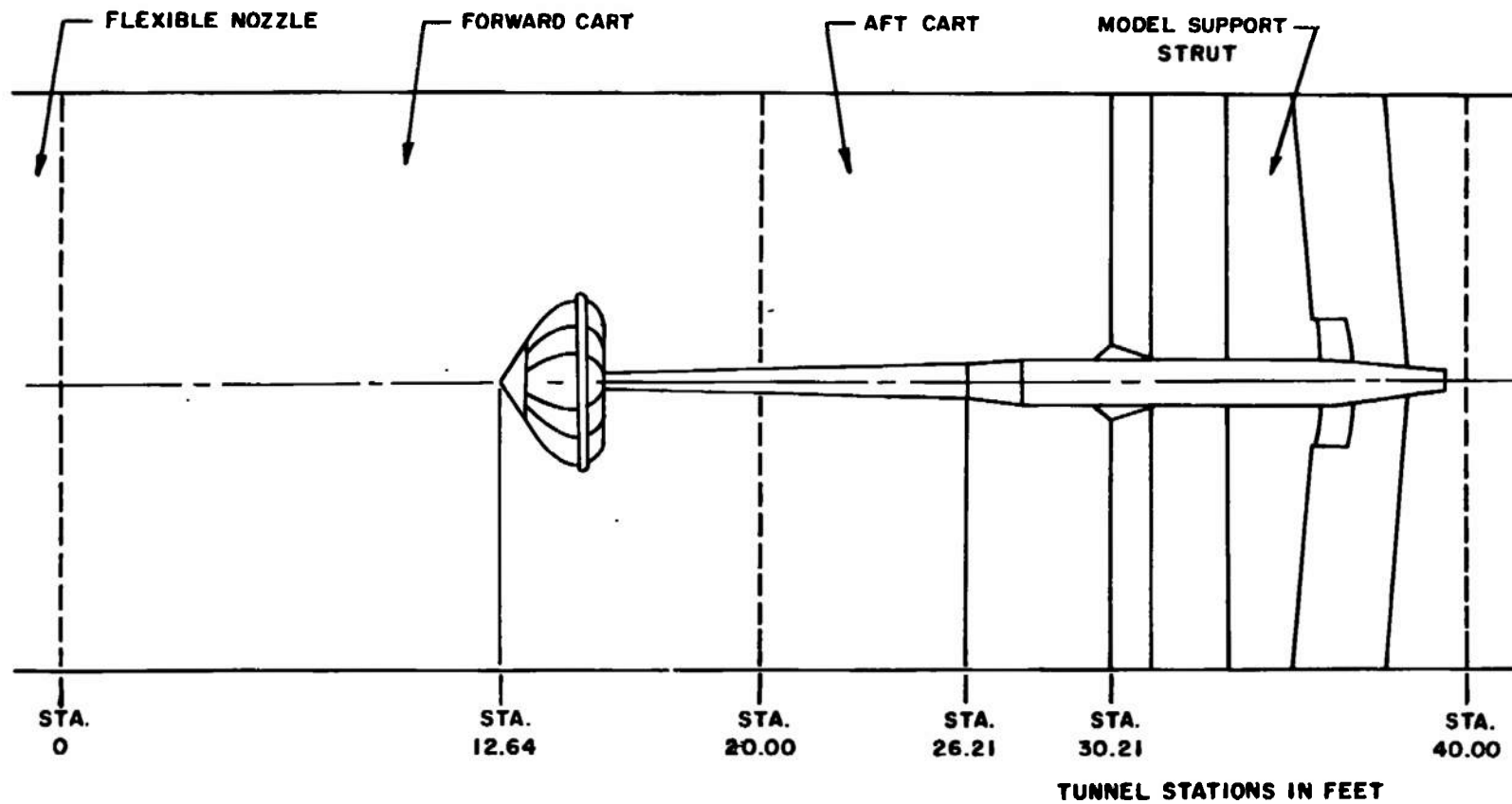

Fig. 1 Location of Model in Test Section

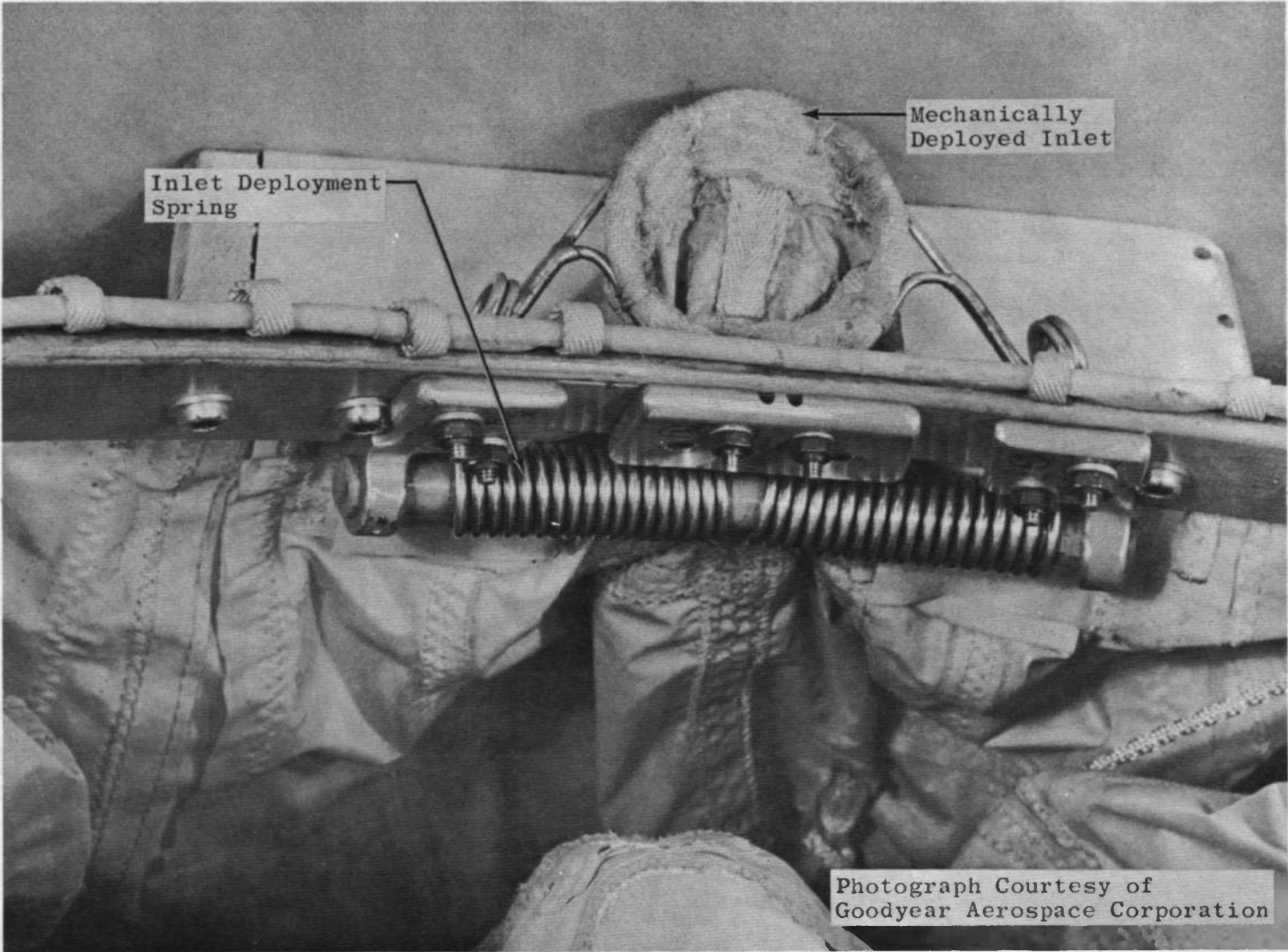
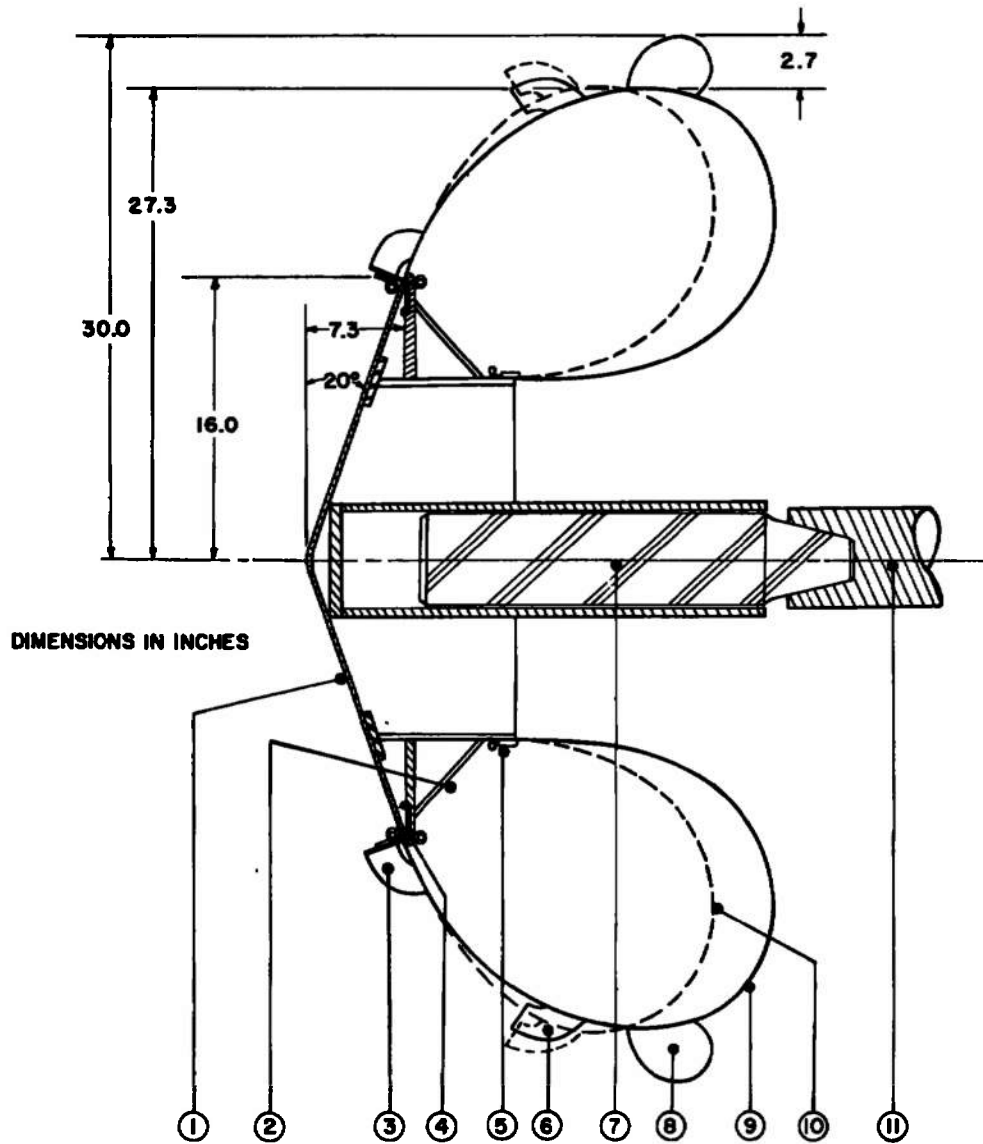

Fig. 2 Inlet Deployment Spring

BOM
M98
204-2



DIMENSIONS IN INCHES

- 1. AEROSHELL
- 2. DECELERATOR STOWAGE COMPARTMENT
- 3. FORWARD INLETS, ROTATED 45° (TYP. 4 PLACES)
- 4. DECELERATOR CLAMP (OUTER)
- 5. DECELERATOR CLAMP (INNER)
- 6. AFT INLETS (TYP. 4 PLACES)
- 7. SIX-COMPONENT BALANCE
- 8. BURBLE FENCE
- 9. INFLATABLE DECELERATOR, WITH BURBLE FENCE
- 10. INFLATABLE DECELERATOR, WITHOUT BURBLE FENCE
- 11. STING SUPPORT

Fig. 3 Details of AID Models

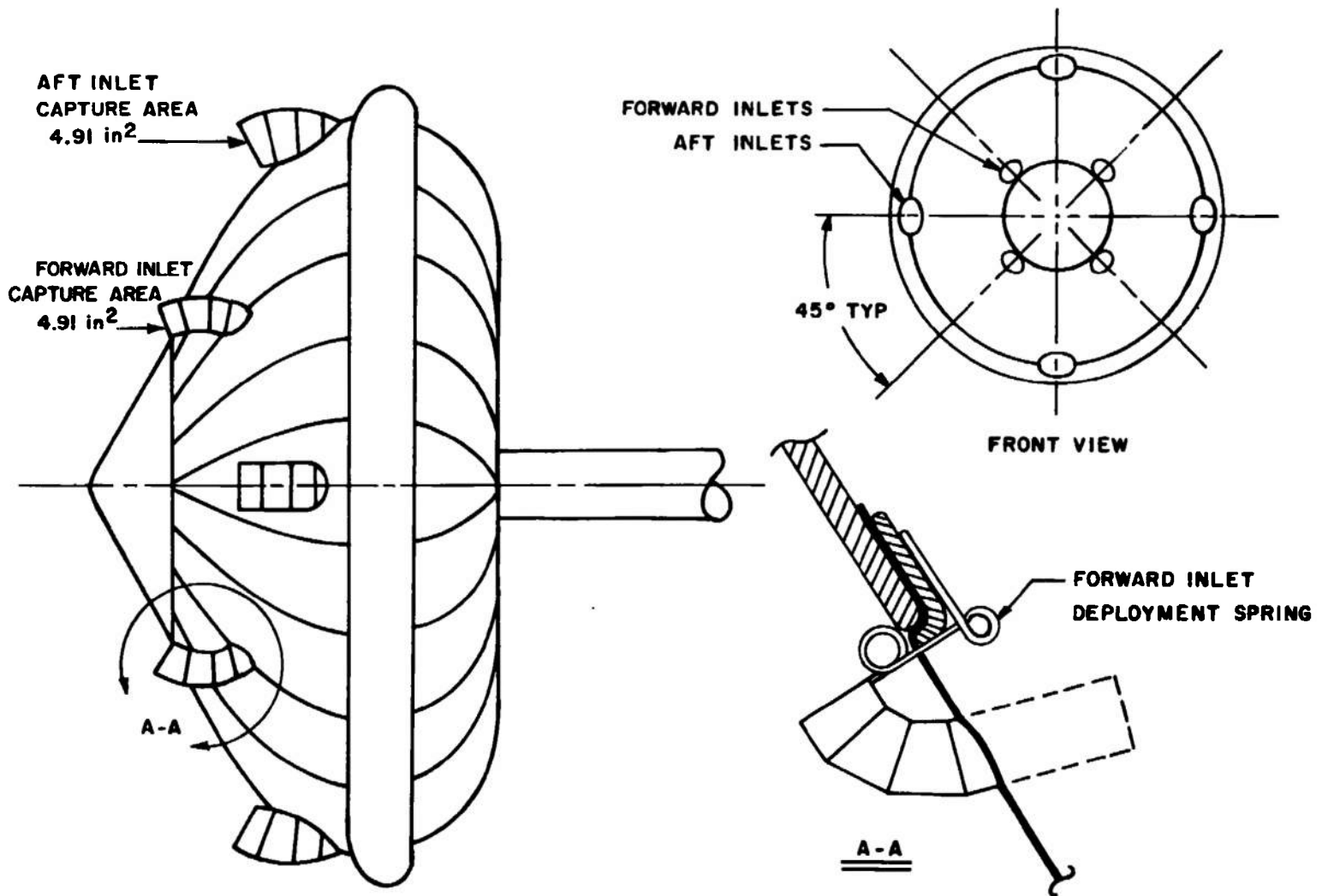

NOTE: AFT INLETS CAPTURE AREA ON MODEL 3
2.56 in²

Fig. 4 Inlet Location

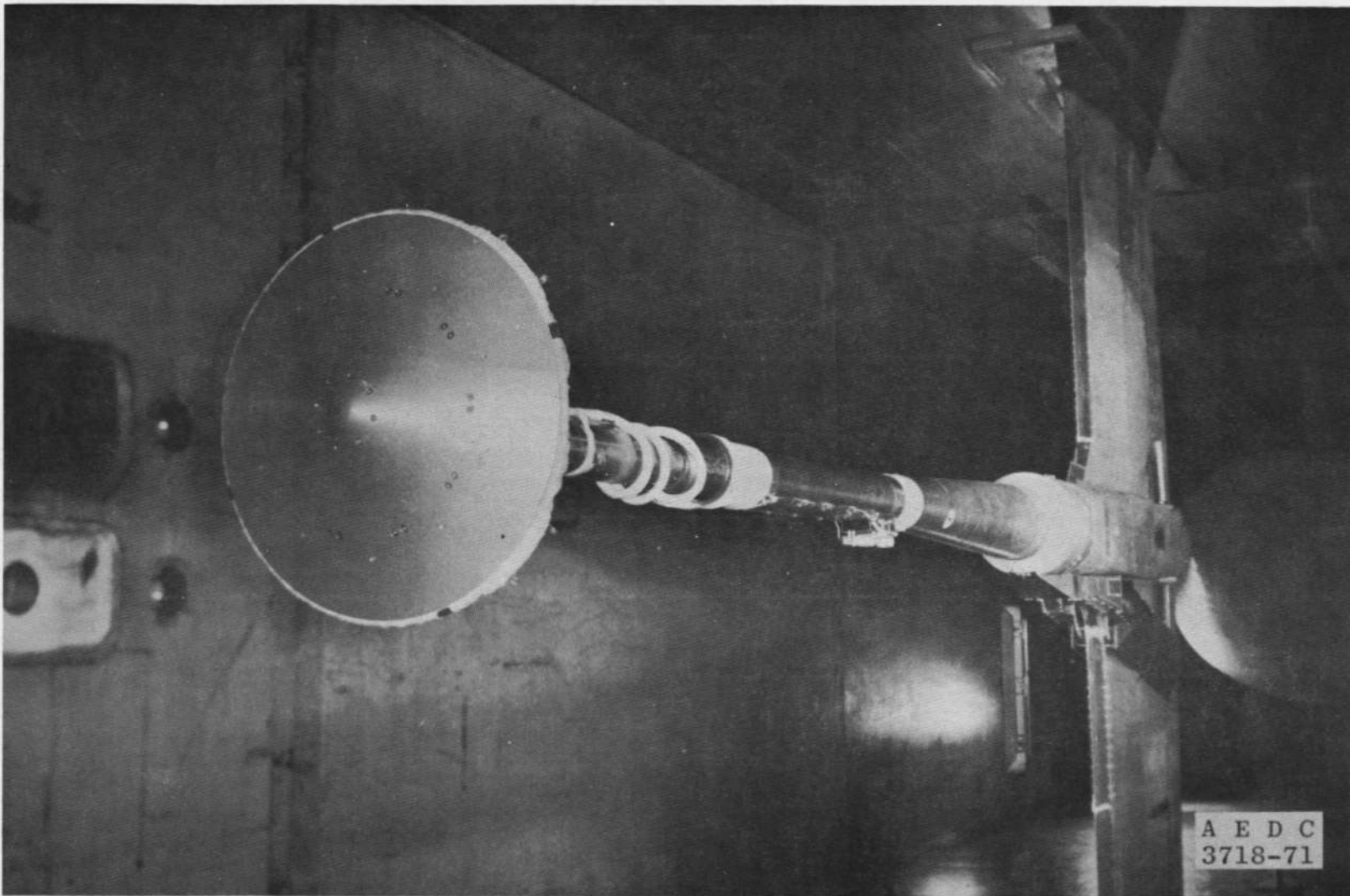

a. Front Three-Quarter View
Fig. 5 Installation of Undeployed Model in Test Section

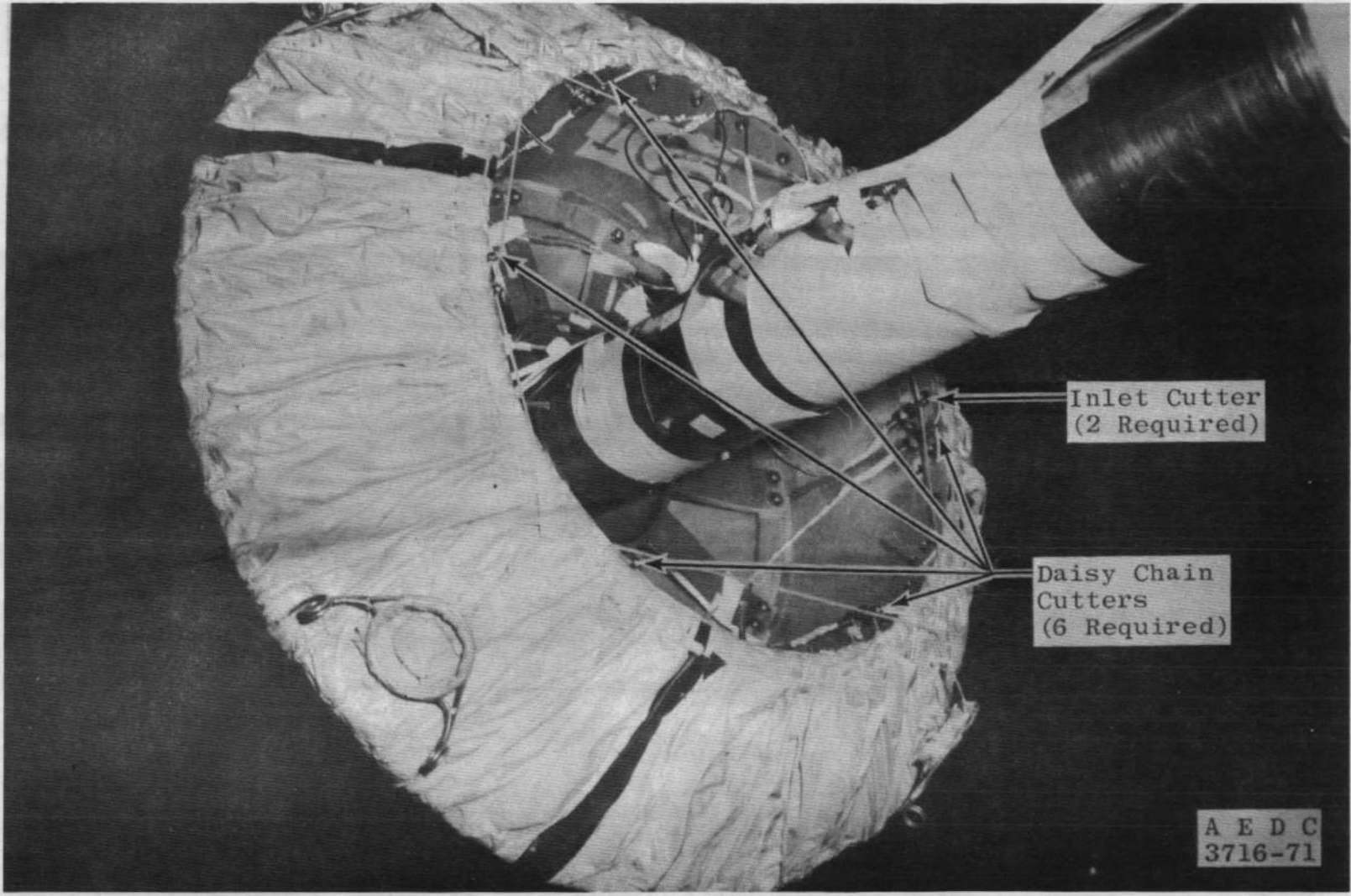

b. Rear Three-Quarter View
Fig. 5 Concluded

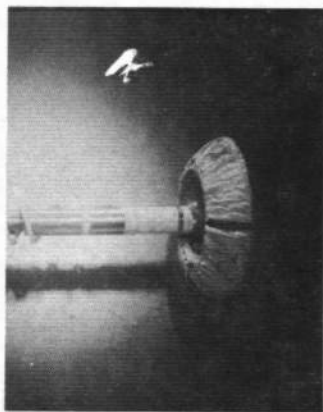

$\alpha = 0$, Undeployed

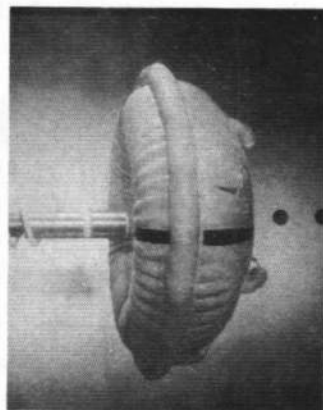

$\alpha = 0$, Deployed

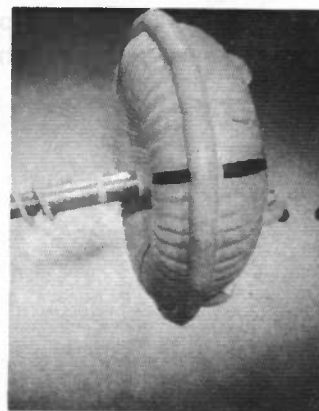

$\alpha = 10$

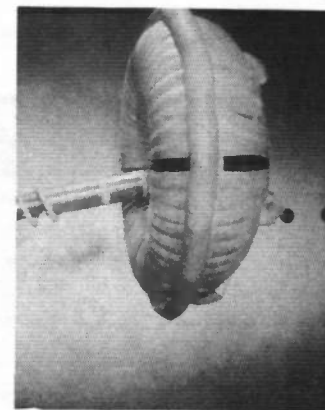

$\alpha = 10$, Pivotal Adaptor Unlocked

a. Model 1, $M_\infty = 3.0$, $q_\infty = 120$ psf

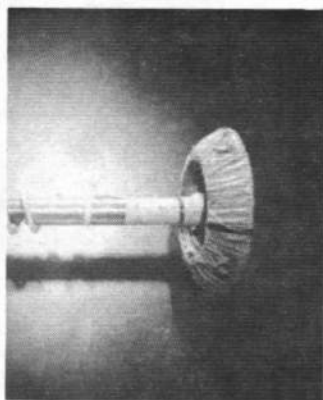

$\alpha = 0$, Undeployed

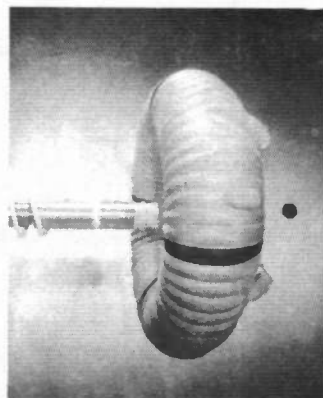

$\alpha = 0$, Deployed

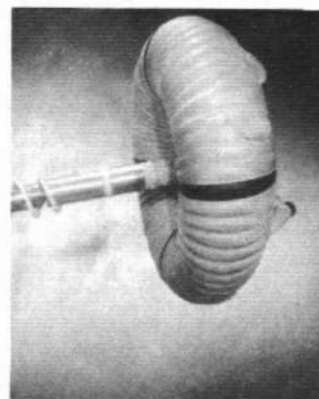

$\alpha = 10$

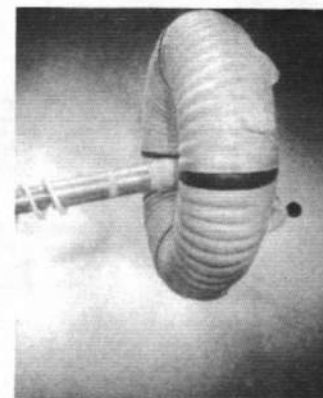

$\alpha = 10$, Pivotal Adaptor Unlocked

b. Model 4, $M_\infty = 3.0$, $q_\infty = 120$ psf

Fig. 6 Photographs of Two AID Models at Various Test Conditions

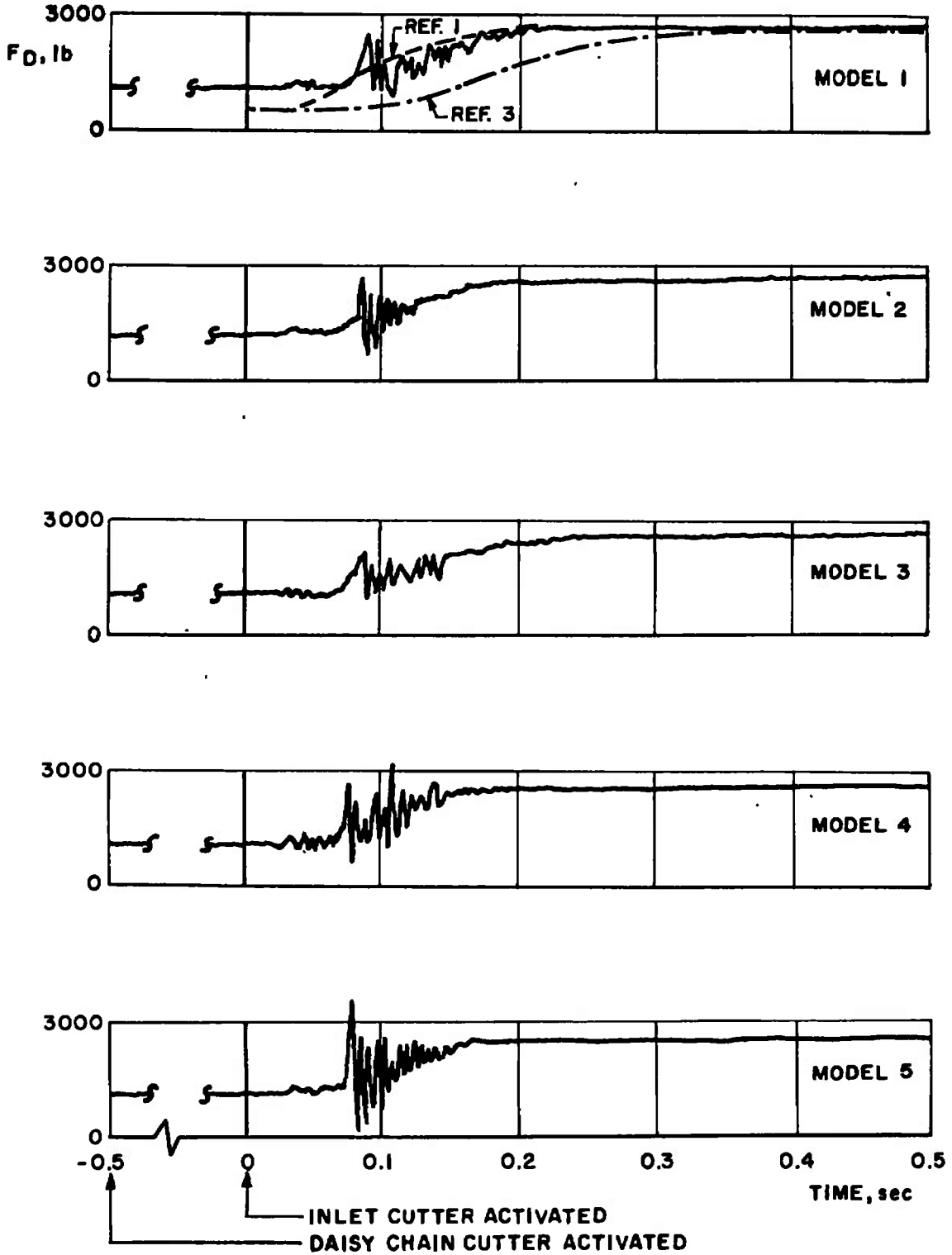

a. Drag Characteristics

Fig. 7 Decelerator Deployment Characteristics at Mach Number 3.0, $q_\infty = 120$ psf

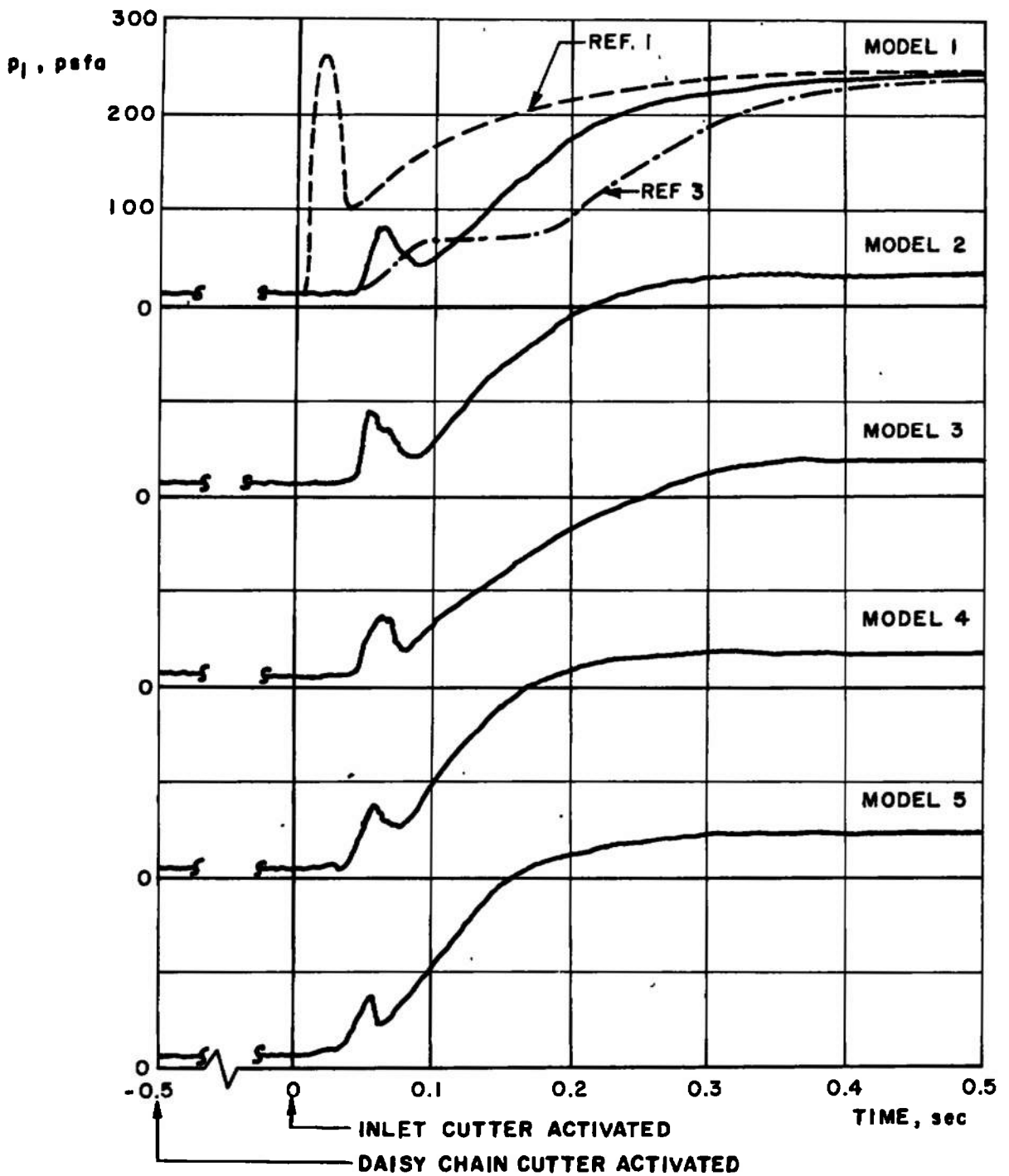

b. Internal Pressure Characteristics
 Fig. 7 Concluded



t = 0 sec



t = 0.05 sec



t = 0.07 sec



t = 0.09 sec



t = 0.11 sec

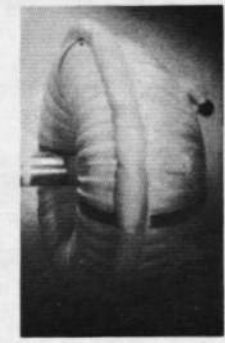

t = 0.20 sec

a. Model 1, $M_\infty = 3.0$, $q_\infty = 120$ psf



t = 0



t = 0.05 sec



t = 0.07 sec



t = 0.09 sec



t = 0.11 sec

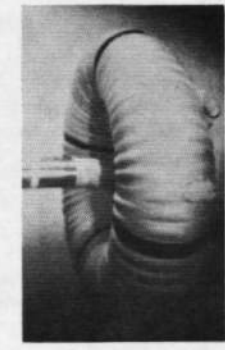

t = 0.18 sec

b. Model 4, $M_\infty = 3.0$, $q_\infty = 120$ psf
Fig. 8 Photographs of the Deployment Sequence

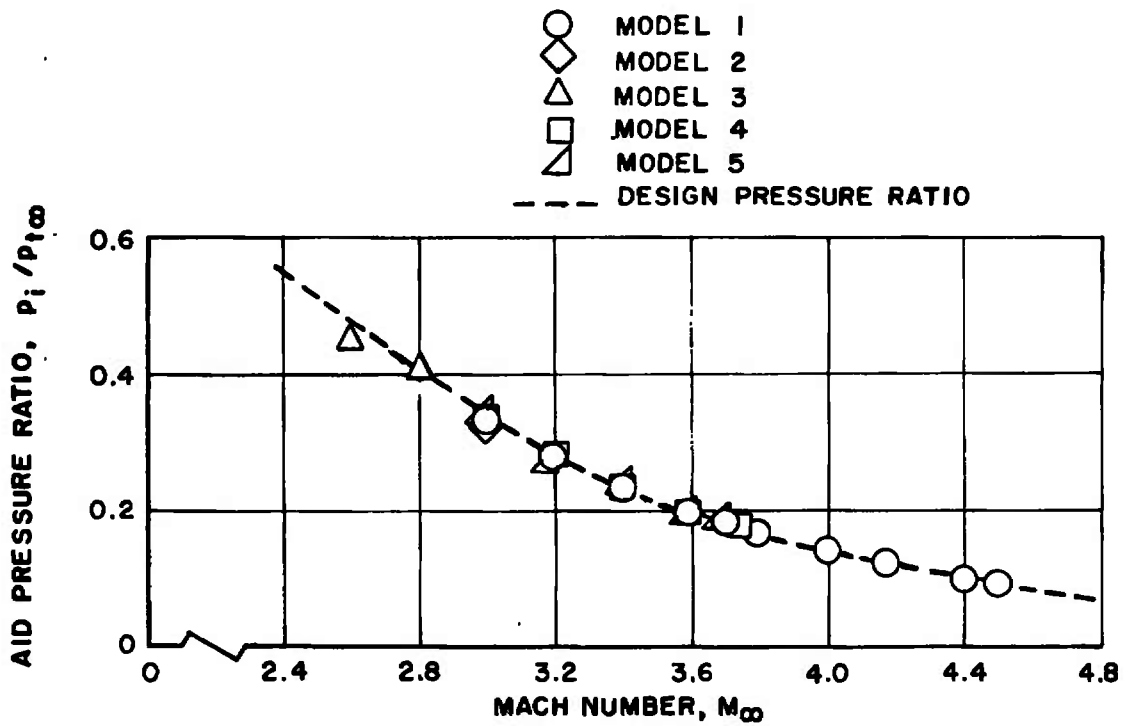
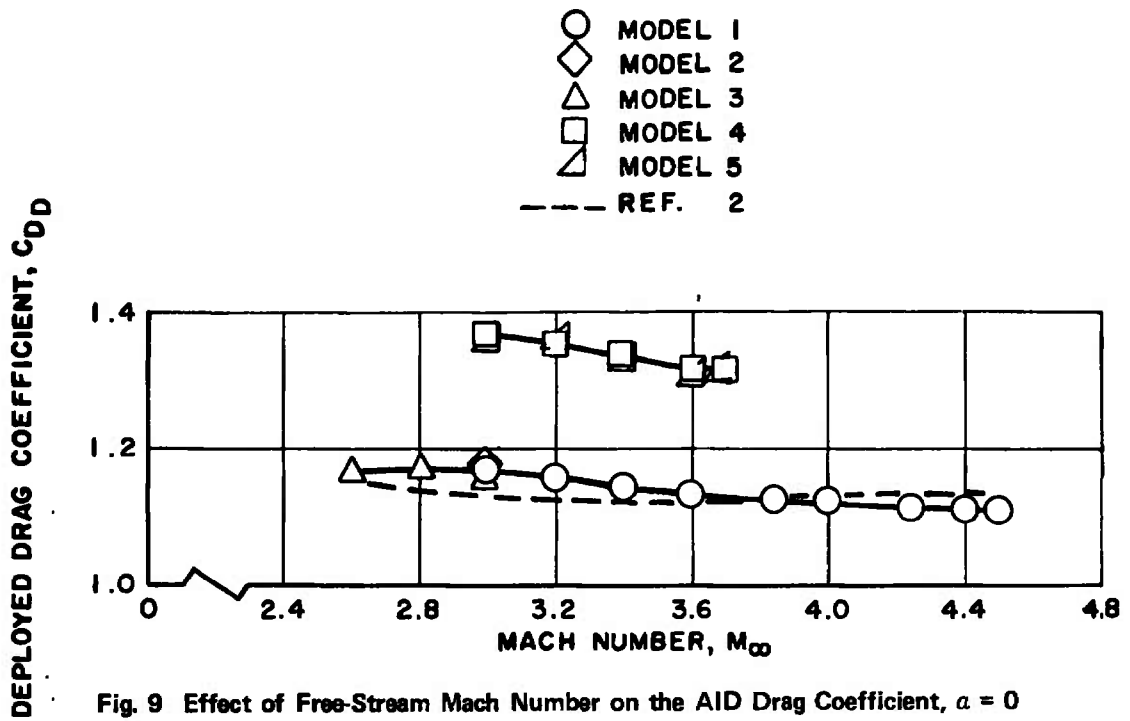

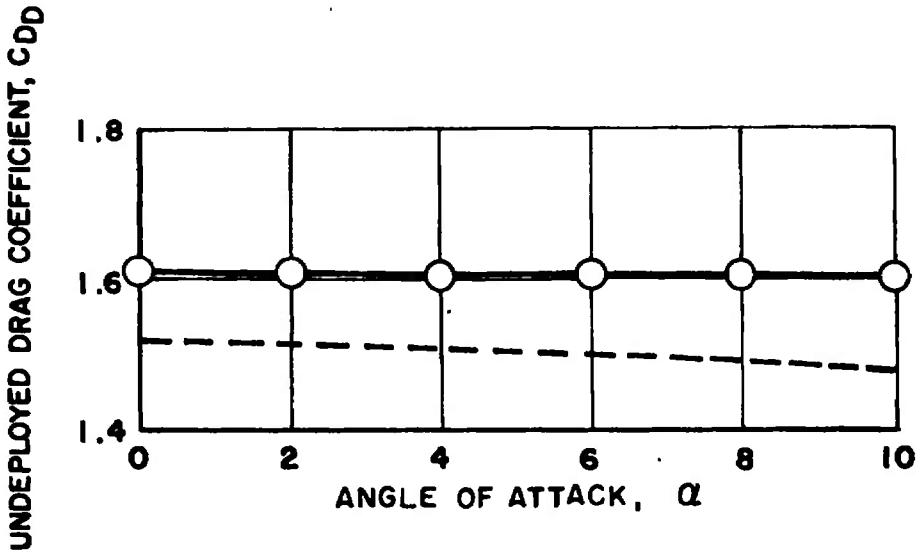

Fig. 11 Effect of Angle of Attack on Drag Coefficient with the AID Model Undeployed

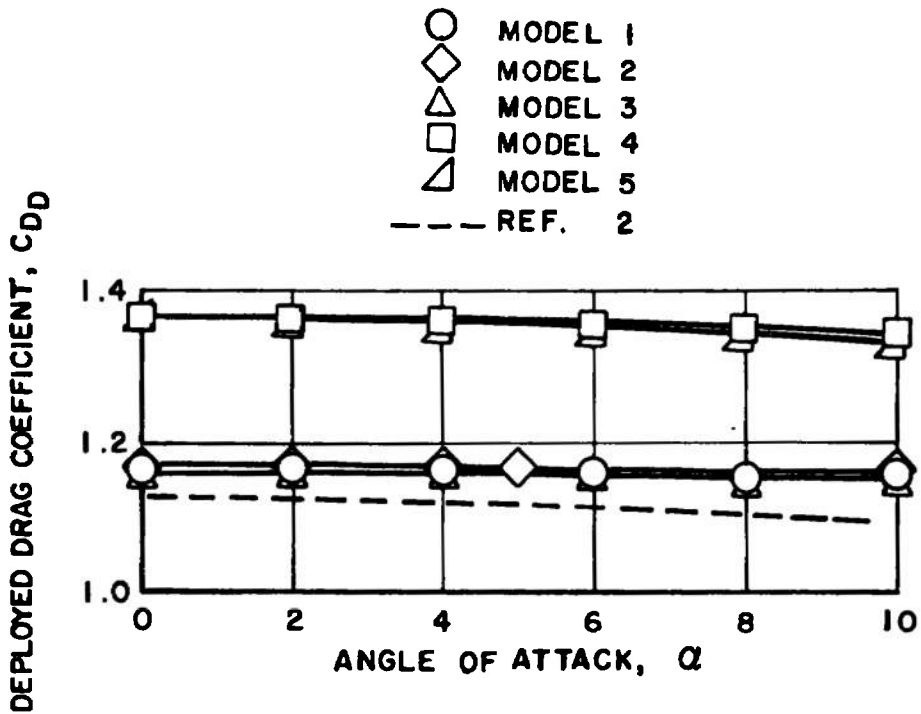

Fig. 12 Effect of Angle of Attack on Drag Coefficient with the AID Model Deployed

DOCUMENT CONTROL DATA - R & D

(Security classification of title, body of abstract and indexing annotation must be entered when the overall report is classified)

| | | | |
|---|---|---|--|
| 1 ORIGINATING ACTIVITY (Corporate author) Arnold Engineering Development Center Arnold Air Force Station, Tennessee 37389 | | 2a. REPORT SECURITY CLASSIFICATION UNCLASSIFIED | |
| | | 2b. GROUP N/A | |
| 3 REPORT TITLE DEPLOYMENT AND PERFORMANCE CHARACTERISTICS OF ATTACHED INFLATABLE DECELERATORS WITH MECHANICALLY DEPLOYED INLETS AT MACH NUMBERS FROM 2.6 TO 4.5 | | | |
| 4 DESCRIPTIVE NOTES (Type of report and inclusive dates) Final Report - May 10 and 11, 1971 | | | |
| 5 AUTHOR(S) (First name, middle initial, last name) David E. A. Reichenau, ARO, Inc. | | | |
| 6 REPORT DATE June 1972 | 7a. TOTAL NO. OF PAGES 29 | 7b. NO. OF REFS 12 | |
| 8a. CONTRACT OR GRANT NO | 9a. ORIGINATOR'S REPORT NUMBER(S) AEDC-TR-72-90 | | |
| b. PROJECT NO | | | |
| c. Program Element 921E | 9b. OTHER REPORT NO(S) (Any other numbers that may be assigned this report) ARO-PWT-TR-71-119 | | |
| d. | | | |
| 10 DISTRIBUTION STATEMENT Approved for public release; distribution unlimited. | | | |
| 11. SUPPLEMENTARY NOTES Available in DDC | | 12. SPONSORING MILITARY ACTIVITY NASA Langley Research Center Hampton, VA 23365 | |

13 ABSTRACT

A test was conducted in the 16-ft Propulsion Wind Tunnel (16S) to determine deployment, inflation, and steady-state characteristics of attached inflatable decelerators. Deployments were made at a Mach number of 3.0 at a free-stream dynamic pressure of 120 psf. The mechanically deployed inlet system resulted in successful deployments of the five test models with rapid inflation times of approximately 0.2 sec. The attached decelerators were very stable throughout the Mach number range from 2.6 to 4.5 and at angles of attack through 10 deg.

| 14. KEY WORDS | LINK A | | LINK B | | LINK C | |
|---|--------|----|--------|----|--------|----|
| | ROLE | WT | ROLE | WT | ROLE | WT |
| Attached Inflatable Decelerator System deceleration inflatable structures steady state performance supersonic flow drag | | | | | | |

AFSC
Armed AP3 Team