

AD 746234

AD

SWERR-TR-72-36

**DEVELOPMENT OF A FINITE ELEMENT APPROACH
FOR APPROXIMATE ANALYSIS OF UNSTEADY COMPRESSIBLE
FLUID FLOW**



TECHNICAL REPORT

Paul E. Ehle and Albert F. Rahe

Reproduced by
NATIONAL TECHNICAL
INFORMATION SERVICE
U.S. Department of Commerce
Springfield, VA 22151

June 1972

DDC
RECEIVED
AUG 9 1972
B

RESEARCH DIRECTORATE

WEAPONS LABORATORY AT ROCK ISLAND

RESEARCH, DEVELOPMENT AND ENGINEERING DIRECTORATE

U. S. ARMY WEAPONS COMMAND

62

DISCLAIMER NOTICE

THIS DOCUMENT IS BEST QUALITY PRACTICABLE. THE COPY FURNISHED TO DTIC CONTAINED A SIGNIFICANT NUMBER OF PAGES WHICH DO NOT REPRODUCE LEGIBLY.

DISTRIBUTION INSTRUCTIONS:

Destroy this report when it is no longer needed. Do not return it to the originator.

DISCLAIMER:

The findings of this report are not to be construed as an official Department of the Army position unless so designated by other authorized documents.

ACCESSION for	
ETIS	White Section <input checked="" type="checkbox"/>
DCC	Red Section <input type="checkbox"/>
UNASSIGNED	<input type="checkbox"/>
JUSTIFICATION	
.....	
BY	
DISTRIBUTION/AVAILABILITY CODES	
Dist.	Avail. Req. or Sp. Dist.
	

Unclassified

Security Classification

DOCUMENT CONTROL DATA - R & D		
<i>(Security classification of title, body of abstract and indexing annotation must be entered when the overall report is classified)</i>		
1. ORIGINATING ACTIVITY (Corporate author) U. S. Army Weapons Command Research, Dev. and Eng. Directorate Rock Island, Illinois 61201		2a. REPORT SECURITY CLASSIFICATION Unclassified
3. REPORT TITLE Development of a Finite Element Approach for Approximate Analysis of Unsteady Compressible Fluid Flow		2b. GROUP
4. DESCRIPTIVE NOTES (Type of report and Inclusive dates)		
5. AUTHOR(S) (First name, middle initial, last name) Paul E. Ehle and Albert E. Rahe		
6. REPORT DATE June 1972	7a. TOTAL NO. OF PAGES 58	7b. NO. OF REFS 9
8a. CONTRACT OR GRANT NO.	9a. ORIGINATOR'S REPORT NUMBER(S) SWERR-TR-72-36	
b. PROJECT NO.	9b. OTHER REPORT NO(S) (Any other numbers that may be assigned this report)	
c. DA 1T061101A91A		
d. AMS Code 501A.11.844		
10. DISTRIBUTION STATEMENT Approved for public release, distribution unlimited.		
11. SUPPLEMENTARY NOTES	12. SPONSORING MILITARY ACTIVITY U. S. Army Weapons Command	
13. ABSTRACT In this report, a finite element method is developed to approximately analyze unsteady compressible gas flow in one spatial dimension. Extension of this analysis to three dimensions is possible. Experimental work to assist in developing and verifying the model has begun, but will be completed and reported at a later date. The present method, as programmed for an IBM 360/65 computer, is suited for a variety of one-dimensional flow situations, but not for those characterized by extremely large rates of pressure change typical of a weapon. The form of the equations is such that heat and mass sources, and sinks, frictional losses, cross-sectional area changes, and other quantities of engineering significance can readily be incorporated. This analysis is not intended to be exact, but is to serve as a mathematical model to approximate some of the dynamic phenomena in gas flow. This work is part of a continuing effort by the Research Directorate, Weapons Laboratory at Rock Island, to explore the basic mechanisms of gas flow.		

DD FORM 1473
1 NOV 65

REPLACES DD FORM 1473, 1 JAN 64, WHICH IS OBSOLETE FOR ARMY USE.

Unclassified

Security Classification

1a

Unclassified

Security Classification

14 KEY WORDS	LINK A		LINK B		LINK C	
	ROLE	WT	ROLE	WT	ROLE	WT
1. Finite Elements						
2. Gas Dynamics						
3. Partial Differential Equations						
4. Fluid Mechanics						
5. Numerical Methods						
6. Mathematical Model						

16

Unclassified

Security Classification

AD

RESEARCH DIRECTORATE
WEAPONS LABORATORY AT ROCK ISLAND
RESEARCH, DEVELOPMENT AND ENGINEERING DIRECTORATE
U. S. ARMY WEAPONS COMMAND

TECHNICAL REPORT
SWERR-TR-72-36

DEVELOPMENT OF A FINITE ELEMENT APPROACH
FOR APPROXIMATE ANALYSIS OF UNSTEADY COMPRESSIBLE
FLUID FLOW

Paul E. Ehle
and
Albert E. Rahe

June 1972

DA 1T061101A91A

AMS Code 501A.11.844

Approved for public release, distribution unlimited.

ABSTRACT

In this report, a finite element method is developed to approximately analyze unsteady compressible gas flow in one spatial dimension. Extension of this analysis to three dimensions is possible. Experimental work to assist in developing and verifying the model has begun, but will be completed and reported at a later date. The present method, as programmed for an IBM 360/65 computer, is suited for a variety of one-dimensional flow situations, but not for those characterized by extremely large rates of pressure change typical of a weapon. The form of the equations is such that heat and mass sources, and sinks, frictional losses, cross-sectional area changes, and other quantities of engineering significance can readily be incorporated. This analysis is not intended to be exact, but is to serve as a mathematical model to approximate some of the dynamic phenomena in gas flow. This work is part of a continuing effort by the Research Directorate, Weapons Laboratory at Rock Island, to explore the basic mechanisms of gas flow.

CONTENTS

	<u>Page</u>
Title Page	i
Abstract	ii
Table of Contents	iii
Acknowledgment	iv
Objective	1
Introduction	1
Approach	2
Governing Equations	5
Techniques Explored for Solving the Equations	14
Results and Conclusions	16
Recommendations for Future Work	21
Literature Cited	22
Appendices	
A. Computer Program with Assumed Linear Distributions	23
B. Existence and Uniqueness Proof	38
C. Analog Computer Block Diagram for a Single Element	44
D. Governing Equations with Assumed Parabolic Distributions	46
Distribution	54
DD Form 1473 (Document Control Data - R&D)	57

ACKNOWLEDGMENT

The authors wish to acknowledge the work of Mr. Paul Cacari, Research Directorate, Weapons Laboratory at Rock Island, who provided excellent support for this project using an analog computer.

OBJECTIVE

The objective of this study was to develop a method to approximately analyze unsteady compressible flow by exploitation of certain aspects of the philosophy of finite-element techniques as applied to mechanical structures.

INTRODUCTION

The solution of the basic governing partial differential equations of fluid mechanics is presently impractical for many important flow situations. Thus, approximations and idealizations are required. In structural analysis, a successful approach to complex problems is to first divide a complicated body into elements that can be individually analyzed and then to account for their interactions. The underlying purpose of the present study is to explore the extent to which this basic idea can be applied to some fluid problems.

In general, the finite-element concept is based on representing a continuum by a collection of a finite number of component parts joined at prescribed nodal points. Usually each component is chosen to have a relatively simple geometric shape. Various field quantities are locally described over each element and are assumed to be uniquely defined by their values at the nodes of the element. Thus, each element can be considered to be disjoint for purposes of describing its local behavior. Once the behavior of a typical element is defined, a discrete model of a continuum of almost any shape with arbitrary boundary and initial conditions can be obtained by the connection of elements in an appropriate manner. A variational principle governing the problem at hand is customarily formulated. Such a formulation provides a consistent way to generate analogues of the field equations, which hold in an average sense across each element. However, the use of a variational approach is unnecessary if a well-defined functional is unavailable for the particular problem under consideration. Appropriate forms of the conservation laws can also be used. For viscous flow, no general variational functional exists, and no attempt is made in the present study to use a variational principle.

This study is not designed to provide a rigorous, exact analysis, but rather an approximate model that might provide some of the characteristics of dynamic gas flow at least qualitatively. Some accuracy is willingly compromised for the possible benefits of computational speed and conceptual simplicity.

In many flow situations, series of naturally occurring element types exist such as bends, areas of surface roughness, heat and mass sources and sinks, and changes in cross-sectional area. Seemingly, the equations governing individual elements could be reasonably joined in some fashion analogous to that in structural analysis.

For the simple flow situation chosen to initiate this study, i.e.,

flow into a circular tube with a piston blocking one end, the method of characteristics would probably in many respects be superior. Also, other finite-difference techniques could be applied to the governing partial differential equations. However, many practical problems are characterized by complex geometrical configurations and boundary conditions. To reduce computation time by traditional methods requires non-uniform meshes. The setting up of the difference equations can be difficult in these instances. In looking beyond these traditional methods and toward the finite-element approach, one can anticipate that a versatile method could possibly emerge by which nonuniform meshes, complicated shapes, and complex boundary conditions can be handled in a straightforward manner.

APPROACH

As a first step in this study, literature surveys were made that included finite-element techniques for solids and fluids, and solution methods for simultaneous nonlinear ordinary differential equations. Very little information was found concerning finite-element techniques applied to fluids. All the information that was collected served as background and guidance in developing an approach. The availability of an experimental apparatus to help guide the effort from a physical standpoint was considered to be a valuable asset. With the use of this apparatus, one should be able to explore wide ranges in pressures, temperature, densities, and velocities. Although the initial plan was to study low flow rates, the expectation was that eventually the analysis technique developed could be extended to describe the extreme situations encountered in weapon gas flow. Thus, a test apparatus was constructed that consisted of a highly instrumented M16 Rifle barrel and gas tube. Low flow rates in the gas tube could be achieved by the partial blocking of the gas port. Also, bottled gas could be used instead of propellant gases from a cartridge. Provisions were made for simultaneous measurements of temperature and pressure at many points along the barrel and gas tube. Temperatures at various depths in the barrel wall at several locations could also be monitored. All the test equipment has been procured, and tests will begin in the near future.

The mathematical approach in developing the finite-element method was based on the application of macroscopic balances of mass, momentum, and energy to each element and on the requirement of continuity of various thermodynamic quantities and their derivatives at each node. No similar approach could be found in the literature.

In the macroscopic balances, rate of change of total mass, momentum, or energy contained within a control volume is equated to influx minus efflux of that quantity. In the approach developed, each element is considered a separate control volume. Transformation of the macroscopic balances into such a form that these equations are expressed in terms of pressure, temperature, density, and velocity at the nodes (boundaries of the control volumes) is desirable. The right sides of these equations,

which express influx minus efflux, are already in this form; the left sides expressing rates of change of total quantities are not yet in this form. A key problem is to express, as accurately as possible, the mass, momentum, and energy contained within an element, wholly in terms of pressure, temperature, density, and velocity values at the nodes. One approach is first to assume general forms for the spatial distributions along each element for any three of the four quantities pressure, temperature, density, and velocity. The fourth quantity is determined by the equation of state. The assumed forms could, in principle, be different for each quantity as well as for each element. One possible form

is a power series $Q_i = \sum_{n=0}^K C_{in} (t)x^n$ where $Q_i = \begin{cases} \text{Pressure} \\ \text{Temperature} \\ \text{Velocity} \end{cases}$ and X is

position in one coordinate direction. Other complete sets of base vectors could also be used. Appropriate combinations of these forms are then integrated over the volume of an element so as to give total mass, momentum, and energy contained within the element. The resulting expressions can then be differentiated with respect to time, and the left sides of the macroscopic balances are then in terms of pressure, temperature, density, and velocity values at the nodes. Thus, all the balance equations are now in the desired form.

So that the number of equations is equal to the number of unknowns, additional relations must be found. To determine the values of the unknown $C_{in} (t)$ requires the specification of auxiliary conditions. Reasonable conditions are continuity of pressure, temperature, density, and velocity at each node, and continuity of first and higher order position derivatives at each node. A linear approximation, corresponding to nonzero values of C_{i0} and C_{i1} only, would require continuity of pressure, temperature, density, and velocity with no restrictions on derivatives. A parabolic distribution, corresponding to nonzero values of C_{i0} , C_{i1} , and C_{i2} only, requires, in addition, continuity of first derivatives. Continuity of higher order derivatives would be required for higher degree polynomial approximations in order that a sufficient number of equations exist. The values of C_{in} can thus all be expressed in terms of the thermodynamic quantities at the nodes. These nodal values are the unknowns in the problem.

For completion of the formulation, time histories of the various thermodynamic quantities are required at certain points in the flow field. These histories must be specified so as to yield a physically realistic problem and a mathematically determinate one.

By the approach outlined above, the governing partial differential equations of fluid mechanics are replaced by a set of first order nonlinear, ordinary differential equations in a form convenient for the input of engineering data.

The initial problem selected to develop the method was simple flow through a hollow circular cylinder. In addition to being approximately the type of flow generated in the test apparatus, this motion is also characteristic of stream tubes. The equations were developed to account for variable cross-sectional area, but initially a constant area was assumed. Also, governing equations were developed where the specific heat at constant pressure was expressed as a third-order polynomial in temperature, but initially a constant value was assumed. The cylinder was hypothetically divided into a chain of shorter tubes, or elements, as shown in Figure 1. The output from one element served as input to an adjacent one. Linear distributions across each element were first used, and later parabolic distributions were assumed. Pressure and temperature were specified at the inlet, and velocity was specified at the outlet of the tube. A maximum of sixteen elements was used. The governing equations for this problem are described in the next section of this report.

GOVERNING EQUATIONS

Nomenclature:

t = time (sec)

$\rho(x,t)$ = density (Kg/m³)

$\rho_i(t)$ = density at node i , $i = 1, 2, \dots, n+1$

$v(x,t)$ = velocity (m/sec)

$v_i(t)$ = velocity at node i , $i=1, 2, \dots, n+1$

$T(x,t)$ = temperature (°K)

$T_i(t)$ = temperature at node i , $i=1, 2, \dots, n+1$

$P(x,t)$ = pressure (newtons/m²)

$P_i(t)$ = pressure at node i , $i=1, 2, \dots, n+1$

L_i = element length (m) $i=1, 2, \dots, n$

$\dot{Q}(t)$ = rate heat energy enters an element (newton-m/sec) $i=1, 2, \dots, n$

$\dot{W}(t)$ = rate at which fluid in an element performs mechanical work on its surroundings

R = gas constant (newton-m/Kg-°K)

$\alpha = C_p$ = specific heat at constant pressure (newton-m/Kg-°K)

A = cross-sectional area (m²)

M_{TOT} = total fluid mass in an element (Kg)

\bar{P}_{TOT} = total momentum in an element (Kg-m/sec)

E_{TOT} = total energy in an element (Kg-m²/sec²)

K_{TOT} = total kinetic energy in an element (Kg-m²/sec²)

W = mass flow rate (Kg/sec)

F = force of the fluid on the solid and is composed of the sum of all viscous and pressure forces (newtons)

g = acceleration due to gravity (m/sec²)

$\langle \bar{v} \rangle$ = average velocity of \bar{v} over a cross section

$v = \bar{v} + v'$ \bar{v} = time average value of v at a point

v' = perturbation of v about \bar{v}

$\hat{\cdot}$ = per unit mass

$\hat{U} + P\hat{V}$ = enthalpy per unit mass

$\hat{\phi}$ = potential energy per unit mass

A tube is divided into n-sections called elements as shown in Figure 1.

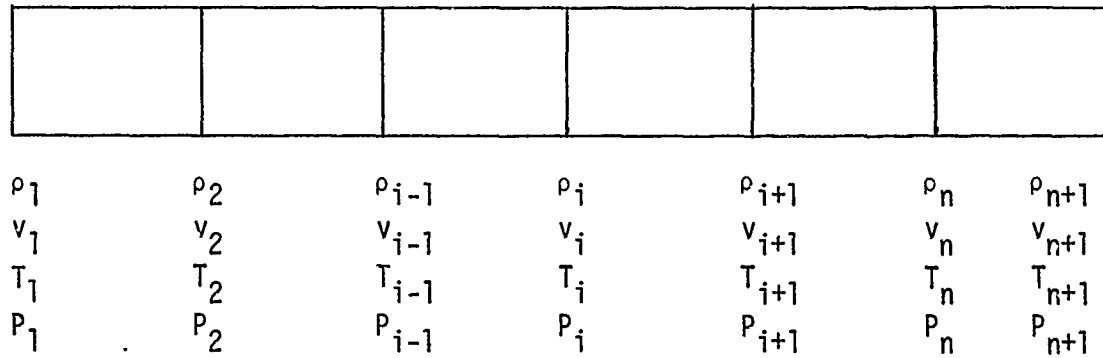

FIGURE 1

The flow in each element is assumed to be governed by the following macroscopic balances for a control volume (Reference 1).

$$\text{Mass: } \frac{d}{dt} M_{TOT} = \rho_i \langle \bar{v}_i \rangle A_i - \rho_{i+1} \langle \bar{v}_{i+1} \rangle A_{i+1}$$

$$\text{Momentum: } \frac{d}{dt} \vec{P}_{TOT} = \left(\frac{\langle \bar{v}^2 \rangle}{\langle \bar{v} \rangle} \vec{W} + P\vec{A} \right)_i - \left(\frac{\langle \bar{v}^2 \rangle}{\langle \bar{v} \rangle} \vec{W} + P\vec{A} \right)_{i+1} - \vec{F} + M_{TOT} \vec{g}$$

$$\text{Energy: } \frac{d}{dt} E_{TOT} = \left[\left(\hat{U} + P\hat{V} + \frac{1}{2} \frac{\langle \bar{v}^3 \rangle}{\langle \bar{v} \rangle} + \hat{\phi} \right) W \right]_i - \left[\left(\hat{U} + P\hat{V} + \frac{1}{2} \frac{\langle \bar{v}^3 \rangle}{\langle \bar{v} \rangle} + \hat{\phi} \right) W \right]_{i+1} + \dot{Q} - \dot{W}$$

$$\text{Where } M_{TOT} = \int \rho dV$$

$$\vec{P}_{TOT} = \int \rho \vec{v} dV$$

$$E_{TOT} = U_{TOT} + K_{TOT} + \phi_{TOT}$$

$$U_{TOT} = \int \rho \hat{u} dV \quad K_{TOT} = \int \frac{1}{2} \rho v^2 dV \quad \phi_{TOT} = \int \rho \hat{\phi} dV$$

For an ideal gas, $P = \rho RT$, $\hat{C}_p - \hat{C}_v = R$

For the present, assume linear distributions across an element.

Then for the first element $\rho = \rho_1 + \frac{\rho_2 - \rho_1}{L} x$

$$A = A_1 + \frac{A_2 - A_1}{L} x$$

$$v = v_1 + \frac{v_2 - v_1}{L} x$$

$$M_{TOT} = \int_0^L \rho dV = \int_0^L \rho A dx = \frac{L}{6} [2\rho_1 A_1 + 2\rho_2 A_2 + \rho_1 A_2 + \rho_2 A_1]$$

$$P_{TOT} = \int_0^L \rho \bar{v} dV = \int_0^L \rho v A dx = \frac{L}{12} [(3A_1 + A_2)\rho_1 v_1 + (A_1 + 3A_2)\rho_2 v_2$$

$$+ (A_1 + A_2)(\rho_1 v_2 + \rho_2 v_1)]$$

$$K_{TOT} = \frac{1}{2} \int_0^L \rho v^2 dV = \frac{L}{2} \{v_1^2 [A_1 (\frac{1}{5} \rho_1 + \frac{1}{20} \rho_2) + A_2 (\frac{1}{20} \rho_1 + \frac{1}{30} \rho_2)]$$

$$+ v_2^2 [A_1 (\frac{1}{30} \rho_1 + \frac{1}{20} \rho_2) + A_2 (\frac{1}{20} \rho_1 + \frac{1}{5} \rho_2)]$$

$$+ v_1 v_2 [A_1 (\frac{1}{10} \rho_1 + \frac{1}{15} \rho_2) + A_2 (\frac{1}{15} \rho_1 + \frac{1}{10} \rho_2)]\}$$

$$\begin{aligned}
U_{TOT} &= \int_0^L \rho \hat{U} dV = \int_0^L \rho \int_0^T \hat{C}_V dT dV \\
&= L \left\{ \rho_2 \frac{\hat{C}_p - R}{12} [(A_1 + 3A_2)T_1 + A_1T_1 + A_2T_1] + T_2 \frac{\hat{C}_p - R}{12} [A_1\rho_1 + A_2\rho_1 \right. \\
&\quad \left. + \rho_1(A_1 + 3A_2)] + \frac{\hat{C}_p - R}{12} [-\rho_1T_1(3A_2 + A_1) + \rho_1T_1(3A_1 + A_2)] \right\}
\end{aligned}$$

Calculations were also made on the assumption that \hat{C}_V is a third-degree polynomial in T. (The results are too lengthy to present here.)

Now assume that the cross-sectional area is constant and that the element lengths are variable. The above-cited equations, when applied to the whole system of elements, become, after much algebraic manipulation, the following:

$$[1] \dot{\rho}_2 = \frac{2}{L_1} \{ \rho_1 v_1 - \rho_2 v_2 \} - \dot{\rho}_1 \quad (\text{Mass})$$

$$[4v_2 + 2v_1]\dot{\rho}_2 + [4\rho_1 + 2\rho_2]\dot{v}_1 + [2\rho_1 + 4\rho_2]\dot{v}_2 = \quad (\text{Momentum})$$

$$- \{4v_1 + 2v_2\}\dot{\rho}_1 - \frac{12}{L_1} \{ \rho_2 v_2^2 - \rho_1 v_1^2 + R\rho_2 T_2 - R\rho_1 T_1 \}$$

$$\left[\frac{v_1^2}{24} + \frac{v_2^2}{8} + \frac{v_1 v_2}{12} + \frac{\alpha - R}{12} (4T_2 + 2T_1) \right] \dot{\rho}_2 \quad (\text{Energy})$$

$$+ \left[v_1 \left(\frac{\rho_1}{4} + \frac{\rho_2}{12} \right) + \frac{v_2}{12} (\rho_1 + \rho_2) \right] \dot{v}_1$$

$$+ \left[v_2 \left(\frac{\rho_1}{12} + \frac{\rho_2}{4} \right) + \frac{v_1}{12} (\rho_1 + \rho_2) \right] \dot{v}_2 +$$

$$\left[\frac{\alpha - R}{12} (2\rho_1 + 4\rho_2) \right] \dot{T}_2 =$$

$$\begin{aligned}
& - \left\{ \frac{v_1^2}{8} + \frac{v_2^2}{24} + \frac{v_1 v_2}{12} + \frac{\alpha-R}{12} (2T_2 + 4T_1) \right\} \dot{\rho}_1 \\
& - \left\{ \frac{\alpha-R}{12} (4\rho_1 + 2\rho_2) \right\} \dot{T}_1 \\
& + \frac{1}{L_1} \left\{ \alpha(\rho_1 v_1 T_1 - \rho_2 v_2 T_2) + \frac{1}{2} \rho_1 v_1^3 - \frac{1}{2} \rho_2 v_2^3 \right\} + \frac{\dot{Q}_1 - \dot{W}_1}{AL_1}
\end{aligned}$$

For $i = 2, 3 \dots n - 1$

$$[1] \dot{\rho}_i + [1] \dot{\rho}_{i+1} = \frac{2}{L_i} \{ \rho_i v_i - \rho_{i+1} v_{i+1} \} \quad (\text{Mass})$$

$$[4v_i + 2v_{i+1}] \dot{\rho}_i + [4v_{i+1} + 2v_i] \dot{\rho}_{i+1} \quad (\text{Momentum})$$

$$\begin{aligned}
& + [4\rho_i + 2\rho_{i+1}] \dot{v}_i + [2\rho_i + 4\rho_{i+1}] \dot{v}_{i+1} \\
& = - \frac{12}{L_i} \{ \rho_{i+1} v_{i+1}^2 - \rho_i v_i^2 + R\rho_{i+1} T_{i+1} - R\rho_i T_i \}
\end{aligned}$$

$$\left[\frac{v_i^2}{8} + \frac{v_{i+1}^2}{24} + \frac{v_i v_{i+1}}{12} + \frac{\alpha-R}{12} (2T_{i+1} + 4T_i) \right] \dot{\rho}_i \quad (\text{Energy})$$

$$+ \left[\frac{v_i^2}{24} + \frac{v_{i+1}^2}{8} + \frac{v_i v_{i+1}}{12} + \frac{\alpha-R}{12} (4T_{i+1} + 2T_i) \right] \dot{\rho}_{i+1}$$

$$+ \left[v_i \left(\frac{\rho_i}{4} + \frac{\rho_{i+1}}{12} \right) + \frac{v_{i+1}}{12} (\rho_i + \rho_{i+1}) \right] \dot{v}_i$$

$$+ \left[v_{i+1} \left(\frac{\rho_i}{12} + \frac{\rho_{i+1}}{4} \right) + \frac{v_i}{12} (\rho_i + \rho_{i+1}) \right] \dot{v}_{i+1}$$

$$+ \left[\frac{\alpha-R}{12} (4\rho_i + 2\rho_{i+1}) \right] \dot{T}_i + \left[\frac{\alpha-R}{12} (2\rho_i + 4\rho_{i+1}) \right] \dot{T}_{i+1}$$

$$= \frac{1}{L_i} \left\{ \alpha(\rho_i v_i T_i - \rho_{i+1} v_{i+1} T_{i+1}) + \frac{1}{2} \rho_i v_i^3 - \frac{1}{2} \rho_{i+1} v_{i+1}^3 \right\} + \frac{\dot{Q}_i - \dot{W}_i}{AL_i}$$

Finally

$$[1] \dot{\rho}_n + [1] \dot{\rho}_{n+1} = \frac{2}{L_n} \{ \rho_n v_n - \rho_{n+1} v_{n+1} \} \quad (\text{Mass})$$

$$[4v_n + 2v_{n+1}] \dot{\rho}_n + [4v_{n+1} + 2v_n] \dot{\rho}_{n+1} + [4\rho_n + 2\rho_{n+1}] \dot{v}_n \quad (\text{Momentum})$$

$$= - \{ 2\rho_n + 4\rho_{n+1} \} \dot{v}_{n+1} - \frac{12}{L} \{ \rho_{n+1} v_{n+1}^2 - \rho_n v_n^2$$

$$+ R\rho_{n+1} T_{n+1} - R\rho_n T_n \}$$

$$\left[\frac{v_n^2}{8} + \frac{v_{n+1}^2}{24} + \frac{v_n v_{n+1}}{12} + \frac{(\alpha-R)}{12} (2T_{n+1} + 4T_n) \right] \dot{\rho}_n + \quad (\text{Energy})$$

$$\left[\frac{v_n^2}{24} + \frac{v_{n+1}^2}{8} + \frac{v_n v_{n+1}}{12} + \frac{\alpha-R}{12} (4T_{n+1} + 2T_n) \right] \dot{\rho}_{n+1}$$

$$+ \left[v_n \left(\frac{\rho_n}{4} + \frac{\rho_{n+1}}{12} \right) + \frac{v_{n+1}}{12} (\rho_n + \rho_{n+1}) \right] \dot{v}_n$$

$$+ \left[\frac{\alpha-R}{12} (4\rho_n + 2\rho_{n+1}) \right] \dot{T}_n + \left[\frac{\alpha-R}{12} (2\rho_n + 4\rho_{n+1}) \right] \dot{T}_{n+1}$$

$$= - \left\{ v_{n+1} \left(\frac{\rho_n}{12} + \frac{\rho_{n+1}}{4} \right) + \frac{v_n}{12} (\rho_n + \rho_{n+1}) \right\} \dot{v}_{n+1} +$$

$$\frac{1}{L_n} \left\{ \alpha (\rho_n v_n T_n - \rho_{n+1} v_{n+1} T_{n+1}) + \frac{1}{2} \rho_n v_n^3 - \frac{1}{2} \rho_{n+1} v_{n+1}^3 \right\} + \frac{\dot{Q}_n - \dot{W}_n}{AL_n}$$

The previous equations are of the form $A(x,t)\dot{x} = F(x,t)$ where $A(x,t)$ is a $3n \times 3n$ matrix function.

$\dot{x} = (\dot{v}_1, \dot{\rho}_2, \dot{v}_2, \dot{T}_2, \dots, \dot{\rho}_n, \dot{v}_n, \dot{T}_n, \dot{\rho}_{n+1}, \dot{T}_{n+1})^T$ and $F(x,t)$ is a $nx1$ column vector function. The initial state of the gas is known and we specify it as, x_0 .

$$A_j = 4v_j + 2v_{j+1}$$

$$B_i = 4v_{i+1} + 2v_i$$

$$C_i = 4\rho_i + 2\rho_{i+1}$$

$$D_i = 2\rho_i + 4\rho_{i+1}$$

$$E_i = \frac{v_i^2}{8} + \frac{v_{i+1}^2}{24} + \frac{v_i v_{i+1}}{12} + \frac{\alpha-R}{12} (2T_{i+1} + 4T_i)$$

$$F_i = \frac{v_i^2}{24} + \frac{v_{i+1}^2}{8} + \frac{v_i v_{i+1}}{12} + \frac{\alpha-R}{12} (4T_{i+1} + 2T_i)$$

$$G_i = v_i \left(\frac{\rho_i}{4} + \frac{\rho_{i+1}}{12} \right) + \frac{v_{i+1}}{12} (\rho_i + \rho_{i+1})$$

$$H_i = v_{i+1} \left(\frac{\rho_i}{12} + \frac{\rho_{i+1}}{4} \right) + \frac{v_i}{12} (\rho_i + \rho_{i+1})$$

$$J_i = \frac{\alpha-R}{12} (4\rho_i + 2\rho_{i+1})$$

$$K_i = \frac{\alpha-R}{12} (2\rho_i + 4\rho_{i+1})$$

$$X_i = \frac{2}{L_i} \{ \rho_i v_i - \rho_{i+1} v_{i+1} \}$$

$$Y_i = -\frac{12}{L_i} \{ \rho_{i+1} v_{i+1}^2 - \rho_i v_i^2 + R\rho_{i+1} T_{i+1} - R\rho_i T_i \}$$

$$Z_i = \frac{1}{L_i} \{ \alpha (\rho_i v_i T_i - \rho_{i+1} v_{i+1} T_{i+1})$$

$$+ \frac{1}{2} \rho_i v_i^3 - \frac{1}{2} \rho_{i+1} v_{i+1}^3 \} + \frac{\dot{Q}_i - \dot{W}_i}{AL_i}$$

Now define $F(x,t)$:

$F(x,t) =$

$$\begin{array}{l} X_1 - \dot{\rho}_1 \\ Y_1 - A_1 \dot{\rho}_1 \\ Z_1 - E_1 \dot{\rho}_1 - J_1 \dot{t}_1 \\ X_2 \\ Y_2 \\ Z_2 \\ \cdot \\ \cdot \\ \cdot \\ X_n \\ Y_n - D_n \dot{v}_{n+1} \\ Z_n - H_n \dot{v}_{n+1} \end{array}$$

Note that ρ_1 , T_1 , and v_{n+1} are specified functions of time. P_1 and T_1 are known, and ρ_1 is determined from $\rho_1 = \frac{P_1}{RT_1}$ and $\dot{\rho}_1 = \frac{\dot{P}_1}{RT_1} - \frac{P_1 \dot{T}_1}{RT_1^2}$

$$= \rho_1 \left(\frac{\dot{P}_1}{P_1} - \frac{\dot{T}_1}{T_1} \right)$$

A total of $3n$ equations must be solved. The unknown parameters are $v_1, \rho_2, v_2, T_2, \rho_3, v_3, T_3, \dots, \rho_n, v_n, T_n, \rho_{n+1}, T_{n+1}$. The functions ρ_1, T_1, v_{n+1} and their derivatives are given.

TECHNIQUES EXPLORED FOR SOLVING THE EQUATIONS

A number of approaches were taken to find a stable algorithm for solving the system of nonlinear, first-order, ordinary differential equations resulting from the application of the finite-element method to the hollow cylinder. These are briefly reviewed below:

1. The initial approach was to replace derivatives by finite differences and then solve the resulting system of algebraic equations to find pressure, temperature, density, and velocity changes at each node for a small change in time. Even with very small time-increments, however, the solution failed to converge. A practical limit exists as to how small a time increment can be. As the increment is reduced, many more calculations must be performed. Round-off error begins to grow, and accuracy is destroyed just as surely as if very large time-increments were used.
2. Next, a fourth-order Runge-Kutta method was tried. This technique was stable for small time-rates of change and for long time-spans after flow initiation. This technique ultimately became the most successful of the numerical techniques explored.
3. A modified Hamming predictor-corrector method, which is a standard IBM integration routine, was also applied to the equations. With this technique, the integration interval was automatically subdivided to meet a specified accuracy. However, stability of this method was not as good as that of the fourth-order Runge-Kutta algorithm. Also, this method was more expensive to run.
4. A fifth-order Runge-Kutta method was also used. However, it was less stable than the fourth-order Runge-Kutta technique. This instability could be attributed to the larger number of derivative evaluations that were required.

5. Various attempts were made to linearize the system of equations and then to analytically solve a sequence of linear differential equations with constant coefficients valid over one time-interval. However, this approach always resulted in an eigenvalue problem; and the corresponding matrix is not symmetric. This approach apparently would have been less successful than the Runge-Kutta.

6. Normally, pressure and temperature were specified functions of time at one end of the tube, and velocity was specified at the other. Various combinations of specified quantities at different locations were evaluated for their effect on stability. Some of these combinations resulted in a coefficient matrix that was singular. Two combinations without this problem are given below:

a. Specifying the pressure and temperature at one end of the tube, and velocity at the other;

b. Specifying pressure, temperature, and velocity all at one end.

7. Methods were developed and applied to allow shock-wave type of discontinuities in the thermodynamic quantities where instability was imminent. This approach only slightly delayed numerical instability.

8. Linear distributions across individual elements were replaced by second-degree polynomial (parabolic) distributions for purposes of calculating total mass, momentum, and energy within an element. For evaluation of the additional coefficients C_{i2} , all first derivatives were assumed to be continuous at each node. Computation time was considerably increased since the coefficient matrix was not banded. Stability was not significantly increased, but oscillations of values at the nodes were noticeably reduced. In Appendix D, equations for the parabolic distribution are presented.

9. A movable piston was placed at the closed end of the tube, and the fluid velocity was constrained to be equal to the piston velocity. The pressure acting on the piston face was used in Newton's second law to determine this velocity. Stability was only slightly delayed by this modification. (Ordinarily, the velocity at one end was constrained to be zero.)

10. A COMCOR CI 5000 analog computer was used to solve the equations governing first one element and then two elements. Good agreement was achieved between analog and digital results. With the use of the analog computer, the equations were solved for quite high rates of change that led to instabilities in the digital approach. The analog computer had an insufficient number of multipliers to solve the equations for more than two elements.

11. The equations were made nondimensional to determine whether higher time rates of change could somehow be more easily accommodated. No appreciable improvement was found.

RESULTS AND CONCLUSIONS

For the assumption of linear spatial distributions and for the case of flow into an initially quiescent tube blocked at one end, the propagation of a velocity wave and its reflection from the closed end can be seen in Figure 2. Relatively small oscillations of pressure, velocity, and temperature above and below the "zero line" and downstream of the advancing wave are evident in Figures 3, 4, and 5. These oscillations greatly diminish at nodal points when parabolic distributions are assumed.

Of all the numerical techniques tried, the fourth-order Runge-Kutta algorithm appeared to be the most stable. However, even with this method, the solution became unstable if very high rates of change in the thermodynamic quantities were present. For example, if the initial rate of change of pressure was about one atmosphere per millisecond, the velocity wave was propagated to the blocked end of the tube, was reflected, and was returned no more than halfway before the solution became unstable. As initial rates of change were reduced, the onset of instability was delayed.

Dependent upon how high the rates of change of thermodynamic quantities are and how long after flow initiation the solution is desired, some practical problems can be solved with the present finite-element method on an IBM 360/55 computer. The most promising approaches for extending the region of applicability of the method lie in the use of a hybrid computer and higher order distributions. Where this method is applicable, it is quite versatile; is well suited to handle area changes, friction, and mass sources and sinks; and is conceptually straightforward. This method, moreover, could be extended to three dimensions.

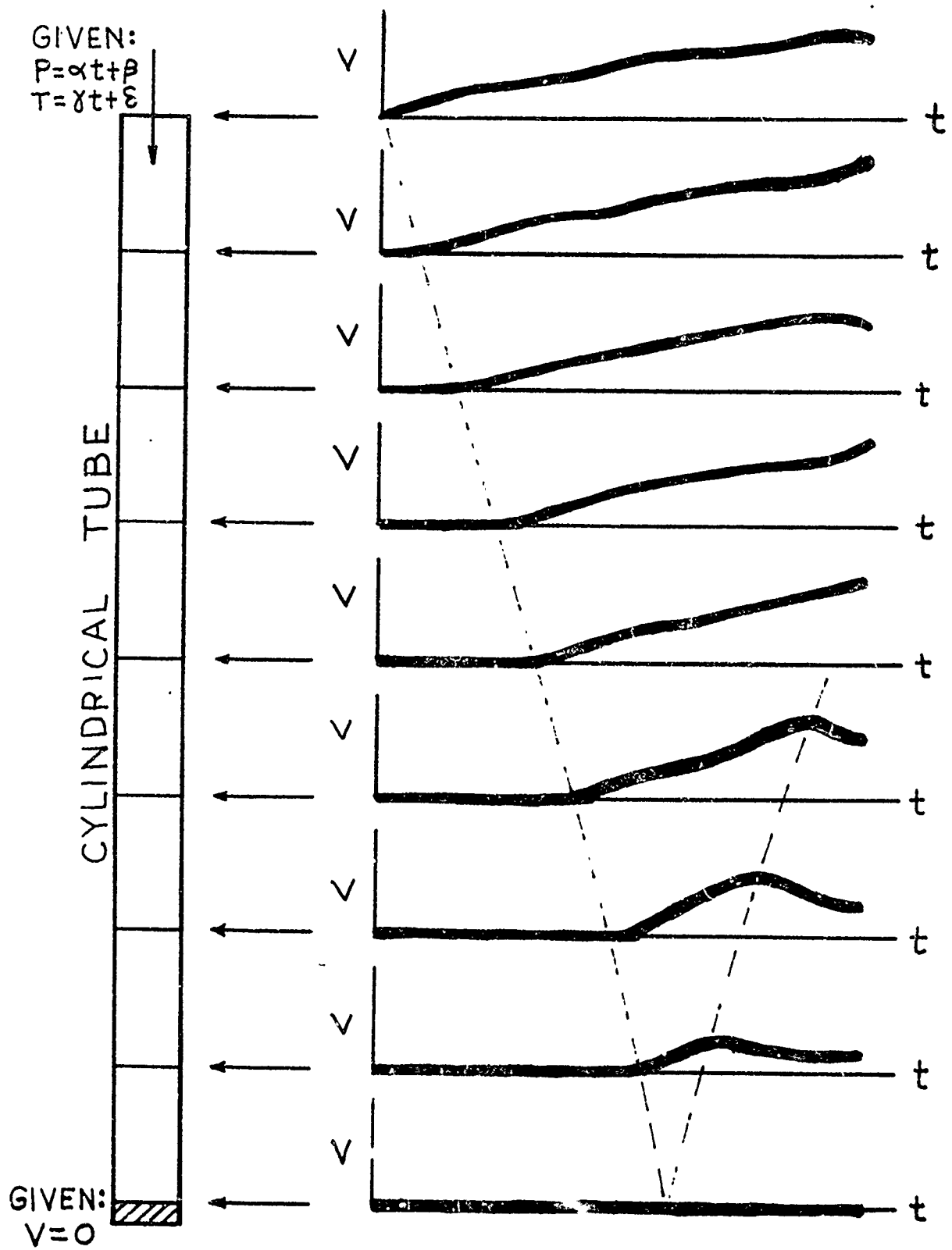

FIGURE 2

Velocity histories at nodal points along the tube. Pressure and temperature are specified steadily increasing linear functions of time, and velocity at the closed end is specified to be zero. Linear distributions across each element are assumed.

FIGURE 3 Pressure versus position along the tube.
 Lines beginning at higher pressures correspond
 to later times. Zero distance corresponds to
 the open end of the tube.

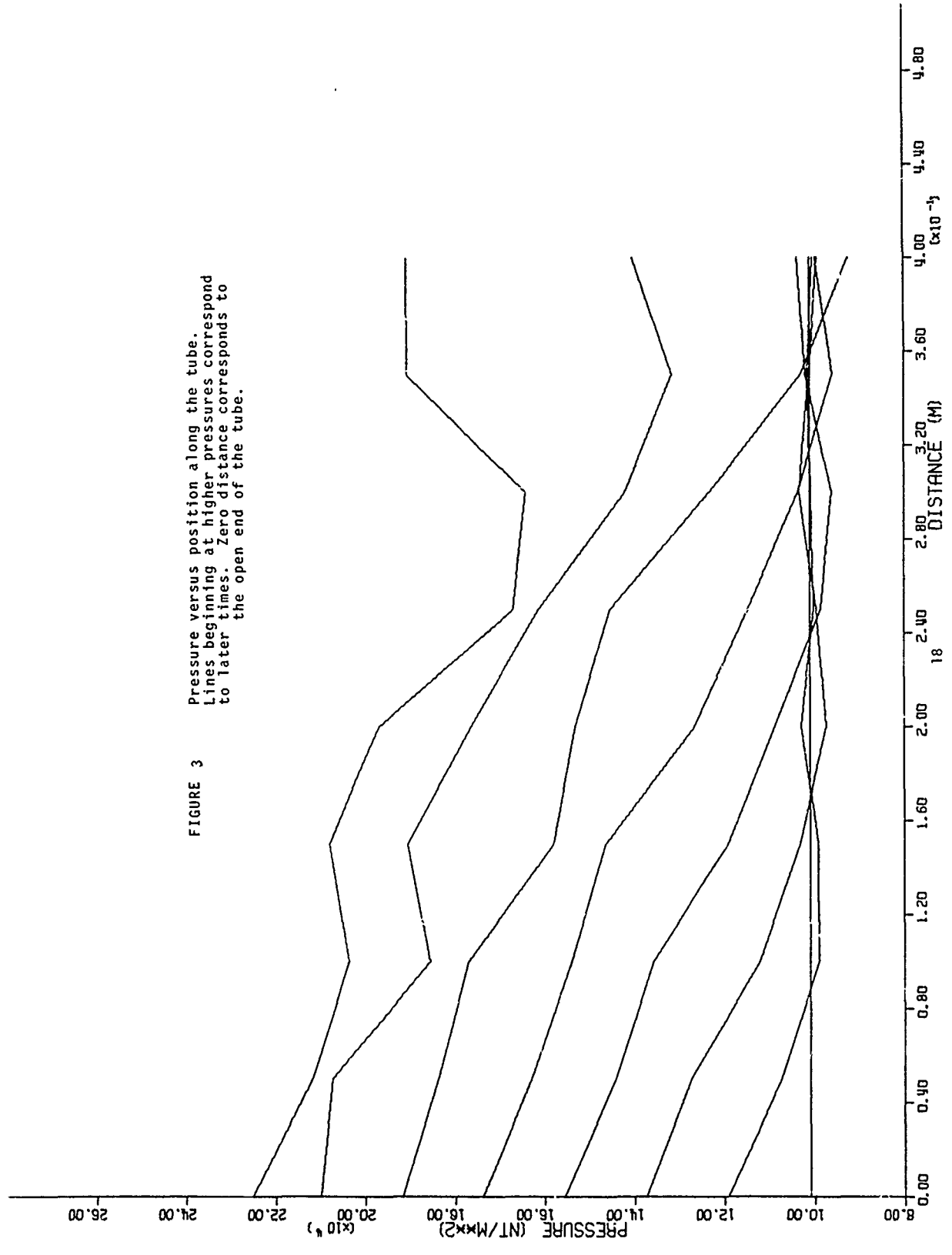

FIGURE 4 Velocity versus position along the tube.
Lines beginning at higher velocities
correspond to later times.

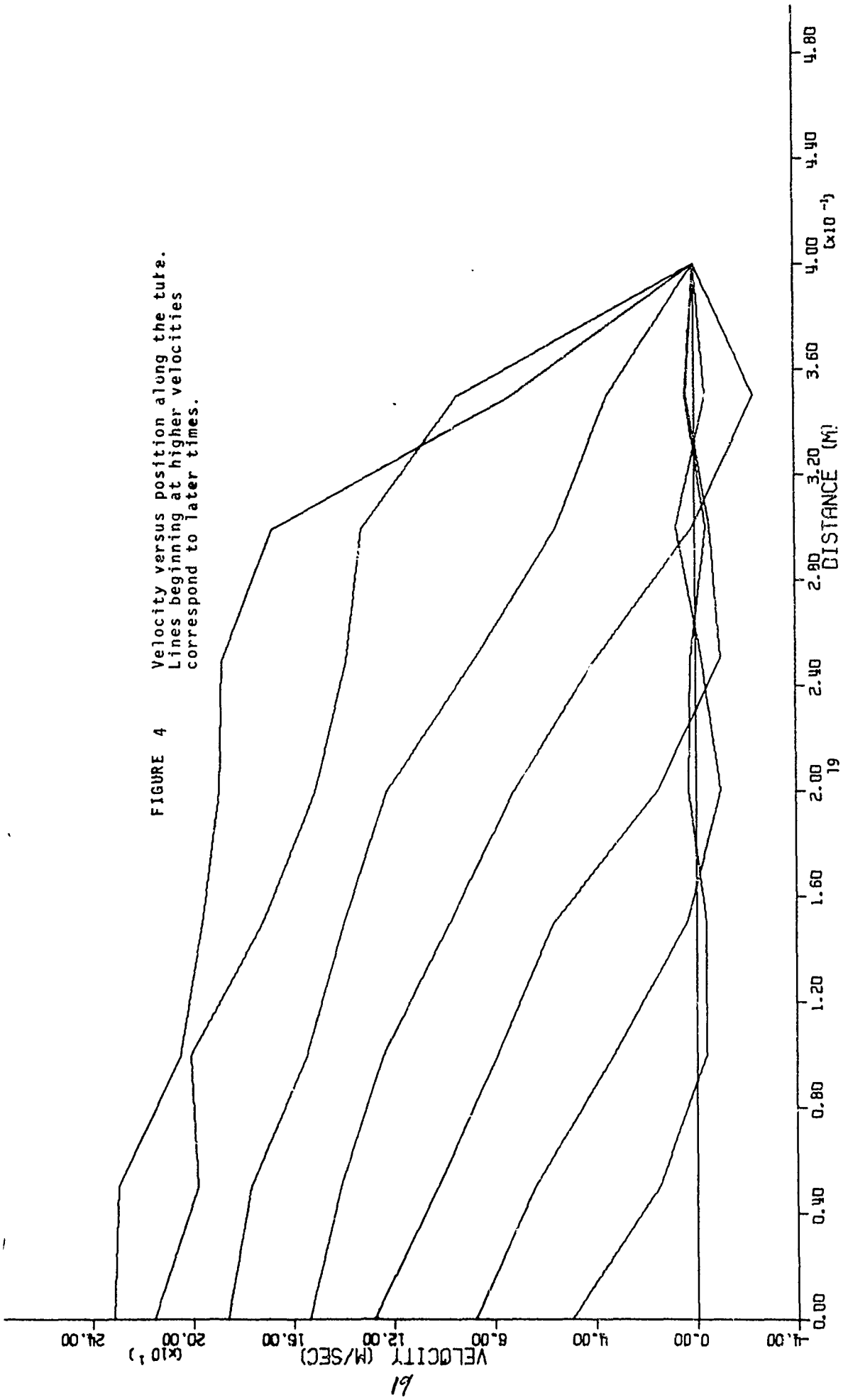
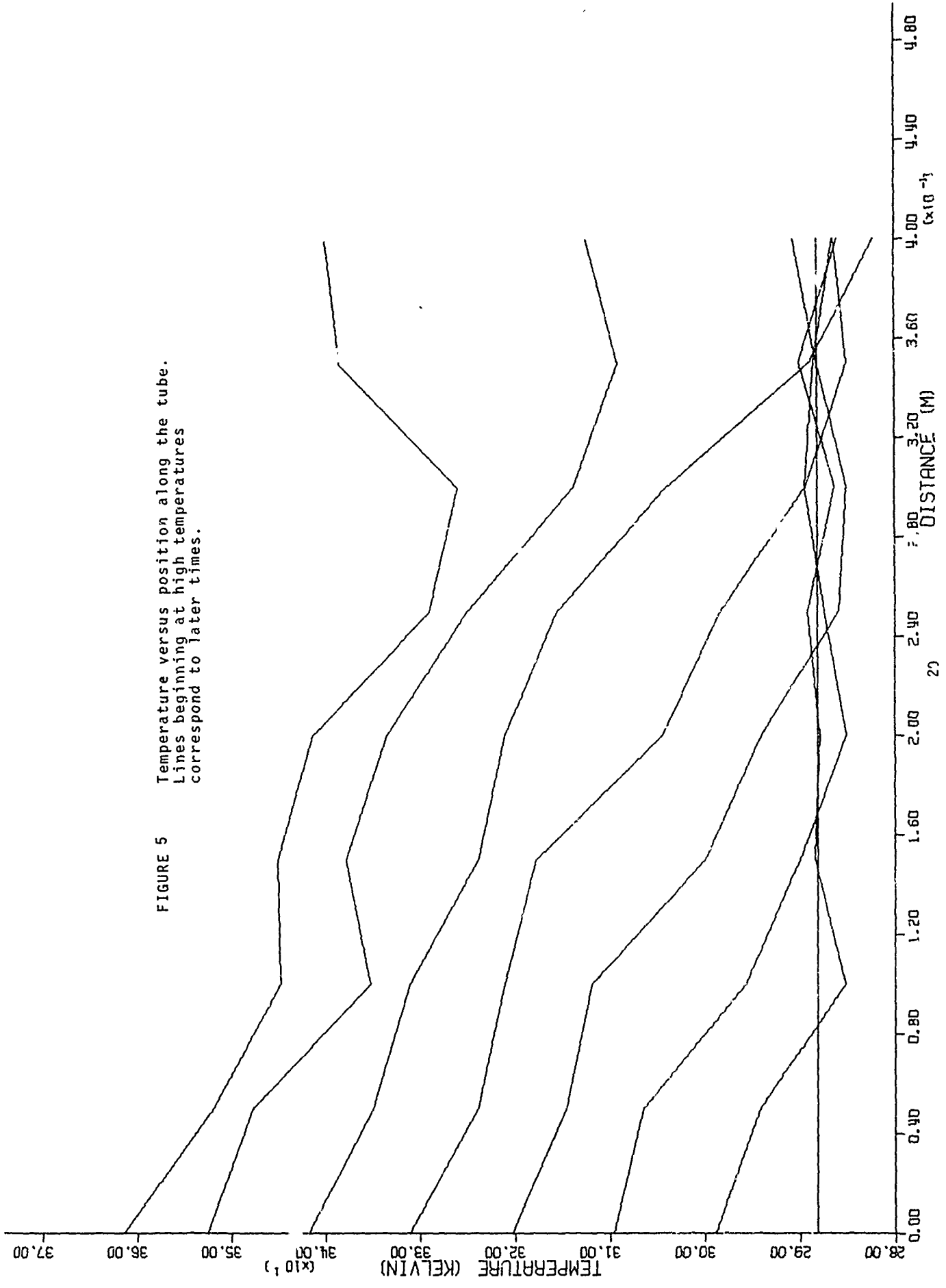

FIGURE 5 Temperature versus position along the tube.
Lines beginning at high temperatures
correspond to later times.



RECOMMENDATIONS FOR FUTURE WORK

To further explore this finite-element method and to extend its range of usefulness, the following should be undertaken:

1. Use a large analog or hybrid computer to solve the equations. Integrations would be more accurate than with a digital computer, and high rates of change may be possible.
2. Seek or develop other numerical techniques for solving the simultaneous equations.
3. Use a digital computer with accuracy greater than sixteen significant figures so that small time-steps can be taken with minimum round-off error.
4. Apply the method of characteristics and compare results with the finite-element technique.
5. Run experiments on the test apparatus developed and compare results with predictions.
6. Develop better methods to approximate the total mass, momentum, and energy contained in an element.
7. Develop a variational formulation of the problem.
8. Use higher degree polynomial distributions across each element.
9. Explore the use of distributions other than polynomial.

LITERATURE CITED

1. Bird, R.B., W.E. Stewart, and E.N. Lightfoot, Transport Phenomena, John Wiley & Sons, Inc., New York, (1960)
2. Langhaar, H.L., and S.C. Chu, "Piecewise Polynomials and the Partition Method for Ordinary Differential Equations," Developments in Theoretical and Applied Mechanics, Vol 8, (D. Frederick, ed.), Pergamom Press, New York, (1970)
3. Coddington, E.A., N. Levinson, Theory of Ordinary Differential Equations, McGraw-Hill Book Company, Inc., New York, (1955)
4. Gallagher, R.H., Y. Yamada, and J.T. Oden, editors, Recent Advances in Matrix Methods of Structural Analysis and Design, University of Alabama Press, (1971)
5. Proceedings of the Second Conference on Matrix Methods in Structural Mechanics, Air Force Flight Dynamics Laboratory, Wright-Patterson AFB, Ohio, AFFDL-TR-68-150, AD 703 685, (Dec. 1969)
6. Dean, D.V., "Finite Element Study of Acoustic Waves," Naval Post-graduate School, Monterey, California (Dec. 1970)
7. Masson, B.S., G.D. Massar, and T. McCarthy, "A Comparison of 1-D Unsteady Flow Field Methods, Volume I," Northrop Corporate Labs, Hawthorne, California, NCL-70-28, AD 881 225, (Feb. 1970)
8. Lee, E.S., et al, "Application of Quasilinearization to the Solution of Non-Linear Differential Equations," Kansas State Univ., Manhattan, AF AFOSR 463 66, AD 656 782, (Mar. 1967)
9. Nielsen, H.B., "A Finite Element Method for Calculating a Two-Dimensional Open Channel Flow," Basic Research - Progress Report 19, Coastal Engineering Laboratory, Hydraulic Laboratory, Technical University of Denmark, AD 862 313, (1969)

APPENDIX A

Computer Program with Assumed Linear Distributions

```

C      IMPLICIT REAL*8(A-H,O-Z)
      DEFINE FILE 9(5C,74,U,N)
      EXTERNAL FCT,OUTP
      DOUBLE PRECISION L,NUI
      DIMENSION PI(9),RHOI(9),NUI(9),TI(9),X(24),DERY(24)
      DIMENSION TIM1(4),PRES(4),TEMPE(4),TIM2(4),PRMT(3)
      COMMON/BLOCK1/PI,RHOI,TI,NUI
      COMMON/BLOX/TIM1,TIM2,PRES,TEMPE
      COMMON/BLOC/L,ALPHA,R,ODN,WDN,A
      COMMON/ASIT/NEP1,NE,NOUN,NCUP1,NEM1
      COMMON/OLDE/IUT
      COMMON/DOTE/XDOT1,XDOT2,ILNT1
      COMMON/PTS/IPTS
      COMMON/SSS/VDOT1,DISPL
      COMMON/GAS/HG
      COMMON/CCC/CGAM
      COMMON/BBB/DERY
      COMMON/INITT/ICAMP
      DISPL=0.000
      VDOT1=0.000
      IPTS=C
      ILNT1=1
      ICAMP=3
      XDOT1=0.000
      XDOT2=0.000
      IUT=C
      NAMELIST/INPT1/NE,A,ALPHA,R,DELT,NITER,WDN,QDN,L
      READ (5,INPT1)
      PRINT 11,NE,A,ALPHA,R,DELT,NITER,WDN,QDN,L
11  FORMAT(5X,'NE=',I3,5X,'A=',D15.8,5X,'ALPHA=',
1F10.5,/,5X,'R=',F10.5,5X,'DELT=',D15.8,5X,
2 'NITER=',I5,/,5X,'WDN=',F10.5,5X,'QDN=',F10.5,5X,'L=',F10.8,/)
      READ 1,PIQ,RHOIC,XUIO,TIO
      READ 501,NTIM,((TIM1(I),PRES(I)),I=1,NTIM)
1  FORMAT(8F10.5)
      READ 502,NTIM,((TIM2(I),TEMPE(I)),I=1,NTIM)
501 FORMAT(I5,/, (8E10.5))
502 FORMAT(I5,/, (8F10.5))
C      HG=2.0*3.14*DSQRT(7.91729D-6)*418.6/(.002*DSQRT(3.14D0))
C      HG=-HG
      HG=0.000
      CGAM=ALPHA/(ALPHA - R)
      PRINT 779,HG
779 FORMAT(' HG=',D12.5)
      NEP1=NE + 1
      DO 500 I=1,NEP1
      PI(I)=PIC
      NUI(I)=XUIO

```

G LEVEL 20

MAIN

DATE = 72101

11/17/00

```

      TI(1)=TIC
500 RHOI(1)=PIC/(R*TIC)
      NOUN=3*NE
      NOUP1=NOUN + 1
      NEM1=NE - 1
C NEW BOUNDARY CONDITIONS
C   TEMPORARY
C   READ 1,PI
C   READ 1, RHOI
C   READ 1,NUI
C   READ 1, TI
C   TEMPORARY
      X(1)=NUI(1)
      X(NOUN - 1) =RHOI(NEP1)
      X(NOUN)=TI(NEP1)
      IF(NE.EQ.1) GO TO 51
      DO 50 I=2,NE
      ITE=3*I
      X(ITE - 4)=RHOI(I)
      X(ITE - 3) =NUI(I)
50 X(ITE - 2)=TI(I)
      DO 50 I=2,NEP1
      ITE=3*I
      X(ITE - 5)=RHOI(I)
      X(ITE - 4)=NUI(I)
C 50 X(ITE - 3)=TI(I)
C NEW BOUNDARY CONDITIONS
51 READ 1,PRMT
      CALL RUNGE(PRMT,X,DERV,NCLN,FCT,OUTP)
C   I=1
C   WRITE (9'I)PI
C   I=2
C   WRITE (9'I)RHOI
C   I=3
C   WRITE(9'I)NUI
C   I=4
C   WRITE(9'I)TI
      PRINT 522,IPTS
522 FORMAT(' IPTS=',I3)
      CALL EXIT
      END
```

```

SUBROUTINE OUTP(T,X,DERY,NDIM,PRMT)
IMPLICIT REAL*8(A-H,O-Z)
DOUBLE PRECISION NUI,L
DIMENSION X(24),DERY(24),PRMT(3)
DIMENSION PI(9),RHOI(9),NUI(9),TI(9)
COMMON/ASIT/NEP1,NE,NCUN,NOUP1,NEM1
COMMON/BLOC/L,ALPHA,R,QDN,WDN,A
COMMON/BLOCK1/PI,RHOI,TI,NUI
COMMON/OLDE/IUT
COMMON/PTS/IPTS
COMMON/SSS/VDOT1,DISPL
IF(MOD(IUT,5).NE.0) GO TO 401
NUI(1)=X(1)
TI(NEP1)=X(NCUN)
C NEW BOUNDARY CONDITIONS
RHOI(NEP1)=X(NCUN - 1)
C FOR INTEGRATING END VELOCITY
STORE=PI(NEP1)
PI(NEP1)=R*RHOI(NEP1)*TI(NEP1)
VDOTS=VDOT1
C IF(T.GT.1.0D-3)VDOT1=VDOT1 + PRMT(3)*((PI(NEP1) + STORE)/2.DO
C 1 - 101000.DD)*7.91729D-2
C DISPL=DISPL + PRMT(3)*(VDOTS + VDOT1)/2.
C FOR INTEGRATING END VELOCITY
IF(NE.EQ.1) GO TO 61
DO 54 I=2,NE
ITE=3*I
RHOI(I)=X(ITE - 4)
NUI(I)=X(ITE - 3)
TI(I)=X(ITE - 2)
54 PI(I)=R*RHOI(I)*TI(I)
C DO 54 I=2,NEP1
C ITE=3*I
C RHOI(I)=X(ITE - 5)
C NUI(I)=X(ITE - 4)
C TI(I)=X(ITE - 3)
C 54 PI(I)=R*RHOI(I)*TI(I)
C NEW BOUNDARY CONDITIONS
61 PRINT9,T,L,DISPL,QDN,WDN
9 FORMAT(' T= ',F12.8,' L= ',F12.8,' DISPL= ',D12.5,
1 ' QDN= ',D12.5,' WDN= ',D12.5,/)
IPTS=IPTS + 1
C IF(IPTS.GT.50) GO TO 709
C WRITE(9,IPTS)T,PI,RHOI,NUI,TI
709 PRINT 3
3 FORMAT(' NODE',5X,' PRESS. DIST.',4X,' DENSITY DIST.',
1 5X,' VELOC. DIST.',6X,' TEMP. DIST.',/,13X,
2 'NT/M**2',11X,'KG/M**3',12X,'M/SEC',13X,'KELVIN')

```

G LEVEL 20

OUTP

DATE = 72101

11/17/00

```
DO 4 I=1,NEP1
  J=I - 1
  4 PRINT 5,J,PI(I),RHOI(I),NUI(I),TI(I)
  5 FORMAT(15,3X,F15.1,3X,F15.9,2(3X,F15.5),/)
401 IUT=IUT + 1
  RETURN
END
```

```

FUNCTION
1 FS(I,J,RHO1,NU1,T1,RHO2,NU2,T2)
  IMPLICIT REAL*8(A-H,C-Z)
  DOUBLE PRECISION NU1,NU2,L
    COMMON/BLOC/L,ALPHA,R,QDN,WDN,A
  COMMON/DOTE/XDOT1,XDOT2,ILNT1
  GO TO (1,2,3),I
  1 GO TO (11,12,13,14,15,16,17),J
  2 GO TO (21,22,23,24,25,26,27),J
  3 GO TO (31,32,33,34,35,36,37),J
11 FS=1.DC*L
  RETURN
12 FS=0.000
  RETURN
13 FS=0.C00
  RETURN
14 FS=1.DC*L
  RETURN
15 FS=0.C00
  RETURN
16 FS=0.C00
  RETURN
17 FS=2.*(RHO1*NU1 - RHO2*NU2
1- XDOT2*RHO2 + XDOT1*RHO1)
  RETURN
21 FS=(4.*NU1 + 2.*NU2)*L
  RETURN
22 FS=(4.*RHO1+ 2.*RHO2)*L
  RETURN
23 FS=0.C00
  RETURN
24 FS=(4.*NU2+ 2.*NU1)*L
  RETURN
25 FS=(2.*RHO1+ 4.*RHO2)*L
  RETURN
26 FS=0.C00
  RETURN
27 FS= -12.*(RHO2*NU2**2 - RHO1*NU1**2 + R*RHO2*T2 - R*RHO1*T1)
1 -(XDOT2*NU2*RHO2 - XDOT1*NU1*RHO1)*12.
  RETURN
31 FS=(NU1*NU1/8.+ NU2*NU2/24. + NU1*NU2/12.
1 +(ALPHA - R)*(2.*T2 + 4.*T1)/12.)*L
  RETURN
32 FS=(NU1*(RHO1/4.+ RHO2/12.) + NU2*(RHO1/12.+ RHO2/12.))*L
  RETURN
33 FS=((ALPHA- R)*(4.*RHO1 + 2.*RHO2)/12.)*L
  RETURN
34 FS=(NU1*NU1/24.+ NU2*NU2/8. + NU1*NU2/12.

```

G LEVEL 20

FS

DATE = 72101

11/17/00

```
1 +(ALPHA - R)*(4.*T2 + 2.*T1)/12.)*L
RETURN
35 FS=(NU2*(RH01/12.+ RH02/4.) + NU1*(RHC1/12.+ RH02/12.))*L
RETURN
36 FS=((ALPHA- R)*(2.*RH01 + 4.*RHC2)/12.)*L
RETURN
37 FS=(ALPHA*(RH01*NU1*T1 - RH02*NU2*T2)
1 + RH01*NU1**3/2. - RH02*NU2**3/2.) +(QDN - WDN)/A
2 - (XDOT2*RH02*(NU2*NU2/2. +(ALPHA - R)*T2)
3 - XDOT1*RH01*(NU1*NU1/2. + (ALPHA - R)*T1))
RETURN
END
```

G LEVEL 20

GAUSSE

DATE = 72101

11/17/00

```
SUBROUTINE GAUSSE (X,N)
IMPLICIT REAL*8(A-H,O-Z)
COMMON/ASTHT/ A
C   USES GAUSS ELIMINATION METHOD TO FIND SOLUTION TO SYSTEM OF EQUATIONS
DIMENSION X(24),A(24,25)
NM1=N - 1
NP1=N + 1
DO 1 K=1,NM1
C   FIND FIRST ROW WITH A BIG ENOUGH ELEMENT
KP5=K + 5
DO 100 II=K,KP5
IF( DABS(A(II,K)).GT. 1.00-30) GO TO 101
100 CONTINUE
PRINT 99
99 FORMAT( ' ALL ELEMENTS ARE PRACTICALLY ZERO IN MATINV' )
CALL EXIT
101 IF (II.EQ.K) GO TO 103
C   MAKE ROW INTERCHANGE
KP7=KP5
NEND= MIN0(KP7,NP1)
DO 104 JJ=K,NEND
B=A(K,JJ)
A(K,JJ)=A(II,JJ)
A(II,JJ)=B
104 CONTINUE
IF( NEND.EQ.NP1) GO TO 103
B=A(K,NP1 )
A(K,NP1 )=A(II,NP1 )
A(II,NP1 )=B
C   INTERCHANGE COMPLETED
103 B=A(K,K)
DO 2 J=K,NEND
A(K,J)=A(K,J)/B
2 CONTINUE
IF (NEND.EQ.NP1) GO TO 106
A(K,NP1 )=A(K,NP1 )/B
106 KP1= K+1
NSTOP=KP1 + 3 - MOD(KP1,3)
IF(NSTOP .GT. N) NSTOP=N
DO 1 I=KP1,NSTOP
B=A(I,K)
DO 17 J=K ,NEND
17 A(I,J)=A(I,J) - B*A(K,J)
IF (NEND.EQ.NP1) GO TO 1
A(I,NP1)=A(I,NP1) - B*A(K,NP1)
1 CONTINUE
107 X(N)=A(N,NP1)/A(N,N)
DO 3 K=1,NM1
```

G LEVEL 20

GAUSSE

DATE = 72101

11/17/00

```
KP1= N - K + 1
X(N-K)=A(N - K, NP1)
NSTOP= KP1 + MOD(K,3) + 3
NSTOP= MINC(NSTOP,N)
DO 3 J=KP1,NSTOP
3 X(N-K)=X(N-K) - A(N - K, J)*X(J)
RETURN
END
```

G LEVEL 20

UPDATE

DATE = 72101

11/17/60

```
SUBROUTINE UPDATE(T,X,Y,F,FD)
  IMPLICIT REAL*8(A-H,O-Z)
  DIMENSION X(4),Y(4)
  DO 1 I=1,4
  IF(T .LE. X(I)) GO TO 2
1 CONTINUE
  I=4
2 I= 1 - 1
  IF(I.EQ.C) I=1
  F=      Y(I) + (T - X(I))*(Y(I + 1) - Y(I))/(X(I + 1) - X(I))
  FD=(Y(I + 1) - Y(I))/(X(I + 1) - X(I))
  RETURN
  END
```

```

SUBROUTINE FCT(T,X,XDOT)
IMPLICIT REAL*8(A-H,O-Z)
DIMENSION X(24),XDOT(24),PI(9),RHCI(9),NUI(9),TI(9)
DIMENSION A(24,25)
DIMENSION DERY(24)
DOUBLE PRECISION NUI,L
COMMON/BLOCK1/PI,RHCI,TI,NUI
1/BLOX/TIM1,TIM2,PRES,TEMPE
COMMON/BLOC/L:ALPHA,R,QDN,hDN,DUM1
2/ASIT/NEP1,NE,NOUN,NOUP1,NEM1
COMMON/DOTE/XDOT1,XDOT2,ILNT1
DIMENSION PRES(4),TIM1(4),TEMPE(4),TIM2(4)
COMMON /ASTHT/A
COMMON/SSS/VDOT1,DISPL
COMMON/GAS/HG
COMMON/CCC/CGAM
COMMON/BBB/DERY
COMMON/INITT/ICAMP
ICAMP=ICAMP + 1
N=NOUN
C DO 8888 I=1,N
C DO 8888 J=1,NOUP1
C8888 A(I,J)=0.CDC
C NEW BOUNDARY CONDITIONS
VM=0.CDC
C NEW BOUNDARY CONDITIONS
C FOR TRAVELING WAVE
C IF ILNT1 IS GREATER THAN ZERO THEN NO TRAVELING WAVE
C IF(ILNT1.GT.0) GO TO 102
XNF=NE
XDOT1=0.CDC
XDOT2=376.948D0
L=T*XDOT1/2/XNF *.005
IF(L.GE..05D0) GO TO 101
GO TO 102
101 XDOT2=0.CDC
ILNT1=1
C FOR A TRAVELING WAVE
102 CALL UPDATE(T,TIM1,PRES,PI(1),PD)
CALL UPDATE(T,TIM2,TEMPE,TI(1),TD)
C THESE EQUATIONS ARE FOR THE ASSUMPTION THAT THE FLOW ON THE TOP ELEMENT
C IS ISENTROPIC
C RATI=CGAM
C PI(1)=(TI(1)/288.16)**(RATI/(RATI - 1.))*10100C.
C PD=10100C.*RATI*(TI(1)/288.16)**(1./(RATI - 1.))
C 1 *TD/(288.16*(RATI - 1.))
C THESE EQUATIONS ARE FOR THE ASSUMPTION THAT THE FLOW ON THE TOP ELEMENT
C IS ISENTROPIC

```

```

      RHOI(1)=PI(1)/(R*TI(1))
      RHOD=PD/(R*TI(1)) - PI(1)*TD/(R*TI(1)*TI(1))
C     NEW BOUNDARY CONDITIONS
C     NUI(1)=266011.3DC*T
      NUI(1)=X(1)
      YI(NEP1)=X(N)
C     COMPUTATION FOR SHOCK
C     SHOCK INSERT A
C     COMPUTATION FOR SHOCK
542  VDOT=0.0DC
C     QDN=L*HG*((TI(1) + TI(2))/2. - 288.16)
C     IF(QDN.GT.G.0DC) QDN=0.0DC
C     GO TO 775
C     IF (T.LT.1.D-3) GO TO 775
C     NUI(NEP1)=VDOT1
C     VDOT=7.9172917D-2*PI(NEP1)
775  RHOI(NEP1)=X(N - 1)
      IF(NE.EQ.1)VM=VDOT
      IF(NE.EQ.1) GO TO 27
      DO 11 I=2,NE
        ITE=3*I
        RHOI(I)=X(ITE - 4)
        NUI(I)=X(ITE - 3)
11   TI(I)=X(ITE - 2)
      DO 11 I=2,NEP1
        ITE=3*I
        RHOI(I)=X(ITE - 5)
        NUI(I)=X(ITE - 4)
11   TI(I)=X(ITE - 3)
C     SET UP FIRST 3 EQUATIONS
27  DO 1 I=1,3
      JJ=1
      DO 2 J=4,6
C     JJ=J - 3
      IF(NE.NE.1)JJ=J - 2
      IF(NE.EQ.1 .AND. J.EQ.5) GO TO 2
      IF(NE.EQ.1) JJ=JJ+ 1
      A(I,JJ) =FS(I,J,RHOI(1),NUI(1),TI(1),RHOI(2),NUI(2),TI(2))
2   CONTINUE
C   IF(NE.EQ.1) GO TO 771
      NEND=MINO(8,N)
      DO 3 JP=5,NEND
3   A(I,JP)=0.0DC
C   NEW BOUNDARY CONDITIONS
771  A(I,NOUP1)=FS(I,7,RHOI(1),NUI(1),TI(1),RHOI(2),NUI(2),TI(2))
      1 - RHOD*FS(I,1,RHOI(1),NUI(1),TI(1),RHOI(2),NUI(2),TI(2))
      2 - TD*FS(I,3,RHOI(1),NUI(1),TI(1),RHOI(2),NUI(2),TI(2))
      3 - VM*FS(I,2,RHOI(1),NUI(1),TI(1),RHOI(2),NUI(2),TI(2))

```

G LEVEL 20

FCT

DATE = 72101

11/17/00

```
      A(I,1)=FS(I,2,RHOI(1),NUI(1),TI(1),RHOI(2),NUI(2),TI(2))
1 CONTINUE
C   FOR A SHOCK CONDITION
C   INSERT B
C   FOR A SHOCK CONDITION
C   FOR A TRAVELING WAVE
C   XDOT1=XDOT2
C   FOR A TRAVELING WAVE
C   FIRST 3 EQUATIONS ARE SET UP
4000 IF(NE.EQ.1) GO TO 700
      IF(NE.EQ.2) GO TO 600
      DO 50 II=2,NEM1
C     COMPUTATION FOR SHOCK
C     INSERT C
C END COMPUTATION FOR SHOCK
      668 QDN=L*HG*((TI(II) + TI(II + 1))/2. - 288.16)
      IF(QDN.GT.0.000) QDN=0.000
      ITE=3*(II - 1)
C     ITE1=3*(II - 2)
      ITE1=3*(II - 2) + 1
C NEW BOUNDARY CONDITIONS
      DO 51 I=1,3
      DO 52 J=1,6
      52 A(ITE + I,ITE1 + J)=FS(I,J,RHOI(II),NUI(II),TI(II),
      1 RHOI(II + 1),NUI(II + 1),TI(II + 1))
      VEND=4
      IF(II.EQ.NEM1) NEND=3
      DO 53 J=1,NEND
      53 A(ITE + I,ITE1 + 6 + J)=0.000
      51 A(ITE + I,NOUP1)=FS(I,7,RHOI(II),NUI(II),TI(II),
      1 RHOI(II + 1),NUI(II + 1),TI(II + 1))
C     COMPUTATION FOR SHOCK
C     INSERT D
C     COMPUTATION FOR SHOCK
50 CONTINUE
C NEW BOUNDARY CONDITIONS
C GO TO 700
C NEW BOUNDARY CONDITIONS
C THIS IS USED WHEN BOLT OR PISTON IS ALLOWED TO MOVE
C XSTORE=L
C XDQT2=NUI(NEP1)
C L=L + DISPL
C WDN=(PI(NEP1) - 101000.00)*DUM1*NUI(NEP1)
C THE ABOVE IS USED WHEN THE BOLT OR PISTON ARE ALLOWED TO MOVE.
C SET UP THE LAST EQUATION
C QDN= L*HG*((TI(NE) + TI(NEP1))/2. - 288.16)
C IF(QDN.GT.C.000) QDN=0.000
600 DO 60 I=1,3
```

```

      INT=C
      DO 61 J=1,6
C     NEW BOUNDARY CONDITIONS
C     IF(J.EQ.4) GO TO 61
C     IF(J.EQ.5) GO TO 61
C     NEW BOUNDARY CONDITIONS
      INT=INT + 1
      A(N - 3 + I,N - 5 + INT)=FS(I,J,RHOI(NE),NUI(NE),TI(NE),
      1 RHOI(NEP1),NUI(NEP1),TI(NEP1))
      61 CONTINUE
C     NEW BOUNDARY CONDITIONS
      A(N - 3 + I,NOUP1)=FS(I,7,RHOI(NE),NUI(NE),TI(NE),RHOI(NEP1),
      1 NUI(NEP1),TI(NEP1)) - VDCT*FS(I,5,RHOI(NE),NUI(NE),TI(NE),
      2 RHOI(NEP1),NUI(NEP1),TI(NEP1))
C     1 NUI(NEP1),TI(NEP1))
C     A(N - 3 + I,N)=A(N - 3 + I,N) + RHO2*FS(I,4,RHOI(NE),NUI(NE),
C     1 TI(NE),RHOI(NEP1),NUI(NEP1),TI(NEP1))
C     NEW BOUNDARY CONDITIONS
      60 CONTINUE
C     USED WHEN PISTON IS ALLOWED TO MOVE
C     XDGT2=C.CDO
C     L=XSTORE
C     WDN=0.C
C     USED WHEN PISTON IS ALLOWED TO MOVE
C     IF(MOD(ICAMP,4).NE.C) GO TO 700
C     DIMENSION STT(24,25)
C     DO 5050 I=1,N
C     DO 5050 J=1,NOUP1
C5050 STT(I,J)=A(I,J)
      700 CALL GAUSSE(XDOT,N)
C     IF(MOD(ICAMP,4).NE.C) GO TO 7000
C     DO 5051 I=1,N
C     DEV=0.CDO
C     DO 5052 K=1,N
C5052 DEV=DEV + STT(I,K)*XDGT(K)
C     ERROR=(DEV - STT(I,NOUP1))*100./DEV
C     PRINT 9040,DEV,ERROR,XDOT(I)
C9040 FORMAT(' LEFT=',D12.5,' ERROR=',D12.5,' XDOT(I) =',D12.5)
C5051 CONTINUE
      7000 CONTINUE
      RETURN
      END

```

G LEVFL 2'

RUNGE

DATE = 72101

11/17/CO

```

SUBROUTINE RUNGE(PRMT,X,DERY,N,FCT,CUTP)
IMPLICIT REAL*8(A-H,O-Z)
DIMENSION X(24),DERY(24),AK1(24),AK2(24),AK3(24),AK4(24),STORE(24)
1 ,PRMT(3) ,AK5(24),AK6(24)
T=PRMT(1)
DELT=PRMT(3)
SUM=DELT*.5DC
FINAL=PRMT(2)
1CCC CALL FCT(T,X,DERY)
CALL OUTP(T,X,DERY,N,PRMT )
IF(T.GE.FINAL) RETURN
DO 1 I=1,N
AK1(I)=DERY(I)*DELT
TEMP=X(I)
STORE(I)=TEMP
1 X(I)=TEMP + AK1(I)*.5DC
T=T + SUM
CALL FCT(T,X,DERY)
DO 3 I=1,N
AK2(I)=DELT*DERY(I)
3 X(I)=AK2(I)*.5DC + STORE(I)
CALL FCT(T,X,DERY)
DO 5 I=1,N
AK3(I)=DELT*DERY(I)
5 X(I)=STORE(I) + AK3(I)
T=T + SUM
CALL FCT(T,X,DERY)
DO 7 I=1,N
AK4(I)=DELT*DERY(I)
7 X(I)=STORE(I) + (AK1(I) + 2.00*(AK2(I) + AK3(I)) + AK4(I))*
1 .16666666666666667DC
GO TO 1CCC
END
```

APPENDIX B

Existence and Uniqueness Proof

Existence and Uniqueness Proof

Because of the difficulty in finding stable solutions of the simultaneous equations in this study, some work was done to establish existence and uniqueness of solution. The arguments presented below demonstrate that for a single element and for very specific end conditions, a closed interval exists about the initial time for which a unique solution is present. No attempt at generalizing the argument to n-elements and very general end conditions is made.

First, a general theorem from Reference 3 is used.

$$\text{Defn: } |x| = \sum_{i=1}^n |x_i|$$

where x is an n -dimensional vector.

Defn: $f(t,x)$ satisfies a Lipschitz condition on a domain D of a (t,x) space if and only if a $K > 0$ exists such that $|f(t,x_1) - f(t,x_2)| \leq K |x_1 - x_2|$ for each (t,x_1) and (t,x_2) in D .

Given:

$$(E) \quad \dot{x} = f(t,x)$$

$$x(\tau) = \xi$$

Thrm: Suppose $f \in (C, \text{Lip})$

(i.e., continuous in t and Lipschitz in x)

on the rectangle,

$$R: |t - \tau| \leq a, |x - \xi| \leq b \quad (a, b > 0)$$

and let $M = \max |f(t,x)| \quad (t,x) \in R$

then a unique solution exists $\psi \in C^1$ (C^1 is the set of all functions having one continuous derivative) of (E) on $|t - \tau| \leq \alpha$ such that

$$\dot{\psi}(t) = f(t,\psi)$$

$$\psi(\tau) = \xi$$

and

$$\alpha = \min\left(a, \frac{b}{M}\right)$$

For the domain, D , of the existence, one can show that if the partials with respect to x are continuous for each $(t,x) \in D$, then a Lipschitz condition holds in D .

One then applies this condition rather than show a Lipschitz condition directly.

Let

$$\frac{\partial f}{\partial x} = \begin{pmatrix} \frac{\partial f_1}{\partial x_1} & \cdots & \frac{\partial f_1}{\partial x_n} \\ \vdots & & \vdots \\ \frac{\partial f_n}{\partial x_1} & \cdots & \frac{\partial f_n}{\partial x_n} \end{pmatrix}$$

By the mean value theorem, if $\frac{\partial f}{\partial x}$ exists componentwise for each

$$x^* \in B \triangleq \{x' : x' = (1 - \lambda)\tilde{x} + \lambda x, 0 \leq \lambda \leq 1\},$$

an $x^* \in B$ exists such that

$$f(t,x) - f(t,\tilde{x}) = \left(\frac{\partial f}{\partial x}\right)_{x=x^*} (x - \tilde{x})$$

NOTE: The domain of consideration in the existence theorem is convex; therefore, one can apply the mean value theorem.

Let

$$M^* = \max_{i,j} \max_{(t,x) \in D} \left| \frac{\partial f_j}{\partial x_i} \right|$$

Since $\frac{\partial f_j}{\partial x_i}$ is continuous, $\left| \frac{\partial f_j}{\partial x_i} \right|$ is implied to be continuous; and D is closed and bounded. Therefore, M^* exists.

$$\begin{aligned} |f(t,x) - f(t,\tilde{x})| &= \sum_{j=1}^n |f_j(t,x) - f_j(t,\tilde{x})| \\ &= \sum_{j=1}^n \left| \sum_{i=1}^n \left(\frac{\partial f_j}{\partial x_i}\right)_{x=x^*} (x_i - \tilde{x}_i) \right| \end{aligned}$$

$$\leq \sum_{j=1}^n \sum_{i=1}^n \left| \left(\frac{\partial f_j}{\partial x_i} \right)_{x=x^*} \right| |x_i - \tilde{x}_i|$$

$$\leq n M^* \sum_{i=1}^n |x_i - \tilde{x}_i| = n M^* |x - \tilde{x}|$$

A K , namely $K = n M^*$, exists.

Now, consider the gas equations, and put them in a form so that the previous results can be applied.

The end conditions are

$$\rho_1 = a_1 + b_1 t, \quad T_1 = c_1, \quad v_2 = 0$$

a_1, b_1, c_1 are constants.

After substitution, the differential equations to be solved are

$$(1) \quad \dot{\rho}_2 = -b_1 + \frac{2}{L} (a_1 + b_1 t) v_1$$

$$(2) \quad \dot{v}_1 = - \left\{ 2b_1 v_1 + \frac{4}{L} (a_1 + b_1 t) v_1^2 \right. \\ \left. + \frac{12}{L} [-(a_1 + b_1 t) v_1^2 + R \rho_2 T_2 - R(a_1 + b_1 t) T_1] \right\} / (4\rho_1 + 2\rho_2)$$

$$(3) \quad \left[\frac{v_1^2}{24} + \frac{(\alpha - R)}{12} (4T_2 + 2T_1) \right] \dot{\rho}_2 + \left[\frac{\rho_1}{4} + \frac{\rho_2}{12} \right] v_1 \dot{v}_1 \\ + \left[\frac{(\alpha - R)}{12} (2\rho_1 + 4\rho_2) \right] \dot{T}_2 = - \left[\frac{v_1^2}{8} + \frac{(\alpha - R)}{12} (2T_2 + 4T_1) \right] b_1 \\ + \frac{1}{L} [\alpha \rho_1 v_1 T_1 + \frac{1}{2} \rho v_1^3]$$

By forward substitution, equations of the following form result:

$$\dot{\rho}_2 = F_1(t, \rho_2, v_1, T_2)$$

$$\dot{v}_1 = F_2(t, \rho_2, v_1, T_2)$$

$$\dot{T}_2 = F_3(t, \rho_2, v_1, T_2)$$

Initial conditions are

$$\rho_2(0) = \rho_{20}$$

$$v_1(0) = v_{10}$$

$$T_2(0) = T_{20}$$

The only points where the partials do not exist and are not continuous are at $\rho_2 = -2\rho_1$ and $\rho_1 = -2\rho_2$. Since F_1 , F_2 , and F_3 are continuous for all t , one can choose a $\delta > 0$ to be any value. Also,

$$\rho_2(0) \neq \frac{\rho_1(0)}{2} \text{ or } \rho_2(0) \neq -2\rho_1(0)$$

(The conditions above would be physically unrealistic)

which implies that a $b > 0$ exists such that $|\rho_2 - \rho_{20}| + |v_1 - v_{10}|$

+ $|T_2 - T_{20}| \leq b$ and the partials of F_1 , F_2 , and F_3 are finite.

Existence and uniqueness are present, at least on the interval, $[0, \alpha]$, where

$$\alpha = \min\left(a, \frac{b}{M}\right)$$

and $M = \max(|F_1| + |F_2| + |F_3|)$

M is determined on the domain:

$$|t| \leq a$$

$$|\rho_2 - \rho_{20}| + |v_1 - v_{10}| + |T_2 - T_{20}| \leq b$$

APPENDIX C

Analog Computer Block Diagram for a Single Element

DIFFERENTIAL ANALYSEZ BASIC DIAGRAM FOR ONE ELEMENT

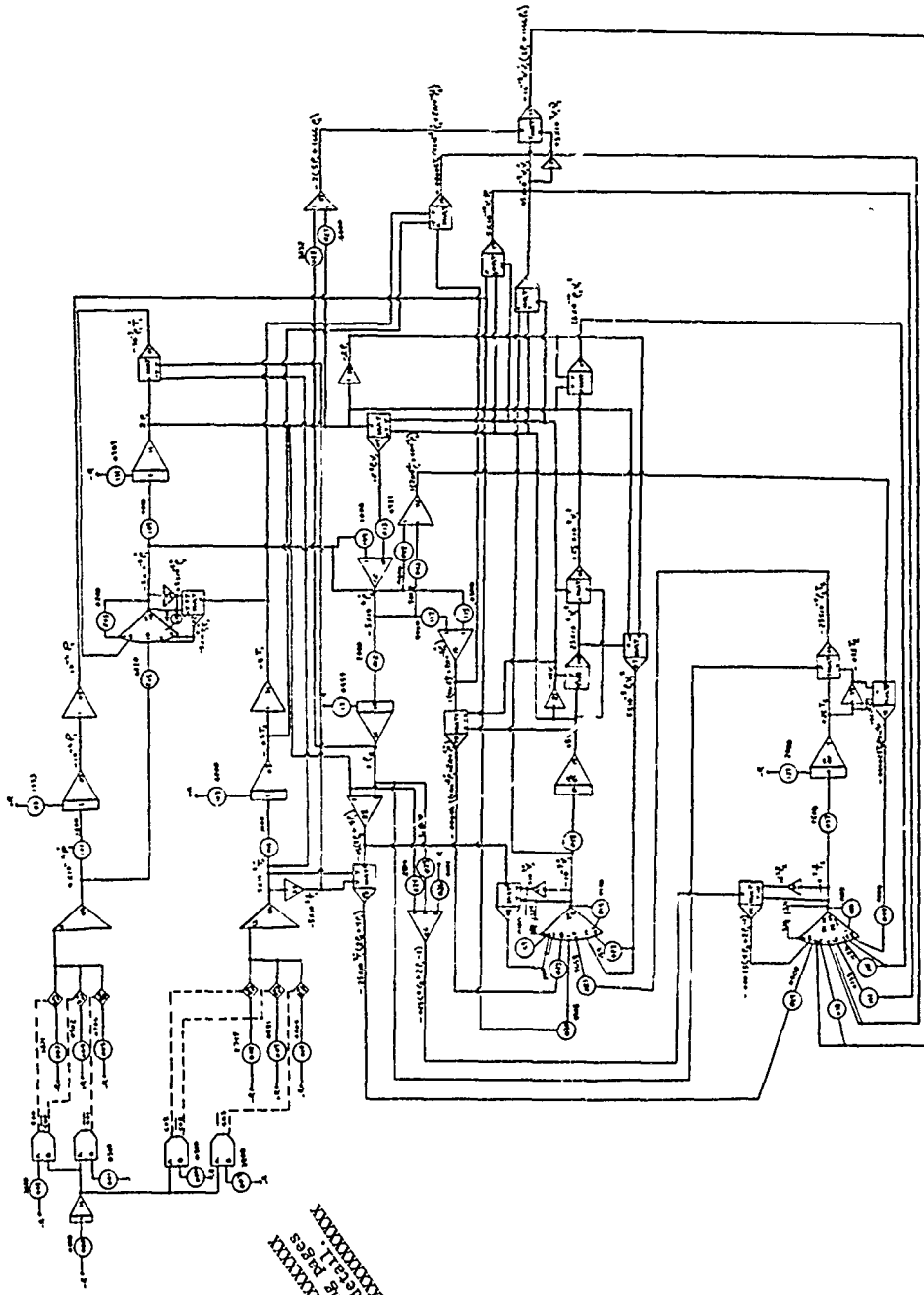

XXXXXXXXXXXXXXXXXXXX
See the following pages
XXXXXXXXXXXXXXXXXXXX

NOTE: 45.1
PAGE 41.0

45.2

Input
10 No. 72

45.1

DIFFERENTIAL ANALYZER BLOCK DIAGRAM FOR ONE ELEMENT

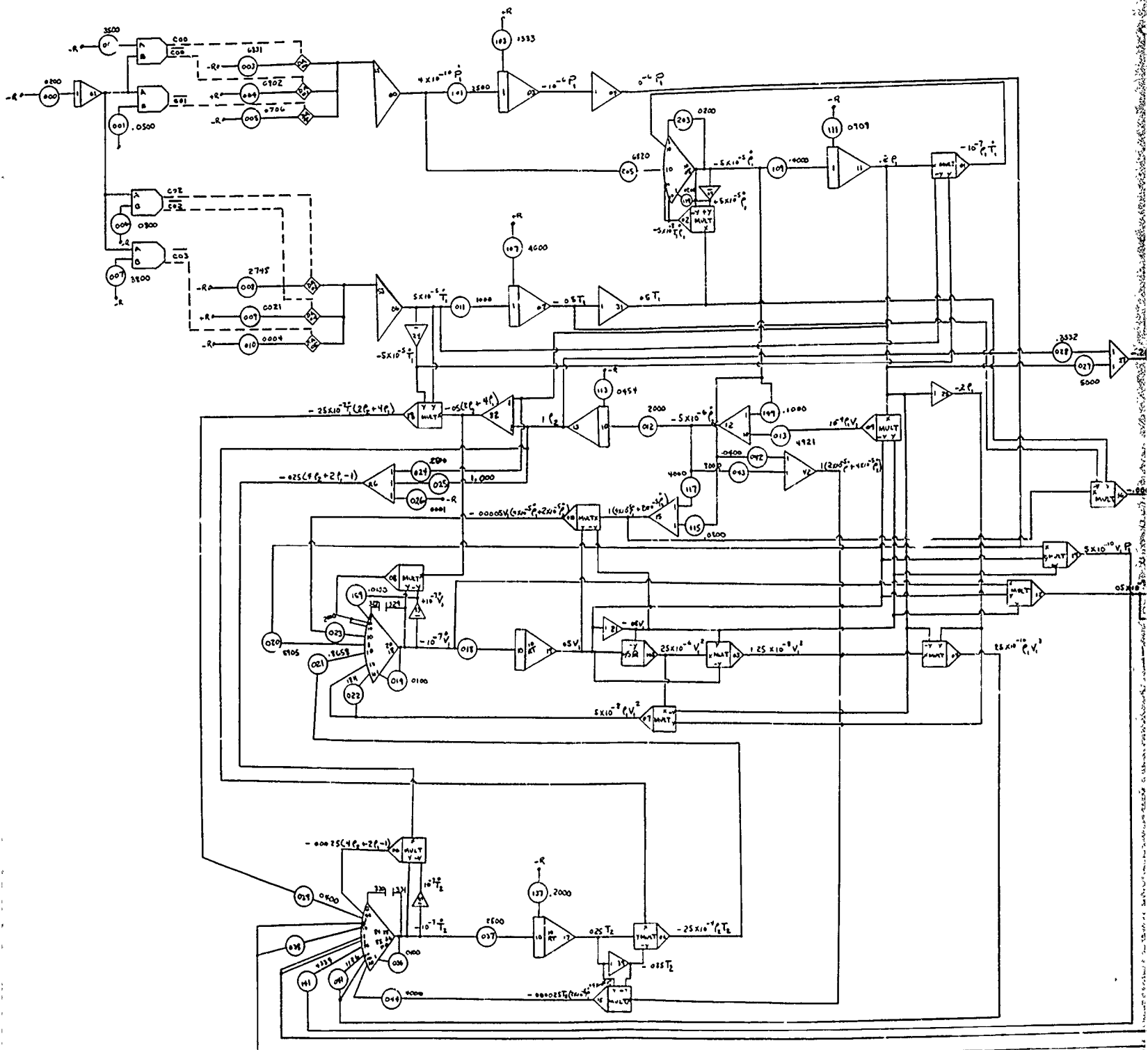

45.1

45.2

DIFFERENTIAL ANALYZER BLOCK DIAGRAM FOR ONE ELEMENT

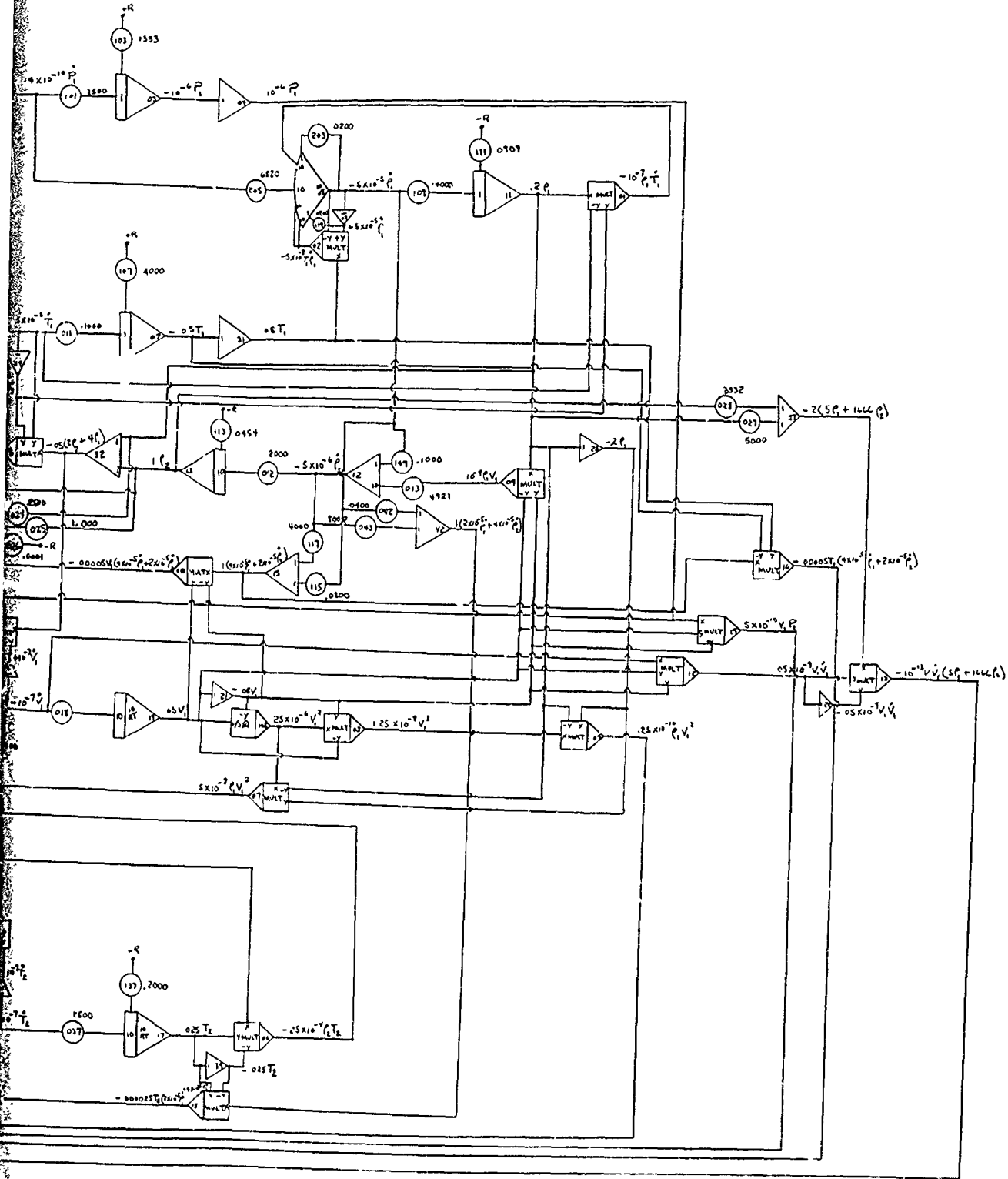

NOTE:
 $c = T \frac{d}{dt}$
 WHERE $\rho = 0.9$

45.2

APPENDIX D

Governing Equations with Assumed Parabolic Distributions

In the following discussion superscripts denote different functions and not derivatives. Define ρ for the first element by the following:

$$\rho^{(1)}(x) = \rho_1 + \left(\frac{\rho_2 - \rho_1}{L} - c_1 L\right)x + c_1 x^2$$

Note that:

$$\rho^{(1)}(0) = \rho_1 \text{ and } \rho^{(1)}(L) = \rho_2$$

Rather than letting $c_1 = 0$ and having a straight-line approximation for the density on the first element, one may choose c_1 such that, if one extended the definition of ρ over the second element, then ρ would have the value ρ_3 at $x = 2L$ (i.e., $\rho^{(1)}(2L) = \rho_3$).

The appropriate value for c_1 is given by:

$$c_1 = (\rho_3 - 2\rho_2 + \rho_1) / 2L^2$$

Choosing c_1 as shown above yields better results for the derivative between elements (1) and (2) since the curve is now bent in the proper direction. For the remaining elements, the derivatives will be forced to be continuous at the interface. Also for the remaining elements one obtains the coefficients in terms of the previously calculated values of b_K .

For the K th element

$$\rho^{(K)}(x) = a_K + b_K x + c_K x^2$$

Requiring the derivatives to be equal at the interface:

$$\rho^{(K)}(0) = b_K = 2c_{K-1} L + b_{K-1} = \rho^{(K-1)}(L)$$

Requiring the functions to be continuous:

$$\rho^{(K)}(0) = a_K = \rho_K$$

$$\rho^{(K-1)}(L) = \rho_{K-1} + b_{K-1} L + c_{K-1} L^2 = \rho_K$$

Solving for a_K , b_K and c_K one finds:

$$a_K = \rho_K$$

$$b_K = -b_{K-1} + 2 \frac{(\rho_K - \rho_{K-1})}{L}$$

$$c_K = \frac{b_{K-1}}{L} + \frac{(\rho_{K+1} - 3\rho_K + 2\rho_{K-1})}{L^2}$$

A similar analysis for the velocity gives:

$$v^{(1)}(x) = \zeta_1 + \eta_1 x + \xi_1 x^2$$

where

$$\zeta_1 = v_1$$

$$\eta_1 = \frac{-v_3 + 4v_2 - 3v_1}{2L}$$

$$\xi_1 = \frac{v_3 - 2v_2 + v_1}{2L^2}$$

and

$$v^{(K)}(x) = \zeta_K + \eta_K x + \xi_K x^2$$

where

$$\zeta_K = v_K$$

$$\eta_K = -\eta_{K-1} + 2 \frac{(v_K - v_{K-1})}{L}$$

$$\xi_K = \frac{\eta_{K-1}}{L} + \frac{(v_{K+1} - 3v_K + 2v_{K-1})}{L^2}$$

Also, the temperature distribution is handled in the same way:

$$T^{(1)}(x) = \delta_1 + \beta_1 x + \gamma_1 x^2$$

where

$$\delta_1 = T_1$$

$$\beta_1 = \frac{-T_3 + 4T_2 - 3T_1}{2L}$$

$$\gamma_1 = \frac{T_3 - 2T_2 + T_1}{2L^2}$$

and

$$T^{(K)}(x) = \delta_K + \beta_K x + \gamma_K x^2$$

where

$$\delta_K = T_K$$

$$\beta_K = -\beta_{K-1} + 2 \frac{(T_K - T_{K-1})}{L}$$

$$\gamma_K = \frac{\beta_{K-1}}{L} + \frac{(T_{K+1} - 3T_K + 2T_{K-1})}{L^2}$$

One now applies the state, momentum, continuity, and energy equations to obtain relationships for the unknown pressure, temperature, velocity, and density at each node or interface point.

$M_{TOT}^{(K)}$ - Total Mass for Kth element

$P_{TOT}^{(K)}$ - Total Momentum for Kth element

$U_{TOT}^{(K)}$ - Total Potential energy for Kth element

$K_{TOT}^{(K)}$ - Total Kinetic energy for Kth element

Continuity equation is:

$$\frac{d M_{TOT}^{(K)}}{dt} = A (\rho_K v_K - \rho_{K+1} v_{K+1})$$

where

$$M_{TOT}^{(K)} = \int_0^L \rho^{(K)}(x) A dx$$

substituting the function $\rho^{(K)}(x)$ and taking time derivatives, one finds:

$$\dot{a}_K L + \dot{b}_K \frac{L^2}{2} + \dot{c}_K \frac{L^3}{3} = \rho_K v_K - \rho_{K+1} v_{K+1}$$

From previous work, a_K , b_K , and c_K are known as functions of $\rho_1, \rho_2 \dots \rho_K$ except for $K = 1$, which is a function of ρ_{K+1} also.

One obtains n differential equations, i.e., an equation for each element. Similarly, one obtains n equations from the momentum and energy relationships.

Momentum equation is:

$$\frac{d P_{TOT}^{(K)}}{dt} = -A (\rho_{K+1} v_{K+1}^2 - \rho_K v_K^2 + P_{K+1} - P_K)$$

where

$$p^{(K)}_{TOT} = A \int_0^L v^K(x) \rho^K(x) dx$$

P_K is eliminated by using the state equation:

$$P_K = R\rho_K T_K$$

After expanding and integrating

$$\begin{aligned} & \dot{a}_K \left(\zeta_K L + \eta_K \frac{L^2}{2} + \xi_K \frac{L^3}{3} \right) \\ & + \dot{b}_K \left(\zeta_K \frac{L^2}{2} + \eta_K \frac{L^3}{3} + \xi_K \frac{L^4}{4} \right) + \\ & \dot{c}_K \left(\zeta_K \frac{L^3}{3} + \eta_K \frac{L^4}{4} + \xi_K \frac{L^5}{5} \right) + \\ & \dot{\zeta}_K \left(a_K L + b_K \frac{L^2}{2} + c_K \frac{L^3}{3} \right) + \\ & \dot{\eta}_K \left(a_K \frac{L^2}{2} + b_K \frac{L^3}{3} + c_K \frac{L^4}{4} \right) + \\ & \dot{\xi}_K \left(a_K \frac{L^3}{3} + b_K \frac{L^4}{4} + c_K \frac{L^5}{5} \right) = \\ & - \left[\rho_{K+1} v_{K+1}^2 - \rho_K v_K^2 + R\rho_{K+1} T_{K+1} - R\rho_K T_K \right] \end{aligned}$$

The energy equation is:

$$\frac{d \left(U^{(K)}_{TOT} + K^{(K)}_{TOT} \right)}{dt} = A \alpha \left(\rho_K v_K T_K - \rho_{K+1} v_{K+1} T_{K+1} \right)$$

$$+ \frac{1}{2} A (\rho_K v_K^3 - \rho_{K+1} v_{K+1}^3) + \dot{Q}^{(K)} - \dot{W}^{(K)}$$

where

$$K^{(K)}_{TOT} = \frac{A}{2} \int_0^L \rho^{(K)}(x) (v^{(K)}(x))^2 dx$$

$$U^{(K)}_{TOT} = A (\alpha-R) \int_0^L \rho^{(K)}(x) T^{(K)}(x) dx$$

$\dot{Q}^{(K)}$ - rate heat enters an element

$\dot{W}^{(K)}$ - work being done within an element

$$a_K [(\zeta_K^2 L + 2\zeta_K \eta_K \frac{L^2}{2} + (2\zeta_K \xi_K + \eta_K^2) \frac{L^3}{3} + 2\eta_K \xi_K \frac{L^4}{4}$$

$$+ \xi_K^2 \frac{L^5}{5})/2 + (\alpha-R) (L\delta_K + \beta_K \frac{L^2}{2} + \gamma_K \frac{L^3}{3})] +$$

$$b_K [(\zeta_K^2 \frac{L^2}{2} + 2\zeta_K \eta_K \frac{L^3}{3} + (2\zeta_K \xi_K + \eta_K^2) \frac{L^4}{4}$$

$$+ 2\eta_K \xi_K \frac{L^5}{5} + \xi_K^2 \frac{L^6}{6})/2 + (\alpha-R) (\delta_K \frac{L^2}{2} + \beta_K \frac{L^3}{3} + \gamma_K \frac{L^4}{4})]$$

$$+ \dot{c}_K [(\zeta_K^2 \frac{L^3}{3} + 2\zeta_K \eta_K \frac{L^4}{4} + (2\zeta_K \xi_K + \eta_K^2) L^5/5$$

$$+ 2\eta_K \xi_K \frac{L^6}{6} + \xi_K^2 \frac{L^7}{7})/2 + (\alpha-R) (\delta_K \frac{L^3}{3} + \beta_K \frac{L^4}{4} + \gamma_K \frac{L^5}{5})]$$

$$+ \dot{\zeta}_K [\zeta_K a_K L + (\zeta_K b_K + \eta_K a_K) \frac{L^2}{2} + (\zeta_K c_K + \eta_K b_K + \xi_K a_K) \frac{L^3}{3}$$

$$+ (\eta_K c_K + \xi_K b_K) \frac{L^4}{4} + \xi_K c_K \frac{L^5}{5}]$$

$$\begin{aligned}
& + \dot{\eta}_K \left[\zeta_K a_K \frac{L^2}{2} + (\zeta_K b_K + \eta_K a_K) \frac{L^3}{3} + (\zeta_K c_K + \eta_K b_K \right. \\
& + \left. \xi_K a_K) \frac{L^4}{4} + (\eta_K c_K + \xi_K b_K) \frac{L^5}{5} + \xi_K c_K \frac{L^6}{6} \right] \\
& + \dot{\xi}_K \left[\zeta_K a_K \frac{L^3}{3} + (\zeta_K b_K + \eta_K a_K) \frac{L^4}{4} + (\zeta_K c_K + \eta_K b_K \right. \\
& + \left. \xi_K a_K) \frac{L^5}{5} + (\eta_K c_K + \xi_K b_K) \frac{L^6}{6} + \xi_K c_K \frac{L^7}{7} \right] + \\
& \delta_K \left[(\alpha - R) \left(a_K L + b_K \frac{L^2}{2} + c_K \frac{L^3}{3} \right) \right] \\
& + \dot{\delta}_K \left[(\alpha - R) \left(a_K \frac{L^2}{2} + b_K \frac{L^3}{3} + c_K \frac{L^4}{4} \right) \right] \\
& + \dot{\gamma}_K \left[(\alpha - R) \left(a_K \frac{L^3}{3} + b_K \frac{L^4}{4} + c_K \frac{L^5}{5} \right) \right] \\
& = \alpha (\rho_K v_K T_K - \rho_{K+1} v_{K+1} T_{K+1}) + \frac{1}{2} (\rho_K v_K^3 - \rho_{K+1} v_{K+1}^3) \\
& (\dot{Q}(K) - \dot{W}(K)) / A
\end{aligned}$$

With the derived equations, the computer can be used to generate the coefficients of the derivatives and then to solve for the derivatives.