

AD 747688

A COMPARISON OF VISUAL CUIING METHODS
IN LARGE DISPLAYS
DURING PERFORMANCE OF A SECONDARY TASK

A Thesis

by

JOHN EDGAR RANKIN

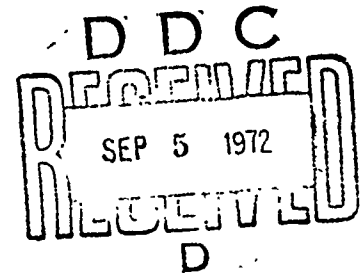

Submitted to the Graduate College of
Texas A&M University in
partial fulfillment of the requirement for the degree of
MASTER OF SCIENCE

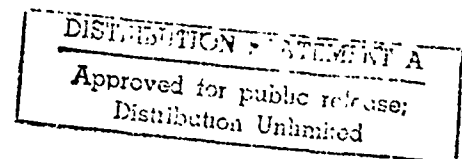

December 1971

Major Subject: Industrial Engineering

Reproduced by
NATIONAL TECHNICAL
INFORMATION SERVICE
U.S. Department of Commerce
Springfield VA 22151

59

UNCLASSIFIED
Security Classification

DOCUMENT CONTROL DATA - R & D

(Security classification of title, body of abstract and indexing annotation must be entered when the overall report is classified)

1. ORIGINATING ACTIVITY (Corporate author) USAMC Intern Training Center - USALMC ATTN: AMXMC-ITC-E-S Red River Army Depot Texarkana, Texas 75501		2a. REPORT SECURITY CLASSIFICATION UNCLASSIFIED	
		2b. GROUP N/A	
3. REPORT TITLE A COMPARISON OF VISUAL CUING METHODS IN LARGE DISPLAYS DURING PERFORMANCE OF A SECONDARY TASK			
4. DESCRIPTIVE NOTES (Type of report and inclusive dates) N/A			
5. AUTHOR(S) (First name, middle initial, last name) John E. Rankin			
6. REPORT DATE Dec 71		7a. TOTAL NO. OF PAGES 58	7b. NO. OF REFS 36
8a. CONTRACT OR GRANT NO. N/A		8b. ORIGINATOR'S REPORT NUMBER(S) N/A	
8c. PROJECT NO. c. d.		8d. OTHER REPORT NO(S) (Any other numbers that may be assigned this report) N/A	
10. DISTRIBUTION STATEMENT Distribution of this document is unlimited.			
11. SUPPLEMENTARY NOTES N/A		12. SPONSORING MILITARY ACTIVITY Safety Office Hq, US Army Materiel Command Washington, D. C. 20315	
13. ABSTRACT A study was conducted to investigate five alternative methods of visual cuing as applied to large display panels with the operator engaged in a secondary loading task. The cuing techniques compared were: color coding; spatial cuing, linear cuing; and color-modified versions of spatial and linear cuing. A total of 25 subjects were randomly assigned to five groups of five subjects each. Each group was then tested under one of the five cuing conditions. Reaction times to light stimuli were used as the basis of comparison. Subsequent analysis of reaction time data found no significant difference between cuing techniques.			

DD FORM 1473
NOV 68

REPLACES DD FORM 1473, 1 JAN 64, WHICH IS
OBSOLETE FOR ARMY USE.

UNCLASSIFIED

Security Classification

A COMPARISON OF VISUAL CUIING METHODS
IN LARGE DISPLAYS
DURING PERFORMANCE OF A SECONDARY TASK

A Thesis

by

JOHN EDGAR RANKIN

Approved as to style and content by:

(Chairman of Committee)

(Head of Department)

(Member)

(Member)

December 1971

ABSTRACT

A Comparison of Visual Cuing Methods in Large Displays
During Performance of a Secondary Task.

(December 1971)

John Edgar Rankin, B.S., Northwestern University

Directed by: Dr. N. C. Ellis

A study was conducted to investigate five alternative methods of visual cuing as applied to large display panels with the operator engaged in a secondary loading task. The cuing techniques compared were: color coding; spatial cuing; linear cuing; and color-modified versions of spatial and linear cuing. A total of 25 subjects were randomly assigned to five groups of five subjects each. Each group was then tested under one of the five cuing conditions. Reaction times to light stimuli were used as the basis of comparison. Subsequent analysis of reaction time data found no significant difference between cuing techniques.

ACKNOWLEDGEMENTS

I would sincerely like to thank Dr. Newton C. Ellis, chairman of my graduate committee, for his assistance and counsel in the development of this thesis. My gratitude is also extended to Dr. Richard D. Huchingson and Dr. James M. Elliott for their time spent on my behalf as my graduate committee members, as well as to Dr. Paul N. Hale, Jr., whose assistance was invaluable in the early phases of the study.

These acknowledgements would not be complete without giving a special thanks to my wife, Barbara, for her patience, understanding and assistance during the course of my graduate program and the preparation of this manuscript.

The ideas, concepts, and results herein presented are those of the author and do not necessarily reflect approval or acceptance by the Department of the Army.

TABLE OF CONTENTS

	PAGE
ABSTRACT.....	iii
ACKNOWLEDGEMENTS.....	iv
LIST OF TABLES.....	vii
LIST OF FIGURES.....	viii
CHAPTER	
I. INTRODUCTION.....	1
The Problem.....	1
Study Hypothesis.....	4
Summary.....	5
II. LITERATURE REVIEW.....	6
General Background.....	6
Spatial Coding.....	9
Color Coding.....	11
Large Displays.....	14
Secondary Tasks.....	17
III. EXPERIMENTAL METHOD.....	19
Subjects.....	19
Apparatus.....	19
Display Panel.....	20
Pushbutton Control Board.....	20
Experimenter's Control Box.....	22
Study Conditions.....	25
Spatial Cuing (SC).....	25

Linear Cuing (LC).....	25
Color Cuing (CC).....	27
Color-Modified Spatial Cuing (CMS).....	27
Color-Modified Linear Cuing (CML).....	28
Secondary Task.....	28
Procedure.....	28
Analysis.....	32
IV. RESULTS.....	33
V. CONCLUSIONS.....	38
Discussion of Results.....	38
Recommendations for Further Study.....	39
REFERENCES.....	41
APPENDIX.....	45
VITA.....	50

LIST OF TABLES

	PAGE
TABLE 1 Total Reaction Times, by Subject.....	34
TABLE 2 One-Way Analysis of Variance of Study Conditions.....	35
TABLE 3 Rank Order of Cuing Conditions.....	36

LIST OF FIGURES

	PAGE
Figure 1. <u>Wiring schematic for display/control panels</u>	21
Figure 2. <u>Display system used in the experiment</u> ...	23
Figure 3. <u>Experimenter's control box and timer</u>	24
Figure 4. <u>Schematic representation of display/control relationships</u>	26
Figure 5. <u>Subject performing secondary task</u>	30
Figure 6. <u>Subject responding to light stimulus</u>	31

CHAPTER I

INTRODUCTION

The Problem

The growing number of visual displays required in today's sophisticated hardware systems has presented a problem to the display designer. Displays for such systems as military Command and Control centers have increased in size and complexity (Gabelman, 1969), and the designer has frequently been required to trade off accepted display principles with spatial location on the panel itself.

The premium area for locating visual displays has been defined as a 30° cone directly ahead of the operator (Morgan, Cook, Chapanis, and Lund, 1963), but large display systems, because of their size, have several visual indicators located in the peripheral vision area outside of this central viewing zone. Herein is the crux of the problem.

With more and more indicators being located outside of the prime visual area, the operator as a matter of fact is required to scan large panel areas containing

Human Factors, the journal of the Human Factors Society, was used as a pattern for this thesis.

numerous displays to acquire visual information. From this multiplicity of signals, he must visually detect some types of information and discriminate between other types. Having completed the scan task and interpreted the signals, he must then decide upon an appropriate motor response and make that response within prescribed time limitations. All of these factors increase his reaction time to the display signal. Reaction time is "the time interval elapsing between the beginning of the signal (stimulus) and the completion of the operator's response" (Morgan, et al, 1963), and frequently is the determinant between successful use and unsuccessful use of the display system.

The undesirability of the longer reaction time induced by large display panels is, of course, intrinsic to the particular system and situation. In a non-critical situation long reaction time may be of little or no consequence. When considering a crucial control situation, however, it may be in the best interests of the system to keep reaction time as short as possible. For emergency control panels, reaction time is of vital importance and in this case is frequently the determining factor between mission success or failure.

It is not reasonable to assume that in all circumstances the operator is solely concerned with direct

monitoring of the display. A case in point would be the operator who must continually make written recordings of system performance, or the radar monitor who must from time to time check the entire system to insure that it is operating properly. It can be seen that the inclusion of auxiliary tasks in the total job of the display monitor generally reduces degree of readiness of the operator to respond to emergency control situations. Thus, in the equation: Reaction Time = Sensing Time + Decision Time + Response Time (Morgan, et al, 1963), sensing time is increased. As mentioned earlier, display size itself has a direct influence on reaction time and, specifically, on sensing time. If one or both of the other components of reaction time could be reduced, it should negate a portion of the detrimental aspects induced by display size and the secondary task. In either case, the question of whether or not large displays in current operational use are being, or can be, used efficiently must be raised.

It is thought that visual cuing may be one of the techniques that might improve system efficiency by reducing operator reaction time, specifically in the case where the operator is engaged in a secondary loading task aside from the direct monitoring of the large display. Cuing is said to be the provision of

information before or during a response, such that the probability of occurrence of the response is greater than if such information were not provided (Annett and Clarkson, 1964).

The present study investigates the use of visual cuing in reducing the identification component of reaction time for large display systems in which secondary tasks are also required. Five cuing techniques have been identified for subsequent comparison: color coding; linear cuing; spatial cuing; and color-modified versions of spatial and linear cuing. The results of the experiment may prove significant in the design of large display systems with secondary loading tasks, thereby increasing system efficiency.

Study Hypothesis

It may generally be assumed that the characteristics of stimulus presentations which reduce identification time would also have a direct influence on the speed and accuracy of human response. The present study was conducted to determine what amount of identification time could be saved in single stimulus presentations where techniques of color coding and spatial cuing have been employed.

This study compares the five techniques of visual cuing identified previously and described in Chapter III. It was postulated that the technique which reduces time to identify the source of the displayed signal would also lead to a reduction in total reaction time. Within this general postulate, it was hypothesized that the five cuing techniques would rank with regard to reaction time (from shortest to longest) in the following manner:

1. color-modified spatial cuing
2. spatial cuing
3. color-modified linear cuing
4. linear cuing
5. color cuing.

Summary

This paragraph briefly summarizes the remainder of this report. Chapter II reviews the available literature concerning various aspects of the present research: general background; spatial coding; color coding; large displays; and secondary tasks. Chapter III describes the experimental method used in the research including subjects, apparatus, study conditions, the secondary task, and the procedure used. Chapter IV presents the results, and Chapter V discusses the conclusions drawn and makes recommendations for further study.

CHAPTER II

LITERATURE REVIEW

In reviewing some of the available literature, numerous studies were found which touched on various aspects of the present investigation. These include such aspects as spatial coding, color coding, large displays, and secondary tasks. Each of these topics, therefore, will be treated separately in succeeding sections of this chapter.

General Background

With respect to reaction time, both the characteristics of the cue, itself, and those of the panel to which the technique is applied must be considered. McCormick (1970) lists location, perception, meaning, identification, and background characteristics as factors to be considered for visual indicators or warning signals. McCormick also states that lights are the display devices most typically used to present dynamic information and warnings.

Many studies have been conducted which deal with display coding in general. There appears to have been, however, relatively little work conducted that applies visual cuing in a strict operational sense. Stirner,

Siegel, and Fox (1957) investigated the effects of a master caution indicator on the responses to peripherally located light panels. Though the master indicator helped to ensure that the operator observed the signals, it had no significant effect on reaction time. Annett and Clarkson (1964) have applied cuing to training tasks, but did not consider its possible effect on efficiency in operational task performance.

Work has also been conducted that touches upon specific aspects of the total cuing problem. Reaction times were found by Andreassi and Huntly (1967) to be faster when the operator was subjected to signals presented with a fixed time interval between each response completion and the succeeding stimulus presentation, than when a variable stimulus presentation schedule was used. Ellis (1968) found that the operator's detection time could be decreased by requiring him to perform a systematic visual scan of the display panel. Both of these studies suggested that patterned observation would improve reaction times to displays.

Although the major factor considered in display coding is the stimulus-response relationship, some consideration must be given to the response mechanism itself. Pushbuttons were selected as the control devices for the present study as the time required to

activate each device is relatively short and fairly constant as compared to other devices (Morgan, et al, 1963).

Reach distance also affects reaction time. Aume (1963) investigated the effect of reach distance on reach time in a button pushing task. In this study, a corresponding signal light was placed directly above each of eight pushbuttons mounted on a panel that could be moved in order to measure reach time for various reach distances. It was found that reach time does, indeed, increase with increasing reach distances, but the relationship is not necessarily linear. Reach time was also found to increase according to the difficulty of aiming and the number of pushbuttons in a column.

Harvey (1971) studied the effects of various techniques of cuing with respect to reduced reaction time under limited simulated operational conditions. In his comparison of conventional, color, and spatial cuing methods, he found no significant difference between the effects of spatial and conventional cuing on human performance. Conventional cuing refers to the technique where the signal light is adjacent to its control device, as used in the study by Aume mentioned above. Color cuing had the greatest reaction time. Though his results may have application to medium sized

panels where the operator is concerned solely with observing and responding to visual stimuli, they do not appear applicable to large display systems where a secondary task is also required.

Spatial Coding

Much work has been done to establish the relative effectiveness of various spatial display/control relationships. Generally speaking, the stimulus-response codes which are the most compatible and/or the simplest, normally result in the shortest reaction times.

Knowles, Garvey, and Newlin (1953) evaluated several display/control systems which incorporated the same group of displays and controls. Some display/control relationships, those which were the more spatially compatible, were determined more efficient than others. In interpreting their results within the framework of information theory, it was determined that the subjects were able to use a simpler procedure to transmit information from display to control in the more efficient systems. In a follow-up study (Garvey and Knowles, 1954), relative efficiency of the systems was found to remain the same throughout an extended period of practice.

Fitts and Seeger (1953) also investigated effects of varying both stimulus and response sets to form combinations with different degrees of stimulus-response compatibility. The study considered conditions in which relevant information in the stimulus source was generated by changes in its spatial characteristics, whereas the relevant aspect of the response was its direction of movement. That is, the response required of the subjects was to move a stylus quickly in the direction indicated by a stimulus light(s). It was found that reaction time is shortest for stimulus and response sets that agree closely with the basic habits and expectancies of individuals.

Chapanis and Lockheed (1965) conducted an experiment to test the effectiveness of sensor lines on simple display/control panels made up of small signal lights and pushbuttons. Sensor lines are heavy lines drawn on a control panel to show the linkages between displays and controls. The results indicate that it is more important to make the relationship between displays and controls compatible (by spatial correspondence) than it is to use sensor lines. The lines did prove useful, however, when the display/control relationship was not spatially compatible.

In a study comparing spatial and alphabetic encoding of information on a visual display, Newman and Davis (1961) found that simple spatial encoding leads to good performance with respect to both speed and accuracy. They also found that even a fairly complex spatial code would improve response speed significantly in a task requiring rapid detection. Newman and Davis, in their recommendations for further research, suggested an investigation of display codes combining spatial and color encoding.

Color Coding

Presently, the colors most frequently used for lights on industrial control panels are red and green (Dudek and Colton, 1970). This is possibly due to the fact that lights have primarily been used for the purpose of presenting dichotomous information. It is likely, however, that more colors will be required for indicator lights due to increased automation and complexity of equipment. Increasing reliance on computers and related data display outputs in complex systems has prompted many investigations in recent years where color is used as a coding device.

In a comprehensive review of the research published at the time, Jones (1962) discusses many of the

applications and restrictions of color coding. Much of the early research sought to establish the number of code values (alphabet size) that can be identified on the basis of absolute judgement. For optimal viewing conditions, as many as 9 to 12 colors can be distinguished reliably (Chapanis and Halsey, 1956; Halsey and Chapanis, 1951), but it is suggested that a color alphabet of 5 to 8 hues be used under normal conditions (Conover, 1959; Conover and Kraft, 1958; Eriksen and Hake, 1955). Thus, it is evident that color as a coding dimension can be used to distinguish only a rather small number of categories. With respect to identifications of surface and luminous hues, the method of absolute judgement yielded similar findings.

Later studies attempt to take into account certain existing systems' parameters. The criteria for code selection in a given situation, for instance, were found to depend not only upon the number of items to be differentially identified, but also upon display complexity and the type of task for which the code operates. Specifically, color coding does not appear to be suited for situations demanding rapid and precise identification. In comparison to numerals, for instance, color-type codes were found to be inferior under conditions of brief stimulus presentation in terms of both speed and

accuracy of response (Allusi and Muller, 1958; Anderson and Fitts, 1958).

In contrast, color codes have proven particularly valuable in decreasing search time for locate-type and counting tasks in dense displays (Green and Anderson, 1956; Shontz, Trumm, and Williams, 1971; Smith, 1962a; Smith, 1963). The particular color of the display target does not appear to influence search performance (Smith, 1962a; Smith, 1963).

It is generally accepted that backgrounds of various colors have no effect upon responses to colored targets. Bishop and Crook (1961), using backgrounds of red, white, blue, and green, reported no systematic effects when target purity was high or moderate in an absolute judgement task. Backgrounds of either white or black were also found to have no differential effect in a search task using color-coded numerals (Smith, 1962a).

In a more recent study, however, Dudek and Colton (1970) determined that the color of background does have a definite effect on the distance at which a color is recognized using peripheral vision. An apparent change in color occurs as a colored light is moved into the visual field, or when it is located near the edge of the peripheral vision area. It was found that the color of

background and the level of environmental light both affect the recognition distance of color and the number of errors made, with the darker backgrounds and lower illumination levels yielding superior results. Specifically, blue and yellow lights, on a gray background, under a low level of environmental light, gave the best results.

Large Displays

There are numerous cases in both industry and the military where large display systems are in use. Air traffic control centers, data processing systems, radar rooms, manned spaceflight control centers, and naval control centers are but a few of the facilities using large wall-size display systems. Large screen display systems of 6 meters by 6 meters and larger have been used by the U.S. Air Force in operational Command and Control installations (Gabelman, 1969). In most situations, displays are used in the vertical position, although some cases may warrant the use of a horizontal display (Hopkin, 1969). In some of these instances, these displays are shared by a number of human operators; in others, there is a single human monitor.

A variety of both functional and non-functional considerations, as well as historical factors, tend to

influence choice as to display size. In a discussion of the relative merits of large and small displays, Smith (1962b) asserts that the basic consideration is one of whether the display is to serve an individual or a group of people. It is obvious that if a single display is to simultaneously serve the needs of a number of individuals, it should necessarily be large enough to be viewed by all. On the other hand, large and small displays are equivalent in terms of the amount of information which can be presented to a single observer. Non-functional considerations such as implied status or aesthetics often lead to the selection of a large display for a purpose that could equally be served by a small display in terms of viewing angle and legibility.

Two studies have been conducted to establish the relative worth of group displays as compared to individual displays. Hammer and Ringel (1965) evaluated individual and group displays using size-coded and uncoded updates. Location times for coded updates were essentially equal for individual and group displays, but the times to locate uncoded updates were shorter with the individual displays by about 15 percent. Their conclusion was that information assimilation tasks may be more efficiently accomplished with individual rather than group displays when using uncoded, updated

Information. They emphasized that the main factor in the choice of an individual or a group display is the nature of the task to be performed. Smith and Duggar (1965), however, found performance to be 15 percent faster with a large group display in a search-and-counting task than for small individual displays. This, however, was not attributable to display variables, but to the fact that the groups were able to implement a time-sharing procedure which facilitated the search process. Thus, the display differences found can be attributed to group interactions, and not to display factors.

In some situations, the use of large wall-size displays presents a problem in that the observer must often resort to peripheral vision to pick up visual signals. It is customary to assume a solid angle of 30° as containing the optimum viewing area for visual displays (Morgan, et al, 1963; Smith, 1962b; Stirner, et al, 1957). This 30° value is for eye movement only. Kobrick (1966), however, found that a flashing light displaced by as much as 55° along the horizontal line of sight, and above the horizontal by as much as 30° , could be detected as well as one centrally located. Kobrick did not consider the case where both the head and eyes are permitted to move. The maximum accepted

viewing angles from the line of sight for this case are: 75° up; 85° down; and 95° left or right (Morgan, et al, 1963; Smith, 1962b).

Secondary Tasks

Knowles (1963) cites two reasons for the use of a secondary task in part-task simulation studies. The first use of a secondary task is to simulate factors of the total job that may be missing. Pressure is put on the primary task, thereby degrading operator performance to a level that might be expected in a total-job situation. The second application of an auxiliary task is one of determining the amount of additional work that may be accomplished by the operator while still performing the primary task at an acceptable level. Thus, secondary task performance measures may be used as an indicator of the price paid in operator effort in meeting system performance criteria.

The purpose of including a secondary task in the present study is more closely related to the first of Knowles's objectives in the sense that the experiment sought to provide a realistic operational situation. Knowles also suggests that the secondary task be easy, overlearned, composed of discrete messages, and

demanding enough attention so that the operator cannot ignore it.

A secondary task, mental arithmetic, was included during a portion of the study investigating the spatial characteristics of stimulus-response compatibility by Fitts and Seeger (1953). The secondary task was introduced to test the hypothesis that the least compatible stimulus-response set would show the most deterioration under additional loading. The results showed a definite increase in reaction times for all stimulus-response sets, but were otherwise inconclusive.

Garvey and Knowles (1954) also included an auxiliary task in a portion of their study to determine if its introduction would have the same interfering effect on the operation of all the display-control systems tested. The secondary task had no significant effect on operator performance in the most efficient systems. It did have, however, a substantial interfering effect on the performance of the least efficient systems.

CHAPTER III

EXPERIMENTAL METHOD

The material in this chapter describes the subjects, apparatus, study conditions, secondary task, procedure, and methods of analysis used in the conduct of the experiment.

Subjects

The study was conducted using 25 male undergraduate and graduate students and faculty members of Texas A&M University. All of the subjects were right-handed and between 19 and 33 years of age. Subjects were also screened for normal color vision and normal, or corrected-to-normal, acuity.

Apparatus

During the experiment, the subjects were required to wear earphones through which white noise, or static, was transmitted. The purpose of the earphones was to mask any noise that might be distracting to the subject (specifically, the closing of the relay when a signal light was turned on by the experimenter).

The room in which the experiment was conducted was kept at a high level of ambient light. This was

achieved by the use of three unshielded, incandescent, 100-watt lights placed behind the subject.

The remainder of the experimental apparatus consisted of three basic elements: a display panel; a pushbutton control board; and the experimenter's control box. The electrical components of these elements were connected according to the wiring schematic shown in Figure 1.

Display Panel

A large flat wall (8 feet by 10 feet) was used as a display surface. Six small panels (16 inches by 10 inches) were then mounted on the wall in two rows of three. Both the wall and the panels were off-white in color. Signal lights were mounted in the center of each small panel. The lights were of the common 7-watt variety. The top row of lights was 12 inches from the top of the wall, with the bottom row located 40 inches below the upper one. The lights in each row were separated by approximately 55 inches.

Pushbutton Control Board

A control panel containing six pushbuttons was placed on a table in front and slightly to the right of the subject. The control panel consisted of two

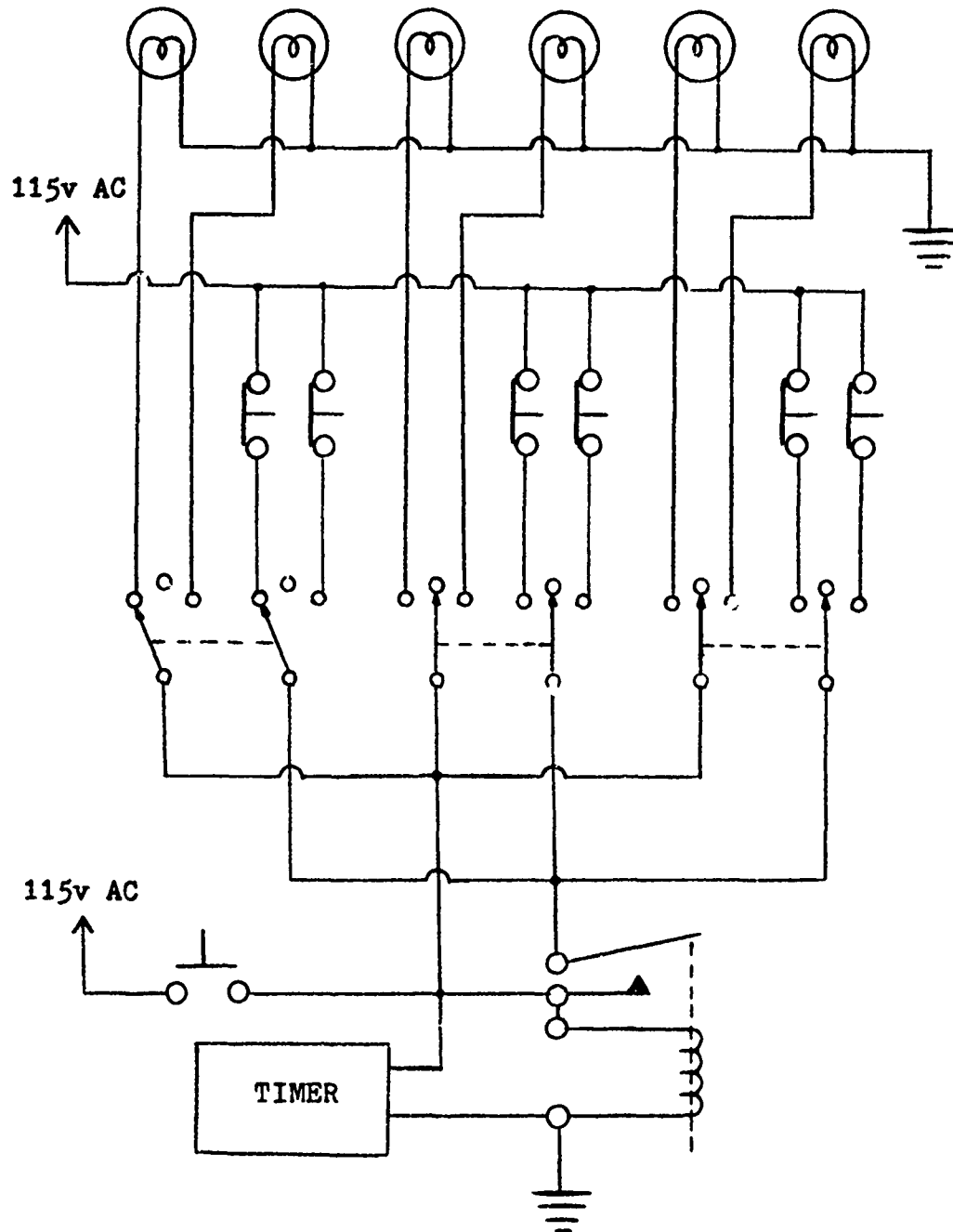

Figure 1. Wiring schematic for display/control panels.

metal electrical boxes (12 inches by 4 inches by $4\frac{1}{2}$ inches) with three one-inch diameter pushbuttons mounted on each box. The boxes could then be arranged in the positions dictated by the various study conditions.

The table, covered with black non-reflective construction paper, was situated so that, when seated, the operator was approximately 42 inches from the center of the large display. With this arrangement, the total viewing angle for the operator (between lights) was approximately 52° to the left or right along the horizontal line of sight and 43° above the horizontal. The display/control arrangement is pictured in Figure 2.

Experimenter's Control Box

The experimenter's controls, pictured with the timer in Figure 3, consisted of three double-pole, double-throw toggle switches and a start button (the wafer switch shown had no function). This enabled the experimenter to select one signal light at a time, using the switches, and then to turn on the light by means of the pushbutton. The box also housed the electrical relay.

A timer was incorporated in the circuitry of the display/control panels so that the reaction time for each light presentation could be recorded.

Figure 2. Display system used in the experiment.

Figure 3. Experimenter's control box and timer.

Study Conditions

Five coding techniques were incorporated in the study. These five are described below and summarized schematically in Figure 4. The transition from the spatial- and linear-white-light conditions to the color conditions was achieved simply by substituting colored light bulbs on the display panel and placing the colored overlay, described below, on the pushbutton control board.

Spatial Cuing (SC)

To investigate spatial cuing, the arrangement of the pushbuttons on the subject's control panel corresponded to the spatial arrangement of the lights on the display panel. White lights were used.

Linear Cuing (LC)

Linear cuing, as referred to here, employed the same white lights as those used for spatial cuing. The pushbuttons, however, were arranged in a horizontal line so that the three on the left corresponded to the top row of lights, and the three on the right corresponded to the bottom row of lights.

A (Green)	B (Brown)	C (White)
D (Red)	E (Yellow)	F (Blue)

Display Panel

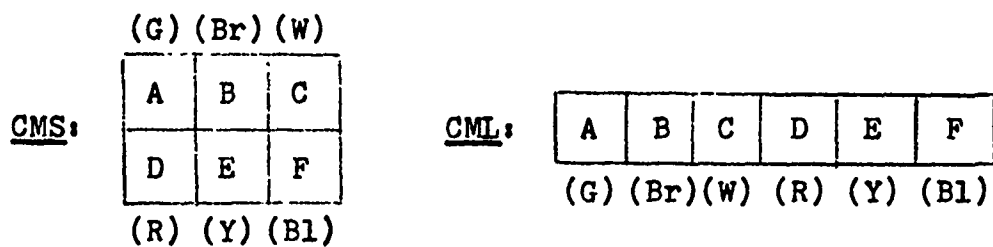
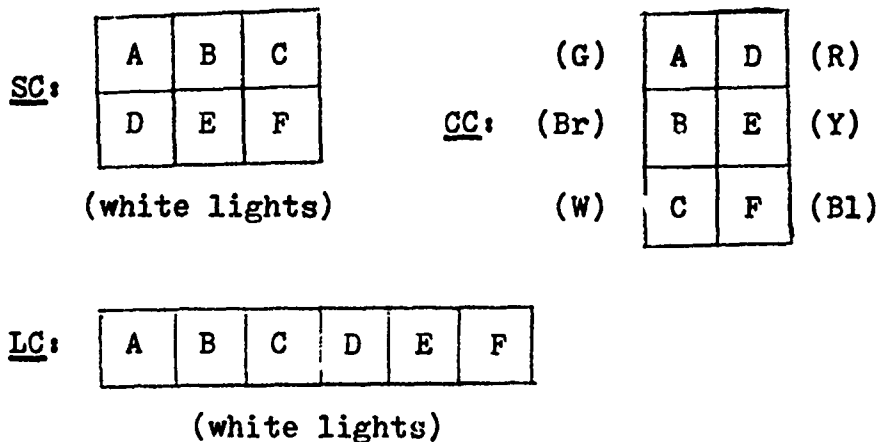

Pushbutton Arrangements on Control Board

Figure 4. Schematic representation of display/control relationships.

Color Cuing (CC)

For color cuing, the light-pushbutton correspondence was according to color. That is, each light had a unique color, and a colored overlay was placed over the control panel so that each pushbutton was surrounded by one of six colored areas and corresponded to the indicator light of the same color. The colors used were: red; white; yellow; blue; green; and brown. Colors close to one another in the visual spectrum were placed in non-adjacent positions on the display. The positions of the colors relative to one another on the display/control panels are indicated in Figure 4 (p. 26). In order to avoid any spatial relationship between lights and pushbuttons, the pushbuttons were arranged in three rows of two.

Color-Modified Spatial Cuing (CMS)

The light-pushbutton arrangement for this portion of the experiment was identical to that used for spatial cuing. Colored lights and a colored overlay for the pushbuttons, however, were employed so that use of color provided a redundant light-pushbutton correspondence.

Color-Modified Linear Cuing (CML)

Colored lights and a colored overlay were used here as they were in CMS, but the pushbutton arrangement was identical to that used for linear cuing.

Secondary Task

During the experiment, each subject was required to perform a simple secondary task of counting rows of X's on a sheet of paper. It was designed to require some attention on the part of the subject during which he was forced to make his own periodic scan of the large display for visual signals. The number of X's in each row was randomly determined with the restriction that it range from 2 to 14.

Procedure

Prior to beginning the experiment, each subject was instructed as to the purpose of the experiment, the operation of the pushbuttons, and secondary task performance (see Appendix). The subject was then given a practice period so that he would be able to associate each signal light with its respective pushbutton for the particular cuing format on which he was being tested.

At the start of the experiment, the subject was seated and performing the secondary task, using his right hand to record answers to the secondary task problems. Signal lights were then turned on remotely and randomly by the experimenter. For each of these single stimulus presentations, the subject was then to press the corresponding pushbutton with his right hand, without dropping his pencil, thereby turning off the signal light. He was then to return to the secondary task. The above procedure was used for each of the five cuing methods.

Figures 5 and 6 portray an example subject performing the experimental tasks. Figure 5 pictures the subject during secondary task performance. The pushbuttons here are arranged for the CML condition. In Figure 6, he is seen responding to the white light in CC.

Each subject was given three trials in the course of the experiment. Each trial consisted of 18 light presentations, with the order of presentations randomized, but with the restriction that each individual light be presented three times. The subject was stopped at the end of each trial, given a short period of rest, and then instructed to continue, picking up where he left off on the secondary task sheets. The time period

Figure 5. Subject performing secondary task.

Figure 6. Subject responding to light stimulus.

between light presentations was randomly determined by the experimenter, consisting of from five- to twenty-second intervals. The reaction time recorded for each light presentation was the time interval between the experimenter's turning on of the light and the time when the light was turned off by the subject.

Analysis

A randomized-blocks design was used in the analysis of the experiment. Subjects were randomly assigned to five blocks of five subjects each. These blocks of subjects were then randomly assigned and tested under the five conditions of cuing.

The reaction times recorded in each experimental session were summed. These totals were analyzed using a standard one-way analysis of variance technique to determine whether or not the five cuing techniques differed significantly with respect to overall reaction time.

The hypothesized rank-order of the cuing conditions was tested by comparing it to the resulting order using a nonparametric rank test. The results of these analyses are presented in Chapter IV.

CHAPTER IV

RESULTS

A tabular summary of the results is shown in Table 1. The values on the table represent the total reaction time of each subject to the 84 light presentations of each experimental session.

A simple one-way analysis of variance (Hicks, 1964) by study conditions was performed. These results are shown in Table 2. As indicated, no significant difference was found between the five cuing techniques at the 0.25 significance level with respect to reaction time.

Kendall's Rank Order Test (Siegel, 1956) was performed to determine the validity of the study hypothesis concerning the rank order of cuing conditions. The Kendall test operates under the null hypothesis that the rank orders to be compared are unrelated. For the case at hand, the rank orders for both the study hypothesis and the results are shown in Table 3. The values entered on the table indicate the rank (from the shortest total reaction time to the longest) of the five conditions of cuing. The resulting Kendall Rank Correlation Coefficient has a value of 0.20. The corresponding probability that the coefficient would be

TABLE 1

Total Reaction Times, by Subject

	<u>SC</u>	<u>LC</u>	<u>CC</u>	<u>CMS</u>	<u>CML</u>
	153.70	110.44	137.90	162.06	145.90
	92.14	90.99	106.44	105.90	112.37
	102.34	106.34	133.51	97.13	119.90
	80.17	91.11	161.29	149.90	110.99
	84.27	172.67	135.08	150.68	175.67
Totals:	512.62	571.55	674.22	665.67	664.83

TABLE 2
One-Way Analysis of Variance of Study Conditions

<u>Source of Variance</u>	<u>df</u>	<u>SS</u>	<u>MS</u>	<u>F</u>
Between Conditions	4	4177.69	1044.42	1.29
Within Conditions	20	16175.99	808.80	
Total	24	20353.68		

$$(F_{0.25} = 1.46)$$

TABLE 3
Rank Order of Cuing Conditions

	<u>CMS</u>	<u>SC</u>	<u>CML</u>	<u>LC</u>	<u>CC</u>
Hypothesized Ranks	1	2	3	4	5
Resulting Ranks	4	1	3	2	5

Kendall Rank Correlation Coefficient = 0.20

between the value found and 1.00 (perfect correlation) is 0.408. Thus, the Kendall null hypothesis cannot be rejected. This, in turn, dictates that the original rank order study hypothesis must be rejected.

CHAPTER V

CONCLUSIONS

Discussion of Results

The results of the experiment indicate that color, spatial, or color-spatial combinations may be used as a coding device with equal effectiveness in systems employing large displays and secondary loading tasks.

Though reaction times for the five cuing techniques proved not to be significantly different, there are a number of factors which may have interacted to produce these results. Display size, reach distance for response, subject posture, and secondary task performance are but a few of the aspects within the total experiment that may have affected the results. Nevertheless, all of these are components of the total job situation. Thus, there is significance in the fact that no appreciable difference was detected between cuing techniques.

The secondary task was included in the study in an effort to simulate a total job situation. It has previously been shown that spatial cuing produces shorter reaction times than does color cuing in a situation where the operator is concerned only with responding to light signals (Harvey, 1971). It may be that the

secondary task had an interfering effect upon reaction times, and possibly this effect was different for the various techniques tested. It is therefore evident that the total work situation must be considered when applying experimental results to operational systems. It is further implied that pure scanning test data are not reasonably applicable to display systems requiring auxiliary operator tasks.

In the design of display systems, decisions must be made concerning the optimum display/control relationship which may be used. Large displays preclude the placement of controls in positions adjacent to their corresponding display. Thus, a remote correspondence is necessitated. The results of the present study suggest that, in a decision between spatial coding, color coding, and color-redundant spatial coding, the assigned priorities should be as follows:

1. spatial codes
2. color-redundant spatial codes
3. color codes.

Recommendations for Further Study

Further study is needed in the area of display coding which combines spatial and color codes. Two studies are suggested here: the first would include the use of sound as a master caution indicator; the second

would use flashing lights as detection devices. The results of such studies should prove applicable in the design of emergency control panels. That is, if the panel is first to serve the purpose of warning detection, then the relative worth of sound or flashing lights could be determined. Color and spatial encoding would be used as an aid in the identification of proper control response. It is suggested that subjects be provided with sufficient training prior to testing, with particular emphasis placed on training under the color coding conditions.

It is emphasized that the use of auxiliary tasks be made in all future studies of display coding. It is evident from the results presented in this report that the findings of studies employing pure stimulus-response tasks are not necessarily accurate predictions of human performance in operational systems.

REFERENCES

- Alluisi, E. A. and Muller, P. F., Jr. Verbal motor responses to seven symbolic visual codes: a study in S-R compatibility. Journal of Experimental Psychology, 1958, 55, 247-254.
- Anderson, Nancy S. and Fitts, P. M. Amount of information gained during brief exposures of numerals and colors. Journal of Experimental Psychology, 1958, 56, 362-369.
- Andreassi, J. L. and Huntly, M. S. Effects of signal patterning upon vigilance performance and physiological responses. Technical Report IH-62, U. S. Naval Training Device Center, Orlando, Florida, 1967.
- Annett, J. and Clarkson, J. K. The use of cuing in training tasks. Technical Report 3143-1, U. S. Naval Training Device Center, Orlando, Florida, 1964. (DDC Document AD-601 352).
- Aume, N. M. The effect of reach distance on reach time in a button pushing task. Aerospace Medical Research Labs, Wright-Patterson AFB, Ohio, October 1963. (DDC Document AD-425 558).
- Bishop, H. P. and Crook, M. H. Absolute identification of color for targets presented against white and colored backgrounds. USAF WADD Technical Report 60-611, 1961.
- Chapanis, A. and Halsey, Rita M. Absolute judgements of spectrum colors. Journal of Psychology, 1956, 42, 99-103.
- Chapanis, A. and Lockheed, G. R. A test of the effectiveness of sensor lines showing linkages between displays and controls. Human Factors, 1965, 2, 219-229.
- Conover, D. W. The amount of information in the absolute judgement of Munsell hues. USAF WADC Technical Note 58-262, 1959.
- Conover, D. W. and Kraft, C. L. The use of color in coding displays. USAF WADC Technical Report 55-471, 1958.

- Dudek, R. A. and Colton, G. M. Effects of lighting and background with common signal lights on human peripheral color vision. Human Factors, 1970, 12, 401-407.
- Ellis, K. Methods of scanning a large visual display. Occupational Psychology, 1968, 42, 181-187.
- Eriksen, C. W. and Hake, H. W. Multidimensional stimulus differences and accuracy of discrimination. Journal of Experimental Psychology, 1955, 50, 153-160.
- Fitts, P. M. and Seeger, C. M. S-R compatibility: spatial characteristics of stimulus and response codes. Journal of Experimental Psychology, 1953, 46, 199-210.
- Gabelman, I. J. (Ed.). Displays for Command and Control Centers. Slough, England: Technivision Services, 1969.
- Garvey, W. D. and Knowles, W. B. Response time pattern associated with various display-control relationships. Journal of Experimental Psychology, 1954, 47, 315-322.
- Green, B. F. and Anderson, L. K. Color coding in a visual search task. Journal of Experimental Psychology, 1956, 51, 19-24.
- Halsey, Rita M. and Chapanis, A. On the number of absolutely identifiable spectral hues. Journal of the Optical Society of America, 1951, 51, 19-24.
- Hammer, C. H. and Ringel, S. Information assimilation from coded and uncoded individual and group displays. Human Factors, 1965, 7, 245-255.
- Harvey, M. E. An investigation of alternative methods of visual cuing. Unpublished research report, Industrial Engineering Department, Texas A&M University, 1971.
- Hicks, C. R. Fundamental Concepts in the Design of Experiments. New York: Holt, Rinehart and Winston, 1964.

- Hopkin, V. D. Vertical and horizontal dynamic displays for air traffic control. IAM Scientific Memorandum No. 84, RAF Institute of Aviation Medicine, Farnborough, England, January 1969. (DDC Document AD-857 699).
- Jones, Mari R. Color coding. Human Factors, 1962, 4, 355-365.
- Knowles, W. B. Operator loading tasks. Human Factors, 1963, 5, 155-161.
- Knowles, W. B., Garvey, W. D., and Newlin, E. P. The effects of "speed" and "load" on display-control relationships. Journal of Experimental Psychology, 1953, 46, 65-75.
- Kobrick, J. L. Effects of physical location of visual stimuli on intentional response time. U. S. Army Research Institute of Environmental Medicine, Natick, Mass., 1966. (DDC Document AD-633 591).
- McCormick, E. J. Human Factors Engineering. New York: McGraw-Hill, 1970.
- Morgan, C. T., Cook, J. S., Chapanis, A., and Lund, M. W. (Ed.). Human Engineering Guide to Equipment Design. New York: McGraw-Hill, 1963.
- Newman, K. M. and Davis, A. R. A comparison between spatial and alphabetic encoding of information on a visual display. U. S. Navy Electronics Laboratory, San Diego, California, December 1961. (DDC Document AD-670 619).
- Shontz, W. D., Trumm, G. A., and Williams, L. G. Color coding for information location. Human Factors, 1971, 13, 237-246.
- Siegel, S. Nonparametric Statistics for the Behavioral Sciences. New York: McGraw-Hill, 1956.
- Smith, S. L. Color coding and visual search. Journal of Experimental Psychology, 1962, 64, 434-440. (a)
- Smith, S. L. Visual displays--large and small. AFESD Technical Report 62-338, Air Force Electronic Systems Division, Bedford, Mass., November 1962. (DDC Document AD-293 826). (b)

Smith, S. L. Color coding and visual separability in information displays. Journal of Applied Psychology, 1963, 47, 358-364.

Smith, S. L. and Duggar, B. C. Do large shared displays facilitate group effort? Human Factors, 1965, 7, 237-244.

Stirner, F. W., Siegel, A. I., and Fox, B. H. Caution and warning light indicators for naval aircraft: III. An experimental investigation into the advantages of a 'master' caution indicator. Contract No. N156 S-33252, Applied Psychological Services, Villanova, Pa., 1957.

APPENDIX

INSTRUCTIONS TO SUBJECTS

The experiment in which you are about to participate is one measuring human performance in simple tasks. It is not a measure of intelligence, nor is it to be taken as a reflection upon your personal ability. Let me reassure you that the experiment is in no way designed to humiliate you. The tasks are really quite easy. You are simply to count rows of X's and make button pushing responses to light presentations. Please be seated.

(Subject seated at table) The large display in front of you has six signal lights as you can see (point). The control panel here on the table (point) is provided with six pushbuttons. There is a one-to-one correspondence between each light and its respective pushbutton. This correspondence is as follows:

Spatial

As you can see, the lights and pushbuttons are arranged in two rows of three. There is a spatial relationship between the lights and pushbuttons. For example, the signal light in the upper right-hand corner (point) corresponds to the pushbutton in the

same position on the control panel (point).

Linear

There are two rows of three lights on the large display panel. The pushbuttons here (point) on the control panel are arranged in a single row of six. The three pushbuttons on the left (point) correspond spatially to the top row of lights. Those on the right correspond to the bottom row. Thus the light in the bottom left-hand corner relates to the fourth pushbutton from the left (point).

Color

The six lights on the large display panel are each of a different color. The pushbuttons here (point) are each surrounded by a unique color field. Consequently, each pushbutton corresponds to the light with the identical color as that surrounding the pushbutton. Thus, the white light in the upper right-hand corner corresponds to the pushbutton within this white field (point). You may also consider the display arrangement as three columns of two lights each. These columns are then rotated 90° counter-clockwise to form the arrangement here on the control panel (point).

Color-Modified Spatial

(Same instructions as those for Spatial plus the following:) The lights are also colored, and each of the pushbuttons is surrounded by a unique color field. Thus, the pushbutton associated with the white light in the upper right-hand corner is further identified by this white color field (point).

Color-Modified Linear

(Same instructions as those for Linear plus the following:) The lights are also colored, and each of the pushbuttons is surrounded by a unique color field. Thus, the pushbutton associated with this red light in the lower left-hand corner is further identified by this red color field (point).

The remaining lights and pushbuttons correspond identically in the manner outlined. Are there any questions at this time?

There are two tasks in this study. The first task relates to the material on the desk. This task is one of counting rows of X's on these sheets of paper (point). As you can see, each sheet has three columns. You are to work down each of these columns, starting with the column on the left. You are to record

the number of X's in each row on the line to the left of each set of X's. As the results of this portion of the experiment will be graded, you should work as quickly and as accurately as possible.

The second task relates to the large display and the pushbutton control panel. At various time intervals during the experiment, I will turn on each signal light in a random order. I will be situated there (point) in the area behind you. Your task is to press the correct, i.e., corresponding pushbutton as quickly as possible each time a light is turned on. You are to do so with your right hand, using your fingers like so (demonstrate), without dropping your pencil.

You are to regard both the counting task and the button-pushing task as having equal importance. During the study you will be performing both tasks at the same time. You will start with the pencil and paper task. Every five to ten seconds you are to scan the display panel for visual signals. If there is a light on, or should you happen to see a light come on, stop the counting task and press the button that corresponds to that particular light. This will turn off the light. When the light goes off, you are to return to the paper and pencil task. You are to follow this procedure throughout the study.

Now, there will be a considerable amount of noise while the experiment is being conducted as far as you are concerned. This will consist of white noise, or static, as you can hear coming from these earphones (present earphones). You will wear these throughout the study so that you will not be distracted by any noise in the room or outside. Are there any questions?

We will now try a few practice rounds. Please indicate verbally when you feel comfortable with the system and are ready to begin the actual experiment. Are there any further questions? You may begin the counting task. (Proceed)

(The subject indicates his readiness to proceed.)
We will start now using a fresh sheet of paper (substitute new sheets). You may begin the counting task. (Proceed--18 presentations--3 per light)

Stop. We will now start a second (third) trial. Continue where you left off in the counting task. You may begin.

VITA

John Edgar Rankin was born in Akron, Ohio on September 15, 1948, and is the son of Edgar W. and Helen W. Rankin. Following graduation from Kenmore High School, Akron, Ohio in June, 1966, he attended Northwestern University, Evanston, Illinois, from which he received a Bachelor of Science degree in Industrial Engineering in June, 1970. He was then employed by the U.S. Army Materiel Command and began training as a safety engineer at the USAMC Intern Training Center at Red River Army Depot, Texarkana, Texas. In October, 1970, as part of this training, he enrolled in Texas A&M University as a graduate student in Industrial Engineering.

His permanent mailing address is as follows:

Mr. John E. Rankin
833 National Avenue
Akron, Ohio 44314.

The typist for this thesis was Mrs. John E. Rankin.