

AFML-TR-71-140
Part I



AD 748272

NEW TECHNIQUES IN NONDESTRUCTIVE TESTING (EXO-ELECTRON EMISSION PHASE)

Dr. Stuart A. Hoenig
Professor, Electrical Engineering
The University of Arizona

TECHNICAL REPORT AFML-TR-71-140, PART I

December 1971

Approved for public release; distribution unlimited

Reproduced by
**NATIONAL TECHNICAL
INFORMATION SERVICE**
U.S. Department of Commerce
Springfield, VA 22151



**Air Force Materials Laboratory
Air Force Systems Command
Wright-Patterson Air Force Base, Ohio**

NOTICE

When Government drawings, specifications, or other data are used for any purpose other than in connection with a definitely related Government procurement operation, the United States Government thereby incurs no responsibility nor any obligation whatsoever; and the fact that the government may have formulated, furnished, or in any way supplied the said drawings, specifications, or other data, is not to be regarded by implication or otherwise as in any manner licensing the holder or any other person or corporation, or conveying any rights or permission to manufacture, use, or sell any patented invention that may in any way be related thereto.



Copies of this report should not be returned unless return is required by security considerations, contractual obligations, or notice on a specific document.

DOCUMENT CONTROL DATA - R&D		
<i>(Security classification of title, body of abstract and indexing annotation must be entered when the overall report is classified)</i>		
1 ORIGINATING ACTIVITY (Corporate author)		2a REPORT SECURITY CLASSIFICATION
The University of Arizona Engineering Experiment Station Tucson, Arizona 85721		Unclassified
		2b GROUP
3 REPORT TITLE		
FINAL TECHNICAL REPORT, PART I - NEW TECHNIQUES IN NONDESTRUCTIVE TESTING (EXO-ELECTRON EMISSION PHASE)		
4 DESCRIPTIVE NOTES (Type of report and inclusive dates)		
Final Technical Report		
5 AUTHOR(S) (Last name, first name, initial)		
Stuart A. Hoenig		
6 REPORT DATE	7a TOTAL NO OF PAGES	7b NO OF PAGES
December 1971	35	
8a CONTRACT OR GRANT NO	9a ORIGINATOR'S REPORT NUMBER(S)	
F33615-68-C-1707	ARFA-No. 1244	
8b PROJECT NO	9b OTHER REPORT NUM(S) (Any other numbers referring to origin of this report)	
	AFML-TR-71-140	
10 AVAILABILITY LIMITATION NOTICES		
11 SUPPLEMENTARY NOTES		12 SPONSORING MILITARY ACTIVITY
		Air Force Materials Laboratory Wright-Patterson AFB, Ohio
13 ABSTRACT		
We have demonstrated that:		
<ol style="list-style-type: none"> 1. A direct connection exists between the fatigue damage in a metal and thermally induced post-fatigue exo-electron emission. This effect is due to the migration of vacancies to the surface. 2. Exo-electron emission can be used to measure fatigue in structures, and monitor annealing of quenched metals. We have followed the growth of "tearing" failures in various metals. We feel that the technique can be extended to detection and monitoring of fatigue crack growth. 3. Apparatus for applying these techniques to structures in-the-field has been designed and are being constructed and tested. 		

KEY WORDS	LINE A		LINE B		LINE C	
	ROLE	WT	ROLE	WT	ROLE	WT
Electron						
Fatigue						
Nondestructive Testing						
Cracking						
Structures						

INSTRUCTIONS

1. ORIGINATING ACTIVITY: Enter the name and address of the contractor, subcontractor, grantee, Department of Defense activity or other organization (corporate author) issuing the report.

2a. REPORT SECURITY CLASSIFICATION: Enter the overall security classification of the report. Indicate whether "Restricted Data" is included. Marking is to be in accordance with appropriate security regulations.

2b. GROUP: Automatic downgrading is specified in DoD Directive 5200.10 and Armed Forces Industrial Manual. Enter the group number. Also, when applicable, show that optional markings have been used for Group 3 and Group 4 as authorized.

3. REPORT TITLE: Enter the complete report title in all capital letters. Titles in all cases should be unclassified. If a meaningful title cannot be selected without classification, show title classification in all capitals in parentheses immediately following the title.

4. DESCRIPTIVE NOTES: If appropriate, enter the type of report, e.g., Interim, progress, summary, annual, or final. Give the inclusive dates when a specific reporting period is covered.

5. AUTHOR(S): Enter the name(s) of author(s) as shown on or in the report. Enter last name, first name, middle initial. If military, show rank and branch of service. The name of the principal author is an absolute minimum requirement.

6. REPORT DATE: Enter the date of the report as day, month, year, or month, year. If more than one date appears on the report, use date of publication.

7a. TOTAL NUMBER OF PAGES: The total page count should follow normal pagination procedures, i.e., enter the number of pages containing information.

7b. NUMBER OF REFERENCES: Enter the total number of references cited in the report.

8a. CONTRACT OR GRANT NUMBER: If appropriate, enter the applicable number of the contract or grant under which the report was written.

8b, c, & d. PROJECT NUMBER: Enter the appropriate military department identification, such as project number, subproject number, system number, task number, etc.

9a. ORIGINATOR'S REPORT NUMBER(S): Enter the official report number by which the document will be identified and controlled by the originating activity. This number must be unique to this report.

9b. OTHER REPORT NUMBER(S): If the report has been assigned any other report number (either by the originator or by the sponsor), also enter this number(s).

10. AVAILABILITY/LIMITATION NOTICES: Enter any limitations on further dissemination of the report, other than those

imposed by security classification, using standard statements such as:

- (1) "Qualified requesters may obtain copies of this report from DDC."
- (2) "Foreign announcement and dissemination of this report by DDC is not authorized."
- (3) "U. S. Government agencies may obtain copies of this report directly from DDC. Other qualified DDC users shall request through _____."
- (4) "U. S. military agencies may obtain copies of this report directly from DDC. Other qualified users shall request through _____."
- (5) "All distribution of this report is controlled. Qualified DDC users shall request through _____."

If the report has been furnished to the Office of Technical Services, Department of Commerce, for sale to the public, indicate this fact and enter the price, if known.

11. SUPPLEMENTARY NOTES: Use for additional explanatory notes.

12. SPONSORING MILITARY ACTIVITY: Enter the name of the departmental project office or laboratory sponsoring (paying for) the research and development. Include address.

13. ABSTRACT: Enter an abstract giving a brief and factual summary of the document indicative of the report, even though it may also appear elsewhere in the body of the technical report. If additional space is required, a continuation sheet shall be attached.

It is highly desirable that the abstract of classified reports be unclassified. Each paragraph of the abstract shall end with an indication of the military security classification of the information in the paragraph, represented as (TS), (S), (C), or (U).

There is no limitation on the length of the abstract. However, the suggested length is from 150 to 225 words.

14. KEY WORDS: Key words are technically meaningful terms or short phrases that characterize a report and may be used as index entries for cataloging the report. Key words must be selected so that no security classification is required. Identifiers, such as equipment model designation, trade name, military project code name, geographic location, may be used as key words but will be followed by an indication of technical context. The assignment of lines, rules, and weights is optional.

AFML-TR-71-140

NEW TECHNIQUES IN NONDESTRUCTIVE TESTING
(EXO-ELECTRON EMISSION PHASE)

Dr. Stuart A. Hoenig
The University of Arizona

Approved for public release; distribution unlimited.

ic

FOREWORD

This report was prepared by Stuart A. Hoenig, William A. Ott, Mir Turab Ali, and Thomas A. Russell, of the Electrical Engineering Department of The University of Arizona. The program was supported by the Advanced Research Projects Agency (ARPA Order 1244, Program Code No. 8D10) and monitored by the Air Force Materials Laboratory under Contract F33615-68-C-1707. Capt. J. W. Bohlen (AFML/LLN, Wright-Patterson Air Force Base, Ohio 45433), Project Monitor, suggested the scanning experiment described in the section on fatigue evaluation.

The authors wish to thank Dr. George Martin, McDonnell-Douglas Astronautics Company, Santa Monica, California; Dr. R. H. Chambers and R. M. Emrick, Physics Department, The University of Arizona, for their suggestions and advice. Mr. C. Savitz designed and built much of the experimental apparatus. His help was invaluable.

This technical report has been reviewed and is approved.

THOMAS D. COOPER
Chief, Processing and
Nondestructive Testing Branch
Metals and Ceramics Division

ABSTRACT

We have demonstrated that:

1. *A direct connection exists between the fatigue damage in a metal and thermally induced post-fatigue exo-electron emission. This effect is due to the migration of vacancies to the surface.*
2. *Exo-electron emission can be used to measure fatigue in structures, and monitor annealing of quenched metals. We have followed the growth of "tearing cracks" in various metals. We feel that the technique can be extended to detection and monitoring of fatigue crack growth.*
3. *Apparatus for applying these techniques to structures in-the-field has been designed and is being constructed and tested.*

TABLE OF CONTENTS

<u>Section</u>	<u>Page</u>
I. INTRODUCTION	1
II. EXPERIMENTS AND RESULTS	3
A. OBJECTIVE 1	3
B. OBJECTIVE 2	6
C. OBJECTIVE 3	9
D. OBJECTIVE 4	10
III. CONCLUSIONS	12
OBJECTIVES OF THE PROGRAM	12
REFERENCES	13
PUBLICATIONS	14
APPENDIX I - ILLUSTRATIONS	15

LIST OF ILLUSTRATIONS

Figure

1. Vacuum Fatiguing Assembly and Associated Electronics.
2. Rotary to Oscillatory Motion Converter.
3. Etching Apparatus and Typical Specimen.
4. Exo-electron Current vs. Time and Fatigue Level (nickel 205).
5. Exo-electron Current vs. Time and Fatigue Level (nickel 205).
6. Integrated Exo-electron Current vs. Percent of Fatigue Life (nickel 205).
7. Exo-electron Annealing System.
8. Exo-electron Current vs. Time at Various Temperature, With and Without Quenching (isochronal annealing).
9. ΔI (slow current rise) vs. Temperature (isochronal annealing).
10. Exo-electron Fatigue Test Specimen.
11. Exo-electron Heating and Electrical Systems.
12. Exo-electron Current vs. Time and Fatigue Level (1100-0 aluminum).
13. Exo-electron Current vs. Time and Fatigue Level (1100-0 aluminum).
14. Exo-electron Current vs. Time and Fatigue Level (7075-T6 aluminum).
15. Exo-electron Current vs. Length and Fatigue Level (7075-T6 aluminum).
16. Placket Detector.
17. Test Fixture and Specimen.
18. Exo-electron Current vs. Crack Growth (aluminum).
19. Exo-electron Current vs. Crack Growth (hot rolled steel).
20. Exo-electron Current vs. Crack Growth (OFHC copper).

SECTION I

INTRODUCTION

The problem of fatigue and subsequent failure exists in all structures. The situation in military aircraft is more critical because high strength, crack sensitive materials must be used and factors of safety are restricted because of weight limitations. A need exists for a method of measuring the fatigue level of various structural elements to determine their remaining safe-life. A major factor in this determination is the detection of cracks which have developed during the fatigue exposure. Modern aircraft materials are well known to be crack sensitive. This in turn requires a crack detection system that can operate on cracks that cannot be detected visually.

The approach proposed by the authors involved observation of the exo-electron emission from fatigued and cracked materials. A study of the literature and some experiments under an earlier program for the AEC, indicated that while the mechanism of exo-electron emission was unknown, there were some phenomena that certainly induced exo-electron emission. Among these were:

1. *Plastic deformation*
2. *Grinding or abrasion*
3. *Exposure to ionizing radiation*
4. *Quenching*
5. *Phase change*
6. *Chemisorption*
7. *Oxidation*
8. *Corrosion*
9. *Fatigue*

A list of references appears on page 13 of this report.

It appeared that any process that disturbed the surface of a metal could induce exo-electron emission. The mechanism of emission might involve either the existence of "F" centers in surface oxides, or the disturbance of the surface potential barrier by vacancy migration. We suggested that if the vacancy migration mechanism was correct, a fatigue and crack detection system might make use of exo-electron emission. The mechanism depended upon the known fact that

fatigue generates a complex network of vacancies and dislocations. Some of the vacancies diffuse to the surface during the fatigue cycle and induce exo-electron emission. However, the majority of vacancies will be sessile at room temperature. It follows then that by heating the specimen slightly it should be possible to induce a fraction of the sessile vacancies to migrate to the surface. The resultant exo-electron emission would be a measure of the fatigue level of the specimen. This test could be applied after the aircraft had landed.

The ARPA funded program had as its objectives:

1. *A demonstration that exo-electron emission was related to vacancy migration and fatigue;*
2. *That exo-electron emission could be used for post-fatigue measurement of fatigue level in ambient air;*
3. *That apparatus for laboratory and field use of this technique could be designed and built;*
4. *After the program had been in effect for one year the objective of detecting fatigue crack initiation and growth was added. Here we hoped that the extensive dislocation motion and vacancy formation that precedes crack initiation would induce exo-electron emission.*

The experimental approach involved several different experiments. The first was designed to determine if post-fatigue exo-electron emission could be observed in ultra high vacuum without ambient light. This would help settle the question of an "F" center versus a vacancy mechanism. When the first series of tests were completed the emphasis would be shifted to studies in air, on full size test coupons of various alloys and tempers to determine if we could indeed make a post-fatigue measurement of fatigue level.

The third objective was to be the development of hardware for application of this technique to actual aircraft structures. The work on crack detection was intended to be part of this third objective.

SECTION II

EXPERIMENTS AND RESULTS

A. OBJECTIVE 1

To investigate Objective 1 we first designed and built an ultra high vacuum test system. This system including the electrical components is shown schematically in Figure 1. The system allowed us to fatigue test specimens in vacuum by alternating torsion. The fatigue mechanism was driven by an external motor through a vacuum bellows seal. The rotary motion was changed to an oscillatory motion by a system of gears (Figure 2) inside the vacuum system.

The electrical system, for detection of exo-electron emission (EEE), was assigned to operate either during or after the fatigue cycling process. The noise level was about 10^{-15} amps which allowed detection of currents above the 10^{-14} amp level. For some experiments a Keithly 417 picoammeter was used. For other studies a Burr-Brown field effect transistor (FET) operational amplifier was coupled to a transistor amplifier. All data was recorded on a Heath Company chart recorder.

The specimens were metal wires (nickel 205) initially 0.032" in diameter with an etched gauge section as shown in Figure 3. Typical experiments involved:

1. *Fatiguing an annealed specimen under UHV (10^{-8} torr) conditions to some fraction of its previously determined life.*
2. *Observation of the exo-electron emission during the fatigue cycling.*
3. *Post fatigue heating (in the vacuum system) to determine if the post fatigue exo-electron emission was related to the fatigue level that had been attained before the heating cycle began.*

Results of these vacuum studies may be described as follows: During the fatigue process exo-electron emission at the 10^{-12} amp level was observed. Each time the wire was twisted a burst of electrons was recorded. The currents were small and the interference from electrons emitted by the mechanical gearing made it difficult to follow changes in current level. Other investigators [1] have observed exo-electron emission during fatigue. The current first increases with each cycle and then decreases again. This may be due

to work hardening, making it more difficult for dislocations to move. We do not feel that measurement of exo-electron emission during fatigue was as useful as post-fatigue testing, and this study was terminated.

The studies of EEE after fatigue involved heating the specimen to some fixed temperature in the vacuum system (at 10^{-8} torr) and following the EEE. The results of typical tests on several specimens, fatigued to various levels, are shown in Figures 4 and 5. We note that there is a clear relation between fatigue and post-fatigue EEE. This data was obtained without the ultraviolet light used in later studies, and temperatures required for significant exo-electron emission were quite high (800° - 1000°C).

We feel that this data demonstrates that EEE is not dependent upon the ambient atmosphere or the presence of ambient light.* These conditions may increase the effective EEE current, but they are not necessary if EEE is to be observed.

In examining the data of Figure 4 and 5 we felt that a correlation existed between the specimen fatigue level before heating and the area under the current-time curve generated when the specimen was heated. The necessary integration was done graphically and the results are shown for our nickel specimens in Figure 6. The correlation is fair up to about the 55 percent level where the exo-electron current begins to decay. We suggest that this represents the level at which the vacancies and dislocations begin to pin one another and diffusion is impeded. This suggests that further heating, to above 1000°C , would induce exo-electron emission at high fatigue levels. There is some evidence for this but it was not practical to heat nickel above 1000°C in our vacuum apparatus.

Having determined that a relationship existed between fatigue and post fatigue EEE, we decided to look into the phenomena by relating fatigue damage to post fatigue EEE. One of the prevailing theories [2,3], suggested that fatigue produces a variety of defects including metal vacancies. Upon heating, these vacancies diffuse to the surface and induce EEE.

Two questions arise here, first, why do vacancies diffuse to the surface and second, why does their arrival at the surface induce exo-electron emission? The first phenomena, diffusion, is spontaneous if the vacancy mobility is high enough, because vacancy migration to the

*Above 800°C the nickel specimen became incandescent but there was no other external illumination.

surface reduces the Gibbs Function of the system. The mechanism by which a vacancy, in arriving at the surface, induces exo-electron emission is a matter of speculation [3]. We suggest that a reduction occurs in the local work function when the vacancy arrives at the surface. This in turn allows some of the electrons at the Fermi Energy level to escape. The effect of surface disturbance processes in lowering the work function of photo emitters is well known and we propose that the process here is much the same.

The effects of light in terms of an absolute increase in the exo-electron emission are still more obscure. If it were a case of simple photo-emission the effective signal to noise ratio of the exo-electron emission would not be affected because of the increased background photo electric current. Since an actual increase in S/N ratio is observed, we must postulate that light somehow aids the vacancy-exo-electron mechanism. The final resolution of this question must await experiments on ultra clean surfaces using a vacuum UV spectrometer.

To gain a preliminary understanding of the effect of vacancy migration we decided to quench vacancies into metals and study the EEE that was observed when the specimen was heated to induce vacancy migration. Experiments of this type had been done with aluminum by Brotzen and his associates [4], with a crude Gieger counter technique. They observed exo-electron emission during room temperature annealing after various quenching sequences. They correlated their data with a vacancy migration model and the resistivity data of von Voss and Brotzen [5].

Exo-Electron Emission and Annealing Processes: Physicists have worked for many years on the recovery phenomenon in quenched metals. The number and type of vacancies produced are well known [6]. The major problem in following annealing processes has been that the migration of vacancies was only observable in terms of secondary effects, i.e., electrical resistance or micro hardness.

We have used metal wires to observe exo-electron emission, during vacancy migration, with the apparatus shown in Figure 7. For this experiment the 0.010 inch diameter wire specimens could be heated by AC current via the transformer. To quench the wire the heating current was turned off and the wire was flooded with liquid nitrogen.

To investigate the effects of quenching an annealed wire (procedure of Ref. 7 was used) and a wire quenched from 1275°C were annealed isochronically (6 minutes at each temperature). The observed EEE current is shown in Figure 8. Each time the temperature was increased there was a sudden drop in the EEE current followed by a slow increase.

The sudden drop in exo-electron current is difficult to understand at this time. It may be characteristic of platinum since Claytor et al., did not observe it during annealing of aluminum after plastic deformation [8]. We feel that it is more significant to look at the slow increase observed during annealing of the quenched wire. We suggest that the slow increase observed with the quenched wire from 250 to 400°C is due to quenched-in vacancies coming to the surface. To compare this data to that of other workers, we took the difference current ΔI as shown in Figure 8; Δt was always taken as 300 seconds. ΔI was the "slow" change in current during this interval.

In Figure 9 we show ΔI the change in current during the slow rise period versus T the annealing temperature. The annealing data of Schumacher [9], is shown for comparison. The agreement seems to be excellent. We note that Schumacher's data were obtained by the very difficult resistance monitoring technique. It is clear from Figure 9 that we can follow the processes of vacancy migration with exo-electron emission. Similar data are being obtained for nickel and gold. By working in a vacuum and radiation quenching, we should be able to investigate ferrous materials. Future studies of isothermal annealing will be done when our temperature control system is completed. We are most interested in the sudden drop in current which is so prominent at 200°C in Figure 8. There may be a direct connection between this sudden change and the well known phenomena of flash desorption [10]. This may well be a topic for future investigation.

Returning for the moment to Figure 9, we feel that these experiments are most significant for two other reasons; first, they demonstrate a direct connection between a known vacancy phenomena and exo-electron emission. Second, we can expect to calibrate the system in terms of exo-electron emission as a function of the number of vacancies which reach the surface.

B. OBJECTIVE 2

In order to develop EEE into a practical tool for studying fatigued structures, we decided to change to larger specimens which would be comparable to those used in industry. It was decided that these studies would have to be done in ambient air if the EEE technique was to become field-useable.

The specimen shape is shown in Figure 10. The material chosen for study was aluminum (1100-0 and 7075-T6). The aluminum specimens were annealed and in the case of 7075-T6 heat treated* into the proper conditions.

The annealed and polished specimens were fatigued in a resonant machine during the early part of the program and a Vishay VSP-150 plate machine in the latter period.

To establish a mean lifetime we ran 10 specimens to failure. For the 1100-0 material the average number of cycles was 147,000 with a maximum excursion of ± 15 percent. The next set of specimens were run to some fraction, 0 percent, 20 percent, 40 percent, 60 percent, and 80 percent of their expected life and tested for exo-electron emission.

The test apparatus and the electrical circuit is shown in Figure 11. The ultraviolet light source seems to increase the exo-electron current by about a factor of 50. The photoelectric current is a constant background level which does not present any problem in interpreting the data. Figures 12 and 13 show the exo-electron current as a function of time for 1100-0 specimens at various fatigue levels. There is a clear, distinct relation between fatigue and exo-electron emission for 1100-0 aluminum. We wish to emphasize that these fatiguing and exo-electron studies were done in ambient air. The temperature after 8 minutes was 90°C, far below the temperature where metallurgical changes would occur.

Similar data on 7075-T6 aluminum is shown in Figure 14. There was more scatter in the total cycles-to-failure-tests. The average lifetime (10 specimens) was 46,000 cycles ± 18 percent. In Figure 14 we see again that the exo-electron emission can be correlated with the fatigue history of the specimen. However, we note that emission from the 75 percent specimen was below the 0 percent specimen until a temperature of 160°C was reached. This suggests that at high fatigue

*After heat treating the specimens were chemically milled to remove scratches and we emphasize that this procedure is most important for obtaining uniform fatigue life and consistent EEE data. This is not an accident; there is an enormous body of literature which demonstrates that scratches and surface defects act as stress raisers. These stress raising defects reduce fatigue life and it is impossible to obtain consistent fatigue life data without controlling specimen surface finish [6,7,12,13]. In view of the close relations between fatigue and EEE we would expect that consistent EEE would only be obtained on surfaces with controlled finishes.

levels a higher temperature is needed to induce vacancy motion. A similar effect was observed with nickel wires and is shown in Figure 6.

Notice in Figure 14 that the 25 percent and 50 percent curves overlap. This may be scatter in fatigue life itself. Alcoa data [11] indicates that at best, 7075-T6 fatigue life varies from 1,000 to 14,000 cycles around a central value of 4,000 cycles (80,000 psi load). This suggests that at the 80kpsi load level a specimen might be at the 25 percent level after as little as 250 cycles or as much as 3,500 cycles. If we assume the midpoint value of the scatter band (4,000 cycles) to be the "fatigue life," at 80kpsi we must run a 25 percent specimen 1,000 cycles. However, in view of the scatter of fatigue life, the specimen might be only a 7 percent specimen. Under these circumstances, it is more reasonable to run a specimen say "N" cycles test it and then run it to failure, which might occur at a total of say "Q" cycles. Then we can say that when the specimen was tested it was at the $N/Q \times 100$ fatigue level. Unfortunately this situation was not appreciated until after the program was over so the data of Figure 14 must remain somewhat ambiguous.

A few specimens were run to failure after testing to determine if the exo-electron test cycle was inducing any major metallurgical changes in the specimens. In terms of the accuracy of our fatigue life data there was no evidence that the specimen had changed, i.e., a predicted 40 percent specimen was an actual 40 percent specimen ± 18 percent regardless of its exo-electron test history. This is to be expected, during the test we anneal out only a small fraction of the total fatigue damage.

We feel that this series of tests demonstrated the capability of EEE for fatigue evaluation of coupons with a known fatigue history. However, for actual structures, no standards of fatigue may be available and we investigated a different test technique which involved scanning the heat source and exo-electron collector along the specimen, (Figure 11). This allowed a comparison of a relatively unfatigued area with a fatigued area, on a single specimen. In Figure 15 we show some recent results obtained by scanning along the specimens. It is apparent that we can find the fatigued area and evaluate the amount of fatigue that is present. The measurement can be repeated as shown by the curves marked 2nd run. We notice in Figure 15 that the exo-electron level, along the entire specimen, goes up with fatigue level. This change of level and the second peak observed in the higher fatigue specimens is observed consistently and we have no theory for this at the moment. We suspect it is an artifact introduced by the use of our particular specimen shape in the Vishay fatigue machine. Investigations into this question will begin when our induction heater is finished.

We feel that this work has demonstrated the capability of EEE to detect fatigued areas and determine the fatigue level. This completes Objective 2 at least for aluminum.

C. OBJECTIVE 3

The major problems in field applications of FEE are: first, introducing the necessary thermal energy and, second, separating the emission from scratches and cracks from that due to fatigue.

Heating Techniques: After much study and experimentation with hot gas systems, intense light sources and electrical resistance heating, we developed a placket detector for fixed applications and an induction heater for scanning.

Placket System: The placket detector combines in a single unit a squib heat source, a Glaubers Salt heat buffer, a battery driven UV source and a self-developing electron sensitive film. The system is shown in Figure 16. The diameter of the placket is about 2 inches, to permit its application in restricted areas.

The operational sequence would involve:

1. *Fastening the placket to a fatigued structure, turning on the UV light and hooking up the 45 volt battery.*
2. *Firing the squib. This releases a very short but intense thermal pulse which lasts only a few seconds. The Glaubers Salt dissociates according to the formula:*

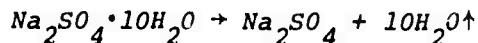

and the resultant steam circulates in the sealed container. As the placket cools below 100°C the reaction goes backwards releasing the heat previously adsorbed. The effect of this buffer reaction keeps the structure from being heated above about 100°C and spreads the heating cycle over about 8 minutes.

3. *Exo-electrons are collected on the film, which is of the Polaroid self-developing variety. The blackening of the film provides a direct read-out of the fatigue of the structure. The structure has only been heated to some 150°C for 2 minutes so no major metallurgical changes have occurred. The placket system is satisfactory for one-shot tests but it does require a body of test data, on the same structure, for evaluation.*

Scanning System: The scanning technique makes use of an induction heater. Induction heating has a number of advantages. Induction heaters are usually available at military bases. Induction heating is efficient because the heat is developed in the specimen material itself without the losses that occur due to metallic reflection when radiant heat sources are used. Induction heating also avoids the problems of hot gas heaters where the gas flow interferes with electron collection. Induction heating heads are available in a variety of diameters and operate at selectable frequencies. This makes them suitable for heating structures of various sizes and thicknesses. The fact that the induction heating head itself remains cool allows the heat source and exo-electron collector to scan along a structure to find fatigued areas.

D. OBJECTIVE 4

The fatigue experiments reported above were performed on idealized, polished metal surfaces to remove any variables which might depend upon surface condition. There is no question that smooth surfaces provide the best opportunity for uniform fatigue life and an unequivocal EEE fatigue correlation. However, we recognize that in actual aircraft it is not yet common to polish metal surfaces in fatigue critical areas. In fact, it may never be possible to polish all areas where fatigue failure might occur. In view of this problem, we began a study of the detection of surfaces, scratches, cracks and other defects. The objective would be a demonstration that we could detect scratches and cracks by scanning for EEE with an ultraviolet light without heating the specimen. A subsequent scan with heating would yield a higher EEE due to fatigue and scratches, the difference would then be due to fatigue alone.

For this demonstration we built a simple tensile machine around an automobile jack. The machine and the specimen shape are shown in Figure 17. By pumping the jack we could induce a crack or tear to start at the end of the saw cut and propagate through the material.

We expected that the EEE would increase when a crack or tear opened and that crack growth could be monitored by EEE without heating. This was indeed the case, and typical data on aluminum, steel, and copper are shown in Figures 18, 19, and 20. We feel that this data, obtained with the crudest apparatus, demonstrates that a significant change in exo-electron emission occurs when there is sufficient plastic deformation for a tear to appear. Tears as small as 0.1 mm in length were observable by this technique. This suggests that a similar capability will exist with fatigue cracks but this has not yet been demonstrated.

The major question is, can we detect microscopic fatigue cracks in a structure that has the normal scratches associated with industrial manufacturing? There is some hope for this on the basis that the emission from scratches may be different from that due to fatigue concentrations and microcracks due to fatigue. This difference depends upon the fact that scratches involve little or no slip while fatigue cracking is a highly slip dependent process [12,13].

We propose to scan scratched coupons without heating to detect the scratch pattern. After fatiguing the coupon will be scanned again with and without heating to try to resolve fatigued areas and fatigue cracks.

To show that it is possible to separate scratch effects from fatigue induced EEE, we have begun a test program. For initial studies 10 identical 7075-T6 specimens were fatigued to the same level and then 8 of them were scratched or abraded in various areas. The specimens were scanned without heating and then scanned again with induction heating.

The tests are not yet complete, but the indications are that scratches can be separated from fatigue by EEE techniques if the scratches are not too extensive in area or in depth. The "tolerable" scratch condition in terms of using EEE to detect fatigue will have to be determined by further testing.

SECTION III

CONCLUSIONS

OBJECTIVES OF THE PROGRAM

1. *A demonstration that exo-electron emission was related to vacancy migration and fatigue;*
2. *That exo-electron emission could be used for post-fatigue measurement of fatigue level in ambient air;*
3. *That apparatus for laboratory and field use of this technique could be designed and built;*
4. *After the program had been in effect for one year the objective of detecting fatigue crack initiation and growth was added. Here we hoped that the extensive dislocation motion and vacancy formation that precedes crack initiation would induce exo-electron emission.*

Objectives 1 and 2, have been essentially achieved at least for aluminum. Objective 3 has been partially achieved. The final development of apparatus for field analysis of structural fatigue will require at least one year of further study. The direction of this work is quite clear; the effort should include testing and calibration studies on full scale structural parts. Achievement of Objective 4 was hampered by the lack of a tensile fatigue machine for generation of fatigue cracks. The author was able to spend August 16-20 at Wright-Patterson Air Force Base through the courtesy of Dr. W. Kapp and Mr. V. Kearney. During this period fatigue tests were run on 2024-T4 aluminum at high stress levels where microcrack growth would be expected after some 0.1 percent of fatigue life. Exo-electron emission was observed to begin increasing almost as soon as cycling began and continue to increase as long as cycling continued. A very steep increase in current was observed just before failure.

Tests of this type will be continued at the University of Arizona with equipment now available. We would expect to demonstrate that the inception and growth of fatigue cracks can be detected by exo-electron emission.

REFERENCES

1. Krogstand, R., Moss, R., "Electron Emission During Metal Fatigue," Proc. Symp. Physics and NDT, September 28-30, 1965, Dayton, Ohio, pp. 9-21.
2. Mueller, H. J., "Exo-Electron Emission ...," AD 276-213, 1961.
3. Gruenberg, L., Brit. J. Applied Physics, 9, pp. 85-93, 1958.
4. Claytor, R. N., Gragg, J., Brotzen, F. R., J. Applied Physics, 37, No. 1, 149, 1966.
5. von Voss, W. D., Brotzen, F. R., J. Applied Physics, 30, No. 11, pp. 1639- , 1959.
6. Cotterill, R. M., et al., Editors, Lattice Defects in Quenched Metals, Academic Press, New York, 1965.
7. Jackson, J. J., Problems in Ultra Pure Materials, Vol. 1, E. Rexer, Editor, Akademie-Verlag, Berlin, 1966.
8. Claytor, R. N., Brotzen, F. R., J. Applied Physics, 36, No. 11, 1965.
9. Schumacher, D., et al., Phys. Stat. Sol., 25, 359, 1968.
10. Ehrlich, G., Advances in Catalysis, 14, 255, 1963.
11. Mehr, P. L., et al., "Alcoa Green Letter Alloy 7075-T73," Alcoa Research Lab., Figure 9, June, 1969.
12. Forsyth, P. J. E., The Physical Basis of Metal Fatigue, p. 174.
13. Madayag, A. F., Editor, Metal Fatigue, J. Wiley and Sons, New York, pp. 70, 81, 98, 321-323, 1969.

PUBLICATIONS

A report on this work was given at the 1971 ASTM Symposium, "Testing for Prediction of Material Performance in Structures and Components," April 21-23, 1971, Anaheim, California. A report was also given at the Department of the Army Symposium, on "Advanced NDT Techniques," Army Materials and Mechanics Research Center, Watertown, Massachusetts, June 1-3, 1971.

A paper on the quenching-annealing work will be submitted to the Journal of Applied Physics.

Mr. W. A. Ott received the MSEE degree in 1970. His thesis was entitled "Exo-electron Emission from Plastically Strained and Fatigue Damaged Materials," and is available from University Microfilms, Ann Arbor, Michigan. His work was supported by this program.

APPENDIX I
ILLUSTRATIONS

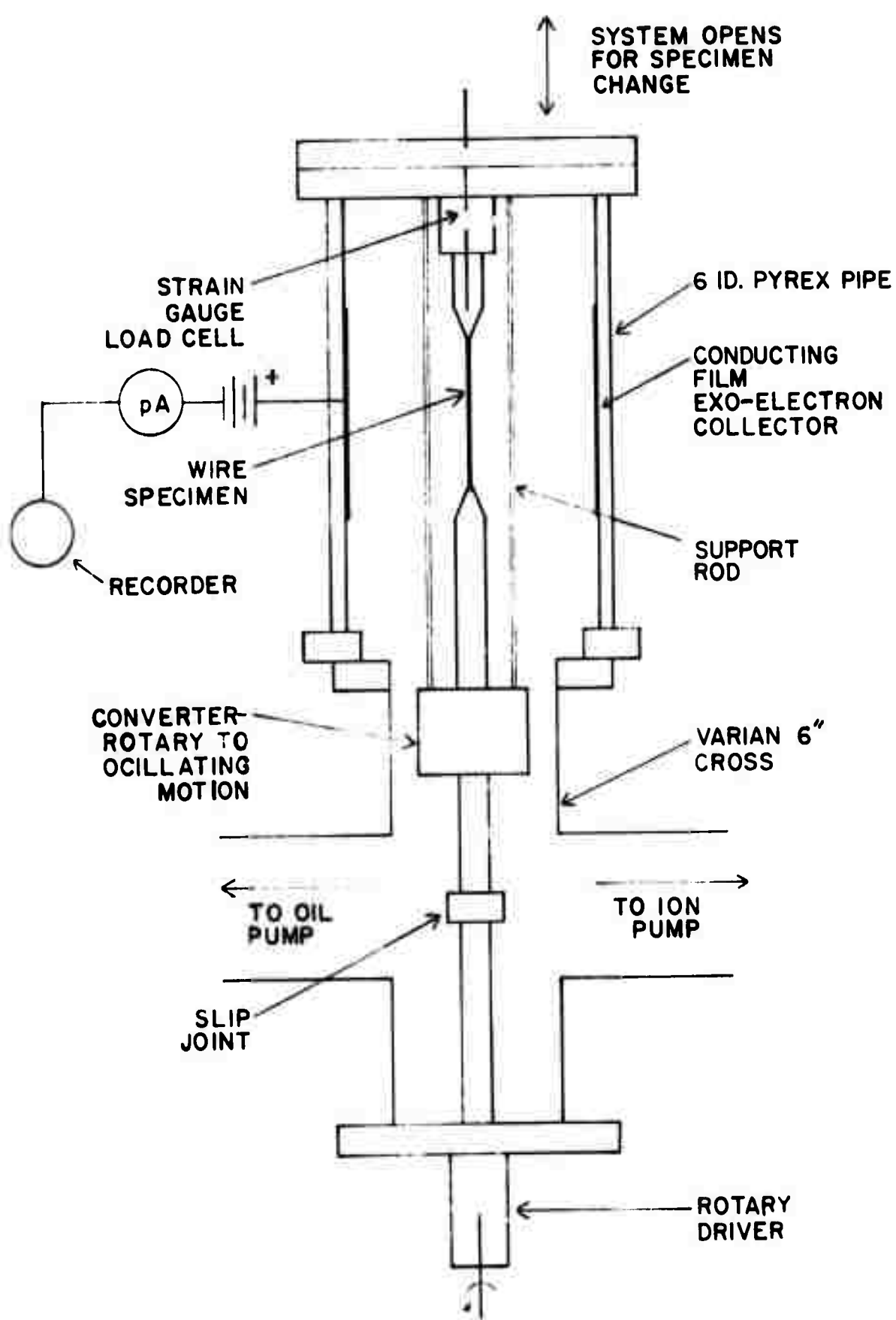

Figure 1. Vacuum Fatiguing Assembly and Associated Electronics.

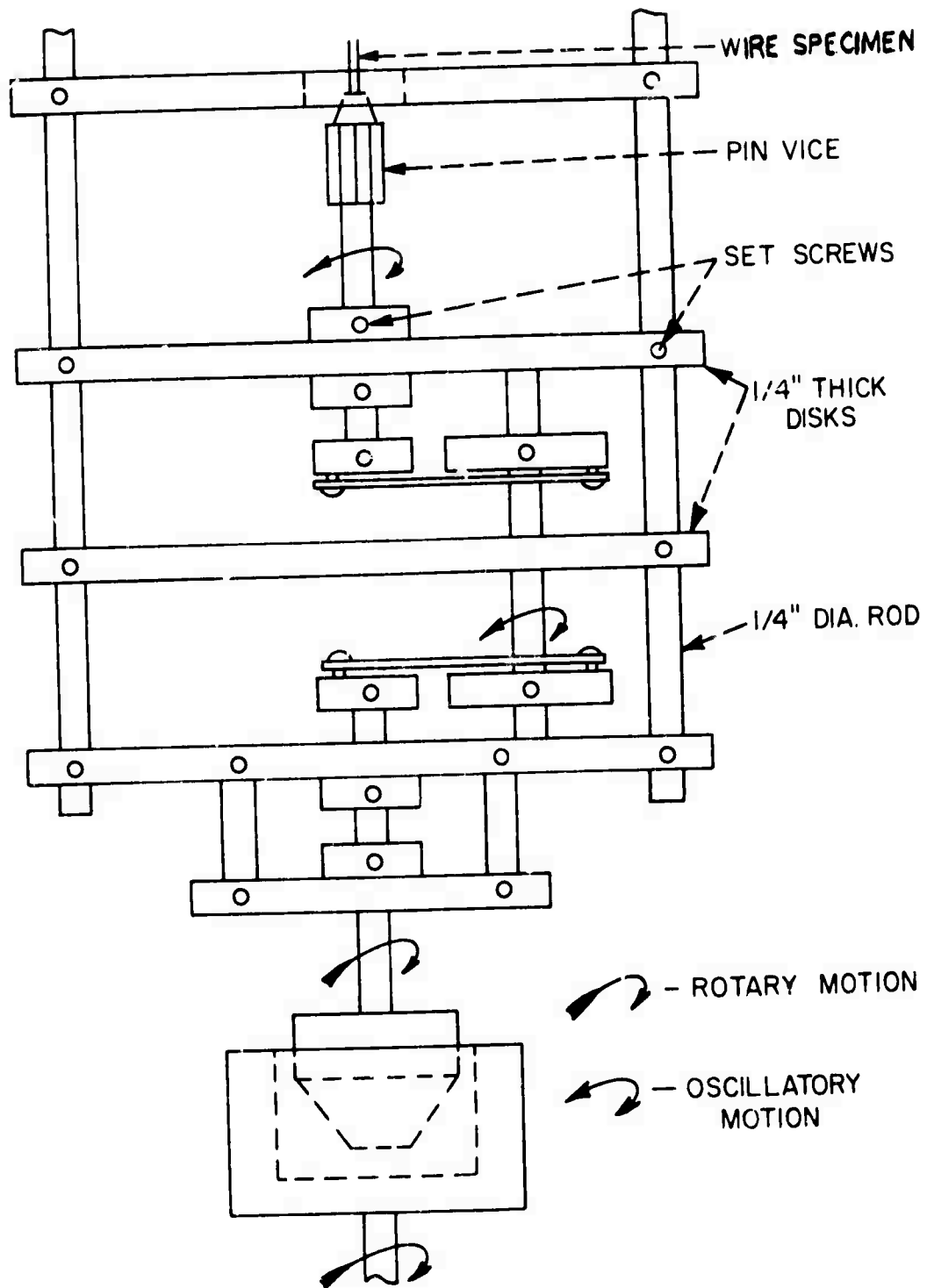

Figure 2. Rotary to Oscillatory Motion Converter.

V = 2.25 VOLTS
A = 1.00 AMP
T = 59 SEC

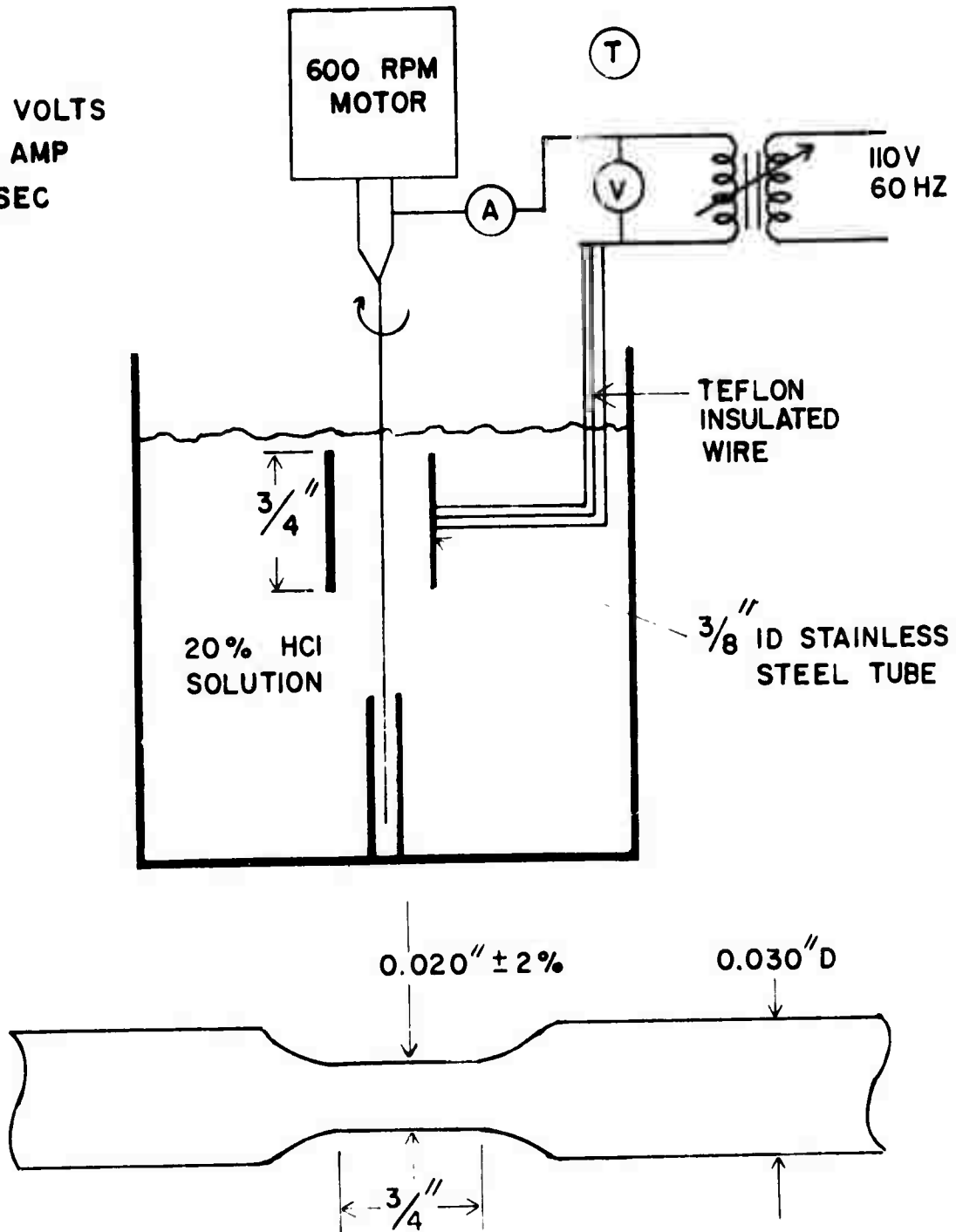

Figure 3. Etching Apparatus and Typical Specimen.

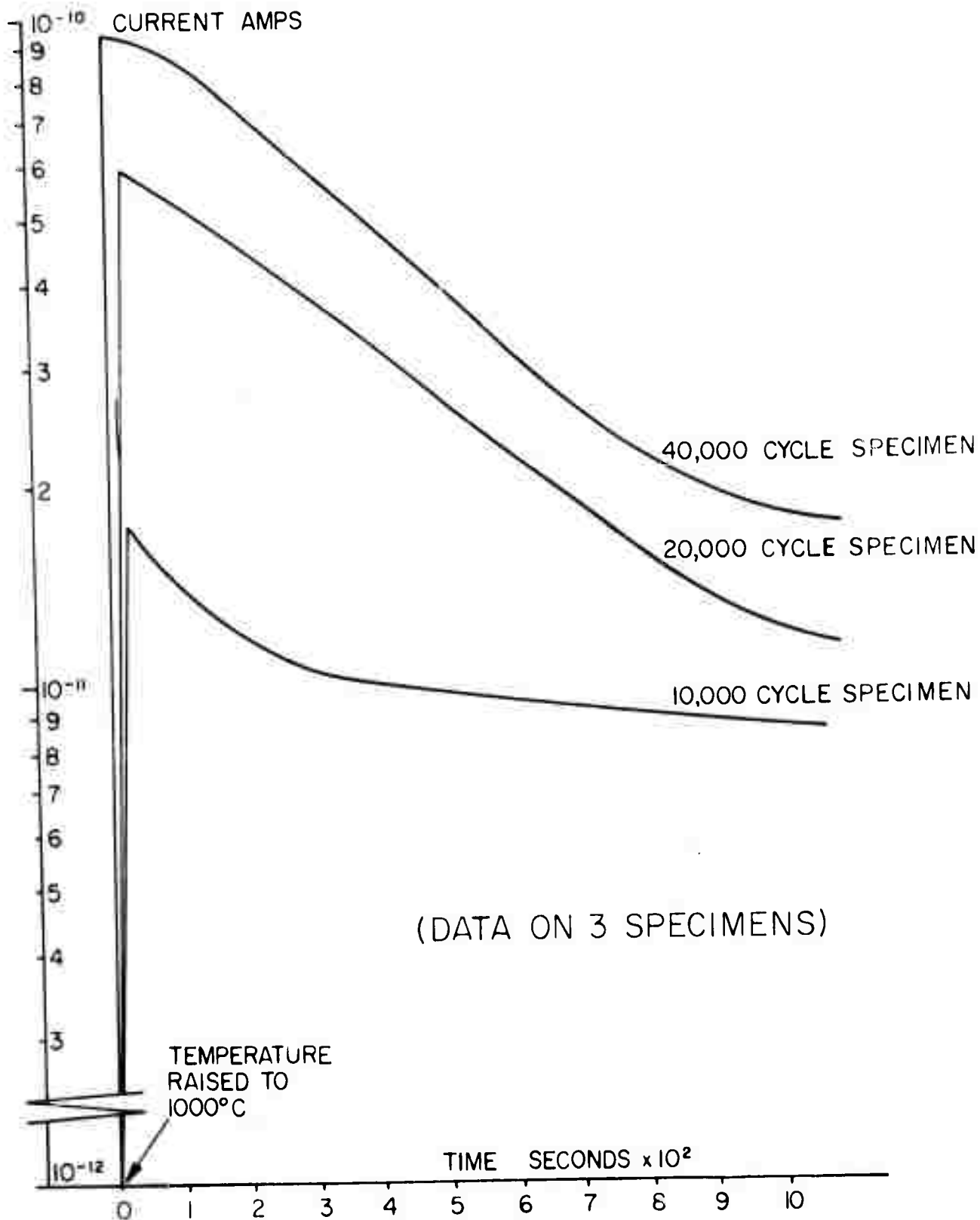

Figure 4. Exo-electron Current vs. Time and Fatigue Level (nickel 205).

EXO-ELECTRON
CURRENT
AMPS x 10⁻¹³

3.0—

2.0—

-20-

TEMP. RAISED
TO 800 °C

1.0—
0.9—
0.8—
0.7—
0.6—
0.5—
0.4—
0.3—
0.2—
0.1—
0

(DATA ON 3 SPECIMENS)

— 12,000 CYCLE SPECIMEN
- - - 4,000 CYCLE SPECIMEN
- · - · 0 CYCLE SPECIMEN

180

160

140

120

100

80

60

40

20

0

TIME (SEC)

Figure 5. Exo-electron Current vs. Time and Fatigue Level
(nickel 205).

DATA ON 14 SPECIMENS

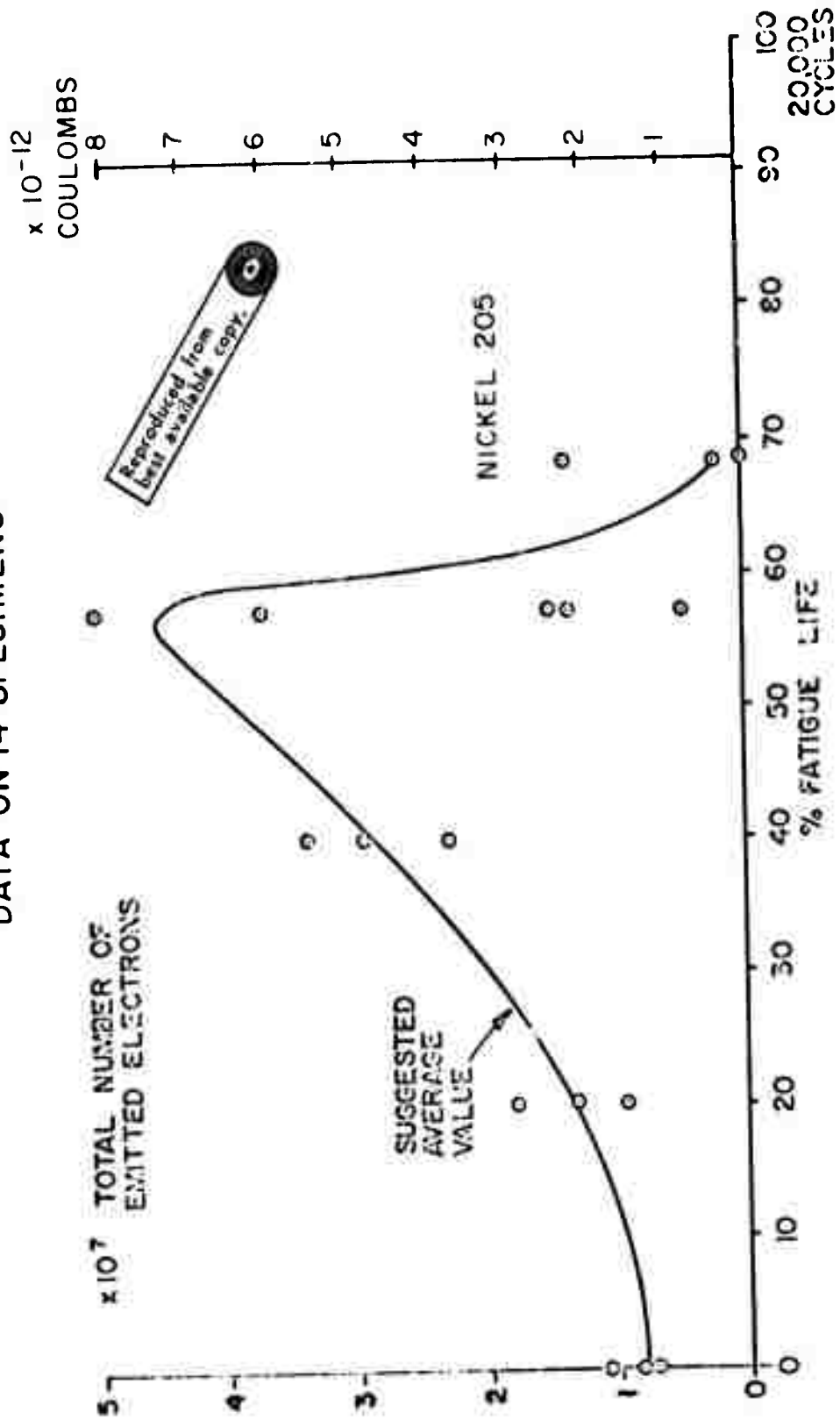

Figure 6. Integrated Exo-electron Current vs. Percent of Fatigue Life (nickel 205).

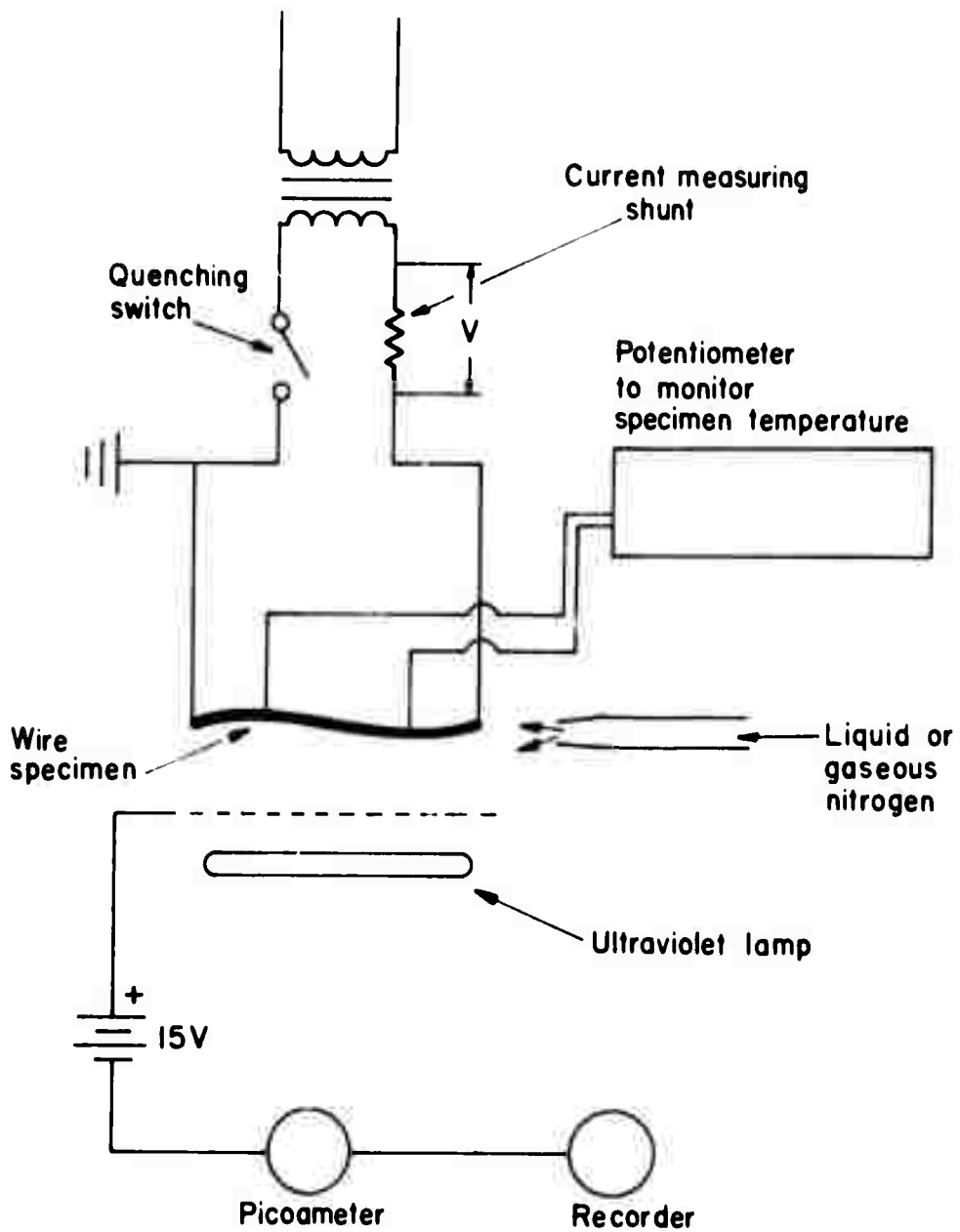

Figure 7. Exo-electron Annealing System.

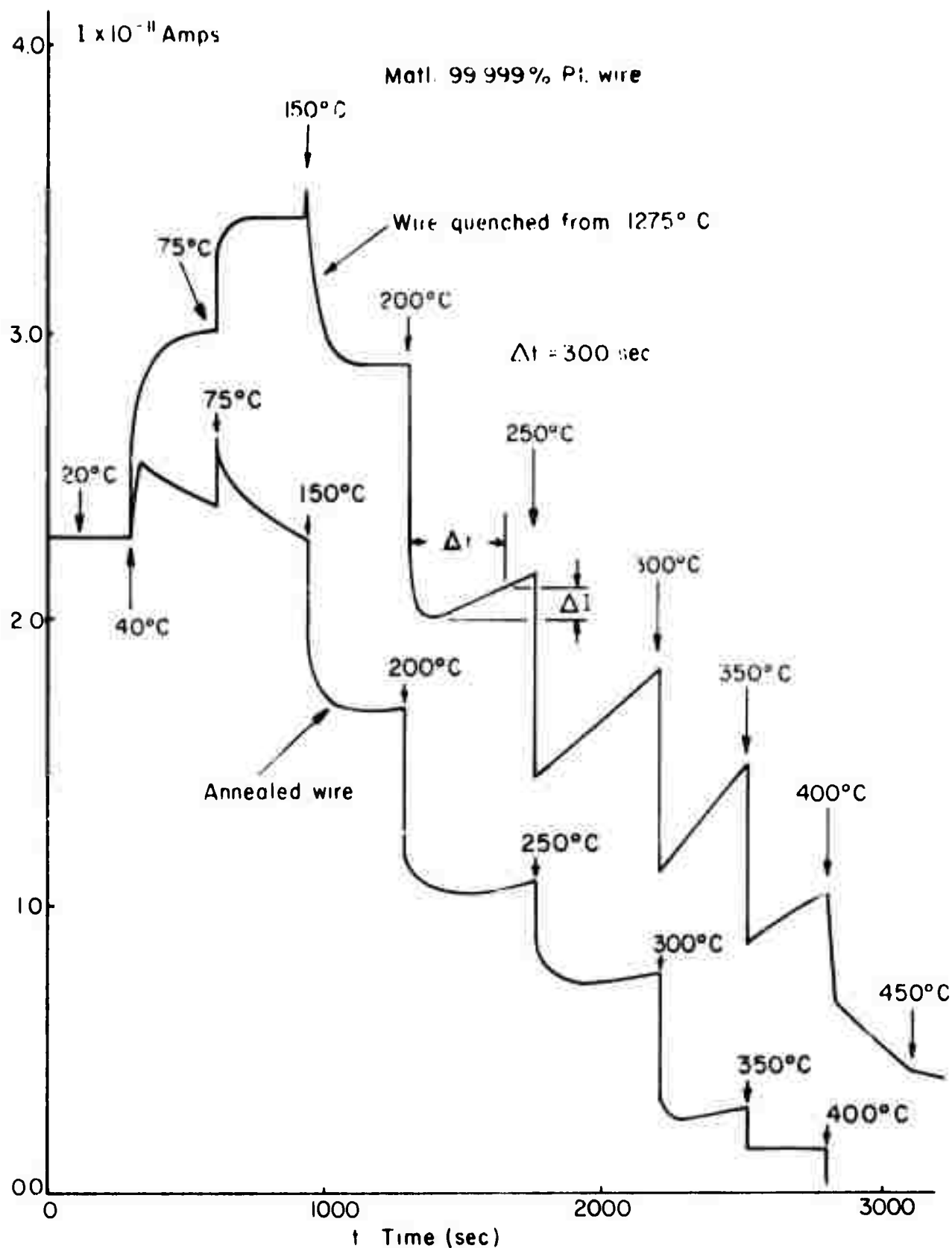

Figure 8. Exo-electron Current vs. Time at Various Temperature, With and Without Quenching (isochronal annealing).

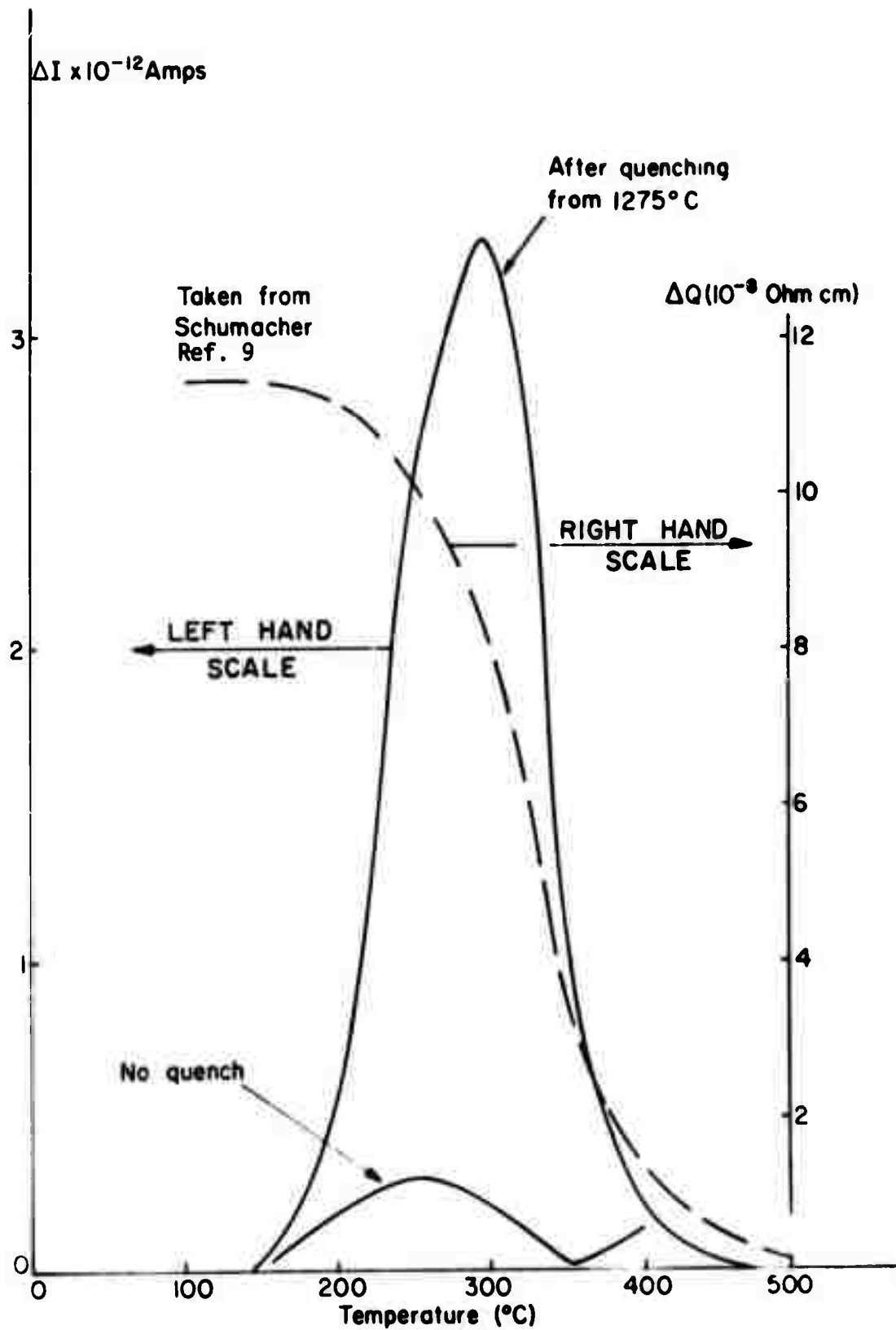

Figure 9. ΔI (slow current rise) vs. Temperature (isochronal annealing).

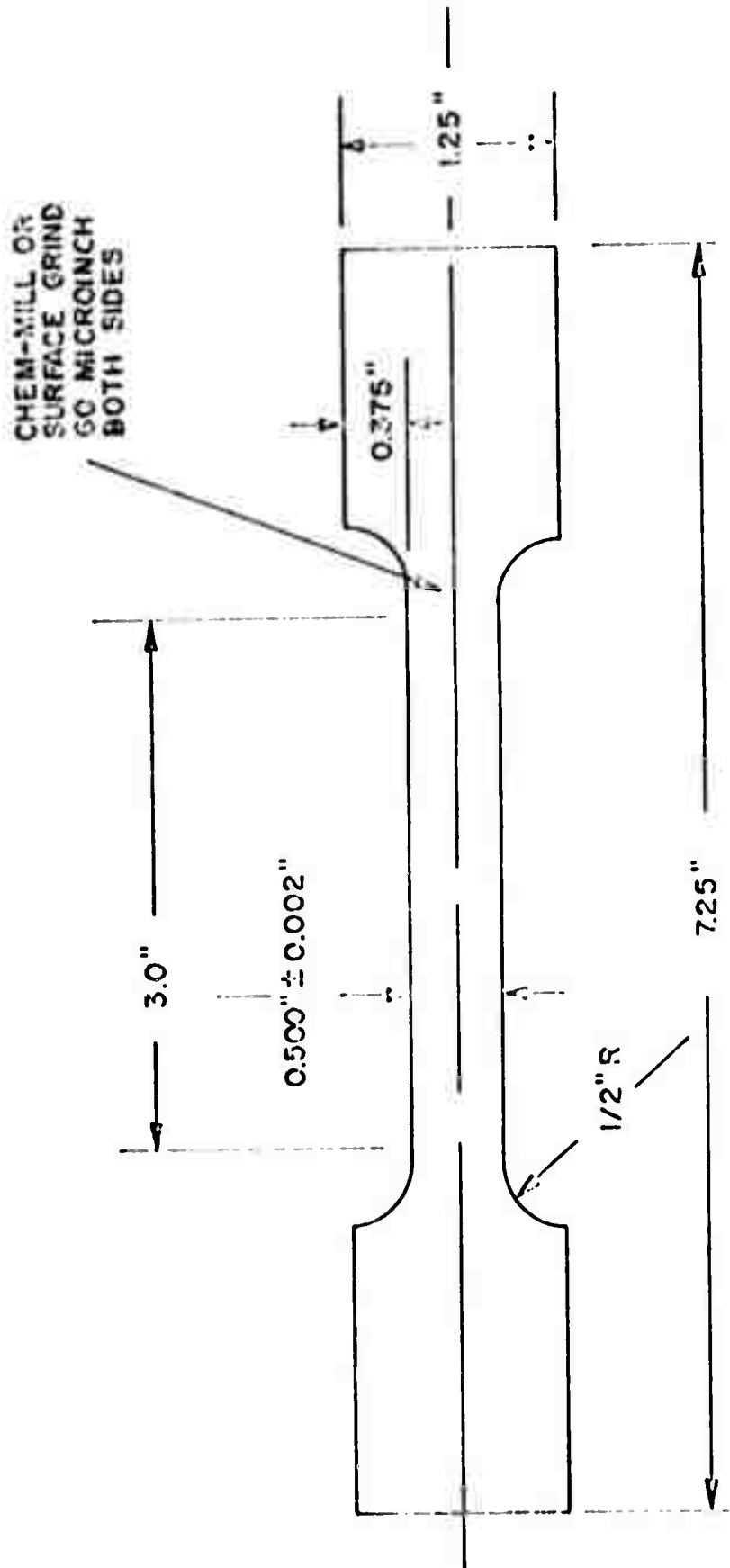

Figure 10. Exo-electron Fatigue Test Specimen.

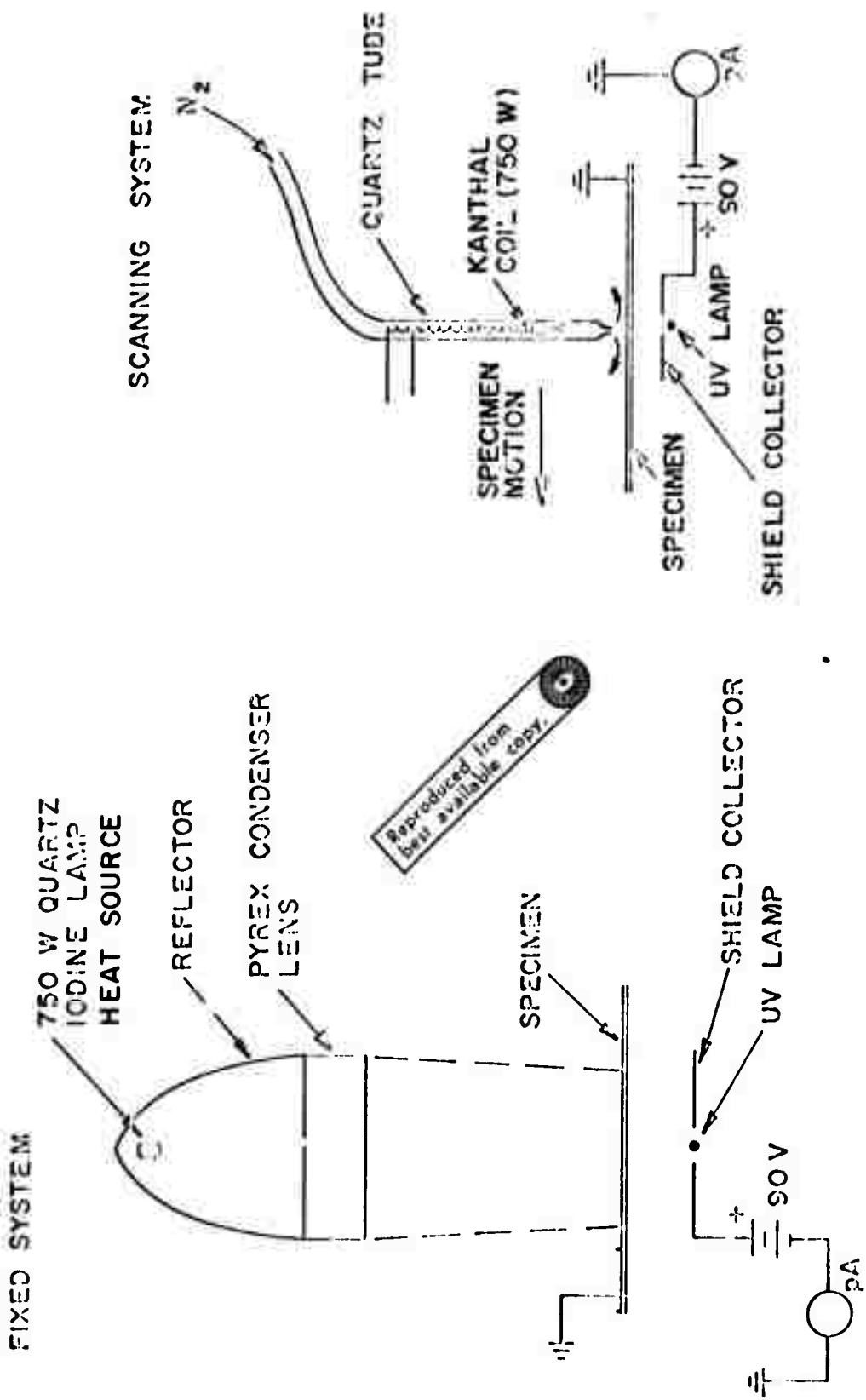

Figure 11. Exo-electron Heating and Electrical Systems.

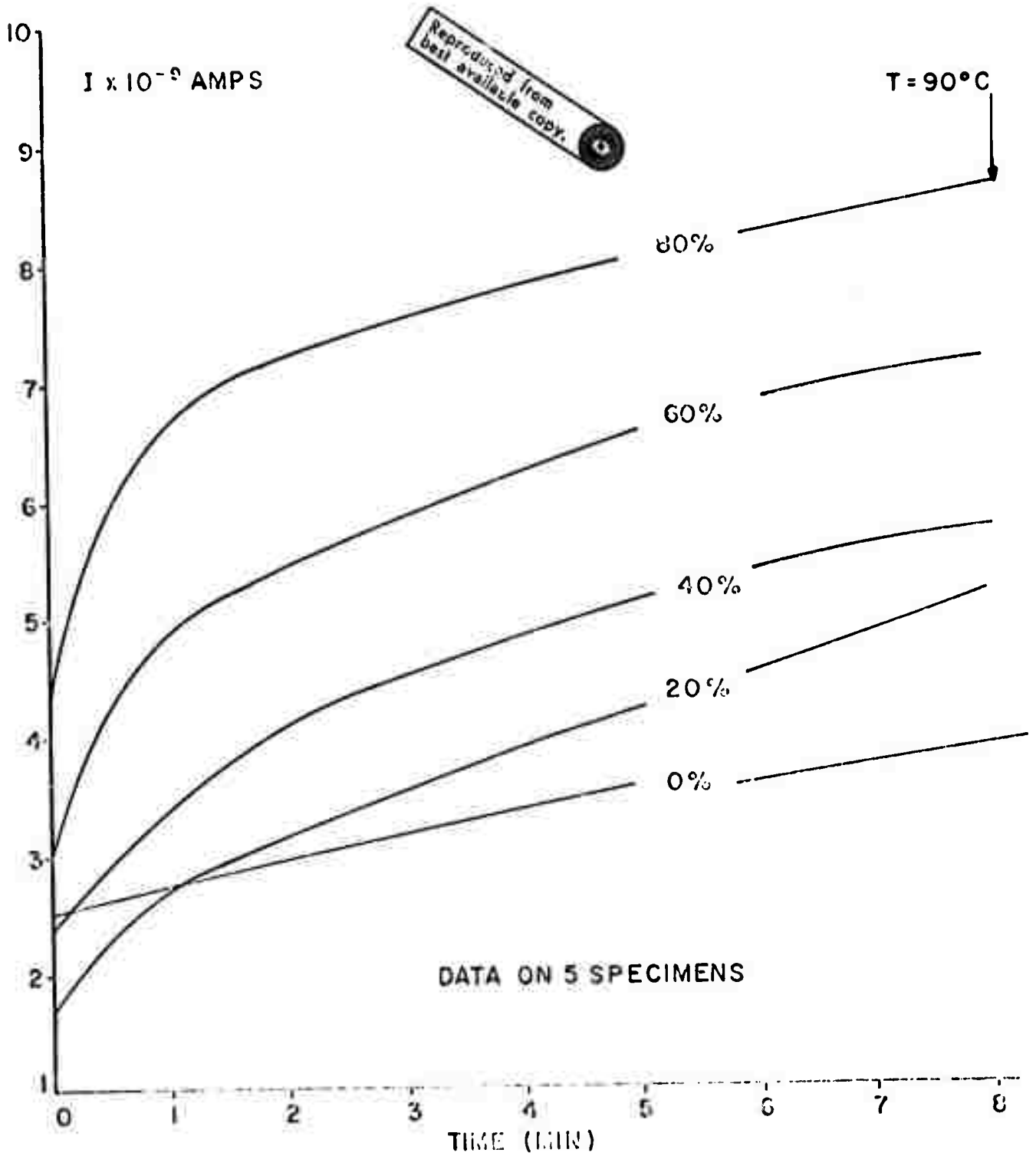

Figure 12. Exo-electron Current vs. Time and Fatigue Level (1100-0 aluminum).

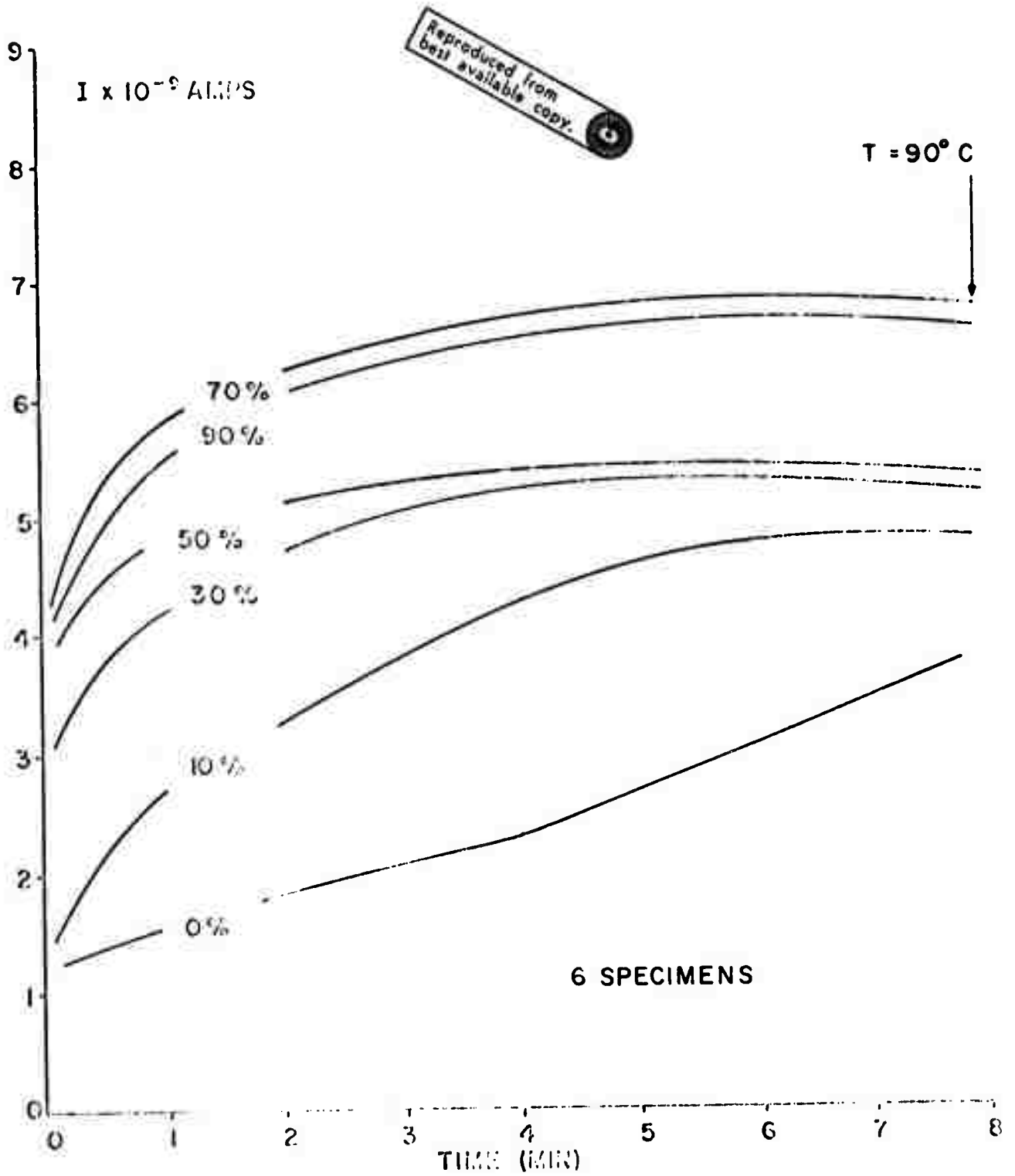

Figure 13. Exo-electron Current vs. Time and Fatigue Level (1100-0 aluminum).

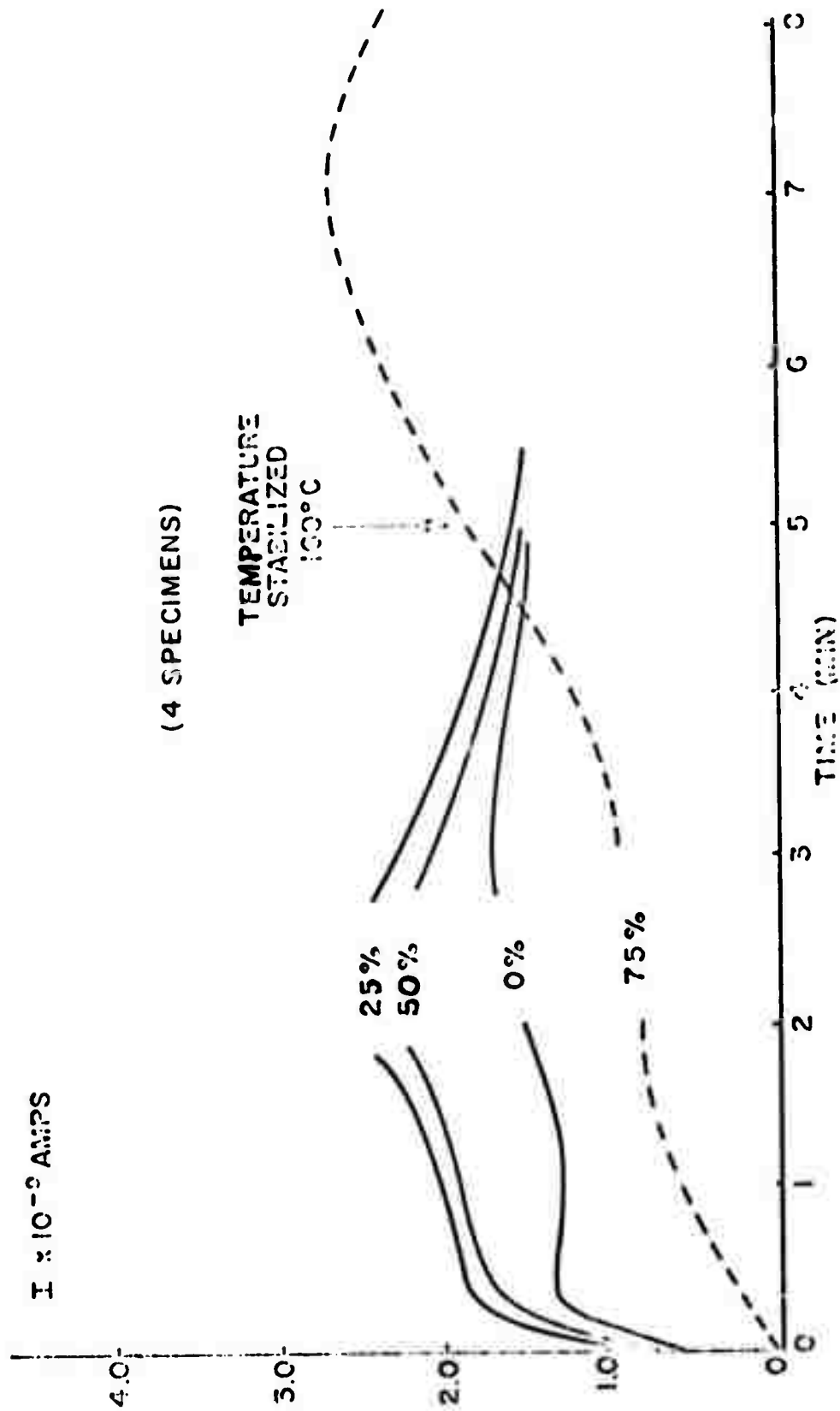

Figure 14. Exo-electron Current vs. Time and Fatigue Level (7075-T6 aluminum).

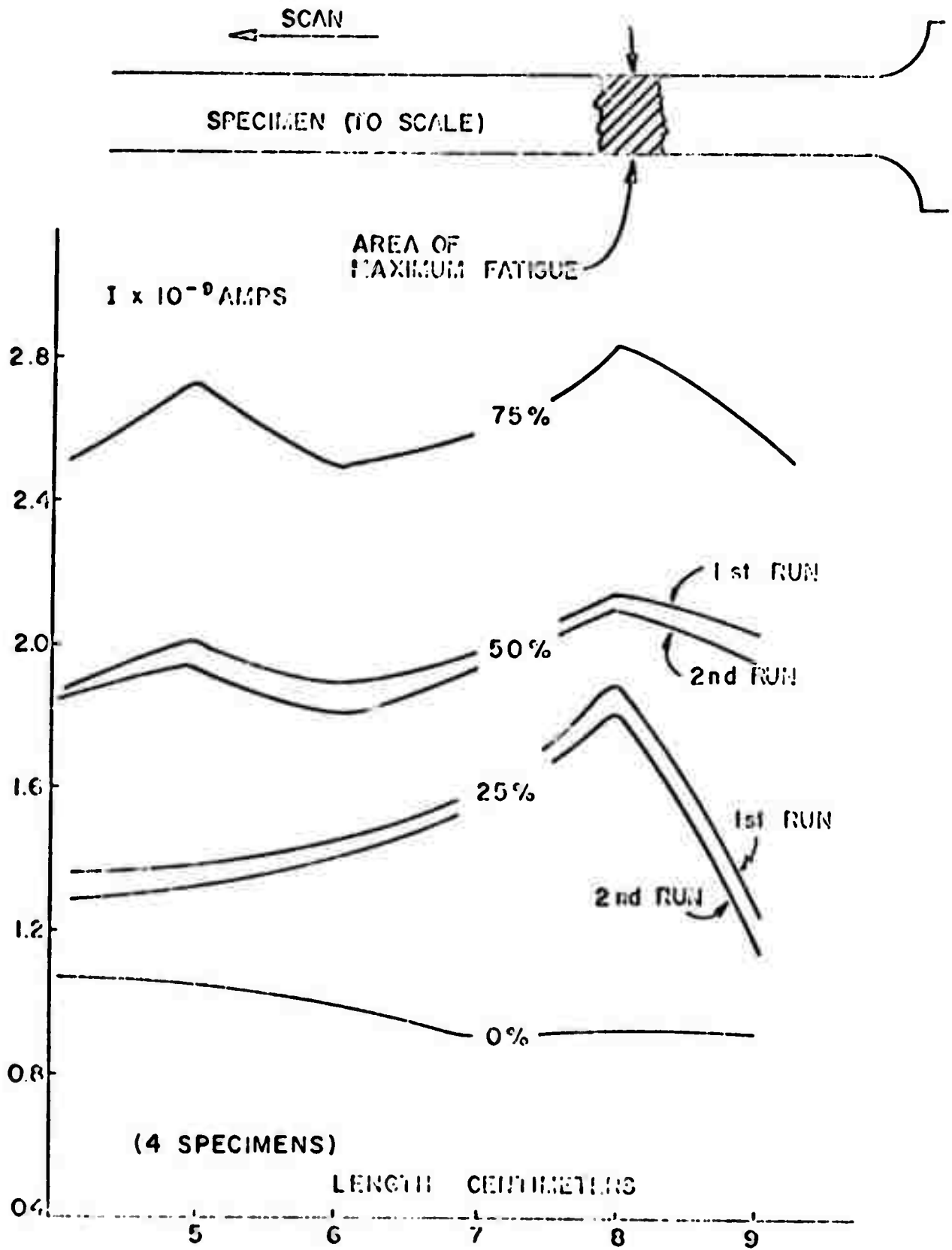

Figure 15. Exo-electron Current vs. Length and Fatigue Level (7075-T6 aluminum).

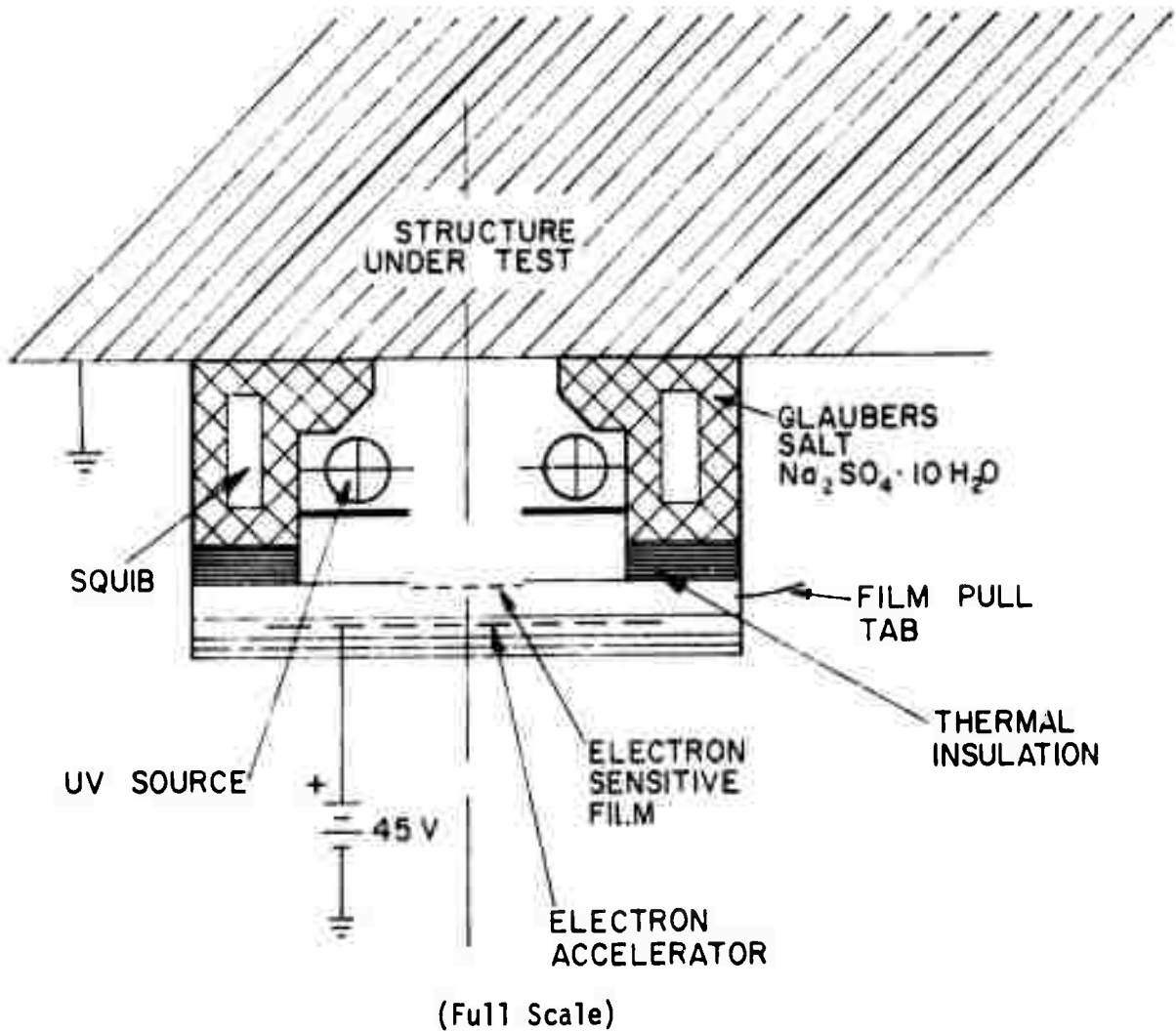

Figure 16. Placket Detector.

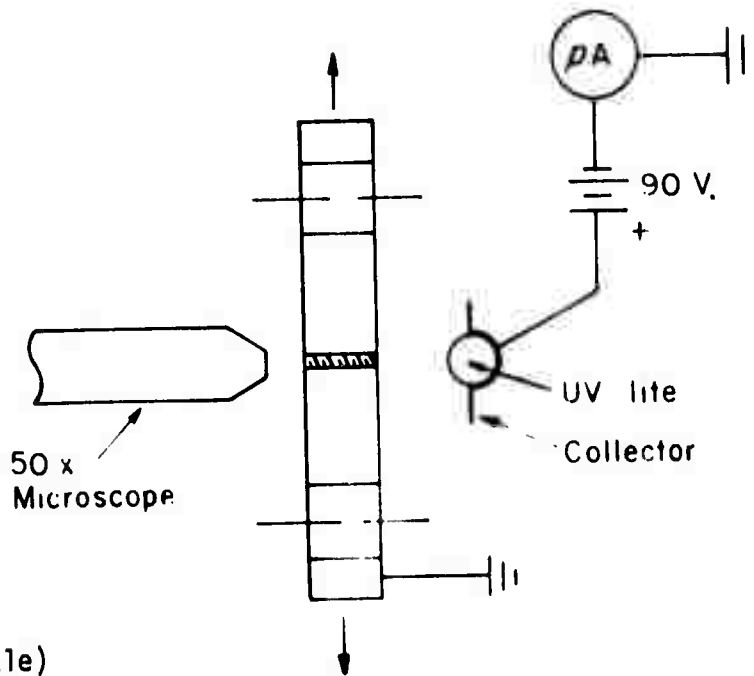
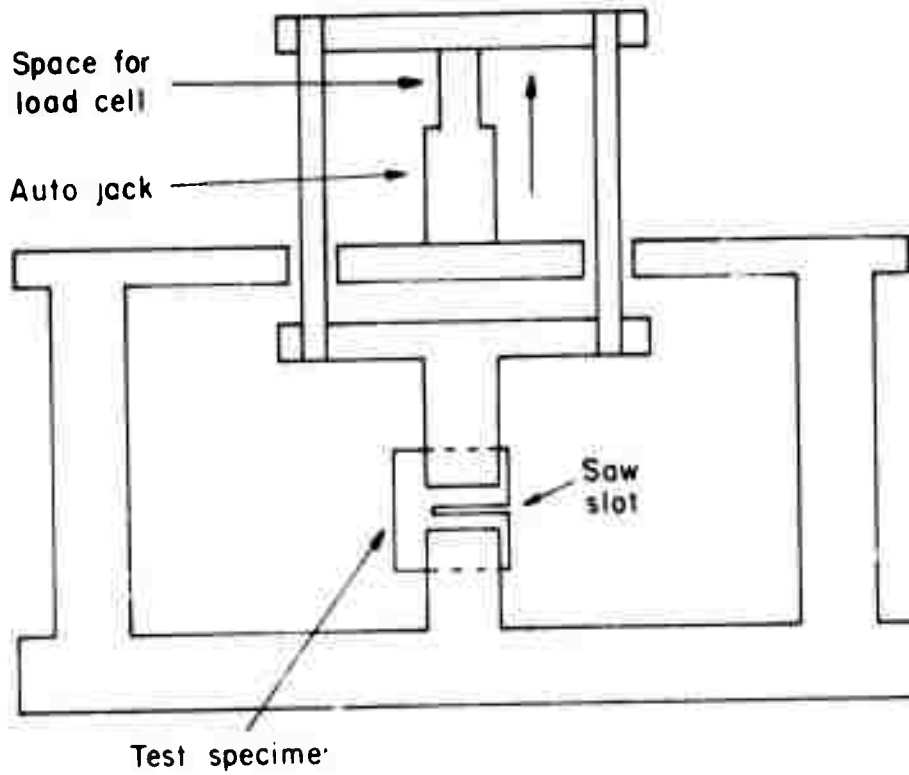

Figure 17. Test Fixture and Specimen.

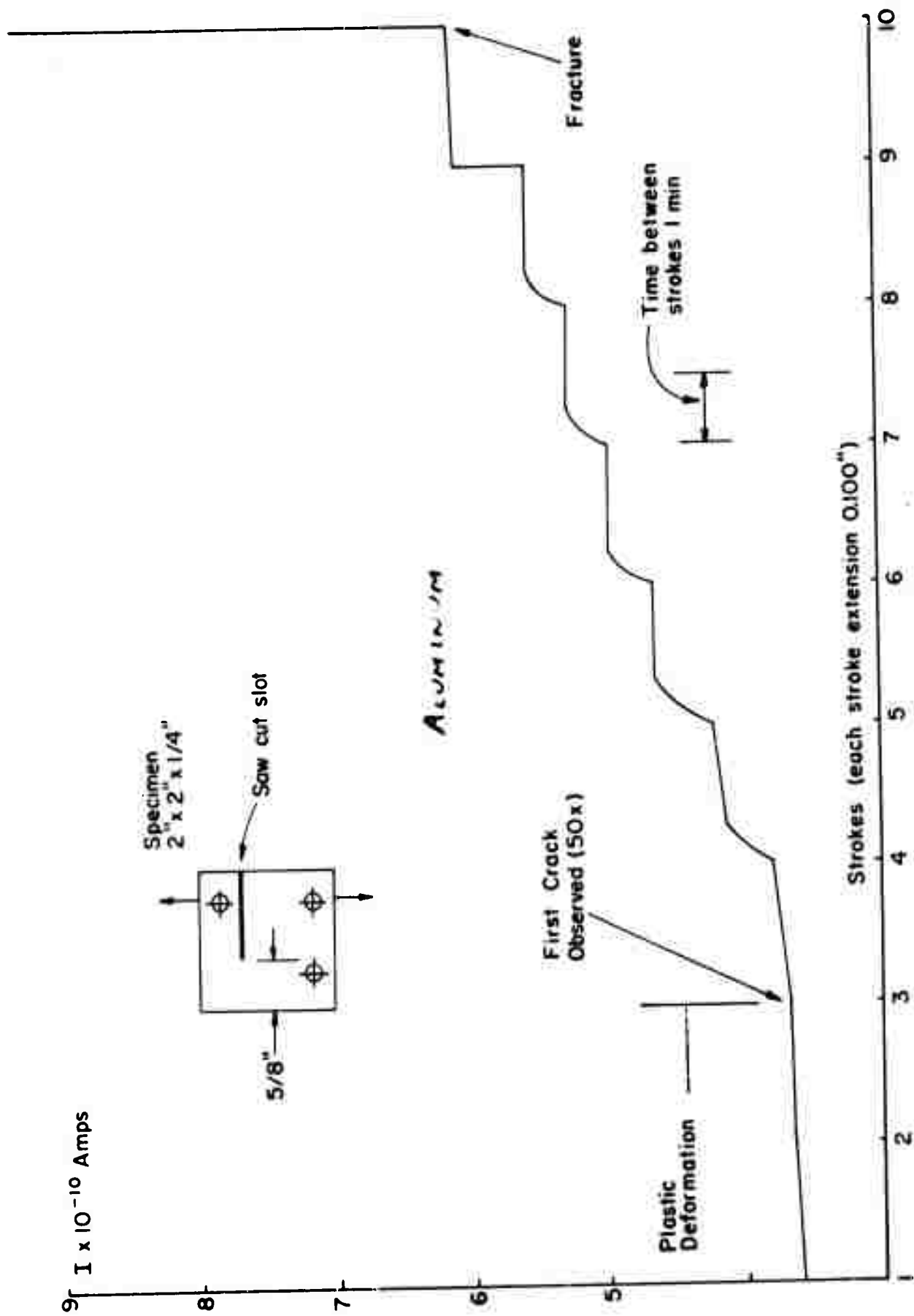

Figure 18. Exo-electron Current vs. Crack Growth (aluminum).

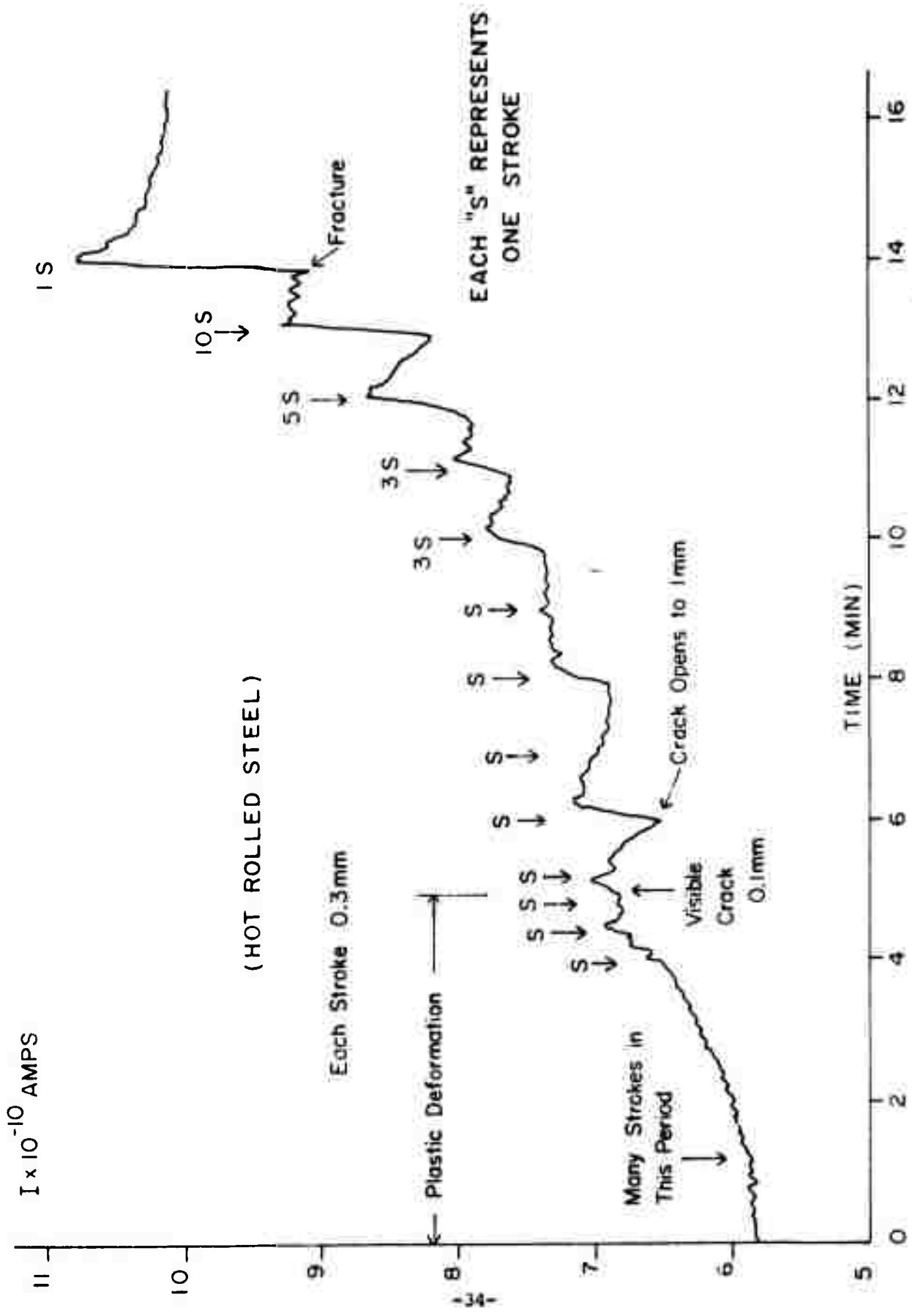

Figure 19. Exo-electron Current vs. Crack Growth (hot rolled steel).

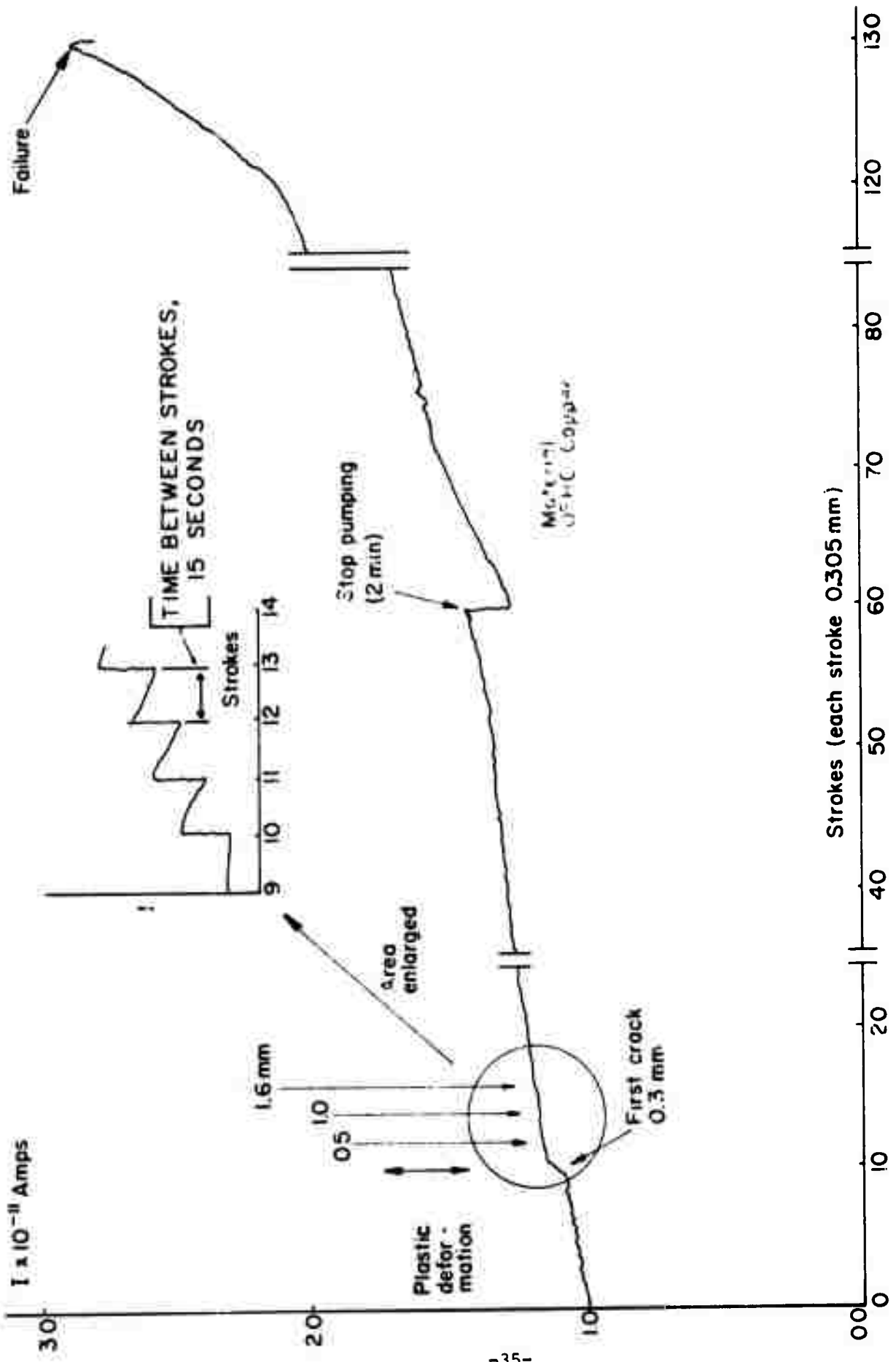

Figure 20. Exo-electron Current vs. Crack Growth (OFHC copper).