

AD-751 536

UNDERWATER SOUND TRANSDUCER CALIBRATION  
SYSTEM FOR THE 0.3- TO 2000-Hz FREQUENCY  
RANGE AT HYDROSTATIC PRESSURE TO 6.89 MPa

Harris J. Hebert, et al

Naval Research Laboratory  
Orlando, Florida

20 October 1972

DISTRIBUTED BY:

**NTIS**

National Technical Information Service  
U. S. DEPARTMENT OF COMMERCE  
5285 Port Royal Road, Springfield Va. 22151

NRL Report 7502

AD 751 536

**Underwater Sound Transducer Calibration System  
for the 0.3- to 2000-Hz Frequency Range  
at Hydrostatic Pressure to 6.89 MPa**

HARRIS J. HEBERT

*Measurements Branch*

and

LYNN P. BROWDER

*Methods and Systems Branch  
Underwater Sound Reference Division*



20 October 1972



Reproduced by  
NATIONAL TECHNICAL  
INFORMATION SERVICE  
U S Department of Commerce  
Springfield VA 22151

**NAVAL RESEARCH LABORATORY**  
**Underwater Sound Reference Division**  
**P. O. Box 8337, Orlando, Fla. 32806**

Approved for public release: distribution unlimited.

18

## DOCUMENT CONTROL DATA - R &amp; D

(Security classification of title, body of abstract and indexing annotation must be entered when the overall report is classified)

1. ORIGINATING ACTIVITY (Corporate author) Naval Research Laboratory Underwater Sound Reference Division P. O. Box 8337, Orlando, Fla. 32806		2a. REPORT SECURITY CLASSIFICATION Unclassified	
		2b. GROUP	
3. REPORT TITLE UNDERWATER SOUND TRANSDUCER CALIBRATION SYSTEM FOR THE 0.3- TO 2000-Hz FREQUENCY RANGE AT HYDROSTATIC PRESSURE TO 6.89 MPa			
4. DESCRIPTIVE NOTES (Type of report and inclusive dates) Interim report			
5. AUTHOR(S) (First name, middle initial, last name) Harris J. Hebert Lynn P. Browder			
6. REPORT DATE 20 October 1972		7a. TOTAL NO. OF PAGES ii + 16	7b. NO. OF REFS 13
8a. CONTRACT OR GRANT NO. NRL Problem K03-30		9a. ORIGINATOR'S REPORT NUMBER(S) NRL Report 7502	
b. PROJECT NO. RF 05-111-401--4470		9b. OTHER REPORT NO(S) (Any other numbers that may be assigned this report)	
c.			
d.			
10. DISTRIBUTION STATEMENT Approved for public release; distribution unlimited			
11. SUPPLEMENTARY NOTES		12. SPONSORING MILITARY ACTIVITY Office of Naval Research Department of the Navy Arlington, Va. 22217	
13. ABSTRACT  A controlled-environment system has been constructed to facilitate calibration of a wide variety of underwater sound transducers in the frequency range 0.3-2000 Hz at static pressure to 6.89 MPa (1000 lb/in <sup>2</sup> ) and temperature from -2 to +40°C. This report describes electronic and mechanical features of the system, including active impedance termination, extension of frequency range upward to 2000 Hz, and automatic recording of end-of-cable sensitivity.			

ia

14. KEY WORDS	LINK A		LINK B		LINK C	
	ROLE	WT	ROLE	WT	ROLE	WT
Acoustic measurement systems Calibration systems Transducer calibration Hydrophone calibration Pressure vessels Technical facilities						
<i>ib</i>						

## Contents

<del>Abstract</del> . . . . .	<del>ii</del>
Problem Status . . . . .	ii
Problem Authorization . . . . .	ii
Introduction . . . . .	1
Calibration Methods . . . . .	1
Mechanical Details . . . . .	4
System Transducers and Hydrophones . . . . .	8
Operational Characteristics . . . . .	8
Arrangement of Electronic Equipment . . . . .	9
Transmitting Section . . . . .	9
Receiving Section . . . . .	11
Conclusion . . . . .	13
References . . . . .	13

## Illustrations

Fig. 1. Physical arrangement of sound source and transducers in the calibration chamber and block diagram of the measuring system for comparison calibrations in a standing-wave field . . . . .	2
Fig. 2. Arrangement of instrumentation in the calibration chamber and block diagram of the electronic equipment for comparison calibration in a plane-wave field . . . . .	3
Fig. 3. Arrangement of instrumentation in the calibration chamber for the Two-Projector Null calibration, and block diagram of the electronic equipment . . . . .	4
Fig. 4. Calibration chamber, piping, and suspension system . . . . .	5
Fig. 5. Diagram of the external piping system . . . . .	6
Fig. 6. Control console . . . . .	6
Fig. 7. Top cover and packing gland . . . . .	7
Fig. 8. Multiconductor plug . . . . .	7
Fig. 9. Equivalent noise pressure level in water-filled System K . . . . .	8
Fig. 10. Sound speed as a function of pressure and temperature in 33% ethylene glycol solution in System K . . . . .	9
Fig. 11. Transmitting section . . . . .	10
Fig. 12. High-voltage drive schematic . . . . .	10
Fig. 13. Receiving section . . . . .	11
Fig. 14. Delay line instrumentation . . . . .	12

# UNDERWATER SOUND TRANSDUCER CALIBRATION SYSTEM FOR THE 0.3- TO 2000-Hz FREQUENCY RANGE AT HYDROSTATIC PRESSURE TO 6.89 MPa

## Introduction

The two low-frequency calibration systems at the Underwater Sound Reference Division (USRD) derive from a system designed and constructed by the Bell Telephone Laboratories and the Western Electric Company in the early 1940's for calibrating small hydrophones in the frequency range 0.5 to 100 Hz at room ambient temperature and at hydrostatic pressures to 689 kPa (100 lb/in<sup>2</sup> gage) [1,2]. These systems now constitute the Navy's principal laboratory facility for low-frequency hydrophone calibration.

This report describes the present USRD System K, which evolved from the original BTL design through a succession of modifications made during the period from the early 1950's to 1969 [3]. Temperature control was added, the small brass calibration chamber was replaced by a larger steel vessel that increased the hydrostatic pressure limit tenfold to 6.89 MPa (1000 lb/in<sup>2</sup>), and finally a completely new facility was constructed. The new facility incorporates solid-state integrated-circuit components, a new stainless steel pressure vessel, and new temperature and pressure controls. It features active impedance termination, frequency range from 0.3 to 2000 Hz, automatic recording of the end-of-cable sensitivity of a transducer in the frequency range 0.5 to 1000 Hz, and possibly the lowest ambient noise level of any existing calibration system.

A 33% solution of ethylene glycol in water is used in the system so that a more rapid rate of cooling is possible, reducing the time required to reach the nominal 4°C low-temperature limit. In addition, hydrophones to be used in Arctic waters can be calibrated in the system at the freezing point of seawater (-2°C).

The companion USRD System J [4,5,6] operates in the frequency range 10 to 4000 Hz and at hydrostatic pressures to 68.9 MPa.

## Calibration Methods

The calibration procedure most often used in this system is a comparison or secondary method, in which the unknown and the standard transducers are suspended in the calibration chamber at the same time with their acoustic centers in the same horizontal plane near the bottom.

Because the rigid chamber bottom is a point of maximum pressure, the two transducers are subjected to the same sound pressure within a limited frequency range. By comparing the output voltage of the unknown transducer with that of the standard of known sensitivity, the receiving sensitivity of the unknown and the relative phase between the outputs can be determined. This method can be used for small, pressure-sensitive, non-resonant transducers whose active element is much less than a quarter wavelength at the highest frequency of the calibration. For most transducers, this quarter-wavelength restriction places the upper frequency limit at 1 kHz or lower. The low-frequency limit is determined by the lowest frequency at which a usable sound pressure can be established in the chamber and by the capabilities of the measuring system. For this system, the lower frequency limit is 0.3 Hz.

Figure 1 shows the physical arrangement of the sound source and transducers in the chamber with the block diagram of the measuring system used in making comparison calibration measurements in a standing wave. The data from this system can be recorded either point by point or automatically by an X-Y recorder.

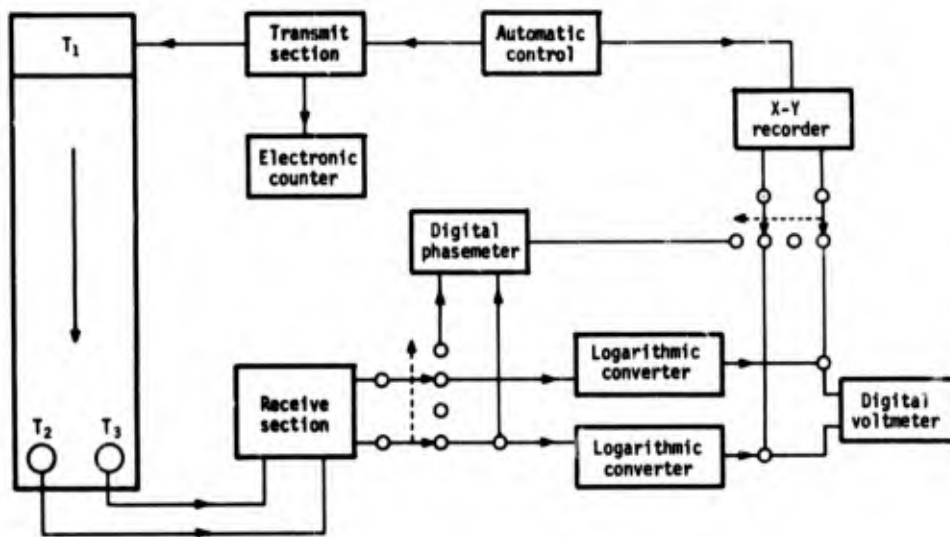

Fig. 1. Physical arrangement of sound source and transducers in the calibration chamber and block diagram of the measuring system for comparison calibrations in a standing-wave field.  $T_1$  is the source,  $T_2$  is the standard hydrophone, and  $T_3$  is the unknown.

Measurements for a comparison calibration in a plane-progressive sound wave are performed as described above except for different placement of the unknown transducer and elimination of the standing waves in the sound field. The physical arrangement of chamber instrumentation and a block diagram of the electronic equipment for calibration in a plane progressive wave are shown in Fig. 2. Standing waves are eliminated by

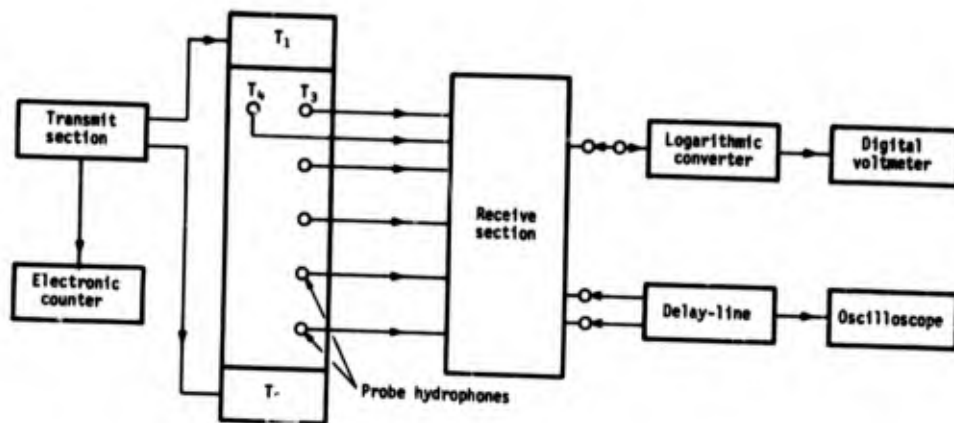

Fig. 2. Arrangement of instrumentation in the calibration chamber and block diagram of the electronic equipment for comparison calibration in a plane-wave field.  $T_1$  is the active impedance transducer,  $T_2$  is the source,  $T_3$  is the standard hydrophone, and  $T_4$  is the unknown.

driving two sound sources, one located at each end of the chamber, from a common oscillator and varying phase and amplitude of one source until the output monitors for the four probes in the sound field show equal amplitudes. Details of the active impedance termination have been described in the literature [7,8,9]. This technique not only extends the measurement capability to an upper frequency limit of 2 kHz, but also allows calibration of some types of transducers that cannot be calibrated in a standing wave. For instance, some pressure-gradient transducers for which orientation is not critical and some resonant transducers with a low  $Q$  can be calibrated.

Figure 3 shows the chamber instrumentation and a block diagram of the electronic equipment used in the Two-Projector Null (TPN) method [9,10] for primary calibration of transducers in the frequency range 0.3 to 500 Hz. This procedure requires a specially designed electrodynamic projector in which a detector is incorporated to sense motion of the diaphragm. The projector must be statically calibrated before installation to determine the quotient of its magnetic force factor to diaphragm area. The transducer to be calibrated and the null projector are placed at one end of the chamber and a sound source is placed at the other. The sound source and the null projector are driven by a common two-channel oscillator. The current driving the source and its phase relative to that driving the null projector can be adjusted manually until the motion-sensing detector indicates no motion of the null projector diaphragm. The sensitivity of the unknown transducer then is computed from the predetermined static constant, the output voltage of the transducer, and the current driving the null projector.

The standard transducer is calibrated in the frequency range 500 to 2000 Hz by the coupler reciprocity technique [9,11] independently of System K. The coupler is a small, oil-filled chamber containing a

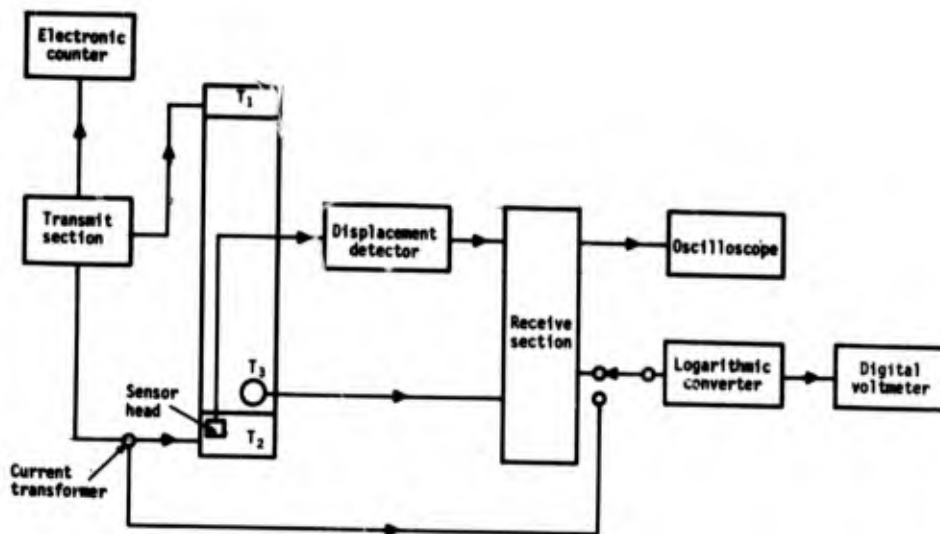

Fig. 3. Arrangement of instrumentation in the calibration chamber for the Two-Projector Null calibration, and block diagram of the electronic equipment.  $T_1$  is the source,  $T_2$  is the null projector, and  $T_3$  is the hydrophone being calibrated.

transducer used only as a sound source, a transducer used reciprocally as a source and a receiver, and a transducer used only as a receiver. The receiving transducer may be the standard hydrophone to be calibrated. The coupler operates at any hydrostatic pressure, thereby providing information on the stability of the reference hydrophone with pressure. The accuracy of this method is  $\pm 0.2$  dB.

### Mechanical Details

System components including the tube in its suspension system are shown in Fig. 4. The tube is 183 cm long with inside diameter 28 cm and wall thickness 2.5 cm. To minimize corrosion, it is constructed of stainless steel and the piping is of stainless steel, copper, or plastic. The tube is supported by four feet welded to the wall and resting on air springs attached to the metal support frame. The air springs provide mechanical isolation from the building and electrical isolation from common grounds, resulting in the low ambient noise level necessary for calibrating transducers that have high-gain amplifiers. Rubber and plastic tubing used for air and water lines further isolate the chamber.

Top and bottom fittings connect the calibration chamber into a closed system that allows water circulation through the chamber under vacuum. This arrangement prevents entrapment of air in the rigging frame and around the transducers. Nitrogen gas is used to pressurize the chamber through an accumulator consisting of a neoprene bag inside a steel shell. The neoprene bag, connected to the calibration chamber as shown in Fig. 5

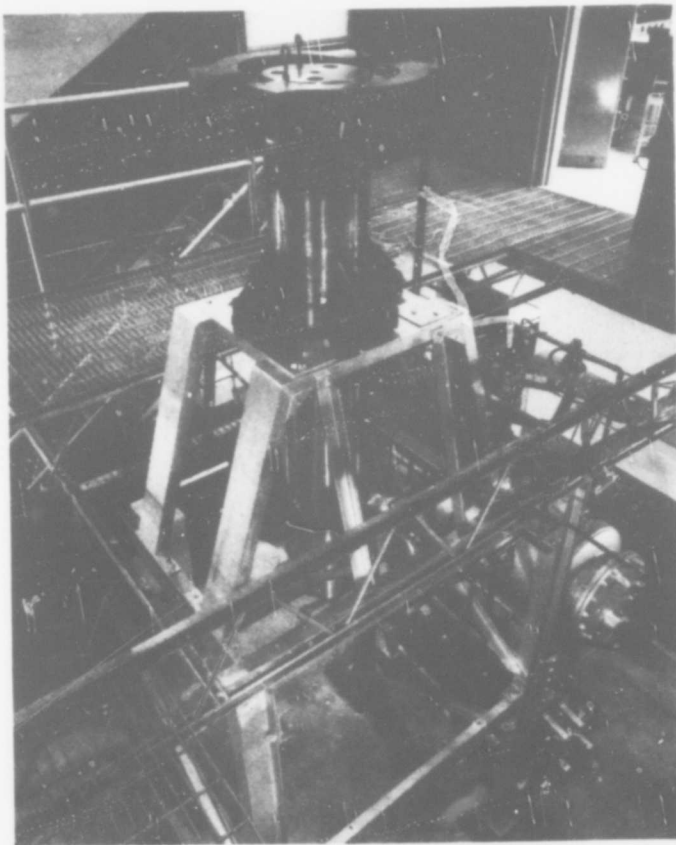

Fig. 4. Calibration chamber, piping, and suspension system.

and filled with water, is compressed by nitrogen applied inside the steel shell; it thus transmits pressure to the interior of the tube. This method of pressurization is used exclusively. Furthermore, it is necessary when an electrodynamic projector like that used in the TPN method is part of the system. Nitrogen pressurization applied to the accumulator is transmitted also to the back of the TPN projector diaphragm to keep it balanced and to allow the projector to function with its coil positioned in the magnetic gap as it was when calibrated statically.

Normal mechanical functions of this system are controlled from a console (Fig. 6) containing air operators for system valves. This console is designed so that each control represents the corresponding valve in a simplified piping diagram drawn on the panel. The temperature controller and readouts for pressure, vacuum, and temperature are mounted in the upper vertical face of the console.

Openings in the top cover and bottom plug of the tube provide entry for cables from sound sources and transducers being calibrated. The top cover contains three openings 3.8 cm in diameter that are used for cable packing glands, and one water outlet opening 2.54 cm in diameter. The bottom plug contains two openings 2.54 cm in diameter, one for a water inlet and the other for a packing gland. The packing gland most frequently used to bring out cables on transducers being calibrated is of

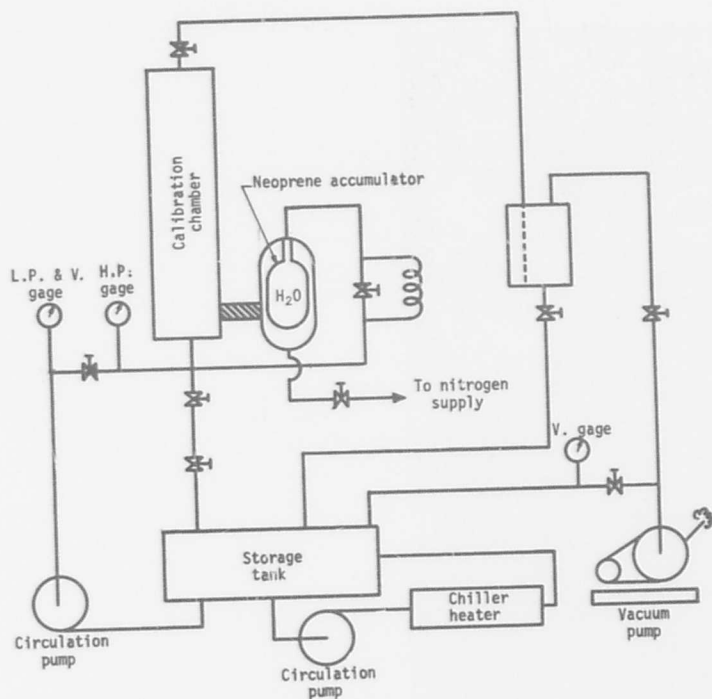

Fig. 5. Diagram of the external piping system.

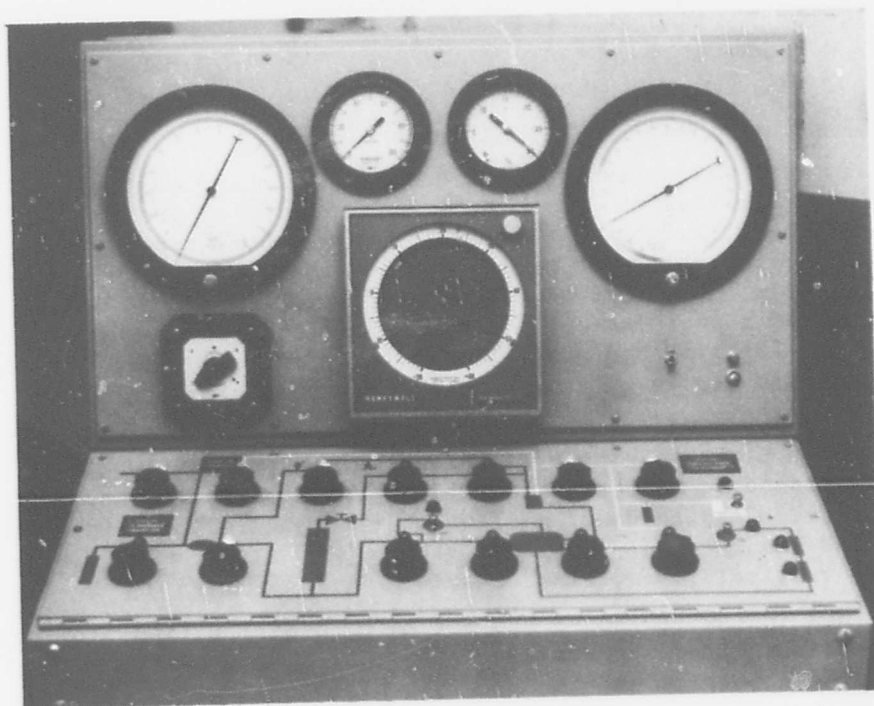

Fig. 6. Control console.

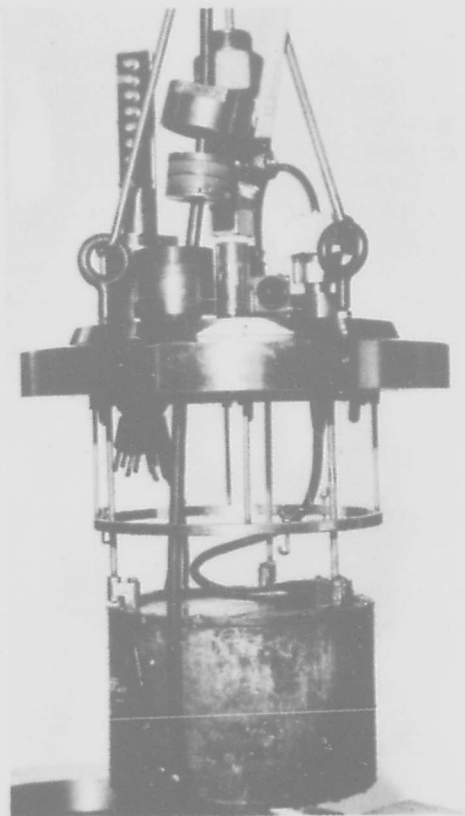

Fig. 7. Top cover and packing gland.

the compression type with the packing material split, eliminating the need for removing most plugs from cables. The top cover and the packing gland with the split packing are shown in Fig. 7. A special multi-conductor plug that can handle up to 16 conductors is used for transducers fitted with suitable connectors. This is accomplished by using a pair of four-pin Electro Oceanic connectors (Fig. 8).

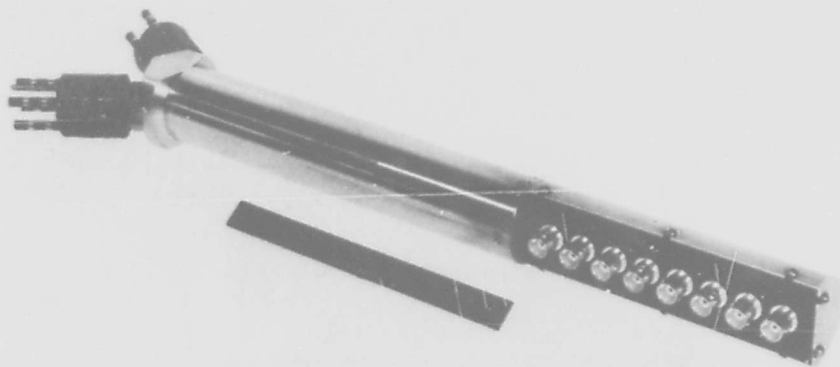

Fig. 8. Multiconductor plug.

## System Transducers and Hydrophones

Instrumentation used in this system is similar to that used in other systems at the USRD [5,6]. The G23K projector (sound source) and the type A40 hydrophones are the same as those reported for System J [6]. The standard hydrophone type H48 [12] that is used as the reference hydrophone for comparison calibrations was designed especially for low frequencies and for calibration by reciprocity in the USRD high-pressure chamber [11].

## Operational Characteristics

A typical sound pressure level in this chamber is 155 dB re 1  $\mu$ Pa for the frequency range 0.3 to 10 Hz. From 10 to 1000 Hz, the level increases to 170 dB. Careful consideration has been given to isolating the chamber from ambient acoustic noise. As a result, the noise level is lower than that in other USRD chambers. The equivalent noise pressure in the chamber under optimum conditions is shown in Fig. 9.

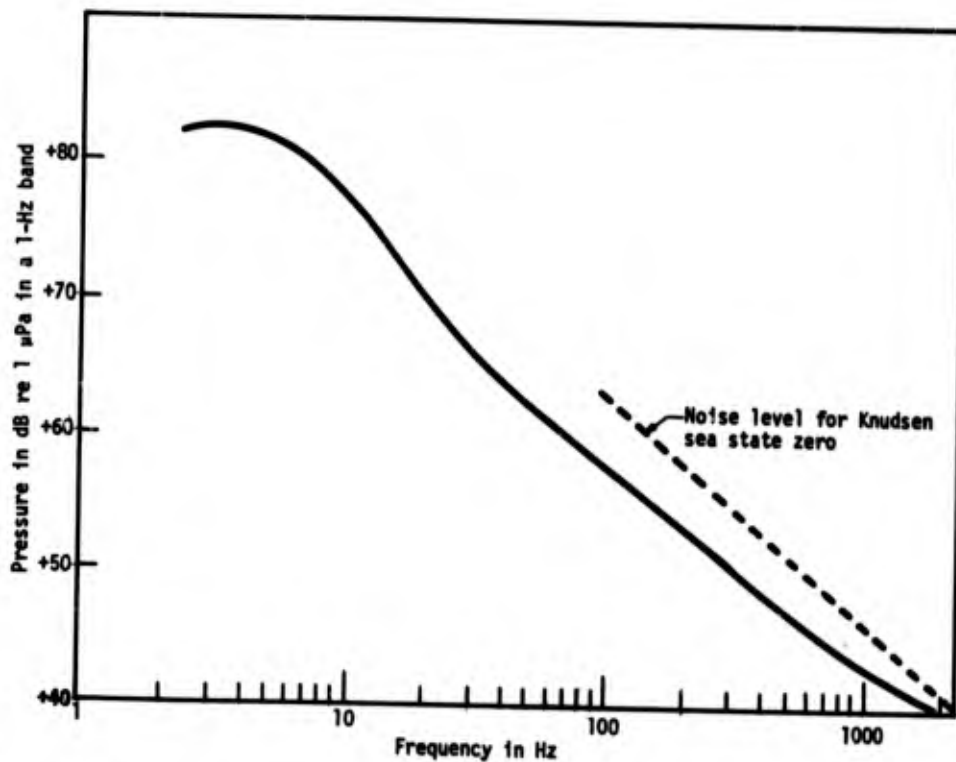

Fig. 9. Equivalent noise pressure level in water-filled System K.

A velocimeter was used to measure the speed of sound as a function of temperature and pressure in the medium used in this system. Because the medium is a solution of deionized water and ethylene glycol, the sound speed in it is higher than in pure water. Figure 10 shows sound speed as

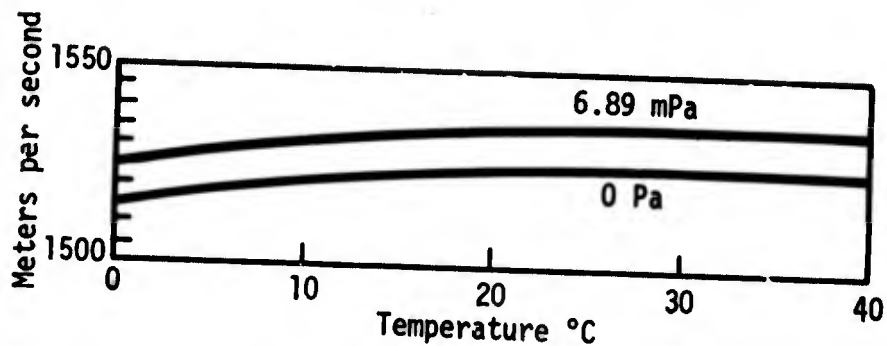

Fig. 10. Sound speed as a function of pressure and temperature in 33% ethylene glycol solution in System K.

a function of pressure and temperature, corrected for the effect of the tube as calculated from an equation given by Kuhl [13].

### Arrangement of the Electronics Equipment

The electronics equipment, located in four racks about ten feet from the calibration chamber, is interconnected through jack panels for maximum versatility. For convenience, the racks are arranged in a semicircle. A-c power is supplied through a 5-kW isolation transformer. Although all of the equipment racks and the calibration chamber are tied together by a copper bus bar connected to a special grounding rod, they are otherwise electrically isolated from the building and power ground circuits to minimize ground loops.

### Transmitting Section

A block diagram of this section is shown in Fig. 11. The function generator has two highly stable, low-distortion, sinusoidal outputs. One is a reference signal; the phase of the other is variable through  $360^\circ$ . The short-term frequency variation of this unit is less than 0.01%. Distortion and hum are less than 0.06% at full output. Phase-dial accuracy is  $\pm 5^\circ$ , which is adequate for adjusting phase. The amplitudes of the two output signals can be adjusted independently by attenuators. A square-wave output from the function generator produces synchronizing signals for the oscilloscope and the electronic counter.

Two types of power amplifier in the system can be interconnected to serve a variety of applications. Two 50-W amplifiers are used primarily to drive the system transducers. Each amplifier can supply 180 V maximum across a capacitive load in the frequency range 0 to 2500 Hz. Each can be used individually or both can be connected for balanced drive at 360 V. Two 10-W operational d-c amplifiers drive low-impedance transducers when they are used, as in the TPN method, and also drive the low-impedance calibrating circuits. The gain of each of these amplifiers is 20 dB; output hum and noise are less than 200  $\mu$ V. Sometimes the output voltage

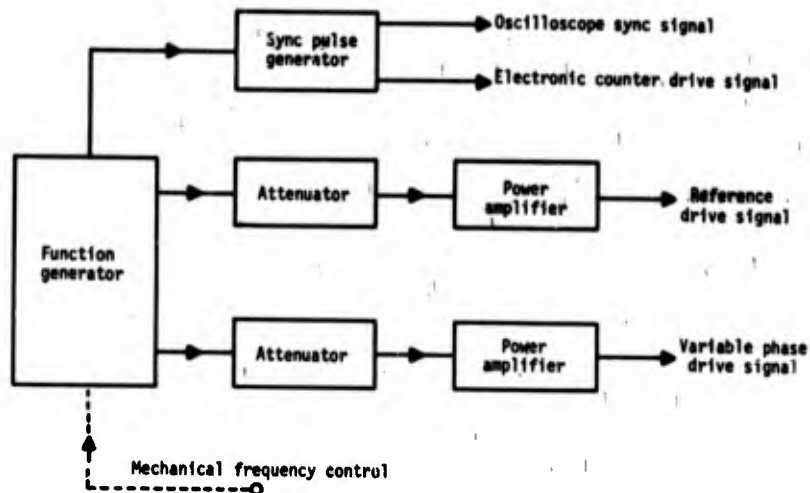

Fig. 11. Transmitting section.

of the function generator is boosted by one of these amplifiers to provide maximum drive for the 50-W amplifiers.

Two operational power supplies (Kepco Model OPS-2000) are interconnected to drive a system transducer at 1400 V (rms) in the frequency range 0.3 to 5 Hz. One of the 10-W amplifiers is used to shift the phase of the input signal by  $180^\circ$  so that the output voltages of the power supplies will be out of phase when they are connected as operational amplifiers for balanced drive. Figure 12 shows the diagram for the high-voltage drive configuration.

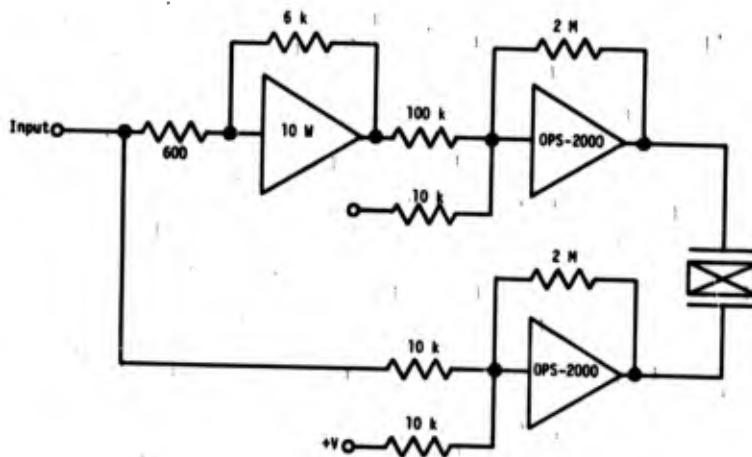

Fig. 12. High-voltage drive schematic.

The acoustic pressure level in the chamber can be controlled automatically by the General Radio Model 1569 automatic level regulator. This device adjusts the input signal to the power amplifier to maintain

the electronic driving level to the source transducer at the value that will keep the voltage output of the standard hydrophone constant. If the electronic driving level of the source transducer is not controlled, the sound level in the chamber will vary over a wide dynamic range as the frequency is changed. Automatic level control assures that the unknown hydrophone will be calibrated under virtually constant sound pressure.

### Receiving Section

A block diagram of this section is shown in Fig. 13. The "auxiliary" and the "standard" channels alone are used for all types of calibration except comparison calibration in a plane progressive wave. The auxiliary channel is available for use with the unknown hydrophone. A signal to measure the hydrophone voltage coupling gain or loss can be applied to the input of either channel through 10- $\Omega$  precision resistors.

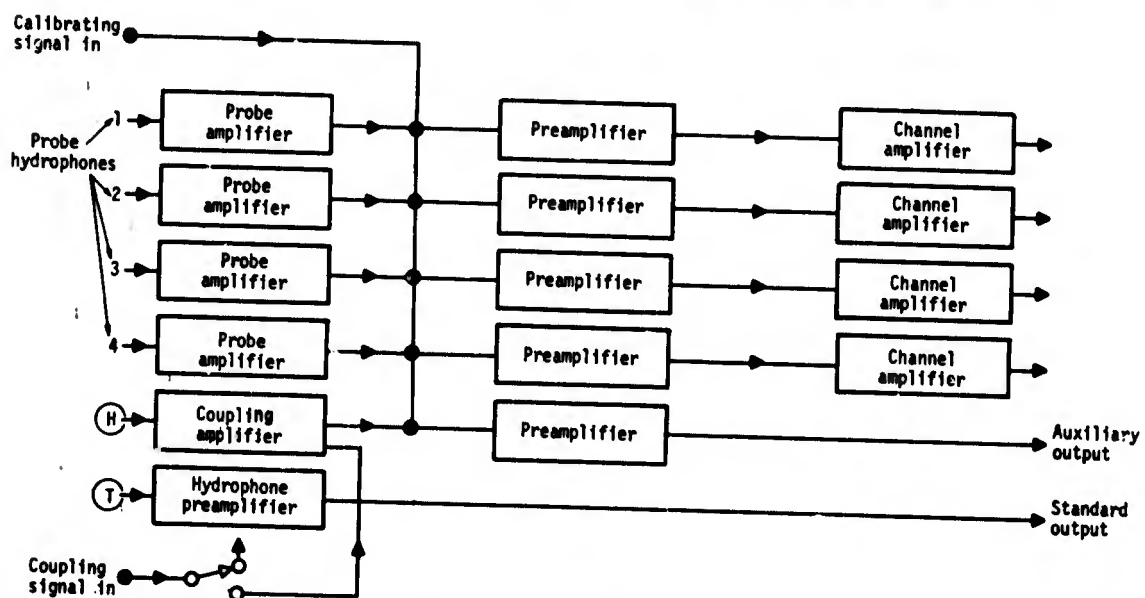

Fig. 13. Receiving section: H is the hydrophone being calibrated and T is the standard hydrophone.

To record automatically the sensitivity of the unknown hydrophone relative to that of the standard hydrophone, the frequency dial of the function generator is advanced incrementally by a stepper motor and mechanical gear linkage. A linear potentiometer driven by the same linkage provides analog frequency data to the X-Y recorder. Each time the frequency is changed, a "dwell time" is inserted to enable transient conditions in the system to stabilize before the next "record" signal is sent to the pen of the recorder. The size of the incremental frequency step and the length of dwell time can be varied independently. This process can be controlled manually when measurements are to be made at selected frequencies.

A calibrating signal is applied simultaneously to all of the probe hydrophone preamplifiers through a specially designed transformer having multiple secondaries that are identical. Thus, equal signals can be applied to the receiving channels to calibrate the four channel amplifiers.

To establish a plane progressive wave in the tube by adjusting the active-impedance termination is a tedious procedure. The use of instrumentation consisting of a delay line, an attenuation compensator, a differential amplifier, and a variable filter simplifies adjustment. A block diagram of the equipment is shown in Fig. 14.

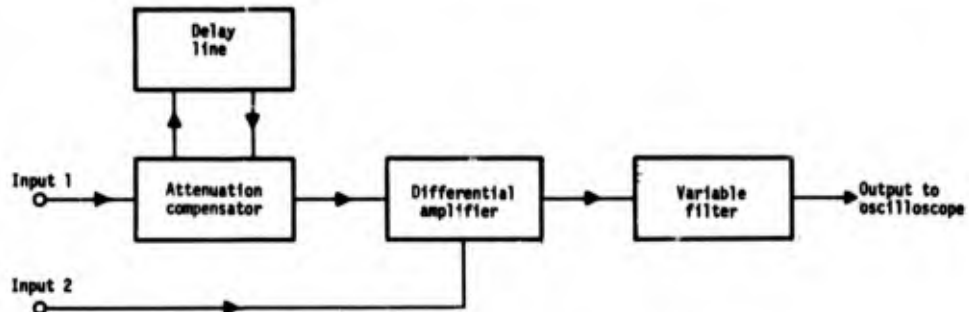

Fig. 14. Delay line instrumentation.

The signal from one of two appropriately spaced probe hydrophones is delayed by an amount equal to the calculated delay of the acoustic signal in the water path between the two hydrophones. Two signals, one delayed and one direct, are compared by the differential amplifier; when the amplitudes and the phases of the signals are equal, the output of the differential amplifier is a minimum. This output is filtered and displayed on an oscilloscope. Amplitude and phase of the signal driving the active-impedance transducer are adjusted manually in successive approximations until a null indication is achieved. The existence of minimum standing-wave ratio is confirmed by voltage measurements on each of the four probe hydrophones.

The delay line provides a delay that is variable from 0 to 1111  $\mu$ sec. Accuracy is within  $\pm 1$   $\mu$ sec at all frequencies to 2000 Hz. The attenuation compensator supplies automatic dynamic correction for loss of signal level within the delay line.

Two differential amplifiers with variable filters can be used for auxiliary gain (0 to 60 dB) or for signal conditioning in the receiving section channels when the signal received from the transducers is too low or too noisy.

The null projector is equipped with a precision electromechanical distance-sensing transducer to determine when the condition of no motion of its diaphragm exists. It has a dynamic frequency response from 0 to 10 kHz and a scale factor of about 240 V per centimeter of displacement. In an actual two-projector-null calibration, the output of the displacement detector is connected to the input of the auxiliary channel to block the d-c component; only the dynamic change is observed on the oscilloscope.

A-c voltage level from any transducer is converted to a d-c voltage proportional to the logarithm of the value of the signal. A digital voltmeter is connected to indicate decibels re one milliwatt. Two logarithmic converters can be used to monitor the outputs of two transducers; the differential output of the converters represents the relative sensitivity of the transducers. This output is displayed either as a digital readout or as a deflection of the pen on the X-Y recorder. The Hewlett-Packard Model 7562A logarithmic converter has an 80-dB dynamic range (typically, 1 mV to 10 V) and is useful in the frequency range 0.5 Hz to 100 kHz. Operation as low as 0.3 Hz is acceptable with some loss of accuracy. Three analog voltmeters are available for basic measurements and for comparison at frequencies above 10 Hz.

Phase measurements can be made above 10 Hz with a digital phase meter provided. A d-c analog voltage proportional to phase is used for automatic phase recording on the X-Y recorder.

### Conclusion

A new pressure vessel and improvements in associated equipment and instrumentation have been combined to produce a low-frequency acoustic measurement system capable of calibrating a wider variety of underwater sound transducers in a greater frequency range than was possible before and in about half the time required previously. Use of stainless steel and plastic materials has reduced corrosion problems. New procedures permit the use of plane progressive waves and increase the upper frequency to 2000 Hz. An automatic recording capability is available. In addition, the low ambient noise level of the new system permits for the first time the calibration of hydrophones with high-gain preamplifiers.

### References

- [1] E. Hartmann and E. C. Gregg, Jr., "Description and Operational Procedures of the USRL Test Stations," in *Sonar Calibration Methods* (Summary Technical Report of Div. 6, NDRC, Vol. 10), pp. 115-118.
- [2] R. J. Bobber, "The Calibration of a Low-Frequency Calibrating System," Navy Underwater Sound Reference Laboratory Report 23, 20 Aug 1952.
- [3] L. G. Beatty, "A Hydrophone Calibration System for Low Frequencies and High Static Pressures," Navy Underwater Sound Reference Laboratory Report 41, 17 Dec 1958 [AD-210 265].
- [4] L. G. Beatty and J. F. Prandoni, "Underwater Sound Transducer Calibration Facility for the 10- to 4000-Hz Frequency Range at Hydrostatic Pressure to 10,000 psig," Naval Research Laboratory Report 6965, 15 Aug 1969 [AD-693 091].

- [5] R. E. Ford and L. P. Browder, "Electronic Instrumentation of a 10,000 psig Underwater Sound Transducer Calibration Facility for the 10- to 4000-Hz Frequency Range," Naval Research Laboratory Report 6966, 15 Aug 1969 [AD-693 096].
- [6] I. D. Groves, Jr., and T. A. Henriquez, "Electroacoustic Transducers for a 10,000-psig Underwater Sound Transducer Calibration Facility for the Frequency Range 10 to 4000 Hz," Naval Research Laboratory Report 6967, 15 Aug 1969 [AD-693 051].
- [7] L. G. Beatty, "Acoustic Impedance in a Rigid-Walled Cylindrical Sound Channel Terminated at Both Ends with Active Transducers," J. Acoust. Soc. Amer. 36, 1081-1089 (1964).
- [8] L. G. Beatty, R. J. Bobber, and D. L. Phillips, "Sonar Transducer Calibration in a High-Pressure Tube," J. Acoust. Soc. Amer. 39, 48-54 (1966).
- [9] R. J. Bobber, *Underwater Electroacoustic Measurements*, (U. S. Government Printing Office, Washington, D. C., 1970), Ch. II.
- [10] W. J. Trott and E. N. Lide, "Two-Projector Null Method for Calibration of Hydrophones at Low Audio and Infrasonic Frequencies," J. Acoust. Soc. Amer. 27, 951-955 (1955).
- [11] C. C. Sims and T. A. Henriquez, "Reciprocity Calibration of a Standard Hydrophone at 16,000 psi," J. Acoust. Soc. Amer. 36, 1704-1707 (1964).
- [12] L. E. Ivey, "High-Pressure Piezoelectric Ceramic Hydrophone for Infrasonic and Audio Frequencies, USRD Type H48," Naval Research Laboratory Report 7260, 15 Mar 1971 [AD-721 069].
- [13] W. Kuhl, "Die Eigenschaften wassergefüllter Rohre für Widerstands- und Schallgeschwindigkeitsmessungen," *Acustica* 3, 111-123 (1953).