

EHL  
(K)  
72-11  
c.1

LOAN COPY: RETURN TO  
WL (SUL)  
KIRKLAND AFB, N. M.

# TECHNICAL

## Report



AN INTERDISCIPLINARY STUDY  
OF THE EFFECTS OF  
ACTUAL (REAL) AND SIMULATED  
SONIC BOOMS  
ON FARM RAISED MINK (Mustella vison)

August 1972

EHL(K) 72-11

USAF ENVIRONMENTAL  
HEALTH LABORATORY  
KELLY AFB, TEXAS

20080616 063

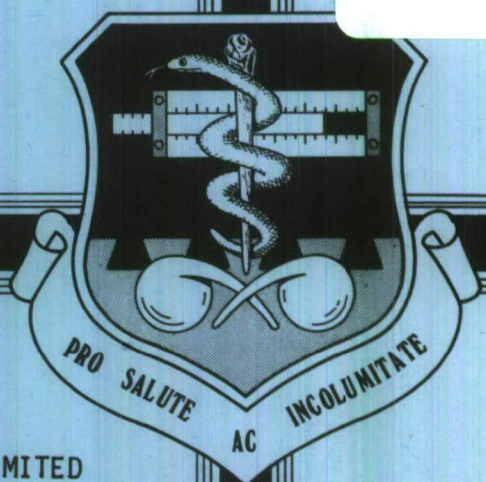

APPROVED FOR PUBLIC RELEASE; DISTRIBUTION UNLIMITED

## NOTICE

The contents of this report reflect the professional opinion of the authors who are responsible for the facts and the accuracy of the data presented herein. The contents do not necessarily reflect the official views or policies of the participating agencies. This report is not to be used for promotional or advertising purposes and does not constitute an endorsement of any product.

## PARTICIPATING AGENCIES

Department of Transportation  
Mink Farmers Research Foundation  
Mutation Mink Breeders Association  
National Academy of Sciences  
United States Air Force  
U. S. Department of Agriculture  
U. S. Department of Interior  
University of Alaska  
Washington State University

AD-751931

USAF ENVIRONMENTAL HEALTH LABORATORY (AFLC)

UNITED STATES AIR FORCE

KELLY AFB, TEXAS 78241

AN INTERDISCIPLINARY STUDY OF THE EFFECTS OF  
ACTUAL (REAL) AND SIMULATED SONIC BOOMS ON  
FARM RAISED MINK (Mustella vison)

August 1972

EHL(K) 72-11

SHORT TITLE: PROJECT "COOL MINK"

REVIEWED BY:



WALTER E. BREWER  
Lt Colonel, USAF, VC  
Air Force Consultant  
Project "Cool Mink"

APPROVED BY:

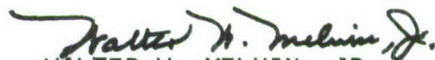

WALTER W. MELVIN, JR.  
Colonel, USAF, MC  
Commander

1. Report No. FAA EQ-72-2	2. Government Accession No.	3. Recipient's Catalog No.	
4. Title and Subtitle AN INTERDISCIPLINARY STUDY OF THE EFFECTS OF REAL AND SIMULATED SONIC BOOMS ON FARM-RAISED MINK (MUSTELA VISON)		5. Report Date August 1972	6. Performing Organization Code
7. Author(s) Hugh F. Travis, James Bond, R.L. Wilson, J. R. Leekley, J.R. Menear, C.R. Curran, F.R. Robinson, W.E. Brewer, G.A. Huttenhauer, and J.B. Henson		8. Performing Organization Report No.	
9. Performing Organization Name and Address U.S. Department of Agriculture, ARS, National Agricultural Research Center, Beltsville, Md. 20705 (James Bond, Project Leader) in cooperation with U.S. Air Force, U.S. Dept. of Transportation, Univ. of Alaska, and		10. Work Unit No.	11. Contract or Grant No. DOT FA70WAI-171
12. Sponsoring Agency Name and Address Washington State University Department of Transportation Federal Aviation Administration Office of Environmental Quality Washington, D. C. 20591		13. Type of Report and Period Covered FINAL	
15. Supplementary Notes This project was sponsored by the FAA via an interagency agreement with the Agricultural Research Service, U.S. Department of Agriculture.		14. Sponsoring Agency Code	
16. Abstract Studies were conducted at three sites on Mitkof Island, Alaska, to determine the effects of three real or three simulated sonic booms of about 6 pounds per square foot over-pressure upon reproduction in farm-raised mink. Control animals were not boomed. No differences (P>.05) were found among experimental treatments for length of gestation, number of kits born per female whelping, number of kits alive per female at 5 and 10 days of age, weight of kits at 49 days of age, kit pelt value and selling price. A behavioral study showed no evidence that the female mink under observation were sufficiently disturbed by sonic booms to engage in kit packing, kit killing or to disrupt normal lactation. Results of necropsy examinations showed no mink deaths attributable to real or simulated sonic booms. Likewise, no evidence was found that bacterial disease was induced in the herd following exposure to sonic booms. There were no detectable differences in the overall health of the females at the three sites. The conclusion drawn from these studies is that exposure of farm-raised mink to intense sonic booms during whelping season had no adverse affect on their reproduction or behavior.			
17. Key Words Sonic boom - simulated sonic boom - mink reproduction - behavior - pathologic findings - virology - bacteriologic findings - physical environment		18. Distribution Statement Availability is unlimited. Document may be released to the National Technical Information Service, Springfield, Virginia 22151, for sale to the public.	
19. Security Classif. (of this report) Unclassified	20. Security Classif. (of this page) Unclassified	21. No. of Pages 239	22. Price \$3.00/pc \$ .95/mc

## PREFACE

With the development of supersonic aircraft came the possibility of physiological and psychological effects on humans and animals from sonic booms produced by these aircraft. Stress can adversely affect the production of domestic animals and claims have been filed against the Government for alleged damage caused by sonic booms.

During 1970, an interdisciplinary study was conducted by the U. S. Department of Agriculture (sponsored by the Federal Aviation Agency, Department of Transportation, under Inter-Agency Agreement DOT-FA 70WAI-171), the University of Alaska (under USDA Cooperative Agreement 12-14-100-10383 (44), and Biological support was provided by Washington State University under contract with the Air Force Office of Scientific Research on Mitkof Island, Alaska, to determine the effects of real and simulated sonic booms upon late pregnancy, parturition, early kit mortality, and subsequent growth of farm-raised mink (*Mustela vison*). Observers were from the National Academy of Sciences, U. S. Department of Interior, the Mink Farmers Research Foundation and the U. S. Air Force. The Chief of Staff, U. S. Air Force, directed that the Air Force provide the required ground and air support for the entire project. A Veterinary Medical Scientist/Toxicology (Special Project 69-27-USAF Environmental Health Laboratory) was assigned to assist in planning, finalizing of design, directing the production of a 16 mm movie of study, reviewing and securing Air Force clearance for the final report. Other Air Force scientists were assigned as study progressed. Headquarters, Alaskan Air Command, under AAC Operations Plan 8-69, Cool Mink, was assigned the responsibility of airlifting most supplies including test animals, communication and weather personnel and the aircraft for producing the sonic booms. The Federal Aviation Agency contributed substantially to the detail of designing the experiment, providing data on the magnitude and placement of the sonic boom, forming the basis for selection of sonic boom levels, the standardization of observing techniques, the onsite video, photographic and engineering support, and generally active participation in the experiment.

The reproduction phase was conducted upon 350 yearling and 148 2-year-old females and 1,845 progeny. The growth phase was conducted upon 90 male and 90 female kits. Treated mink received either three sonic booms of approximately 6 pounds per square foot overpressure or three simulated sonic booms of approximately 6 pounds per square foot on the day nearest the date when 40 percent of the females in each group had whelped. These booms were over a 60 minute period, the second following the first by 45 minutes and the third following the second by 15 minutes.

The physical environment and boom effects phase of the study reports boom overpressures and associated motions of the sheds and cages, which were recorded as continuous functions of time. They are discussed in terms of derived factors, such as peak overpressures, rise times and rates, and frequency and magnitude of structural vibrations. Related measurements, including weather conditions and ambient noise are discussed.

The behavioral phase observed the behavior of individual mink before and after real and simulated sonic booms to determine the nature and temporal duration of any observable behavior changes during whelping season that could be related to sonic boom exposure. The activity of arbitrarily selected female mink was observed and recorded during whelping season before and after exposure to real or simulated sonic booms. Daily observation periods lasted 3 hours and included the projected times of the real or simulated booms. Intra-group and inter-group comparisons were made in the frequency of occurrence of observable behavioral units. A close-circuit TV monitor was positioned above the nest box of one female with a litter on the day of the sonic booms. The camera continuously monitored the activity of the female mink and her kits inside their nest for 3 minutes before and 15 minutes after each boom. Three 16 mm cameras were used to record the reactions of 12 female mink prior to, during and after each sonic boom. The film capacity of the cameras was 1200 feet or 30 minutes of continuous coverage.

In the pathologic phase, necropsy examinations were conducted on all mink that died immediately before and after exposure to sonic booms. Gross examinations were done on 16 adult mink, 220 newborn kits, and 1 placenta. Tissues from all adult mink were saved for microscopic examinations, and 36 whole kits were saved as was the one placenta. Tissues were saved in 10 percent formalin and later prepared for microscopic examination at the Armed Forces Institute of Pathology.

The bacteriologic phase concerned bacteria isolated from skin abscesses or pustules and from necropsy specimens of animals that died or were sacrificed during the study.

Virological studies were carried out to investigate the presence of Aleutian disease, mink virus enteritis, canine distemper, and mink encephalopathy in the females and kits. The studies were divided into two general aspects. One was an evaluation of the females and kits at the sites. The clinical appearance of the animals, necropsy of dead females and kits and serum collection from females were carried out at this time. The second part of the investigations was evaluation of the serum and fetal tissues in the Veterinary Pathology Laboratory at Pullman, Washington.

This study could hardly have been accomplished without the excellent help of many people to whom I am deeply indebted. Particularly helpful were H. C. Bauer, W. B. Bell, P. K. Bowen, George Bromfield, Kenton Chittum, N. J. Chura, T. J. Clark, Mrs. Margaret C. Dennis, H. F. Drury, Miss Andrea Gershinou, W. R. Hinshaw, T. A. Howell, R. C. Inman, C. Kruse, T. A. Ladson, J. F. Lee, R. B. Lewis, Mrs. Anita R. Lozano, D. J. Maglieri, W. W. Martin, W. F. McCormack, W. W. Melvin, Jr., Mrs. Olga Y. Peeler, J. K. Power, J. O. Powers, Donald Randall, C. N. Robeson, R. A. Shepanek, Mrs. Linda S. Stanton, R. G. Stephenson, J. P. Sweeney, Mrs. Marguerite J. Taliaferro, J. P. Taylor, William Thurston, Mrs. Florence D. Toffon, D. W. Wustenberg. People who assisted by critical reading portions of the manuscript include D. Carter, D. A. Hilton, W. R. Hinshaw, W. W. Martin, W. L. McFarland, J. E. Oldfield, A. R. Seebass, and H. Teitelbaum. Their assistance is gratefully acknowledged.

Walter E. Brewer  
USAF Project Coordinator

James Bond  
Project Leader

## CONTRIBUTORS

James Bond, Project Leader and Research Animal Scientist, Ruminant Nutrition Laboratory, Institute of Nutrition, National Agricultural Research Center, ARS, Beltsville, Maryland 20705.

Walter E. Brewer, Chief, Veterinary Ecology-Toxicology Division, USAF Environmental Health Laboratory, Kelly AFB, Texas 78241.

Charles R. Curran, Principal Investigator, Armed Forces Radiobiology Research Institute, Defense Nuclear Agency, National Naval Medical Center, Bethesda, Maryland 20014.

James B. Henson, Chairman, Department of Veterinary Pathology, Washington State University, Pullman, Washington 99163.

Glenn A. Huttenhauer, Chief, Bacteriology and Serology Branch, Epidemiology Division, USAF School of Aerospace Medicine, Brooks AFB, Texas.

James K. Leekley, Research Biologist, University of Alaska, Petersburg, Alaska 99833.

John R. Menear, Agricultural Engineer, Agricultural Engineering Research Division, ARS, Beltsville, Maryland 20705.

Farrel R. Robinson, Chief, Veterinary Pathology Department, Armed Forces Institute of Pathology, Washington, D. C.

Hugh F. Travis, Leader, Fur Animal Investigations, Animal Science Research Division, ARS, Ithaca, New York 14850.

Ruel L. Wilson, Biometrician, Biometrical Services, ARS, Beltsville, Maryland 20705.

## CONTENTS

	Page
Effects of Real and Simulated Sonic Booms on Reproduction and Growth of Farm-Raised Mink by Hugh F. Travis, James Bond, Ruel L. Wilson, and James R. Leekley .....	1
Physical Environment and Boom Effects by John R. Menear .....	35
The Behavioral Response of Female Mink Exposed to Real or Simulated Sonic Booms by Charles R. Curran .....	85
Pathologic Findings in Adult and Newborn Mink ( <u>Mustela vison</u> ) Exposed to Real and Simulated Sonic Booms by <u>Farrel R. Robinson</u> , Walter E. Brewer, and Glenn A. Huttenhauer .....	133
Bacteriologic Findings in Adult and Newborn Mink Exposed to Real and Simulated Sonic Booms by Glenn A. Huttenhauer, Walter E. Brewer, and Farrel R. Robinson .....	208
Virology of Mink (Females and Kits) Exposed to Real and Simulated Sonic Booms (Project Cool Mink) by James B. Henson .....	218
Summary and Conclusions by James Bond .....	230

Numbers in parentheses refer to year of publication, literature citations, or references at the end of each report. The data presented in the references, figures, and tables are reproduced essentially as they were supplied by the author(s) of each report.

Effects of Real and Simulated Sonic Booms Upon Reproduction  
Growth of Farm-Raised Mink

Hugh F. Travis<sup>1/</sup>, James Bond<sup>2/</sup>, Ruel L. Wilson<sup>3/</sup>,  
and James R. Leekley<sup>4/</sup>

INTRODUCTION

The increasing levels of ambient noise produced by modern technology have led to concern about possible physiological and psychological effects to man and animals. This includes the effects of sonic booms produced by aircraft traveling faster than the speed of sound. With livestock, particular interest has been shown in the possible effects of sonic booms upon farm-raised mink which are believed to be easily disturbed, especially during the reproductive cycle (Pallen, 1944; Jensen, 1962; Mossin, 1962; Gjesdal, 1963; Grubb, Van Zandt and Bookholt, 1967; Hartsough, 1968; Pernu, 1968; Taylor, 1968). During the last decade, claims totalling thousands of dollars were filed against the U.S. Air Force for alleged damage to mink caused by sonic booms (Bell, 1970). On a dollar basis, this represents approximately two-thirds of the claims filed against the Air Force alleging damage to animals from noise or sonic booms.

LITERATURE REVIEW

General bibliographies and reviews on the effects of noise and sonic booms upon man and animals have been published (Loring, 1953; Busnel, 1963; Morozov, 1969; Bell, 1970; Kryter, 1970; NAS, NRC, 1970; Neher, et al., 1970; Welch and Welch, 1970). Several types of investigations have been pursued. One category is observations on the acoustical effects of sound (Ades, 1963; Anichin, 1964; Faltynek and Vesely, 1964; Beagley, 1965; Majeau-Chargois, Berlin and Whitehouse, 1970). Another category involves investigations in which sound was used at intensities and for durations which are generally considered to make it a nonspecific (Neher, et al., 1970) physiological stressor (Anthony, Ackerman and Lloyd, 1959; Sackler, Weltman and Jurtschuk, 1960; Jensen and Rasmussen, 1963; Anderson and Geber, 1967; and Friedman,

---

<sup>1/</sup> Leader, Fur Animal Investigations, U. S. Department of Agriculture, ARS, Ithaca, New York 14850.

<sup>2/</sup> Research Animal Scientist, U. S. Department of Agriculture, ARS, Beltsville, Maryland 20705.

<sup>3/</sup> Biometrician, Biometrical Service Staff, U. S. Department of Agriculture, ARS, Beltsville, Maryland 20705.

<sup>4/</sup> Research Biologist, University of Alaska, Petersburg, Alaska 99833.

Byers and Brown, 1967). In these studies extraauditory effects, such as alterations of endocrine function, growth, and reproduction, have been observed. While research of this type demonstrates that intense and prolonged sound can induce stress responses, it leaves mostly unanswered questions such as: what are the thresholds of intensity and duration required to induce adverse responses, the species differences, and the comparative effects of sound and other stressing agents in a normal life situation?

A third category of observations attempted to relate the effects of real or simulated sonic booms or low-flying aircraft overflights to subsequent animal behavior or performance (Bolt, Beranek and Newman, Inc., 1965; Nixon, et al., 1968; Heinemann, 1969; Bond, 1970; Robertson, 1970). While these investigations give information about the species studied, it is difficult to directly relate this information accurately to another species, particularly to one so different from most domestic livestock and laboratory animals as the mink.

The literature on the effects of loud noises and sonic booms upon mink is limited. Kull (1962) reported a study conducted in which the Swedish Air Force made low-level (50-150 meter) subsonic flights over mink farms during the whelping period (May 9-18). There was no loss of mink kits. The animals noticed the flights, and one blocked the entrance to the nest box with straw. Two females brought kits out from the box, but returned them. The conclusion was: "Further tests are required." Heinemann (1967) reported the results of "Project Mink Boom" carried out in Minnesota during the winter and spring of 1967 by the United States Air Force. The aircraft flew at 11,480 - 13,120 meters on regular training flights at speeds ranging from Mach 1.32 to 2.01. The sonic booms caused brief "alerting reactions." Nine booms were made during the breeding phase, and six during whelping. At that time, the owners said the mink had not been disturbed by the noise, but later reversed this statement. The author believed that the mink did not react to the sonic booms more than to other sights and sounds near the ranch.

Travis et al., (1968) conducted studies on two southern Virginia mink farms using the same device for producing simulated sonic booms that was used in the present study. (See the Physical environment and boom effects section of this report). Different groups of mink were "boomed" at random times eight times daily from April 8 to April 18, from April 18 to June 1, or from April 8 to June 1. One hundred and sixty-three "boomed" females had an average litter size of 4.4 at 10 days compared to an average litter size of 4.5 for 94 mink which were not "boomed." Kit mortality to 10 days averaged 7.2 percent for the control group and 8.6 percent for the "boomed" groups. They concluded that reproduction in both the "boomed" and "not boomed" groups could be considered normal.

None of the above studies gave definitive answers to the effects of real sonic booms upon mink when first experienced during the middle of the whelping season. They were designed to answer other questions, animals were subjected to real or simulated booms prior to whelping, or simulators were used.

Tremendous amounts of effort, cooperation, scientific manpower, and facilities are needed to satisfactorily investigate the effects of real sonic booms on mink. Among others, these include a mink herd of several hundred breeding females, an isolated study area of approximately 104,000 hectares which can be boomed at will, an adjacent area for control mink that is not boomed, adequate instrumentation, and control of the aircraft which will be booming the animals. The current investigation is the first study in which funds, personnel, and facilities were available for a definitive investigation with adequate controls using actual measured sonic booms of high magnitude at approximately the middle of the whelping season on mink that had not been boomed prior to the test booms.

#### PROCEDURES

The study was conducted on Mitkof Island near Petersburg, Alaska, (Figure 1) home of the University of Alaska Fur Animal Experiment Station. This location satisfied the necessary conditions for such a study: (1) an area where mink could be raised successfully and not be subjected to sonic booms, (2) an established fur animal experiment station with trained personnel to use as a control site, (3) isolated areas for use as test sites where mink could be boomed without exposing the control mink, (4) a location where the isolation would eliminate possible disturbance to people and structures from the sonic booms, and (5) good roads connecting the control and boom site so that similar management could be maintained at both sites. Attempts were unsuccessful to find an area that met these criteria within the contiguous 48 States.

Locations of the sites on the island are shown in Figure 2. Aerial photographs of the control, simulator and real boom sites are shown in Figures 3, 4 and 5, and scale drawings of the control and real boom sites are shown in Figures 6 and 7.

In general, the sites were comparable with the exception that the boom site was more exposed to the prevailing winds than the other sites. Due to the isolation, a caretaker lived at the boom site. The original caretaker resigned on May 22 and was replaced on May 23, 1970.

Mink recessive for the Aleutian gene (al) were used for the study as they are more difficult to raise than mink not recessive for this gene and thus would give a more stringent test of possible harmful effects. Mink recessive for the Aleutian gene constituted about one-fourth of all mink raised in the United States in 1970 (USDA 1971).

The experimental animals were purchased under open bid contract by the University of Alaska. The contract specified that they all come from one farm, all be of the same color phase, be homozygous for the recessive Aleutian genes (al), have been inoculated against distemper, and be negative for the iodine agglutination test for Aleutian disease.

The mink (500 females, 130 males) were purchased from an established farm (Harvey Ronne, Salem, Ore.) in January 1970. They were of violet color phase (pp alal bmbm), recessive for platinum, Aleutian and Moyle-Olsen buff (Shackelford, 1971). They were shipped from Salem to Petersburg on January 17, 1970, by USAF C130 cargo plane and divided at random into three groups at the time of delivery. The three treatments were: (1) control group, which was not boomed, (2) simulator group, which was subjected to simulated booms (5.84 pounds per square foot (psf) mink closest to simulator, most distant received 1.6 psf and at midpoint of shed received 3.5 psf), and (3) the boomed group, which was subjected to real sonic booms (averaging 5.05 psf, range 6.6 to 3.6). In addition, mink receiving the sonic boom were subjected to a dynamite blast on the day of the boom, 25 minutes following the third real sonic boom. The location of the sites was such that neither the real nor simulated sonic booms could be heard at either of the other two locations. This was verified on the days of the booms by observers stationed at the sites not receiving the treatment. For details see Physical environment and boom effects, and behavior sections. There were both yearling females, born in 1969, and 2-year-old females, born in 1968, assigned to each treatment group. Two hundred females and 50 males each were randomly assigned to the control group and to the group to be boomed. One hundred twenty females and 30 males were randomly assigned to the group which was to receive the simulated booms.

As nearly as possible, all mink were handled in a like manner. Animals were housed in standard mink pens and sheds, Figures 8, 9, 10, 11. All mink received the same feed (Table 1), which was mixed daily at the control site and trucked to the boom and simulator sites. Animals were watered twice daily, bedding was checked every 2 to 4 days, and wild native hay free of thistles, awns, and other irritating material was added as needed. On April 22 all females were bedded with sugarcane bagasse which was used until all kits were weaned.

TABLE 1.--Diets Fed and Analyses of Diets Fed During  
1970 Sonic Boom Study

% of Ration Before Water Added	Feb. 1	Mar. 2	May 1	July 8	July 15	July 20	Aug. 2	Oct. 1
	to	to	to	to	to	to	to	to
	Mar. 1	April 30	July 7	July 14	July 19	Aug. 1	Sept. 30	Pelt
Frozen Salmon Heads <sup>1/</sup>	38.9	38.9	38.9	38.9	38.4	38.4	38.9	38.9
Frozen Halibut Waste	22.2	22.2	22.2	11.1	16.5	16.5	16.7	16.7
Frozen Whole Flounder	22.2	16.7	16.7	22.2	22.0	22.0	22.2	27.7
Frozen Beef Liver	---	5.5	5.5	11.1	5.5	5.5	5.5	---
Kellogg's Cereal (1009)	---	---	16.7	16.7	16.5	16.5	16.7	16.7
Custom Dry Mix	15.6	15.6	---	---	---	---	---	---
Cotton Seed Oil	---	---	---	---	1.1	---	---	---
Hydrogenated Vegetable Shortening	---	---	---	---	---	1.1	---	---
Beet Pulp	1.1	1.1	---	---	---	---	---	---
Sample Date	Feb. 1	May 27	July 14	July 15	July 20			
Protein	38.26	34.30	36.76	38.93	37.10			
Fat	22.75	24.73	20.37	21.24	25.02			
Fiber	1.77	2.35	2.23	2.45	2.36			
Ash	7.92	9.06	7.64	7.50	8.04			
N.F.F.	29.30	29.56	33.00	29.88	27.48			
Calcium	2.55	3.05	2.47	2.40	3.12			
Phosphorus	1.03	1.39	1.10	1.30	1.29			

<sup>1/</sup> 19 g of vitamin E (44,092 I.U./kg) added to each 45.359 kg of feed as fed from February 1 to August 1.  
From August 2 to pelting 29 g per 45.359 kg was added. Oxytetracycline (22 g/kg) was added at a level  
of 16 g per 45.359 kg feed as fed to the mink.

The breeding season was initiated on March 13 and continued until April 5. Males were carried to females. General practice was to attempt to remate females on days eight and nine after the first mating until March 20. After March 20 an attempt was made to mate previously unmated females on two consecutive days. Starting on April 25 the nest box of each female was checked daily until all litters were 10 days old (June 1).

All kits were counted on the mornings of the boom and simulator days (May 11, May 12) prior to the real booms or simulated booms. An additional count was made of mink in odd-numbered pens in all experimental groups immediately after the series of three real booms was completed on boom day, and a count was made in the even-numbered pens of all groups immediately after the three simulated booms were completed on simulator day. Thus, all mink were counted three times in two days (in the morning of each day and in the afternoon of either boom or simulator day). The purpose of this arrangement was to allow observation of the effects of the real booms and simulated booms immediately after they occurred while at the same time not causing disturbances to the mink through additional counting which might disproportionately affect one group or another.

Thirty male and 30 female kits were randomly selected from each treatment to be raised under similar conditions to evaluate possible differences among treatments on kits raised to pelting. All kits were weighed and weaned, and kits from the boomed and simulator groups were moved on the date when they were 49 days of age to the control site where all mink were raised to pelting. Final weights, final body lengths, pelt value and selling price were taken on all animals in each group. Weights of anterior pituitary, thyroid, adrenal, testes and ovaries were taken on 10 males and 10 females randomly selected from each group.

Final body length was measured on the animal immediately after killing by laying the animal on a table, stretching, and measuring from tip of nose to base of tail. Pelt values were the appraised value of the Seattle Fur Exchange professional graders based on January 1971 prices. Selling prices were the actual selling prices on the February 3, 1971 sale.

Organ weights are reported in Table 2 on a basis of mg/kg of body weight.

The majority of the traits measured were unbalanced and thus analyzed for differences, using a generalized analysis of variance procedure for unequal subclass numbers (Harvey, 1960).

TABLE 2.--Mean Body Weights, Pelt Values and Organ Weights  
of Kits on Sonic Boom Study Raised to Pelting

	Body Weight 8/3/70	Final Body Weight	Final Length	Pelt value \$	Selling price \$	Pituitary	Thyroid	Adrenal	Testis	Ovaries
	g	g	cm				mg/kg	Body Weight		
Total Experimental Mink	180	176	176	176	174	60	60	60	30	30
Control										
Males	1052	2118	46.15	14.57	16.73	4.2	43.5 <sup>b</sup>	57.2	371.7	--
Females	771	1161	39.04	6.91	8.50	4.6	50.8	59.0 <sup>a</sup>	--	84.4 <sup>a</sup>
Average	912	1642	42.60	10.74	12.62	4.4	47.1	58.1	--	--
Simulated Booms										
Males	1030	2082	45.77	14.40	16.48	4.0	33.7 <sup>a</sup>	60.0	428.1	--
Females	739	1102	38.25	6.64	8.22	4.4	48.6	57.9 <sup>a</sup>	--	96.4 <sup>a,b</sup>
Average	885	1592	42.01	10.52	12.35	4.2	41.2	58.9	--	--
Real Booms										
Males	1061	2068	45.11	14.59	16.40	4.4	33.6 <sup>a</sup>	55.6	459.0	--
Females	762	1152	37.80	6.92	8.58	4.9	48.2	70.5 <sup>b</sup>	--	107.9 <sup>b</sup>
Average	912	1610	41.45	10.76	12.49	4.7	40.9	63.0	--	--

a, b Means having unlike superscripts are different P<.05. See text for standard errors of significantly different means.

Based on the number of females whelping, length of gestation, whelping date, number kits born, born alive, alive at 5, 10 and 49 days were subjected to the following model:

$$Y_{ijkl} = \mu + T_i + A_j + (TA)_{ij} + P_k + (TP)_{ik} + (AP)_{jk} + (TAP)_{ijk}$$

+  $e_{ijkl}$  where:

$Y_{ijkl}$  is an effect common to the  $l^{\text{th}}$  observations in the particular  $ijk^{\text{th}}$  classification;

$\mu$  = the overall mean when equal subclass frequencies exist;

$T_i$  = an effect due to the  $i^{\text{th}}$  treatment;  $i = 1-3$ ;

$A_j$  = an effect due to the  $j^{\text{th}}$  age of mother dam;  $j = 1-2$ ;

$P_k$  = an effect due to the  $k^{\text{th}}$  period (pre or post boom);  $k = 1,2$ ;

$e_{ijkl}$  = random error assumed to be independent and normally distributed;

plus interactions of the above main effects as shown in the model.

Kit weight at 49 days was analyzed as a split plot with main effects and interactions in the above model used as main plot effects along with a linear regression for litter size. The subplot (adjusted for litter differences) contained the effect of sex and interactions of sex with main plot effects.

The model for the 180 kits raised to pelting contained treatment, age of mother, and sex of kit effects plus interactions. Due to the limited number, the organ weights were analyzed for treatment and sex effects for the combined analyses or treatment effects alone for these traits common to a particular sex.

## RESULTS AND DISCUSSION

Booms of 6 pounds per square foot (psf) were selected to be tested for the following reasons: The earlier simulated test (Travis *et al.*, 1968) had been conducted on the basis of a 2 psf boom with resultant normal productivity. There is a reasonable possibility of the occurrence of tripling the sonic boom levels at a particular point due to terrain, atmospheric, and aircraft maneuvering effect. The "nominal" sonic boom levels projected for civil supersonic aircraft are on the order of 2 psf. Therefore, multiplication by a factor of 3 would give a possibility of occurrence of a 6 psf boom caused by civil aircraft if supersonic flights were permitted. If the sonic boom levels selected were too high, for example, 10 to 12 psf, it would have been very

difficult to project downward to a lower value to determine whether this would have disturbed the mink. Since it was unlikely that a civil aircraft would cause a sonic boom at more than 6 psf, it was considered more important to check at the lower value, at which there was a possibility of occurrence; and it was not considered advisable to conduct the experiment on a basis of a series of sonic booms at varying levels, because it was considered possible that the mink would adapt or become habituated.

Breeding, whelping, and early kit performance are summarized in Table 3.

The experiment was designed for the booms to occur when approximately half of the bred mink (at an expected 80 percent whelping rate) had whelped. This allowed observations of boom effects on both nursing mothers and females that had not yet whelped. This procedure automatically divided each group into "early whelpers" and "late whelpers." Because of this, it was not possible to determine the percentage of females that might have whelped of the mink that were segregated into pre- or post-boom groups, as all of the nonproducers automatically fell into the post-boom category.

Approximately one-fourth of the mink on each treatment were yearling females that had not whelped previously, and three-fourths were 2-year-olds that had produced a litter the previous year. Possible differential performance of these different subgroups was considered in the design and did occur. This, along with the variability of reproductive performance in the mink, explains the large numbers of animals required to conduct an experiment of this nature.

Statistical evaluation of reproductive performance was made on the basis of kits per female whelping rather than per female on experiment because the percent of females whelping among treatments was not substantially different, and conception was initiated before the experimental treatments. The percentage of females whelping ranged from 76.8 to 82.6 percent for all treatment-age groups except 2-year-old mothers in the simulated group, where 69.4 percent whelped (table 3).

Mean Date of Last Mating. The least-squares mean date of last mating was day  $85.77 \pm 0.28$  for the controls, day  $85.84 \pm 0.39$  for the simulator group and day  $85.72 \pm 0.28$  for those receiving the real booms (March 26 = day 85). There was no significant difference among experimental treatments or between age classes. There was a period difference ( $P < 0.01$ ), with the mean mating date of mink that whelped pre-boom being earlier than those whelping post-boom or simulation ( $84.34 \pm 0.20$  for mink whelping pre-boom or simulation and  $87.23 \pm 0.24$  for mink whelping post-boom or simulation). A significant age-by-period difference ( $P < 0.01$ ) was noted in the simulator group. Two-year-

Table 3. Reproductive and Early Kit Performance 1

	No. females on expt. May 5	No. females whelped	Percent females whelped	Av. 2 breed date	Av. 3 whelp date	Av. gest. time	Number of Kits				Kits/Female Whelp				49 day wt.			
							born alive	born	10 days	49 days	born alive	born	5 days	10 days		49 days		
(Control)																		
Total	195	158	79.8	85.8	131.5	45.7	726	649	516	497	442	4.59	4.11	3.27	3.15	2.80	357	
Mothers born 1968																		
(2-year-olds)	56	43	76.8	85.7	131.6	45.9	188	176	138	128	114	4.37	4.09	3.21	2.98	2.65	371	
Mothers born 1969																		
(yearlings)	139	115	82.7	85.8	131.4	45.6	538	473	378	369	328	4.68	4.11	3.29	3.21	2.85	342	
Mothers whelped pre-booms	--	4	--	84.4	128.8	44.4	435	387	317	310	280	4.94	4.40	3.60	3.52	3.18	361	
Mothers whelped post-booms	--	70	--	87.1	134.2	47.1	291	262	199	187	162	4.16	3.74	2.84	2.67	2.31	353	
(Simulated booms)																		
Total	114	89	78.1	85.8	132.6	46.8	374	333	280	272	249	4.20	3.74	3.15	3.06	2.80	346	
Mothers born 1968	36	25	69.4	85.7	132.5	46.8	86	66	41	39	37	3.44	2.64	1.64	1.56	1.48	347	
Mothers born 1969	78	64	82.1	86.0	132.7	46.7	288	267	239	233	212	4.50	4.17	3.73	3.64	3.31	344	
Mothers whelped pre-simulations	--	50	--	84.3	129.9	45.6	223	195	162	156	148	4.46	3.90	3.24	3.12	2.96	349	
Mothers whelped post-simulations	--	39	--	87.4	135.3	47.9	151	138	118	116	101	3.87	3.54	3.03	2.97	2.59	326	
(Real booms)																		
Total	189	156	82.5	85.7	131.6	45.9	745	657	497	481	434	4.78	4.21	3.19	3.08	2.78	344	
Mothers born 1968	56	46	82.1	85.5	131.5	46.0	202	184	139	135	118	4.39	4.00	3.02	2.93	2.57	352	
Mothers born 1969	133	110	82.7	85.9	131.8	45.8	543	473	358	346	316	4.94	4.30	3.25	3.15	2.87	336	
Mothers whelped pre-booms	--	83	--	84.4	129.1	44.7	410	355	267	255	232	4.94	4.28	3.22	3.07	2.80	381	
Mothers whelped post-booms	--	73	--	87.1	134.1	47.0	335	302	230	226	202	4.59	4.14	3.15	3.10	2.77	326	

1-See text for standard errors of significantly different means.

2-March 26 = Day 85.

3-May 11 = Day 131.

4-The date the females whelped determined whether they were in the pre- or post-boom group. Thus, it was impossible to categorize nonproducers.

old females whelping pre-simulated boom had a mean mating date of  $83.06 \pm 0.76$ , while 2-year-old females post-simulated boom averaged  $88.25 \pm 1.10$ , a difference of 5.2 days. Yearling females whelping pre-simulated boom were mated on day  $85.54 \pm 0.54$ , while yearling females whelping post-simulated boom had an average mating date of  $86.52 \pm 0.56$ , a difference of 1.0 days.

Mean Whelping Date. The least-squares mean whelping date for all mink was day  $131.91 \pm 0.11$  (May 11 = day 131). Whelping date was significantly different ( $P < 0.01$ ) among treatments. Mink from the simulator site ( $132.62 \pm 0.24$ ) whelped significantly later than control mink ( $131.50 \pm 0.18$ ) or real boom mink ( $131.61 \pm 0.17$ ). The mean whelping date of mink whelping pre-boom or simulation was  $129.28 \pm 0.15$ , and the mean whelping date of mink whelping post-boom was  $134.55 \pm 0.18$ . There was an age by period interaction ( $P < 0.05$ ) with the 2-year-olds having an earlier average whelping date pre-boom ( $128.92 \pm 0.25$ ) and a later average whelping date post-boom ( $134.77 \pm 0.31$ ) than the yearlings ( $129.63 \pm 0.16$  pre-boom, and  $134.32 \pm 0.17$  post-boom).

Mean Length of Gestation. Gestation length was considered to be the interval between last mating and whelping date. The mean length of gestation for all mink was  $46.13 \pm 0.20$  days. Difference among treatments was not statistically significant. However, gestation in simulator group was almost a day longer than in the others. This increased length of gestation in the simulated boom group manifested itself in a significantly later whelping date, a day or slightly more than a day later than the means of the other two groups. The biological significance is unknown. The trend had already established itself before the simulated booms, since the date when 40 percent of the females had whelped was one day later than for the other groups. Any differences among treatments occurring before the booms or simulated booms must be attributed to factors other than the treatments.

There was a significant difference ( $P < 0.01$ ) in length of gestation between those females that whelped early (pre-real or simulated sonic booms,  $44.93 \pm 0.25$ ) and those females that whelped late (post-real or simulated sonic booms  $47.32 \pm 0.30$ ). This phenomenon is to be expected. The gestation period of mink varies because of a variable period of delayed implantation. Therefore, it is logical to expect those mink that whelped pre-boom have shorter gestation periods.

Number of Kits Born per Female Whelping. The least-squares mean number of kits born per female whelping was  $4.46 \pm 0.19$  for the control group,  $3.89 \pm 0.26$  for the simulator group and  $4.62 \pm 0.18$  for the boomed group, with no significant difference among treatments. The litter size of yearlings ( $4.68 \pm 0.13$ ) was different ( $P < 0.01$ ) from that

of 2-year-old mothers ( $3.97 \pm 0.21$ ). This was most apparent in simulator group (2-year-olds  $3.29 \pm 0.44$ , yearlings  $4.49 \pm 0.26$ ) but was also evident in the control group (2-year-olds,  $4.27 \pm 0.32$ , yearlings  $4.65 \pm 0.19$ ) and the real boom group (2-year-olds,  $4.35 \pm 0.31$ , yearlings,  $4.89 \pm 0.20$ ). A period effect ( $P < 0.05$ ) was also found. Mink whelping pre-boom averaged  $4.60 \pm 0.16$ , and mink whelping post-boom averaged  $4.04 \pm 0.19$ .

Number of Kits Born Alive per Female Whelping. The least-squares mean of all kits born alive per female whelping was  $3.82 \pm 0.13$ . There were significantly ( $P < 0.05$ ) fewer kits born alive to the 2-year-old mothers in the simulator group ( $2.40 \pm 0.46$ ) than in any other treatment x age group. This same group had the smallest litter size at birth, the lowest percentage survival at birth, 5-days, and 10-days. Poorer production of 2-year-olds in the simulator group was somewhat offset by the performance of the yearling mothers, which had the highest kit survival rate of any group at 5 and 10 days. The biological bases for these phenomena are not known.

Number of Kits at 5 Days of Age per Female Whelping. The number of kits per female whelping in the 5-day count was not statistically different among treatments. There was an age difference ( $P < 0.01$ ) with yearling mothers having least-squares means of  $3.40 \pm 0.13$  kits per litter compared to  $2.49 \pm 0.22$  for 2-year-olds. A treatment x age interaction ( $P < 0.01$ ) resulted from the low average number of kits alive at 5 days of 2-year-old females in the simulator group. This was also true at 49 days. Litter sizes in the control, simulator, and boomed groups for 2-year-olds were  $3.11 \pm 0.34$ ,  $1.40 \pm 0.46$  and  $2.49 \pm 0.32$  whereas yearlings averaged  $3.26 \pm 0.20$ ,  $3.73 \pm 0.27$  and  $3.21 \pm 0.21$  respectively.

Number of Kits at 10 Days of Age per Female Whelping. The least-squares means per female whelping were  $3.01 \pm 0.20$ ,  $2.49 \pm 0.27$  and  $2.98 \pm 0.19$ , respectively, for the control, simulator, and boomed groups. The age effect was significant ( $P < 0.01$ ), yearlings having a litter size of  $3.31 \pm 0.13$  and 2-year-olds  $2.35 \pm 0.22$ . This was mainly because of the significant ( $P < 0.01$ ) treatment x age interaction with poorer performance of 2-year-old females in the simulator group. There was also a significant ( $P < 0.05$ ) treatment x period interaction. Litter sizes in the boomed group were larger from females that whelped post-boom ( $3.11 \pm 0.26$ ) compared to females whelping pre-boom ( $2.79 \pm 0.28$ ). However, litter sizes were larger from females whelping pre-boom in the simulator group ( $2.83 \pm 0.32$ ) compared to post-boom ( $2.15 \pm 0.43$ ) and in the control group pre-boom ( $3.50 \pm 0.25$ ) compared to post-boom ( $2.52 \pm 0.30$ ). The percent survival of kits at 10 days for each whelping date for each treatment is shown in Figure 12. Survival by date was variable among the experimental treatments. There did not appear to be a cause and effect relationship between kit survival and the treatments on or immediately after boom and simulator days. There was very little change in 49 day survival patterns compared to 10 day survival patterns.

Pre and Post Boom Kit Counts. Kits in odd numbered pens were counted prior to and immediately after the last booms on boom day, and kits in even numbered pens were counted in the same manner on simulator day. Results on boom day were as follows: for the control group, 172 pre boom and 191 post boom (22 born, 3 died); for the simulator group, 96 pre boom and 96 post boom (2 born, 2 died); and for the group receiving the actual sonic booms, 172 pre boom and 185 post boom (13 born, none died). On simulator day the respective counts in the even numbered pens were: for the controls, 215 pre boom and 223 post boom (8 born, none died); for the group receiving the simulated booms, 79 pre boom and 96 post boom (17 born, none died); and for the boomed group 148 pre boom and 175 post boom (31 born, 4 died). There was no evidence of disrupted nest boxes, attempts of mothers to bury kits in the bedding, or undue handling of the kits by their mothers.

Mean Kit Weight at 49 Days of Age. There were no significant differences among treatments for weaning weight at 49 days of age. Males were significantly ( $P < 0.01$ ) heavier than females, which was as expected. There was also a significant negative regression ( $P < 0.01$ ) for weaning weight on litter size with weight decreasing 8.32 grams for each additional kit per litter.

Final Weight, Final Length, Pelt Value, Selling Price. Analysis of variance of final weight, final length, pelt value, and selling price did not show any statistically significant differences among treatments (Table 2).

Organ Weights. Organ weights for the pituitary, thyroid, adrenal and testes or ovaries were taken from 10 males and 10 females in each treatment (Table 2). Analysis of variance did not show any statistical differences in the weights of the pituitary or testes on a mg/kg body weight basis.

There was a sex by treatment difference in adrenal weights with no significance between the males of the three groups (57.6 mg/kg average) and the females of the control and simulator groups (58.5 mg/kg). However, the females in the boom group were significantly ( $P < 0.05$ ) heavier at  $70.5 \pm 2.97$  mg/kg. The ovaries of females in the boomed group ( $107.9 \pm 6.0$ ) were also significantly heavier ( $P < 0.05$ ) than control mink ( $84.4 \pm 6.0$ ). Ovaries of the mink in the simulator group were intermediate in size ( $96.4 \pm 6.0$ ) and not significantly different than either the boomed or control groups.

The magnitude of difference in the means and variances of thyroids for males and females adjusted to a mg/kg body weight basis was such that a separate analysis was conducted for each sex. The mean weight for females was 49.2 mg/kg with no significant difference for treatments. There was a significant ( $P < 0.05$ ) difference among the treatments for males with the control groups having larger thyroids ( $43.5 \pm 2.49$ ) than either the simulator ( $33.7 \pm 2.49$ ) or real boom ( $33.6 \pm 2.49$ ) groups. Forty-eight pastel mink (24 of each sex) measured at the U. S. Fur Animal Experiment Station, Ithaca, N. Y. averaged  $43.9 \pm 1.94$  for the females and the males averaged  $33.6 \pm 1.43$  which compares with the values of the simulator and real boom groups of this experiment.

Ambient Noise. The ambient noise level probably was comparable to that on an average ranch in the United States located near a road. The road, gravel-surfaced, was 84 meters from the closest mink at the control site and 98 meters from the closest mink at the boom site.

Logging operations being conducted about 3.2 kilometers from the boom site included intermittent blasting starting February or March 1970. The caretaker at the site reported that one blast in March caused an "alerting reaction" followed by retreat of the mink to the nest box. The caretaker also observed the alerting reaction and retreat to the nest box from occasional dropping of the cage tops during the breeding season and from the dropping of a garbage can lid on approximately April 15. (See Physical environment and boom effects Section for Measurements of Ambient Noise).

General Health. The general health of the experimental mink herd was below average. There were two primary predisposing factors. One was the selection of mink recessive for the Aleutian gene.

Mink homozygous for the Aleutian gene are less hardy, have more difficulty combatting bacterial infections, and are more difficult to raise than mink not containing this gene because of the presence of abnormal leucocytes which are related to the coat color (Leader, Padgett and Gorham, 1963; Padgett et al., 1964; Padgett, et al., 1967).

The second factor was the inadvertant exposure of the experimental herd to a situation where such an infection could develop.

To quote a letter from Mr. Harvey Ronne, the previous owner of the mink to one of us (Leekley) dated April 1, 1971 "... as for the boil problem. It started October 1969 about 2 weeks after I bedded the mink with a Chewings' fescue straw which we purchased from a grass seed farmer in the Salem area. Carl Fisketjon and I used the same straw and began having boil trouble the same time, so we obviously suspected the straw... No trouble was observed with the pastel or dark types".

Thus it is apparent that the boil problem arrived in Alaska with the mink. It is interesting to note that both on the home mink farm and while at the Alaska Agricultural Experiment Station Farm the boil problem was confined to the violet color phase of mink and did not spread to mink of other colors. In the Alaska Experiment Station herd of dark mink which was housed at the control site there were 115 females of which 96 whelped and had 403 kits averaging 367 grams at 7 weeks of age. During the period that the control mink for the sonic boom study were housed adjacent to the experiment station herd there were no abscesses in the darks and three possible cases of pneumonia. Seven mink kits from the experiment station herd were lost between the 10-day and 49-day counts.

The overall effects of the abscess and pneumonia problems were to place an additional stress on the mink used in the study. While this led to greater mortality and generally poorer reproductive performance and growth than could be expected under normal conditions, it could also be considered an advantage in terms of the overall evaluation of the results of the sonic boom test. An effort was made to select those mink that would be most likely to respond adversely to sonic booms, if mink were to respond. Thus, the added stress of these health problems, which appeared to be spread uniformly throughout the experimental treatments, should have given a greater sensitivity to adverse effects of the sonic booms, if there were to be such a response.

#### CONCLUSIONS

A study was conducted on Mitkof Island, Alaska, in 1970 to determine the effects of real and simulated sonic booms upon late pregnancy, parturition, early kit mortality, and subsequent growth of farm-raised mink. The reproduction study was conducted with 350 yearling and 148 2-year-old females and their 1,845 progeny. The growth study was conducted using 90 male and 90 female kits. Treated animals received either three sonic booms averaging 5.05 pounds per square foot (range 6.6 to 3.6 psf) over-pressure or three simulated sonic booms (5.84 psf mink closest to simulator, most distant received 1.6 psf and at midpoint of shed received 3.5 psf) on the day approximately 40 percent of the females in each group had whelped. These booms were given over a 60-minute period, the second following the first by 45 minutes, and the third following the second by 15 minutes.

The mean length of gestation or the mean date of last mating was not significantly different among experimental treatments. Because of the design of the experiment, those mink that whelped post-boom or post-simulation were bred later and had longer gestation periods than those mink that whelped pre-boom or pre-simulation. This was to be expected.

The mean whelping date was approximately one day later (P 0.01) for mink in simulator group (day 132.6 0.24) than for the control (day 131.5 0.18) and real boom groups (day 131.6 0.17). The biological significance is unknown. The trend was already established before the mink received the simulated booms. They were also one day later than the other two groups in obtaining a 40 percent level of whelping so that they could receive the experimental treatment.

The number of kits born per female whelping was not significantly different among treatments. Yearling mothers had a larger litter size than 2-year-olds, especially in the simulator group. Litter size also tended to be smaller post-boom in all treatments, but was not as great in the real boomed group. Number of kits born alive per female whelping was not significantly different for the control and boomed groups. The simulator females had fewer kits born alive (P 0.05) than the mothers in the controls or boomed groups because of the poorer performance of the 2-year-old mothers in the simulator group. The biological significance is unknown.

The number of kits alive per female at 5 and 10 days of age was not statistically different among experimental treatments. However, the 2-year-old mothers in the simulator group had poor performance which tended to be offset by the superior performance of the yearling mothers in the same group.

Visual observation of the odd numbered nests post boom on boom day, and the even numbered nests post simulation on simulation day did not show evidence of disrupted nest boxes, attempts of mothers to bury kits in the bedding, or undue handling of the kits by their mothers.

Mean weights of the kits at 49 days of age was not statistically different for the three experimental treatments.

No statistical difference was found among the 30 female and 30 male kits of each treatment that were raised to pelting in final weight, final body length, pelt value, and selling price.

Weights of their testes or pituitaries were not different among the 20 mink from each treatment. The adrenals of the females in the boomed group were heavier than those of the control and simulator groups. The ovary weights for the boom group were significantly heavier than the controls but not from the ovaries of the simulator group which were intermediate in weight. There were no significant differences among treatments for the thyroid weights of females. The thyroid weights from males of the simulator and real boomed groups were significantly smaller than those of the control group, but were not different from thyroids of 24 normal pastel males.

General health and productivity of the animals were below average. The selection of mink recessive for the Aleutian gene (al) and their inadvertent exposure, prior to the initiation of the study, to conditions which would cause abscesses explain their poorer performance. Unfortunately, an outbreak of hemorrhagic pneumonia in all three groups also contributed to the below average health of the mink in this study. These effects were spread evenly throughout the different treatments and were not affected by the simulated or real sonic boom treatment.

## LITERATURE CITED

1. Ades, H. W.  
1963. Structural changes in the organ of Corti produced by exposure to noise. *Anat. Rec.* 145:197-198.
2. Anderson, T. A., and Geber, W. F.  
1967. Abnormal fetal growth in the albino rat and rabbit induced by maternal stress. *Biol. Neonat.* 11:209-215.
3. Anichin, V. P.  
1964. On the localization and activity of acetylcholinesterase in the organ of Corti on animals under the effect of powerful high-frequency and medium-frequency sounds. *Vestn. Otorinolaryng.* 26:9-14.
4. Anthony, A., Ackermann, E., and Lloyd, J. A.  
1959. Noise stress in laboratory rodents. I. Behavioral and endocrine response of mice, rats and guinea pigs. *J. Acoust. Soc. Amer.* 31(11):1430-1437.
5. Beagley, H. A.  
1965. Acoustic trauma in the guinea pig. I. Electrophysiology and histology. *Acta Oto-Laryngologica (Sweden)* 60:437-451.
6. Bell, W. B.  
1972. Animal response to sonic booms. *J. Acoust. Soc.* 51:758.
7. Bolt, Beranek and Newman Inc.  
1965. Human response to sonic booms. Final report. Contract: DOT-FA69WA-2103. Project No. PR-69 5/WA5R-9-0188. 115 pp.
8. Bond, J.  
1970. Effects of noise on the physiology and behavior of farm-raised animals. In *Physiological Effects of Noise.* 295-305. Plenum Press.
9. Busnel, R. G. Editor.  
1963. *Acoustical Behavior of Animals.* Elsevier Publishing Company, New York.

10. Faltynek, L., and Vesely, C.
  1964. Effect of short-term sonic exposure on the microphone potential of guinea pigs. *Cesk. Otolaryng (Prague)* 13:313-317.
11. Friedman, M., Byers, S. O., and Brown, A. E.
  1967. Plasma lipid responses of rats and rabbits to an auditory stimulus. *Amer. J. Phys.* 212:1174-1178.
12. Gjesdal, F.
  1963. Panic injuries in fur farms. *Nord. Vet. Med.* 15:57-78.
13. Grubb, C. A., van Zandt, J. E., and Bookhold, J. L.
  1967. Report on data retrieval and analysis of USAF sonic boom claims files, SRI, TR-4, Contract AF49(638) - 1696.
14. Hartsough, G. R.
  1968. MUCH STILL TO BE DONE IN SONIC BOOM RESEARCH. *American Fur Breeder* 21.
15. Heinemann, J. M.
  1967. "Opinion of Staff Veterinarian, Environmental Health Laboratory," Kelly Air Force Base, Tex.
16. Heinemann, J. M.
  1969. Effects of sonic booms on the hatchability of chicken eggs, and other studies of aircraft-generated noise effects of animals. Paper presented at the Symposium on Extra-Auditory Effects of Audible Sound, Annual Meeting of AAAS, Boston, Mass., December 29, 1969.
17. Jensen, H.
  1962. Responsibility for damage to fur animals caused by shock from aeroplane engines. *Medlemsbl, danske dyrlaegeforen.* 45:787-788.
18. Jensen, M. M., and Rasmussen, A. F.
  1963. Stress and susceptibility to viral infection. I. Response of adrenals, liver, thymus, spleen and peripheral leucocyte counts to sound stress. *J. Immun.* 90:17-20.

19. Kryter, Karl D.
  1970. The effects of noise on man. Academic Press, New York. 634 pp.
20. Kull, K. E.
  1962. Damage due to panic on mink farms. *Vora Poolsdjur (Our Fur-Bearing Animals)* 34:107.
21. Leader, R. W., Padgett, G. A., and Gorham, J. R.
  1963. Studies of abnormal leukocyte bodies in the mink. *Blood* 22:477-484.
22. Loring, J. C. G.
  1953. Selected bibliography on the effects of high intensity noise on man. *J. Speech and Hearing Disorders. Monograph Supplement 3*, pp. 38.
23. Majeau-Chargois, D. A., Berlin, C. I., and Whitehouse, G. D.
  1970. Sonic boom effects on the organ of corti. *Laryngoscope. LXXX(4)*:620-630.
24. Morozov, B. H.
  1969. The biological action of impulse noises. A review of literature. *Voennomed. Zh.* 8:53-59.
25. Mossin, O.
  1962. Disturbances in whelping period as the result of shooting. *Norsk. Pelsdyrblad.* 36(8):127-129.
26. National Academy of Sciences, National Research Council.
  1970. An annotated bibliography on animal response to sonic booms and other loud sounds. A report of the Subcommittee on Animal Response Committee on SST-Sonic Boom.
27. Neher, G. M., Chairman.
  1970. The role of noise as a physiologic stressor. Publication No. FY 71-R1, 1970, HEW Environmental Health Service, Environmental Control Administration, Bureau of Community Environmental Mgn., Environ. Epidemiology Branch, Cincinnati Labs., Cincinnati, Ohio.

28. Nixon, C. W., Hille, H. K., Sommer, H. C. and Guild, E.  
1968. Sonic booms resulting from extremely low-altitude supersonic flight; measurements and observations on houses, livestock and people. Aerospace Med. Res. Lab. AFSC, Wright-Patterson Air Force Base. AMRL-TR-68-52. 22 pp.
29. Padgett, G. A., Leader, R. W., Gorham, J. R., and O'Mary. C. C.  
1964. The familial occurrence of the Chediak-Higashi syndrome in mink and cattle. Genetics 49(3):505-512.
30. Padgett, G. A., Reiquam, C. W., Gorham, J. R., Henson, J. B. and O'Mary C. C.  
1967. Comparative studies of the Chediak-Higashi syndrome. American Journal of Pathology 51(4):553-571.
31. Pallen, D.  
1944. Practical mink breeding methods. Fur Trade Journal of Canada, p.8.
32. Pernu, L. O.  
1968. Sonic boom echoes from Astoria, Oregon. Amer. Fur Breeder 41(9):11-26.
33. Robertson, W. B. Jr.  
1970. Mass Hatching Failure of Dry Tortugas Sooty Terns. 15th International Ornithological Congress, The Hague, Holland.
34. Sackler, A. M., Weltman, A. S., and Jurtshuk, P.  
1960. Endocrine aspects of intense auditory stress. Aerospace Med. 31:749-759.
35. Shackelford, R. M.  
1971. "Types of Mink" in Blue Book of Fur Farming. Communications Marketing, Inc., Edina, Minn.
36. Taylor, L. Z.  
1968. Sonic booms "common denominator" in Minnesota mink kit mortality. Amer. Fur Breeder 41(6):20-21.

37. Travis, H. F., Richardson, G. V., Menear, J. R., and Bond, J.  
1968. The effects of simulated sonic booms on reproduction and behavior of farm-raised mink. USDA, ARS 44-200. 18 pp.
38. U. S. Department of Agriculture, Crop Reporting Board S.R.S.  
1971. Mink production. 7 pp mimeo reporting mink production in U. S. in 1970.
39. Welch, B. L., and Welch, A. S. Editors.  
1970. Physiological effects of noise. Plenum Press, New York. 345 pp.

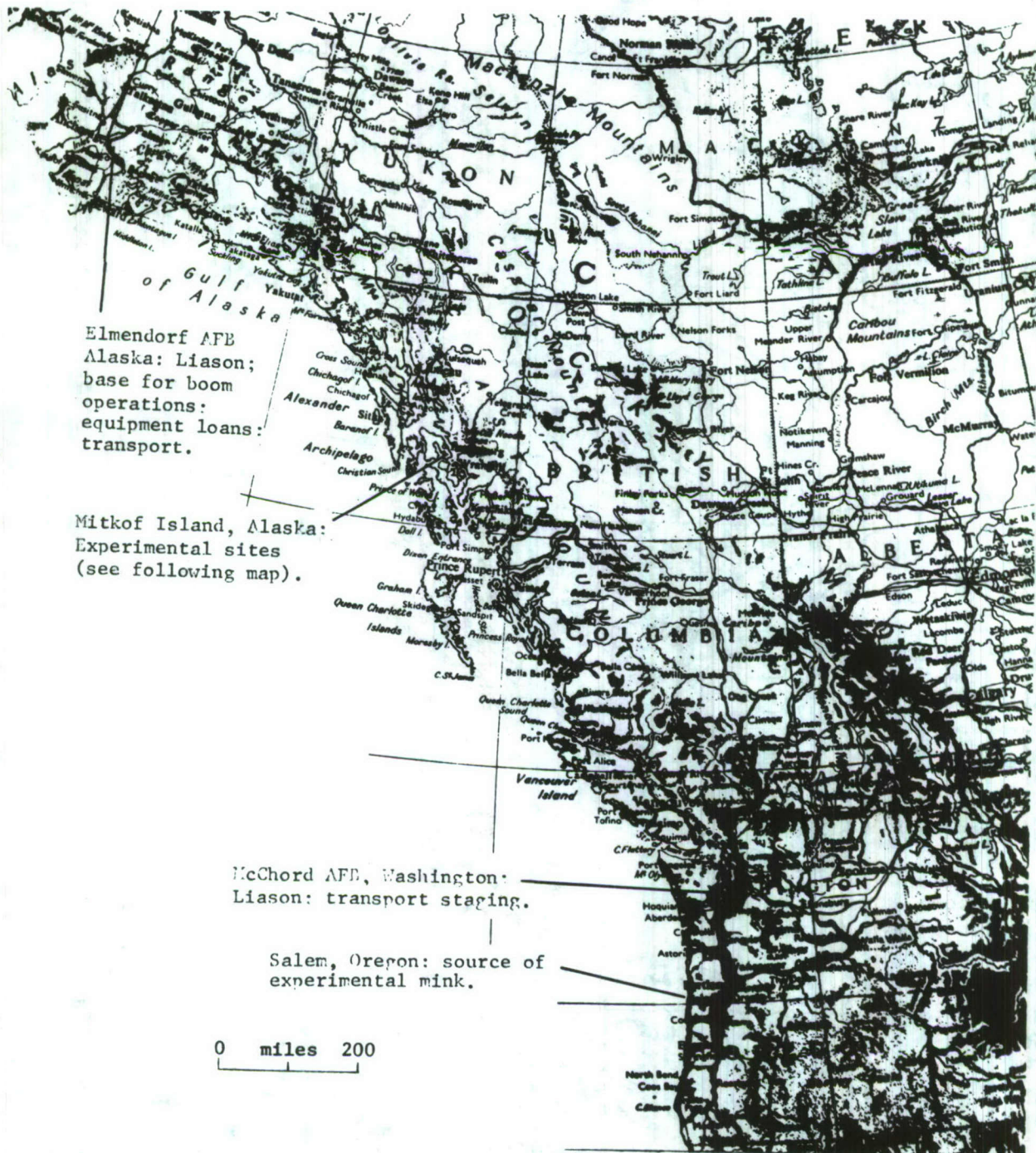

Figure 1.--Map of Northwest Pacific Ocean Coast locating operation sites.



Figure 2.--Map of Mitkof Island locating experiment sites. 1. Control Site; 2. Simulator Site; 3. Boom Site; and 4. Lateral Observer.



Figure 3.--Aerial photograph of control site.

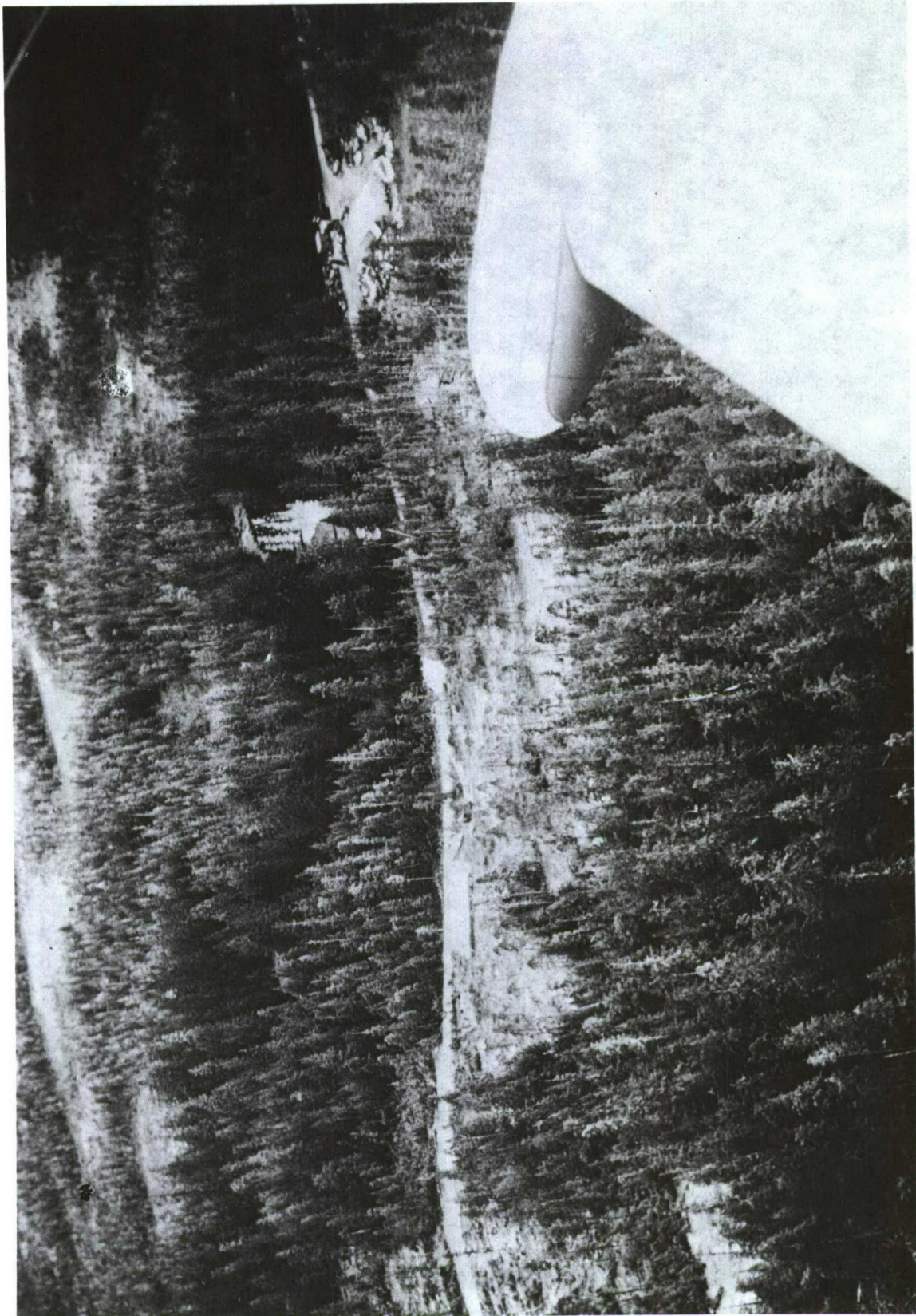

Figure 4.--Aerial photograph of simulator site.



Figure 5.--Aerial photograph of real boom site.

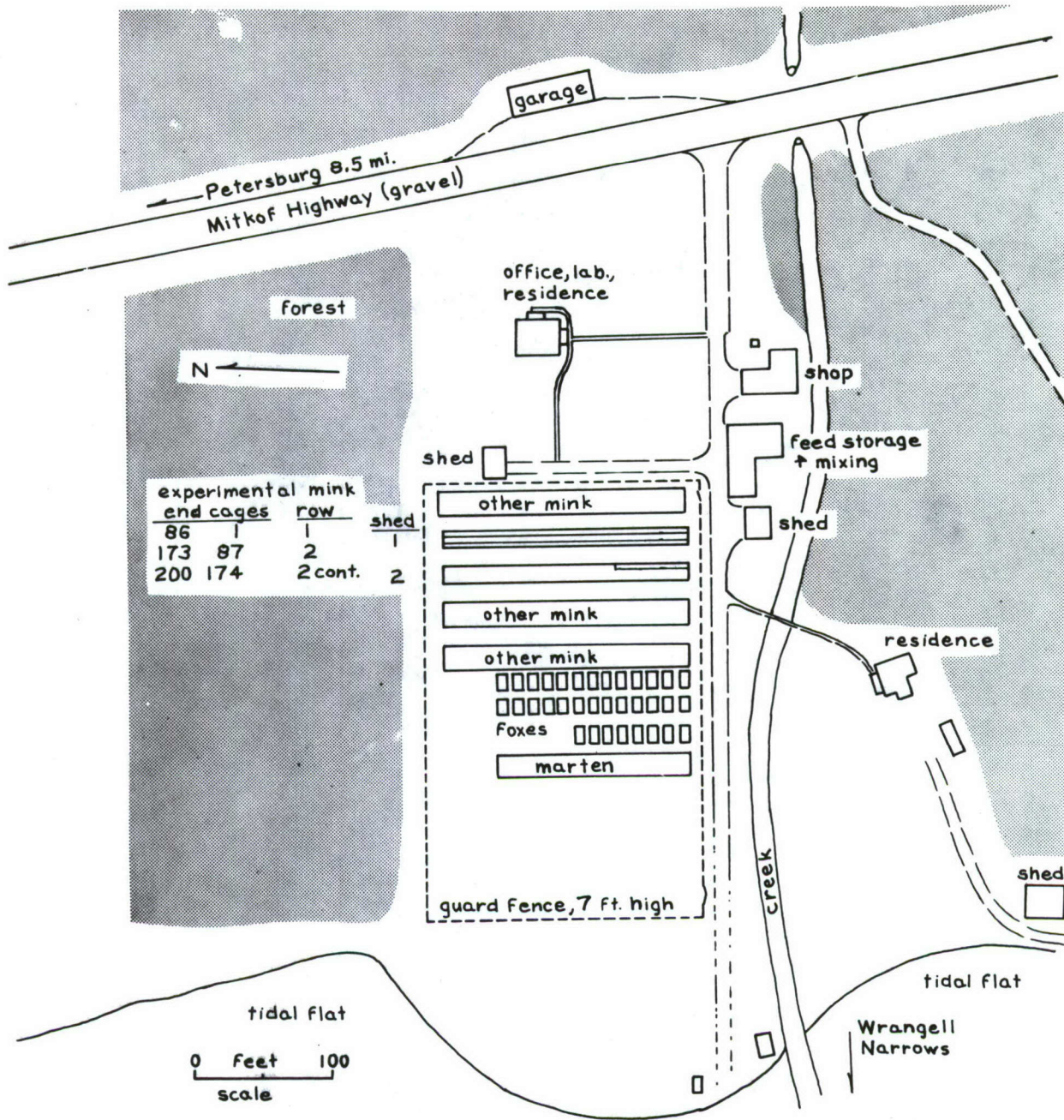

Figure 6.--Map of control site. University of Alaska Experimental Fur Farm, Petersburg, Mitkof Island.

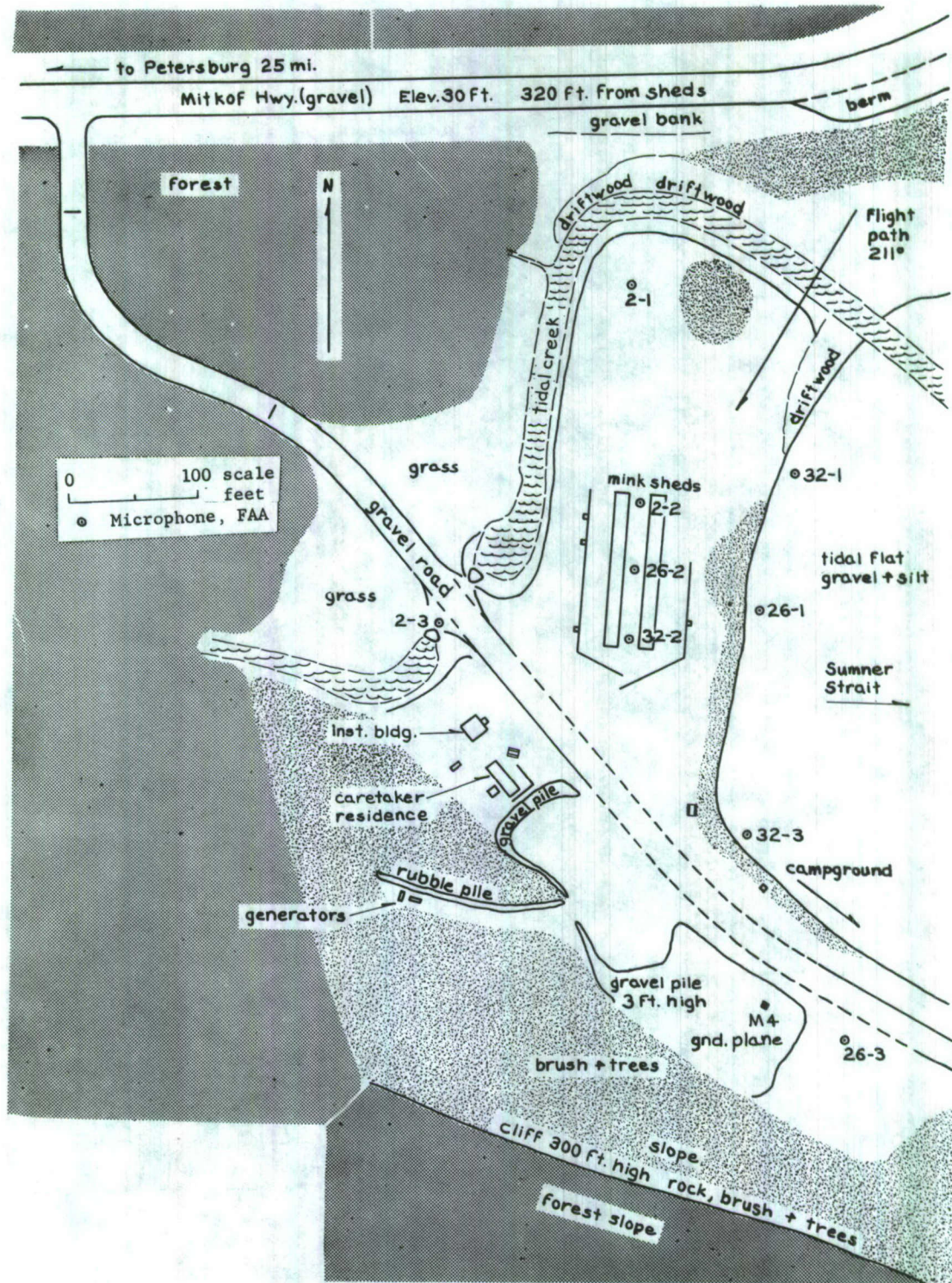

Figure 7.--Map of boom site Cool Mink 1970 Sumner Strait, Mitkof Island, Alaska,  $56^{\circ}32'30''N$ ,  $132^{\circ}40'30''W$ , Elevation 10 feet, surfaces not noted are level gravel and silt.



Figure 8.--Inside mink shed showing pens and nest boxes.

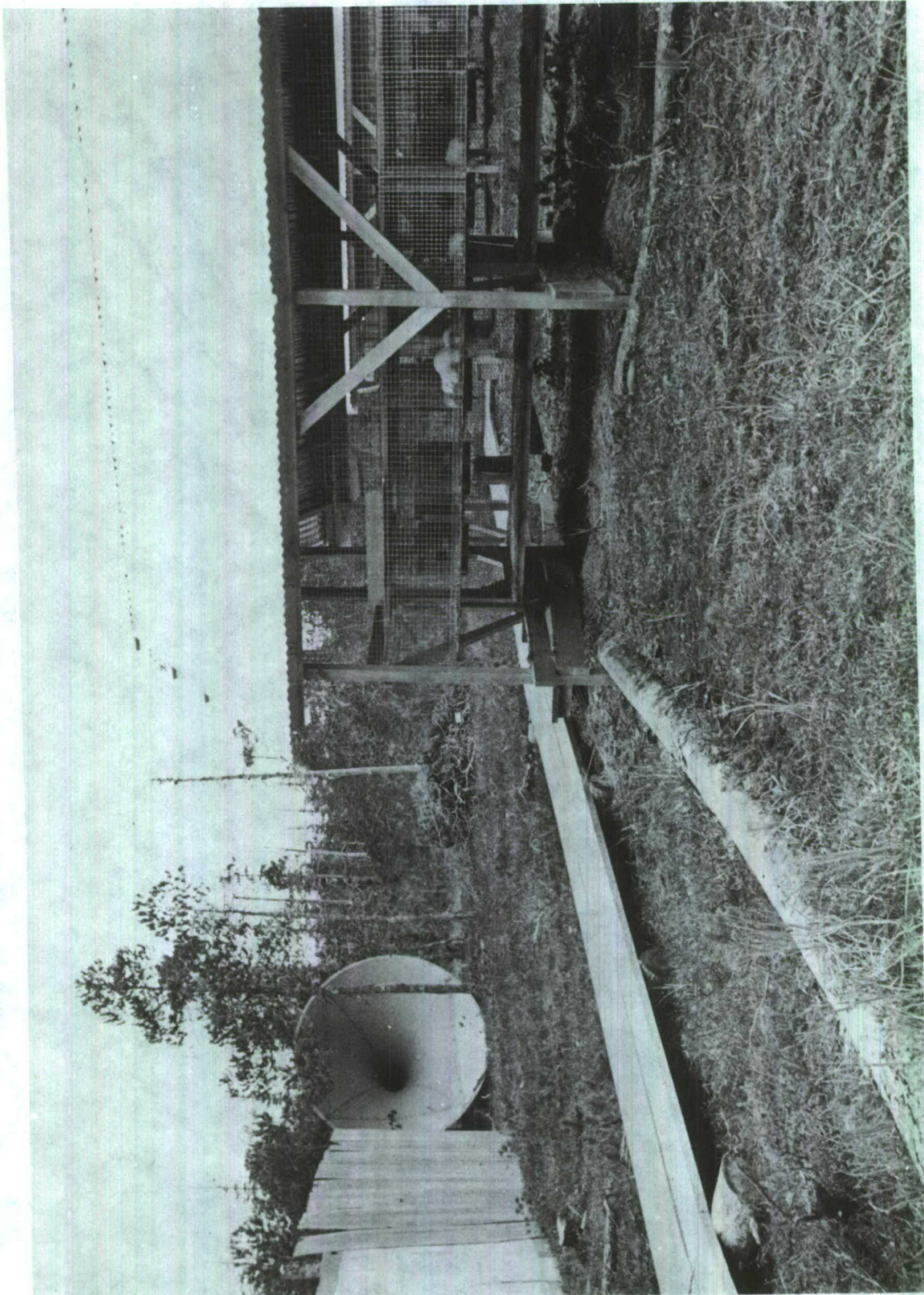

Figure 9.--Mink shed showing location of simulator.



Figure 10.--Photograph showing blind around real sonic boom site.

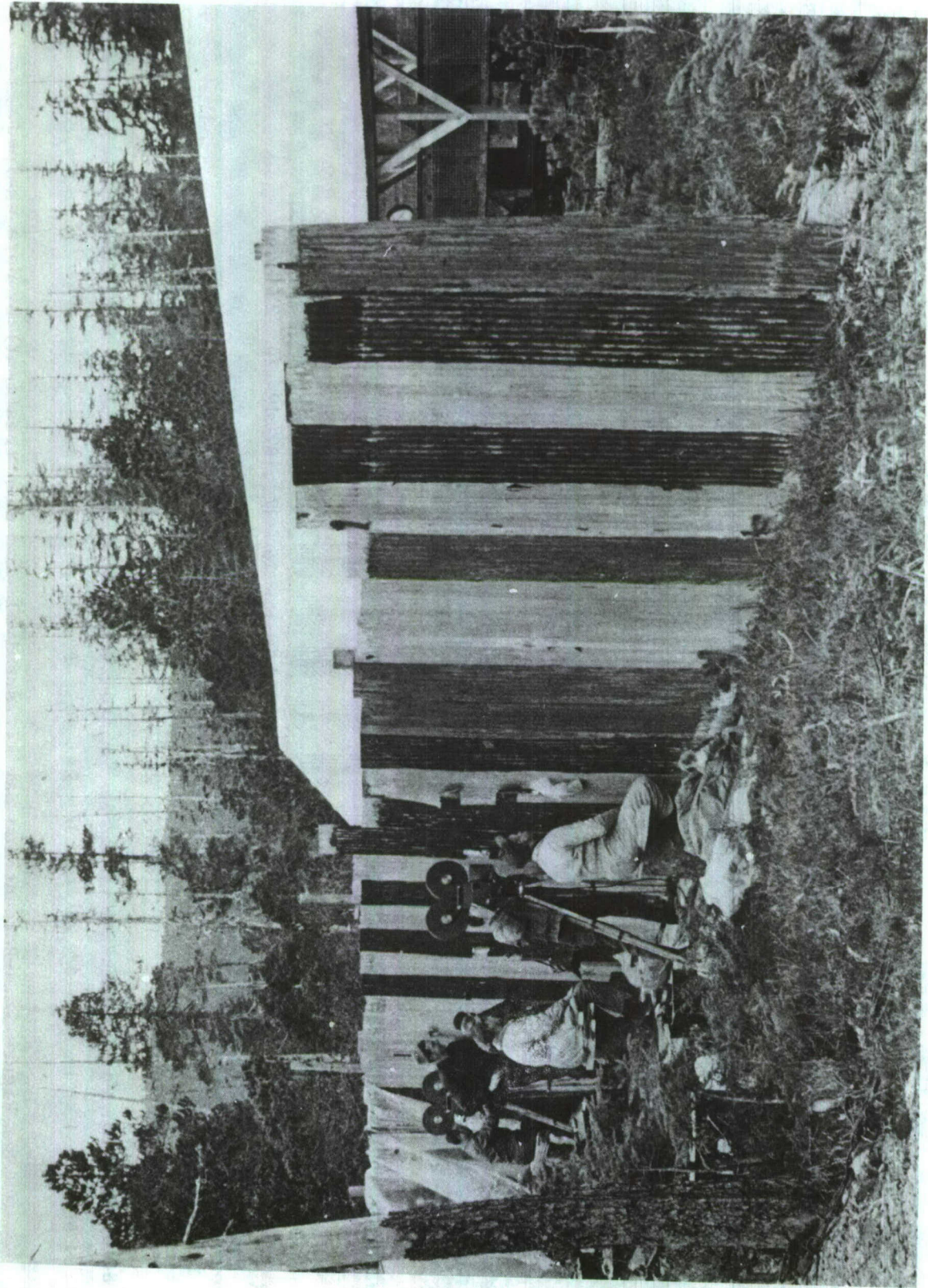

Figure 11.--Photograph showing blind at simulator site with observers and cameras in place.

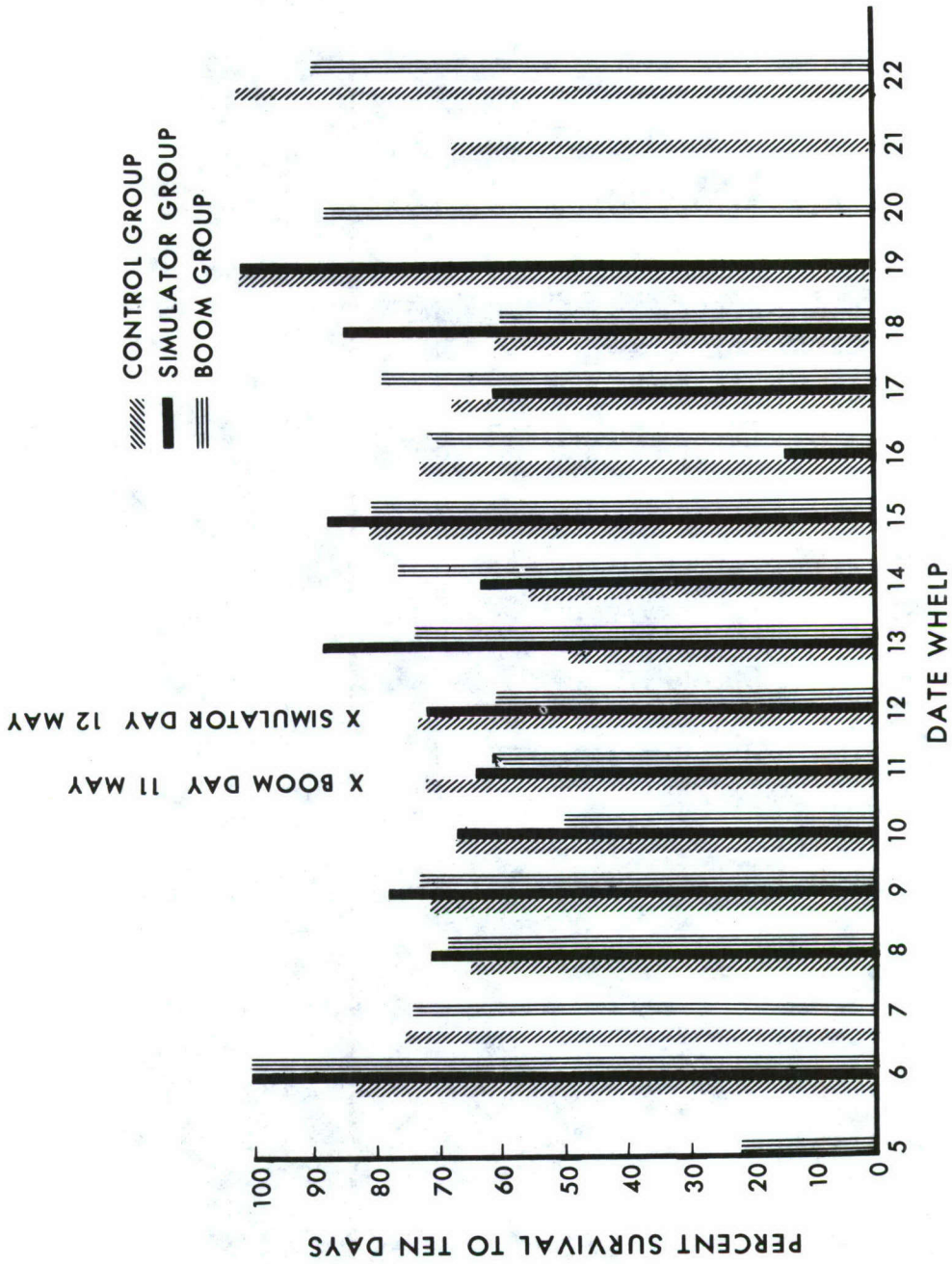

Figure 12.--Percent ten day kit survival (for each treatment) by date whelped.

## Physical Environment And Boom Effects

John R. Menear<sup>1/</sup>

### BOOM GENERATION

Flight conditions for a given airplane to produce booms of the needed overpressure were specified by the National Aeronautics and Space Administration, as shown in figure 1, plus data on the nominal waveform to be expected from ground plane recording. Although a variety of combinations of altitude and speed could have given the needed overpressure, selection was restricted by the need to minimize the boomed area. This resulted in an altitude less than that for which overpressure predictions were commonly available, and a speed less than that needed for assured stable flight. Specified flight conditions were a straight, level path with fixed altitude at 8,000 feet altitude and speed corresponding to a Mach Number of 1.2. It was essential that these conditions be held as constant as possible over the part of the flight path which was the source of the boom at the test site. Figure 2 shows the geometry of boom propagation for the specified conditions. The ground incidence angle shown was estimated from data recorded in these tests.

The U.S. Air Force generated three sonic booms, using an F4E airplane with full internal fuel and no external stores. Considerable planning and logistic operation were needed to assure timing and placement of the booms, spare boom airplane, air refueling, and communication with the site. Reconnaissance overflights, on the flight path at altitude specified for the booms but not at supersonic speed, were made at 1032 and 1039 on 11 May, boom day. For the boom overflights, radar beacons were placed at the site for guidance and ranging. Radio contact with the site was maintained at all times, and a running countdown of range was given from the airplane.

There was a possibility that local atmospheric conditions could affect the overpressure of the booms. To permit adjustment of later booms if the first or second differed greatly from prediction, a procedure was arranged to change the altitude of the airplane by an incremental amount calculated to yield the predicted overpressure on the next boom. This required an indication of measured overpressure within a few minutes of recording, and a report of actual altitude and speed from the airplane for the time when the part of the wave which struck the site was made. Corrected altitude for the next overflight would then be given to the airplane. In view of the known variability of measured overpressures, a deviation of at least

---

<sup>1/</sup> Agricultural Engineer, Agricultural Research Service, U.S. Department of Agriculture, Beltsville, Md. 20705.

20 percent from predicted overpressure was considered necessary to justify adjustment. Accordingly, no adjustments were made, and this proved to be the correct action. If adjustments had been made after the first or second booms, variation would have probably been more than it was.

To document propagation conditions, surface weather observations were made at the site by a qualified observer of the U.S. Air Force. A set of observations was made within 1 minute of each of the three booms. The weather was cool, partly cloudy, calm, and nearly constant: Temperature 54-55°F.; relative humidity 77 percent; barometric pressure 29.975-29.985 inches of mercury; wind 2 knots at 120-130°; total sky cover 80-100 percent, mainly an altocumulus layer at estimated 8,500 feet; slight haze, visibility 15 miles; the airplane was visible from the site on all three booming flights, and it reported no turbulence at 8,000 feet altitude.

### ESSENTIAL MEASUREMENTS

Sonic boom can be sensed by an animal in two possible ways; directly, by air pressure variation, or indirectly, through induced motion of surrounding objects. Air pressure variation is sensed as sound and, to some extent, as pressure impulse on the body surface generally. Induced motion is sensed as force variations on supporting body parts, as kinesthetic unbalance, and as visible or audible indications of motion of surrounding objects. For mink caged as in this study, a boom can be almost fully described, in objective physical terms, by continuous measurement over time of air pressure and structural motion, representative of the confinement spaces. Possible exceptions are visual phenomena associated with a boom.

There were two main reasons for measuring the sonic booms used here. First, to describe the pressure variations which were imposed on the site in definite terms comparable to those of other sonic booms. Second, to describe the pressure variations to which the animals were actually subjected, which, because of varying propagation, reflection and absorption conditions may be different from the definitive boom measurement. This required positioning of pressure sensors within the mink cages and nest boxes.

Probably the most definitive measurement of sonic boom pressure is that made on a ground plane; that is, by a sensor placed in the plane of a flat, smooth, horizontal surface which absorbs little of the wave energy. Necessary conditions include a wide, unobstructed propagation path from the source, and sufficient distance from projections to exclude spurious reflections from the measurement. Such a measurement essentially describes the free-field propagating pressure at the instant of contact, although it is twice the free-field pressure because of additive reflection.

Motion measurements representative of the structural parts supporting the mink were needed, either of the mesh floor of the cage or the nest box. Meaningful measurement at the cage floor was precluded because the mass of the sensors available would have considerably changed the dynamic characteristics of the floor. Therefore, the only practical measurement of motion directly affecting the mink was on the nest boxes. In addition to this essential motion measurement, another of interest in this study was that of the roof slopes. These were the only large flat surfaces on the sheds; their reaction to air pressure variation would cause nearly all other motions of the shed parts, aside from seismic effects.

#### APPARATUS

Sensor Location. Ground plane measurement was done with a microphone mounted in a ground plane board as shown in Figure 3. The board was 1/2-inch plywood, 4 feet square; the microphone was mounted flush in a ring of foam rubber 3/8-inch thick annularly. A loop of the signal wire was positioned directly above the microphone to support a rain cover, if needed during tests. To assure a wide, clear ray path, the board was located in an open area 300 feet from the sheds, as shown in the southeast corner of the boom site map in the first section of this report. About 150 feet along the flight path from this location was a nearly vertical cliff, at an angle of about 80°. Reflected waves from the cliff would arrive at the microphone about 0.2 seconds after the direct wave, and so could not interfere with waveform measurements. After the booms, none of the three ground plane recordings showed any recognizable N wave reflection at that time lag; however, the tail of disturbance following the N wave could have masked a weak reflection.

Measurement representative of the cages was done with two microphones located between cages as indicated in Figures 4 and 5 at a height of about 56 inches. To keep the microphones and cables out of reach of the mink, each was supported on a rubber band attached to a wire hook bridging between the cages as shown in Figure 5. The attached cable trailed to the ground, thus stretching the rubber band slightly and holding the microphone face up. Except for the shed structure, these microphones had clear ray paths; however, the path to the boomward side microphone passed close to the end of the east blind. The ground surface was level, settled, damp silt and gravel.

Pressure inside a nest box was measured by a microphone placed inside an unoccupied box on the boomward side as shown in Figure 5. The box was filled with bedding up to the bottom of the entrance hole, as were the occupied boxes and the microphone was laid on the bedding in the center of the box.

To measure structural motions affecting the mink, two nest boxes in the boomward shed were instrumented with triaxial assemblies of accelerometers, as shown in Figure 5. An assembly weighed about 1 pound, so did not greatly add to the 10-pound mass of an empty nest box. These assemblies sensed, relative to the shed orientation, longitudinal, transverse, and vertical accelerations of the inward wall of the nest box. Also, on each slope of the roof of the same shed, an accelerometer was mounted normal to the surface, to sense flexing in diaphragm mode. These were located midway in the width of the slopes, above the nest box accelerometer assemblies as shown in Figures 4 and 5 and would simultaneously sense a component of any transverse motion of the entire roof, if such occurred. Figure 6 shows accelerometer assemblies fitted with thumbscrew mountings for quick attachment, to facilitate moving between test sites.

Recording. The instrument system used by the principal investigators, here called the NASA system, was loaned by NASA-Langley Research Center, Hampton, Virginia. It measured and recorded 12 simultaneous inputs of air pressure variation and structural acceleration at shock wave rates. Operating capabilities included field calibration, simultaneous direct plotting on strip chart and recording on magnetic tape, and subsequent plotting of the taped record. A voice annotation channel was also provided on the magnetic tape. The system was a variation of one developed and used successfully in extensive sonic boom tests<sup>2/</sup>. Specific requirements for the present application were determined in consultation by USDA and NASA personnel; the USDA operator was given assistance, advice, and facilities throughout a 6-week period while assembling and testing the system. The 12 inputs, four air pressure and eight acceleration, were a minimum for adequate measurement and gave little redundancy. However, problems of availability, transport, and power supply ruled out a larger system; considerable effort was, therefore, put to assure reliability and spare parts for the 12 data channels. The direct plotting oscillographs were run at chart speeds of 40 inches per second and trace deviations of 1 inch at expected signal amplitudes. The tape machine was run at 30 inches per second in frequency modulated mode. A block diagram of the complete system is shown in Appendix I.

Sensors and Calibration. The air pressure sensors were stretched-diaphragm capacitance microphones of 1 inch nominal diameter, modified specially for sonic boom waveform measurement. Absolute calibration of the complete microphone channels was done with an infrasonic pistonphone, and the response to each microphone to low frequencies was determined at the same time. The pistonphone provided a sinusoidal variation of air pressure in a small chamber in which a microphone could be placed; frequencies from 0.05 to 10 Hz. (Hertz) were used. Also, a portable acoustic calibrator for field use was calibrated to the pistonphone.

---

<sup>2/</sup> Hilton, D.A., and Newman, J.W. Jr. 1966. Instrumentation Techniques For Measurement of Sonic-Boom Signatures. J. Acoustical Soc. Amer. 39(5):531.

The structural motion sensors were uniaxial, suspended mass, servo type accelerometers. Absolute calibration was done by gravity in both laboratory and field by holding them at various angles on a leveled calibration block, which also gave a check of linearity.

The overall frequency response of complete signal processing channels, exclusive of sensors, was checked by replacing the sensors with a "dummy microphone" excited by an audio sweep signal generator which produced a constant amplitude sine wave. With gain adjusted to drive the oscillograph to a level expected in the sonic boom recording, each channel varied less than 0.5 decibel between 20 and 11,000 Hz.

### BOOM WAVEFORMS

The direct-plotted oscillograph charts were measured to determine dimensions of the pressure-time waveforms. For each of the four microphone channels, an average of calibrations before and after the booms was used. Drift through the test interval was less than 2 percent in each case. Waveforms shown here were traced directly from the original charts; scale varied slightly between channels.

Measurement on ground plane. Waveforms of the three booms as measured on the ground plane, and the predicted nominal waveform, are shown in Figure 7. In general, the recorded waveforms are quite similar to each other and to the nominal. This similarity permits some discussion of group waveform characteristics even though the number of booms was small. The main difference between booms occurred within periods of about 10 milliseconds immediately following the rapid rises and including maximum overpressures. The main differences from nominal were also in these periods, and in the long tails of disturbance following the N waves.

Spikes on the waveforms appeared only as extensions of the rapid rises, and increased in height successively in the three booms; if flight conditions are assumed constant, this indicates some progressive change of propagation conditions over the time interval between booms. Boom one had no spikes, although there were pauses at the peaks of the rises indicative of the tendency. Boom two had rudimentary spikes, but following pressure quickly increased to a greater value, so that they were hardly a significant feature of the waveform. Boom three had spikes as high or higher than any following pressure, which did not begin to rise again until about 4 milliseconds after the spikes. Rise times of the rapid rises, with or without spikes, were all about 0.2 milliseconds, as scaled on the directly plotted oscillograph charts. This is somewhat less than commonly reported values, but is within the capability of the measuring system used here as evaluated by NASA for accurate recording of rapid rises. Maximum overpressures other than spikes occurred about 7 milliseconds after the rises.

In each boom a characteristic feature, detectable by human subjects, was the minor rapid rise of about 1.5 pounds per square foot, which occurred 26 to 29 milliseconds after the first rise. After this minor rise, pressure decreased nearly linearly with time to maximum negative overpressure, which deviated from ambient more than the positive maximum.

The second rapid rise of each boom, measured from the negative maximum as zero was greater than the first. Table 1 summarizes all boom overpressure measurements of the NASA system.

Measurements at Cages. The waveforms of boom one at the cage locations are shown in Figure 8, along with a replica of the ground plane waveform, and the nominal waveform composited for cage height. Cage waveforms for booms two and three are in Figure 9. The waveforms at the cages have several distinctive features; the most obvious is the interrupted rapid rises due to time lag between incident and reflected waves.

Compared to the ground-plane measurements, rise times of both incident and reflected parts of the booms measured at the cages were equal or greater in all cases, as listed in Table 2. If rise time of the ground-plane measurement is assumed equal to free-field incident rise time, the increase at the cages, in the incident rises at least, must be caused by disruption of the waves by the structures. This seems to be confirmed by the greater increase on the leeward side of the shed. However, on the boomward side, the only direct obstructions in the ray path to the microphone were a few wire meshes. Incident rise times increased as much or more than reflected rise times in 10 of 12 cases. This denies appreciable lengthening by reflection from the ground surface, and along with the preceding result, calls for explanation of lengthening of incident rises specifically within a few feet of the sheds. A possible cause was scattering reflections from structural surfaces close to the ray path to the microphone.

Measured lag between incident and reflected parts was about the same on the two sides of the shed, but the measurement on the boomward side was probably the best estimate of clear field lag. This value, averaging 3.6 milliseconds, corresponded to a ray incidence angle with the ground of  $26^\circ$ , somewhat greater than expected on the basis of some previous work<sup>3/</sup>. The difference can be attributed to the lower altitude of flights of the present test. Overall rise time on the leeward side was equal or slightly greater than that on the boomward side in all six rises.

In order of occurrence, the three booms as measured at the cages deviated progressively in waveform shape from nominal and from their

---

<sup>3/</sup> Maglieri, D.J., Parrott, T.L., Hilton, D.A. and Copeland, W.L. Lateral-Spread Sonic-Boom Ground-Pressure Measurements from Airplanes at Altitudes to 75,000 Feet and at Mach Numbers to 2.0. NASA TN D-2021, November 1963.

TABLE 1.--Boom overpressures in pounds per square foot and rise ratio: combined/incident

Boom	Rise	Measurement location											
		Gnd. plane		Boomward cages			Leeward cages			Nest box			
		Comb- rise	Max. devi- ation	Rise Comb- ined	Max. Inci- dent	devi- ation	Rat- io	Rise Comb- ined	Max. Inci- dent	devi- ation	io	First peak	Max. dev.-
1	1	6.36	7.55	6.55	3.46	6.67	1.90	6.35	3.71	6.79	1.71	5.48	10.5
	2	7.10	-7.67	7.15	3.79	-8.30	1.89	6.35	3.74	-7.07	1.73	6.20	-8.04
2	1	5.44	6.30	4.97	2.91	4.87	1.70	5.35	3.09	6.06	1.73	4.35	7.80
	2	6.30	-7.11	5.27	3.15	-7.10	1.73	5.35	3.09	-6.95	1.73	4.45	-7.20
3	1	6.68	6.68	3.64	1.91	4.57	1.91	3.74	1.90	4.99	1.97	2.80	5.48
	2	6.92	-6.18	3.64	1.82	-6.55	1.98	3.15	1.73	-5.82	1.78	2.44	-6.09
Avg	1	6.16	6.84	5.05	2.76	5.37	1.84	5.15	2.90	5.95	1.80	4.21	7.93
	2	6.77	-6.99	5.35	2.92	-7.32	1.87	4.95	2.85	-6.61	1.75	4.36	-7.11
	Avg	6.45	-	5.20	2.84	-	1.85	5.05	2.88	-	1.77	4.29	-

TABLE 2.--Times and rates of rapid rise of booms; in milliseconds to peak or start of rounding, and pounds per square foot per millisecond, respectively.

Boom	Rise	Measurement location								
		Gnd. Plane	Boom side cages				Lee side cages			
			Inci- dent	Lag	refl- ected	Comb- ined	Inci- dent	Lag	Refl- ected	Comb- ined
<u>Rise time</u>										
1	1	0.2	0.5	3.7	0.3	4.0	1.0	3.5	1.0	4.5
	2	0.2	1.0	3.5	1.0	4.5	1.5	3.5	1.0	4.5
2	1	0.2	0.5	3.5	1.0	4.5	1.5	3.5	1.0	4.5
	2	0.2	0.3	3.5	1.0	4.5	1.5	3.8	0.7	4.5
3	1	0.2	0.3	3.8	0.2	4.0	1.4	3.5	0.8	4.3
	2	<u>0.2</u>	<u>0.3</u>	<u>3.7</u>	<u>0.3</u>	<u>4.0</u>	<u>1.4</u>	<u>3.3</u>	<u>0.9</u>	<u>4.2</u>
Avg	1	0.2	0.4	3.7	0.5	4.2	1.3	3.5	0.9	4.4
	2	0.2	0.5	3.6	0.8	4.3	1.5	3.5	0.9	4.4
	Avg	<u>0.2</u>	<u>0.5</u>	<u>3.6</u>	<u>0.6</u>	<u>4.2</u>	<u>1.4</u>	<u>3.5</u>	<u>0.9</u>	<u>4.4</u>
<u>Rise rate</u>										
1	1	31.8	6.9		12.7	1.6	3.7		3.0	1.4
	2	35.0	3.8		4.0	1.6	2.5		3.0	1.4
2	1	27.2	5.8		2.6	1.1	2.1		2.5	1.2
	2	31.5	10.5		1.5	1.2	1.9		2.6	1.2
3	1	33.4	6.4		9.5	0.9	1.4		2.4	0.9
	2	<u>34.6</u>	<u>6.1</u>		<u>6.7</u>	<u>0.9</u>	<u>1.2</u>		<u>1.8</u>	<u>0.8</u>
Avg	1	30.8	6.4		8.3	1.2	2.4		2.6	1.2
	2	34.0	6.8		4.1	1.2	1.9		2.5	1.1
	Avg	<u>32.8</u>	<u>6.6</u>		<u>6.1</u>	<u>1.2</u>	<u>2.1</u>		<u>2.6</u>	<u>1.2</u>

respective ground-plane waveforms; this coincided with the similarly progressive decrease in rapid rise overpressure. Boom one retained a definite N wave shape at the cages and was not very different from the ground plane waveform. Booms two and three show increasing rounding of the waveforms following the rapid rises. In boom three it was so pronounced that the rapid rises were little more than minor disturbances in a rounded waveform. Maximum negative overpressure was nearly as great as on the ground plane, but the second rapid rise accounted for little more than half of the return to ambient. No rapid rise spikes were detected in the cage waveforms; rather, appearance of spikes on the ground plane coincided with greater rounding at the cages. Minor disturbance imposed on the waveform was greater at the cages than on the ground plane for all booms, but successive booms had less. The tendency to similarity of waveform features following first and second rises was strong at the cages.

Because of the lengthened combined rise times at cage heights, combined rise rate there was greatly reduced relative to the ground plane. This suggests that, in a zone close to the ground, the intensity of any effect which depended on rise rate would decrease with height above ground. Measurements taken a few feet above ground, or subjective evaluation by a standing person, may underestimate such effects closer to the ground. Table 2 includes approximate rise rates calculated for the three booms; precise values would require machine transcribing of taped data, which was not done here.

Included in Table 1, for the cage waveforms, are ratios of pressures of combined rise to incident rise, which is an estimate of the reflection coefficient of the earth surface at the site. The average value on the boomward side, which is probably the best estimate within these data, is 1.85, close to the 1.9 predicted value. However, the considerable variation of ratios between booms indicates some unaccounted factor of reflection, or measurement error, or both; these data were not primarily intended for calculation of the ratio.

Measurement in nest box. Also shown in Figures 8 and 9 are waveforms measured inside a nest box on the boomward side. The general characteristic of these was a damped oscillation imposed on the corresponding waveform measured at the cages. There was a tendency to sinusoidal form at a stable frequency of 230 Hz. with the rapid rises modified and included. Considered as a tone on the cage waveform, the oscillations had maximum amplitude equal to their first peaks, which are slightly less than the rapid rises in the cage waveforms. The second peaks, with about twice the deviation from ambient as the first, had slightly less amplitude than the first when based on the cage waveform. This tone was an effect of the box itself, since it did not appear in the cage waveforms. The combined overpressure of tone and N wave caused peak overpressures in the nest box considerably greater than those measured outside; rise times and rise rates inside the nest box were essentially those of the tone,

rather than of the N wave. The tone persisted, with diminishing amplitude, for about 10 cycles after each rapid rise.

Roadbuilding blast. After the three booms, the instrument systems remained in operation to measure the disturbance caused by an explosive blast 1 hour and 25 minutes later. This event was made part of the test because it was not practical to prevent it entirely; the blasting was done to loosen rock on a logging road about 8000 feet northeast of the site, at 400 feet altitude on a steep slope. This slope was close to the flight track, but faced southeast, perpendicular to it. Several drill holes charged with blasting powder were detonated simultaneously; details are unknown and of doubtful interest, considering the variability of possible shock effects. According to the blasting operator, this blast made a louder sound than typical in that operation, because of particular rock conditions.

The blast caused overpressures about one-tenth that of the booms, as measured at the site by the NASA system. The ground plane waveform of the blast is included in Figure 7; it was near sinusoidal, with a period about equal to that of the booms. There was no indication of a shock wave type of rapid rise. The microphones at cages and nest box gave very similar waveforms to the ground plane. However, another microphone system, operated simultaneously by personnel of the Federal Aviation Administration, indicated considerably larger overpressure from the blast, about half those of the booms. This system, and a summary of measurement results, is discussed in a later paragraph.

#### SIMULATED BOOMS

Apparatus, propagation, waveforms. Simulated booms were made by a special device that had been used in a previous test with mink<sup>4/</sup>. As shown in Figures 10 and 11, this sonic boom simulator consisted of a large exponential horn, 13.5 feet in diameter; into its small end, two charges of compressed inert gas could be released suddenly by rupture of thin diaphragms. Each charge produced a pressure pulse that was propagated from the horn as a coherent wavefront normal to and moving on the horn axis. Overpressure was mainly determined by the pressure of the driving gas and position relative to the horn. The effective overpressure field of the simulator was small; both rise rate and peak pressure declined with distance from the horn, and the decline was proportionally greater at higher overpressures. It was not possible to impose a uniform pressure disturbance on an area as large as the confinement space used in this study. The pulses were timed to an interval approximating the duration of the real booms.

Weather observations were made for the simulated booms identically to those for real booms; conditions were nearly identical. The simulated

---

<sup>4/</sup> Travis, H.F., Richardson, G.V., Menear, J.R., and Bond, J. The Effects of Simulated Sonic Booms on Reproduction and Behavior of Farm-Raised Min. USDA-ARS 44-200, June 1968.

booms, being very local phenomena, were hardly affected by weather conditions.

The simulator was positioned as in Figure 12, oriented at a small angle to the sheds as was the flight path at the real boom site, and with the horn axis centered in the confinement area. The nearest cage was 50 feet from the horn, and the most distant, 117 feet. On the basis of clear-field tests of simulator output, previously done at another location and shown in Figure 13(a), this was expected to produce overpressures averaging 6 psf in the confinement area. Measured pressures, Figure 13(b), were considerably less; the assumption that clear-field conditions were approximated at the simulator site was erroneous. There are three possible causes of the difference: scattering by the diagonal blind near the horn; the rough ground surface of spongy muskeg, an effective absorber of acoustic energy; or scattering by the shed structures, which could cause a greater gradient within the confinement area but would not affect pressures measured at the ends of the sheds nearest the horn. Because the simulated boom wave front was of limited lateral extent, rather than essentially unlimited as is that of a real boom, it would be scattered to a greater extent by any obstacles in the propagation path.

After simulated boom one, the overpressure deficiency was noted, and driver gas pressure was increased in an attempt to reach 6 pounds per square foot average overpressure. This caused a simulator failure: one diaphragm ruptured prematurely. The result was a single pulse, recorded by the FAA automatic system but not by the NASA system; it was counted as simulated boom two. For simulated boom three, driving gas pressure was the same as for the simulated boom one.

Simulated boom one subjected the mink nearest the horn to overpressure of about 5.8 pounds per square foot; those most distant, 1.6 pounds per square foot. The average for the entire group of mink was 3.5 pounds per square foot. In comparing the simulated boom overpressures to those of the real booms, the differences in propagation and measuring procedure should be considered. No ground-plane measurement was made of the simulated booms; previous work had verified that the waves moved parallel to the ground and no additive reflection occurred there. The simulated boom overpressures measured at the cages can be compared to real boom overpressures there, not to the ground-plane measurement. Furthermore, the simulated boom measurements represented wholly incident waves, not the sum of incident and ground-reflected waves. The relevance of this is that the simulated booms had continuous rapid rises, while the real boom rises were interrupted by the reflection time interval, which reduced their combined rise rates. If rise rate, within the range found here was an appreciable factor in the intensity of boom effects, the simulated booms were of somewhat greater intensity relative to real booms than indicated by peak overpressure alone. On the other hand, the rise rates of the simulated booms were themselves reduced with distance from the horn, so the most distant mink were subject to definitely lower rise rates, as well as lower overpressures.

Microphones to measure the simulated booms were located in the sheds at cage height as in Figure 12. Waveforms are shown in Figure 14, in real time relationship from the four microphones as they were successively engulfed by the shock waves. Each waveform consists of two very similar pulses, the second of slightly less overpressure. Each pulse consisted of a rapid rise spike with rise time of about 0.4 millisecond, followed by a nearly sinusoidal oscillation about ambient. The spikes diminished with distance from the horn more than did the oscillations, so that at the far end of the sheds, the spikes were less than the oscillation peaks. The oscillations were of constant 66 Hz. frequency and lasted about three cycles to extinction. Small oscillations of a few hundred Hz. and variable were also present.

The simulated booms closely replicated the rapid rises of real booms, and the timing between rises, but pressure variation in the interval was not the same. Although the oscillations in the simulated booms were larger than those in real booms, their rate of pressure change was considerably less than that of the rapid rises and would contribute little to effects dependent on rapid rise. A deficiency of the simulator, more severe at greater overpressures, was that the pulses consist essentially of sharp spikes of about 1 millisecond duration. The available pressure impulse was much less than that of real booms. Structural effects depend on impulse; the direct effect of impulse difference on mink is not known.

#### FAA BOOM MEASUREMENT

In addition to the NASA system used by the principal investigators, another completely independent system for measuring air pressure variations was installed and operated by personnel of the Federal Aviation Administration. The system consisted of three transient data recorders (TDR-5), each recording simultaneously from three microphones on magnetic tape. The microphones were ceramic piezoelectric hydrophones, with exposed cylindrical active elements about 4 inches long and 2 inches diameter, with hemispherical tops. They were mounted vertically on short pedestals attached to heavy concrete bases, which were buried to ground level. All of the microphones were placed at 1-foot height, and wind screens of mesh fabric on wire frames were placed over them. This system provided nine measurements (six at the simulator site) of each boom, with locations selected to cover the shed area and a considerable margin, and permitted an evaluation of the uniformity of the shock waves over lateral distance. Microphone locations at the boom site are shown on the map in the first section of this report, those at the simulator site, in Figure 12.

The FAA microphone location most directly comparable to the ground-plane measurement was 26-3, placed about 70 feet laterally

from the ground plane microphone on a gravel slope of about 0.07 upward along the flight track. Both locations had a clear ray path from the airplane.

Although the FAA microphones were covered with wind screens and NASA microphones were not, this would not affect recorded pressures. Trials with the NASA microphones using the sonic boom simulator showed that they could be enclosed in plastic bags without affecting measurements. During the booms, no ambient wind pressure was evident on any microphone recordings.

Detailed comparison between measurements by the two systems is impeded by the microphone mounting heights. All of the FAA microphones were at 1-foot height, which, at a ray incidence angle of  $26^\circ$  would cause the reflection from ground to lag the incident wave about 0.8 millisecond. Rise times were 0.2 millisecond on the ground plane so the FAA microphones would be expected to have recorded interrupted rises with overall rise times of about 1.0 millisecond. This would not have greatly affected maximum overpressure indications other than spikes which, if present in the ground-plane measurement, would probably be greatly reduced or absent. Table 3 gives overpressure data from the FAA system for booms, simulated booms, and the road-building blast.

#### AMBIENT NOISE

Typical ambient noise recorded at the boom site was representative of all three sites with respect to motor vehicle traffic, the main source of noise. The boom site and the control site were about the same distance from the Mitkof Highway and the simulator site was a similar distance from a repair station for logging vehicles. Heavy vehicle passage thus occurred frequently near each of the sites and was not greatly different between them. Aircraft and miscellaneous noise sources such as chainsaws were unscheduled, more or less random occurrences near all sites. Some background noise was present more or less continuously, due to wind and water movement, birds, animals, and distant human activity.

The noise data were recorded on magnetic tape by a U.S. Air Force observer, and analyzed by FAA. Table 4 presents sound pressure levels for several typical noises in terms of four broad-band spectral response weightings and an octave-band spectral analysis covering the human audible range. In absence of information on the spectral sensitivity of man, the noise levels can only be interpreted with respect to human response, which is what the weightings are intended to quantify for different spectral distributions. Because the several noises and the background noise were all mainly that of engine exhaust, their spectral distributions are similar and therefore are comparable by the levels given by any one weighting. This is confirmed by the similarity of trends in each weighting over the several noises. In general, the

TABLE 3.--Overpressures of booms, blast, and simulated booms measured by FAA system

Boom	Time, hour minute second	Micro- phone	Max. overpressure		Sim. boom	Time, hour minute second	Micro- phone	Max. overpressure							
			Positive	Negative				Positive	Negative						
1	105748	2-1	4.96	3.75	1	111010	2-1	0.95	0.94						
			2	4.94				4.90	2	1.64	1.32				
			3	5.59				5.13	3	2.28	2.03				
		26-1	5.51	4.48			32-1	0.70	0.97						
			2	5.23				5.14	2	1.66	1.83				
			3	6.70				4.72	3	0.78	0.63				
		32-1	6.48	5.30			2	115424	2-1	0.99	0.97				
			2	5.61						6.12	2	1.78	1.38		
			3	6.15						4.95	3	2.30	2.35		
		2	114418	2-1			4.38	4.18	3	121046	2-1	0.92	0.90		
							2	5.00				3.88	2	1.56	1.40
							3	5.48				3.71	3	2.25	1.96
26-1	3.60			4.89	32-1	0.56	0.60								
	2			4.05		4.59	2	1.82			1.59				
	3			5.31		4.49	3	0.67			0.58				
32-1	4.82			4.87	2	115955	2-1	3.14			3.30				
	2			4.69				4.88			2	3.18	3.83		
	3			4.44				4.76			3	3.89	4.16		
3	115955			26-1	3.67	3.21	Blast	132215			2-1	3.04	2.57		
					2	3.44						4.04	2	3.20	3.08
					3	5.06						4.34	3	3.23	3.20
		32-1	4.15	4.50	2	115955			26-1	3.67	3.21				
			2	3.17						4.10	2	3.44	4.04		
			3	3.47						4.11	3	5.06	4.34		

TABLE 4.—Ambient noise measurement at boom site, Mitkof Island, Alaska, 14 July 1970

Noise	Sound pressure level, Decibels re 0.2 nanobar												
	Broadband			Octave band midfrequency									
	Spectral response weighting			Direct									
	A	B	C	31.5	63	125	250	500	1000	2000	4000	8000	16,000
1. Background noise	44	48	52	54	44	52	44	40	38	38	35	26	24
2. Road grader	52	55	59	60	46	54	50	46	46	46	40	32	28
3. Logging truck	72	74	74	75	44	56	67	67	70	68	62	55	37
4. "	70	72	74	75	48	60	71	71	65	63	55	52	40
5. "	67	70	71	72	55	56	70	67	65	60	59	50	36
6. "	62	66	67	68	50	51	66	62	58	55	54	45	-
7. Pickup truck	68	73	74	76	55	67	70	71	68	66	60	54	41
8. Airplane, 2 eng.	53	62	68	72	44	54	72	62	55	51	45	44	34
9. Chain saw	60	64	70	71	57	62	60	60	58	49	46	37	-

noises produced continuous noise levels throughout the middle part of the audible range and decreasing levels at the extremes; a broad-land basis is therefore adequate to estimate loudness from these data.

The recorded noises range up to 28 decibels above background noise, or a factor of 25 in sound pressure. In terms of the sone loudness scale, which is intended to represent relative intensity of loudness sensations evaluated by humans, a factor of 5 was estimated from these data. Human observers at the site tended to evaluate the noises as quite loud compared to background noise. The response of the mink auditory system and associated physiological responses to these changes in sound pressure levels are not known.

### STRUCTURAL MOTIONS

Test Structures. The sheds were partly enclosed by blinds placed about 20 feet away, to shield the mink from possible disturbances by observing personnel. The blinds consisted of sheets of corrugated steel roofing, 0.022 inch thick and 8 feet long, nailed vertically on a frame of poles and miscellaneous lumber. At the boom site, exposed to seacoast weather, where the blinds also served as a windbreak, the poles were guyed with steel wire to anchors at ground level. Peepholes were cut in the blinds for observers as well as cine and television cameras.

The sheds were of an economical post construction with common nailed joints, as shown in Figure 5. There was no weather enclosure other than the roofs and the blinds as shown in Figure 4. Winds up to 40 knots caused no damage, with the blinds in place.

The cages, detailed in Figure 15, were made of welded wire mesh in partial assemblies of four fastened together with hog rings as in Figure 16. Assemblies were installed in the sheds by attachment with hog rings to the floor and to escape-proofing meshes which had been nailed to posts and support blocks. Nest boxes were simply hung by two nails on the mesh fronts of the cages. The supporting structure can be considered to be both elastic and loose-jointed. Although resistant to vibrational damage, it could transmit full or possibly amplified vibrations to the confinement spaces. The mechanism of structural effects is discussed in Appendix 2.

The main concern with structural motions in this study was to determine and measure those to which the mink were subject. The cages would directly share the horizontal motions of structural racking, and they also would be moved vertically by varying tension in the wires of the supporting escape-proofing mesh. The nest boxes would also share those motions, up to some low value of acceleration, beyond which they would chatter on their supports. The nest boxes were of main interest because whelping mink spend most of the time in them.

The main impulse causing structural deflection would be on the boomward slope of the roof, which was the only large surface exposed to the approach direction. This would cause diaphragm deflection of parts of that slope by bending of purlins and rafters, and also transverse racking of the cross section of the entire structure. Vibration would be likely in the same modes. The roof slope, with most of its mass in stiffening members and restrained by braces between the roof slopes, would tend to vibrate rapidly with small deflection. Racking vibration of the entire structure would tend to be relatively slow because much of the mass was high in the roof, and posts were few. Because the structure was relatively long, different rates of motion could occur along the length, thus causing longitudinal and plan racking. The resulting total motion of the shed would be complex, but mostly confined to the horizontal plane.

With the shed roofs at an average height of about 10 feet, the interruptions in the rapid rises of the composite wave there were about 8 milliseconds. That is, at the wave speed of 1320 feet per second, the ground-reflected rises lagged the incident rises about 20 feet horizontally. The entire composite N wave, about 135 feet long, passed in about 102 milliseconds. The sheds were oriented at a rather small angle,  $26^\circ$ , to the wave approach direction, in which their projected length was 112 feet, or nearly the length of the wave. As the first rapid rise reached the leeward end of a shed, the region of maximum negative pressure was engulfing the boomward end. At that instant, overpressure along the length of the shed varied from peak positive, through zero, to nearly peak negative. Net pressure on the roof, however, was probably equalized to zero within a few feet of the rise by equalizing flow under the eave. The impulse due to the first rapid rise would be completing traverse of the length at about the time the second impulse started on the boomward end. The boomward slopes of the roofs were, therefore, swept by two short positive pressure impulses with an interval of 94 milliseconds. At the boomward end, there was little interaction with other structures, but there was possibly an end effect due to exposure of the underside of the leeward roof slope. At the leeward end, shielding and reflection interactions of unknown magnitude between the two sheds and the blinds can reasonably be assumed.

Accelerometer data. The amplitude of vibrations to be caused by the booms was unknown beforehand, but the structures were lightly built and highly exposed, so considerably more than the small vibrations measured in tests with urban structures was expected. Some stages of the instrumentation had to be preset for operating range, thus limiting the magnitude of data which could be recorded. Fortunately, the accelerometer amplifiers developed by NASA were equipped with multiple-range switches requiring no other adjustment when switched. This somewhat relieved the need for close previous estimation of vibration amplitude. By observing the direct-plot oscillograph record immediately after the first boom, it was possible to determine a more suitable range and switch the amplifiers.

The data consisted of accelerometer oscillations lasting up to several seconds. With six events recorded plus calibrations, eight channels each, machine transcribing of the data was needed to produce plots suitable for analysis. The NASA instrument system had the capability, but the press of time for logistic operations after the tests precluded use of it. Transcribing was done later, in an arrangement with the Armed Forces Radiological Research Institute, Bethesda, Maryland, which had the rather uncommon instrumentation needed. Strip chart records of the eight channels were made at real time chart speeds of both 3.15 and 31.5 inches per second. No review of vibration phenomena in mathematical terms is included here, since it would be of little interest to the general reader. However, the following discussion includes several statements of physical relationships needed for interpreting the data.

The next four figures show vibration data as acceleration-time plots of eight accelerometers caused by a boom, a simulated boom, and a roadbuilding blast. The boom waveform in each figure has been drawn to approximate that which occurred at median roof height. A value of acceleration can be thought of as the magnitude of force applied to an object tending to move it. In general, when an object vibrates due to the elasticity of its supports, the direction of displacement from neutral position at any instant is opposite to the direction of acceleration shown on the plots. An important exception to this is during the application of the original exciting force - here, the rapid pressure rises of the boom. In this case, displacement is in the same direction as the acceleration.

These acceleration plots can be used as a rough indicator of vibratory motion, bearing in mind that large accelerations do not necessarily indicate large motions; displacement is proportional to time squared as well as to acceleration. If the time is very short, displacement may be imperceptibly small, to both animal senses and artificial displacement sensors. Despite large accelerations the most rapid vibration shown on the plots caused very slight motions. This is not to say that prolonged subjection to such vibrations would not cause an effect on animals or structures, but only that a few cycles of such vibration is not likely to cause an effect. A related consideration in this experiment is that the mink were to some degree isolated from the vibration of the nest boxes by the bedding on which they rested. The slower vibrations that appear on the plots had accelerations of lesser magnitude but were maintained over several milliseconds. Consequently, displacements were much larger than those caused by the rapid vibrations. Accelerations noted here were scaled from the plots to the nearest 0.1 g. (acceleration of gravity). Frequencies were estimated by counting peaks in a time interval as long as each frequency persisted continuously. Displacements from neutral were calculated by graphic integration of the acceleration plots. The sense of longitudinal and transverse directions is indicated as North, South, East or West.

Boom vibration. The three booms produced very similar vibrations in the instrumented shed at the boom site; data are presented here for boom two only, which is typical and representative. In all cases, sensors on the boom side of the shed were subject to vibrations of greater magnitude than corresponding sensors on the lee side; discussion refers mainly to those on the boom side, with the understanding that similar but lesser vibration occurred on the lee side. In general, all sensors were subject to a mixture of transient vibrations of different frequencies, but in most cases there were two predominant frequencies. Figure 17 most clearly shows the lower, and Figure 18, which shows the same data on an expanded time scale, shows the higher frequency. Greatest accelerations of roof and nest boxes tended to occur a few milliseconds after the second rise of a boom when peaks due to the first pulse coincided, by chance, with those of the second.

As the boomward roof slope was struck by each rapid pressure rise, it was near-instantaneously subject to an acceleration of about 2 g. inward. The resulting motion can reasonably be assumed to be a combination of diaphragm deflection of the roof slope and transverse racking of the shed. Thereafter, at the sensor location, the roof vibrated erratically. Two frequencies were recognizable, 230 and 29 Hz. However, these were highly transient, enduring for only a few cycles, and were hardly ever found without other frequencies. They caused maximum displacements from neutral position of 0.002 inch and 0.07 inch, respectively. It is unlikely that these small displacements of the roof could have been sensed visually by the mink. The leeward slope vibrated somewhat less erratically. There was little evidence of synchronous vibration between the two slopes, even though they were joined by a nailed brace every 4 feet.

Boom two was recorded with a range of 2 g. As shown in Figure 17, a few peaks on the boomward roof slope reached or exceeded this. From the direct oscillograph plot, all but one of these were determined to be less than 3 g. The exception was an inward acceleration of the boomward roof slope coincident with the second rapid rise of the boom. Its peak was estimated as 4 g.; this was the maximum acceleration of the structure, and it occurred only once in boom two. The loss of the peak does not seriously degrade the data; the peaks occurred as part of relatively rapid vibration which involved negligible motion. Furthermore, the amount of impulse represented by the peaks caused only a small part of that motion.

It is probable, although not verifiable by these data, that the shed vibrated in an undulating manner; that is, with transverse racking vibrations propagating along the length by moving zones of local plan racking. Such vibrations would be reflected back from the ends, and the resulting interference could account for the erratic nature of the observed vibrations. The pressure impulses resulting from the boom, traversing the shed at a small angle to the longitudinal direction, would tend to induce undulating vibration.

The natural frequency of vibration of the sheds in transverse racking was calculated as between 0.6 and 3 Hz., depending on what degree of stiffening by joints and braces is assumed. This is much less than the lowest frequency found here and is less than can be reliably indicated by these data.

As with the roof slopes, the greatest vibration of nest boxes occurred on the boomward side and was a mixture of transient frequencies. On both sides, in each of three directions, the general pattern was a few cycles of vibration at about 330 Hz. following each rapid pressure rise, along with several cycles of a much lower frequency. At the higher frequency, the transverse direction had greatest acceleration, and the longitudinal direction had least. However, displacement from neutral calculated for the greatest acceleration was only 0.00004 inch, probably not sensed by the mink. At the lower frequency, about 10 Hz., the vertical direction had the greatest acceleration, although in the longitudinal direction the vibration lasted longer. Greatest displacement from neutral was calculated as 0.12 inch, where maximum acceleration was 0.5 g. The nest boxes were thus moved in all three directions with a complex motion of predominantly 10 Hz., but mixed with other frequencies, reaching total cyclic movements of about 0.24 inch and lasting about 0.5 second. This probably was the natural frequency for the instrumented nest box suspended on the inward escape-proofing mesh. There can be little doubt that the mink sensed this vibration. It was similar, but of greater amplitude, to that resulting from vigorous activity by mink in adjacent cages.

The flight track very nearly coincided with the island shoreline for several miles approaching the site. The terrain was a mixture of spruce forest over rock hills, dense rain forest, muskeg, and outwashed gravel and silt. Any seismic disturbances created by a boom on the approach would arrive at the site before the boom. Assuming gross uniformity of the substrata along the flight track for seismic excitation and transmittance, disturbances caused by the boom would show increasing amplitude on the accelerometer traces as time approached boom incidence at the site. At that instant, seismic effect on the accelerometers would be maximum but be confounded with the structural motion induced directly from the air. However, the plots show hardly any disturbance before boom incidence. What little there is seems to be a sinusoidal variation of about 0.02 g., barely detectable at the instrument setting used. Seismic effects were negligible relative to directly induced structural motion.

Blast vibration. Figure 19 shows vibrations of the shed caused by the roadbuilding blast. Roof and nest boxes were affected similarly by low frequencies of about 13 Hz., varying somewhat between measurement directions. Maximum acceleration was 0.05 g., and maximum displacement from neutral was about 0.0024 inch, in each measurement direction of the nest boxes. No vibrations preceding the air pressure waveform were detected. Therefore, seismic effects of the blast were negligible at the scale of measurement used here.

Simulated boom vibration. Vibration induced by the first simulated boom **Figures 20 and 21, was similar but of lesser amplitude and** duration than that of the real booms. On the roof slopes, maximum acceleration was 1.2 g., but only a few peaks exceeded 0.5 g. Recognizable transient frequencies were 470, 400, 200, 56 Hz. Motion was very small; greatest displacement from neutral, due to the lowest frequency, was 0.0001 inch. Roof vibration was mostly complete after 0.7 second.

The nest boxes tended to vibrate at a single higher frequency in each measurement direction; no acceleration exceeded 0.6 g. On both sides of the shed, the transverse direction had the greatest acceleration and the vertical direction had little. The higher frequencies found were 700, 470, 200 Hz. The lee side alone had a recognizable lower frequency, about 20 Hz. In the longitudinal direction, this caused a maximum displacement from neutral of 0.0012 inch, or total cyclic movement of 0.0024 inch. Nest box vibrations were mostly complete after 0.3 second.

## SUMMARY

The mink were housed in similar conditions at three test sites. Individual wire cages were 4.5 feet above ground under peaked shed roofs. Wood nest boxes were attached, and almost all of the mink were in these during tests. The boom site received three sonic booms of about 6 pounds per square foot peak overpressure. The booms also directly caused transient structural vibrations of the shed roof with accelerations over 2 g. (acceleration of gravity) but accelerations of the nest boxes did not exceed 1 g. The main motion of the nest boxes was a vibration at 10 Hertz with maximum total movement of about 0.24 inch. Seismic effects of the booms on the sheds were negligible. The simulator site received three simulated booms with an average of 3.5 pounds per square foot peak overpressure. Maximum acceleration of the roof was 1.2 g., and of the nest boxes, 0.5 g. Maximum total movement of nest boxes was about 0.0024 inch. The control site received no booms, and all three sites received similar ambient noises such as road traffic.

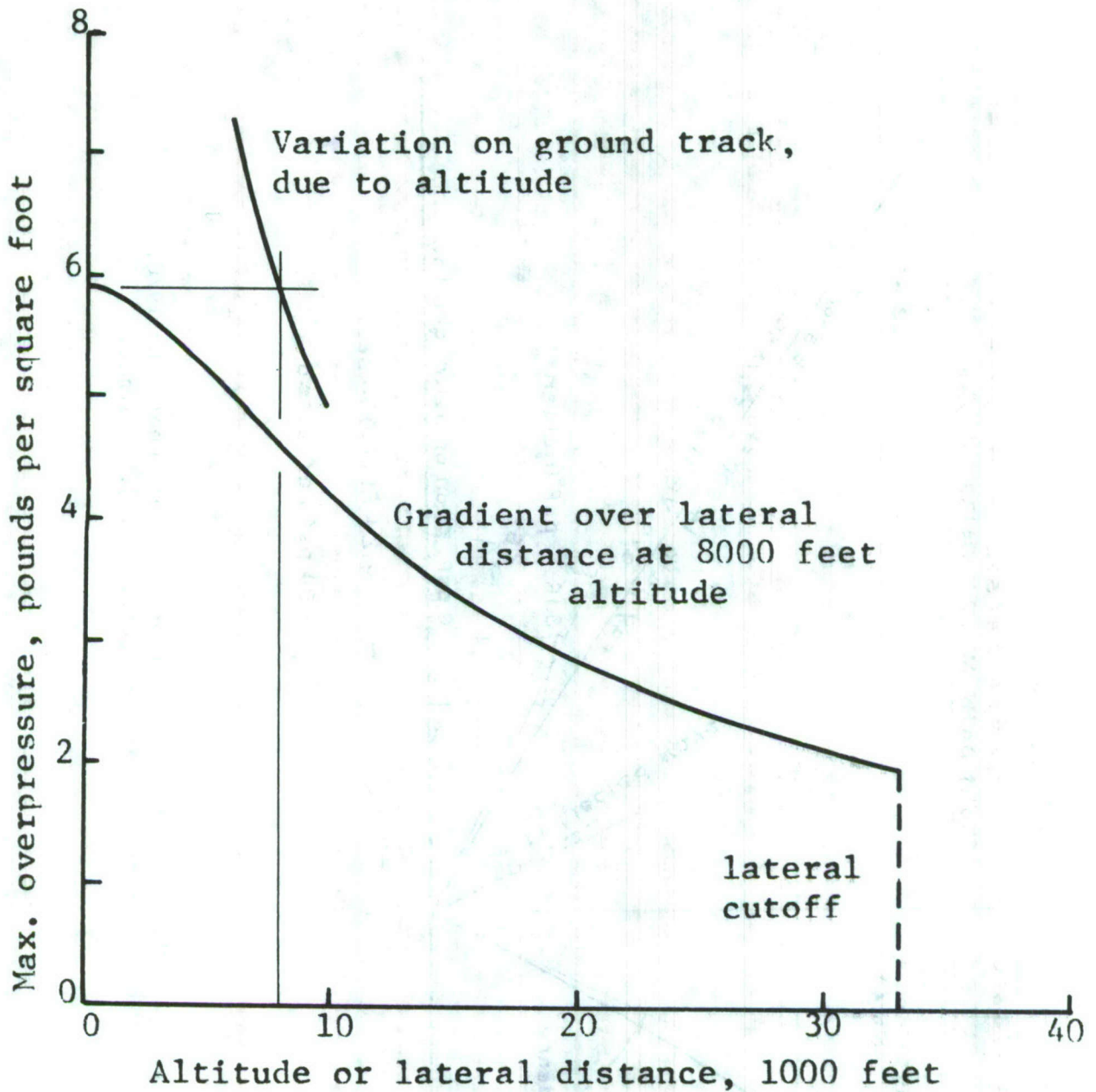

Figure 1.--Stable flight conditions to make a sonic boom of 6 pounds per square foot maximum overpressure; F4E airplane with full internal fuel and no external stores, weight 40,000 pounds; speed Mach 1.2, altitude 8,000 feet. Ground reflection coefficient 1.9 assumed. From technical data by NASA-Langly Research Center.

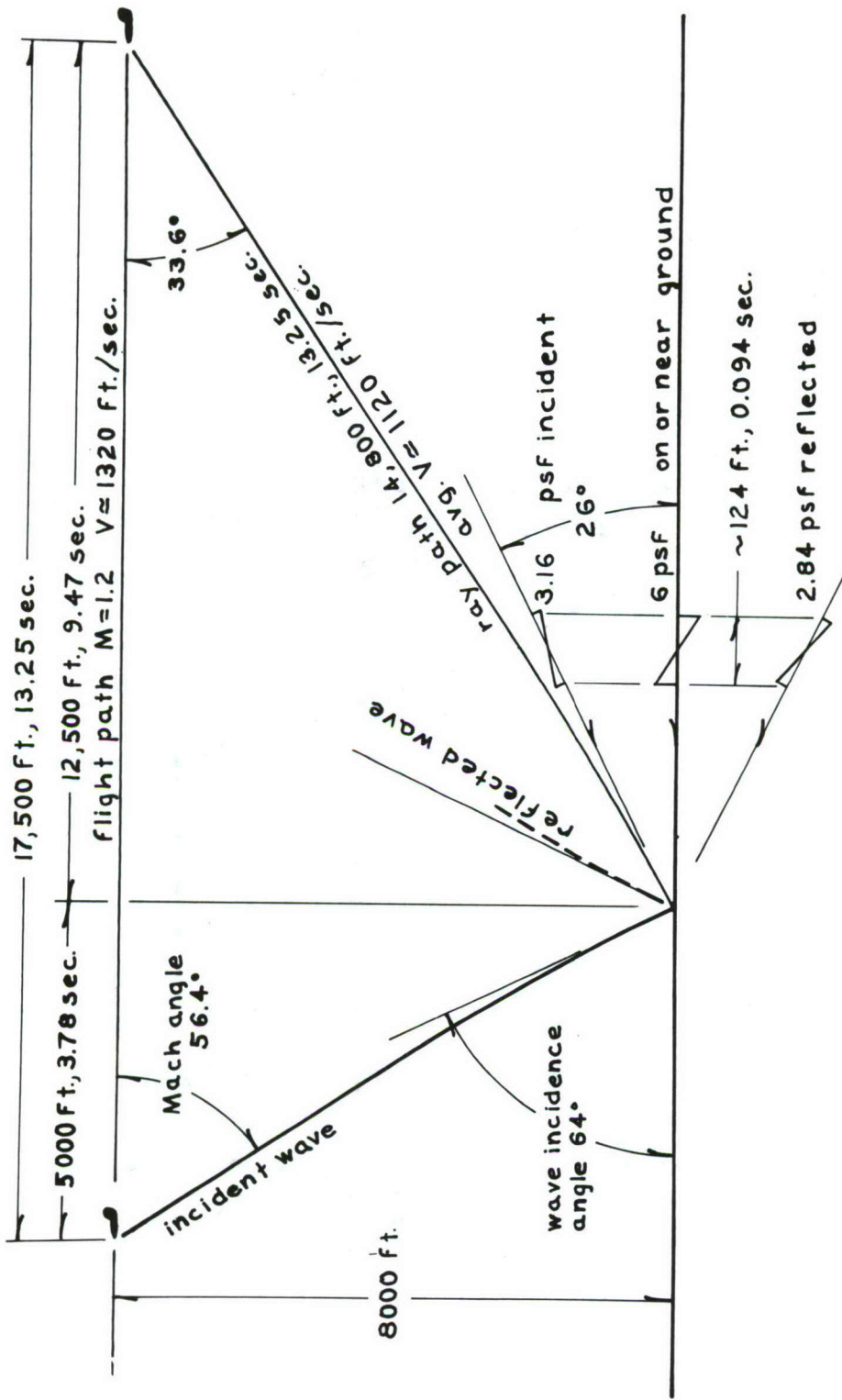

Figure 2.--Geometry of sonic boom propagation, Cool Mink 1970.  
Ground surface reflection coefficient 1.9 assumed.

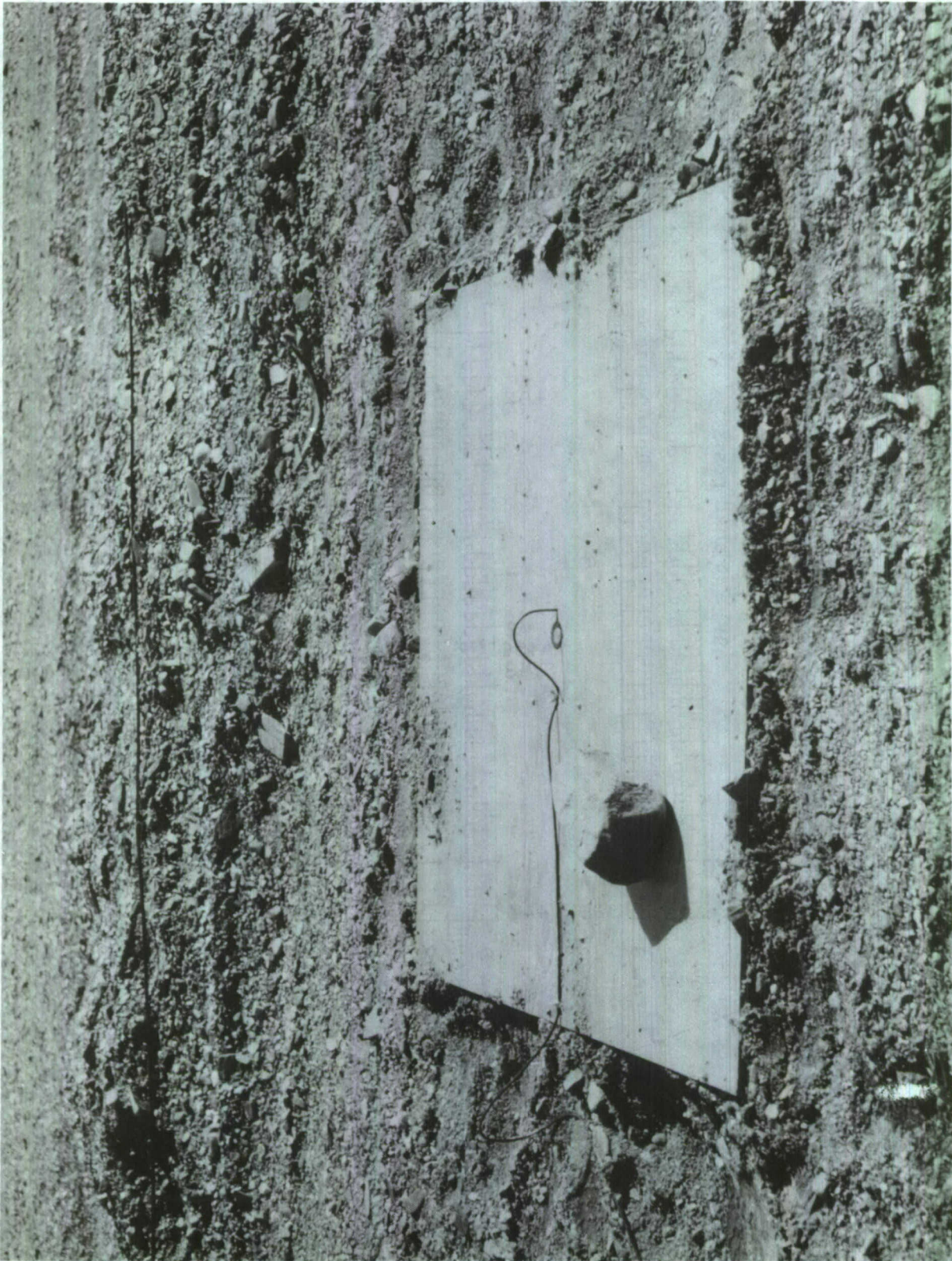

Figure 3.--Microphone in ground plane board.

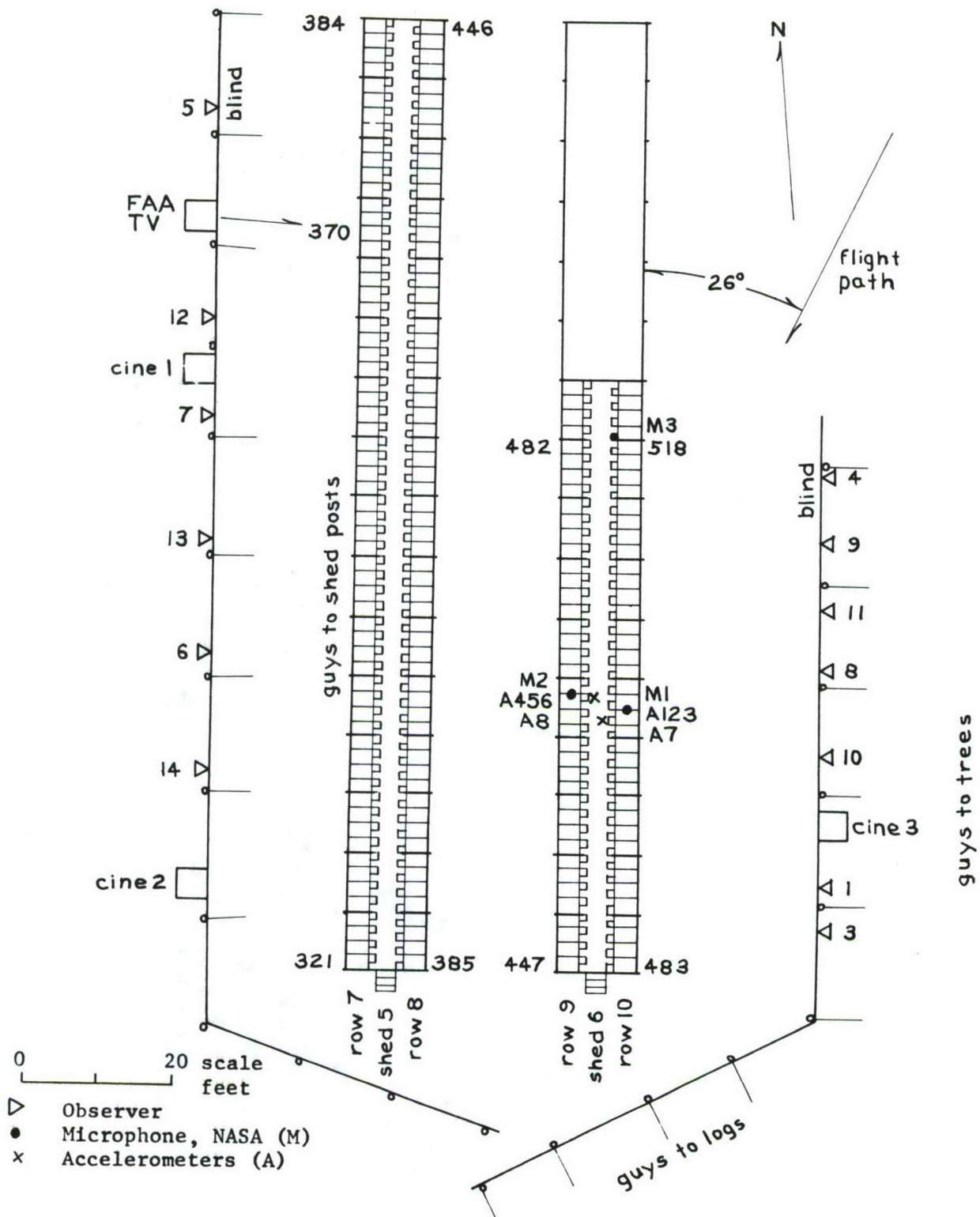

Figure 4.--Plan of boom site, Sumner Strait, Mitkof Island, Alaska. Guy wires from tops of blind posts to noted ground points; cage numbers at row ends.

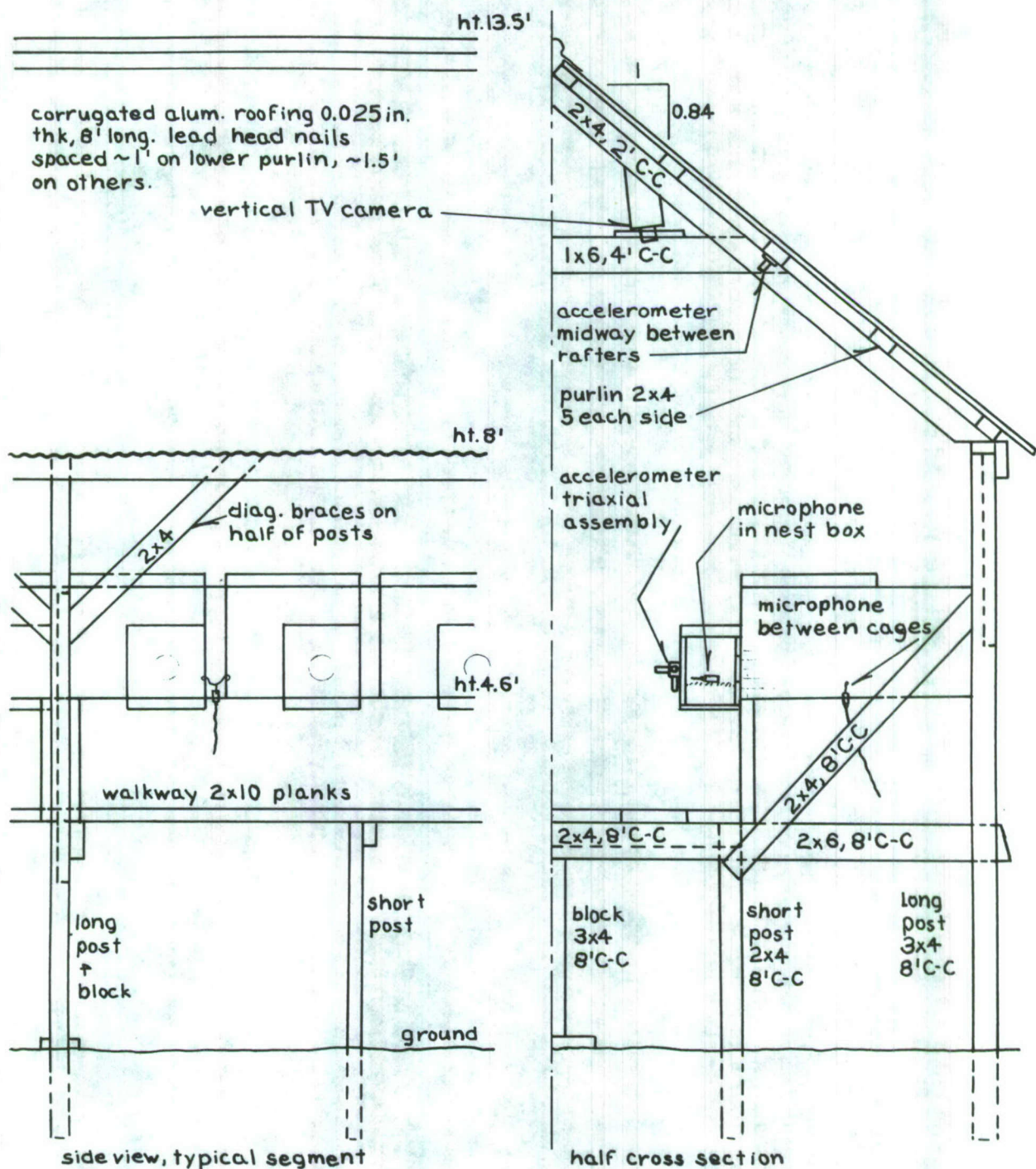

Figure 5.--Structural details of sheds and sensor locations.

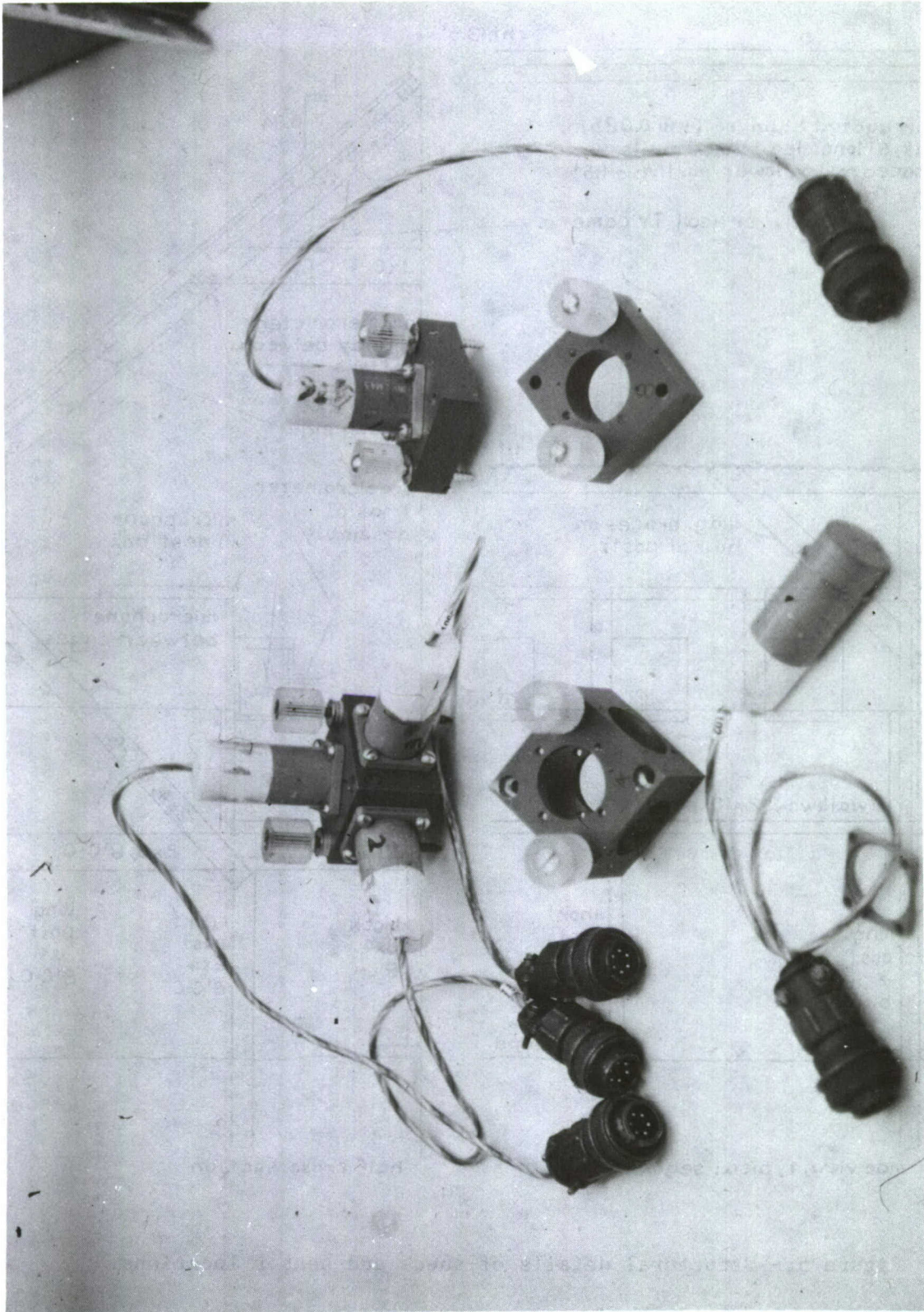

Figure 6.--Accelerometers and mounts for quick attachment.

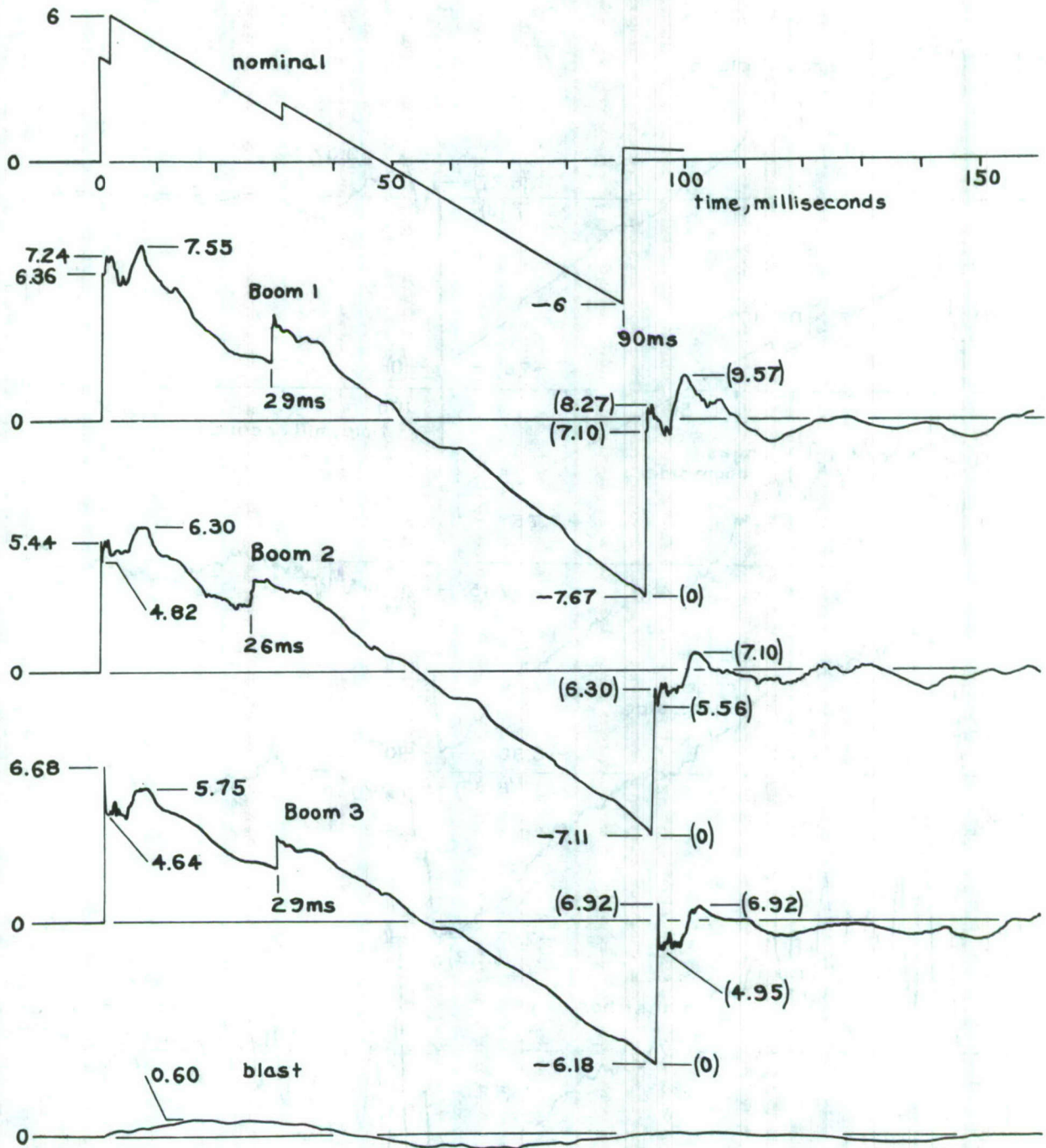

Figure 7.--Pressure-time waveforms of 3 booms measured on unobstructed ground plane. Numbers are overpressure in pounds per square foot re ambient or (negative peak); significant times in milliseconds (ms), both rises of all 3 booms: Peak of rapid rise - 0.2 ms; following low - 0.7 ms; maximum overpressure - 7 ms. Duration between rises - 94 ms. Nominal waveform by NASA-Langly Research Center. Blast from roadbuilding.

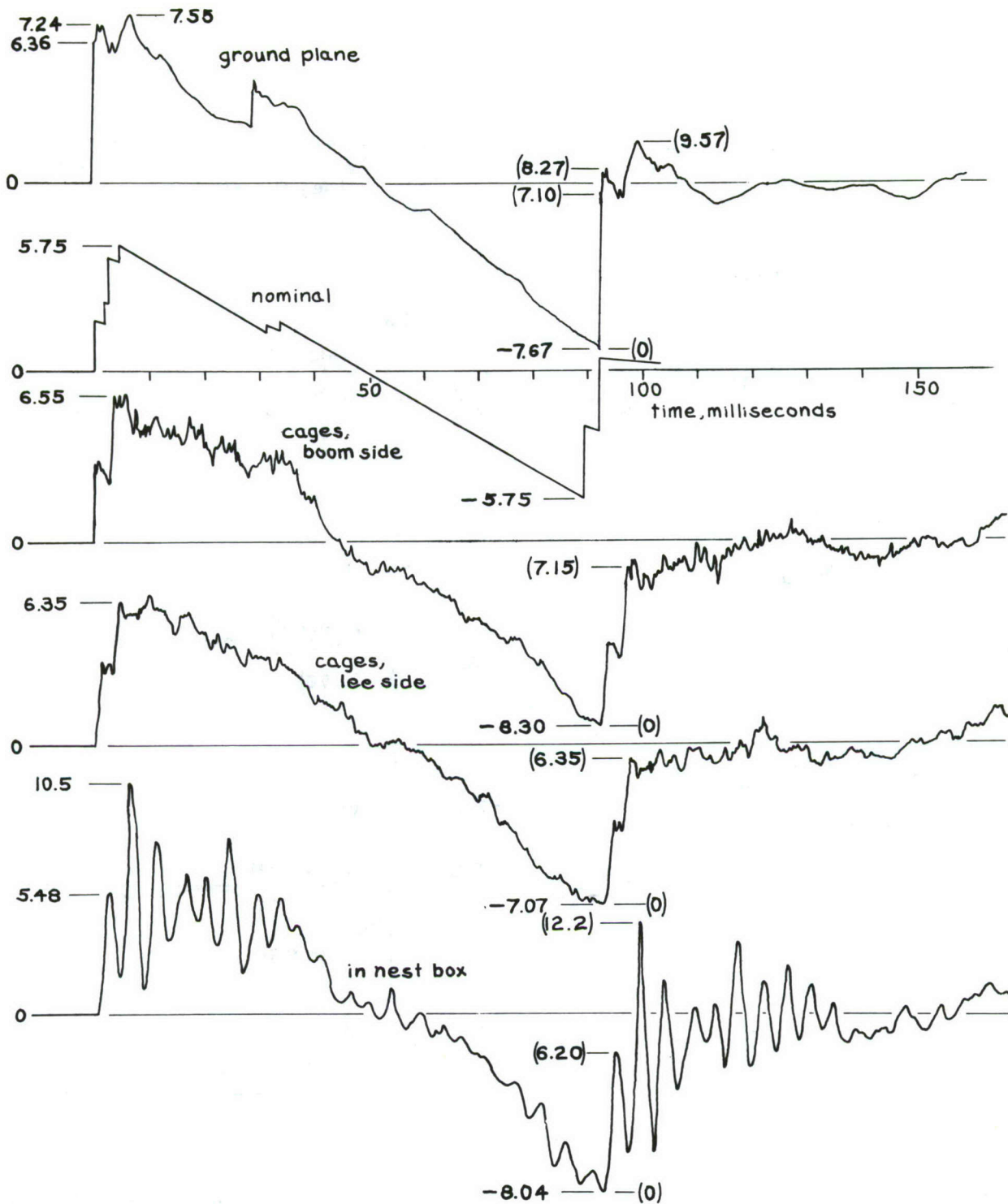

Figure 8.--Pressure-time waveforms of Boom 1 measured at noted locations. Ground plane same as in Figure 7. Nominal derived from Figure 7, with 1.9 reflectivity, 3.6 millisecond lag. Numbers are overpressure in pounds per square foot re ambient or (negative peak).

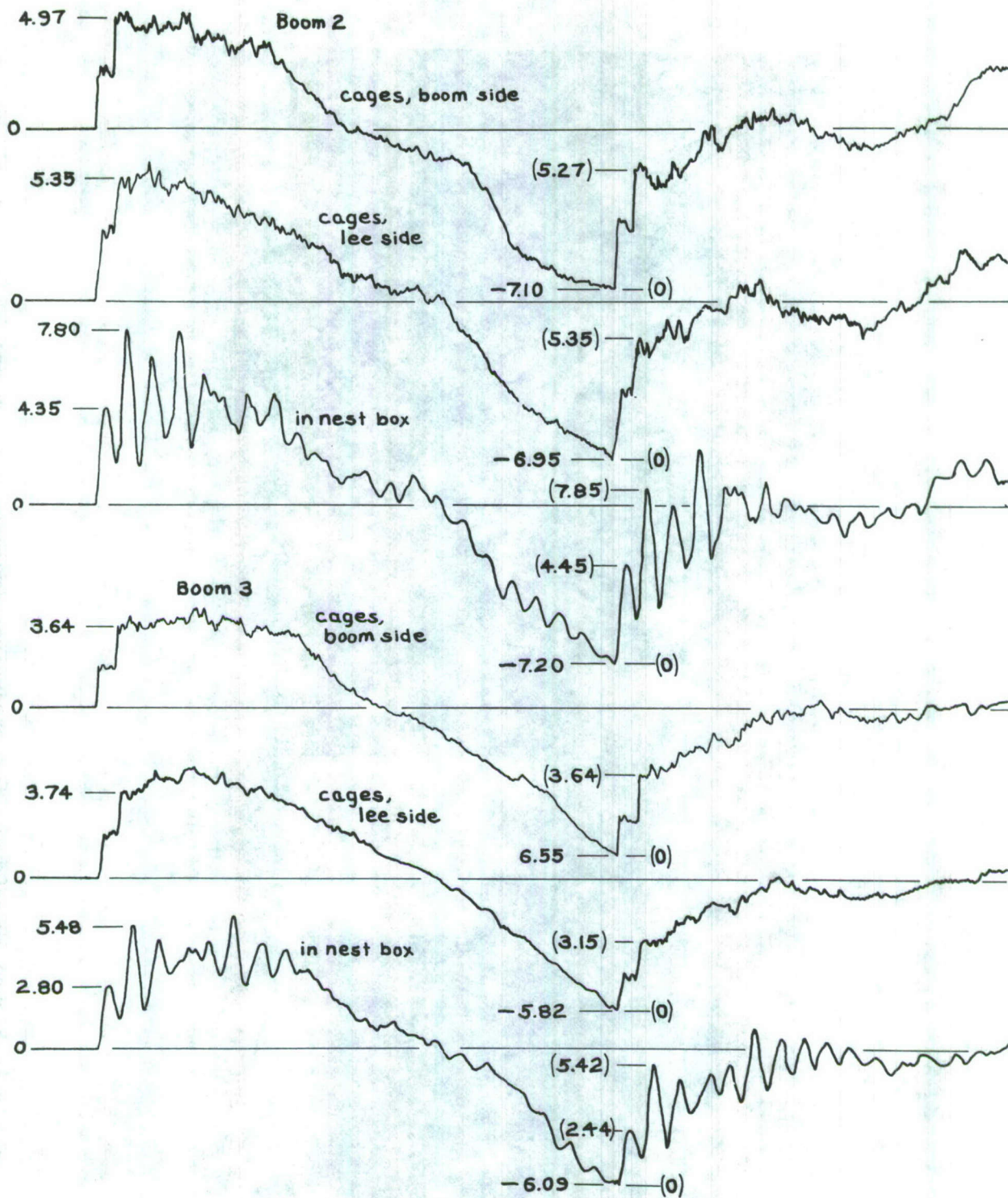

Figure 9.--Pressure-time waveforms of Booms 2 and 3, measured at noted locations. Numbers are overpressure in pounds per square foot re ambient or (negative peak).

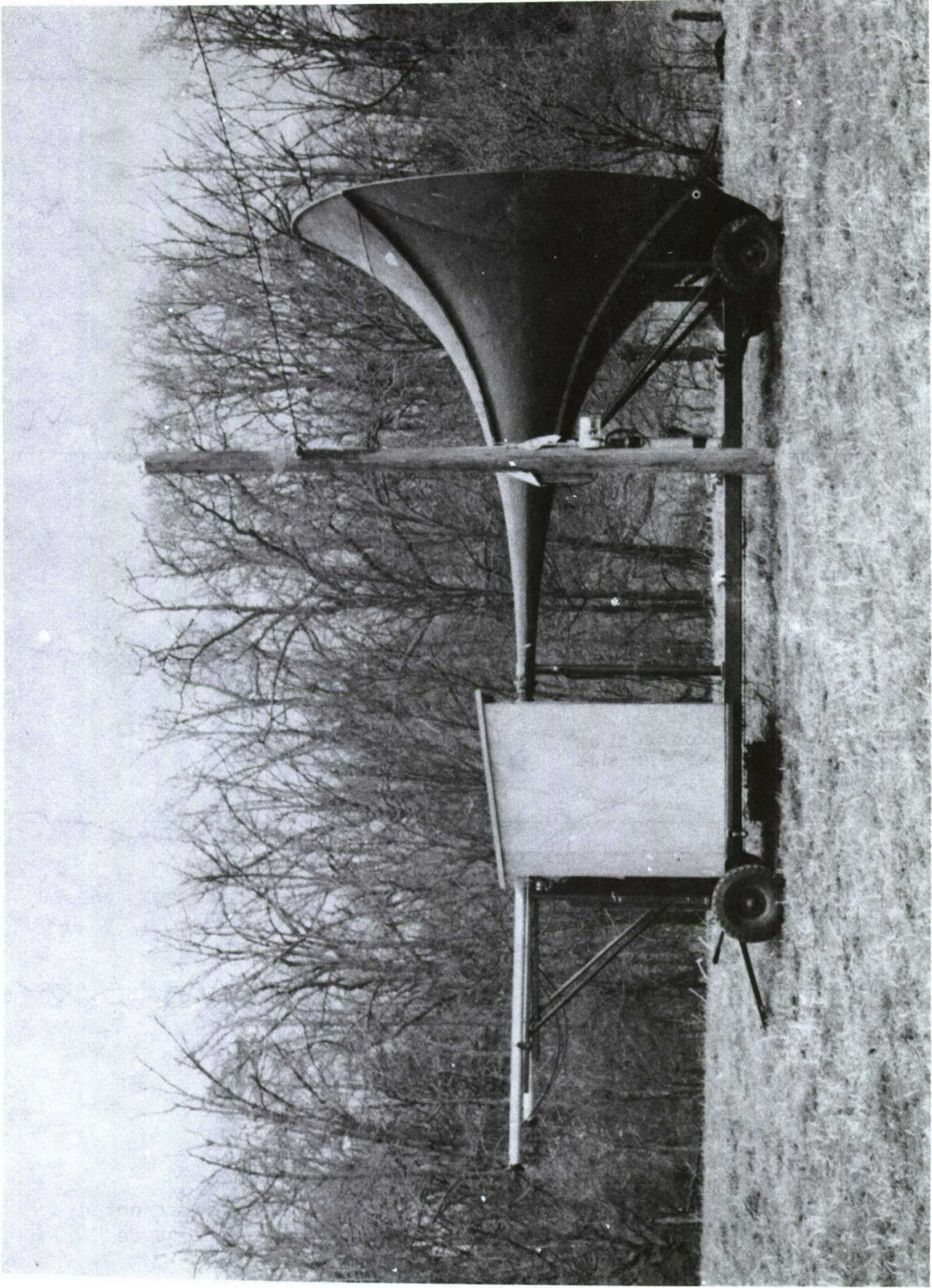

Figure 10.--Device for producing simulated sonic booms.

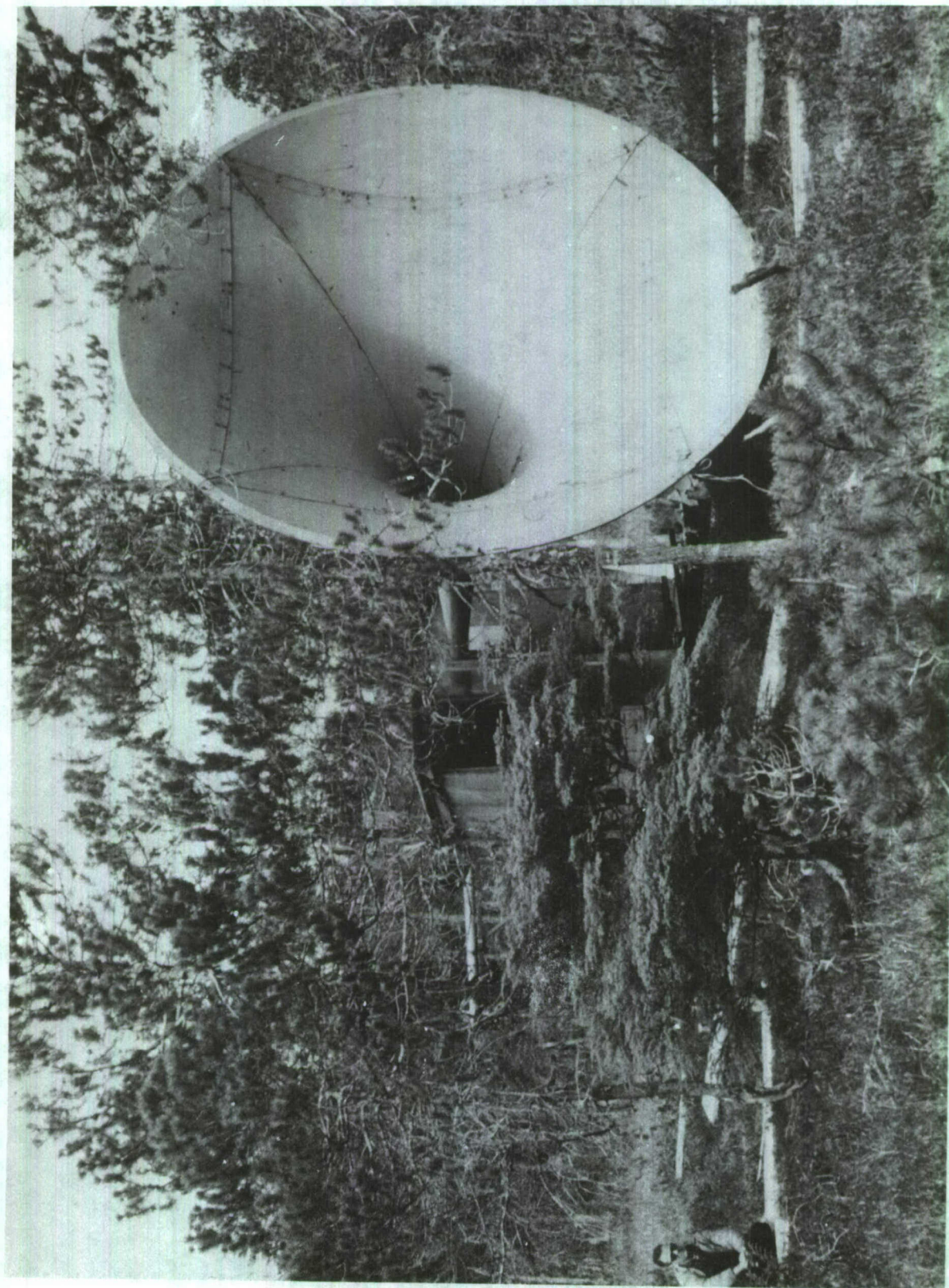

Figure 11.--Simulator in place at site in Alaska.

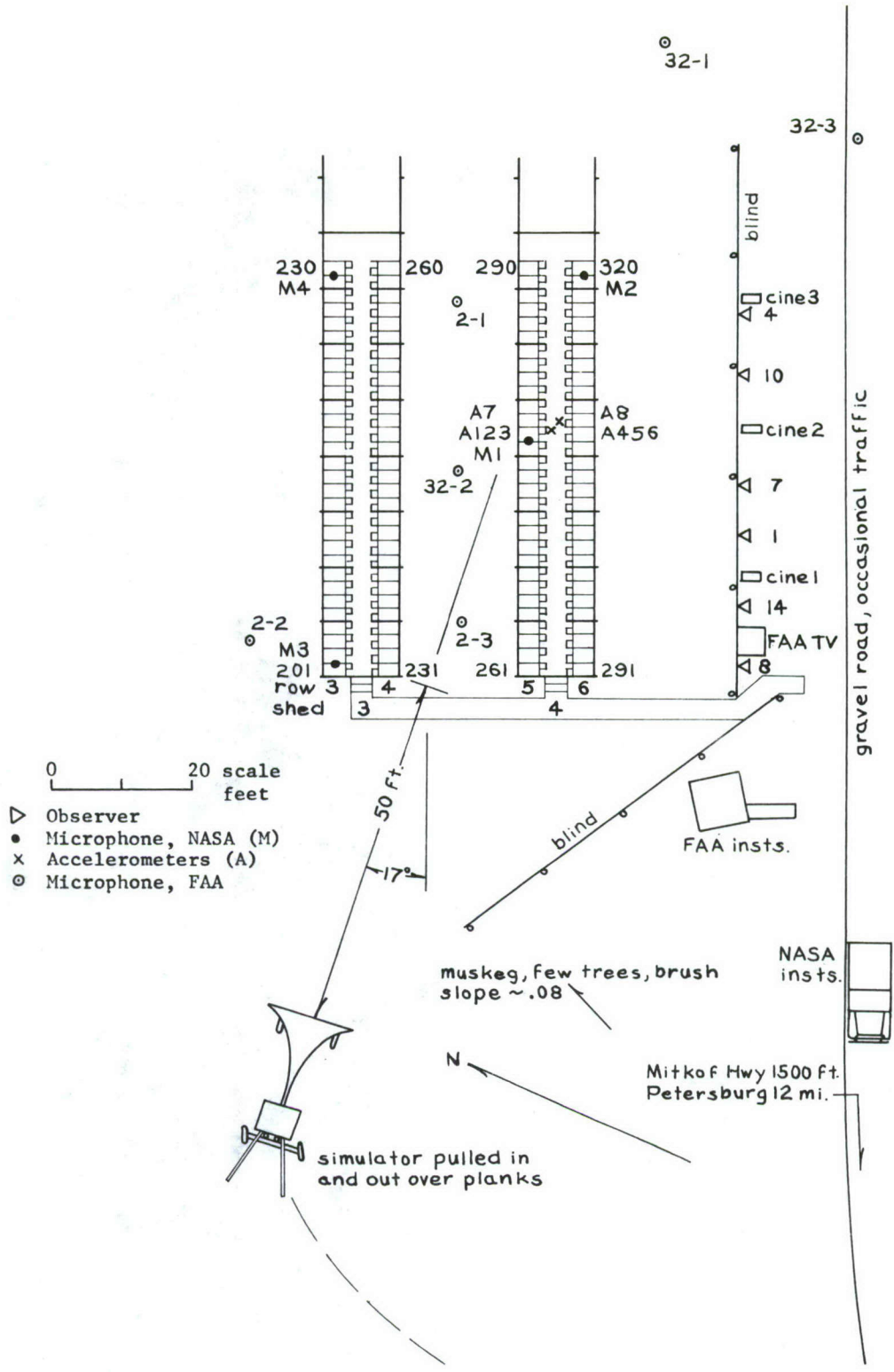

Figure 12.--Plan of simulator site, Falls Creek, Mitkof, Island, Alaska.  
 Cage numbers at row ends.

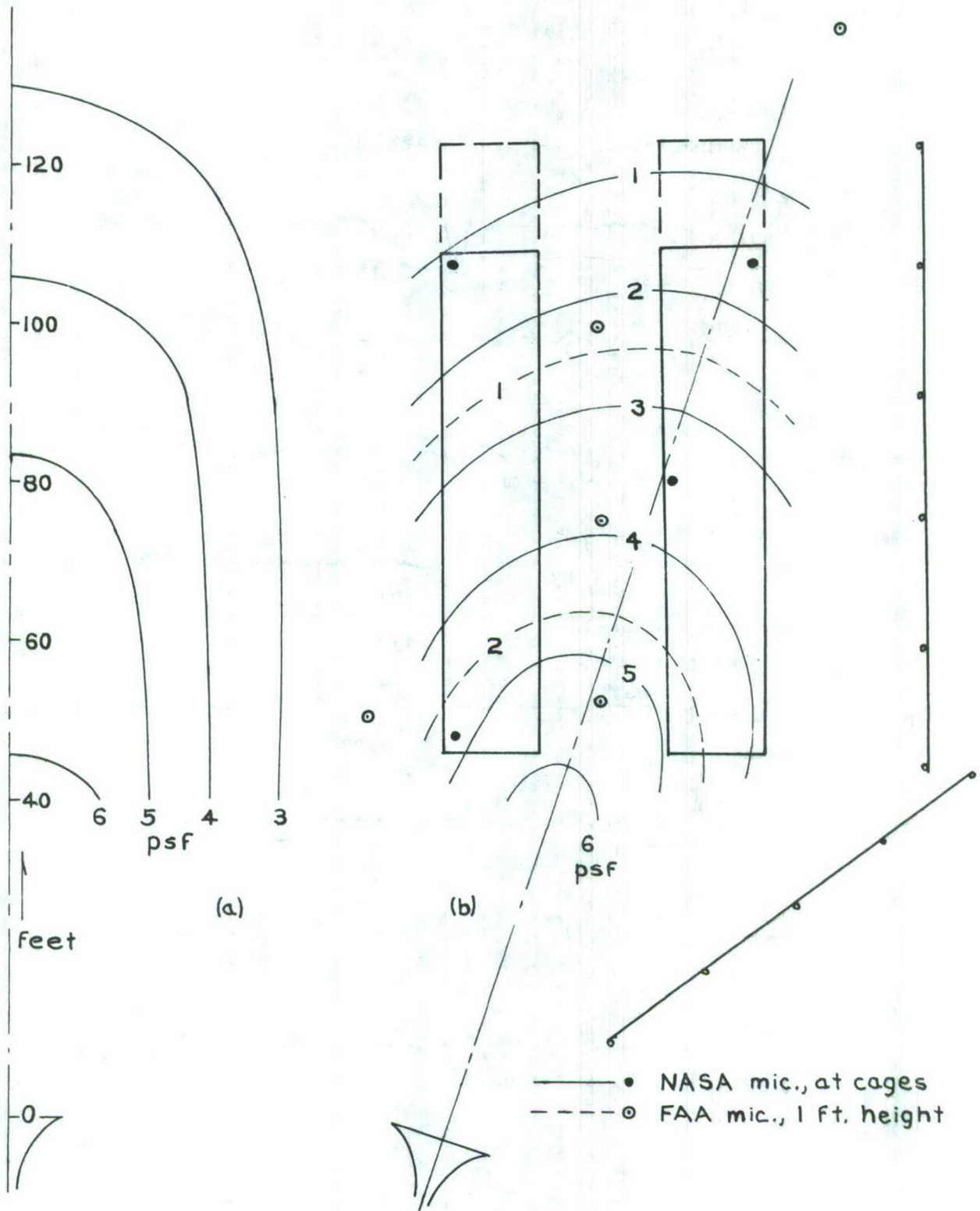

Figure 13.--Peak overpressure field of sonic boom simulator, in pounds per square foot. (a) Clear field calibration, 4 feet above level gravel; (b) Simulated Boom 1, 12 May 70.

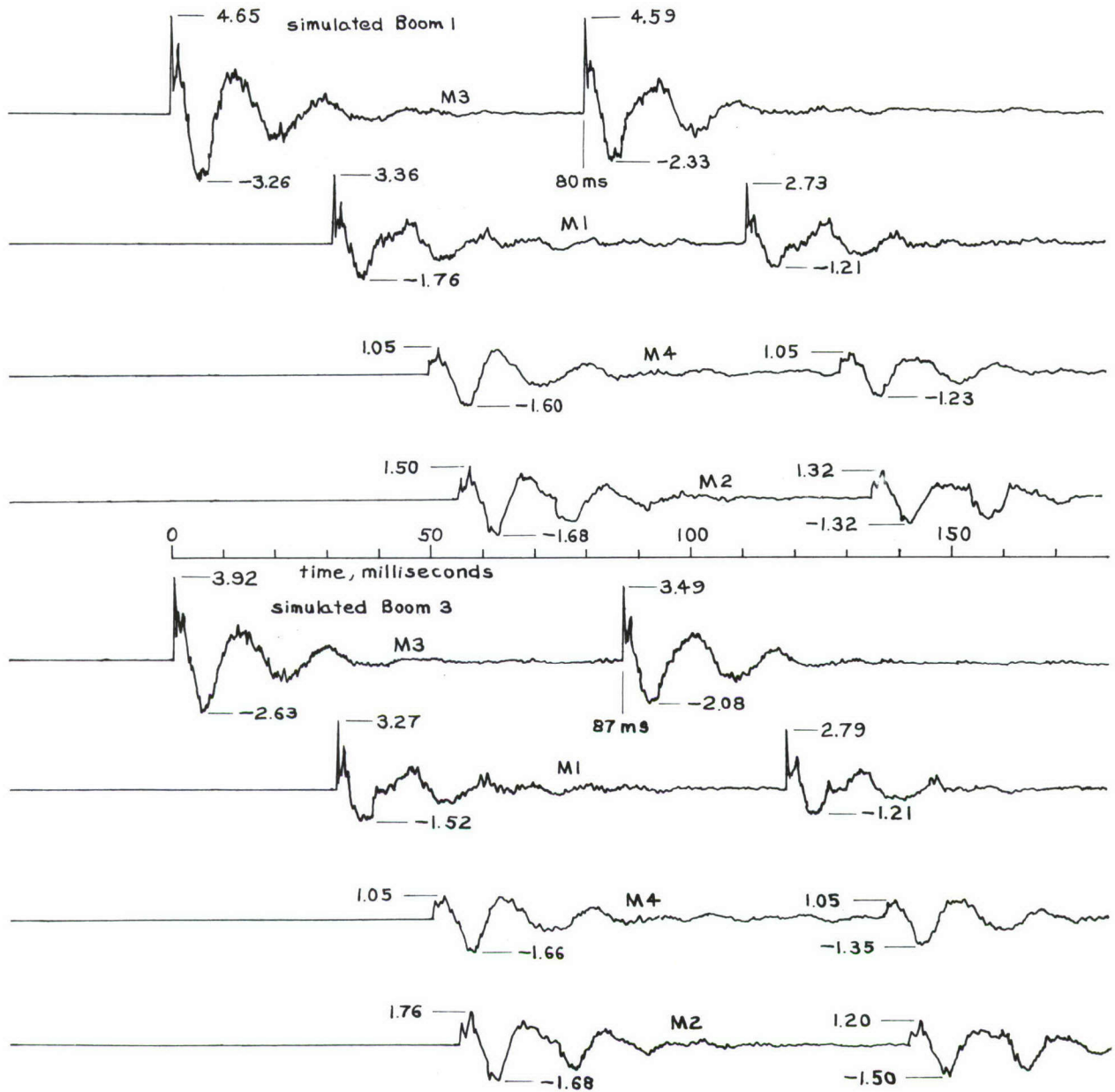

Figure 14.--Pressure-time waveforms of simulated Booms 1 and 3; microphones at four locations in mink sheds as on simulator site plan; numbers are over-pressure in pounds per square foot. Rise times - 0.4 millisecond.

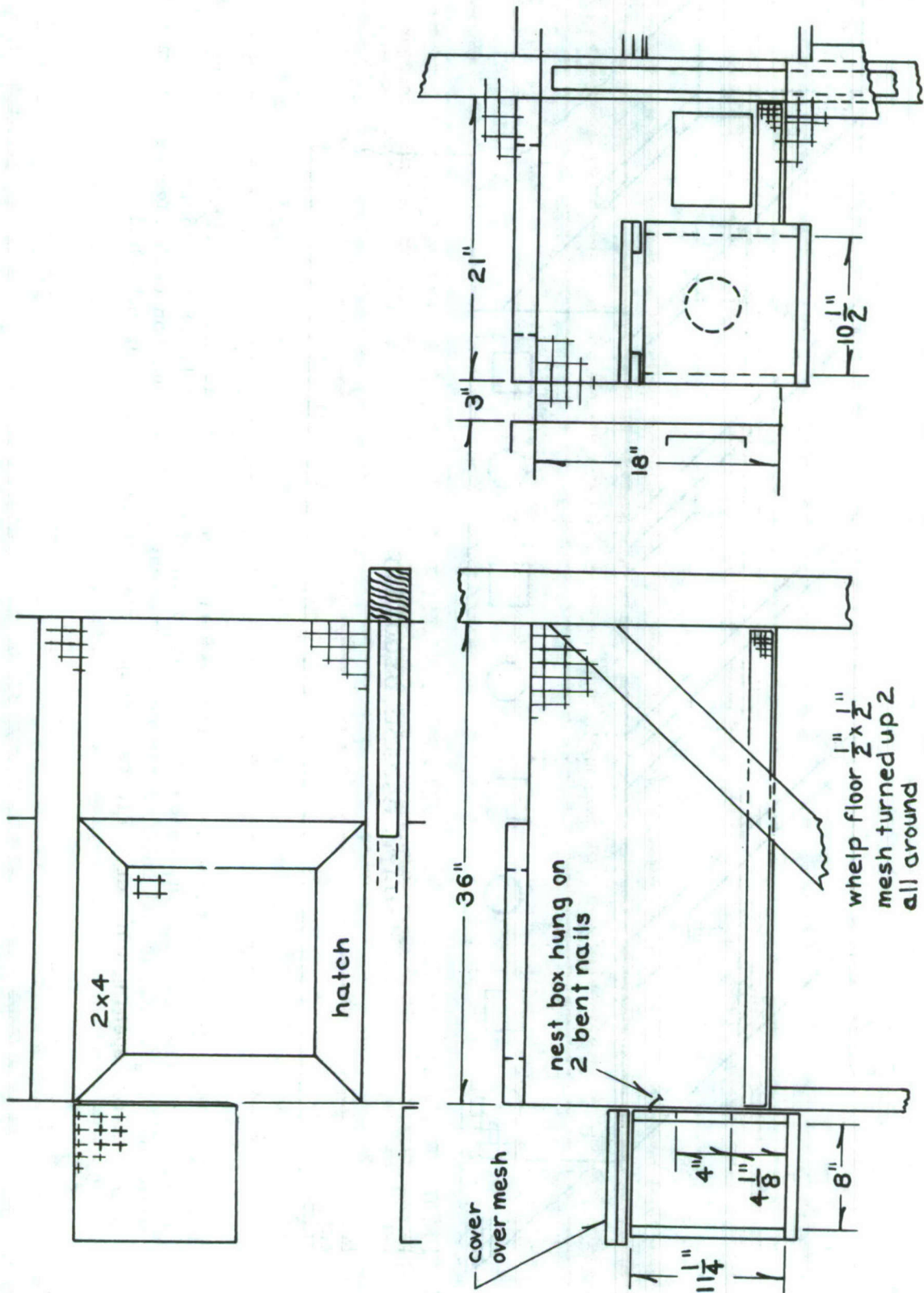

Figure 15.--Details of cage and nest box. Cages of welded wire mesh 1x1.5 inch. Nest boxes of boards 3/4 inch thick.

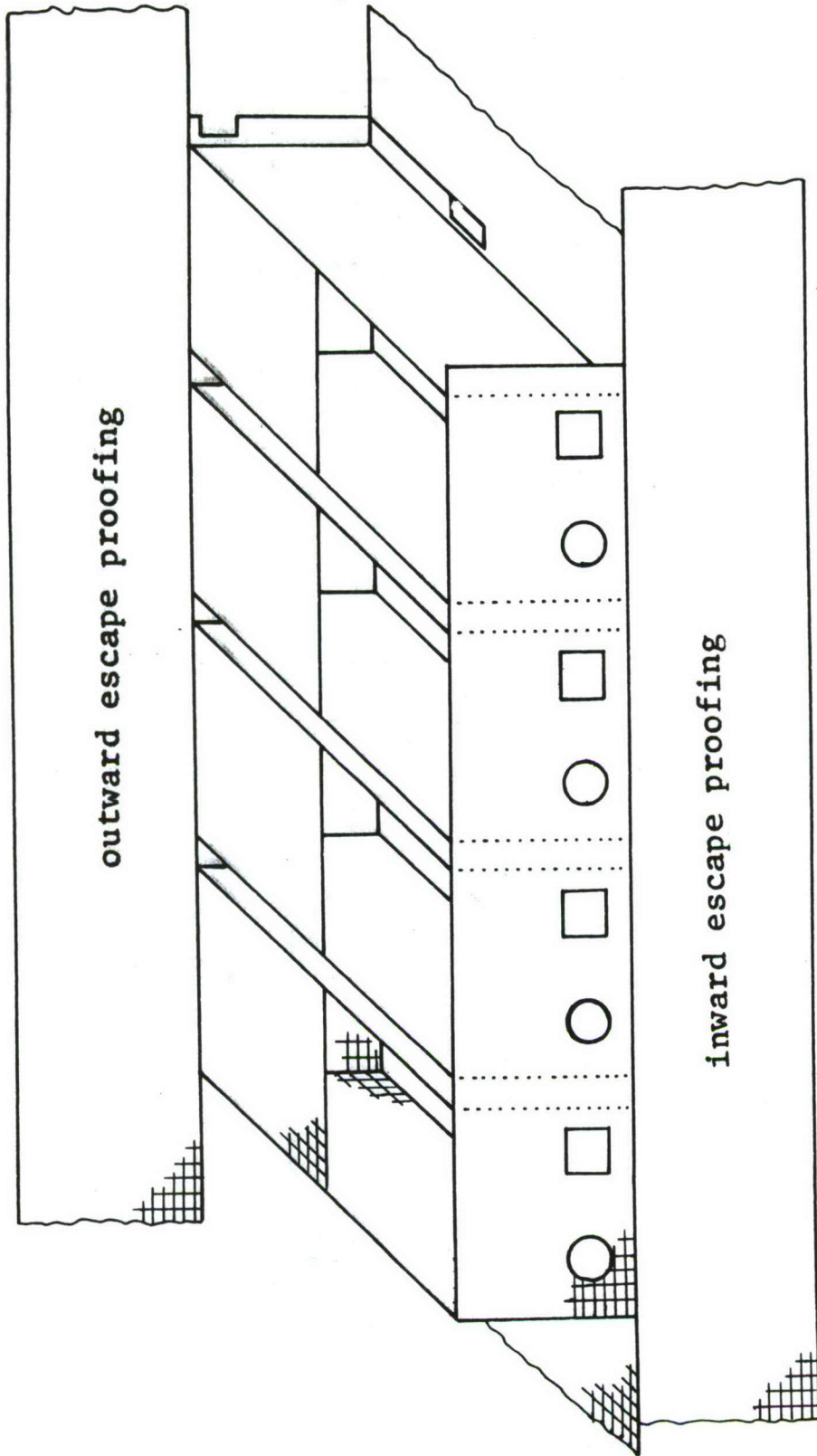

Figure 16.--Assembly of 4 cages as installed. Supported by posts at ends and escape proofing. All rectangular mesh 1x1.5 inch, welded wire 0.080 inch diameter, widths 18 and 36 inch. Fastened with hog rings. Front and back continuous over 4 cages. Sides and top each cage best from single piece, hatch opening cut out. Floors, escape proofing continuous through shed.

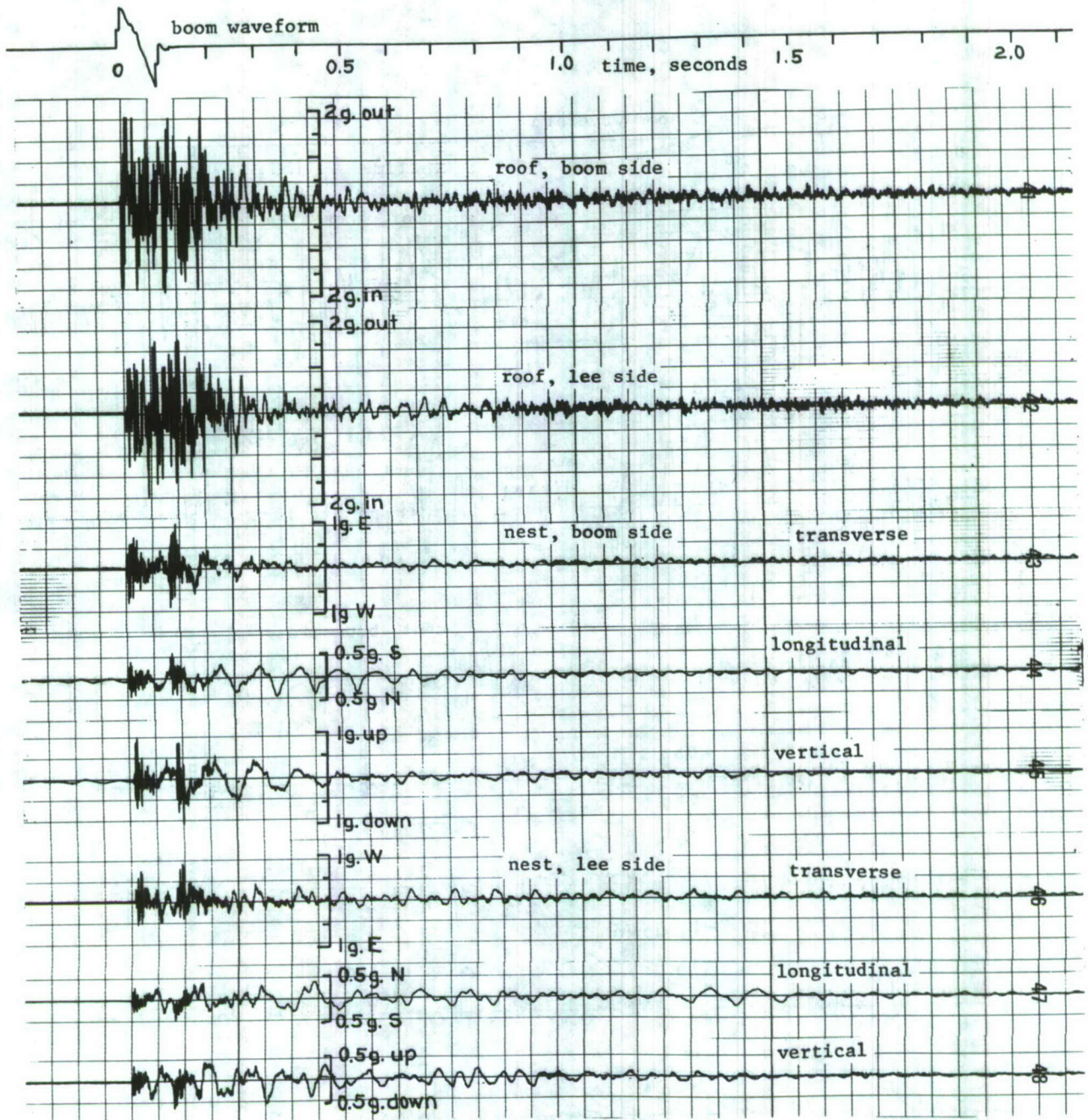

Figure 17.--Accelerations of shed 6 by Boom 2, chart speed 3.15 inches per second.

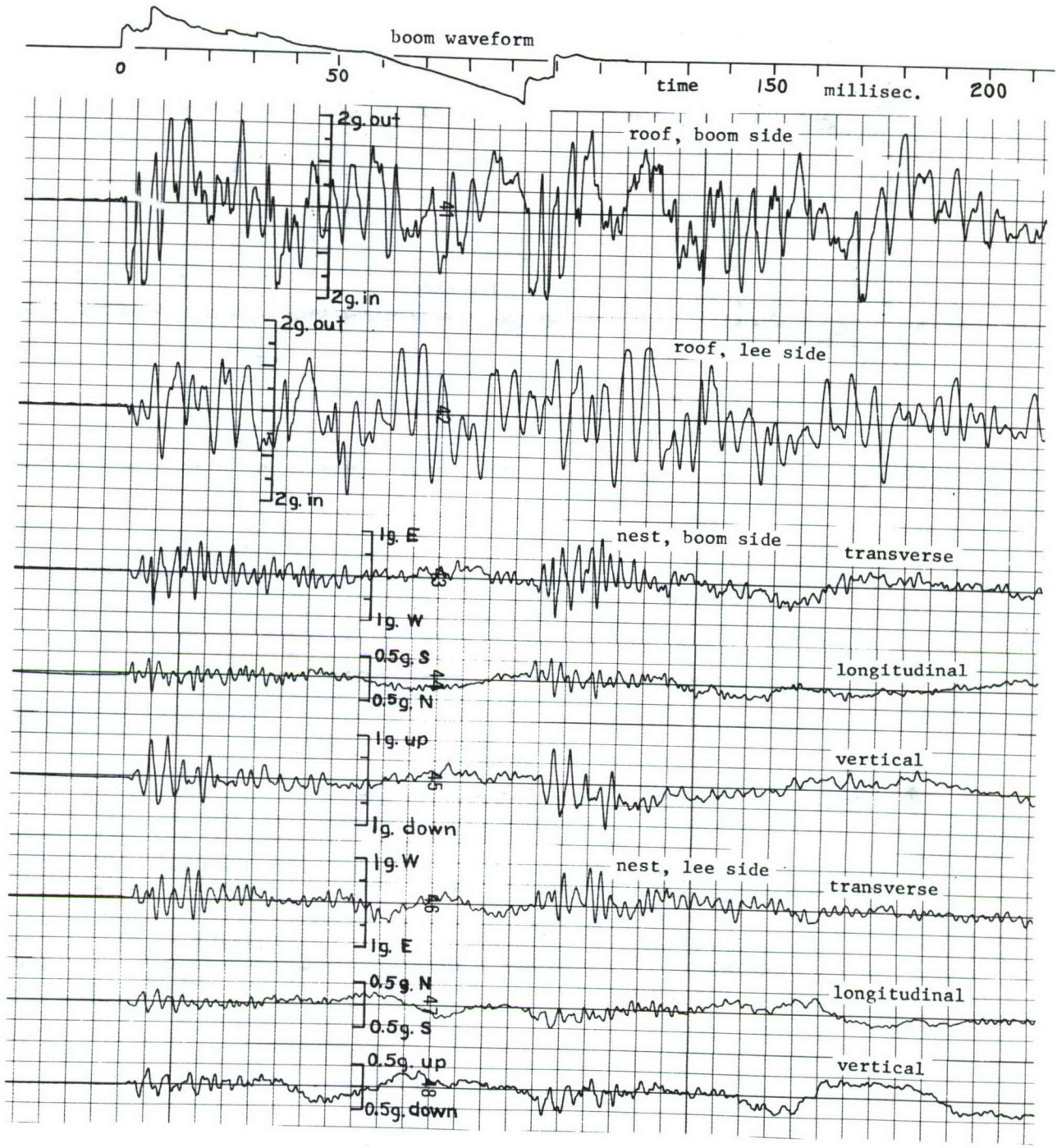

Figure 18.--Accelerations of shed 6 by Boom 2,  
 chart speed 31.5 inches per second.

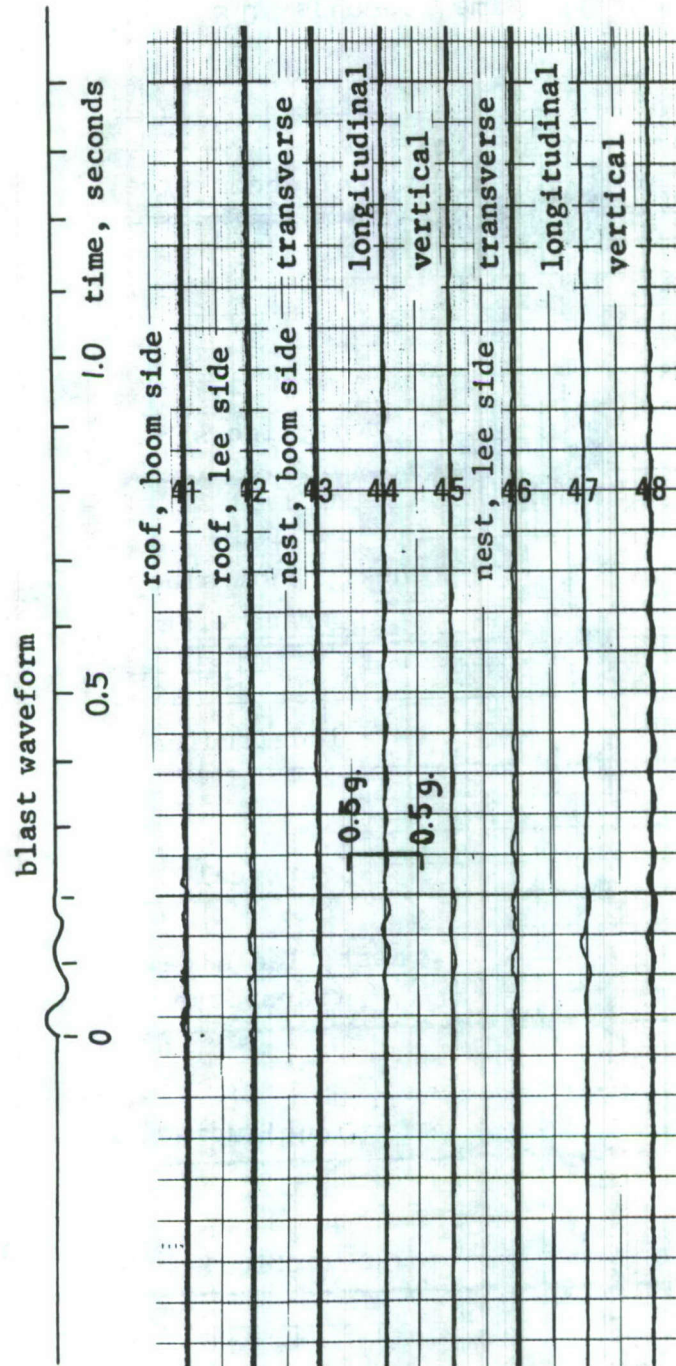

Figure 19.--Accelerations of shed 6 by roadbuilding blast, chart speed 31.5 inches per second.

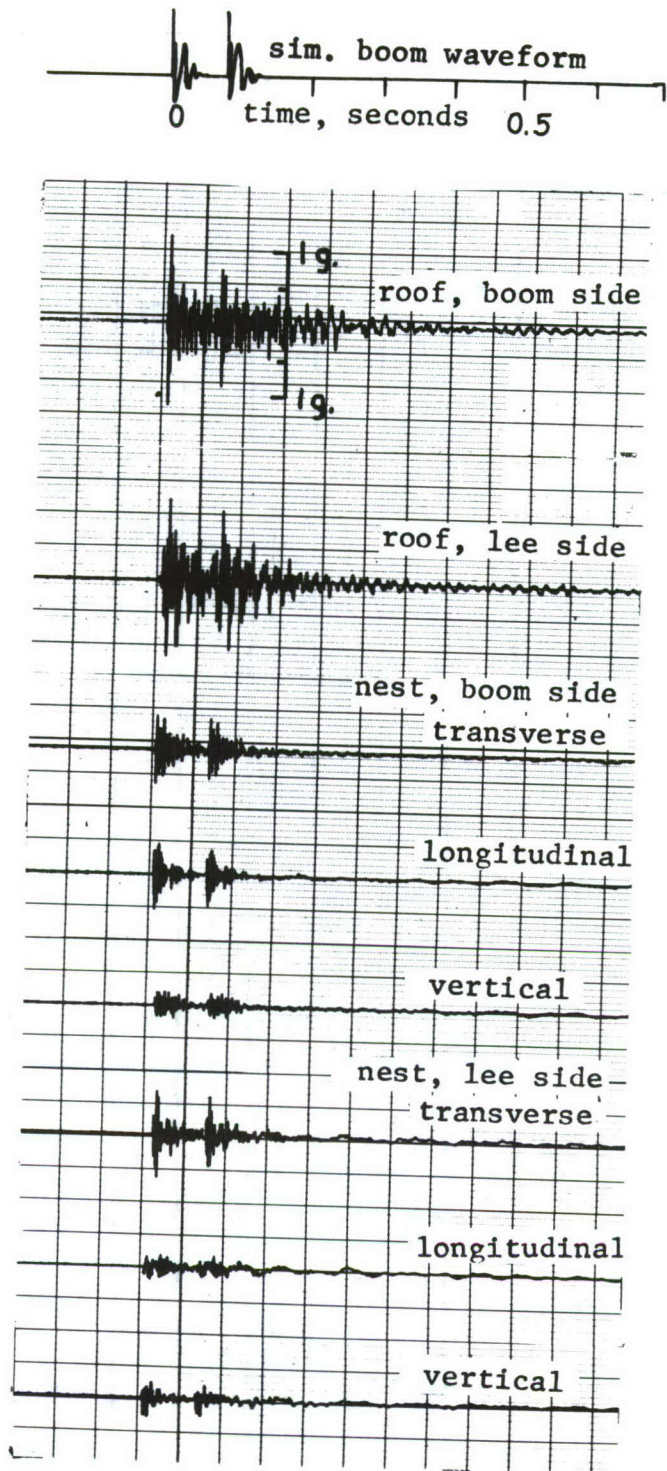

Figure 20.--Accelerations of shed 4 by simulated Boom 1, chart speed 3.15 inches per second.

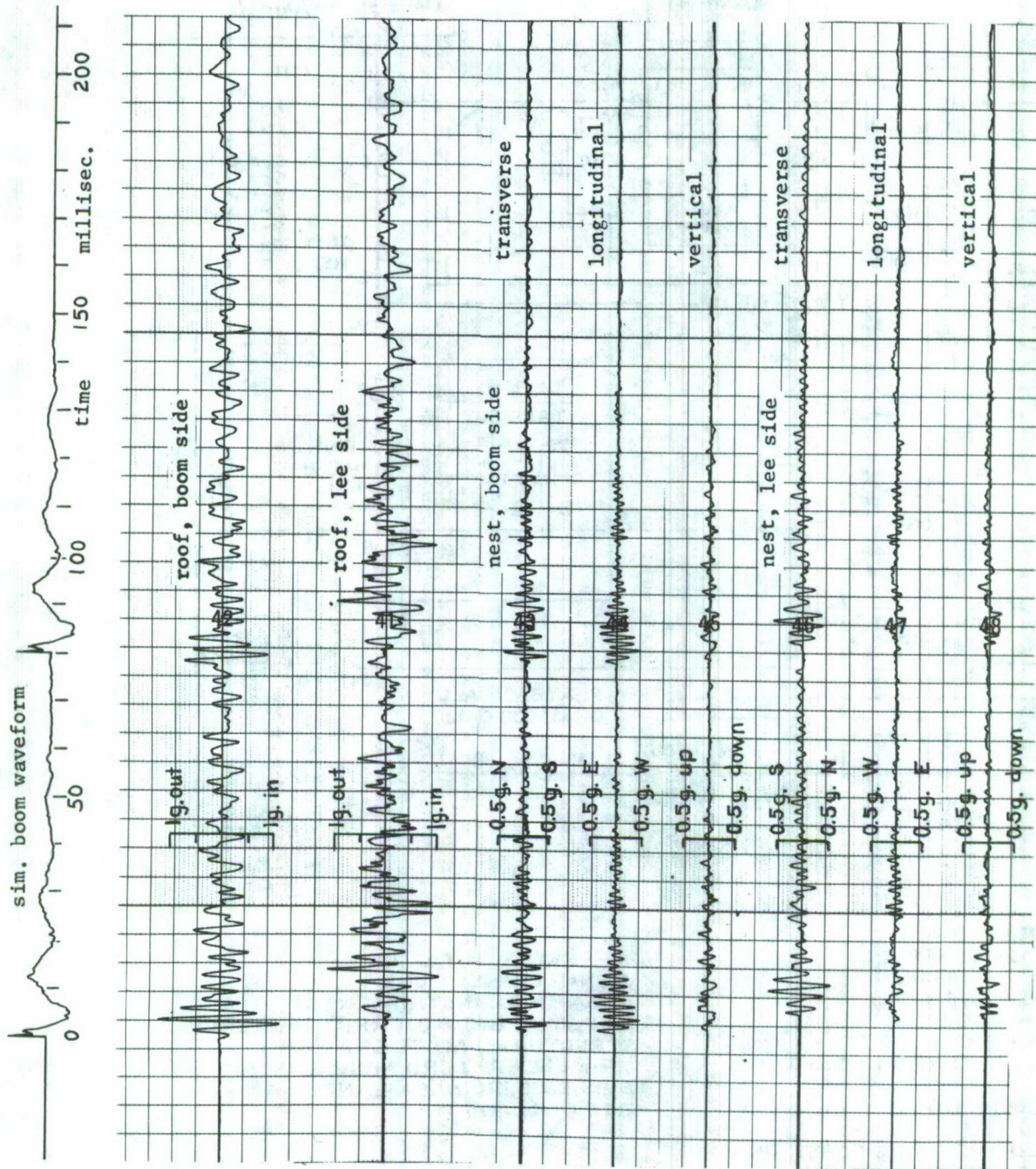
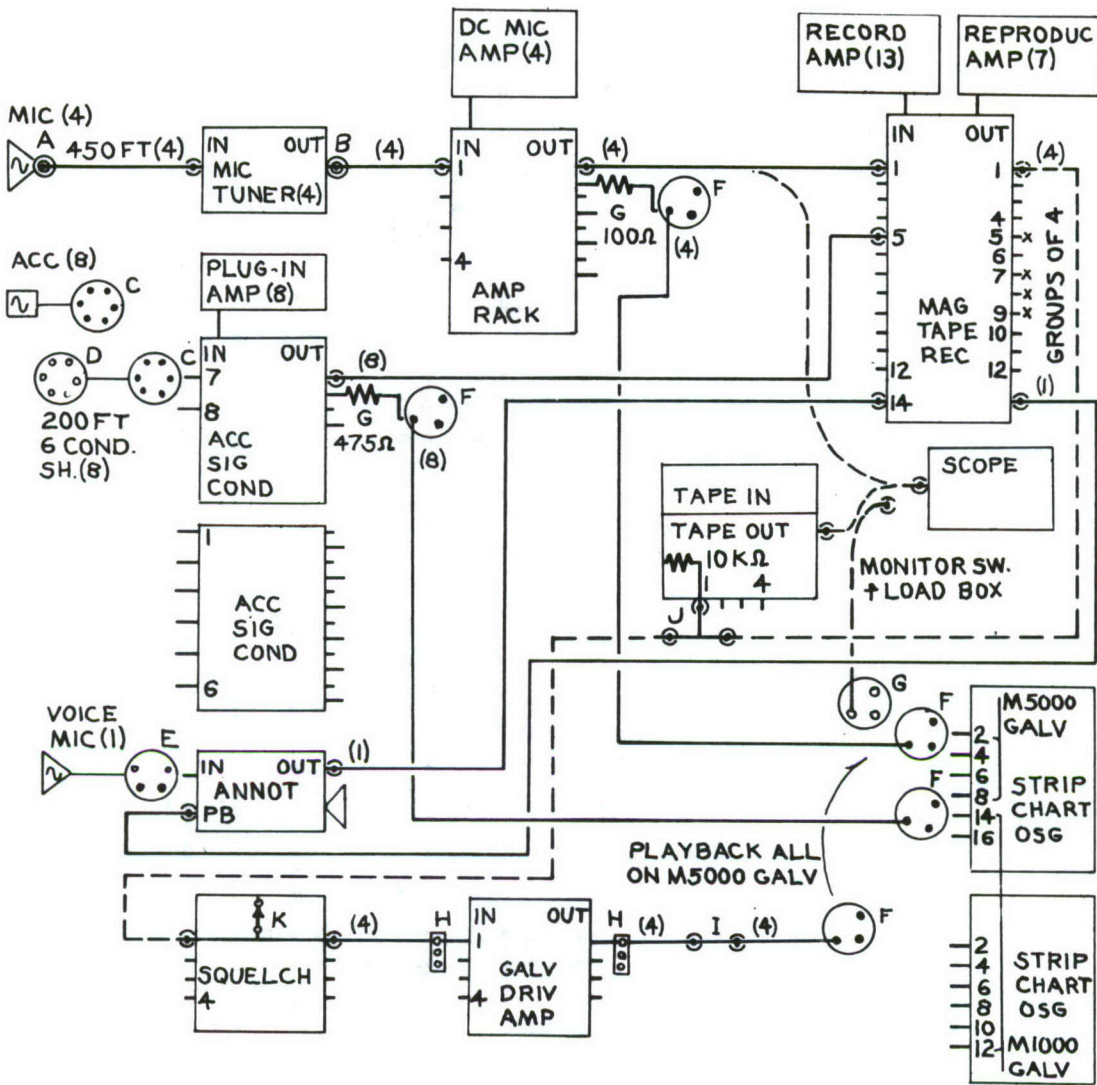

Figure 21.--Accelerations of shed 4 by simulated Boom 1, Chart speed 31.5 inches/second.

APPENDIX I, FIGURE 22



- A. MODIFIED BNC
- B. MS3106A-8S-1PP
- C. -14S-6P 2211
- D. MS3101A-14S-6S(C)
- E. XLR-4-12C
- F. XLR-3-11C
- G. XLR-3 EXTENSION SOCKET
- H. Q3P
- I. J-J COUPLING
- J. J-P-J TEE
- K. CLOSED WHEN TAPE POWER ON,  
DRIVE OFF.

EXCEPT AS NOTED, CONNECTORS ARE BNC, CABLES ARE RG58 C/U. ALL CABLES SHIELDED, BOTH ENDS GROUNDED, EXCEPT B.

APPENDIX I, FIG. 22  
SIGNAL CONNECTIONS  
NASA-USDA INSTRUMENT SYSTEM  
FOR SONIC BOOM OVERPRESSURE +  
STRUCTURAL ACCELERATION.  
J.R. MENEAR - AERD, ARS, USDA AT  
SMIS, EMIB, IRD, NASA-LANGLEY  
RES. CTR. JA70

## APPENDIX 2, MECHANISM OF STRUCTURAL EFFECTS

Little information is available on the effects of sonic boom on farm structures. Studies on urban structures are not very applicable, for several reasons. The economics of farm construction usually results in structures which are relatively large, but with less mass and strength than urban structures; shape tends to be simple, with large, flat, continuous expanses of wall and roof; structures are often in isolated, exposed locations; static loads may be high relative to design strength; design is often not standard; construction details such as fitting and fastening may be less than optimum; inspection and maintenance may be inadequate. Consequently, farm structures in general must be considered more vulnerable to atmospherically induced structural motion and damage than urban structures. However, the probability of detectable superficial damage is less, because most farm structures have little brittle, decorative materials such as glass and plaster. An important exception to this is the greenhouse type of structure.

Description of any but the most gross effects of shock waves on structures is complicated by the transient and highly variable nature of the phenomena. When structures are in close groups such that shielding and reflection effects are exchanged, pressure effects become much more complex. Impulses are of such short duration that inertia of members and rheological properties of materials may be significant. Therefore, the essential characteristics of shock waves are not precisely replicable between tests. These same difficulties apply to empirical measurement, by necessitating instrumentation systems with rapid dynamic response, large numbers of sensors, and repeated tests.

The effect of an atmospheric shock wave on structures is essentially one of net pressure impulse on large surfaces such as walls and roofs. Two main processes which determine the magnitude of net pressure impulse on a surface member are pressure addition by reflection and pressure equalization in shielded spaces.

Pressure addition occurs on exposed structural surfaces in the same way as it does on the ground surface. On the reflecting surface, incident and reflected waves are in phase, and if the surface has high reflectivity, pressure there is nearly twice that of the free-field incident wave. This occurs at all wave angles from zero to near  $90^\circ$ ; at  $90^\circ$ , the wave moves parallel to the surface, and pressure is equal to that of the incident wave. The pressure acts normal to the surface in all cases.

A structural surface may be struck by both the direct incident wave and its reflection from the ground, with consequent near-doubling of each of these as they reflect from the surface; the resulting total pressure on the surface can approach four times that of the incident wave, or twice that of the ground plane measurement. At heights of

several feet above ground, the ground reflected wave is slightly out of phase with the incident wave, but with typical sonic boom waveforms this does not appreciably change the direct additive effect of maximum pressures.

Pressure addition as described here is probable for farm structures subject to a sonic boom. The only essential conditions are large flat structural surfaces and reflective surrounding ground, which are typical. Reflection effects of greater complexity such as three-dimensional focusing, which could cause even greater pressure addition, are possible but not very probable.

A simplifying concept of the sonic boom shock wave is useful as an aid to visualizing the approximate effects on structures. The wave can be considered a composite of incident and ground reflected parts, moving horizontally along the flight track at aircraft speed with a waveform with interrupted rises, and causing nearly twice its own ground plane pressure on large exposed surfaces close to the ground.

Pressure equalization is a movement of air into spaces shielded from the wave approach direction; this movement requires time, and it is only during this time that a shock wave can develop net pressure on a structure. The rate and time of equalization depend on the effective volume of the space and the rate of flow from surrounding overpressure spaces, both of which depend on the degree of shielding. The degree of shielding by a single flat surface depends on its projected area to the wave approach direction, therefore on its size and angle; the angle affects only shielding, not the overpressure on the exposed surface. Equalizing flow occurs around all edges exposed to the wave and through any openings; as a shielded space is pressurized, the spaces from which the air flows lose pressure. If a single surface is very large, the central part is essentially completely shielded because the duration of positive overpressure of the shock wave is too short for flow to reach the center. In the extreme case, a fully enclosed, rigid, airtight structure of any size has complete shielding and no equalization to the inside is possible.

Most farm structures are formed of flat surfaces joined at or near edges to other surfaces. The additional surface restricts or prevents equalizing flow at an edge, depending on whether or not the joint is closed or vented. In many cases, both of such joined surfaces are exposed to the wave, for example, a sidewall and a roof slope. In other cases, such as two slopes of a peaked roof, only one may be exposed, but the other contributes to the shielding effect by enlarging the shielded space in depth and restricting equalizing flow to the underside of the roof. The shielded slope is shielded on both surfaces; however, the shielded space on the upper surface is relatively shallow and is equalized quickly, while that under the roof is larger and more shielded, and so is equalized more slowly. Therefore for a time pressure is greater on the upper surface of the shielded slope.

Determination of force and force impulse on a particular member, which are significant quantities in structural studies, would require integration of net pressures over time and the surface dimensions. Figure 17 illustrates a possible time variation of pressure, and its associated pressure impulse, at one point on a surface subject to sonic boom shock wave. This can also be considered to illustrate a variation of force, and associated force impulse, on a member. An arbitrary rate of equalization has been assumed in this Figure, such that it occurs only slightly during the rapid rises but is completed well within the duration between rises. This results in net pressure being positive, that is inward on the structure, after both rises. It reaches a peak simultaneously with gross pressure on the exposed surface and thereafter tends toward zero. If the equalization rate were high, little or no net pressure would occur; if it were quite low, net pressure would be nearly equal to gross pressure throughout the wave traverse.

Neither force nor force impulse is a complete measure of shock loading intensity. Force is not adequate when the time of action is so short that the inertial resistance of structural members restricts elastic deflection; impulse is not adequate because a given quantity can result from a negligible force over time. The most effective time distribution of a given quantity of impulse for deflecting an elastic structure would be that in which force increased to a maximum at the end of its duration. The impulse of a sonic boom shock wave is not distributed in this way but rather tends to reach maximum force near the start of its duration. The first part of the impulse, including the force maximum, tends to be spent in overcoming inertial resistance to deflection; but with deflection, elastic restoring force increases and continued deflection requires even greater applied force. Structural deflection is thus limited by the magnitude of applied force, although the applied impulse may continue. The implication here is that the effective impulse of a shock wave for structural deflection may be limited to that part which precedes maximum net pressure. This is only a fraction of net impulse such as illustrated in Figure 23, and a much smaller fraction of gross positive impulse defined by the sonic boom waveform.

The net impulse applied to the structure causes the typical reaction to loading by atmospheric shock wave: Surface members are deflected, with accelerations determined by the instantaneous resultants of forces due to pressure, inertial resistance of members, rigidity of supports, and gravity. Force reaction through the supports causes some deflection of the entire structure. As the impulse passes, restoring forces caused by the elasticity of supports tend to reverse the deflections and induce structural vibrations of members and of the entire structure, each at its natural frequency. The second rapid rise of an N wave repeats the process and may cause greater deflections if its maximum force happens to coincide additively with the elastic restoring forces.

In some respects, the effects of an atmospheric shock wave on structural surfaces are similar to those of turbulent winds. Both can cause rapid pressure changes and consequent net pressure differences between exposed and shielded spaces. However, there is a basic difference in that a shock wave is a sharply defined zone of pressure gradient moving several times as fast as wind, while wind is a coherent mass movement of air at ambient pressure. Although a shock wave is a highly transient phenomenon, its pressure is essentially static and acts in all directions, while that of wind depends on the direction of air movement. A shock wave is reflected from a surface placed at an angle to its motion, with consequent doubling of pressure on the surface. This effect occurs at all angles except near zero, where the surface receives only the pressure of the wave. In all cases, the pressure acts normal to the surface. Wind, on the other hand, is deflected from a surface, and the normal pressure developed increases with the angle. There is also tangential pressure because of friction in the direction of air movement across the surface. Wind can cause negative pressure in shielded spaces, while a shock wave can not.

Although the pressure of a shock wave is not directional, the orientation of a structure to the wave approach direction is an important determinant of pressure effects. One such effect involves the pressure gradient in the length of a typical N wave, which is about the same length as typical farm structure dimensions. This can be illustrated with the example of a long, narrow structure with a peaked roof such as in the present test. If it is oriented in the horizontal plane normal to the approach direction, the entire length receives the instantaneous pressure of the wave simultaneously. Also, that orientation maximizes projected area normal to the approach direction and the degree of shielding, maximizing force and force impulse on the structure. The boomward roof slope receives incident pressure above, while its underside is shielded. The leeward slope is shielded above and below. If there are no walls, the lower, as well as the upper, surface will receive some pressure by equalizing flow as shown in Figure 24. At the other extreme, if the structure is aligned with the wave direction, it is swept lengthwise by the pressure gradient, with different pressures along the length at any instant. In the special case of a structure with no end wall and little obstruction inside, the wave sweeps under as well as over the roof, and net pressure on the roof is zero.

If such an unwallled structure is oriented obliquely to the wave direction, another effect occurs at the exposed end. The wave enters the open end and contacts part of the underside of the leeward roof slope, the outside of which is shielded, thus causing a net outward pressure and impulse on it. Horizontal components of the impulses on both roof slopes add to cause transverse racking forces at that end of the structure greater than elsewhere.

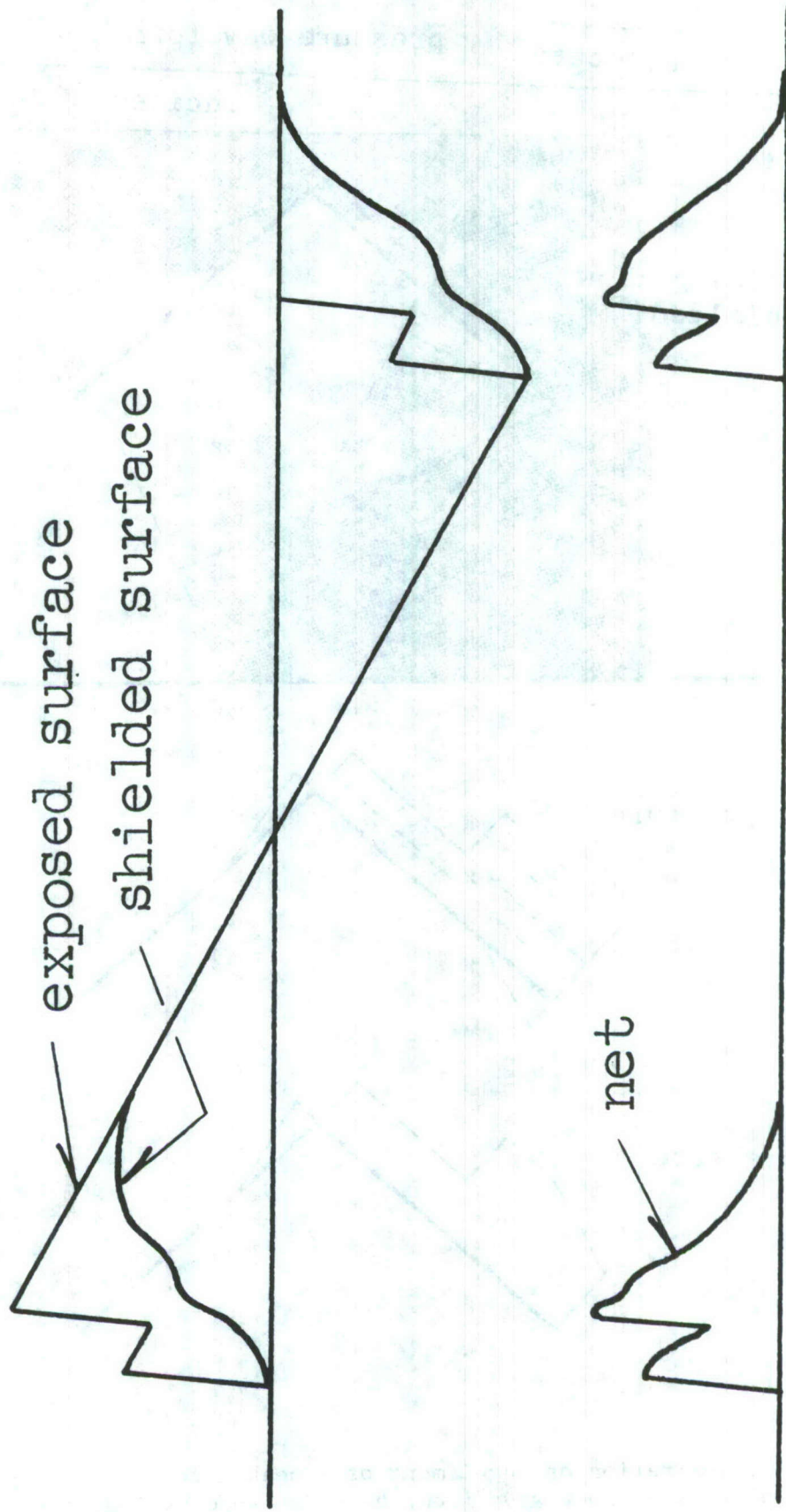

Figure 23. -- Illustration of pressure impulse on a structural surface member as affected by an arbitrary rate of pressure equalization.

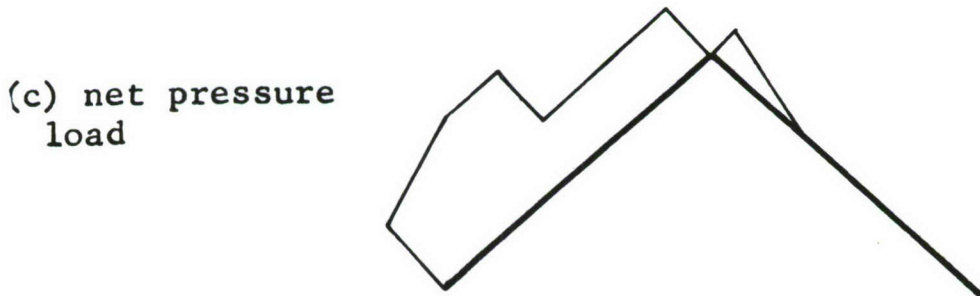
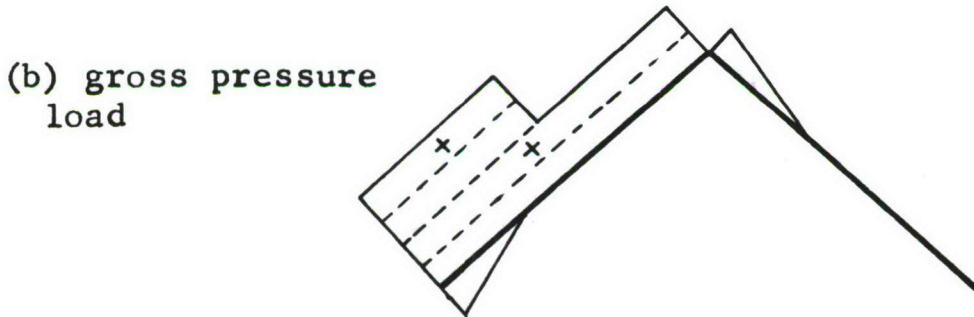
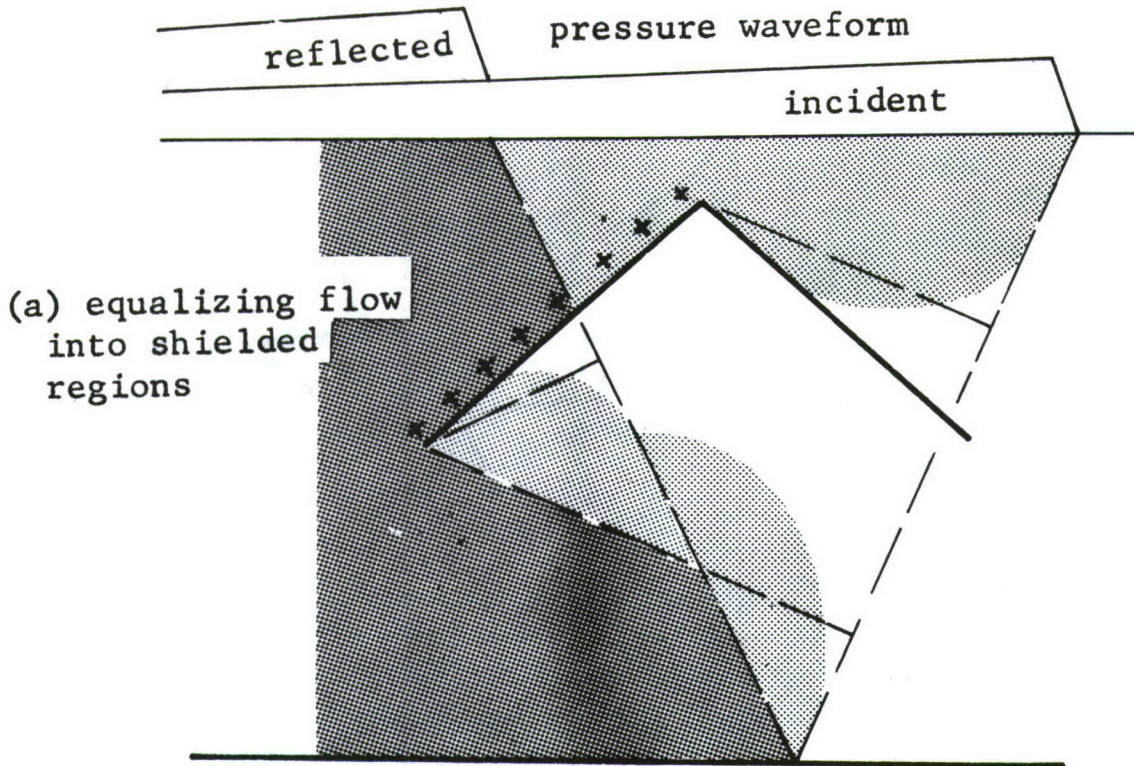

Figure 24.--Illustration of engulfment of a peaked roof structure without walls by a shock wave from the side; shading indicates overpressure; (+) indicates pressure doubling by reflection.

The Behavioral Response of Female Mink Exposed  
to Real or Simulated Sonic Booms

Charles R. Curran<sup>1,2/</sup>

INTRODUCTION

Broadly defined, a sonic boom is an intense auditory stimulus of short duration that is usually not preceded by any warning stimuli. Much of the research aimed at an analysis of the behavioral and physiological consequences of such brief, intense sounds has dealt primarily with the startle response occurring within the first few seconds after a sudden acoustic stimulus. Although there is little agreement on a standard method for reliably measuring startle, it is generally agreed that startle consists of a gross muscular reaction occurring immediately after an unexpected noise that is accompanied by other transitory physiological changes, such as quickening of heart and respiration rates, and changes in stomach motility (Morgan and Olmstead, 1939; Jones and Kennedy, 1951; Sternback, 1960).

Research on the behavioral properties of startle have shown that, in the case of rats (Hoffman and Searle, 1967), repeated exposure results in a rapid weakening of the startle response, although for intense noises the response does not completely disappear even after 675 exposures over an 11-day period. Moyer (1963) found rapid habituation with as few as five successive pistol shots separated by 30 seconds. In both studies, partial recovery occurred at the beginning of each day's trials. Hoffman and Searle (1967) also reported that, for rats, the occurrence of acoustic startle appears to be dependent upon the intensity of the noise and not upon its frequency characteristics. Recovery from the startle reaction appeared to occur within seconds after the acoustic stimulus. Similar results have been reported for swine by Winchester, et al. (1959) and by Bond, et al. (1963).

Pallen (1944) and Hartsough (1968) have suggested that unusual noises or other disturbances to which female mink are unaccustomed may cause them to inadvertently kill some or all of their kits. These authors thus suggest that the effects of intense noises may persist beyond the first few seconds in which startle is likely to occur. Lawsuits filed by mink ranchers (Grubb, et al., 1967) have asserted that long-term changes in the behavior of the mink do, in fact, occur and result in such phenomena as cannibalism, kit killing, burying kits in the nesting material, and a cessation of lactation resulting in kit starvation.

Unfortunately, laboratory studies of the behavioral and physiological responses of mink to unexpected, loud noises have not been reported. However, on-site observations of the effects of simulated sonic booms on

---

1/ Captain, U.S. Air Force, Armed Forces Radiobiology Research Institute, Defense Atomic Support Agency, Bethesda, Maryland 20014.

2/ The views expressed herein are those of the author and do not necessarily reflect the views of the U.S. Air Force or the Department of Defense.

farm-raised mink have been conducted by Travis, et al. (1968). This study concentrated on long-term measures of simulated boom effects such as kit survival and health of the females and their kits. Observations of the mink immediately after each boom were limited to assessment of general farm reaction. On this basis, exposure to simulated sonic booms appeared to have little overt effect on the farm activity level. A few animals came out of their nest boxes or looked out of their cages. There was no evidence of the kind of agitated activity or warning screeches which would have been indicative of continued arousal. Reproduction in both the boomed and not boomed groups were considered normal.

The objective of this phase of Project Cool Mink is to inspect the behavior of individual farm-raised female mink before and after real and simulated sonic booms to determine the nature and temporal duration of any observable behavior changes during whelping season which could be related to sonic boom exposure.

#### METHOD

Sonic Boom Test Site. Forty female mink housed in the outside rows of the mink sheds were selected as a sample of the total population for visual observation. The sample was obtained by spacing observers along the two sides of the blind facing the sheds. The four mink directly in front of an observer location automatically became part of the sample. Cage numbers of the mink under observation may be found in Table 1.

Ten members of the Project Cool Mink staff served as official observers. These observers were present for all baseline and sonic boom observation periods and monitored the same four animals on all test days. Other members of the Project staff also observed the activity within the mink sheds when their primary duties permitted. However, their observations entered into the general assessment of ranch activity and were not included in the analysis of individual animal behavior. The animals observed by these staff members are listed separately in Table 1. The location of each observer is identified in Figure 4 of the Physical Environment and Boom Effects section. Background information on each observer may be found in Appendix I.

Before arrival at the test site, all observers were extensively briefed on the procedure to be used in recording descriptions of mink activity. Similar briefings were also held after the first two baseline observation periods to insure standardization of procedures between observers. The observers were instructed to record a running description of each animal's ongoing activity, the cage number of the mink whose activity was observed, and the time at which the observations were made. For purposes of definition, the nest was considered only the wooden box in which the female constructed her straw nest, while the wire enclosure in which she ate, eliminated, and exercised was called her cage. With

TABLE 1.--Cage Number of Animals Under Observation

Sonic Boom Test Site		Simulated Sonic Boom Test Site	
Animals Observed on All Days		Animals Observed on Baseline and Test Day	
333	495	295	311
334	496	296	312
335	497	297	313
336	498	298	314
341	499	299	315
342	500	300	316
343	501	301	317
344	502	302	318
357	503	303	TV Monitor was Placed Above the Nest Box Containing Female 314.
358	504	304	
359	505	305	
360	506	306	
483	507		
484	508		
485	509		
486	510		
487	515		
488	516		
489	517		
490	518		
Animals Observed On Boom Day Only			
347	367		
348	368		
349	511		
350	512		
351	513		
352	514		
353			
365	TV Monitor was Placed Above the Nest Box Containing Female 370		
366			

the exception of one female whose nest was exposed to a TV monitor, reliable observation of ongoing activity could only be made while a female was in her cage. A record was also made of the time and origin of all noises, such as those made by vehicles passing on the nearby road, by the mink, or by mink caretakers in the sheds. Each observer was provided with a portable tape recorder and sufficient magnetic tape to record and permanently store the results of all observation periods.

Three days of baseline observation began 4 days before actual sonic boom exposure (see Figure 1). The mink were under observation for 3 hours each day from 1000 to 1300 hours (1 hour before the first planned sonic boom to 1 hour after the last boom).

The procedure for observing the mink on the day of sonic boom exposure was identical to that employed during baseline observations. However, the observation period was extended by one-half hour to permit recording the animal's activity following a distant road-building blast. Observers were also placed at the simulator site and the control site to record the reaction of the mink at these locations, should the noise of the aircraft reach them. Follow-up observations were made at the sonic boom test site on the day after sonic boom exposure for the same 3-hour period.

A closed-circuit TV monitor was positioned above the nest box of one female with a litter on the day of the sonic booms. The camera continuously monitored the activity of the female mink and her kits inside their nest for 3 minutes before and 15 minutes after each sonic boom.

The observer's taped observations were later transferred to data sheets for analysis. These data sheets were used to compute the frequency of occurrence of significant behavioral units within successive 5- or 15-minute intervals.

Simulator Test Site. The same procedure was also used to observe the activity of the females housed at the simulated sonic boom test site. Twenty females distributed along the shed facing the blind were selected for observation. The cage numbers of the observed animals appear in Table 1. Baseline observations (see Figure 1) were limited to the day preceding exposure to simulated sonic booms. A TV monitor was positioned above one female with a litter, and her nest was monitored 3 minutes before and 15 minutes after each sonic boom. The data from the animals exposed to simulated booms were also transferred to data sheets for analysis.

## RESULTS

Sonic Boom Test Site. A group summary of the baseline activity at the sonic boom test site on 9 May 1970 may be found in Table 2 (baseline observations from 7 May 1970 and 8 May 1970 appear in Appendix II). On

TABLE 2.--Group Baseline Activity Summary for 9 May 1970

Event	End of time interval												
	1014	1029	1044	1059	1114	1129	1144	1159	1214	1229	1244	1259	
Peer from nest	9	10	14	14	8	15	11	13	15	13	13	8	10
Enter cage	20	18	12	18	15	19	18	17	14	13	12	12	13
Enter nest	22	20	13	16	16	19	19	20	14	15	12	12	14
Drink	12	9	5	13	5	3	11	1	4	7	1	1	2
Scratch with feet	4	3	10	10	6	6	9	2	5	5	7	7	3
Scratch on cage	2	4	7	8	11	9	12	6	4	7	2	2	3
Move about cage	7	8	6	12	8	18	11	6	10	8	6	6	6
Transport bedding	2	1	2	1	1	3	7	4	1				1
Chew bedding	4	1	1	1	2	3	5					2	1
Urinate	3	2	3	2	1	3	2	2	3	1	2	2	1
Defecate	6	3	5	6	2	4	4	5	5	3	3	3	4
Sniff food	2	1		3	2	1		4	1	2	2	2	1
Eat	5	2	6	4	7	7	1	5	3	2	2	2	2
Groom	2	2	4	3	6	6	4	2	2	3	1	1	1
Pace	9	9	1	3	1		3	3	2	1			
Peer into nest	3	1		3	1	1	3	3	2	5	1	1	1
Lie in cage		2		2	1	5	3	1	2	3	2	2	3
Alert toward noise							2	2					
Watch other mink		4					1	1		1	1		1
Shake	2	1	2	3	4	4	13	1	3	1	3		1
Yawn and stretch		1		1	1	2	1		2				
Vomiting				1									
Gnaw wire	1											1	
Look out of cage			2						1				1
Climb wire	2	4	2					3					
Total	117	106	95	124	96	125	137	100	91	88	67	67	67

N = 40 females.

11 May, the sonic booms occurred at 1058, 1144, and 1159. The number of times the animals as a group performed the listed activities is summed within successive 15-minute intervals. For most categories listed, the frequency of occurrence is fairly evenly distributed across time. The categories with the highest frequencies include peering from the nest, entering the cage, entering the nest, moving about the cage, drinking, and defecating.

Table 3 presents the group activity summary for the sonic boom test day. Except for the intervals containing the sonic booms, the frequencies of most categories are similar to those reported on 9 May. Immediately after the first sonic boom, there was a sharp increase in the number of observations of peering from the nest, entering the cage, entering the nest, drinking, moving about the cage, and defecating. The total frequency for the interval ending at 1059 (time interval in which the first sonic boom occurred) was also more than double the frequencies of the 1044 or 1114 intervals bordering it. Since the second sonic boom occurred at 1144, the elevated activity level appears to continue into the time interval ending at 1159. After the second boom, a moderate increase in the frequency of peering from the nest as well as a slight increase in several other categories resulted in higher totals for these time intervals. The frequencies in the 1214 interval indicate that, after the 1200 boom, there was a slight rise in activity, although no single category showed a large increase over baseline levels. Activity levels increased sharply again at 1230, most likely as a result of the presence of the caretakers in the sheds counting kits in preselected nest boxes.

Similar frequency distributions are presented in Tables 4 and 5, using successive 5-minute intervals for the 90 minutes containing the sonic booms. These distributions present separately the frequencies for pregnant females and females with kits. There appear to be no significant differences between pregnant females and females with kits, either in their general activity levels before and after sonic boom exposure or in the kinds of activities (except transporting kits) observed.

Table 6 presents the frequency distribution in successive 5-minute intervals for all 40 females during the 30 minutes in which the road-building blast occurred. Immediately after the blast, there was a slight increase in the number of animals peering briefly from their nests. The most significant influence on general activity levels, however, appeared to be the continued presence of the caretakers in the sheds.

Table 7 summarizes the activity of all observed females for 1 minute immediately following each sonic boom. This summary was derived from Appendix III, which lists the activity of each female

TABLE 3.--Group Activity Summary for Sonic Boom Exposure Day, 11 May 1970

Event	End of time interval											
	1014	1029	1044	1059	1114	1129	1144	1159	1214	1229	1244	1259
Peer from nest	12	20	20	49	14	6	35	20	17	16	44	24
Enter cage	18	19	16	38	23	9	8	13	9	11	43	27
Enter nest	14	24	13	40	22	10	6	10	10	10	42	27
Drink	9	5	6	14	7	2	3	10	3	6	4	2
Scratch with feet	7	5	9	13	4	2	3	6	6	3	7	14
Scratch on cage	4	1		7	3	3	4	9	7	2	2	9
Move about cage	5	9	6	14	5	6		5	3	4	7	14
Transport bedding	1	3	1	5	6	1	2	3	4	1	1	1
Chew bedding	1	3	2		2		1					
Urinate	2	1	1	3	2	3		4	3	1	2	1
Defecate	1	2	1	9	2	2		5	1	2	2	3
Sniff food	3	2	1	1	2	1		2	2	1	1	3
Eat	5	1	8	3	2	1		2	3	5	3	7
Groom	3			2	3	1	3	4	7	2		2
Pace												
Peer into nest	1		7	8	1	1		1	1	3	1	3
Lie in cage					1	2		1		2	1	2
Alert toward noise		1					1				4	1
Watch other mink		4										4
Shake		2	1	4				1				1
Yawn and stretch		2	1		5							4
Climb wire	1	2	2	1			5	1			1	
Remove kit from nest		1		1				1				
Retrieve kit to nest		1	1	1				1				
Look out of cage	2	2	1	2				2				
Gnaw wire		1						1				
Startle		1					1					
Total	91	111	96	220	104	50	72	103	77	69	165	148

N = 40 females.

TABLE 4.---Group Activity Summary for Females with Kits on Sonic Boom Exposure Day, 11 May 1970

Event	End of time interval																	
	1049	1054	1059	1104	1109	1114	1119	1124	1129	1134	1139	1144	1149	1154	1159	1204	1209	1214
Peer from nest	4	3	16	4	3	3	1	2	1	1	1	10	3	5	9	4	2	
Enter cage	6	4	8	9	3	1	1	1	5	1	1	1	4	1	1	2	2	1
Enter nest	8	4	7	6	4	2	2	1	4	1	1	1	4	1	2	3	1	1
Drink	6		3	3	1				2	2			1	2				1
Scratch with feet	2	1	2	2	1			1		1			1	1	1	1		1
Scratch on cage	4	1	4	1	1		1		1	1			1	1	1	2		
Move about cage	4	1	4	1	1		1		3	1			1	1	1	2		
Transport bedding	2		1	2	2	1		1	1				2			2		
Chew bedding				1	1		1		1				1	1	1			1
Urinate	1		1	1					1				1	1	1			1
Defecate	1		4	1	1				1				1		1			1
Sniff food	1			1		1			1							1		
Eat	1	1		1		1			1							1		
Groom			1	1	1		1											
Peer into nest	3		3						1					1				
Lie in cage				1														
Alert toward noise									1									
Carry kit into cage	1												1					
Carry kit into nest	1												1					1
Shake	3			2	1									1				
Yawn and stretch															1			
Climb cage wire	1																	
Total	45	15	54	36	18	9	8	5	22	8	1	12	21	15	17	18	3	5

N = 14 females.

TABLE 5.--Group Activity Summary for Pregnant Females on Sonic Boom Exposure Day, 11 May 1970

Event	End of time interval																	
	1049	1054	1059	1104	1109	1114	1119	1124	1129	1134	1139	1144	1149	1154	1159	1204	1209	1214
Peer from nest	2	2	22	1	3	1	1	1	1	1	3	19	1		2	7	1	3
Enter cage	6	7	7	6	2	2	2				2	4	2	2	3	2	2	2
Enter nest	7	7	7	6	2	2	2	1			2	2	1	1	3	3	2	1
Drink	1	2	2	2	1		2				1	1	1	1	3			3
Scratch with feet	4	2	2	1			2				1	1	1	2	2	3	1	1
Scratch on cage	2	2	2	2			2	1			2	1	1	2	3	2	1	3
Move about cage	1	2	2	3		2					1	1	1	1	1			1
Transport bedding	1	2	2		1							1	1		1	1		1
Urinate			1	1		1		1							1			1
Defecate	1	1	2	1			1	1					1	1	1			1
Sniff food				1									1	1	1			1
Eat	1													1	1			2
Groom			1	2										1	1			2
Peer into nest		1	1	1							2	1	1	1	2	3	1	2
Lie in cage								1							1			
Shake			1	2										1	1			
Yawn and stretch	1	1	3							1	4			1	1			1
Climb cage wire																		
Look out of cage	1														1			
Gnaw wire														1				
Startle												1						
Total	27	27	51	27	6	8	9	4	2	2	17	31	10	14	26	21	9	22

N = 26 females.

TABLE 6.--Group Activity Summary For Road-Building Blast

Event	End of time interval					
	1304	1309	1314	1319	1324	1329
Peer From Nest	11	10	6	13	16	6
Enter Cage	2	6	5	8	6	2
Enter Nest	3	2	10	8	4	5
Drink	3	2	5	4	3	1
Scratch With Feet		3	5	6	5	
Scratch On Cage		1	1	2	4	
Move About Cage		4	4	4	6	1
Transport Bedding	1	1	1	1		
Chew Bedding	1					
Urinate		2	2	2	2	
Defecate	1	1	2	3	1	
Sniff Food		1	2		1	1
Eat		3	6	1	4	6
Groom	1	1	1	3	3	
Pace						2
Peer Into Nest			2		1	1
Lie In Cage	1	1		1	1	
Watch Other Mink		1	1	2	4	
Shake		1	4	1	1	
Yawn and Stretch	3	2				
Climb Cage Wire		2	1	1	1	
Retrieve Kit	1					
Total	28	44	58	60	63	25

N = 40 females.

TABLE 7.--Observed Activity Summary For 1 Minute Post-Sonic Boom

	Not Visible	Peer From Nest	Enter Nest	Enter Cage	Peer Into Nest	Move About Cage	Continue Activity	Groom	Scratch	Pace	Defecate	Startle	Total Visible Activity
1058 - 1059	5	44	7	8	1	3	1	2	3	1	2	1	73
1144 - 1145	19	30					1						31
1200 - 1201	33	14	2	3		1					1		21

for the first minute postsonic boom. The table clearly shows that the general activity level of the observed mink decreased with successive sonic boom exposure, even with as few as three booms.

Follow-up observations the day after the sonic booms suggested that the activity within the sheds remained at preboom levels. Observations were limited to only 12 females and a general overview of the sheds during the 3-hour period. A frequency distribution in 15-minute intervals for 12 May can be found in Appendix IV.

A table of background noises appears in Appendix V. The activity of each animal was inspected at the time of each listed noise. For the vast majority of the noises, no changes in behavior were noted. Excluding the sonic booms and road-building blast, only two noises appeared to have any overt influence on the behavior of specific animals. During a test of the two-way radio at 1026 on 8 May, one animal (eating at the time) rushed into her nest immediately after a high-pitched signal of short duration, quickly returned to the cage, and resumed eating. On 11 May, a brief, high-pitched noise made inadvertently by a TV cameraman resulted in two animals rushing into their nest and immediately peering out. In both cases, all other animals in their cages at the time of the noises appeared to continue ongoing activity. Noises which the animals heard on a regular basis, such as passing vehicles, single-engine light aircraft, and the barking of a caretaker's dog, produced no overt changes in behavior.

Observers stationed at the mink control site and the simulated sonic boom site on 11 May reported that the sonic booms were not heard at these locations, although they were able to hear distant sounds of jet aircraft. The mink at both locations exhibited no overt response to the aircraft sounds.

Tables 8 and 9 present the recorded activity of two females for the last baseline day and sonic boom exposure. These animals were chosen as most representative of the females under observation in terms of the activity levels recorded for a 3-hour period. Animal 335 was still pregnant when boomed. Animal 357 whelped before 1000 hours on 9 May. In these tables, a space is used to denote time spent by a female in the nest box where her activity could not be reliably observed. The time indicated for each unit of activity represents the time of onset. Although the exact amount of time spent engaged in each activity cannot be precisely determined from this table, a rough estimate can be made by determining the elapsed time between the onset of the unit of interest and the onset of the next unit. Eating, for example, often persisted for several minutes, while drinking rarely took more than a few seconds. Animals 335 and 357 were inside their nests at the time of each sonic boom. Both peered from the opening of their nest boxes

TABLE 8.--Activity Record of Mink 357 For 9 May 1970 and 11 May 1970

Female 357 - Whelped 5/9/70 5/9/70 Baseline	5/11/70 Test Day
1005 - Head out of nest box chewing bedding material	1015 - Peers from nest
1009 - Transport bedding around cage	1017 - Enters nest
1010 - Chews bedding material	1017 - Eats
1010 - Enters cage	1019 - Enters nest
1010 - Eats	
1010 - Peers into nest	1021 - Drinks without leaving nest
1010 - Shakes	
1010 - Eats	1031 - Peers from nest
1011 - Enters nest	1032 - Leans out of nest and eats
	1033 - Enters cage
1052 - Peers out of nest	1033 - Eats
	1034 - Enters nest
1126 - Enters cage	
1126 - Shakes	1049 - Peers from nest
1126 - Moves to cage front	1050 - Drinks without leaving nest
1126 - Defecates	
1126 - Urinates	1058 - Peers out of nest after sonic boom
1126 - Shakes	
1126 - Climbs cage side and eats	1100 - Peers from nest
1128 - Drinks	
1128 - Shakes	1104 - Enters cage
1128 - Wanders about cage bottom	1104 - Scratches with hind feet
1128 - Climbs cage side	1104 - Urinates
1128 - Moves to cage front	1104 - Defecates, scrubs bottom on cage floor
1128 - Scratches on side of cage	1104 - Drinks
1129 - Enters nest	1105 - Shakes
	1105 - Enters nest
1131 - Peers out of nest	1105 - Backs into cage
	1105 - Shakes
1134 - Drinks without leaving nest	1105 - Chews bedding material
1134 - Chews bedding in front of nest	1105 - Enters nest
1134 - Enters cage	
1134 - Moves along cage side	1110 - Enters cage
1134 - Climbs side of cage	1110 - Scratch with hind feet
1135 - Wanders about cage bottom	1110 - Shake
1135 - Shakes	1111 - Enters nest
1135 - Wanders about cage bottom	
1135 - Defecates, scrubs bottom on cage floor	1114 - Leans out of nest and pulls bedding in
	1114 - Enters cage
1136 - Shakes	1114 - Eats
1136 - Enters nest	1116 - Enters nest
1203 - Peers from nest	1131 - Peers from nest, rests head on opening
1203 - Enters cage	1138 - Pulls head back into box
1203 - Eats	
1205 - Wanders about cage bottom	1144 - Peers from nest after sonic boom
1205 - Shakes	
1205 - Enters nest	1158 - Drinks without leaving nest
	1200 - Sonic Boom; not observable in nest

Cont'd

5/9/70 - Cont'd.

Female 357

5/11/70 - Cont'd.

1226 - Drinks without leaving nest  
1226 - Peers from nest

1229 - Drinks without leaving nest  
1229 - Enters cage  
1229 - Eats  
1231 - Shakes  
1231 - Enters nest

1250 - Peers from nest

1207 - Peers out of nest, turns upside down and rests in that position  
1215 - Moves head into nest after noise made by cameraman  
1229 - Peers out of nest  
1233 - Leans out of nest briefly  
1238 - Peers from nest as caretakers approach  
1238 - Enters cage  
1238 - Enters nest  
1238 - In and out of nest several times as caretakers check her nest  
1242 - Moves nesting material out of box  
1244 - Peers from nest  
1245 - Enters cage  
1245 - Enters nest  
1247 - Peers from nest  
1248 - Peers from nest  
1249 - Enters cage as caretakers pass by  
1249 - Enters nest  
1250 - Peers from nest  
1254 - Peers from nest  
1257 - Enters cage  
1257 - Eats  
1258 - Enters nest  
1311 - Enters cage  
1311 - Eats  
1313 - Enters nest  
1317 - Drinks without leaving nest  
1322 - Peers out of nest after road-building blast  
1324 - Sleeping with head out of nest  
1330 - Still sleeping with head out of nest

TABLE 9.--Activity Record of Mink 335 For 9 May 1970 and 11 May 1970

Female 335

5/9/70 Baseline	5/11/70 Test Day
1032 - Enters Cage	1005 - Enters Cage
1032 - Scratches with hind feet	1005 - Scratches with hind feet
1033 - Sniffs Cage Bottom	1006 - Urinates
1033 - Urinates	1006 - Defecates
1033 - Defecates	1006 - Scratches back on cage bottom
1034 - Scratches back on cage bottom	1007 - Eats
1035 - Scratches with hind feet	1007 - Peers out of cage back
1036 - Re-enters nest box	1007 - Grooms
1039 - Enters Cage	1009 - Drinks
1039 - Scratches with hind feet	1009 - Enters nest
1041 - Drinks	1009 - Enters cage
1041 - Grooms stomach	1009 - Scratches with hind legs
1043 - Eats	1010 - Sniffs at food on cage top
1046 - Drinks	1011 - Wanders about cage bottom
1047 - Scratches chin on cage bottom	1011 - Drinks
1048 - Peers into nest box	1011 - Enters nest
1048 - Enters nest	1012 - Peers from nest
	1012 - Drinks without leaving nest
1118 - Peers from nest box	1012 - Enters cage
1118 - Enters cage	1012 - Eats
1118 - Scratches with hind feet	1014 - Drinks
1119 - Looks for food on cage top	1015 - Enters nest
1119 - Scratches chin on cage bottom	1015 - Peers from nest
1119 - Grooms stomach	
1120 - Scratches with hind feet	1038 - Enters cage
1121 - Wanders around cage bottom	1038 - Scratches with hind feet
1121 - Eats	1039 - Enters nest
1129 - Scratches chin on cage bottom	
1130 - Scratches back on cage bottom	1044 - Enters cage
1130 - Eats	1044 - Scratches with hind feet
1130 - Enters nest	1046 - Enters nest
1130 - Peers from nest	1046 - Enters cage
1130 - Enters cage	1046 - Eats
1131 - Scratches with hind feet	1047 - Enters nest
1131 - Scratches chin on cage bottom	1047 - Peers from nest
1132 - Drinks	1047 - Enters Cage
1132 - Enters nest	1048 - Peers from cage back
	1048 - Scratches with hind feet
1220 - Enters cage	1048 - Urinates
1220 - Scratches with hind feet	1048 - Wanders about cage bottom
1220 - Enters nest	sniffing
	1048 - Defecates
	1049 - Scratches chin on cage bottom
	1049 - Scratches with hind feet
	1049 - Drinks
	1050 - Enters nest

Cont'd

- 1058 - Peers from nest after sonic boom
  - 1138 - Enters cage
  - 1138 - Scratches with hind legs
  - 1139 - Grooms
  - 1139 - Scratches with hind feet
  - 1139 - Enters nest
  - 1144 - Sonic boom; not observable in nest
  - 1200 - Sonic boom; not observable in nest
  - 1231 - Rushes into cage when caretakers  
enter sheds
  - 1231 - Enters nest
  - 1232 - Enters cage
  - 1232 - Sniffs cage bottom
  - 1232 - Defecates
  - 1232 - Enters nest
  - 1306 - Peers from nest
  - 1317 - Enters cage
  - 1317 - Scratches with hind feet
  - 1318 - Urinates
  - 1318 - Defecates
  - 1318 - Enters nest
  - 1322 - Road-building blast; not observable  
in nest
-

and returned to their nests after the first boom. After the second boom, only animal 357 peered from her nest opening. Neither animal appeared at her nest opening after the third sonic boom.

At the time of each sonic boom, the animal monitored by the TV camera mounted vertically over her nest box was lying in her nest curled into almost a complete circle and nursing her kits. Immediately after each boom, this animal exhibited a clear startle response, stirred slightly, and resumed tending to her kits within 10 seconds. No attempt was made to move from her curled-up position and no attempt was made to peer from the nest hole.

Simulated Sonic Boom Test Site. The baseline activity of the 20 mink observed at the simulated boom site is summarized in Table 10. The categories with the highest frequencies include peering from the nest, entering the cage, entering the nest, drinking, moving about the cage, eating, pacing, and alerting toward a noise. The higher activity levels at the beginning of observation can probably be attributed to the presence of the observers for the first time and the fact that the animals had just been fed.

The group activity of the 20 females on the day of the simulated sonic booms is summarized in Tables 11, 12, and 13. The high levels of activity at the beginning of the observation period were influenced by the fact that the caretakers remained in the sheds until 1038, feeding animals and counting kits. The simulated booms occurred at 1110, 1154, and 1209. Table 2 suggests that general activity increased after the first boom, with the largest changes occurring in the first three categories (peering from the nest, entering the cage, and entering the nest). General activity did not appear to be affected by the second and third booms. It should be remembered that the second boom was considerably weaker than the first and third booms. The tables of activity for females with and without kits (Tables 12 and 13) indicate that the activity increased in all listed categories after each boom occurred, predominantly among pregnant females. Pregnant females were also generally more active before and after the simulated booms. Females with kits spent most of their time inside their nests.

A summary of the recorded activity of each female during the first minute after each simulated sonic boom is presented in Table 14. The lower total activity after the second simulated boom is most likely a function of the premature failure of one simulator diaphragm, causing a less intense boom. A more detailed description of the group's activity appears in Appendix III. The number of animals peering from their nest holes decreased after the second and third simulated booms.

No overt changes were observed in the behavior of the animals after the noises listed in Appendix V. These noises, including the distant rifle fire, were all of a recurring nature at the simulator test site.

TABLE 10.--Group Baseline Activity Summary For 10 May 1970--Simulator Site

Event	End of time interval											
	1014	1029	1044	1059	1114	1129	1144	1159	1214	1229	1244	1259
Peer From Nest	3	8	6	5	3	4	2	7	10	3	8	9
Enter Cage	12	17	13	9	9	8	6	7	7	9	14	15
Enter Nest	15	17	12	9	8	9	5	7	7	8	15	15
Drink	6	11	7	1	4	4		4	2	3	13	1
Scratch With Feet	4	9	4	5	7	2	2	2	3	4	10	4
Scratch On Cage	5	1	4	2	1	2	1	3	6	4	17	4
Move About Cage	15	8	6	4	7	5	7	9	5	9	16	14
Transport Bedding	2	1		1	1	3		4		3		
Chew Bedding	1	1						1		1		1
Urinate	3	1	1	3	3	2		1	3	3	2	1
Defecate	3	2	1	4	4	1		1	3	2	4	4
Sniff Food		1					1			2	1	2
Eat	4	7	3	2		1		1	1	4	8	5
Groom	3	4	1	3	3		1	3	3	3	13	3
Pace	7	8	4								1	1
Peer Into Nest									2		1	1
Lie In Cage		3	4	2	4	4	1	3	2		1	1
Alert Toward Noise	6	7	5	3	1				1	12	8	4
Watch Other Mink			3		1	2		3			4	
Shake	1	1	1		2	1		1	2	1	3	2
Yawn and Stretch					1						4	2
Chew Cage Wire	3	3	5	6	4	2	3	6	2	4	2	3
Total	93	110	80	59	63	50	29	63	59	75	145	92

N = 20 females.

TABLE 11.--Group Activity Summary For Simulated Sonic Boom Exposure Day, 12 May 1970

Event	End of time interval										
	1014	1029	1044	1059	1114	1129	1144	1159	1214	1229	1244
Peer From Nest	38	24	6	8	14	4	6	7	10	9	20
Enter Cage	17	20	20	9	16	11	11	5	8	2	16
Enter Nest	17	20	21	8	15	11	13	5	5	2	16
Drink	5	5	6	7	4	8	5	3	2	2	1
Scratch With Feet	4	6	5	7	9	9	6	3	4	2	1
Scratch On Cage	3	4	1	3	4	7	3	1	6	3	
Move About Cage	8	13	8	7	9	8	5	4	6		3
Transport Bedding		6	5	1	4	2	2				
Chew Bedding	1	1					1				
Urinate		1	3	2	2		1		1	1	1
Defecate	1	3	2	1	2	1	1		2	1	2
Sniff Food	2	1		2			1	1			
Eat		9	1	2		4	1				
Groom	2	3	3		4	4	2	3	2	1	1
Pace	5	4	7	5	3						
Peer Into Nest	3	1	1	1			1				1
Lie In Cage	3			1		3	3		1		
Alert Toward Noise		1	1	1	1						1
Watch Other Mink			3						1	1	
Shake	2	1	1	1	2			1	1	1	1
Yawn and Stretch	1		1				1			1	
Gnaw Cage Wire			1	5	1	1					
Climb Cage Wire								1	1		
Screech											1
Peer Out of Cage	6	5	8	2	6	3		1	1		4
Startle								1	1		
Total	118	128	104	73	96	76	63	36	52	26	69

N = 20 females.

TABLE 12.--Group Activity Summary For Females With Kits On Simulated Sonic Boom Exposure Day, 12 May 1970

Event	End of time interval																		
	1049	1054	1059	1104	1109	1114	1119	1124	1129	1134	1139	1144	1149	1154	1159	1204	1209	1214	1219
Peer From Nest	1				1	3								2	1	1			1
Enter Cage		2	1	1	2	2	1		1	1	2		1						
Enter Nest		2	1	2	3	2		1		1	1	1	1						
Move About Cage		3	1	1															1
Drink		3	1	1						1	1	1	1						
Scratch With Feet		2		1			1			1	2		1						
Scratch On Cage			1																
Transport Bedding			1		1	2	1	1		1									
Urinate		1	1	1					1										
Defecate		1							1	1									
Eat															1				
Groom																			1
Pace																			
Peer Into Nest	1	1	2	2	1	2	1												
Shake																			
Yawn and Stretch		1																	
Total	2	16	8	12	8	11	4	2	6	9	9	2	5	2	1	2			1

N = 8 females.

TABLE 13. ---Group Activity Summary For Pregnant Females On Simulated Sonic Boom Exposure Day, 12 May 1970

Event	End of time interval																			
	1049	1054	1059	1104	1109	1114	1119	1124	1129	1134	1139	1144	1149	1154	1159	1204	1209	1214	1219	
Peer from nest	8					5	1	1	2	2	2	2	2	2	2				2	6
Enter cage	3	3		2	2	7	6	4	4	4	3	1	2	1	1			6	2	2
Enter nest	3	1	1	2	1	5	1	6	3	6	2	2	2	1	1			3	2	2
Drink	1	2		1	1		1	5	2	1	1		1	1	1			1	1	1
Scratch with feet	2	3		2	6	6	4	2	2	2	1	1	1	1	1			4	2	2
Scratch on cage	1	1		1	3	4	4	2	1	3								5	1	1
Move about cage	1		3	2	3	3	2	4	2	4	1	1	1	2	1			4	2	1
Transport bedding						1		2	2	2								4	2	1
Chew bedding								1		1										
Urinate					1		1												1	2
Defecate					1			1						1						
Sniff food				2					1											
Eat							2	2		1				1						
Groom	1	1			1	3	2	2	1	2					2					2
Peer into nest		1	2																	
Lie in cage		1					1	1	1	1	2									
Alert toward noise		1				1														1
Watch other mink																				
Shake				1	1														1	2
Climb cage wire																			1	2
Peer out of cage		1	1	2	1	3	1												1	1
Gnaw cage wire		2	2		1			2	1										1	1
Startle	1																			1
Total	21	16	9	13	18	34	22	31	19	30	11	6	9	11	8	0	34	15	13	13

N = 12 females.

TABLE 14.--Observed Activity Summary For 1 Minute Post-Boom (Simulated)

	Not Visible	Peer From Nest	Enter Nest	Enter Cage	Peer Into Nest	Move About Cage	Continue Activity	Groom	Scratch	Pace	Defecate	Startle	Total Visible Activity
1110 - 1111	10	9	1	2		1			1				14
1154 - 1155	16	5											5
1210 - 1211	13	5		1		1						2	9

Observers stationed at the sonic boom test site and control site reported that they were unable to hear the simulated sonic booms.

The recorded activity of two females at the simulated sonic boom test site for the baseline observation day and simulated boom exposure appear in Tables 15 and 16. Animal 313 was still pregnant when boomed, while animal 300 had delivered her kits before 1000 hours on 9 May. Animal 313 was not observable inside her nest for the first two booms and was lying in the cage at the time of the third boom. After the third boom, this animal exhibited a startle response, quickly entered her nest, and then immediately returned to the cage where she sniffed the air. Animal 300 peered from her nest after all three booms. She rested her head in the nest opening after the second boom and appeared sleepy when she peered briefly from the nest after the third boom.

At the time of the first sonic boom, the animal monitored by the TV camera was pulling nesting material into her nest. Immediately after the boom, she peered briefly from the nest hole, curled into a circle around her kits, and then began to groom her own fur. This animal appeared to be sleeping at the time of the second simulated boom. She showed a clear startle response, then quickly returned to nursing her kits and nuzzling those that tried to move outside the nest formed by her body. At the time of the third boom, she appeared to be nursing her kits. After a clear startle response, she peered out of the nest hole briefly and returned to nursing her kits.

#### DISCUSSION

Baseline observations indicated that the female mink under observation in this study at the boom site and the simulated boom site spent most of the time during each of the 3-hour observation periods in their nests. Periodically, a female entered the cage to urinate, defecate, drink, eat, or engage in various other activities, such as grooming, scratching, and pacing. Each excursion into the cage generally lasted less than 4 minutes, although most animals occasionally stayed in the cage longer if they were engaged in activity such as pacing or eating. While in their nest boxes, most females were not visible except when peering from the nest opening.

Following both real sonic booms and simulated booms, the reaction of most of the female mink appeared to be brief and of little consequence to ongoing behavior. Other stimuli motivating the behavior of the mink at the time of each real or simulated boom appeared to have more enduring control over the animals' behavior than the sonic booms. Animals interrupted from activities such as eating, grooming, pacing, or caring for their young generally returned to those activities. Females inside their nests at the time of a boom either peered briefly from their nest opening, frequently sniffing the air, and then disappeared from sight into their nests or remained not visible inside their nests. The two

TABLE 15.--Activity Record of Mink 300 For 10 May 1970 and 12 May 1970

Female 300 - Whelped 5/9/70 5/10/70 Baseline	5/12/70 Test Day
1000 - Urinates	1012 - Peers from nest
1000 - Eats	
1001 - Drinks	1014 - Peers from nest
1001 - Resumes eating	
1001 - Enters nest	1100 - Enters cage
	1100 - Scratches with hind feet
	1101 - Defecates
	1101 - Urinates
1112 - Enters cage	1101 - Drinks
1112 - Drinks	1102 - Rubs back on cage side
1112 - Transports bedding into nest	1103 - Grooms
1113 - Defecates	1103 - Enters nest
1113 - Urinates	
1113 - Wanders about cage bottom	1110 - Peers from nest after simulated boom
1113 - Drinks	
1114 - Scratches with hind feet	1137 - Enters cage
1114 - Drinks	1137 - Scratches with hind feet
1115 - Enters nest	1138 - Eats
	1138 - Drinks
	1138 - Stretches and yawns
1225 - Peers from nest	1140 - Enters nest
1225 - Leans out of nest and pulls bedding material into nest	
1226 - Enters cage	1147 - Enters cage
1226 - Eats	1147 - Scratches with hind feet
1228 - Drinks	1148 - Drinks
1228 - Resumes eating	1148 - Grooms
1228 - Dashes back into cage	1148 - Enters nest
	1154 - Hangs head out of nest opening and appears to doze after boom
	1201 - Withdraws head
	1210 - Peers sleepily from nest after boom
	1232 - Peers from nest
	1238 - Enters cage - fights caretakers glove trying to re-enter nest
	1239 - Enters nest
	1240 - Enters cage

TABLE 16.--Activity Record of Mink 313 For 10 May 1970 and 12 May 1970

Animal 313	
5/10/70 Baseline	5/12/70 Test Day
1000 - Moving along back wall	1000 - Rolling and scratching with feet
1002 - Climbs to get food	1001 - Enters nest
1003 - Eats	1001 - Peers from nest
1005 - Drinks	1001 - Enters cage
1006 - Enters nest	1002 - Drinks
1007 - Pulls straw into nest	1003 - Wanders about cage bottom
1008 - Enters cage	1003 - Scratches with hind feet
1008 - Pushes straw into nest	1004 - Drinks
1010 - Enters nest	1004 - Peers into nest
	1004 - Drinks
1104 - Enters cage	1004 - Scratches back on cage bottom
1104 - Scratches with hind feet	1006 - Enters nest as caretaker approaches
1004 - Urinates	1006 - Enters cage
1004 - Defecates	1006 - Enters nest
1005 - Returns to nest	1009 - Enters cage
	1009 - Enters nest
1135 - Enters cage	1009 - Watches handlers briefly from nest hole
1136 - Scratches back on cage floor	
1138 - Moves to cage front, sniffs air	1012 - Peers from nest
1140 - Scratches back on cage floor	
1141 - Wanders about cage bottom	1020 - Enters cage
1145 - Enters nest	1020 - Scratches with hind feet
	1021 - Stretches
1159 - Enters cage	1021 - Eats
1159 - Wanders about cage bottom	1029 - Enters cage
1200 - Enters nest	1029 - Peers from nest
	1031 - Enters cage
1214 - Peers from nest, scratches head	1031 - Watches caretakers
1214 - Rolling in nest door	1031 - Enters nest
	1032 - Enters cage
1216 - Enters cage, wanders about	1032 - Watches caretaker
1218 - Sniffs food	1032 - Scratches back on cage bottom
1220 - Chews bedding material	1032 - Grooms
1220 - Urinates	1034 - Enters nest
1220 - Defecates	1034 - Enters cage, drinks
1220 - Waddles briefly	1035 - Wanders about cage bottom
1222 - Eats	1035 - Shakes
1223 - Climbs cage side briefly	1035 - Enters nest
1224 - Enters nest	1036 - Enters cage
1225 - Enters cage	1037 - Wanders about cage bottom
1225 - Wanders about cage bottom	1039 - Drinks
1226 - Transports bedding to nest hole	1039 - Pacing on cage side facing animal 312 who is also pacing
1226 - Drinks	1039 - Enters nest
1228 - Chews straw	1039 - Enters cage
1229 - Wanders about cage bottom	1039 - Climbs cage side briefly
	1039 - Enters nest
	1048 - Enters cage
	1048 - Enters nest

Cont'd

5/10/70 Cont'd

Female 313

5/12/70' Cont'd

- 
- |   |   |
|---|---|
| 1232 - Jumps in air in somersault fashion           | 1110 - Simulated sonic boom; not observable in nest   |
| 1232 - Moves bedding toward hole                    |   |
| 1232 - Peers into nest                              | 1153 - Simulated sonic boom; not observable in nest   |
| 1232 - Enters nest                                  |   |
| 1233 - Peers from nest                              |   |
|   | 1209 - Enters cage                                    |
| 1235 - Enters cage                                  | 1209 - Scratches with hind feet                       |
| 1235 - Drinks                                       | 1209 - Lying in cage bottom                           |
| 1235 - Rolls in front of nest hole                  | 1210 - Simulated sonic boom; startled response        |
| 1236 - Rubs on cage front                           | 1210 - Enters nest                                    |
| 1236 - Wanders about cage bottom                    | 1210 - Enters cage                                    |
| 1236 - Scratches back on cage bottom                | 1210 - Head up sniffing air                           |
| 1238 - Grooms                                       | 1210 - Enters nest                                    |
| 1238 - Scratches back on cage bottom                | 1210 - Peers from nest; rests head on hole until 1212 |
| 1239 - Eats   |   |
| 1240 - Enters nest                                  | 1238 - Peers from nest briefly                        |
| 1240 - Peers from nest                              |   |
| 1241 - Enters cage                                  |   |
| 1241 - Drinks                                       |   |
| 1242 - Rolls, chases tail, does somersault          |   |
| 1243 - Enters nest                                  |   |
| 1243 - Enters cage                                  |   |
| 1243 - Wanders about cage bottom                    |   |
| 1243 - Scratches back on cage bottom                |   |
| 1244 - Rolling, chases tail, does somersaults       |   |
| 1245 - Enters nest                                  |   |
| 1245 - Peers from nest                              |   |
| 1245 - Enters cage                                  |   |
| 1246 - Scurries into nest at sound of pick-up truck |   |
| 1246 - Immediately returns to cage                  |   |
| 1247 - Lying in cage front                          |   |
| 1247 - Chews bedding material                       |   |
| 1248 - Enters nest                                  |   |
|   |   |
| 1250 - Enters cage                                  |   |
| 1250 - Enters nest                                  |   |
| 1250 - Peers from nest                              |   |
-

females with kits monitored in their nests by a vertically mounted TV camera appeared to startle momentarily after most of the real or simulated booms. However, neither animal left her nest, and both continued to nurse and care for their young in the same manner observed before sonic boom exposure. Some females in their nests at the time of the booms entered their cages, briefly engaged in activities such as wandering about or drinking, and then returned to their nests. Females out in their cages at the time of a boom either rushed into their nests or briefly assumed an alert posture sniffing the air. These observations are consistent with the behavioral changes reported by Travis, et al. (1968) for female mink exposed to simulated sonic booms.

Since the startle response is of such short duration, it was not possible to make reliable visual observations of its frequency of occurrence. Where a clearly visible startle response was exhibited by one of the mink, it was recorded by the observer. However, these reports do not give an accurate indication of the frequency with which the startle response occurred in the colony. The TV and 16 mm film records suggest that most of the animals did startle to some degree after each sonic boom, although the observations of subsequent behavior indicate that the startle response of the individual animals lasted only 2 to 3 seconds. These relatively crude observations of startle suggest, however, that the startle response of female mink during whelping season is similar in duration to that reported for laboratory rats by Hoffman and Searle (1967).

The group activity distributions also suggest that, at both test sites, general activity returned to levels comparable to those observed on days of baseline observation within 5 minutes after each boom. Furthermore, the decrease in overt response to the later booms suggests that the females under observation in this study adapted or habituated quickly to recurring sonic booms not accompanied by other sensory cues to danger (e.g., visual or olfactory perception of a threat). This appears to be true even though the real sonic booms were followed by the noise of the passing aircraft. However, the aircraft noise occurring immediately after the real booms quickly decreased in intensity and consequently may have been perceived by the animals as a "receding cue" or passing threat.

The behavior of the colony exposed to real sonic booms appeared normal 24 hours later. Longitudinal data on kit survival and development appear in the reproduction and growth section of this report.

Equally important is the absence of any behavioral activity that would have suggested continued arousal or general panic within the colony. The mink did not race up and down in their cages, and there were no incidents of the kind of squealing mink are known to emit when in a high state of agitation. Moreover, females with kits were not

observed to engage in wholesale transport of their kits out of the nests, to kill their kits, or to engage in cannibalism after any of the real or simulated sonic booms. Also, the reactions of individual mink did not appear to have a consistent influence on the behavior of mink in adjacent cages. In cases where one female rushed into her nest after a boom, animals in nearby cages were observed to stop activity such as grooming for a moment, sniff the air, and resume grooming.

The females observed at the sonic boom test site were generally similar to the females observed at the simulated boom test site in terms of the kinds of behavior observed. This was true both before and after sonic boom exposure. Observed activity level differences between the two groups were not related to the effects of sonic booms. The females housed at the simulator site appeared to be more active throughout the observation periods on baseline and sonic boom test days. Another difference appeared when the animals were separated according to whether they were pregnant or had already whelped. At the simulator site, the pregnant females were considerably more active than the females with kits. However, at the sonic boom test site, there were no apparent differences in the activity levels of the pregnant and lactating females. The reasons for the inconsistency cannot be determined from the present study.

The road-building blast had little observable effect on the activity of the females at the sonic boom test site. Factors undoubtedly contributing to this finding include the previous exposure and habituation to sonic booms and the fact that the blast was considerably less intense than the booms.

#### SUMMARY AND CONCLUSIONS

The activity of arbitrarily selected female mink was observed and recorded during whelping season before and after exposure to real or simulated sonic booms. Daily observation periods lasted 3 hours and included the projected times of the real or simulated booms. Intragroup and intergroup comparisons were made in the frequency of occurrence of observable behavioral units. The results indicate that, for the mink observed in this study:

- 1) The behavioral response of the animals exposed to simulated sonic booms was similar to the response of animals exposed to real sonic booms in terms of the kinds of activity observed and the temporal duration of changes in activity levels.

- 2) The behavioral consequences of exposure to intense real or simulated sonic booms was brief in duration and had no apparent long-term effect relative to the health of the adult females or the care

and well-being of their newborn kits. Most of the animals appeared to return to preboom activities within 60 to 120 seconds after each boom. Furthermore, no panic behavior, packing of kits, or killing of kits was observed in any adult female.

3) The female mink habituated to the acoustic stimulus and vibration of sonic booms with exposure to three real or simulated booms spaced within a 1-hour time span.

#### LITERATURE CITED

1. Bond, J., Winchester, C. F., Campbell, L. E., and Webb, J. C.  
1963. Effects of loud sounds on the physiology and behavior of swine. U.S.D.A., ARS Technical Bulletin No. 1280.
2. Grubb, C. A., van Zandt, J. E., and Bookholt, J. L.  
1967. Report on data retrieval and analysis of USAF sonic boom claims files, SRI, TR-4, Contract AF49(638)-1696.
3. Hartsough, G. R.  
1968. Much still to be done in sonic boom research. American Fur Breeder. 49:21-22.
4. Hoffman, H. S., and Searle, L.  
1967. Acoustic and temporal factors in the evocation of startle. J. Acous. Soc. Amer. 43:269-282.
5. Jones, F. P. and Kennedy, J. L.  
1951. An electromyographic technique for recording the startle pattern. J. Psychol. 32:63-68.
6. Morgan, M. W. and Olmsted, J. M.  
1939. Response of the human lense to a sudden, startling stimulus. Proc. Soc. Exptl. Biol. 42:612-613.
7. Moyer, K. E.  
1963. Habituation over trials and days, and sex and strain differences. J. Comp. & Physiol. Psychol. 56:863-865.
8. Pallen, D.  
1944. Practical Mink Breeding Methods. Fur Trade Journal of Canada 8.
9. Sternbach, R. A.  
1960. A comparative analysis of autonomic responses in startle. Psychosomat. Med. 22:204-210.
10. Travis, H. F., Richardson, G. V., Menear, J. P., and Bond, J.  
1968. The effects of simulated sonic booms on reproduction and behavior of farm-raised mink. U.S.D.A., ARS 44-200.
11. Winchester, C. F., Campbell, L. E., Bond, J., and Webb, J. C.  
1959. Effects of aircraft sound on swine. WADC Technical Report, 59-200.

## APPENDICES

- I. Observer Background Information.
- II. Group Summaries of Baseline Activity on 7 May 1970 and 8 May 1970.
- III. Activity of Each Female For 1 Minute After Each Sonic Boom or Simulated Boom.
- IV. Group Summary of Activity 24 Hours After Sonic Boom Exposure.
- V. Background Noises Identified By Observers on All Observation Days.

## APPENDIX I. OBSERVER BACKGROUND INFORMATION

- Bell, Wilson B., DVM; Ph.D.; Director, University Development, VPI & SU, Blacksburg, Va., 24061; AAAS Fellow; Am. Vet. Med. Assoc.; Va. Acad. Sci.; Vet. Med. Assoc.; Conf. Res. Wrks. An. Dis.; Sigma Xi.
- Bond, James, Ph.D.; Research Animal Scientist, Animal Science Research Division, Agricultural Research Center, USDA, Beltsville, Md., 20705; Project Leader, Project Cool Mink; AAAS; Amer. Soc. An. Sci.; Society for Study of Reproduction.
- Brewer, Walter E., Lt. Col., USAF; DVM, MPH, MS, MSC; Chief, Veterinary Ecology-Toxicology Division, USAF Environmental Health Laboratory, Kelly AFB, Tex., 78241; AVMA, AHAA, Fellow American College of Veterinary Toxicology, Diplomate of the American College of Veterinary Public Health, Fellow of American Public Health Association.
- Chura, Nicholas J., Ph.D.; Research Biologist, National Park Service, Washington, D.C.; Wildlife Society; Am. Inst. of Biol. Sci.
- Curran, Charles R., Capt., USAF; Ph.D.; Principal Investigator, Armed Forces Radiobiology Research Institute, Defense Nuclear Agency, National Naval Medical Center, Bethesda, Md., 20014; AAAS, APA, Sigma Xi.
- Hinshaw, William R., DVM; Ph.D.; Chairman, National Academy of Sciences Subcommittee on Animal Response to SST-Sonic Boom; AVMA; AAAS, AIBS.
- Huttenhauer, Glenn, Lt. Col., USAF; Ph.D.; Chief, Bacteriology and Serology Branch, Epidemiology Division, USAF School of Aerospace Medicine, Brooks AFB, Tex.; Am. Soc. for Microbiology.
- Ladson, Thomas A., VMD; Director, Animal Health Department, Md. State Board of Agriculture; Head, Vet. Sci. Department, Univ. of Md., College Park, Md., 20742; AVMA.
- Leekley, James, B.S.; Biologist in Charge, Experimental Fur Station, Univ. of Alaska, Petersburg, Alaska, 99833.
- McCormick, William, Maj., USAF; LLB; Asst. Chief, Claims Division, Office of the Judge Advocate General, Headquarters, USAF, Forrestal Building, Washington, D.C., 20330.
- Robinson, Farrel R., Lt. Col., USAF; DVM; Ph.D.; Chief, Veterinary Pathology Dept., Armed Forces Institute of Pathology, Washington, D.C.; Diplomate, Amer. College of Veterinary Pathologists; Diplomate, American Board of Veterinary Toxicology; AVMA; Fellow, American College of Veterinary Toxicology.

- Stephenson, Ronald G., M.S.; Cedarburg, Wisconsin, 53012; Member, Permanent Committee on Research, National Board of Fur Farm Organizations; Member, Wisconsin Department of Agriculture Advisory Committee; Cofounder, Mink Farmers Research Foundation; Fellow, AAAS.
- Travis, Hugh F., Ph.D.; Research Animal Scientist, Director, U.S. Fur Animal Experimental Station, 324 Morrison Hall, Cornell Univ., Ithaca, New York, 41850; Assoc. Prof., Dept. Animal Sci., Cornell Univ., Am. Soc. An. Sci.; Am. Inst. of Nutrition; Committee on Fur Animal Nutrition, National Research Council; National Academy of Sciences.
- Wilson, Ruel, M.S.; Biometrician; Biometrical Services Staff, Agricultural Research Center, USDA, Beltsville, Md., 20705; Am. Soc. An. Sci.; Am. Genetic Soc.
- Wustenberg, Donald W., M.S.; Bay City, Oregon, 97107; President, Mink Ranchers Research Foundation.

APPENDIX II. GROUP SUMMARIES OF BASELINE ACTIVITY ON 7 MAY 1970 AND 8 MAY 1970

7 May 1970

Event	End of time interval											
	1014	1029	1044	1059	1114	1129	1144	1159	1214	1229	1244	1259
Peer From Nest	13	9	1	2	4	6	6	12	3	1	9	6
Enter Cage	16	18	4	13	17	17	17	6	8	6	11	12
Enter Nest	17	15	5	12	13	18	12	9	7	4	11	11
Drink	11	5	2	3	8	3	1	2	1	1	3	3
Scratch With Feet	14	9	2	5	14	8	5	4	2	3	8	8
Scratch On Cage	13	5	5		7	3	4	3	1	2	6	6
Move About Cage	18	6	3	4	6	5	3	2	2	3	6	6
Transport Bedding	5	3	1	1		2	2	2	1		1	
Chew Bedding			1				1	1				
Urinate	4	1	1	1	1	2	3	1		1	2	
Defecate	7	1	2	1	4	4	3	2	1	5	9	2
Sniff Food	3	2		1	1		8			1	1	4
Eat	9	3	1	3	7	7	1	4	3	3	1	7
Groom	6				1	1						5
Pace	3	5	1		1						1	8
Peer Into Nest	2	1	1			3	1	1				1
Lie In Cage			1		1	1	1	1				
Alert Toward Noise	1											
Shake	4	3	1	2	3	2	2		1	2	2	1
Yawn and Stretch						1						3
Vomit						1						
Climb Cage Side	2	2	2	1	1		1					
Gnaw Wire										1	1	
Peer Out Of Nest	2		1									
Carry Food Into Nest							7					
Total	150	88	35	49	89	84	78	50	30	33	72	83

N = 40 females.

Cont'd

APPENDIX II (Cont'd)  
8 May 1970

Event	End of time interval											
	1014	1029	1044	1059	1114	1129	1144	1159	1214	1229	1244	1259
Peer From Nest	11	19	9	6	8	4	2	4	5	3	2	2
Enter Cage	25	25	12	16	13	11	12	13	5	6	7	8
Enter Nest	23	29	15	15	13	10	12	14	4	5	7	7
Drink	8	12	7	5	4	6	1	3	3	2		3
Scratch With Feet	10	12	12	7	10	3	3	4		1	2	4
Scratch On Cage	7	17	8	10	5	2	1	2	1	3	2	5
Move About Cage	18	11	2	9	7	7	6	6	1		2	4
Transport Bedding	1	2	3	1	1	2	3	4		1		1
Chew Bedding		1			2	1	2					
Urinate	1	2	3	3	2	1	2	2	1	1	2	2
Defecate	3	5	5	7	6	1	4	2	2		4	5
Sniff Food	3	2	2		2	3		1		1		2
Eat	15	19	5	4	2	4	5	1		3		3
Groom	1	5	3	5	7	2	1	1		1		1
Pace	3	2	1	1	2	2	1	1		2	1	2
Peer Into Nest		1					2					
Lie In Cage	3	3	2	3				1				2
Alert Toward Noise	2	4	1		1							
Watch Other Mink	1				2	1		1				1
Shake	2	4	3	3	2	2	1	1	1	1	2	1
Yawn and Stretch	1		1		1			1				1
Peer Out Of Cage							2					
Climb Cage Side	1	1										
Vomiting		1		1								
Gnaw Wire	1										1	
Total	140	177	94	96	90	62	60	62	23	30	32	54

N = 40 females.

APPENDIX III. ACTIVITY OF EACH FEMALE FOR 1 MINUTE AFTER  
EACH SONIC BOOM OR SIMULATED SONIC BOOM

---

11 May 70 Sonic Boom Day

1058 Boom

---

55 Females

K = A female gestating when exposed to sonic booms

N = A female with a litter of kits when exposed to sonic booms

- 333 - N - Peers briefly from nest  
334 - N - Peers from nest opening then enters cage, grooms, and returns to nest.  
335 - N - Peers from nest, enters cage, scratches with hind legs, grooms, ...  
336 - N - Peers briefly from nest  
341 - K - Peers out of nest then enters box and roams around  
342 - N - Peers from nest briefly  
343 - K - Head appears briefly then enters cage, scratches, looks into box,  
then re-enters box  
344 - N - Peers from nest briefly  
347 - K - Not visible - whelping at time of booms  
348 - N - Peered briefly from nest  
349 - K - Peered briefly from nest  
350 - ? - Peered from nest and rested head on nest box hole  
351 - K - Peered briefly from nest  
352 - N - Entered cage and appeared to be routinely pacing side of cage  
353 - K - Peered briefly from nest  
357 - K - Peers out of nest opening for two minutes, then back into nest  
358 - K - Peers out of nest box then disappears again  
359 - N - Peers out of nest box briefly  
360 - N - Peers briefly out of nest box  
365 - K - Peered briefly from nest  
366 - K - Peered briefly from nest  
367 - K - Peered briefly from nest  
368 - N - Peered briefly from nest  
483 - K - Looks out of nest at 1058. Then exits nest box and leisurely  
walks around. Scratches with hind foot. Defecates, re-enters  
nest box  
484 - N - Cannot be seen before or after boom  
485 - K - Peers out of nest  
486 - K - Peers briefly from nest then disappears  
487 - N - Peers briefly from nest box  
488 - K - Peers briefly from nest box  
489 - K - Peers briefly from nest box  
490 - K - Peers briefly from nest box

Cont'd

- 495 - K - Peered briefly from nest
- 496 - K - Peered briefly from nest
- 497 - N - Peers from nest then rests head on box opening
- 498 - K - In cage - peers into nest then wanders to front of cage then returns to nest and enters
- 499 - N - Enters cage then immediately re-enters nest and peers from opening
- 500 - N - Rests head on nest box opening and lays there motionless
- 501 - N - Enters cage, immediately returns to nest and peers from opening
- 502 - N - Not visible
- 503 - Record lost
- 504 - Record lost
- 505 - Record lost
- 506 - Record lost
- 507 - N - Pulls head into nest box after peering out
- 508 - N - Cannot be seen before or after boom
- 509 - N - Peers from nest, rests head on nest box hole, yawns
- 510 - N - Peers from nest briefly
- 511 - N - In cage. Brief startle reaction then immediately resumed wandering around cage floor
- 512 - K - Peered briefly from nest
- 513 - N - Entered cage, defecated, and returned to nest box
- 514 - N - Peered briefly from nest opening
- 515 - N - Cannot be seen before or after boom
- 516 - N - Peers from nest briefly. Pulls head back in. Peers out again
- 517 - K - Peers out of box briefly
- 518 - K - Peers out of box briefly. Immediately peers out again briefly

Cont'd

11 May 70 Sonic Boom Day

1144 Boom

---

- 333 - N - Not visible
- 334 - N - Not visible
- 335 - N - Not visible
- 336 - N - Peers from nest
- 341 - K - Peers from nest briefly
- 342 - N - Not visible
- 343 - K - Peers from nest briefly
- 344 - N - Not visible
- 347 - K - Continues to lick rear quarters; no overt acknowledgment of hearing boom
- 348 - N - Peers out briefly
- 349 - K - Not visible
- 350 - ? - Peers out briefly
- 351 - K - Peers out briefly
- 352 - N - Not visible
- 353 - K - Not visible
- 357 - K - Peers out of nest briefly
- 358 - K - Not visible
- 359 - N - Peers out of nest for about 15 seconds
- 360 - N - Peers out of nest then yawns with head protruding from nest
- 365 - K - Not visible
- 366 - K - Not visible
- 367 - K - Peers briefly from nest
- 368 - N - Peers briefly from nest
- 483 - K - Peered out of nest briefly
- 484 - N - Not visible
- 485 - K - Peered out of nest briefly
- 486 - K - Not visible
- 487 - N - Peers out and yawns
- 488 - N - Not visible
- 489 - K - Not visible
- 490 - K - Peers out briefly
- 495 - K - Peers from nest briefly
- 496 - K - Peers from nest briefly
- 497 - N - Peers out briefly
- 498 - K - Peers out briefly
- 499 - N - Not visible
- 500 - N - Peers out briefly
- 501 - N - Peers out briefly
- 502 - N - Visible
- 503 - N - Peers briefly from nest
- 504 - N - Peers from nest 20 seconds after boom
- 505 - N - Peers briefly from nest
- 506 - K - Peers briefly from nest

Cont'd

11 May 70 - 1144 Boom continued

---

- 507 - N - Peers from nest briefly and yawns
- 508 - N - Peers from nest briefly
- 509 - N - Peers from nest briefly
- 510 - N - Peers from nest and yawns
- 511 - N - Continued pacing in cage front
- 512 - K - Peers from nest briefly
- 513 - N - After brief pause, head showed and peered around briefly
- 514 - N - Not visible
- 515 - N - Peers from nest briefly
- 516 - N - Peers briefly from nest
- 517 - K - Not visible
- 518 - K - Peers from nest briefly

Cont'd

11 May 1970 Sonic Boom Day

1200 Boom

---

333 - N - Not visible  
334 - N - Not visible. Enters nest one minute later and scratches  
335 - N - Not visible  
336 - N - Not visible  
341 - K - Peers from nest briefly  
342 - N - Not visible  
343 - K - Peers from nest briefly then yawns  
344 - N - Not visible  
347 - N - Visible  
348 - N - Head resting on nest hole - does not move  
349 - K - Not visible  
350 - ? - After pause, lazily looks out of hole for moment  
351 - K - Not visible  
352 - N - Not visible  
353 - K - Not visible  
357 - K - Peers out of nest briefly  
358 - K - Not visible  
359 - N - Not visible  
360 - N - Peers out of nest briefly  
365 - K - Not visible  
366 - K - Not visible  
367 - K - Not visible  
368 - N - Not visible  
483 - K - Peers out of nest briefly  
484 - N - Not visible  
485 - K - Not visible  
486 - K - Not visible  
487 - N - Not visible  
488 - N - Not visible  
489 - K - Not visible  
490 - K - Enters cage, wanders about, urinates, defecates, drinks ...  
495 - K - Peers from nest briefly  
496 - K - Not visible  
497 - N - Peers out briefly  
498 - K - Peers out briefly  
499 - N - Not visible  
500 - N - Peers out briefly  
501 - N - Enters cage and immediately returns to nest  
502 - N - Not visible  
503 - Record lost  
504 - Record lost  
505 - Record lost  
506 - Record lost

Cont'd

11 May 70 - 1200 Boom continued

---

- 507 - N - Quickly pulls head into nest - had been peering about
- 508 - N - Not visible
- 509 - N - Not visible
- 510 - N - Out in cage; peers out of cage front and sniffs
- 511 - N - Peered from nest briefly
- 512 - K - Not visible
- 513 - N - Not visible
- 514 - N - Not visible
- 515 - N - Not visible
- 516 - N - Not visible
- 517 - K - Peers from nest briefly
- 518 - K - Not visible

Cont'd

12 May 70 Simulation Exposure Day

1110 Boom

---

20 Females

K = A female gestating when exposed to sonic booms  
N = A female with a litter of kits when exposed to sonic booms

- 295 - N - Peers briefly from nest
- 296 - N - Rushed into nest. Had been grooming in cage. Immediately returns to cage and scratches.
- 297 - K - Not visible
- 298 - N - Not visible
- 299 - K - Not visible
- 300 - K - Peers out of nest briefly, looks around slowly and calmly
- 301 - N - Not visible
- 302 - N - Not visible
- 303 - N - Peers out of nest briefly, then enters and transports bedding into cage
- 304 - N - Not visible
- 305 - N - Peers out of nest briefly
- 306 - N - Peers out of nest briefly
- 309 - N - Peers from nest briefly
- 311 - K - Not visible
- 312 - N - Moves to front of cage and peers out
- 313 - N - Not visible
- 314 - K - Peers from nest and moves  $\frac{1}{2}$ -way out briefly
- 315 - N - Peers out briefly
- 316 - K - Not visible
- 317 - K - Not visible
- 318 - N - Peers briefly from nest

Cont'd

12 May 70 Simulation Exposure Day

1154 Boom

---

- 295 - N - Had head in nest hole - appeared to startle briefly
- 296 - N - Not visible
- 297 - K - Not visible
- 298 - N - Not visible
- 299 - K - Not visible
- 300 - K - Hangs head on doorway and appears to doze
- 301 - N - Not visible
- 302 - N - Not visible
- 303 - N - Not visible
- 304 - N - Not visible
- 305 - N - Not visible
- 306 - N - Peers out briefly
- 309 - N - Peered from nest briefly (less than 10 seconds)
- 311 - K - Not visible
- 312 - N - Not visible
- 313 - N - Not visible
- 314 - K - Not visible
- 315 - N - Not visible
- 316 - K - Not visible
- 317 - K - Not visible
- 318 - N - Peers briefly from nest

Cont'd

12 May 70 Simulation Exposure Day

1210 Boom

---

- 295 - N - Peers from nest then rests head on hole
- 296 - N - Not visible
- 297 - K - Not visible
- 298 - N - Peers from nest briefly
- 299 - K - Not visible
- 300 - K - Head rested on hole after boom, appears sleepy
- 301 - N - Not visible
- 302 - N - Not visible
- 303 - N - Not visible
- 304 - N - Not visible
- 305 - N Peers out of nest briefly
- 306 - N - Continues to move about cage. No startle reaction apparent
- 309 - N - Peers from nest briefly
- 311 - K - Not visible
- 312 - N - Not visible
- 313 - N - Appears startled and jerks head back into nest box, then enters cage. Sniffs around
- 314 - K - Not visible
- 315 - N - Not visible
- 316 - K - Not visible
- 317 - K - Not visible
- 318 - N - Head was in box door grooming - Alerts briefly, then pulls head into box

Cont'd

APPENDIX IV. GROUP SUMMARY OF ACTIVITY 24 HOURS AFTER SONIC BOOM EXPOSURE

Event	End of time interval											
	1014	1029	1044	1059	1114	1129	1144	1159	1214	1229	1244	1259
Peer from nest		1			2	1	1	2	2	4	3	4
Enter cage		2	1	3	4	7	5	2	4	12	4	1
Enter nest		2	1	3	4	6	6	3	3	13	3	2
Drink		2	1		1		1	1	4	2		2
Scratch with feet		1	3	1	3	2	1	1	3	1		3
Scratch on cage		2	2		1	2	3			1	2	
Move about cage		1	2	1	2	4	2		1	3	1	
Transport bedding			1	1	1	2	4		3	1		
Urinate		1	1		2				1			1
Defecate		1			1	1	1		1	1		
Sniff food		1	1			1	1			2	1	
Eat		1	2		1	2	3			1		
Groom				1		2		1	1			1
Peer into nest								1				
Lie in cage				1			1			1	2	
Watch other mink								1				
Peer out of cage				1								
Yawn and stretch					1							
Climb cage side								1				
Total	0	15	15	12	23	30	29	13	23	42	16	14

N = 12 females.

APPENDIX V. BACKGROUND NOISES IDENTIFIED BY OBSERVERS ON ALL OBSERVATION DAYS

Sonic Boom Test Site

5/7/70

1003 - Logging truck on road  
 1036 - Logging truck on road  
 1051 - Logging truck on road  
 1112 - Logging truck on road  
 1117 - Logging truck on road  
 1137 - Logging truck on road  
 1233 - Logging truck on road  
 1255 - Logging truck on road

5/8/70

1016 - Logging truck on road  
 1026 - Radio test  
 1048 - Logging truck on road  
 1059 - Logging truck on road  
 1104 - Pick-up on road  
 1107 - Logging truck on road  
 1110 - Logging truck on road  
 1124 - Logging truck on road  
 1127 - Logging truck on road  
 1145 - Logging truck on road  
 1150 - Single-engine aircraft overhead  
 1152 - Logging truck on road  
 1216 - Logging truck on road  
 1236 - Logging truck on road  
 1246 - Logging truck on road

5/9/70

1008 - Logging truck on road  
 1011 - Logging truck on road  
 1024 - Logging truck on road  
 1036 - Logging truck on road  
 1050 - Logging truck on road  
 1111 - Logging truck on road  
 1121 - Logging truck on road  
 1124 - Hammer sounds from road  
 1130 - Logging truck on road  
 1133 - Single-engine aircraft overhead  
 1138 - Logging truck on road  
 1145 - Pick-up on road  
 1154 - Logging truck on road  
 1201 - Pick-up on road  
 1202 - Single-engine aircraft overhead  
 1209 - Logging truck on road  
 1226 - Logging truck on road  
 1233 - Pick-up on road  
 1253 - Car on road  
 1259 - Pick-up on road

5/11/70 - Sonic boom test day

1000 - Caretakers in sheds  
 1001 - Pick-up on road  
 1002 - Pick-up on road  
 1010 - Logging truck on road  
 1011 - Logging truck on road  
 1015 - Car on road  
 1016 - Logging truck on road  
 1021 - Logging truck on road  
 1032 - Jets at high altitude  
 1034 - Logging truck on road  
 1038 - Pick-up on road  
 1039 - Jets at high altitude  
 1058 - Sonic boom  
 1115 - Dog barking in distance  
 1116 - Logging truck on road  
 1124 - Logging truck on road  
 1131 - Pick-up on road  
 1137 - Pick-up on road  
 1138 - Jets at high altitude  
 1142 - Logging truck on road  
 1144 - Sonic boom  
 1145 - Logging truck on road  
 1215 - Cameraman makes brief noise  
 1230 - Caretakers enter mink sheds  
 1232 - Pick-up on road  
 1245 - Logging truck on road  
 1255 - Pick-up on road  
 1307 - Logging truck on road  
 1322 - **Road-building blast**  
 1323 - Logging truck on road  
 1328 - Pick-up on road

Cont'd

APPENDIX V (Cont'd)

Simulated Sonic Boom Test Site

5/10/70

---

- 1047 - Noise of falling board
- 1051 - Pick-up on road
- 1055 - Rifle fire in background plus faint human voices
- 1059 - Rifle fire ceases
- 1121 - Single-engine aircraft overhead
- 1246 - Pick-up on road

5/12/70

- 1008 - Logging truck on road
- 1009 - Caretakers in sheds
- 1013 - Noise from TV shed
- 1038 - Caretakers leave sheds
- 1045 - Distant sound of machinery
- 1102 - Car on road
- 1110 - Simulated boom
- 1153 - Simulated boom
- 1210 - Simulated boom
- 1234 - Single-engine aircraft overhead
- 1235 - Caretakers enter sheds

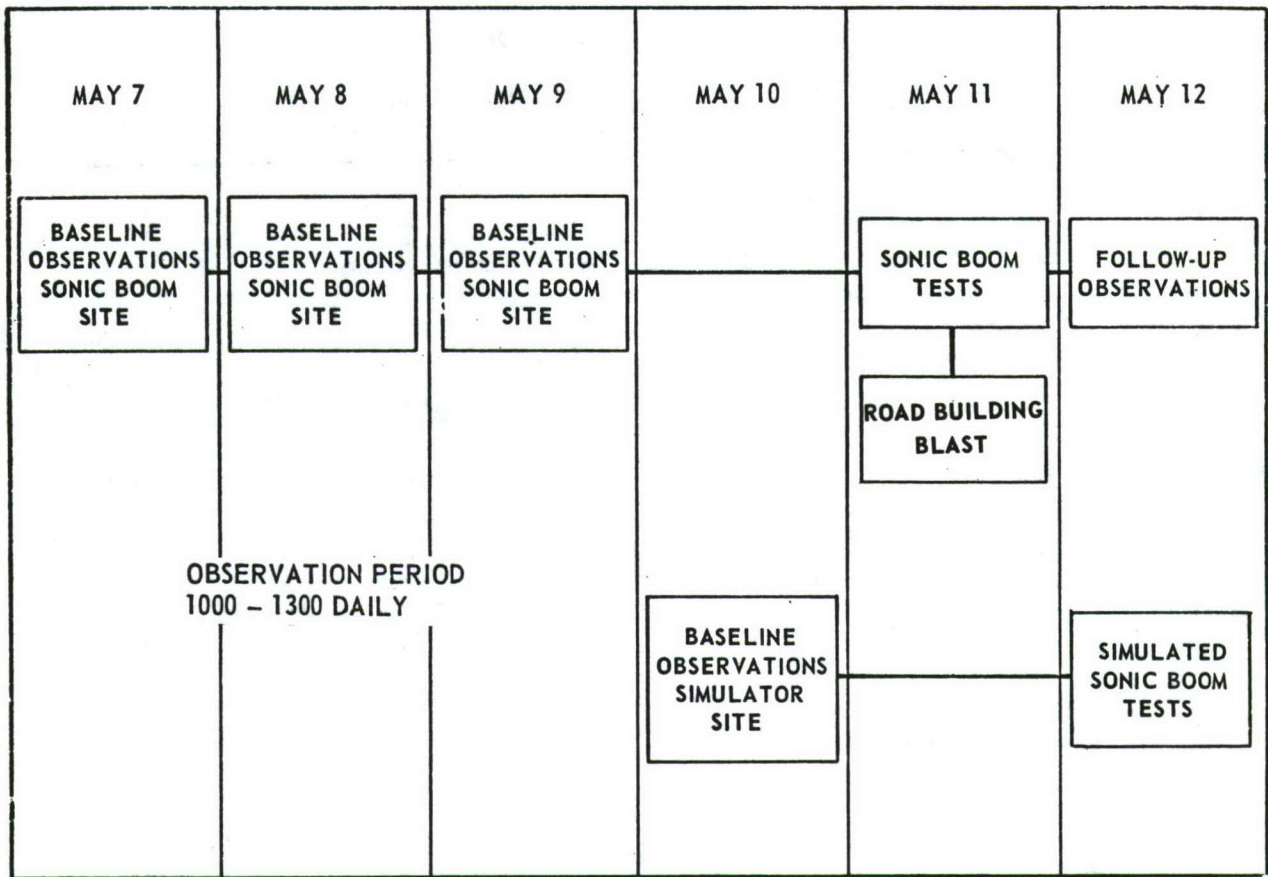

Figure 1.--Block diagram of observation program

Pathologic Findings in Adult and Newborn Mink (Mustela vison)  
Exposed to Real and Simulated Sonic Booms

Farrel R. Robinson, Walter E. Brewer, and Glenn A. Huttenhauer <sup>1,2/</sup>

INTRODUCTION

The purpose of the entire experiment was to determine the effects of sonic booms on pregnant mink, whelping females, and females with young kits. In order that the study be complete, necropsy examinations were conducted on all mink that died during the time periods immediately before exposure and immediately after exposure. The first mink was examined on 30 April 1970 and the last on 13 May 1970. During this period 16 adult mink, 220 newborn kits, and 1 placenta were examined (Table 1). Tissues from all adult mink were saved for microscopic examination, and 36 kits were saved in toto, as the 1 placenta.

MATERIALS AND METHODS<sup>3/</sup>

With three exceptions, all mink were presented for gross examination within 24 hours of their death. The exceptions were three animals that had died during the month prior to our arrival at Petersburg, Alaska. The adult animals were identified according to animal number and whether they were from the sonic boom test site, simulated sonic boom test (simulator) site, control group, or fur farm (and therefore not part of the experiment). All mink were either brought directly into the necropsy laboratory from one of these sites or were placed under refrigeration until examined.

A routine necropsy examination was done on each adult animal, and microbiologic samples were obtained aseptically from several. The weight was routinely taken of the brain, heart, lungs, liver, spleen, kidneys, and adrenal glands. Weights of the thyroid glands were taken on eight adult mink. Routine sets of tissue were saved from each adult mink and placed in 10% formalin. The following day the formalin was changed and the tissues allowed to become fixed until the day before departure. At this time the tissues were placed in plastic bags and sealed for shipment. The tissues were prepared for microscopic examination at the Armed Forces Institute of Pathology (AFIP); the routine stain used was hematoxylin

---

<sup>1/</sup> Lt. Col., U.S. Air Force, Veterinary Corps, Armed Forces Institute of Pathology, Washington, D.C. 20305; Lt. Col., U.S. Air Force, Veterinary Corps, U.S.A.F. Environmental Health Laboratory, Kelly Air Force Base, Tex. 78241; Lt. Col. U.S. Air Force, Biomedical Sciences Corps, School of Aerospace Medicine, Brooks Air Force Base, Tex. 78235.

<sup>2/</sup> The views expressed herein are those of the authors and do not necessarily reflect the views of the U.S. Air Force or the Department of Defense.

<sup>3/</sup> In conducting the research described in this report, the investigator adhered to the "Guide for Laboratory Animal Facilities and Care," as promulgated by the Committee on the Guide for Laboratory Animal Facilities and Care of the Institute of Laboratory Animal Resources, National Academy of Sciences-National Research Council.

Table 1.--Summary of Number of Mink Cases Examined

	Receiving gross examination	Receiving microscopic examination
Adults	16	16
Kits	220	36
Placenta	<u>1</u>	<u>1</u>
Total	237	53

and eosin, while special preparations included periodic acid-Schiff, Gomori methenamine-silver, MacCallum-Goodpasture, Brown and Brenn, Giemsa, and Gridley stains.

Mink kits were identified according to the dam's number. Body weights were taken and gross examinations made of the exterior. Kits were randomly selected for histopathologic, bacteriologic, and virologic examinations. Those saved for histopathologic examination were immersed in 10% formalin and processed in the same manner as the adult mink tissues. At the AFIP they were again weighed after being in formalin for 4 to 6 weeks, and the stomachs were examined for the presence of milk curd. The thoracic viscera were removed, and extrapulmonary tissues were dissected away from the lungs, which were then placed in water to determine whether they would float. The lungs and heart were embedded as separate organs, while cross-sections were made through the head, neck, and abdominal viscera. These tissues were embedded and processed in the same manner as the adult mink tissues.

## RESULTS

Gross Findings--Six of the adult mink died of spontaneous disease (Table 2). Ten adult mink were selected by the biologist in charge and killed by us for microbiologic samples. Six of these animals had significant gross lesions, while the other four had no gross lesions (Appendix). Of the six animals that died, one was from the sonic boom site, three were from the simulator site, one was a control, and one was from the fur farm. Of the 10 adult mink that were killed, 5 were from the sonic boom test site, 2 were from the simulator site, 2 were controls, and 1 was from the fur farm. There were no deaths in adult mink during the immediate postexposure period. Three adult mink that were killed in the postexposure group had significant gross lesions, and four did not.

The cause of death for each adult mink, given in Table 3, is based on the gross diagnosis for each animal and was later confirmed by histopathologic examination. Of the six animals that died, two had exudative pleuritis, one had necrotic rhinitis, one had a septicemia and multiple infarction, and two died of complications arising during whelping. Of the six animals that were killed and had significant gross lesions, three had exudative pleuritis, one had multiple abscesses and purulent metritis, one had a retained placenta, and one had a ruptured uterus. In these groups combined, six had severe gross lesions involving the respiratory tract, five had severe gross lesions involving the reproductive tract, and one had multiple infarctions of the visceral organs.

Exudative pleuritis was the most common severe gross lesion observed. Of the five mink affected, the pleuritis was bilateral in four and unilateral in one. The amount of fibrinopurulent material

TABLE 2.--Summary of numbers of mink examined, by group

Group	Adults*				Kits**						
	Killed										
	Died Spon- taneously	Having gross lesions	No gross lesions		Examined grossly	Examined microscopically	Pre	Post			
Pre***	Post***	Pre	Post	Pre	Post	Pre	Post				
Test	1	0	2	1	0	0	2	41	67	11	5
Simulator	3	0	1	0	0	0	1	28	10	5	1
Control	1	0	0	1	0	0	1	36	38	11	3
Farm	1	0	0	1	0	0	0	0	0	0	0
Total	6	0	3	3	0	0	4	105	115	27	9

\*Gross and microscopic examinations were done on all adult mink.

\*\*All kits were dead on arrival except for a limited number that were killed for microbiologic studies.

\*\*\*Pre = preexposure group.

Post = postexposure group.

TABLE 3.--Adult mink necropsied and cause of death

Date necropsied (1970)	Necropsy No.*	Mink No.	Sex	Source	Means of death**	Cause of death (gross diagnoses)
Preexposure						
30 Apr	M-1	RA128	F	Simulator	D	Exudative pleuritis and pneumonia. Died 29 Mar.
30 Apr	M-2	RA166	F	Simulator	D	Necrotic rhinitis
30 Apr.	M-3	R636	F	Control	D	Exudative pleuritis. Died 27 Apr.
30 Apr.	M-4	R326	F	Simulator	D	Septicemia and multiple infarction. Died 28 Apr.
1 May	M-5	R178	F	Test	K	Sodium pentobarbital; multiple abscesses and purulent metritis
1 May	M-6	R426	F	Simulator	K	Sodium pentobarbital; exudative pleuritis
4 May	M-7	R44	F	Test	K	Sodium pentobarbital; exudative pleuritis and pneumonia
6 May	M-13	B110	F	Farm***	D	Dystocia
10 May	M-62	RA90	F	Test	D	Dystocia

Table 3. ---Continued

Postexposure								
11 May	M-135	R266	F	Test	K	Sodium pentobarbital; no gross lesions		
11 May	M-190	R610	F	Control	K	Sodium pentobarbital; retained placenta		
12 May	M-191	R318	F	Simulator	K	Sodium pantobarbital; no gross lesions		
12 May	M-230	R456	F	Control	K	Sodium pentobarbital; no gross lesions		
13 May	M-233	R150	F	Test	K	Sodium pentobarbital; ruptured uterus		
13 May	M-234	R198	F	Test	K	Sodium pentobarbital; no gross lesions		
13 May	M-238	R211	M	Farm***	K	Cervical disarticulation; exudative pleuritis		

\*All necropsy Nos. smaller than M-98 were of animals taken before test day.

\*\*K = killed; D= died spontaneously.

\*\*\*Not part of experiment.

measured in three of the mink with bilateral involvement amounted to 61, 78, and 100 ml of the fluid, respectively. This fluid in two cases was tinged with red, presumably blood. Of the five cases, only two had gross evidence of pneumonia.

The sixth animal with severe lesions of the respiratory system had severe necrotic rhinitis. This mink had had a unilateral nasal exudate prior to death. The exact mechanism of the death of this animal was not determined, but asphyxiation was the probable cause.

Of the five animals having severe gross lesions in the reproductive tract, one had a ruptured uterus. The left horn of the uterus of this animal was well involuted, but the right horn contained remnants of the fetus and the attendant placenta, portions of which protruded through the wall of the uterus near the ovarian end. In the second animal the right horn was enlarged at the ovarian end, and when it was incised, placental remnants were found. In this same area there were also adhesions of the uterus to the omentum. Of the two mink with gross lesions related to the delivery of kits at whelping time, one had a kit lodged in the body of the uterus in a posterior-first presentation. In the second of this pair the exact problem was not determined. There were six mature fetuses in the uterus of this animal, three in each horn. The fetal portion of the placentome was easily detached from the uterus, and there was a moderate amount of bloody fluid in the lumen of the uterus. The myometrium was red and flaccid. The fifth animal in this group had six implantation sites, which appeared as enlargements in the uterus, three in each horn. These sites were necrotic and covered with a reddish-gray exudate. The gross lesions in this animal, however, were not restricted to the genital tract. There was a rather large, poorly defined sublumbar abscess in this mink that extended into the vertebrae dorsally and, in terms of severity, probably overshadowed the lesions in the uterus. The last animal with severe gross lesions had multiple infarcts in the kidneys and spleen. This type of lesion is commonly associated with a septicemic process, but a causative organism was not identified.

Four other adult female mink were killed with sodium pentobarbital. No outstanding gross lesions were noted in these.

Body and organ weights of adult mink are given in Table 4, and percent of body weight of the individual organs is given in Table 5. These organ weights and percentages are of little value from a statistical standpoint because of the limited number of observations and the variety of pathologic lesions seen in the various animals.

The mean body weight of adult mink was 968 gm. The mean weight of the heart was 6.1 gm and made up 0.64% of the body weight. The mean weight of the lungs was 10.4 gm, which comprised 1.12% of the body weight. There was considerable variation in the percentage of body weight of the lungs, but none of the lungs exceeded 2% of the total body weight.

TABLE 4.--Body and organ weights of adult mink that died or were killed

Necropsy No.	Body (gm)	Heart (gm)	Lungs (gm)	Liver (gm)	Kidneys (gm)	Spleen (gm)	Brain (mg)	Adrenals (mg)	Thyroids (mg)
<b>Preexposure</b>									
M-1	962	6.1	15.3	42.0	6.2	9.3	7.3	140	--*
M-2	990	7.8	16.0	46.4	7.7	13.7	6.7	192	-
M-3	820	8.0	15.7	34.7	7.2	13.9	8.3	165	-
M-4	520	5.1	9.1	57.8	12.2	4.2	7.2	170	-
M-5	750	6.0	6.6	42.6	9.4	15.3	7.6	--**	-
M-6	974	6.0	13.8	45.4	7.0	21.2	6.3	155	-
M-7	900	4.5	10.7	31.1	7.0	6.5	7.7	158	93
M-62	1,100	7.3	11.1	42.0	7.2	17.3	7.3	94	72
<b>Postexposure</b>									
M-135	1,200	6.9	7.5	31.5	5.8	7.8	7.4	95	75
M-190	920	3.9	7.5	30.3	4.6	10.0	5.6	106	76
M-191	1,050	5.8	7.3	31.7	6.3	11.5	7.8	110	65
M-230	1,120	6.1	7.6	28.0	3.6	9.2	8.2	130	62
M-233	1,150	6.3	9.1	35.7	7.7	12.0	8.2	190	69
M-234	1,090	5.0	8.1	22.5	5.8	9.8	6.1	115	53
Sum	13,546	84.8	145.4	521.7	97.7	161.7	101.7	1,820	565
Mean	968	6.1	10.4	37.3	7.0	11.6	7.3	130	71
Number	14	14	14	14	14	14	14	14	8

\*Weight not taken.

\*\*Weight not valid.

TABLE 5.--Percent of body weight of organs of adult mink that died or were killed

Necropsy No.	Heart	Lungs	Liver	Kidneys	Spleen	Brain	Adrenals	Thyroids
<b>Preexposure</b>								
M-1	0.63	1.59	4.4	0.64	0.97	0.76	0.015	-*
M-2	0.79	1.62	4.7	0.78	1.38	0.68	0.019	-
M-3	0.98	1.91	4.2	0.88	1.70	1.01	0.020	-
M-4	0.98	1.75	11.1	2.35	0.81	1.38	0.033	-
M-5	0.80	0.88	5.7	1.25	2.04	1.01	-**	-
M-6	0.62	1.42	4.7	0.72	2.18	0.65	0.016	-
M-7	0.50	1.19	3.5	0.78	0.72	0.86	0.018	0.0100
M-62	0.66	1.01	3.8	0.6F	1.57	0.66	0.008	0.0065
<b>Postexposure</b>								
M-135	0.58	0.62	2.6	0.48	0.65	0.62	0.008	0.0062
M-190	0.42	0.82	3.3	0.50	1.09	0.61	0.012	0.0083
M-191	0.55	0.70	3.0	0.60	1.10	0.74	0.010	0.0062
M-230	0.54	0.68	2.5	0.32	0.82	0.73	0.012	0.0055
M-233	0.55	0.79	3.1	0.67	1.04	0.71	0.017	0.0060
M-234	<u>0.46</u>	<u>0.74</u>	<u>2.1</u>	<u>0.53</u>	<u>0.90</u>	<u>0.56</u>	<u>0.011</u>	<u>0.0049</u>
Sum	9.06	15.72	58.7	11.15	16.97	10.98	0.199	0.0536
Mean	0.64	1.12	4.2	0.80	1.21	0.78	0.014	0.0067
Number	14	14	14	14	14	14	13	8

\*Weight not taken

\*\*Weight not valid

The mean weight of the liver was 37.3 gm, making up 4.2% of the body weight. There was only one outstanding liver weight, and this was in case M-4, in which the liver weighed 11.1% of the body weight. The mean weight of the kidneys was 7.0 gm, constituting 0.80% of the body weight. There were only two animals in which the weight of the kidney appeared to be increased. These were cases M-4 (mink with metritis and sublumbar abscess) and case M-5.

The mean weight of the spleen was 11.6 gm, making up 1.21% of the body weight. There was considerable variation in the weights of the spleen, with one exceeding 20 gm (case M-6, mink with severe pleuritis, killed with sodium pentobarbital). These variations in weights were probably due to the use of sodium pentobarbital as an agent of euthanasia and to the variable degree of extramedullary hematopoiesis seen in the different spleens.

The mean weight of the brain was 7.3 gm, which constituted 0.78% of the body weight. No outstanding changes in weights of the brains were revealed by inspection. The mean weight of the adrenal glands was 130 mg, making up 0.014% of the body weight. There is considerable variation in the weights of the adrenals, but there did not appear to be any outstanding changes. Of the eight sets of thyroids weighed, the mean weight was 71 mg, with no outstanding differences, making up 0.0067% of the body weight.

The numbers of kits from the various sites are given in Table 2, which shows that 220 kits were given a gross examination. This examination was necessarily superficial because of the large numbers of kits and the time available for examination. Of these, 36 were saved for microscopic examination. Gross lesions in the newborn mink kits were absent, reflected a stage of postmortem decomposition, or showed evidences of lacerations occurring after death (Table 6).

Microscopic Findings.--The histopathologic lesions observed in the adult mink are summarized in Table 7 (also in Appendix). The lesions are categorized by organ system and numbers of diagnoses according to the primary system involved in the death of the animal. There are six animals with primary respiratory disease, five with primary genital disease, one with multiple infarctions, and four with no gross lesions. This type of categorization does not indicate the severity of the lesions but only whether a primary diagnosis was made on the individual case.

In the respiratory system the most severe lesions were seen in those adult mink with fibrinopurulent pleuritis and the one animal with the severe necrotic rhinitis. The animals with the pleuritis had lesions characterized by a fairly uniform, thick layer of chronic inflammatory tissue on both the visceral and parietal pleural surfaces. This tissue was composed of fibrin and maturing strands of fibrous tissue interspersed with necrotic inflammatory cells that were primarily neutrophils. In one case there was a membrane, covered with fibrin and cells, floating

TABLE 6.--Summary of observations on newborn mink kits

Necropsy No.	Dam No.	Source	Manner of death	Fresh body weight (gm)	Fixed body weight (gm)	Change in body weight (gm)	Gross abnormality	Lungs float	Food in stomach	Microscopic observations
Preexposure										
M-8	R244	Test	D	5.1	5.4	+0.3	NGL	0	0	Mild focal hem., brain
M-12	R692	Cont.					NGL	-	-	Normal expelled placenta
M-14	R236	Cont.	D	9.1	8.4	-0.7	NGL	0	0	Mild diffuse hem., subcutis of head
M-18	R528	Cont.	D	4.8	5.5	+0.7	NGL	0	0	Mild focal hem., brain
M-21	RA232	Cont.	D	8.8	10.0	+1.2	NGL	0	0	NML
M-26	RA194	Sim.	D	10.0	10.4	+0.4	NGL	0	0	NML
M-29	RA98	Test	D	3.1	2.8	-0.3	NGL	0	0	Mod. focal hem., subcutis of head
M-32	R240	Cont.	D	7.4	9.0	+1.6	NGL	0	0	Mild focal hem., subcutis of neck

Table 6.--Continued

M-37	R482	Cont.	D	2.5	3.7	+1.2	Immature, dissicated	0	0	Mod. PMD
M-39	R628	Cont	D	3.7	4.8	+1.1	NGL	+	0	Mod. focal hem., brain.
M-41	RA306	Cont.	D	8.3	9.8	+1.5	NGL	0	0	NML lung
M-45	R690	Cont.	D	7.8	8.1	+0.3	NGL	0	0	Mild focal hem., brain
M-49	R36	Test	D	7.2	6.0	-1.2	NGL	0	0	NML
M-53	R98	Test	D	10.3	8.6	-1.7	NGL	0	0	Mod. congestion, choroid plexus of brain
M-57	RA238	Test	D	5.2	3.8	-1.4	NGL	0	0	Mild congestion, choroid plexus of brain
M-60	R302	Sim.	D	10.0	10.6	+0.6	NGL	0	0	Mild focal hem., brain and sub- cutis of head

Table 6.---Continued

M-63	R18	Test	D	6.7	8.6	+1.9	Skin over head lacer- ated	+	0	Mild focal hem., kidney
M-67	R20	Test	D	5.2	5.5	+0.3	NGL	0	0	NML
M-72	R86	Test	D	10.2	12.8	+2.6	NGL	0	0	NML
M-75	R102	Test	D	5.6	7.6	+2.0	NGL	0	0	Mild diffuse hem., subcutis of neck, Mild congestion, choroid plexus of brain
M-78	R130	Test	D	6.9	7.0	+0.1	NGL	0	0	NML
M-80	R150	Test	D	10.2	10.7	+0.5	NGL	0	0	Mild focal hem., subcutis of head intestine
M-84	R170	Sim	D	4.7	5.4	+0.7	NGL	0	0	NML
M-87	R440	Sim	D	6.9	7.6	+0.7	Reddened dorsal cer- vical area	0	0	Mild diffuse hem., subcutis of head, Mild focal edema and hem., skin of neck

Table 6.--Continued

M-89	R480	Cont.	D	7.6	8.9	+1.3	NGL	0	0	NML	
M-95	R610	Cont.	D	7.0	8.5	+1.5	NGL	0	0	Mod. diffuse hem., subcutis of head.	
										Mild to mod. focal congestion and hem., sub- cutis of neck	
M-97	R724	Cont.	D	7.2	8.9	+1.7	Necrotic rear qtrs.	0	0	Mod. PMD	
M-137*	RA186	Sim.	D	7.9	8.8	+0.9	Lacerated rear qtrs.	0	0	NML	
Postexposure											
M-100	R2	Test	D	10.2	12.1	+1.9	NGL	0	0	Mod. diffuse hem., subcutis of head	
M-108	R50	Test	D	4.6	6.4	+1.8	NGL	0	0	NML	
M-117	R258	Test	D	5.4	4.7	-0.7	NGL	0	0	Severe PMD	
M-125	R150	Test	D	6.5	7.4	+0.9	NGL	0	0	NML	
M-130	R266	Test	D	12.7	11.3	-1.4	NGL	0	0	Mod focal hem., brain	

Table 6.--Continued

M-157	R456	Cont.	D	9.1	10.7	+1.6	NGL	0	0	NML	
M-165	RA222	Cont.	D	5.0	4.8	-0.2	NGL	0	0	Mild focal acute pneumonitis.	
M-175	R528	Cont.	D	9.2	9.7	+0.5	Abrasions	0	0	Severe focal edema Moderate PMD	
							on neck and back			and necrosis, glands of neck, Mod. to severe	
M-193	R318	Sim.	D	5.3	6.1	+0.8	Lacerations	0	0	Mild focal hem., heart, lungs, leg; foot missing	PMD

Abbreviations:

0 = Negative result.

+ = Positive result.

D = Died spontaneously.

K = Killed.

NGL = No gross lesion.

Table 6.--Continued

NML = No microscopic lesions.

PMD = Postmortem decomposition.

mod. = Moderate.

hem. = Hemorrhage.

cont. = Control.

sim. = Simulator.

#Necropsy No. M-137, from the simulator site, is preexposure as well as all Nos. smaller than M-98.

Table 7.--Summary of histopathologic findings in 16 adult mink

Finding, by organ system	Primary disease			No gross lesion (four mink)
	Respiratory (six mink)	Genital (five mink)	Infarction (one mink)	
<b>Respiratory</b>				
Rhinitis	1	-	-	-
Pleuritis	5	-	1	-
Pneumonia	2	-	-	-
Pneumonitis	1	1	-	-
Hemorrhage	2	2	-	2
Congestion	1	2	-	2
Edema	-	2	-	1
Bronchitis	1	-	-	-
Bronchiolitis	1	1	-	-
Heteroplastic bone	2	2	1	-
<b>Genital (female)</b>				
<b>Uterus</b>				
Metritis	-	3	-	2
Endometritis	-	3	-	-
Necrosis	-	1	-	-
Serositis	-	2	-	-
Hemorrhage	-	1	-	-
Congestion	-	1	-	-
Edema	-	1	-	-
Retained placenta	-	1	-	-
Postmortem decomposition (fetus)	-	1	-	-

Table 7.--Continued

Vagina				
Vaginitis	-	1	-	-
Hemorrhage	-	1	-	1
Genital (male)				
Hypospermia	1	-	-	-
Epididymitis	1	-	-	-
Lymphatic				
Extramedullary				
hematopoiesis	5	4	-	3
Lymphadenitis	6	2	-	-
Lymphoid de-				
pletion	3	-	-	-
Plasmacytosis	4	1	-	-
Hemorrhage	4	4	-	1
(lymph node)				
Erythrophagocytosis	1	2	-	2
Edema (lymph node)	1	-	-	-
Pigment (lymph node)	-	1	-	-
Infarction	-	-	1	-
(spleen)				
Urinary				
Kidney				
Fatty change	4	2	1	2

Table 7.--Continued

Interstitial	2	1	-	-
Nephritis				
Pyelitis	3	1	-	-
Congestion	1	-	-	-
Infarction	-	-	1	-
Urethra				
Urethritis	-	2	-	1
Digestive				
Tongue				
Glossitis	1	1	-	-
Esophagus				
Esophagitis	1	-	-	-
Stomach				
Mucosal erosions	2	1	1	-
Liver				
Hepatitis	-	2	-	1
Pericholangitis	1	1	-	-
Fatty change	1	-	1	-
Thrombosis and infarction	-	1	-	-
Gallbladder				
Cholecystitis	1	-	-	3
Hyperplasia	-	1	-	1
Ectopic pancreatic tissue	2	1	-	2
Pancreas				
Hemorrhage	-	1	-	-

Table 7.--Continued

## Cardiovascular

## Heart

Myocarditis	1	1	-	-
Epicarditis	3	-	-	-
Pericarditis	1	-	-	-
Infarction	-	-	1	-

## Endocrine

## Adrenal

Adenitis	2	-	-	-
----------	---	---	---	---

## Ocular adnexa

Conjunctivitis	1	-	-	-
Concretions (lacrima gland)	1	-	-	-

## Skin

Wound	-	-	1	1
-------	---	---	---	---

## Skeletal

Osteitis	1	1	-	-
----------	---	---	---	---

## Central nervous system

Meningitis	2	1	-	-
Hemorrhage	1	-	-	-

## Miscellaneous

Freezing artifact	1	-	-	-
Adenitis	-	2	-	1
Scent glands				
Abscess, sub- lumbar	-	1	-	-

Table 7.--Continued

Steatitis (non-	-	1	-	-
nutritional)				
Mammary gland	-	-	-	1
(normally secreting)				

free in the posteroventral portion of the thoracic cavity (Figure 1). The absence of pneumonic lesions (Figure 2) was striking. In only two cases were there significant focal areas of bacterial pneumonia. The necrotic rhinitis in the one mink was quite severe in that the turbinate bones on one side were completely gone (Figure 3) and had been replaced with necrotic purulent exudate. The inflammation had also caused extensive osteolytic lesions in the maxilla. The lesions on the contralateral side were not quite as severe. The respiratory lesions recorded in the other three columns were less severe and of only comparative interest.

Significant lesions in the female genital tract were seen primarily in those mink having problems in delivering their kits or complications following delivery in the immediate postpartum period. Microscopic lesions in these animals consisted primarily of degenerative and inflammatory changes in the uterus. The animal with the ruptured uterus had endometritis in the area of the rupture in addition to the mechanical tearing of the uterine wall (Figure 4). The fetus and placenta were moderately necrotic. The animal with the retained placenta also had focal necrotic endometritis in the area of the degenerating placenta (Figure 5). Focal necrotic endometritis in addition to a congested and hemorrhagic myometrium was also evident in the two mink that died during the whelping process. The fifth animal in this group also had necrotic endometritis in addition to an extensive purulent inflammation in the sublumbar muscle mass, extending upwards and causing osteitis of the body of the lumbar vertebra. The inflammation was continued dorsally into the spinal canal as a severe necrotic granulomatous pachymeningitis (Figure 6). The one male animal had minor lesions in the testicle and epididymis.

In the lymphatic system, inflammatory lesions were quite common in the visceral lymph nodes in both the group with respiratory disease and the group with genital disease. Moderate to marked extramedullary hematopoiesis of the spleen was seen in 12 of the 16 cases and was believed to be normal for this type of mink. The spleens were quite cellular and contained numerous megakaryocytes as well as developing forms of both the erythroid and myeloid series (Figure 7). The splenic infarct noted in column 3 of Table 7 was severe (Figure 8). This type of lesion was not observed in any of the other adult mink.

Lesions of the urinary tract were more common in those animals with respiratory disease than in any of the other categories. These changes were generally nonspecific in character. There was one case, a severe renal infarction (Figure 8), as noted in column 3, Table 7.

Not listed in Table 7 was an unusual observation in the medullary portions of the kidney of one mink. The epithelium of the collecting tubules in the medulla near the renal crest contained numerous eosinophilic intracytoplasmic inclusions. These inclusions (Figure 9) varied in size, but most were smaller than the nucleus of the cell and

were surrounded by a clear halo, the outer limits of which were approximately the same size as the nucleus. These inclusions were strongly PAS positive, AMP positive, and variably stained with GMS. They were not acid fast. They did not appear to be viral inclusions, and the exact nature and cause of these inclusions was not determined.

Lesions of the digestive tract were minor in nature and fairly evenly scattered between the groups. Of special interest were the mucosal erosions in the stomach, which occurred in 4 of the 16 adult mink. These erosions appeared as lytic areas in the mucosa that only occasionally extended to the basement membrane. There was often a brown granular material adhering to the surface of these lesions and on the adjacent unaffected mucosa, presumably representing blood pigments (Figure 10). These erosions appeared to be severe enough to allow some loss of blood, as reflected in clinical observations of black tarry feces in a number of animals.

Hepatic lesions were not primary in any of the adult mink examined. Fatty metamorphosis was evident in many and was responsible for the marked enlargement of the liver in one animal. In another there was an infarcted intermediate lobe of the liver in which there was a large fibrinous mass in a branch of the portal vein (Figure 11).

The finding of ectopic pancreatic tissue in the mucosa of the gallbladder was of little significance to the health of the animal, but it was of considerable academic interest, since this is an unusual location for pancreatic tissue. These areas were focal and were made up of typical acinar pancreatic tissue (Figure 12). Ductal structures associated with this acinar tissue were not evident.

Lesions of the cardiovascular system were relatively minor in nature and were associated primarily with the cases of fibrinopurulent pleuritis. Lesions in the adrenal glands, ocular adnexa, and skin were of minor importance.

Lesions in the skeletal system were of considerable importance, since the necrotic rhinitis extended into the adjacent facial bones and caused a rather severe osteitis. The same animal had a severe sublumbar abscess, and the inflammation extended into the adjacent vertebra, causing a considerable amount of osteitis.

Except for the sublumbar abscess in this animal, which was quite severe, lesions of the central nervous system were relatively minor, as were those lesions listed under "Miscellaneous."

Microscopic lesions in the mink kits were generally noncontributory in that they reflected varying stages of postmortem decomposition and, commonly, focal hemorrhages in various organs and tissues. Of special interest was the finding of inflammation of the adnexal glands over

the crest of the neck, which correlated with clinical findings of "pustular dermatitis" in kits only a few days old (Figure 13). These glands were obliterated by the inflammatory process, which was primarily necropurulent in character.

## DISCUSSION

Mink homozygous for Aleutian genes were selected for this study because they are more difficult to raise than mink of other types, and because they represent a significant portion of all mink raised in the United States. It was believed that if harmful effects of sonic booms were to be observed, they would be more likely in mink with this genetic background or would be compounded by the known difficulties of raising mink homozygous for Aleutian genes, thus giving a more stringent test. The mink used in this study were known as "Violets," which are recessive for Aleutian (al al), Platinum (pp), and Buff (Moyle-Olsen) (bm bm).

The Aleutian mink were originally thought to be the only strain of mink susceptible to what has become known as Aleutian disease (AD), but it was later determined that they were only more susceptible to the viral agent than other strains of mink. Aleutian disease is characterized by variable degrees of plasma cell infiltrations in the liver, kidneys, and other organs along with widespread perarteritis (2, 4). Because of this increase of susceptibility to the agent of Aleutian disease, particular attention was paid to the lesions in the "Violets" with respect to this disease. With the exception of observations of large numbers of plasma cells in isolated lymph nodes and equivocal mild accumulations of plasma cells in the liver and kidneys of these animals, there was no indication that Aleutian disease was expressed on a morphologic basis. The reader should compare these observations with the serologic and virologic isolation studies done at Washington State University.

Aleutian mink also have abnormal leukocytes and other characteristics of the Chediak-Higashi Syndrome (C-HS) (3, 5). These mink are reportedly weaker than standard mink, whelp fewer and less hardy kits, and are more susceptible to abscesses (6). This susceptibility to pyogenic infections probably involves the impaired functional capability of the leukocyte rather than impaired antibody response (4). It was our impression that the mink in this sonic boom study were susceptible to an unusually large variety of bacterial diseases including abscesses located primarily in the skin of the head and neck and also in other tissues. Since these mink had the Aleutian genotype, it seemed most probable that the C-HS effect was the basic reason for the presence of numerous bacterial infections.

Exudative fibrinopurulent pleuritis was the single most important disease entity causing death in this group of mink. There has been no single causative agent isolated or described for this entity, but it has been observed fairly often by pathologists who examine mink on a continuing basis (1).

The pleuritis was probably not directly related to the problem of the abscesses that were evident in all groups. Isolates from pleural fluids and lung tissues of animals with pneumonia and pleuritis included

Pasteurella multocida, Escherichia coli, and Proteus mirabilis. Staphylococcus aureus was isolated from the lung of the animal with necrotic rhinitis, while E. coli and P. mirabilis were found in the case with sublumbal abscesses and metritis. The latter two cases appeared to be expressions of the same type of response, mentioned above, that many of the mink exhibited in the form of abscesses in the head and neck region. These animals were treated over a period of several weeks prior to and during the primary experimental period.

Isolates from uterine tissues of animals with problems related to whelping included S. aureus, P. mirabilis, B-hemolytic Streptococcus of Lancefield group G, a nontypable Streptococcus, P. multocida, and a Pseudomonas species not further classified. A blood culture from one animal with a ruptured uterus also produced a B-hemolytic Streptococcus of Lancefield group G. Cultures of the uterus in killed animals without gross lesions produced S. epidermidis and a Pseudomonas similar to the one above.

Five of the females died with severe gross lesions related to the reproductive tract. These lesions, including those related to whelping, metritis, ruptured uterus, and retained placenta, are fairly common findings in any large group of gestating female animals. They were interesting lesions but of only passing concern with regard to the experiment.

The one animal with multiple infarcts of the kidneys, spleen, and heart had lesions that are often seen in animals with subacute to chronic bacterial infections. These infections are usually present in one or more organs for some time and then are disseminated to the other organs as septic emboli. The primary site of infection was not determined in this case.

The examination of the mink kits produced little information from a morphologic standpoint. Most of these kits were submitted for pathologic examination shortly after birth, and all were believed to be stillborn. This belief was substantiated on gross and microscopic examination by the fact that only two of the sets of lungs floated in water and that milk curd was not found in any of the stomachs examined. In a discussion with the staff of the Forensic Pathology Branch at the AFIP, the consensus was that whether or not the lungs float is not a reliable indication of whether the animal actually lived and breathed immediately after birth. The most reliable information was considered to be the presence or absence of milk curd in the stomach. None was found in the 36 mink kits examined. For figures on kit mortality, the reader is referred to the growth and reproduction section of this report.

## SUMMARY

Sixteen adult mink and 220 mink kits were examined on "Project COOL MINK," and all adults and 36 kits were examined microscopically. All adult mink that died and some of those that were killed had lesions of characteristic spontaneous disease commonly found in ranch Aleutian mink. Of the 12 adult mink with significant gross lesions, 6 had severe gross lesions of the respiratory system, 5 had primary lesions of the female genital system, and 1 had multiple infarcts in the spleen and kidneys. In the mink kits that were examined there were no significant gross or microscopic lesions. All of the mink that were examined apparently died of spontaneous disease, and none of the deaths could be related to the exposure to sonic booms produced by jet aircraft overflights or simulated sonic booms.

## LITERATURE CITED

1. Gorham, J. R., Griffiths, H. J. and Farrell, R. K.  
1965. Minks: Diseases and Parasites. ARS-USDA,  
Washington, D.C., Agriculture Handbook No. 175.
2. Helmboldt, C. F., and Jungherr, E. L.  
1958. The Pathology of Aleutian Disease in Mink.  
Amer. J. Vet. Res. 19: 212-222.
3. Leader, R. W., Padgett, G. A. and Gorham, J. R.  
1963. Studies of Abnormal Leukocyte Bodies in the Mink.  
Blood 22: 477-484.
4. Leader, R. W., Wagner, B. M., Henson, J. B. and Gorham, J. R.  
1963. Structural and histochemical observations of  
liver and kidney in Aleutian disease in Mink.  
Amer. J. Path. 43: 33-53.
5. Padgett, G. A., Reiquam, C. W., Gorham, J. R., Henson, J. B.  
and O'Mary, C. C.  
  
1967. Comparative Studies of the Chediak-Higashi Syndrome.  
Amer. J. Path. 51: 553-569.
6. Padgett, G. A., Leader, R. W., Gorham, J. R. and O'Mary, C. C.  
1964. The Familial Occurrence of the Chediak-Higashi  
Syndrome in Mink and Cattle. Genetics 49: 505-512.

## APPENDIX

### DETAILED NECROPSY REPORTS OF 16 CASES

30 April 1970

Necropsy No. M-1-70 (AFIP Accession 1349636)

#### Gross Findings

This female mink, RA-128, from the simulator site, died on 29 March 1970 and was frozen until thawed 29 April. This mink weighed 962 gm. The animal is rather rigid from the frozen condition and probably unsuitable for microscopic studies.

On external examination the only abnormality seen was slight soiling around the anus and the fact that the fur appeared to be rubbed off or scratched away from the right thigh. There were no apparent cutaneous tumors, bony exostoses, or malformations.

On primary incision there was no evidence of trauma, and the position and relationship of the abdominal viscera were within normal limits.

When the respiratory tract was examined, the pleural cavity contained an excessive amount of red, frozen serous fluid that had compressed the lungs considerably. The right anterior lobe of the lung was enlarged, gray, and firm. A sample was taken from this lobe for bacteriologic examination after it had been seared in a flame. After removal of approximately 0.3 gm of lung, the lung weighed 15.3 gm. The remaining lobes in the lung were collapsed, spongy, and did not show the signs of the advanced consolidation seen in the right anterior lobe.

The heart appeared to be enlarged and weighed 6.1 gm. There was not an excessive amount of fluid in the pericardial sac. It was difficult to determine whether the heart was hypertrophied or whether there was an unsymmetrical type of hypertrophy. (Later observations indicate that this heart was within normal limits grossly.) There were no lesions in the aorta.

The spleen appeared to be enlarged and weighed 9.3 gm. It was firm, dark red, and moderately moist on cut surface.

The liver weighed 42 gm, was a normal bronze color, and showed no significant lesions. There was a considerable amount of biliary imbibition into the liver, but there were no lesions of the gallbladder.

The adrenal glands weighed 140 mg and showed no significant lesions. There were no significant lesions of the pancreas or of the adrenals, thyroids, or pituitary gland. Lymph nodes near the thyroids appeared to be enlarged, being flat and approximately 0.7 cm in diameter at the greatest diameter. The pineal body was not visualized, nor were the parathyroids.

The gastrointestinal tract was void of contents, and no significant lesions were observed. Approximately 5 cm from the anus there was a 1-cm mass that appeared to be a hemorrhagic lymph node adjacent to the gastrointestinal tract.

The kidneys weighed 6.2 gm, and they were pale with a few small red petechiae scattered over the cortex. The bladder was not distended and was not opened.

The uterus was small and apparently contained no fetuses.

No lesions were noted in the area of the head, including the ear, salivary glands, scalp, and meninges. The brain was rather red and mushy after having been frozen for such a long period of time, and no significant lesions were noted.

A femur was split and put into formalin for subsequent examination of the marrow cavity if deemed necessary. Several articulations were examined, and no significant lesions were noted.

Because the animal had been frozen for such a long period of time, no other bacteriologic or virologic samples were taken.

---

Weights

---

Body	962 gm
Heart	6.1 gm
Lungs	15.3 gm
Liver	42.0 gm
Kidneys	6.2 gm
Spleen	9.3 gm
Brain	7.3 gm
Adrenals	140 mgm

---

Impression: Cause of death was related to the excessive amount of pleural exudate.

## Microscopic Findings

### Diagnoses:

1. Pleuritis, chronic, moderate, focal, lung and parietal pleura, mink.
2. Pneumonia, caseous, severe, right anterior lobe of lung.
3. Lymphoid depletion, moderate, mediastinal lymph node.
4. Pericarditis, chronic, focal, mild, pericardium at base of great vessels.
5. Artifact, freezing, moderate, all tissues.

30 April 1970

Necropsy No. M-2-70 (AFIP Accession 1349637)

### Gross Findings

This female mink, RA-166, died on 30 April 1970, and was from the simulator site. She weighed 990 gm. The animal was still limp, and there was no postmortem decomposition. There were no external scars, wounds, or abrasions.

On primary incision there were no signs of trauma in the subcutaneous fat, muscles, etc. The position and relationship of the viscera were within normal limits. At this time microbiologic samples were taken from the liver, spleen, kidney, lung, and one fetus. The brain was removed from formalin after having been immersed for approximately 5 minutes, and a portion was saved for microbiologic analyses.

On examination of the respiratory tract the lungs were seen to have multiple scattered, small petechial subpleural hemorrhages, although there were no definite areas of consolidation of any type. A sample was taken for bacteriologic examination. A sample was also taken of blood from the heart.

There were no diagnostic lesions in the heart or aorta. The heart weighed 7.8 gm.

The spleen appeared to be rather large and weighed 13.7 gm. It was gray, firm, and slightly moist on cut surface.

The liver weighed 46.4 gm. (These are estimated weights for those organs from which samples were taken for virologic and bacteriologic studies). The liver showed no diagnostic lesions and appeared to be normal in all respects. The gallbladder was not seen.

There were no visible lesions in the pancreas, thyroids, or the pituitary. The parathyroids and pineal body were not visualized.

On examination of the gastrointestinal tract, it was empty throughout its length, and no lesions were seen.

There were no visible lesions of the kidneys or the rest of the urinary tract. The urinary bladder was small and contracted and was not opened.

There were eight fetuses in the uterus, and they measured from about 1 cm to 1-1/2 cm, crown to rump, in length.

There were no external lesions in the area of the head or in the brain. The nasal half of the brain was saved for virologic examination.

One femur was saved for later bone marrow studies if indicated. Several articulations were examined, and there were no gross lesions.

---

Weights

---

Body	990 gm
Heart	7.8 gm
Lungs	16.0 gm
Liver	46.4 gm
Kidneys	7.7 gm
Spleen	13.7 gm
Brain	6.7 gm

---

Note: Subsequent information indicated that the mink had had a unilateral nasal exudate prior to death. Later examination revealed a severe necrotic rhinitis.

Impressions: The cause of death was related to the necrotic rhinitis.

Microscopic Findings

Diagnoses:

1. Rhinitis, diffuse, severe, turbinates and nose, mink.
2. Osteitis, diffuse, subacute, severe, maxilla.
3. Lymphadenitis, diffuse, severe, mandibular lymph node.
4. Glossitis, focal, subacute, minimal, tongue.
5. Hemorrhage and congestion, focal, moderate, lung.
6. Heteroplastic bone, focal, mild, lung.
7. Bronchitis and bronchiolitis, subacute, focal, mild, lung.
8. Esophagitis, subacute, focal, mild, esophagus.
9. Plasmacytosis, diffuse, moderate, lymph node.
10. Lymphadenitis, subacute, moderate, lymph node.
11. Adenitis, subacute, multifocal, mild, cortex of adrenal gland.
12. Congestion, moderate, larger vessels of the kidney.
13. Vacuolation, diffuse, moderate, tubular epithelium of the kidney, probably fat.
14. Extramedullary hematopoiesis, diffuse, severe, spleen.
15. Leptomenigitis, subacute, focal, mild, leptomeninges of the brain.
16. Conjunctivitis, focal, subacute, mild, conjunctiva.
17. Concretions, multiple, moderate, lacrimal gland.

30 April 1970

Necropsy No. M-3-70 (AFIP Accession 1349638)

### Gross Findings

This female mink, R-636, from the control group died on 27 April 1970 and was refrigerated until examined.

There were no external scars, wounds, or abrasions or signs of cutaneous tumors. The external abnormality was that the hair around the anus was slightly soiled. The weight of this mink was 820 gm, the animal was moderately rigid, and there was a moderate amount of postmortem decomposition. On primary incision there were no evidences of trauma. The position and relationship of abdominal viscera were within normal limits.

When the thoracic cavity was opened a fairly flocculent, purulent exudate came from the left pleural space. It was evident that this exudate had been there for a considerable period of time. There was displacement of the thoracic viscera to the right side as a result of the fluid in the left side. Since the animal had been dead for some time, bacteriologic samples were not taken. There did not appear to be an active pneumonia in the lungs, but there was a fibrinopurulent exudate over the lobes of the left lung.

The heart was within normal limits and weighed about 8 gm.

The spleen appeared to be enlarged and weighed 13.9 gm.

The liver was a normal bronze color and appeared to be within normal limits. There was a moderate degree of imbibition of bile into the liver adjacent to the gallbladder.

The adrenals weighed 165 mg and appeared to be within normal limits. There were no visible lesions in the pancreas, thyroids, or pituitary. The parathyroids and pineal body were not visualized.

The only contents of the gastrointestinal tract consisted of about 2 to 3 ml of a reddish flocculent material in the stomach. On closer examination small punctate erosions measuring less than 0.5 mm in diameter were seen in the mucosa of the stomach. There appeared to be approximately 8 to 10 of these. There were no lesions in the intestinal tract, and no parasites were seen.

No lesions were seen in the kidneys or the rest of the urinary system. The urinary bladder was contracted and small and was not opened.

Examination of the genital system revealed that the mink was pregnant, and there were six fetuses measuring approximately 1.5 cm, crown to rump.

There were no lesions seen about the head. The brain appeared to be reddened, and the meningeal vessels were prominent.

A femur was saved in formalin for subsequent examination of bone marrow if required. A number of articulations were examined, but no lesions were visible.

---

#### Weights

---

Body	820 gm
Heart	8.0 gm
Lungs	15.7 gm
Liver	34.7 gm
Kidneys	7.2 gm
Spleen	13.9 gm
Brain	8.3 gm
Adrenals	165.0 mg

---

Impressions: Cause of death in this animal was an extensive fibrinopurulent, unilateral pleuritis of undetermined etiology.

#### Microscopic Findings

##### Diagnoses:

1. Pleuritis, fibrinopurulent, diffuse, severe, left lung, mink.
2. Hemorrhage, focal, moderate, lung.
3. Epicarditis, fibrinopurulent, focal, moderate, heart.
4. Myocarditis, focal, subacute, heart.
5. Extramedullary hematopoiesis, diffuse, moderate, spleen.
6. Plasmacytosis, diffuse, mild, tubular epithelium of the kidney.
7. Fatty metamorphosis, diffuse, mild, tubular epithelium of the kidney.
8. Pyelitis, focal, mild, pelvis of kidney.
9. Erosion, focal, mild, gastric mucosa.
10. Hemorrhage, diffuse, mild to moderate, lymph nodes.
11. Lymphoid depletion, diffuse, severe, lymph node.

30 April 1970

Necropsy No, M-4-70 (AFIP Accession 1349639)

#### Gross Findings

This female mink, R-326, was from the simulator site. Date of death was 28 April 1970.

Weight of this animal was 520 gm. It was in the state of moderate rigidity and had undergone moderate postmortem decomposition. There was a 5-cm abraded area on the left flank and upper thigh, and the area was covered with a scab. There was a moderate amount of soiling of the hair around the anus. There were no other external lesions.

On primary incision there were no evidences of trauma in the subcutaneous fat, muscles, etc. The position and relationship of the abdominal viscera were within normal limits. No lesions were observed in the thoracic cavity on primary incision.

On examination of the respiratory tract the lungs weighed 9.1 gm and showed no visible lesions.

The heart weighed 5.1 gm and appeared to be within normal limits. There were no lesions in the aorta.

The spleen weighed 4.2 gm and appeared to be small in relation to the other animals seen on 30 April 1970. There was a scar traversing the last centimeter of the spleen that appeared to be the result of traumatic injury.

The liver had a bright yellow color, and the architecture was quite clearly delineated. Grossly it appeared to be quite fatty. The liver weighed 57.8 gm.

The adrenal glands weighed 170 mg and appeared to be within normal limits. There were no lesions of the pancreas, thyroid, or pituitary. The parathyroids and pineal body were not observed.

The gastrointestinal contents were minimal except for the stomach, which contained about 2 to 3 ml of reddish-brown flocculent material, presumably coagulated blood. There were a number of erosions scattered through the mucosa of the stomach measuring up to about 2 mm in diameter. A considerable amount of coagulated blood was adherent to the mucosa of the stomach. There was evidence of black, tarry material down through the length of the intestine and appearing as large globules of material in the rectum.

The kidneys appeared to be enlarged. They were grayish brown and swollen. They weighed 12.2 gm. On longitudinal sectioning of

these kidneys, a hemorrhagic infarct was seen at the pole of one kidney, and smaller infarcts were seen in the cortex of both kidneys. The urinary bladder was small and contracted and was not opened.

The uterus was small in this animal and showed no evidence of pregnancy.

There were no visible lesions around the head of the animal. This included the ears, salivary glands, and leptominges. The brain showed no gross lesions.

A femur was kept for subsequent bone marrow examination if necessary.

---

#### Weights

---

Body	520 gm
Heart	5.1 gm
Lungs	9.1 gm
Liver	57.8 gm
Kidneys	12.2 gm
Spleen	4.2 gm
Brain	7.2 gm
Adrenals	170 mg

---

Impressions: The cause of the fatty change in the liver was unknown. The renal infarcts were probably due to septic emboli of unknown origin. Cause of death was probably an unidentified bacterial agent.

#### Microscopic Findings

##### Diagnoses:

1. Infarction, renal, multiple, severe, kidney, mink.
2. Infarction, splenic, focal, severe, spleen.
3. Infarction, myocardial, subacute, focal, moderate, heart.
4. Fatty metamorphosis, diffuse, severe, liver and kidney.
5. Erosions, gastric, multiple, focal, moderate, stomach.
6. Pleuritis, multifocal, acute, mild, lung.
7. Osseous heteroplasia, focal, minimal, lung, mink.
8. Wound, healing, focal, skin.

1 May 1970

Necropsy No. M-5-70 (AFIP Accession 1349640)

### Gross Findings

This female mink, R-178, was from the test site. The animal had been in a declining condition of health for the previous few days and had been passing black tarry feces. She was brought in from the test site at 1200 hours. One ml of sodium pentobarbital (Somnopentyl Pitman-Moore)\* was given, and several drops of blood ran out when the needle was pulled from the peritoneal cavity. The body weight of this mink was 750 gm. The animal was limp, and there was no postmortem decomposition.

On external examination a large area of the hair around the anus and rear quarters was wet and matted. The origin of the discharges was uncertain at this time. There were no cutaneous tumors, bony exostotic growths, or malformations.

On primary incision there was no evidence of trauma. The position and relationship of the abdominal viscera were within normal limits. There was about 2 ml of freshly clotted blood in the peritoneal cavity. When the thorax was opened no pleural adhesions were seen or any gross evidence of pleuritis.

On examination of the respiratory tract no evidences of pneumonia in the lungs nor any gross lesions were seen.

The heart weighed 6.0 gm and had the normal shape and weight.

The spleen appeared to be enlarged and weighed approximately 15.3 gm; approximately 1 gm of this was saved for virologic studies. It had the normal color but was fairly moist on cross section.

The liver appeared to be normal with the exception of the intermediate lobe, which was of about the same firmness as the rest of the liver but was quite reddened, with 2-to 3-mm reddish spots scattered over the surface; reddish, cystlike spaces were present on cross section. When the intermediate lobe was incised, blood exuded. The liver weighed 42.6 gm. There were no lesions in the gallbladder.

It is not possible to take an accurate weight of the adrenal glands. What was recognized of the left adrenal weighed approximately 50 mg,

---

\*Trade names and company names are used in this publication solely to provide specific information. Mention of a trade name or company names does not constitute a guarantee or warranty of them by the U.S. Air Force or Department of Defense or an endorsement by the Department over those not mentioned.

while on the right side there was a mass in the position where the adrenal would ordinarily be expected; this mass weighed approximately 730 mg and included a portion of the abdominal aorta. There were no lesions of the thyroids, pancreas, or the pituitary. The parathyroids and pineal body were not seen. A lymph node near the left thyroid was greatly enlarged and weighed 701 mg, while the right seemed quite small and weighed about 135 mg. The left node was reddened and enlarged but otherwise unremarkable.

There were no gross lesions in the gastrointestinal tract.

The kidney seemed to be lighter in color than normal, and there were red petechiae and streaks in the medulla. The weight of the combined kidneys was 9.4 gm. The urinary bladder appeared to be enlarged and collapsed rather than contracted, but no urinary calculi were recognized. The entire pelvic viscera was dissected and placed in formalin, including the scent glands.

On examination of the uterus there was evidence of six implantation sites, appearing as enlargements in the uterus, three on each side. When these were incised there was a reddish-gray exudate. A sample of this material was taken for bacteriologic examination. (This may have accounted for some of the exudate on the hind quarters).

Examination of the head and brain revealed no gross lesions.

A femur was retained for future studies of bone marrow if indicated. A block of tissue including lumbar vertebrae was also retained. This particular area of the lumbar region contained a sublumbar abscess from which there was a reddish-gray exudate similar to that seen in the uterus. A sample of this exudate was also taken for bacteriologic examination. Several articulations were examined, and no gross lesions were seen.

Samples of the liver and spleen were taken for virologic analysis at Washington State University.

---

## Weights

---

Body	750 gm
Heart	6.0 gm
Lungs	6.6 gm
Liver	42.6 gm
Kidneys	9.4 gm
Spleen	15.3 gm
Brain	7.6 gm
Left adrenal	50 mg
Right adrenal	730 mg
Lymph node near left thyroid	701 mg
Lymph node near right thyroid	135 mg

---

The prescapular lymph nodes were greatly enlarged and red, as were the visceral lymph nodes in the abdominal cavity.

Impressions: Death was probably related to the sublumbar abscess and possibly to the uterine lesions.

### Microscopic Findings

#### Diagnoses:

1. Endometritis, diffuse, moderate to severe, subacute to chronic, uterus, mink.
2. Thrombosis and infarction, diffuse, severe, intermediate lobe of liver.
3. Pachymeningitis, diffuse, acute, severe, lumbar area.
4. Osteitis, acute, focal, moderate, lumbar vertebrae.
5. Abscess, unencapsulated, severe, sublumbar area.
6. Hemorrhage, diffuse, severe, visceral lymph node.
7. Pyelonephritis, chronic, diffuse, moderate, kidney.
8. Plasmacytosis, diffuse, moderate, lymph node.
9. Urethritis, subacute, focal, mild, pelvic urethra.
10. Myocarditis, interstitial, focal, mild, heart.
11. Hepatitis, subacute, focal, mild, liver.
12. Hyperplasia, cystic, focal, mild, gallbladder.
13. Erythrophagocytosis, diffuse, moderate, lymph node.
14. Phlebitis, lymphangitis, steatitis, acute, diffuse, mild, omentum and mesentery.
15. Lymphadenitis, diffuse, acute, severe, pancreatic lymph node.
16. Serositis, subacute, diffuse, mild to moderate, peritoneum.
17. Adenitis, focal, acute, severe, scent gland.

1 May 1970

Necropsy No. M-6-70 (AFIP Accession 1349641)

### Gross Findings

This female mink, R-426, was from the simulator site. The animal had recently been in a progressively deteriorating state of health, with increasing difficulty in breathing, and was thought to be near death. At approximately 1300 hours she was given an injection of penicillin. Later, however, it was determined that she should be examined on this date, and she was then given 1 ml of Sennopentyl intraperitoneally.

The body weight of this mink was 974 gm. The body was in relatively good condition and had a considerable amount of subcutaneous fat. She was limp, and there was no postmortem decomposition. Virologic samples were taken of the liver, spleen, and lungs, as well as the pleural fluid. There were no scars, wounds, or abrasions on the body, but there was a mild amount of soiling of the posterior portion around the anus.

On primary incision there was no evidence of trauma in the subcutaneous fat or muscle. The position and relationship of the abdominal viscera were within normal limits. When the thorax was opened, a serous, white flocculent material exuded from the thoracic cavity.

On examination of the respiratory system there was approximately 78 ml of the exudate in the pleural space bilaterally; it did not involve the pericardial space. The pleural surface of the lungs and the thorax seemed to be thickened by a fibrinous type of exudate, but the lungs themselves did not appear to be pneumonic.

The heart was within normal limits as to shape and relative size. Its weight was 6.0 gm.

The spleen weighed 21.2 gm (possibly the effect of sodium pentobarbital). The spleen had a normal color but was congested and moist on cut surface. The liver was slightly yellow and had mild accentuation of the architectural markings. The liver weighed 45.4 gm. There were no lesions of the gallbladder or the bile ducts.

The weight of the adrenal glands was 155 mg. There were no lesions of the pancreas, adrenals, thyroids, or pituitary. The parathyroids and pineal body were not visualized.

On examination of the gastrointestinal tract there was a mild amount of blackish flocculent material in the stomach and upper intestine. The gastric mucosa had a few very small punctate erosions less than 1 mm in diameter.

The kidneys weighed 7,0 gm and were of a normal color and consistency. The urinary bladder was slightly distended and empty. No lesions were seen in the bladder or the urethra.

The uterus contained six fetuses measuring approximately 2 cm from crown to rump.

On examining the head there were no lesions around the ears, salivary glands, and scalp. There were no gross lesions of the brain.

A femur was saved for possible future bone marrow examination.

---

#### Weights

---

Body	974 gm
Heart	6.0 gm
Lungs	13,8 gm
Liver	45.4 gm
Kidneys	7,0 gm
Spleen	21.2 gm
Brain	6.3 gm
Adrenals	155 mg

---

Impressions: Cause of declining state of health was related to the severe seropurulent pleuritis.

#### Microscopic Findings

##### Diagnoses:

1. Pleuritis, fibrinopurulent, diffuse, severe, lung, mink.
2. Heteroplastic bone, focal, mild, lung.
3. Lymphoid depletion, moderate, hilar lymph node.
4. Plasmacytosis, diffuse, mild, hilar lymph node.
5. Hemorrhage, focal, mild, lung.
6. Lymphadenitis, diffuse, severe, peritracheal lymph node.
7. Pericholangitis, subacute, focal, mild, liver.
8. Extramedullary hematopoiesis, diffuse, severe, spleen.
9. Pyelonephritis, multifocal, subacute, moderate, kidney.
10. Erosions, focal, mild, mucosa of the stomach.
11. Hemorrhage and erythrophagocytosis, diffuse, moderate, lymph node.
12. Plasmacytosis, diffuse, moderate, lymph node.
13. Lymphoid depletion, diffuse, severe, follicles of lymph nodes.
14. Adenitis, subacute, multifocal, moderate, adrenal glands.
15. Meningitis, multifocal, mild, brain

4 May 1970

Necropsy No. M-7-70 (AFIP Accession 1349642)

#### Gross Findings

This female mink, R-44, was from the test site. She had not eaten for 4 days, and had labored breathing during the past 24 hours. The animal was killed with 0.75 ml of sodium pentobarbital intraperitoneally. The body weight of the mink was 900 gm. The animal was limp, and there was no postmortem decomposition. No external scars, wounds, or abrasions were seen. The rear quarters around the anus were somewhat soiled.

On primary incision there was no evidence of trauma, and there was a fair amount of subcutaneous fat. The position and relationship of the abdominal viscera were within normal limits, and there was very little peritoneal fluid. When the thorax was opened there was an excessive amount (61 ml) of fibrinopurulent exudate present bilaterally. The lungs were partially collapsed.

Examination of the respiratory tract revealed focal raised yellow areas measuring approximately 0.5 to 0.8 cm scattered over the surface of the lungs. There were approximately six of these lesions. One of them was excised for bacteriologic analysis. The lungs weighed 10.7 gm.

In the heart no gross lesions were seen, and the pericardial space contained clear serous fluid appearing normal in color and consistency. There were no lesions in the aorta. The heart weighed 4.5 gm.

The spleen weighed 6.5 gm and seemed to be enlarged, but the color was within normal limits, and the cut surface was moist.

The liver weighed 31.1 gm, was light tan, and contained no gross lesions. The gallbladder and bile ducts showed no gross lesions.

The weight of the adrenal glands was 158 mg, and the thyroids weighed 93 mg; there were no gross lesions. The pancreas appeared to be larger than those seen previously, but there were no gross lesions. Nor were there gross lesions in the pituitary. The parathyroids and pineal body were not visualized.

On examining the gastrointestinal tract no gross lesions or parasites were seen. There were, however, some feces, firm in consistency, in the terminal portion of the colon,

The weight of the kidneys was 7.0 gm, and there were no gross lesions in the urinary system.

In the uterus were six fetuses that measured approximately 5 cm, crown to rump. Two of these were saved for virologic examination.

No gross lesions of the head were seen, nor of the brain when removed.

A femur was saved for subsequent bone marrow examination if deemed necessary. A number of articulations were examined, and none had gross lesions.

Note: Virologic samples included liver, spleen, pleural fluid, and lung. Bacteriologic samples included pleural fluid.

---

#### Weights

---

Body	900 gm
Heart	4.5 gm
Lungs	10.7 gm
Liver	31.1 gm
Kidneys	7.0 gm
Spleen	6.5 gm
Brain	7.7 gm
Adrenals	158 mg
Thyroids	93 mg
Pleural exudate	61 ml

---

Impression: Declining state of health was related to the severe fibrinopurulent pleuritis.

#### Microscopic Findings

Diagnoses:

1. Pleuritis, chronic, severe, lung, mink.
2. Pneumonia, purulent, focal, moderate, lung.
3. Lymphadenitis, diffuse, subacute, hilar lymph node.
4. Edema, diffuse, moderate, peritracheal lymph node.
5. Epicarditis, fibrinopurulent, subacute, focal, moderate, heart.
6. Extramedullary hematopoiesis, diffuse, severe, spleen.
7. Vacuolization, diffuse, moderate, tubular epithelium of the kidney.
8. Vacuolization, diffuse, mild, liver.
9. Ectopic pancreatic tissue, focal, mild, epithelium of the gallbladder.

6 May 1970

Necropsy No. M-13-70 (AFIP Accession 1349645)

### Gross Findings

This black female mink, B-110, was not part of the primary sonic-boom experiment but was used to demonstrate a necropsy procedure.

The animal was observed dead in its cage in the morning and had not had any prior signs of illness. The body weighed 1.2 kg, appeared to be in good condition, was in a moderate state of rigidity, and had only a slight amount of postmortem decomposition. There were no scars, wounds, or abrasions visible on the surface of the animal.

On primary incision there was no evidence of trauma. The peritoneal cavity had a moderate amount of blood-tinged fluid (approximately 1 to 2 ml).

In the respiratory tract there were a few small subpleural hemorrhages scattered over the surface of the lung.

The heart was within the normal range of shape and size. There were no lesions in the aorta.

The spleen appeared to be large but was otherwise unremarkable.

The liver was tan but was not swollen, nor did it contain visible gross lesions.

Of the endocrine glands, there were no lesions in the pancreas, adrenals, thyroids, or pituitary. The parathyroids and pineal body were not visualized.

On examination of the gastrointestinal tract a small amount of dark, flocculent material was seen in the stomach, and small (less than 0.1 cm), punctate erosions were seen in the mucosa of the stomach. There were no other lesions in the gastrointestinal tract.

No gross lesions were seen in the urinary system.

On examination of the genital system six mature fetuses were found in the uterus, three on each side. The fetal portion of the placentome was easily detached from the uterus, and there was a moderate amount of bloody fluid in the lumen of the uterus. The myometrium was red and flaccid.

There were no gross lesions in the region of the head or in the brain.

A femur was not saved for bone-marrow examination. Several articulations were examined, and no gross lesions were seen.

Organ weights were not taken.

Impression: This animal probably died as a result of problems arising during the whelping process.

#### Microscopic Findings

#### Diagnoses:

1. Necrosis, focal, acute, severe, myometrium of the uterus, mink.
2. Congestion, hemorrhage, and edema, mild to moderate, uterus,
3. Hepatitis, necrotizing, focal disseminated, moderate, liver, cause undetermined.
4. Heteroplastic bone, focal, mild, lung.
5. Pneumonitis, acute, focal, mild, lung.
6. Hemorrhage, interstitial, moderate, pancreas.
7. Hemorrhage, diffuse, moderate, pancreatic lymph node.
8. Extramedullary hematopoiesis, diffuse, severe, spleen.
9. Necrosis and hemorrhage, focal, mild, mucosa of stomach.

10 May 1970

Necropsy No. M-62-70 (AFIP Accession 1349660)

### Gross Findings

This female mink, RA-90, was from the test site. The animal was found dead in her cage in the morning. The cause of death was thought to be related to whelping. The body weight was 1.1 kg. The condition of the animal was good, she was in a moderate state of rigidity, and there was very little postmortem decomposition. There was a wound and scab on the skin of the left mandible approximately 1 cm from the symphysis. The only other external sign was soiling of the rear quarters with a fluid resembling serum.

On primary incision there was no evidence of trauma in the subcutaneous fat, muscles, peritoneum, or the skeleton. The position and relationships of the abdominal viscera were within normal limits. The greatly distended, reddened uterus was quite obvious on opening the peritoneal cavity.

Examination of the respiratory tract revealed slight reddening of one lobe of the lung. The lungs were infused with approximately 18 ml of formalin fixative. They weighed 11.1 gm.

The heart was within normal range of shape and size. It weighed 7.3 gm. There were no lesions in the aorta.

The spleen appeared to be enlarged and weighed 17.3 gm, was of normal color, and had a moist cut surface.

The liver weighed 42.0 gm. It was light tan but did not appear to be swollen. There were no lesions in the gallbladder or bile ducts.

The adrenal glands weighed 94 mg. The left adrenal gland appeared to be in small nodular parts 1 to 2 mm in diameter. The thyroids weighed 72 mg. There were no lesions in the pancreas, thyroids, or pituitary. The parathyroids and pineal body were not visualized.

On examination of the gastrointestinal tract, there was about 2 ml of mucus-like fluid in the stomach. No other lesions were seen in the GI tract.

The weight of the kidneys was 7.2 gm. The urinary bladder was quite reddened on the external surface; it was contracted and did not contain urinary calculi. The pelvic viscera were removed en masse.

Upon examination of the genital system the uterus was found to be greatly distended, but it was devoid of the usual periferetal fluids, which had presumably already been expelled. There were two large fetuses on the right horn, the one nearest the bifurcation being curled up in the fetal position. The fetuses in the left horn were smaller, and the

one nearest the bifurcation was headed into the bifurcation in a posterior-first delivery. The hind quarters of this fetus seemed to be lodged in the body of the uterus. The second fetus on the left side was small and quite hemorrhagic. The third fetus looked normal. The lining of the vagina appeared to be reddened and had a serous, tenacious exudate adhering to it.

On examining the head no lesions were found except for the wound on the skin of the mandible. The brain appeared to be slightly reddened; otherwise there were no gross lesions.

A femur was taken for examination of bone marrow if required. Several articulations were examined, and no gross lesions were seen.

---

#### Weights

---

Body	1,100 gm
Heart	7.3 gm
Lungs	11.1 gm
Liver	42.0 gm
Kidneys	7.2 gm
Spleen	17.3 gm
Brain	7.3 gm
Adrenals	94 mg
Thyroids	72 mg

---

Impression: Death was related to problems arising during the whelping process.

#### Microscopic Findings

##### Diagnoses:

1. Endometritis, necrotic, subacute, severe, uterus, mink.
2. Metritis, subacute, diffuse, severe, uterus.
3. Postmortem degeneration, diffuse, moderate, fetus.
4. Congestion, hemorrhage, and edema, focal, mild, lung.
5. Pigment, granular, brown, mild, hilar lymph node.
6. Hemorrhage and erythrophagocytosis, focal, mild, hilar lymph node.
7. Pericholangitis, subacute, mild, liver.
8. Extramedullary hematopoiesis, diffuse, moderate, spleen.
9. Glossitis, subacute, focal, mild, tongue.
10. Hemorrhage, diffuse, moderate, lymph nodes.
11. Lymphadenitis, subacute, moderate, mandibular lymph node, due to unidentified bacteria.

11 May 1970

Necropsy No. M-135-70 (AFIP Accession 1349677)

### Gross Findings

This mink, R-266, whelped during the preceding 24 hours. Some of her kits were picked up prior to the sonic booms at the boom test site on this day, and one dead kit and a placenta was picked up following the booms. She was killed with 1 ml of Somnopentyl for the collection of virologic samples to be shipped to Washington State University.

The body weight was 1.2 kg. She was in good condition and limp; there was no postmortem decomposition.

There was a wound posterior and inferior to the left eye that appeared to be an old lanced abscess that was still draining. There were no cutaneous tumors or bony exostotic growths. The rear quarters around the tailhead were soiled with a partially dried serous exudate.

On primary incision there was no evidence of trauma. The position and relationship of abdominal viscera were within normal limits.

On examination of the respiratory tract there were no gross lesions. The lungs were infused with formalin solution.

The heart weighed 6.9 gm and was within normal limits. The aorta showed no gross lesions.

The spleen weighed 7.8 gm and was congested; blood ran from the cut surface.

The liver was tan but did not appear to be swollen, nor did it have gross lesions. The gallbladder was without gross lesions.

Of the endocrine glands, the adrenals weighed 95 mg, the thyroids weighed 75 mg, and there were no lesions in the pancreas, adrenals, thyroids or pituitary; the parathyroids and pineal body were not visualized.

On examination of the gastrointestinal tract no gross lesions were seen.

There were no gross lesions of the urinary system.

On examination of the genital system the uterus was found to be enlarged, congested, and dark; the mucosal surface appeared to be necrotic and had a minimal amount of exudate clinging to the mucosal surface. A portion of the uterus was excised for bacteriologic studies.

On examining the head no gross lesions were seen other than the lanced abscess mentioned above.

There were no gross lesions in the brain.

A femur was saved for subsequent bone marrow examination if deemed necessary. Several articulations were examined, and there were no gross lesions.

---

#### Weights

---

Body	1,200 gm
Heart	6.9 gm
Lungs	7.5 gm
Liver	31.5 gm
Kidneys	5.8 gm
Spleen	7.8 gm
Brain	7.4 gm
Adrenals	95 mg
Thyroids	75 mg

---

Impressions: There were no outstanding gross lesions.

#### Microscopic Findings

##### Diagnoses:

1. Cholecystitis, diffuse, subacute, moderate, gallbladder, mink.
2. Hemorrhage, focal, mild, lung.
3. Extramedullary hematopoiesis, diffuse, moderate, spleen.
4. Urethritis, subacute, focal mild, pelvic urethra.
5. Wound, healing, skin.
6. Ectopic pancreatic tissue, focal, mild, epithelium of the gallbladder.

11 May 1970

Necropsy No. M-190-70 (AFIP Accession 1349682)

### Gross Findings

This female control mink, R-610, whelped on 4 May 1970. One dead kit was picked up on 9 May 1970, and there were five dead kits in the nesting box on 10 May 1970. The caretaker noted blood in the nesting box on 10 May 1970. This mink was killed with 1 ml of Somnopentyl for virologic samples to be sent to Washington State University and bacteriologic samples to be processed at USAF SAM. The weight of the mink was 920 gm. Her condition was good, she was limp, and there was no postmortem decomposition. There were no scars, wounds, or abrasions over the surface of the body. There was a slight amount of soiling of the hind quarters around the tailhead with a serous, partially dried fluid.

On primary incision there was no evidence of trauma.

There were no gross lesions of the respiratory tract.

The heart was within normal limits of shape and relative size, although its weight was only 3.9 gm. A sample of heart blood was withdrawn at the time of necropsy. There were no lesions in the aorta.

The spleen was enlarged, congested, and reddened; it weighed 10.0 gm and was moist on cut surface.

The liver was tan but did not appear to be swollen. It weighed 30.3 gm. There were no lesions in the gallbladder or the bile ducts.

The adrenal glands weighed 106 mg, and the thyroids weighed 76 mg. There were no lesions in the pancreas, adrenals, thyroids, or pituitary gland. The parathyroids and pineal body were not visualized.

On examination of the gastrointestinal tract there was approximately 4 gm of feed in the stomach, and there were traces of feces throughout the intestinal tract. There were no gross lesions.

There were no gross lesions of the urinary system. A sample of urine was taken from the urinary bladder at the time of necropsy for bacteriologic examination

The left horn of the uterus was taken for bacteriologic examination. The right horn was enlarged at the ovarian end, and when it was incised, placental remnants were found. In this same area there were also adhesions of the uterus to the omentum.

On examining the head there were no gross lesions, nor were there any in the brain.

Examination of the bone marrow will be done subsequently if indicated on a femur that was placed in the formalin fixative. Several articulations were examined, and there were no gross lesions.

Portions of the liver and spleen were taken for virologic examination.

---

#### Weights

---

Body	920 gm
Heart	3,9 gm
Lungs	7,5 gm
Liver	30,3 gm
Kidneys	4,6 gm
Spleen	10,0 gm
Brain	5,6 gm
Adrenals	106 mg
Thyroids	76 mg

---

Impression: The only gross lesion of importance consisted of the remnants of the retained placenta. It is unknown whether this would have caused the death of the mink eventually.

#### Miscroscopic Findings

##### Diagnoses:

1. Metritis, necrotic, regional, severe, uterus, mink.
2. Endometritis, purulent, focal, moderate, uterus.
3. Retained placenta, focal, uterine horn.
4. Hemorrhage, diffuse, moderate, submucosa of the vagina.
5. Extramedullary hematopoiesis, diffuse, moderate, spleen.
6. Vacuolization, diffuse, mild, tubular epithelium of the kidney.

Necropsy No. M-191-70 (AFIP Accession 1349683)

#### Gross Findings

This female mink, R-318, was from the simulator site. The animal was killed for virologic samples to be sent to Washington State University and bacteriologic samples to be sent to USAF School of Aerospace Medicine (SAM), Brooks AFB, Texas. This animal was killed with 1.0 ml of Somnopentyl given intraperitoneally. The weight of the animal was 1.05 kg; she was limp, and there was no postmortem decomposition. There were no external scars, wounds, or abrasions.

On primary incision there was no evidence of trauma in the soft tissues or the skeleton.

On examination of the respiratory tract there were no gross lesions. The lungs weighed 7.3 gm and were infused with formalin.

The heart was of normal shape and relative size and weighed 5.8 gm. There were no lesions in the aorta.

The spleen was enlarged and congested and weighed approximately 11.5 gm. Blood ran from the cut surface.

The liver was tan and not swollen. It weighed 31.7 gm. There were no lesions in the gallbladder or the bile ducts.

Of the endocrine glands, the adrenals weighed 110 mg, and the thyroids 65 mg. There was an apparent difference in the size of the thyroids, the right one being much smaller than the left. There were no lesions of the pancreas, adrenals, or pituitary; the parathyroids and pineal body were not visualized.

On examination of the gastrointestinal tract there was approximately 1 gm of food in the stomach, with no gross lesions throughout the gastrointestinal tract.

There were no gross lesions of the urinary system.

On examination of the genital system the uterus was slightly congested and still thickened following parturition approximately 2 days previously. The mucosa of the uterus was reddened and had a necrotic appearance with a small amount of clotted blood in the lumen.

There were no gross lesions of the head nor of the brain.

A femur was saved for subsequent bone marrow examination if deemed necessary. Several articulations were examined, and no gross lesions were seen.

Samples of blood, liver, and spleen were saved for virologic examinations at Washington State University. A blood sample and the left horn of the uterus were saved for bacteriologic examination at USAF SAM.

---

### Weights

---

Body	1,050 gm
Heart	5.8 gm
Lungs	7.3 gm
Liver	31.7 gm
Kidneys	6.3 gm
Spleen	11.5 gm
Brain	7.8 gm
Adrenals	110 mg
Thyroids	65 mg

---

Impression: There were no outstanding gross lesions. The uterus was probably in a normal involutionary stage.

### Microscopic Findings

#### Diagnoses:

1. Metritis, purulent, diffuse, moderate, involuting uterus, mink.
2. Adenitis, purulent, focal, severe, scent glands.
3. Normal tissue, actively secreting mammary gland.
4. Congestion and edema, interstitial, focal, mild, lung.
5. Hepatitis, subacute, focal, mild, liver.
6. Hyperplasia, diffuse, mild, epithelium of bile ducts.
7. Vacuolization, diffuse, moderate, tubular epithelium of kidney, probably fat.
8. Extramedullary hematopoiesis, diffuse, moderate, spleen.

12 May 1970

Necropsy No. M-230-70 (AFIP Accession 1349685)

### Gross Findings

This female mink, R-456, was a control animal. She was killed with 1.0 ml. of Somnopentyl given intraperitoneally, for virologic and bacteriologic samples for Washington State University and USAF School of Aerospace Medicine, Brooks Air Force Base, Texas. She whelped in the night of 10 May 1970, and five dead kits were picked up on 11 May 1970 and two live ones remained. The two live kits were killed for virologic examination at Washington State University along with the dam. This female mink was in good body condition and was limp; there was no postmortem decomposition. There were no scars, wounds, or abrasions over the surface of the body.

On primary incision there was no evidence of trauma in the subcutaneous tissues or in the skeleton.

There were no gross lesions of the respiratory tract.

The heart was within normal limits of shape, weight, and relative size. There were no lesions in the aorta.

The spleen weighed 9.2 gm, and it was enlarged, congested, and oozed with blood on the cut surface. Otherwise there were no gross lesions in the spleen.

The liver was tan and not swollen and had no gross lesions. Nor were there any gross lesions in the gallbladder or the bile ducts.

The weight of the adrenals was 130 mg and of the thyroids 62 mg. There were no gross lesions of the pancreas, adrenals, thyroids, or pituitary; the parathyroids and pineal body were not visualized.

On examination of the gastrointestinal tract approximately 3 gm of food was present in the stomach, and very little was in the remainder of the digestive tract. There were no gross lesions in the gastrointestinal tract.

There were no gross lesion of the urinary system.

On examination of the genital system, the uterus was well involuted, was only mildly reddened, and had only a slightly thickened wall. There was a small amount of blood as well as necrotic exudate in the lumen of the uterus, and the mucosa appeared to be slightly necrotic in some areas.

On examination of the head no gross lesions were seen, nor were there any in the brain.

A femur was saved for bone marrow examination if deemed necessary. Several articulations were examined, and no gross lesions were found.

---

Weights

---

Body	1,120 gm
Heart	6.1 gm
Lungs	7.6 gm
Liver	28.0 gm
Kidneys	3.6 gm
Spleen	9.2 gm
Brain	8.2 gm
Adrenals	130 mg
Thyroids	62 mg

---

Portions of the liver and spleen, and a blood sample were saved for virologic examination at Washington State University. A blood sample, a small amount of urine, and a portion of the left horn of the uterus was saved for bacteriologic examination at USAF SAM.

Impression: There were no outstanding gross lesions in this mink.

Microscopic Findings

Diagnoses:

1. Congestion and hemorrhage, focal, minimal, lung, mink.
2. Erythrophagocytosis, diffuse, minimal, hilar lymph node.
3. Hemorrhage, diffuse, mild, vagina.
4. Normal tissue, involuting uterus.
5. Cholecystitis, subacute, focal, mild, gallbladder.
6. Hemorrhage and erythrophagocytosis, diffuse, mild, mesenteric lymph nodes.
7. Extramedullary hematopoiesis, diffuse, moderate, spleen.
8. Ectopic pancreatic tissue, focal, mild, epithelium of the gallbladder.
9. Vacuolization, diffuse, moderate, kidney, probably fat.

13 May 1970

Necropsy No. M-233-70 (AFIP Accession 1349686)

### Gross Findings

This female mink, R-150, from the boom test site recently whelped four kits; two of these died the same day, and the other two were not visible the following day. She was killed because she lost her litter. Tissues were saved for virologic examination at Washington State University and for bacteriologic examination at USAF SAM. She was killed with 1 ml of Somnopentyl. The weight of this mink was 1.15 kg. She was in a moderately good condition and was limp; there was no postmortem decomposition. There were no external scars, wounds, or abrasions. Her rear quarters and tailhead were wet with partially dried serous fluid.

On primary incision there was no evidence of trauma in the soft tissues or the skeleton. The position and relationship of the abdominal viscera were within normal limits, but there was an increased amount of slightly red serous fluid in the peritoneal cavity.

On examination of the respiratory system the three lobes of the right lung were independent and not attached. The apical and the cardiac lobes contained small white foci approximately 1 mm in diameter and were irregularly congested. The diaphragmatic lobe in the right side was congested in a mosaic-type pattern. The two lobes of the left lung were clear of gross lesions. The apical lobe of the right lung was saved for bacteriologic examination at USAF SAM.

The heart was within the normal shape and relative size range, weighing 6.3 gm. There were no lesions in the aorta.

The spleen was enlarged and congested, and blood flowed from the cut surface.

The liver was quite pale (the animal bled out during the time samples were being taken for microbiologic examinations). There were no gross lesions in the liver or in the gallbladder or bile ducts.

With regard to the endocrine glands, the adrenals weighed 190 mg, the thyroids 69 mg. There were no lesions in the pancreas, adrenals, thyroids, or pituitary. The parathyroids and pineal body were not visualized.

On examination of the gastrointestinal tract there was approximately 3 gm of what appeared to be hair in a mucus matrix in the stomach. There were traces of ingesta and feces through the length of the intestine.

On examination of the urinary system there were no gross lesions. A sample of urine was taken for bacteriologic examination at USAF SAM.

Examination of the genital system revealed no gross lesions in the left horn of the uterus, which was well involuted. The right horn, however, contained remnants of a fetus and attendant placenta, portions of which protruded through the wall of the uterus near the ovarian end of that horn. There were no lesions of the ovaries.

There were no gross lesions of the head or in the brain.

A femur was retained in formalin for subsequent bone marrow examinations if necessary. Several articulations were examined, and there were no gross lesions.

---

#### Weights

---

Body	1,150 gm
Heart	6.3 gm
Lungs	9.1 gm
Liver	35.7 gm
Kidneys	7.7 gm
Spleen	12.0 gm
Brain	8.2 gm
Adrenals	190 mg
Thyroids	69 mg

---

Impression: This mink would probably have died soon because of the ruptured uterus.

#### Microscopic Findings

##### Diagnoses:

1. Metritis, purulent, multifocal, subacute, severe, uterus, mink.
2. Peritonitis, diffuse, subacute, peritoneum.
3. Vaginitis, subacute, focal, mild, vagina.
4. Urethritis, subacute, focal, moderate, pelvic urethra.
5. Adenitis, subacute, focal, mild, scent glands.
6. Congestion, hemorrhage, and edema, focal, mild, lung.
7. Heteroplastic bone, focal, mild, lung.
8. Bronchiolitis, subacute, focal, mild, bronchioles.
9. Ectopic pancreatic tissue, focal, mild, epithelium of the gallbladder.
10. Extramedullary hematopoiesis, diffuse, severe, spleen.
11. Vacuolization, diffuse, moderate, tubular epithelium of the kidney.

13 May 1970

Necropsy No, M-234-70 (AFIP Accession 1349687)

### Gross Findings

This female mink, R-198, from the boom test site delivered six kits on 10 May 1970, and three were dead the following morning. Three survived to this date, when they were killed for microbiologic studies.

The dam was given 1 ml of Somnopentyl by the intraperitoneal route. The body weight was 1.09 kg. She was in good condition and limp; there was no postmortem decomposition. There were no scars, wounds, or abrasions on the body surface.

On primary incision there was no evidence of trauma to the soft tissues or the skeleton.

On examination of the respiratory tract there were no gross lesions.

The heart was within normal relative size, shape, and weight (5.0 gm). There were no lesions in the aorta.

The spleen was enlarged and congested, and blood flowed from the cut surface.

The liver was light in color but showed no gross lesions. There were no lesions in the gallbladder or the bile ducts.

With regard to the endocrine glands, the thyroids weighed 53 mg, and the adrenals 115 mg. There were no gross lesions in the pancreas, adrenals, thyroids, or pituitary; the parathyroids and pineal body were not visualized.

In the gastrointestinal tract there was about 2 ml of dark mucous fluid in the stomach, and a small amount of ingesta and feces were seen throughout the intestine. There were no gross lesions.

The urinary tract had no gross lesions.

On examination of the genital system, the uterus was well involuted; it was nearly normal in size and had only slightly thickened walls and some focal necrosis of the mucosa.

There were no gross lesions of the head or of the brain.

A femur was retained for subsequent bone marrow examination if deemed necessary. Several articulations were examined, and there were no gross lesions.

Spleen, liver, and blood were saved for virologic studies at Washington State University. A blood sample and a portion of the right horn of the uterus was saved for bacteriologic studies at USAF SAM. One kit was saved for virologic studies, two for bacteriologic studies.

---

Weights

---

Body	1,090 gm
Heart	5.0 gm
Lungs	8.1 gm
Liver	22.5 gm
Kidneys	5.8 gm
Spleen	9.8 gm
Brain	6.1 gm
Adrenals	115 mg
Thyroids	53 mg

---

Impression: There were no outstanding gross lesions.

Microscopic Findings

Diagnoses:

1. Cholecystitis, subacute, focal, minimal, gallbladder, mink.
2. Vacuolization, diffuse, moderate, tubular epithelium of the kidney.
3. Extramedullary hematopoiesis, diffuse, severe, spleen.
4. Metritis, purulent, diffuse, mild, involuting uterus.

13 May 1970

Necropsy No. M-238-70 (AFIP Accession 1349688)

### Gross Findings

This male mink, R-211, was from the fur farm where the controls were kept. It weighed approximately 2 kg and had been having increasing respiratory distress over the past 2 to 3 days and lying in the bottom of his cage undergoing considerable dyspnea. He was killed by cervical disarticulation and immediately brought into the necropsy laboratory for examination. The animal was in good condition and limp; there was no postmortem decomposition. There were no scars, wounds, or abrasions over the surface of the body.

On primary incision there were no signs of trauma in the soft tissues or in the skeleton.

On examination of the respiratory tract there was approximately 100 ml of reddish-yellow fluid in both pleural cavities, and there appeared to be a considerable amount of fibrin attached to the lungs and to the visceral surface of the rib cage. When the lungs were inflated with approximately 60 ml of formalin fixative they appeared to be in good condition. There was, however, a considerable amount of fibrin deposited over the surface of the lungs, and there appeared to be a large mass at the posterior part of the lungs.

The heart was within normal limits of shape, weight, and relative size. There was not a fibrinopurulent response in the pericardium grossly. The aorta contained no gross lesions.

The spleen appeared to be rather large, meaty, deep red, and almost dry on cut surface.

The liver was slightly pale but contained no gross lesions. There were no gross lesions in the gallbladder or the bile ducts.

With regard to the endocrine glands, the pancreas, adrenals, thyroids, or pituitary had no gross lesions. The parathyroids and pineal body were not visualized.

There were no gross lesions in the gastrointestinal tract.

The kidneys appeared to be paler than normal and had tiny pits over the surface of the cortex and a focal blotching of grayish-yellow color. There were no gross lesions in the bladder, ureters, or urethra.

On examination of the genital system there were no gross lesions in the penis or testes.

No gross lesions of the head were seen.

On examination of the brain there was a considerable amount of hemorrhage around the base of the brain (probably caused by the cervical disarticulation). Otherwise the brain contained no gross lesions.

A femur was not saved, and joints were not examined.

Organ weights were not taken on this animal because of the time limitation.

Impression: This mink would probably have died soon because of the fibrinopurulent bilateral pleuritis.

### Microscopic Findings

#### Diagnoses:

1. Pleuritis, fibrinopurulent, diffuse, chronic, severe, lung, mink.
2. Lymphadenitis, purulent, subacute, severe, mediastinal lymph node.
3. Hemorrhage, diffuse, acute, mediastinal lymph node.
4. Pneumonitis, acute, focal, mild, lung.
5. Epicarditis, fibrinous, diffuse, mild, heart.
6. Cholecystitis, subacute, multifocal, moderate, gallbladder.
7. Vacuolization, diffuse, mild, tubular epithelium of the kidney.
8. Pyelonephritis, subacute, multifocal, moderate, kidney.
9. Extramedullary hematopoiesis, diffuse, moderate, spleen.
10. Lymphadenitis, diffuse, subacute, moderate, lymph node.
11. Lymphadenitis, diffuse, acute, mild, lymph node.
12. Hypospermia, diffuse, bilateral, testicles.
13. Epididymitis, diffuse, subacute, moderate, epididymis.
14. Hemorrhage, focal, severe, brain, probably due to cervical disarticulation.
15. Ectopic pancreatic tissue, focal, mild, epithelium of the gallbladder.

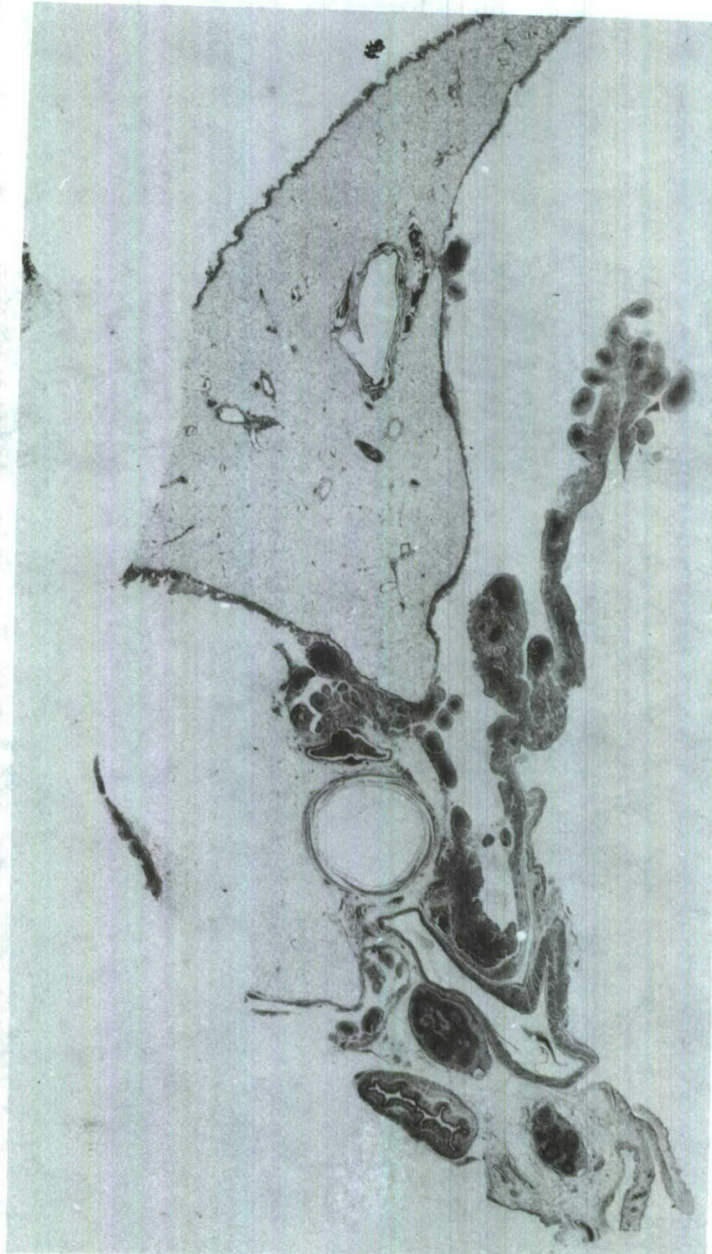

Figure 1.--Lung and mediastinum of an adult mink with severe diffuse pleuritis and no pneumonic lesions. H & E. X2. AFIP Negative 71-3733.

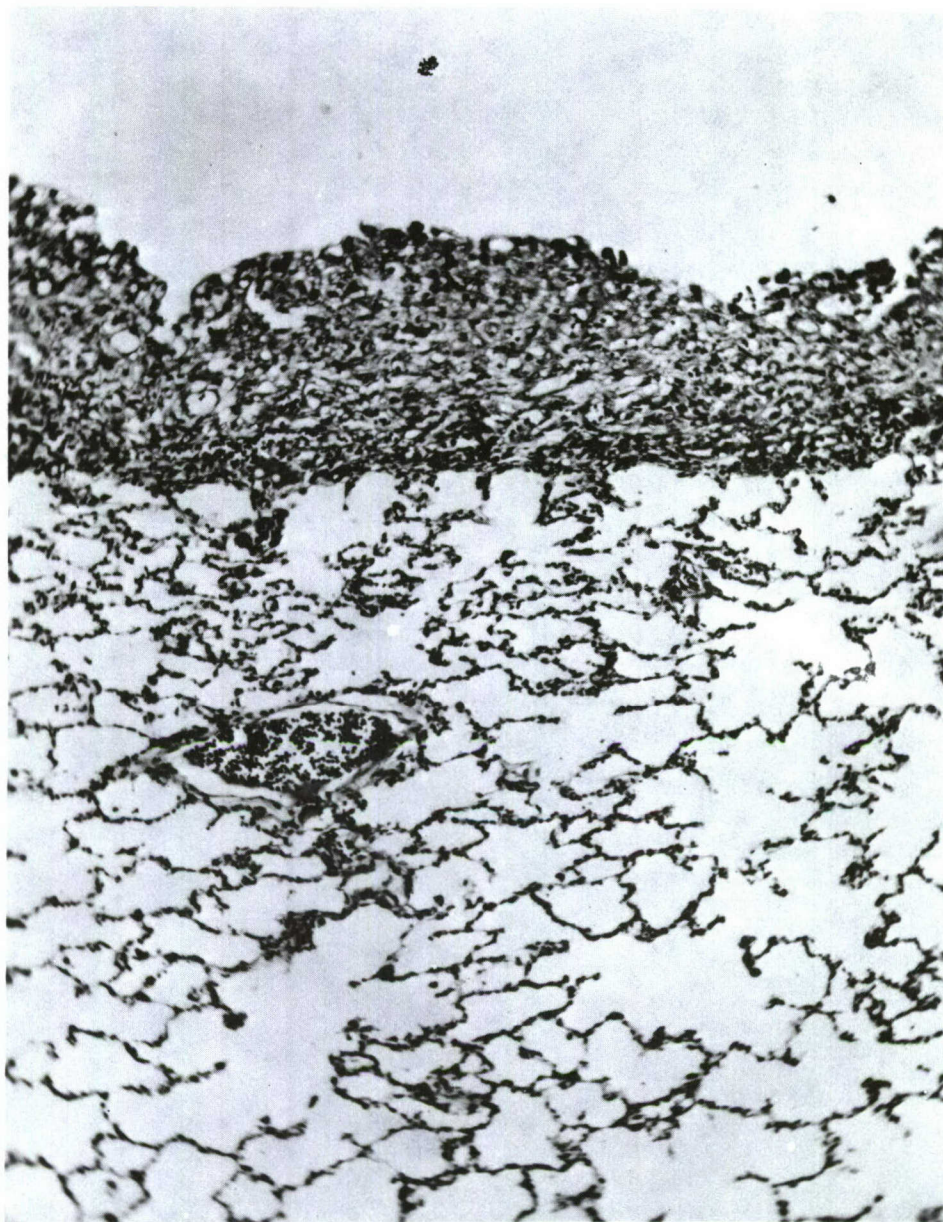

Figure 2.--Section of lung from an adult mink with chronic pleuritis and no pneumonic lesions.  
H & E. X110. AFIP Negative 70-11727.



Figure 3.--Nose of an adult mink with severe  
diffuse necrotic rhinitis.

H & E. X7.5. AFIP Negative 70-11681.



Figure 4.--Necrotic endometritis in an adult mink with a ruptured uterus. H & E. X45. AFIP Negative 70-11897.



Figure 5.--Necrotic placenta and uterus of an adult mink.  
H & E. X5. AFIP Negative 70-11706.

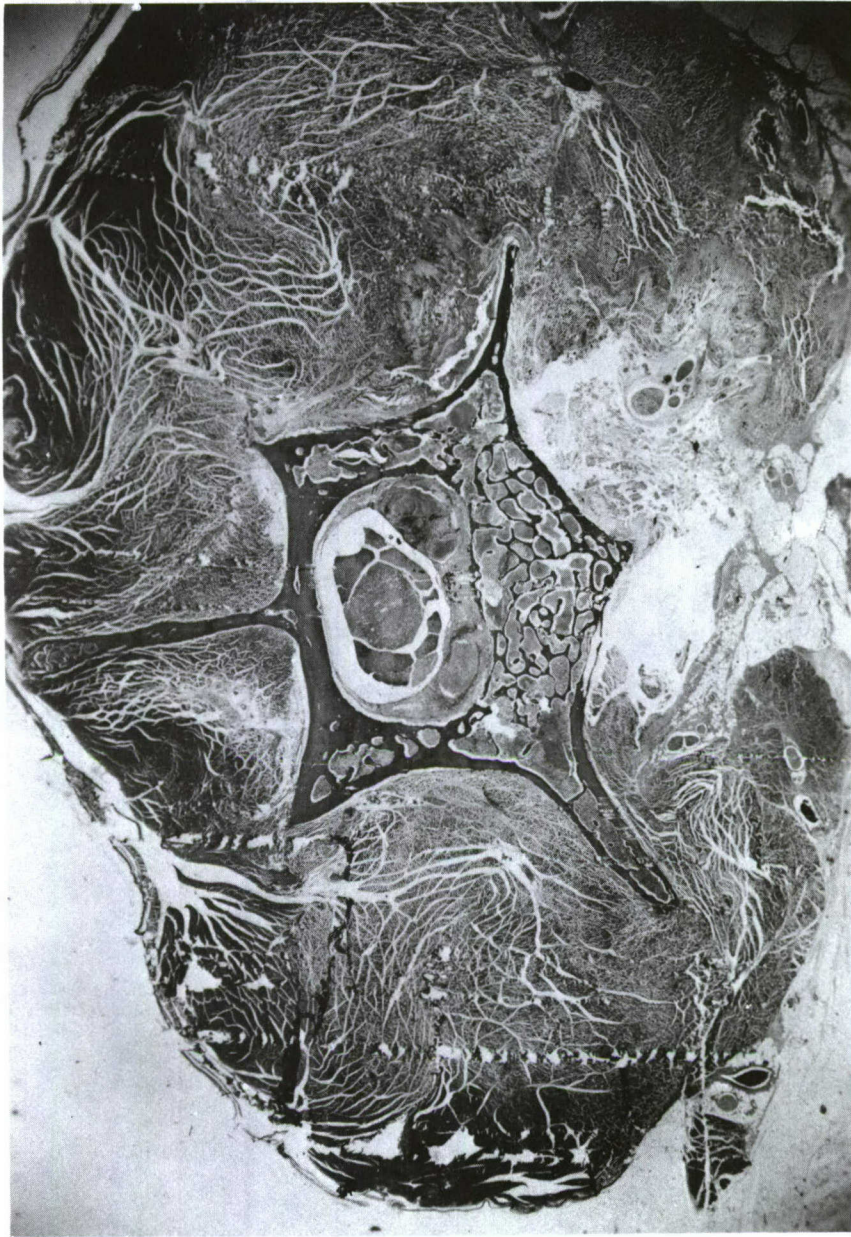

Figure 6.--Extensive sublumbar abscess, osteitis of the vertebra, and pachymeningitis in an adult mink.  
H & E. X5.5. AFIP Negative 70-11691.

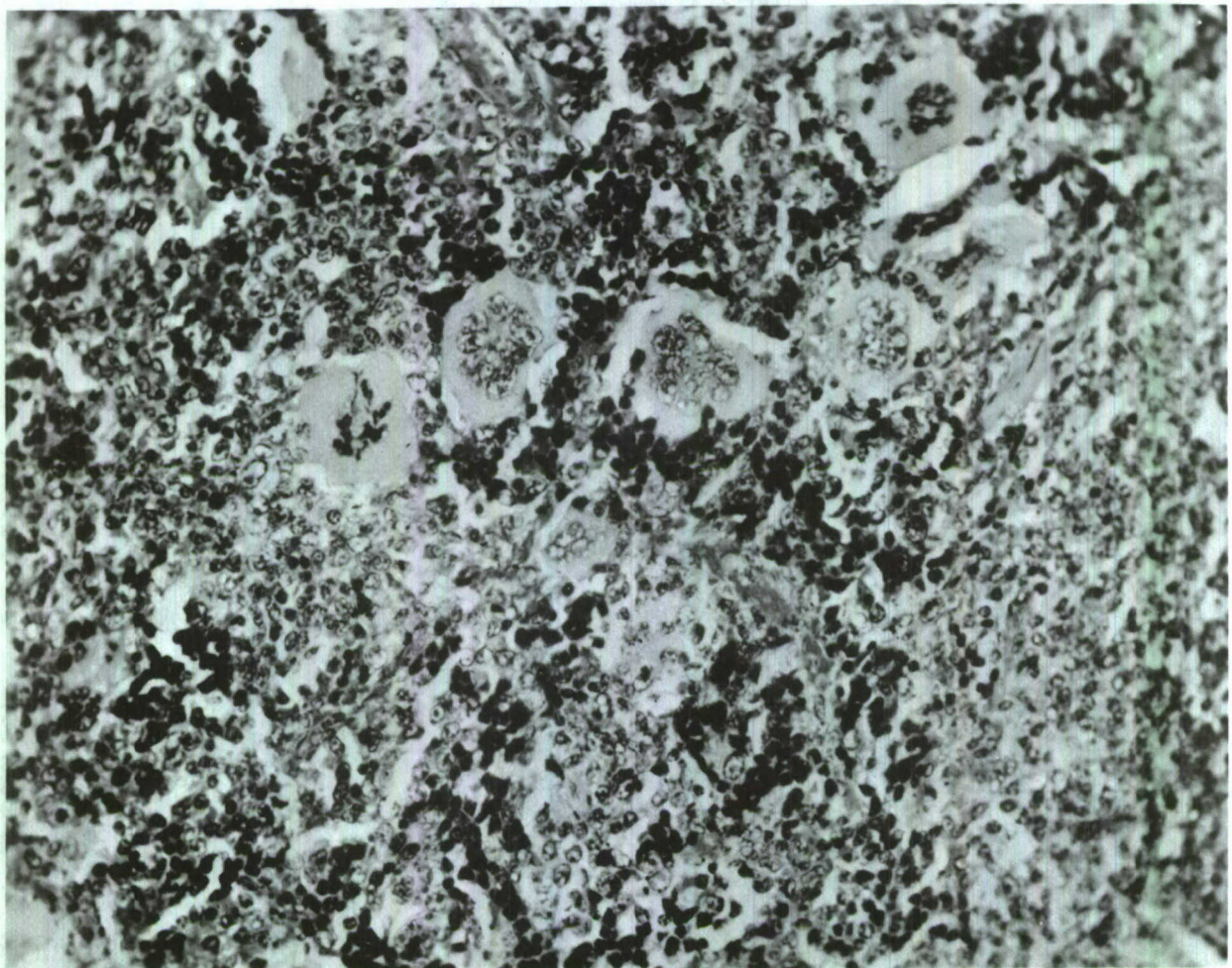

Figure 7.--Extensive extramedullary hematopoiesis in the spleen of an adult mink. Numerous megakaryocytes are demonstrated; the small dense cells are of the erythroid series. H & E. X275. AFIP Negative 70-11888.

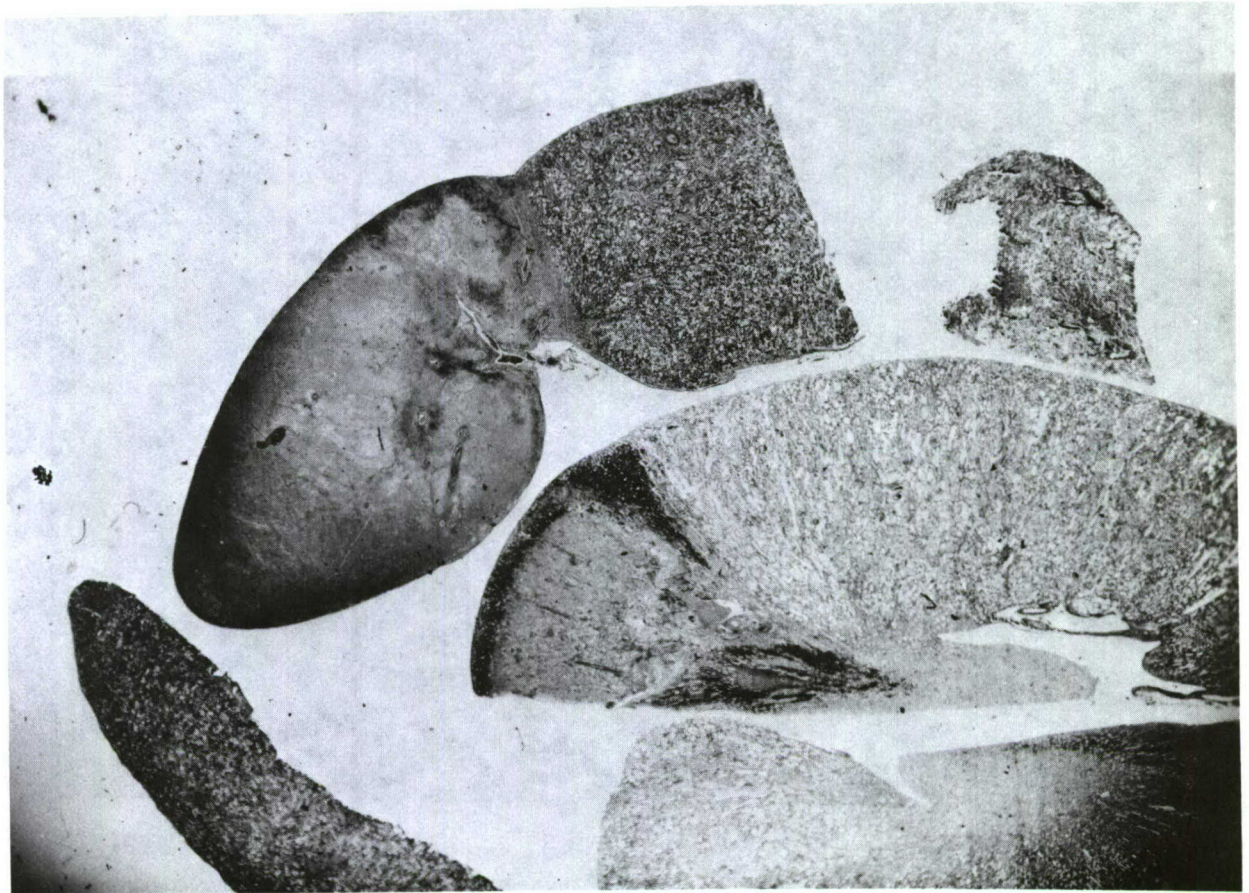

Figure 8.--Infarcts of tip of spleen and kidney of an adult mink.  
H & E. X5.5. AFIP Negative 70-11689.

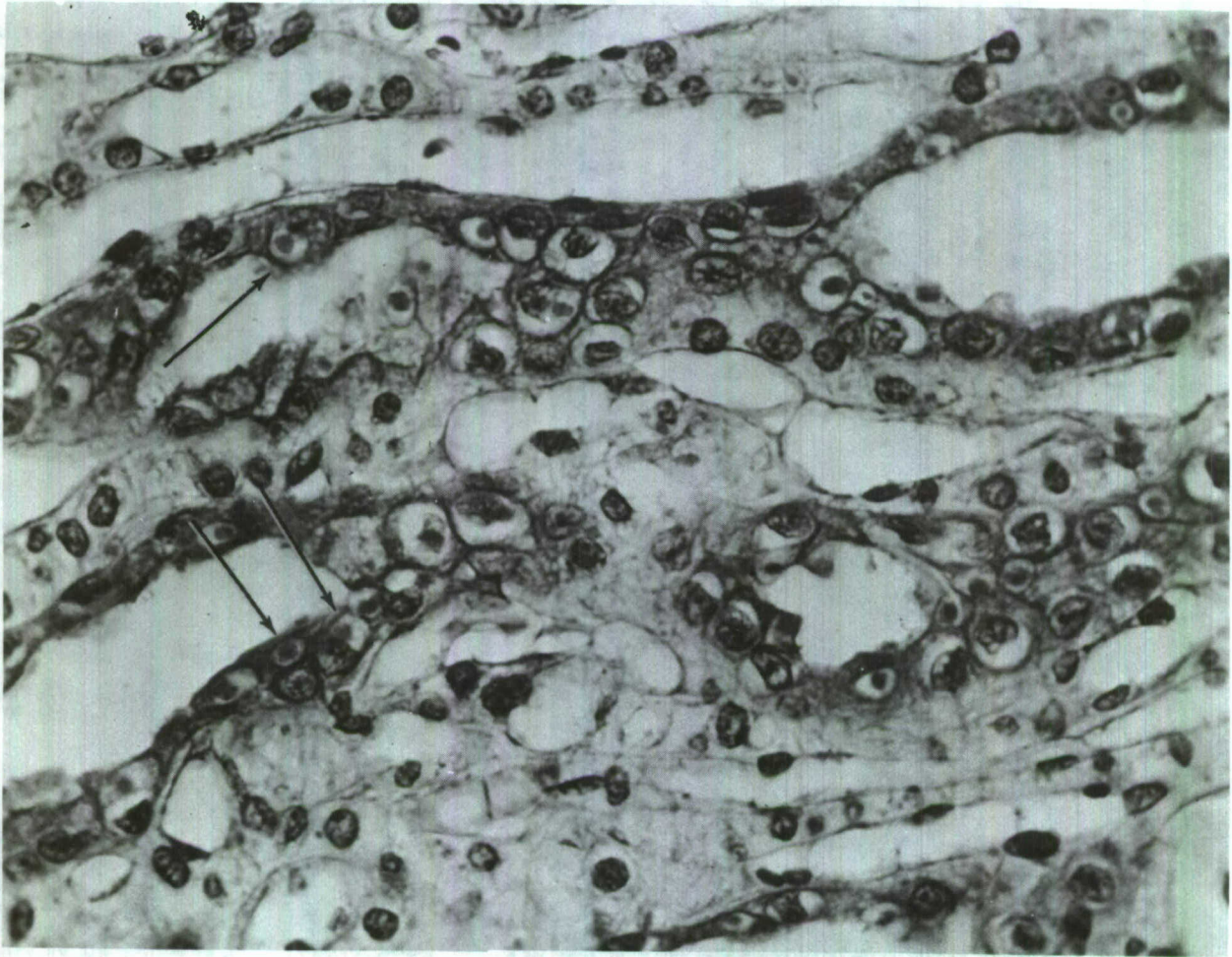

Figure 9.--Inclusions (see arrows) in the epithelium of the collecting tubules in the medulla of the kidney of an adult mink.  
H & E. X485. AFIP Negative 70-11962.



Figure 10.--Erosion of gastric mucosa of an adult mink,  
with granular exudate on surface.  
H & E. X45. AFIP Negative 70-11712.

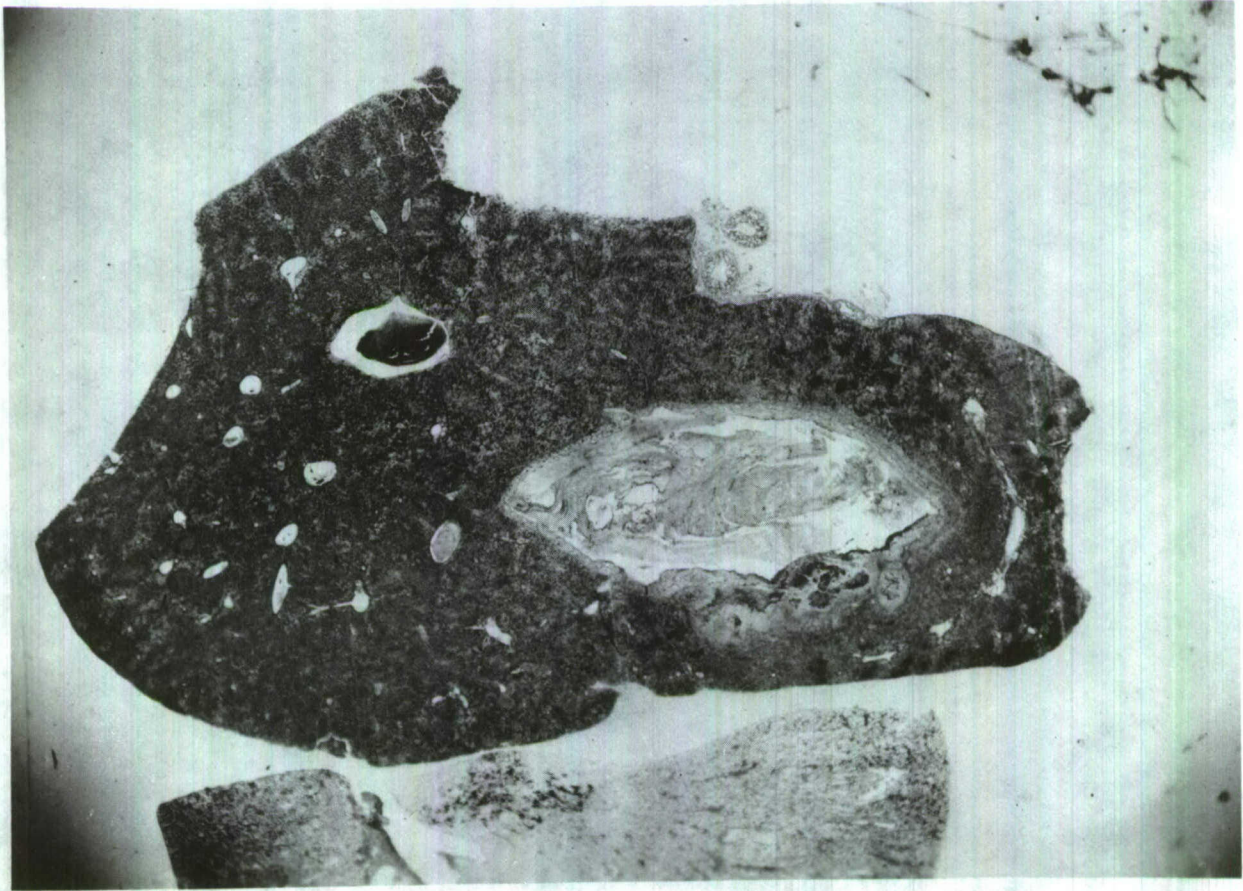

Figure 11.--Thrombosis and infarction of the intermediate lobe  
of the liver of an adult mink.  
H & E. X5.5. AFIP Negative 70-11693.

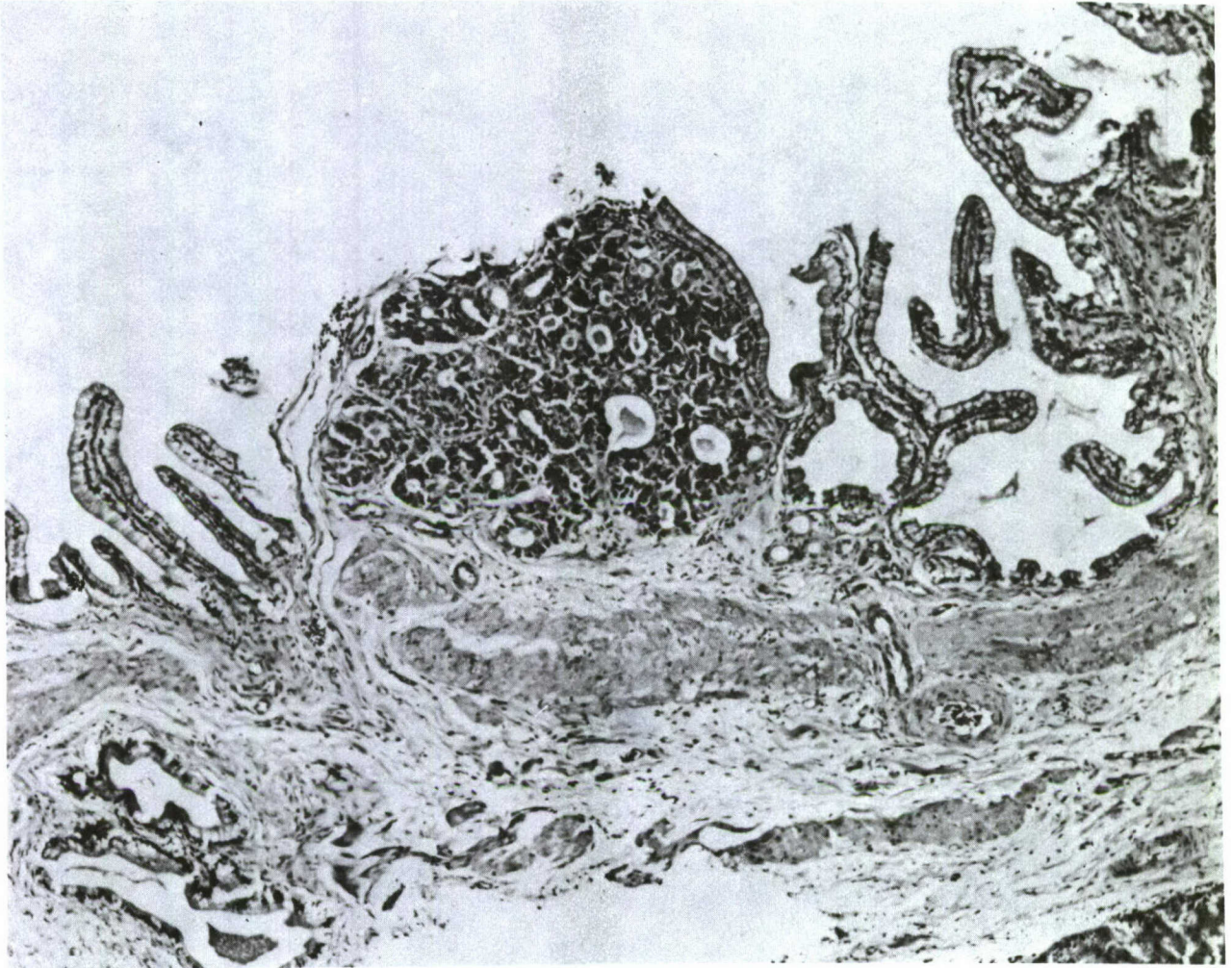

Figure 12.--Ectopic pancreatic acinar tissue in the mucosa  
of the gallbladder of an adult mink.  
H & E. X70. AFIP Negative 70-11970.

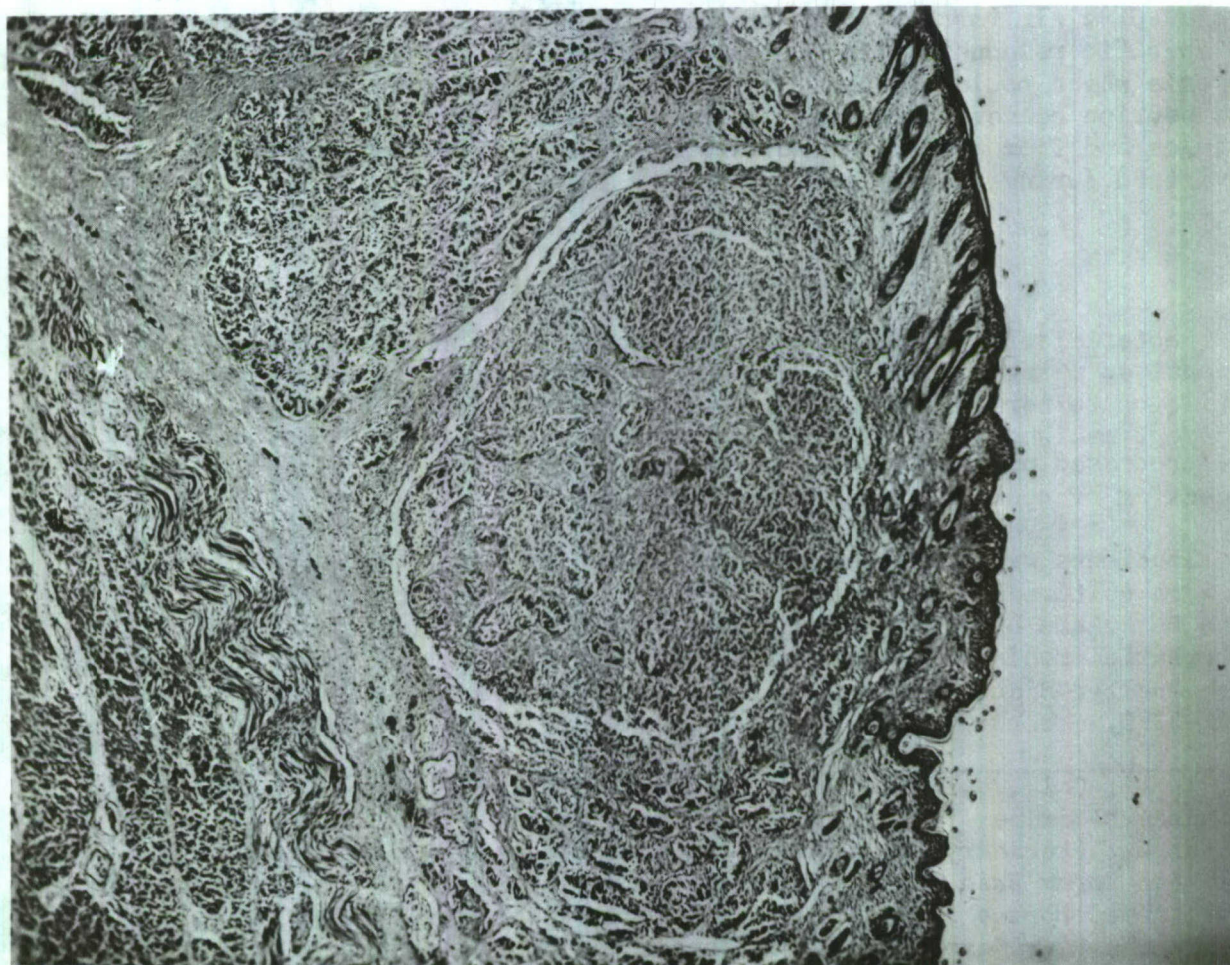

Figure 13.--Necropurulent inflammation of the adnexal glands of the dermis of the crest of the neck in a newborn kit.  
H & E. X45. AFIP Negative 70-11886.

Bacteriologic Findings in Adult and Newborn Mink  
Exposed to Real and Simulated Sonic Booms

Glenn A. Huttenhauer, Walter E. Brewer, and Farrel R. Robinson<sup>1,2/</sup>

INTRODUCTION

"Project Cool Mink" was a joint study by government and civilian organizations on the effects of sonic booms on whelping mink. It provides data applicable to alleged losses of fertility, increased abortion, and maternal cannibalism following exposure of mink to sonic booms. U.S. Air Force, School of Aerospace Medicine (SAM), personnel had specific responsibility for isolation and identification of bacteria which could adversely affect the health of test animals. This section concerns bacteria isolated from skin abscesses or pustules and from necropsy specimens of animals that died or were sacrificed during the tests.

MATERIALS AND METHODS

Bacteriologic specimens were collected at the sites and during necropsies, using aseptic techniques. Fluids were collected in dry sterile containers. Tissues and swabs were held in modified Amies transport medium (Difco).<sup>3/</sup> Specimens obtained at the Fur Station were processed promptly, but generally 2-5 hours elapsed before processing of specimens from the other sites.

Specimens were examined at the Fur Station, using gram stains, and were cultured on prepared Blood Agar, Mannitol Salt Agar, and Eosin Methylene Blue Agar or McConkey's Agar. A limited number of differential media were also used. Disk sensitivity tests were done using Mueller-Hinton Medium. Cultures were incubated aerobically at 35-37°C.

---

<sup>1/</sup> Lt. Col., U.S. Air Force, Biomedical Sciences Corps, School of Aerospace Medicine, Brooks Air Force Base, Texas 78235; Lt. Col., U.S. Air Force, Veterinary Corps, U.S.A.F. Environmental Health Laboratory, Kelly Air Force Base, Texas 78241; Lt. Col., U.S. Air Force, Veterinary Corps, Armed Forces Institute of Pathology, Washington, D.C. 20305.

<sup>2/</sup> The views expressed herein are those of the authors and do not necessarily reflect the views of the U.S. Air Force or the Department of Defense.

<sup>3/</sup> Trade names and company names are used in this publication solely to provide specific information. Mention of a trade name or company names does not constitute a guarantee or warranty of them by the U.S. Air Force or Department of Defense or an endorsement by the Department over those not mentioned.

Specimens intended for cultural identification and testing after return to Brooks Air Force Base were maintained at ambient temperatures. Upon return, specimens were inoculated to Tryptose Soy Agar (BBL), Blood Agar (Tryptose Blood Agar Base (Difco) with 5 percent sheep erythrocytes) and Chocolate Agar (Mueller-Hinton Base (BBL), "ISO Vitalex" Enrichment (BBL) and 2 percent Hemoglobin). Blood Agar plates were incubated aerobically at 37°C and 25°C and at 37°C under 10 percent CO<sub>2</sub>. Chocolate Agar plates were incubated at 37°C under 10 percent CO<sub>2</sub> and under anaerobic conditions. All plates were incubated for a minimum of 72 hours before being discarded. Colonies of each observed type were picked, streaked for isolation and purity, and used as stock cultures. Identification was made using appropriate differential media and serologic methods. Sensitivity tests were made using sensitivity disks (BBL) in the Kirby-Bauer technique on Mueller-Hinton Medium (BBL). Staphylococcus cultures were tested against the current phage series recommended by the National Communicable Disease Center (NCDC) for typing staphylococci from human sources as well as additional experimental phages used in typing staphylococci from animal sources.

## RESULTS AND DISCUSSION

Mink are subject to subepidermal and deeper tissue abscesses which occur primarily in the neck and head region. These have been collectively termed "boils." About a third of the experimental mink developed one or more abscesses after arrival in Alaska. In view of this, specimens for culture and antimicrobial testing were obtained from seven animals which developed abscesses.

Observations of smears from exudates were compatible with results of later cultures, although the fungus elements from Animal 199 and the staphylococci from Animal 472 were not seen. The organisms isolated from these abscesses are presented in Table 1.

The two isolates identified as Pasturella multocida were similar. Both had somewhat atypical biochemical reactions and probably represent a single virulent strain. A further discussion of these isolates as well as other P. multocida isolates found in this study follows the presentation of data concerning necropsy specimens.

The alpha-hemolytic Streptococcus was also atypical. The primary cultures appeared to contain a mixture of an alpha and beta-hemolytic streptococci, and diptheroids. The diptheroids were readily isolated; but despite numerous attempts to isolate two streptococci, all subcultures showed variable hemolysis. It was eventually shown that alpha hemolysis was produced around all colonies, but the apparent ability of this strain to produce varying amounts of hemolysis is disconcerting.

TABLE 1.--Bacterial Isolations from Abscesses

Site	Animal Number	Findings
Boom	142	Beta-hemolytic Streptococcus Group D
	260	<u>Staphylococcus epidermidis</u>
	276	No growth on culture
Control	199	Saprophytic fungus and Bacillus species
	215	<u>Pasturella multocida</u> and diptheroids
	472	<u>Pasturella multocida</u> , Bacillus species, and <u>Staphylococcus aureus</u> (non-typable)
	538	Alpha-hemolytic Streptococcus non-typable in Lancefield Groups A thru T, and diptheroids

The local Petersburg hospital had also made cultures from exudates before the arrival of the scientific team on 29 April 1970 and reported as significant bacteria Staphylococcus, Proteus and Escherichia coli.

No bacteria were isolated with the consistency to suggest a common causative agent for the abscesses. According to Gorham and Griffiths (5), abscesses may result when small bones or foreign matter in food or bedding penetrate through the mucosa to deeper tissues while the animal is chewing. These findings are compatible with that suggestion.

Many abscesses are probably self-limiting and undergo spontaneous resolution, but some become enlarged and impaired the animal. Abscesses on commercial mink ranches are usually treated by lancing through the dermis and expressing the exudate. Persistent abscesses in this herd were being treated with Penicillin. In view of the initial findings in this study, it was suggested that Ampicillin be substituted because of its broader spectrum of activity. Later, antimicrobial testing at Brooks AFB confirmed the effectiveness of this drug against P. multocida and Staphylococcus aureus. Penicillin was also effective against these organisms, but it would not be particularly useful against the Enterobacteriaceae or Enterococci previously identified. Treatment using Ampicillin apparently improved the situation and this gives further creditability considering abscesses as mixed unrelated bacterial infections.

Also of concern was a series of cases in kits which developed pustules about the head and neck as well as around the anus. Two such kits were returned to Brooks AFB for study. One of these was from the litter of Dam 472 at the control site which had an abscess producing S. aureus (non-typable) on culture. The other kit was from the litter of Dam 634 at the control site. Cultures of pustules from the head and neck and from the anal region of each kit were identified as S. aureus (not-typable). Antibiograms were performed on all isolates, and the results are shown in Table 2.

The apparent parallel in cultural findings and antibiograms between the dam and the kit suggests that the infection was transmitted to the kit from the dam. Similar situations may well have occurred throughout the herd, and it is possible that the "pustule" problem was caused by one or two strains transmitted by dams to their kits.

Specimens from the necropsy procedures showed a wide variety of organisms. See the pathology section for a comprehensive report by Robinson et al. of the pathology found in these animals and others necropsied in this test. Cases which involved bacteriologic study are given in Table 3.

TABLE 2.--Antibiotic Zone Sizes of Staphylococci Isolated from Pustules

Agents Tested	Conc	Zone Size Range (All Isolates)	Zone Size	
			Dam (R-472)	Kit
		(mm)	(mm)	(mm)
Prostaphlin	1 mcg	16-19	18	18
Penicillin	10 units	26-36	30	28
Erythromycin	15 mcg	12-20	16	17
Methicillin	5 mcg	0	0	0
Tetracycline	30 mcg	0	0	0
Ampicillin	10 mcg	34-36	34	34

TABLE 3.--Bacteriologic Findings in Necropsied Mink

Necropsies M-1-70 through M-62-70 were conducted prior to the test. Necropsies M-135-70 through M-191-70 were conducted on the day of the sonic boom. Necropsy M-230-70 was conducted on the day of the simulated boom. All others were conducted after the tests were completed.

<u>Necropsy No.</u>	<u>Sites</u>	<u>Findings</u>
M-1-70	Simulated	A female which died on 29 March and was frozen prior to the necropsy on 30 April. The gross diagnosis was pneumonia and pleuritis. Culture of the lung tissues showed the presence of <u>Pasturella multocida</u> .
M-2-70	Simulated	An adult which died from unknown causes was necropsied on 30 April. The gross diagnosis was necroptic rhinitis. The lung tissue yielded <u>S. aureus</u> .
M-5-70	Test	An unhealthy adult sacrificed and necropsied on 1 May. Multiple abscesses and purulent metritis were evident. Fluid from a sublumbar abscess showed <u>E. coli</u> and <u>P. mirabilis</u> . The intestinal contents also showed <u>P. mirabilis</u> and <u>E. coli</u> .
M-6-70	Simulated	An unhealthy adult sacrificed and necropsied on 1 May. Massive bilateral pleuritis was evident. Pleural fluid showed <u>P. mirabilis</u> .
M-7-70	Test	An unhealthy adult sacrificed and necropsied on 4 May. Bilateral pleuritis and pneumonia were evident. Culture of lung tissue produced <u>E. coli</u> . There was no growth in cultures of pleural fluid.
M-62-70	Test	A female found dead in her cage on 10 May with death thought to be related to whelping. A gross diagnosis of Dystocia was made. <u>S. aureus</u> (non-typable) was isolated from the uterus. The antibiogram for this organism closely resembles those for the Staphylococcus from the Dam 472 and her kits, and since this animal was also at the test site this may be the same strain as that causing "pustules."

<u>Necropsy No.</u>	<u>Sites</u>	<u>Findings</u>
M-135-70	Test	This female had whelped and lost a part of her litter. She was sacrificed on 11 May after the test primarily as a control animal and had no outstanding gross lesions. <u>S. epidermidis</u> and a Pseudomonas species (unclassified) were isolated from the uterus.
M-190-70	Control	This female had also whelped and lost her litter. She was sacrificed after the test on 11 May. A retained placenta was found. Culture of the urine showed <u>P. mirabilis</u> . Cultures of the uterus also produced <u>P. mirabilis</u> and a Beta-hemolytic Streptococcus (Group G) as well.
M-191-70	Control	A control animal sacrificed following the test on 11 May with no apparent gross lesions. A growth of <u>S. epidermidis</u> was found in culture of the uterus.
M-230-70	Control	This animal was sacrificed on 12 May as a control and had no apparent gross lesions. No bacterial growth was found on culture.
M-233-70	Test	This female was sacrificed on 13 May after losing her litter. Gross findings included peritonitis, vaginitis, ruptured uterus and considerable heteroplastic bone in the lungs. An atypical Streptococcus (Lancefield Groups A through T negative) was found in the uterine tissue. Beta-hemolytic Streptococcus (Group G) was found in blood culture and <u>P. mirabilis</u> was found in lung tissue.
M-234-70	Test	This female was sacrificed on 13 May after problems with her litter. There were no gross lesions. Culture of the uterus produced <u>P. multocida</u> and Pseudomonas species (unclassified).
M-236-70K & M-237-70K		Suckling kits which were taken in their entirety for bacteriologic specimens. The only organisms recovered from these kits were <u>P. mirabilis</u> from cultures of the skin.

There is an apparent relationship in most of the cases referred to in Table 3 to the pathology findings. The variety of organisms and their apparent random occurrence over the time span of the tests does not indicate any specific common health problem in the herd, either before or after the sonic booms were delivered.

The recovery of P. multocida from the lung in case M-1-70, the uterus in case M-234-70, and the abscesses of Animals 215 and 472 are of interest. All of these isolates had the same rather atypical characteristics. While most reactions agreed with the description of the organisms given in Bergey's Manual (2), there were five atypical fermentations and unusual growth characteristics on agar plates which suggest a strain peculiar to mink differing from those reported by Smith (6) for other animals. The concept of a normally occurring organism becoming virulent when the host is debilitated might be applied here to account for the diverse pathogenesis. The characteristics of these isolates are as follows:

Initial isolations were made from blood agar. Colonies were nonhemolytic, about 1 mm in diameter, translucent white and slightly convex. Somewhat larger colonies were produced on plates incubated under CO<sub>2</sub> than on those incubated under aerobic conditions. On later subcultures slight alpha hemolysis was produced. There was no initial growth on McConkey's agar, but, again, slight growth was produced after subculturing.

The organisms were gram negative and appeared as small coccoid rods. Motility tests were negative. Catalase, oxidase, nitrate, and indole tests were positive. Production of hydrogen sulfide was detected using lead acetate paper but not by other means. The methyl red test was negative while the Voges-Proskauer test was positive. Acid but not gas was produced from glucose, sucrose, and xylose as well as from maltose. No acid was detected from lactose, salicin, and adonitol or from mannitol. Decarboxylase tests in lysine and arginine were negative, but a positive reaction was observed with ornithine.

The Special Bacteriology Laboratory of NCDC in Atlanta, Ga., confirmed the reactions from subcultures of one isolate and tested additional substrates for fermentations. In addition to maltose and mannitol being at variance with the usual patterns of P. multocida, ducitol and dextrin were fermented while sorbitol was not. These reactions, the late hemolysis of blood agar and growth on McConkey's casts some doubt on the positive identification of the organisms as P. multocida (1, 2, 3, 4) and NCDC therefore reported the organism only as "Possible Pasturella multocida."

## CONCLUSIONS

There was no evidence that bacterial disease was induced in the herd by exposure of the animals to sonic booms.

Results of these studies are compatible with the concept that abscesses are caused by bone fragments or foreign matter in food or bedding penetrating through the mucosa to deeper tissues while the mink are chewing. The broader spectrum antibiotic Ampicillin offers advantages for treatment of these abscesses because of the multiplicity of organisms which can be expected.

There is evidence for transmission of Staphylococcal disease within the herd between a dam and her kits. There was no evidence of other serious contagious diseases, although isolated instances of infectious diseases were revealed by necropsy findings.

The isolations of P. multocida, producing characteristic but atypical reactions, may indicate a species or local specific variant of the organism capable of virulence when the animals are debilitated.

There is no evidence of variation in the bacteria found at the three sites.

## LITERATURE CITED

1. Bailey, W. R., and Scott, E. G.  
1970. Diagnostic Microbiology. 3rd ed. C. V. Mosby Co.,  
Saint Louis, Mo.
2. Breed, R. S., Murray, E. G. D. and Smith, N. R.  
1957. Bergey's Manual of Determinative Bacteriology. 7th ed.  
Williams and Wilkins Co., Baltimore, Md.
3. Carter, G. R., and Bain, R. V. S.  
1960. Pasteureliosis (Pasteurella multocida). A review  
stressing recent developments. Vet. Rev. Annot. 6:  
105-128.
4. Dubos, R. J., and Hirsch, J. G.  
1965. Bacterial and Mycotic Infections of Man. 4th ed.  
J. B. Lippincott Co., Philadelphia, Pa.
5. Gorham, J. R., and Griffiths, H. J.  
1952. Diseases and Parasites of Minks. USDA Bulletin No.  
2050. U. S. Government Printing Office, Washington,  
D. C.
6. Smith, V. E.  
1958. Studies on Pasteurella septica. II. Some cultural  
and biochemical properties of strains from different  
host species. J. Comp. Path. 68: 315-323.

# Virology of Mink (Females and Kits) Exposed to Real and Simulated Sonic Booms (Project Cool Mink)

James B. Henson, DVM, Ph.D.<sup>1/</sup>

## INTRODUCTION

It has been recognized for a number of years that viruses can cause intrauterine death, abortion, and early mortality of mink kits. Aleutian disease (AD) virus is most important in this regard. We have previously demonstrated that Aleutian disease virus is transplacentally transmitted<sup>2/</sup>. Decreased kit production and early death of kits ensue. This mechanism, along with early intimate contact between infected females and their kits, is the primary means of AD transmission. Other viruses can cause abortion and early kit mortality, but these agents are less important than AD virus.

With this in mind, studies were carried out to investigate the presence of the viruses of AD, mink virus enteritis, canine distemper, and mink encephalopathy in females and kits in the Alaska Sonic Boom Mink Study.

The findings were related to the occurrence of adult and kit mortality and to the influence of sonic booms (intensity of approximately 6 pounds per square foot) on mink. The studies were divided into two general aspects. One was an evaluation of the females and kits at the site near Petersburg, Alaska. The clinical appearance of the animals, necropsy of dead females and kits and serum collection from the females were carried out at that time. The second part of the investigations was evaluation of the serum and fetal tissues in the Virology Laboratory, Washington State University, at Pullman, Washington.

## MATERIALS AND METHODS

### Females

Clinical Evaluation: Each of the females at the test, simulator, and control sites was caught and examined individually the first week in July 1970. The general physical condition of each female was noted and any indication of previous disease recorded.

Gross and Microscopic Lesions: Four dead females were available for necropsy and examination during our visit to the site. A complete autopsy was performed and various organs collected in 10 percent formalin for transport back to Washington State University for microscopic examination.

---

<sup>1/</sup> Professor and Chairman, Department of Veterinary Pathology, Washington State University, Pullman, Washington 99163.

<sup>2/</sup> Padgett, George A., Gorham, John A., and Henson, James B. 1967. Epizootiologic Studies of Aleutian Disease--Transplacental Transmission of the Virus. J. of Infectious Diseases. 117:35-38.

Serum Gamma Globulin Levels: Serum gamma globulin levels are indicative of the presence of Aleutian disease in a mink herd, since the disease is characterized by hypergammaglobulinemia. The gamma globulin elevation occurs early in the course of the disease and persists throughout the life of most infected animals. This is especially true of mink that are homozygous recessive for the Aleutian gene.

Each female alive at the time of the site visit was caught and two serum samples collected as previously described. The serum samples from each female were individually identified, frozen, and transported frozen to our laboratory in Pullman for electrophoretic separation and determination of the serum gamma globulin levels.

### Kits

Clinical Evaluation: The kits in all of the test groups were observed during the site visit. The general condition of the kits as well as the occurrence of any lesions were noted.

Gross and Microscopic Lesions: A total of 11 kits was autopsied at the site. The gross lesions were recorded, and tissues from six of these dead kits were fixed in 10 percent neutral formalin and transported to the laboratory for microscopic examination. The lungs of four of the dead kits were frozen and transported to Pullman for bacteriological examination.

Viral Transmission Studies: A total of 102 dead kits was sent to us frozen in dry ice. Each of these kits was examined, and those that appeared to be too autolyzed for evaluation were discarded. Thirty-six kits from females at the control site, 47 kits from females from the test site, and 11 kits from females from the simulator site were received. The origin of five kits could not be determined.

After cleaning the kits as well as possible, the ventral body wall was incised, using sterile instruments, and the thoracic and abdominal viscera removed as previously described. Previous work at Washington State University has indicated that this procedure is an effective method for demonstrating Aleutian disease virus. The viscera from four to six kits within the same treatment group was pooled, weighed, and 10 percent tissue suspension made in phosphate buffered saline (PBS) containing penicillin and streptomycin. Each of two mink was injected with 1 ml of each tissue suspension subcutaneously. Prior to inoculation, serum samples were taken from the test mink for gamma globulin determination. The injected mink were examined daily for the occurrence of clinical disease and were maintained under standard mink husbandry practices. Any injected mink that died were necropsied and tissues collected for histopathology. One of the two mink injected with each of the pools was killed 56 days and one 76 days after inoculation. Blood was collected by cardiac puncture from each mink after pentobarbital anesthesia. Serum was collected and

separated electrophoretically. Complete necropsies were performed and tissue collected for histopathologic evaluation. Particular attention was paid to the occurrence of lesions indicative of Aleutian disease and mink virus enteritis.

One ml of each of the tissue pools was also injected subcutaneously into distemper susceptible ferrets. Since distemper virus produces a very predictable disease course in ferrets, the animals were observed twice daily for the occurrence of clinical signs and death attributable to this disease. The signs expected in distemper infected ferrets included squinting of the eye, serous then seropurulent ocular and nasal exudate discharge, swelling and crusting of the foot pads, and death. This portion of the trial was terminated 1 month after inoculation of the test material.

## RESULTS

### Females

Clinical Evaluation: Examination of all the females indicated that they were generally in poor condition. Many of the females also had residual or active pyoderma and abscesses. A number were noted to be very thin, and a few were anemic. No difference was noted between animals that had been located at the various sites.

Gross and Microscopic Lesions: Examination of the four adult animals that died while Dr. Henson and associates were in Alaska indicated that two of these had pyogenic infections. One female (R546) had a severe chronic, necrotizing mastitis due to pyogenic cocci. Female RA292 had a chronic, fibrinopurulent pleuritis. Females R94 and R666 were extremely thin and had very fatty livers. The occurrence of gradual weight loss with a fatty liver is characteristic of nursing sickness in mink and is commonly found in a few animals in most mink herds.

Serum Gamma Globulin Levels: The serum gamma globulin levels are given in Appendix I. Values are given for all the females alive the first week of July 1970. Serum samples from 394 females were separated electrophoretically on cellulose acetate and the gamma globulin levels expressed as a percentage of the total serum protein. A total of 303 females had gamma globulin levels less than 20 percent of the total serum proteins. Eighty-two had gamma globulin levels between 20 and 30 percent, and nine had values above 30 percent. One of the latter nine animals had a value of 48 percent. Values below 20 percent are considered normal. The occurrence of gamma globulin levels above 20 percent was distributed randomly among the two age groups--females (2-year-olds and yearlings) and among the females located at the different sites.

## Kits

Clinical Evaluation: Based on Dr. Henson's past experience and his examination of the kits during the site visit, the kits did not appear to be as large and vigorous as one would expect on an average commercial mink ranch. This seemed to be true of practically all the kits, with no difference noticed at the different sites. A number of kits had chewed ears, pyoderma, and abscesses. Instances of kits nursing or chewing on each other's ears were noted. It was recommended that more fat be included in the diet, since the usual cause for the above condition among kits is attributable to low-fat diets in the females.

Gross and Microscopic Lesions: Autopsy of 11 kits that died during our visit to the project indicated that most were dying from an acute, bacterial pneumonia. The lungs of 10 of these kits were extremely red and firm. Other tissues were normal. In addition, several live kits were noted to have a serosanguineous nasal discharge. The lesions and the clinical appearance of the kits suggested the occurrence of hemorrhagic pneumonia. Pseudomonas aeruginosa was isolated from the lungs of four kits. It was recommended that treatment by sulfathiazole be initiated to combat this infection. One of the kits necropsied had a chronic, purulent peritonitis.

The results of clinical evaluation, autopsies, histologic evaluation, and bacteriological cultures indicated that several factors were influencing the kits. They appeared somewhat malnourished, probably due to the widespread pyogenic infections in the females. Kits were dying from pyogenic infections and hemorrhagic pneumonia. Many had or were currently suffering from skin infections.

Virus Transmission Study: Three of the test mink inoculated with organ suspensions from dead kits died during the course of observations. All three had chronic purulent pleuritis. A streptococcus was isolated in pure culture from the pleural exudate from two of these animals, and a pure culture of salmonella was isolated from the other.

Three of the inoculated mink developed serum gamma globulin levels greater than 20 percent of the total serum proteins. Two of these animals had levels of 21 percent, and one had 23 percent. In all instances the preinoculation levels were within the normal range.

When the tissues from the inoculated mink were examined grossly, no lesions were evident. Microscopic examination revealed few changes. Four animals had small collections of lymphocytes located periportally in the liver. Similar collections are often found in the general mink population and are not considered significant. One animal had a few interstitial collections of lymphocytes in the kidney. No other microscopic lesions were observed in any of these animals.

No lesions definitely attributable to Aleutian disease or mink virus enteritis were demonstrated in any of the inoculated animals. The ferrets inoculated with the tissue suspensions from the dead kits remained healthy. They did not show any signs of distemper, and none died during the observation period.

#### CONCLUSIONS

The females, in general, did not appear as healthy as expected. This was apparently due to the occurrence of widespread infection by pyogenic bacteria. Both streptococci and salmonella were transmitted from infected, dead kits to test mink. The conditions in the females did not appear to be related in any way to sonic boom exposure. There were no detectable differences in the overall health of the females at the three sites (control, simulated sonic boom and real sonic boom).

The kits in general were not as healthy and robust as they should have been. Many had evidence of pyogenic infection and ear chewing. Ten of the kits autopsied had hemorrhagic pneumonia of bacterial origin.

No evidence for the occurrence of any virus known to cause disease in mink was demonstrated.

Aleutian disease virus was not demonstrated. This is shown by the following: The pattern of a hypergammaglobulinemia in the females was not that expected in a herd with Aleutian disease. Ninety-one females had serum gamma globulin levels above 20 percent, but most of these were in the range of 20 to 30 percent of the total serum proteins. Only nine had gamma globulin levels above 30 percent, and one of these was above 40 percent. One expects to see a larger number and much higher gamma globulin levels in a herd of mink experiencing Aleutian disease. In the opinion of Dr. Henson, the occurrence of hypergammaglobulinemia resulted from chronic pyogenic infections. No lesions of Aleutian disease were observed in either the animals necropsied at Washington State University or those necropsied by Lt. Col. Robinson at the Armed Forces Institute of Pathology (Pathology section). The test mink injected with the material from dead kits did not develop hypergammaglobulinemia or characteristic lesions of Aleutian disease.

No evidence of mink virus enteritis was shown. The clinical appearance of the females observed by personnel from Washington State University during their visit to the three test sites and the history on the ranch was not consistent with the occurrence of mink virus enteritis. The lesions in the dead females were not those seen in mink virus enteritis. Mink virus enteritis was not transmitted to susceptible mink by the injection of tissue suspensions from dead kits.

Canine distemper virus was not shown to be present. No lesions or clinical histories characteristic of canine distemper were observed. Transmission of distemper by tissue suspensions of dead kits to susceptible ferrets was not accomplished. No evidence of mink encephalopathy was shown. The herd history was not characteristic for this disease. The lesions observed in necropsied females by Dr. Henson and Lt. Col. Robinson were not those of mink encephalopathy.

No other common viruses could be demonstrated by injection of test material.

Viruses did not appear to play a role in the occurrence of disease or mortality of either females or kits in the 1970 Alaskan sonic boom mink study.

APPENDIX I. SERUM GAMMA GLOBULIN IN LEVELS IN THE ADULT MINK  
ON THE SONIC BOOM STUDY

"C" = CONTROL

<u>Mink No.</u>	<u>Pct. Gamma</u>	<u>Mink No.</u>	<u>Pct. Gamma</u>
R-522	12.4	R-476	21.1
R-662	14.9	R-696	17.6
R-660	10.0	RA-270	29.4
RA-320	13.7	RA-232	21.0
R-658	10.3	RA-312	19.3
R-562	16.2	R-622	16.3
RA-222	18.7	RA-204	20.8
R-502	16.6	RA-266	23.8
RA-306	17.6	R-538	12.5
R-588	17.5	R-494	13.1
RA-290	14.5	R-498	17.6
R-510	10.7	R-638	18.6
R-532	13.3	R-530	17.1
R-618	6.8	R-548	10.2
R-584	16.8	R-588	15.0
R-706	16.9	R-690	19.5
R-692	7.8	R-518	10.3
R-616	16.4	R-564	16.0
R-724	11.0	R-728	9.0
R-738	15.0	R-460	14.3
RA-268	23.3	R-568	15.4
RA-284	19.1	RA-242	20.0
R-652	17.4	R-632	18.7
R-488	10.6	RA-286	12.8
R-494	18.4	R-624	13.3
R-598	24.0	R-656	12.3
RA-230	18.6	R-646	13.6
R-704	17.8	R-566	13.0
R-534	15.0	RA-316	19.5
R-704	15.0	R-718	12.4
R-490	25.1	R-650	15.7
R-592	12.7	R-500	16.5
RA-210	13.8	R-654	28.0
RA-258	2.7	R-734	9.2
R-576	17.8	R-700	23.2
R-480	20.0	R-514	10.4
RA-318	20.6	R-714	14.6
R-578	23.9	R-458	21.2
RA-236	23.9	RA-260	14.3
R-740	21.1	R-526	14.1

Cont'd

"C" = CONTROL

---

<u>Mink No.</u>	<u>Pct. Gamma</u>	<u>Mink No.</u>	<u>Pct. Gamma</u>
R-482	20.7	R-682	18.8
RA-310	30.4	RA-238	28.2
RA-308	22.6	R-702	18.9
R-692	19.1	R-506	5.9
R-528	23.1	RA-276	7.7
RA-250	21.3	R-682	16.0
RA-226	20.0	R-694	14.3
R-626	18.9	R-512	13.4
RA-300	22.1	R-732	12.3
R-628	21.2	RA-278	17.0
R-594	19.2	R-560	19.5
R-540	14.2	R-642	18.0
RA-298	7.7	R-550	13.9
R-470	7.9	R-484	13.6
R-676	15.8	RA-254	30.7
R-726	11.8	R-620	12.0
R-528	11.0	R-570	8.2
R-472	16.6	RA-234	24.4

Cont'd

"B" = BOOM

---

<u>Mink No.</u>	<u>Pct. Gamma</u>	<u>Mink No.</u>	<u>Pct. Gamma</u>
R-210	16.1	RA- 84	31.1
R- 238	17.0	R-222	36.5
RA- 54	15.0	R-152	22.5
R-262	16.7	RA- 98	17.5
R-270	15.3	R-158	29.1
R-168	17.5	R-114	26.1
R- 88	9.0	R- 36	20.2
R- 60	12.1	R-162	24.9
R-268	13.9	RA- 22	18.1
R-218	12.1	RA- 76	17.7
RA- 24	14.5	R- 2	17.5
RA- 10	14.0	RA- 22	28.3
R-172	17.1	R- 40	24.1
R- 62	16.1	RA-118	32.3
R-246	6.8	R-128	23.2
R-204	22.9	R- 54	20.0
RA-100	13.2	R-240	21.3
R-186	14.8	R-244	9.8
R- 58	14.4	RA- 18	22.4
RA- 52	15.1	R-132	18.7
RA- 70	13.0	R- 28	16.8
R-254	16.8	RA- 88	21.2
R-136	18.6	R- 58	18.6
R-140	16.8	R-214	23.4
R- 76	21.0	RA- 48	20.2
RA- 8	21.1	R-228	13.8
RA- 80	20.1	R-120	12.2
RA- 78	13.8	RA- 6	14.2
R- 38	9.7	RA-116	22.1
R- 16	17.2	RA- 36	18.6
RA- 26	22.2	RA-104	22.3
R-248	7.8	R-230	15.7
R-256	10.3	R- 82	4.9
R-220	10.6	RA- 32	22.3
R-158	9.3	R- 66	16.0
R-188	16.8	RA- 74	19.7
RA- 30	18.7	RA-108	13.2
R-106	21.2	R-176	13.0
R-196	19.6	R-200	4.5
R-252	25.4	R-206	10.2

Cont'd

"B" = BOOM

<u>Mink No.</u>	<u>Pct. Gamma</u>	<u>Mink No.</u>	<u>Pct. Gamma</u>
R- 10	23.4	R- 50	23.2
RA- 70	16.8	R-282	17.3
R-284	26.2	R-184	19.7
R-264	5.9	RA-106	25.3
RA- 68	12.4	RA- 58	12.8
R- 20	9.2	R- 80	14.2
R-274	10.6	RA- 82	17.6
RA-120	32.3	R- 84	23.4
RA- 82	20.3	RA- 94	19.6
RA- 72	15.5	RA- 28	23.2
R-108	5.4	R-214	12.8
R- 72	8.6	RA- 50	10.3
R-154	12.2	R- 96	23.2
R-202	29.2	R- 64	10.5
R-260	17.6	RA- 60	11.5
R-182	15.4	R-206	17.0
RA- 10	13.0	R-140	24.5
R-276	17.0	R- 60	18.8
R- 64	18.9	R- 42	16.1
R-102	7.9	RA- 62	11.2
RA- 40	31.0	R-112	22.5
R-236	22.2	R-224	13.8
R-192	25.7	RA- 44	25.5
R-442	11.3	R-348	21.0
R-448	13.5	R-352	16.7
R-310	14.4	R-304	22.7
R-452	15.8	RA-198	11.0
R-316	14.9	R-418	17.4
R-404	12.8	R-306	13.2
R-416	11.5	RA-124	14.2
RA-162	12.2	R-302	14.6
R-342	17.1	RA-142	25.6
R-308	14.2	RA-144	10.7
R-446	19.5	R-430	17.6
R-300	14.4	R-296	25.5
R-356	17.7	R-390	14.3
R-394	19.0	RA-170	16.1
R-382	15.4	R-358	11.0
R-436	14.2	R-412	18.8
RA-194	16.0	RA-164	20.5
R-280	9.3		

Cont'd

"B" = BOOM

---

<u>Mink No.</u>	<u>Pct. Gamma</u>	<u>Mink No.</u>	<u>Pct. Gamma</u>
R-334	24.0	RA-196	28.0
R-438	18.9	R-328	20.7
RA-174	12.2	RA-138	12.2
RA-150	17.1	RA-168	20.9
R-408	17.3	RA-184	25.8
R-368	15.3	R-402	19.3
R-292	16.6	RA-134	12.2
R-386	17.6	R-322	11.7
R-414	8.9	R-314	17.2
R-424	13.5	RA-190	19.3
R-428	20.7	RA-148	21.3
R-398	13.4	RA-186	24.4
R-354	27.4	R-432	6.8
R-378	11.0	R-370	21.9
R-420	15.7	R-372	10.0
R-400	10.9	R-388	9.2
RA-176	48.9	RA-132	13.3
R-384	16.5	R-396	16.4
R-330	22.8	RA-146	26.1
R-312	26.5	RA-152	18.5
R-444	22.6	R-288	18.0

Cont'd

"S" = SIMULATOR

---

<u>Mink No.</u>	<u>Pct. Gamma</u>	<u>Mink No.</u>	<u>Pct. Gamma</u>
R-442	11.3	R-348	21.0
R-448	13.5	R-352	16.7
R-310	14.4	R-304	22.7
R-452	15.8	RA-198	11.0
R-316	14.9	R-418	17.4
R-404	12.8	R-306	13.2
R-416	11.5	RA-124	14.2
RA-162	12.2	R-302	14.6
R-342	17.1	RA-142	25.6
R-308	14.2	RA-144	10.7
R-446	19.5	R-430	17.6
R-300	14.4	R-296	25.5
R-356	17.7	R-390	14.3
R-394	19.0	RA-170	16.1
R-382	15.4	R-358	11.0
R-436	14.2	R-412	18.8
RA-194	16.0	RA-164	20.5
R-334	24.0	RA-196	28.0
R-438	18.9	R-328	20.7
RA-174	12.2	RA-138	12.2
RA-150	17.1	RA-168	20.9
R-408	17.3	RA-184	25.8
R-368	15.3	R-402	19.3
R-292	16.6	RA-134	12.2
R-386	17.6	R-322	11.7
R-414	8.9	R-314	17.2
R-424	13.5	RA-190	19.3
R-428	20.7	RA-148	21.3
R-398	13.4	RA-186	24.4
R-354	27.4	R-432	6.8
R-378	11.0	R-370	21.9
R-420	15.7	R-372	10.0
R-400	10.9	R-388	9.2
RA-176	48.9	RA-132	13.3
R-384	16.5	R-396	16.4
R-330	22.8	RA-146	26.1
R-312	26.5	RA-152	18.5
R-444	22.6	R-288	18.0

144 sq. ft. = 15, 14

## SUMMARY AND CONCLUSIONS

James Bond<sup>1/</sup>

Scientists representing the U.S. Department of Agriculture, the U.S. Air Force, the University of Alaska and Washington State University conducted an interdisciplinary study on Mitkof Island, Alaska, to determine the effects of real and simulated sonic booms upon late pregnancy, parturition, early kit mortality and subsequent growth of 498 farm-raised mink (Mustela vison) mothers and their 1,845 progeny. The study was observed by representatives of the Federal Aviation Administration, the National Academy of Sciences, the U.S. Department of Interior, and the Mink Farmers Research Foundation. Test animals of the violet color phase (pp alal bmbm) were purchased in Oregon and air-transported in January 1970 to Petersburg where they were randomly divided into three groups: 200 females and 50 males subjected to real sonic booms; the same number as unboomed controls; and 120 females and 30 males subjected to simulated booms. They were fed and handled alike by the same caretakers and were bred between March 13 and April 5.

On May 11, when 40 percent of the females had whelped, mink at the "boom" site were subjected to three sonic booms (1058, 1144, 1200) produced by a U.S. Air Force supersonic aircraft on a course designed to generate booms of 6 pounds per square foot overpressure.

On May 12, mink at the simulator site were subjected to three simulated booms. The simulator was a large horn into which two charges of compressed gas could be released suddenly and by rupture of thin diaphragms to propagate pressure pulses from the horn. Mink nearest the simulator were subjected to overpressures of 5.8 pounds per square foot.

The mink were housed in similar conditions at three test sites. Individual wire cages were 4.5 feet above ground under peaked shed roofs. Wood nest boxes were attached, and almost all of the mink were in these during tests. The booms averaged 5.66 pounds per square foot peak overpressure and directly caused transient structural vibrations of the shed roof with accelerations over 2 g. (acceleration of gravity) but accelerations of the nest boxes did not exceed 1 g. The main motion of the nest boxes was a vibration at 10 Hertz with maximum total movement of about 0.24 inch. Seismic effects of the booms on the sheds were negligible. Simulated booms averaged 3.5 pounds per square foot peak overpressure in the sheds, and caused acceleration of the roof up to 1.2 g., and of the nest boxes, 0.5 g. Maximum total movement of nest boxes was about 0.0024 inch. The control site received no booms, and all three sites received similar noises such as road traffic.

---

<sup>1/</sup> Project Leader and Research Animal Scientist, Animal Science Research Division, ARS, Beltsville, Maryland 20705.

Forty female mink were selected as a sample of the colony exposed to real sonic booms for visual observation. Ten observers were positioned behind a blind constructed around the mink sheds and recorded the behavior of the sample females on three baseline observation days and sonic boom exposure day. Observation periods were 3 hours in duration and included the projected times of the three sonic booms. All observations and the time at which they occurred were recorded by the observers on magnetic tape and later transferred to data sheets for analysis. On the day of sonic boom exposure, a closed-circuit TV system recorded the activity of one female and her kits.

Twenty female mink housed at the simulator location were observed on 1 baseline observation day and exposed 48 hours later to three simulated sonic booms. The procedures used to observe and record the activity of female mink exposed to real sonic booms were also used by five observers to monitor the activity of the females exposed to simulated booms. The behavior of one female with kits was also recorded on video tape on the day of exposure to simulated booms.

The mean length of gestation or the mean data of last mating was not significantly different among experimental treatments. Because of the design of the experiment, those mink that whelped post-boom or post-simulation were bred later and had longer gestation periods than those mink that whelped pre-boom or pre-simulation. This was to be expected.

The mean whelping date was approximately 1 day later ( $P < 0.01$ ) for mink in the simulator group (day  $132.6 \pm 0.24$ ) than for the control (day  $131.5 \pm 0.18$ ) and real boom groups (day  $131.6 \pm 0.17$ ). The trend was already established before the mink received the simulated booms. They were also 1 day later than the other two groups in obtaining a 40 percent level of whelping so that they would receive the experimental treatment.

The number of kits born per female whelping was not significantly different among treatments. Yearling mothers had a larger litter size than 2-year-olds, especially in the simulator group. Litter size also tended to be smaller post-boom in all treatments. This difference was not as great in the real boomed group as in the control or simulated groups. Number of kits born alive per female whelping was not significantly different for the control and boomed groups. The simulator females had fewer kits born alive ( $P < 0.05$ ) than the mothers in the controls or boomed groups because of the poorer performance of the 2-year-old mothers in the simulator group.

The number of kits alive per female at 5 and 10 days of age was not statistically different among experimental treatments. However, the 2-year-old mothers in the simulator group had poor

performance which tended to be offset by the superior performance of the yearling mothers in the same group.

Visual observation of the odd numbered nests post-boom on boom day, and the even numbered nests post-simulation on simulation day did not show evidence of disrupted nest boxes, attempts of mothers to bury kits in the bedding or undue handling of the kits by their mothers.

Mean weights of the kits at 49 days of age were not statistically different for the three experimental treatments.

No statistical difference was found among the 30 female and 30 male kits of each treatment that were raised to pelting in final weight, final body length, pelt value, and selling price.

Weights of their testes or pituitaries were not different among the mink (10 females and 10 males) from each treatment. The adrenals of the females in the boomed group were heavier than those of the control and simulator groups. The ovary weights for the boom group were significantly heavier than the controls but not from the ovaries of the simulator group which were intermediate in weight. There were no significant differences among treatments for the thyroid weights of females. The thyroid weights from males of the simulator and real boomed groups were significantly smaller than those of the control group, but were not different from thyroids of 24 normal pastel males.

General health and productivity of the animals were below average. The selection of mink recessive for the Aleutian gene (alal) and their inadvertent exposure, prior to the initiation of the study, to conditions which would cause abscesses explain their poorer performance. These effects were spread evenly throughout the different treatments and were not affected by the simulated or real sonic boom treatment.

Immediately after the first sonic boom, there was an increase in the group activity level which resulted primarily from animals engaging in activities such as peering from their nest box entrances, and entering or exiting their nest. General group activity returned to baseline levels within 2 minutes. The behavior of the females was similar in terms of the kind of behavioral events observed after the second and third sonic booms, although there was less observable reaction to these booms. The behavior of the mink exposed to real sonic booms appeared normal 24 hours later. The mink exposed to simulated sonic booms also showed the greatest change in activity levels immediately after the first boom. The behavioral events observed following simulated booms were similar to the events observed following real booms.

On the 2 test days, observers were also assigned to all sites not being subjected to the booms and at a commercial mink ranch located on the Island of Wrangell about 10 air miles south of the sonic boom test site. None of the observers heard any of the three booms. These observers detected no variation in pre- and post-boom behavior in any mink at these locations.

Other stimuli motivating the behavior of the mink at the time of reach real or simulated sonic boom appeared to have more enduring control over the behavior of the animals than did the booms. Most animals quickly returned to activities similar to those in which they were engaged prior to a given boom. Habituation occurred with as few as three real or simulated sonic booms in spite of the fact that there was a 45-minute separation between the first two booms and a 15-minute separation between the second and third booms. The duration of the startle response of the two females recorded by closed-circuit TV suggested that the startle response of nursing female mink was extremely brief in duration and the mothers quickly returned to caring for their kits. No behavioral evidence was found which would suggest that the female mink under observation in this study were sufficiently disturbed by sonic booms to engage in kit packing, kit killing, or to cease adequate lactation.

Necropsy examinations were conducted on all mink that died immediately before and after exposure to sonic booms. Gross examinations were done on 16 adult mink, 220 newborn kits, and one placenta. Tissues from all adult mink were saved for microscopic examinations, and 36 whole kits were saved as was the one placenta. Tissues were preserved in 10 percent formalin and later prepared for microscopic examination at the Armed Forces Institute of Pathology.

All of the adult mink died of fairly common spontaneous disease conditions or were killed in order to save tissues for microbiologic studies. Of the 12 adult mink (a total of 16 adult mink were examined) with significant gross lesions, six had severe gross lesions of the respiratory system, five had primary lesions of the female genital system, and one had multiple infarcts in the spleen and kidneys. Only minor gross and microscopic lesions were observed in the newborn kits, and probably all of those examined microscopically were born dead. None of the deaths could be related to the exposure to sonic booms produced by jet aircraft overflights or simulated sonic booms.

Bacterial examination of animals that died or were sacrificed likewise gave no evidence that bacterial disease was induced in the herd following exposure to sonic booms.

The females, in general, did not appear as healthy as expected. This was apparently due to the occurrence of widespread infection by pyogenic bacteria. The conditions in the females did not appear

to be related in any way to sonic boom exposure. There were no detectable differences in the overall health of the females at the three sites (control, simulated sonic boom, and real sonic boom).

Viruses did not appear to play a role in the occurrence of disease or mortality of either females or kits in the 1970 Alaskan sonic boom mink study.

The conclusion drawn from this study is that exposure of farm-raised mink to intense sonic booms during whelping season had no adverse effect on their reproduction or behavior.

DISTRIBUTION LIST

	<u>No of Cys</u>
Hq USAF/SGV, Wash DC 20314	2
AFLC/SG, Wright-Patterson AFB OH 45433	2
USAF/SGPP, Wash DC 20314	1
USAF Env Health Lab/CC, McClellan AFB CA 95652	1
AFLC/SGP, Wright-Patterson AFB OH 45433	1
AFISC/SEL/Maj John Meade, Norton AFB CA 92409	1
SAM/EDEO, Brooks AFB TX 78235	3
SAF/ILE/Dr Billy E. Welch, Asst for Env Quality, Wash DC 20330	1
SAM/AMD/Maj David Beatty, Brooks AFB TX 78235	1
USAF/PREV, Wash DC 20330	1
AFWL/DEZ-E, Kirtland AFB NM 87117	1
AFWL/DE-I, Kirtland AFB NM 87117	1
Col John P. Taylor (Ret), National Academy of Sciences, 2101 Constitution Avenue, Wash DC 20418	1
Dr. Thomas A. Ladson, Head, Dept of Veterinary Science, University of Maryland, College Park MD 20742	1
Major William McCormick 7206 Support Gp-Tuslog APO 09223 NY NY	1
Dr. William Thurston, Geologist, 4937 Crescent St, National Park Service, Bethesda MD 20016	1
U. S. Department of Agriculture, ARS/Dr. James Bond, Beltsville MD 20705	5
Mr. Ronald G. Stevenson, Director, Mutation Mink Breeders Association, Cedarburg, Wisconsin	1
Dr. G. R. Hartsough, Director, Mink Research Foundation, Pittsville, Wisconsin	

	<u>No of Cys</u>
USAF SAM/EP/Col G. Huttenhauer, Brooks AFB TX 78235	1
AFIP-Rm. G117/Lt Col F. R. Robinson, Wash DC 20305	20
Hq USAF/AFXOXYB/LtCol R. A. Jameson, Wash DC 20330	3
USAF/AFJALM/LtCol T. P. Keinnan, Wash DC 20330	35
USAF/AFRR1/Capt C. R. Currin, Naval Medical Center, Bethesda MD 20014	10