

AD-753 029

LIGHT IN THE SEA

Yu. E. Ochakovskii, et al

Foreign Technology Division
Wright-Patterson Air Force Base, Ohio

30 August 1972

DISTRIBUTED BY:

NTIS

National Technical Information Service
U. S. DEPARTMENT OF COMMERCE
5285 Port Royal Road, Springfield Va. 22151

AD753029

FTD-HT-23-105-72

FOREIGN TECHNOLOGY DIVISION



LIGHT IN THE SEA

by

Yu. Ye. Ochakovskiy, O. V. Kopelevich, and V. I. Voytov



Approved for Public release;
distribution unlimited.

Reproduced by
**NATIONAL TECHNICAL
INFORMATION SERVICE**
U S Department of Commerce
Springfield VA 22151

207

UNCLASSIFIED
Security Classification

DOCUMENT CONTROL DATA - R & D		
<i>(Security classification of title, body of abstract and indexing annotation must be entered when the overall report is classified)</i>		
1. ORIGINATING ACTIVITY (Corporate author) Foreign Technology Division Air Force Systems Command U. S. Air Force		2a. REPORT SECURITY CLASSIFICATION UNCLASSIFIED
		2b. GROUP
3. REPORT TITLE LIGHT IN THE SEA		
4. DESCRIPTIVE NOTES (Type of report and inclusive dates) Translation		
5. AUTHOR(S) (First name, middle initial, last name) Yu. Ye. Ochakovskiy, O. V. Kopelevich, and V. I. Voytov		
6. REPORT DATE 1970	7a. TOTAL NO. OF PAGES 207	7b. NO. OF REFS
8a. CONTRACT OR GRANT NO.	8b. ORIGINATOR'S REPORT NUMBER(S) FTD-HT-23-0105-72	
8. PROJECT NO. 1256		
c.	8c. OTHER REPORT NO(S) (Any other numbers that may be assigned this report)	
d.		
10. DISTRIBUTION STATEMENT Approved for public release; distribution unlimited.		
11. SUPPLEMENTARY NOTES		12. SPONSORING MILITARY ACTIVITY Foreign Technology Division Wright-Patterson AFB, Ohio
13. ABSTRACT The book cited below deals with a relatively new division of science--hydrooptics, which studies the penetration and transmission of light in the sea. The authors emphasize the importance of knowing the physical laws determining these processes, especially in connection with the solution of such an important and timely problem as the exploitation of the resources of the World Ocean. The book, written in popular science style, discusses the transmission of light in the sea, how the optical properties of the various seas and oceans differ from one another, how light originates in the sea, and the significance of marine optics for marine biology and other marine sciences. The major divisions of the book are: The Birth of Hydrooptics, The Absorption and Scattering of Light in Sea Water, Sea Transparency, Sunlight in the Sea, Why Different Seas are Different in Color, Why Vision is Poorer in Water than in Air, Marine Optics and Underwater Photography, Light and Life in the Sea, and the Conclusion. [AM1039760]		

-ia-

UNCLASSIFIED
Security Classification

14. KEY WORDS	LINK A		LINK B		LINK C	
	ROLE	WT	ROLE	WT	ROLE	WT
Underwater Light Underwater Optics Marine Biology Underwater Photography Light Scattering S and T Publication Ocean Submarine Visibility						
-ib-						

UNCLASSIFIED
Security Classification

EDITED TRANSLATION

FTD-HT-24-105-72

LIGHT IN THE SEA

By: Yu. Ye. Ochakovskiy, O. V. Kopelevich,
and V. I. Voytov

English pages: 187

Source: "Nauka" Publishers, Moscow, 1970,
pp. 1-175.

Requester: AFWL

Translated by: R. J. Zeccola

Approved for Public release;
distribution unlimited.

THIS TRANSLATION IS A RENDITION OF THE ORIGINAL FOREIGN TEXT WITHOUT ANY ANALYTICAL OR EDITORIAL COMMENT. STATEMENTS OR THEORIES ADVOCATED OR IMPLIED ARE THOSE OF THE SOURCE AND DO NOT NECESSARILY REFLECT THE POSITION OR OPINION OF THE FOREIGN TECHNOLOGY DIVISION.

PREPARED BY:

TRANSLATION DIVISION
FOREIGN TECHNOLOGY DIVISION
WP-AFB, OHIO.

Translator's Note: In the case of a great many little-known non-Russian family names occurring in this text, not mentioned in any of the standard reference works available on the subject, and where the Cyrillic rendering is at best a phonetic guide to the pronunciation, the translator can do no better than offer the most probable spelling in Latin letters. Regrettably, some inaccuracies in orthography are almost inevitable with this approach.

All figures, graphs, tables, equations, etc.
merged into this translation were extracted
from the best quality copy available.

TABLE OF CONTENTS

Designations of the Trigonometric Functions.....	iii
From the Editor.....	v
Introduction.....	vii
The Birth of Hydrooptics.....	ix
The Absorption and Scattering of Light in Sea Water.....	1
Light Becomes Heat.....	1
Why Light is Scattered in Sea Water.....	13
The Transparency of the Sea.....	27
From the North Pole to the Shores of Antarctica.....	27
The Ocean in an Armor of Ice.....	28
To the South of the Perennial Ice.....	30
Latitudes Teeming with Life.....	32
The Blue Belt of the Ocean.....	33
Transparent "Rivers" in the Ocean.....	35
"Green Soup" at the Equator.....	36
"Clouds" in the Ocean.....	38
From a White Disk to Today's Turbidimeters.....	40
Design of Modern Transparency-Meters.....	43
Marine Optics in the Service of Oceanology.....	50
Sunlight in the Sea.....	54
Light on the Surface of the Sea.....	54
Propagation of Sunlight Within the Sea.....	60
Sunlight Attenuation with Depth.....	65
Spectral Composition of Sunlight at Different Depths.....	69

Table of Contents (Cont'd)

Is There a Limiting Depth to the Penetration of Sunlight?.....	73
Polarization of Light in the Sea.....	75
How Natural Light is Measured in the Sea.....	79
Why Different Seas Have Different Colors.....	92
What Determines the Color of the Sea.....	92
Light "Returned" by the Sea.....	100
Measuring the Color of the Sea.....	105
Why We See Worse in Water Than in Air.....	112
The Eye's Ability to See in Water.....	112
Could Captain Nemo See a Half-Mile in the Sea..	120
Marine Optics and Underwater Photography.....	133
A Camera on the Bottom.....	133
Television Reporting from the Ocean Floor.....	149
Light and Life in the Sea.....	154
CO ₂ + H ₂ O + Light = Life.....	155
The Effect of Light on the Vital Activity of Marine Organisms.....	165
The Coloring of Marine Organisms.....	169
The Sea Lives - The Sea Glows.....	173
Conclusion.....	183

FOLLOWING ARE THE CORRESPONDING RUSSIAN AND ENGLISH
DESIGNATIONS OF THE TRIGONOMETRIC FUNCTIONS

Russian	English
sin	sin
cos	cos
tg	tan
ctg	cot
sec	sec
cosec	csc
sh	sinh
ch	cosh
th	tanh
cth	coth
sch	sech
csch	csch
arc sin	\sin^{-1}
arc cos	\cos^{-1}
arc tg	\tan^{-1}
arc ctg	\cot^{-1}
arc sec	\sec^{-1}
arc cosec	\csc^{-1}
arc sh	\sinh^{-1}
arc ch	\cosh^{-1}
arc th	\tanh^{-1}
arc cth	\coth^{-1}
arc sch	sech^{-1}
arc csch	csch^{-1}
—	
rot	curl
lg	log

This book deals with one of the more complex and fascinating branches of science - hydrooptics, that is, the science of the penetration and propagation of light in the sea. At the present time, a knowledge of the physical laws governing these processes is all the more essential in view of the need to find solutions to so vital and pressing a problem as the exploitation of the resources of the World Ocean. Man has begun his advance in this challenging new area. But in order that his study of the water-covered expanses of our planet be fruitful, answers must be found to a great many difficult problems of hydrooptics.

What is the explanation of the color of the sea and why do different seas have different colors? On what does the transparency of sea water depend and to what depth does light penetrate in the oceans? Why does the sea glow? The answers to all these and other questions will be found in this book.

The text has been written in a simple style, with the physical essentials of the processes discussed presented in a manner easily understood by a wide reading audience.

FROM THE EDITOR

The study of the interrelationship between the geographical distribution of optical characteristics, on the one hand, and geological, biological, and hydrological factors, on the other, is one of the most important problems in marine optics.

Since marine optics (or, as it is sometimes otherwise called, optics of the sea) is one of the branches of physics - the optics of light-scattering media - in this aspect it is related to the physics of the atmosphere. On the other hand, marine optics is quite different from atmospheric optics for the reason that there is a sharp distinction between the optical properties of the atmosphere and those of the ocean.

While optics of the atmosphere has behind it a long history, marine optics is a young science. Its intensive development dates back no further than to the postwar years. The last quarter-century has seen a sharp upsurge in man's interest in the ocean, and this has brought with it an actualization of the problem of underwater illumination and visibility. The evolution and refinement of underwater television and of equipment for motion-picture and still photography under water are other areas which have required a good knowledge of the optical properties of sea water and of the physical laws which govern the underwater penetration and propagation of light. Linked to marine optics are the

processes of the biological productivity and exploitation of the living wealth of the oceans.

At the present day, marine optics is being studied by a large number of scientific research organizations in our country. Collated works on the physics of the sea and oceanology always allot substantial attention to an analysis of optical characteristics. Meanwhile, however, there is virtually no popular scientific literature on the subject of marine optics, excluding perhaps a chapter in V. V. Shuleykin's book Essays On Physics Of The Sea and a handful of journal articles.

The purpose of Light In The Sea is to fill this void. This book discusses the nature of light propagation in the sea, tells how the optical properties of different seas and oceans differ, explains the origin of sea color, and reveals the importance of marine optics to marine biology and other sea sciences, as well as to the needs of science and technology.

V. G. Bogorov,
Corresponding Member of the Soviet
Academy of Sciences

INTRODUCTION

More than two thirds of the surface of our planet are covered by seas and oceans. In these watery reaches dwell an enormous number of fish, mollusks, and seaweed. On the ocean floor lie fabulously rich deposits of manganese and iron. It is no accident that sea water has been called "liquid ore," for the World Ocean contains in the dissolved state some eight million tons of gold, 164 million tons of silver, and an enormous quantity of other chemical elements. The mineral wealth beneath the ocean floor is literally inestimable.

Also immense are the energy resources of the ocean: the worldwide "store" of tidal energy amounts to 1,000,000 million kilowatts, while the amount of deuterium contained in sea water is sufficient to meet the energy requirements of mankind for the next billion years.

All this wealth, however, is being used in only the most limited manner. The unencompassable aquatic environment represents humanity's last frontier. The "sea age" had its beginning as recently as the twentieth century.

Man is moving ever deeper into the sea. He is penetrating it with camera and with television. The design and operation of

this equipment requires an understanding of the optical properties of sea water, along with a proper appreciation of those physical laws which determine the propagation of light in the sea. This knowledge is also important, however, for certain other scientific disciplines as well - for marine biology, for example. The fact is that life in the depths of the oceans owes its origin and existence to the Sun and to solar energy, while the basic process resulting in the entire primary production cycle of the seas and oceans is photosynthesis. Marine biologists require information on what amount of light reaches what specific depth in the sea, how light conditions differ at different levels on a daily and annual basis, and what distinguishes light penetration conditions in different waters.

The answers to these and to many other questions are provided by marine optics - a young and fast developing science, which is also the subject of this book.

THE BIRTH OF HYDROOPTICS

The essential task of this science is the study of the optical properties of sea water and the laws governing the penetration and propagation of light in the sea.

The first studies in this area were carried out as early as the beginning of the eighteenth century by the French physicist Pierre Bouguer, the creator of photometry - the science of quantitative measurements of light. Academician S. I. Vavilov considered that in the history of optics Bouguer's name deserves to stand side by side with the names of Newton and Huygens. In his famous Treatise On Optics¹ Bouguer studied a great many questions related to the measurement of light, its reflection from smooth and rough surfaces, and its propagation in a variety of media. Most of these questions bear the most direct possible relation to the sea. To Bouguer belongs the credit of having discovered one of the primary laws governing the propagation of light in the marine environment - a law which was subsequently to be known by his name. This French scientist formulated the fundamental postulates of the theory of the visibility of objects

¹Bouguer. Statistical Treatise on the Gradation of Light, Vol. III, Moscow, 1950 (in Russian).

through an illuminated turbid medium and applied this theory to the calculation of the limiting depth of the visibility of such objects under water. It was at his initiative that laboratory studies of sea water were begun.

However, if one wishes to speak of optical measurements directly at sea, here the priority belongs to the Russian investigator O. E. Kotzebue, who was the first to measure the relative transparency of the sea with the aid of submerged objects. It is to his achievements in the first half of the twentieth century and to the efforts of other Russian scientists that the science of sea light is basically indebted.

Toward the end of the last century, O. D. Khvol'son, a physicist from St. Petersburg, formulated the radiation transfer equation, the basic equation describing the propagation of light in turbid (light-scattering) media, specifically the sea. Khvol'son based his work on simple physical considerations - the conservation of radiant energy in an elementary volume of matter. In more recent times, works have appeared in which efforts have been made to establish a relationship between this equation and Maxwell's equations and thus to substantiate it from the standpoint of electrodynamics. In the period following the war the Indian scientist S. Chandrasekar and the Soviet physicist G. V. Rosenberg have updated the transfer equation in order also to take into account the polarization of the radiation.

In the beginning of the twenties of the present century the Indian scholar Ch. Raman and Soviet physicist V. V. Shuleykin succeeded in explaining the origin of the color of the sea. The Raman theory is applicable only to transparent waters, while Shuleykin's formula is more general in nature. Somewhat later, A. G. Gamburtsev developed an even more general theory; the formula he derived for light issuing from the sea encompasses the Shuleykin and Raman formulas as a particular case.

Academician Shuleykin's contribution to hydrooptics is not limited solely to his explanation of sea color. He created a theory for the multiple scattering of light in the sea, in addition to investigating the scattering of light by suspended particles and the effect of light on the coloring of various submarine algae and animal forms. At the Black Sea Hydrophysical Station which he founded at Katsiveli in 1929 studies are presently being conducted in the area of marine optics which have drawn wide attention not only in the Soviet Union, but abroad as well.

Another of the founders of modern hydrooptics is the Soviet scientist A. A. Gershun. Gershun is responsible for the theory of the light field in turbid media, which was to lay the basis for the discipline of theoretical hydrooptics. Previously, photometry had been restricted merely to an examination of the radiating and absorbing bodies themselves, while the intermediary medium (environment) in which the light propagated remained outside the analysis. Gershun introduced the concept of a radiant energy field in the medium in terms of a physical field, and also developed a supportive mathematical theory. Gershun was the first to study a wide range of important problems in the photometry of turbid media and personally devised a number of optical instruments for marine investigations. The monograph The Transparency and Color of the Sea, which he wrote in 1939 in collaboration with Vs. A. Berezkin and Yu. D. Yanishevskiy¹, remains to this day the classic work on marine optics².

¹Vs. A. Berezkin, A. A. Gershun, and Yu. D. Yanishevskiy. Prozrachnost' i tsvet morya. L., Izd-vo Voenno-morskoy Akademii VMF, 1940.

²The literature on the general subject of marine optics is extremely scanty: a chapter from the book Fizika Morya by V. V. Shuleykin, an article by Prof. S. Dantley in the Journal of the American Optical Society, and a chapter from the well known book The Sea by the American scientists J. Tyler and R. Preisendorf. It was only in 1968 that the monograph by the famous Swedish hydro-optical specialist, Prof. N. Jerlov, Optical Oceanography, made its appearance.

Among the researchers working in the area of hydrooptics abroad during the thirties and forties special mention should be made of I. Le Grand and G. Petterson. The French scientist Le Grand published several interesting works on the theory of light propagation in the sea, while Petterson, a Swede, was the inventor of numerous hydro-optical instruments and one of the first investigators to conduct optical research involving the immersion of equipment directly into the sea.

As a science, hydrooptics is classed as one of the branches of physics - the optics of light-scattering media (the same branch also includes the science of atmospheric optics). For this reason, of great importance to the development of hydrooptics were the works of a general-theoretical nature of such people as V. A. Ambartsumyan, V. V. Sobolev, S. Chandrasekar, G. V. Rozenberg, R. Preisendorf, K. S. Shifrin, and others. The methods these men formulated for the study of radiation propagation in light-scattering media bear a direct relation to the sea.

Mention has already been made of the basic equation in the theory of turbid media - the radiation transfer equation. The solution of this equation can provide us with information of interest on the light field in the sea as a function of illumination conditions and the optical properties of the sea water in a given region. The difficulty, however, lies in the fact that to date there is no complete solution to the equation as applied to the sea. The mathematical problems which such a solution entails have proven insuperable even in the face of computerized attacks. The majority of present-day hydrooptical studies are based on the findings of experimental works, which are then incorporated as building blocks in further theoretical postulations.

Experimental optical research directly in the sea has won particularly wide acceptance in the postwar period. In 1947-1948, during the round-the-world cruise of the Swedish research vessel

"Albatross," N. Jerlov conducted complex measurements in the Atlantic, Pacific, and Indian Oceans. On the basis of these measurements he formulated the first optical classification of sea and ocean waters.

Our country has also been the scene of expanded investigations into the optical properties of sea and ocean waters. During the period from 1948 through 1951 M. V. Kozlyaninov undertook extensive optical measurements in the seas washing the shores of the Soviet Union. With the commissioning of the scientific-research vessel "Vityaz'" in 1949, the P. P. Shirshov Institute of Oceanology of the Academy of Sciences of the Soviet Union (IOAN) began regular optical measurements in the seas of the Far East and in the Pacific. At the same time, under the directorship of A. A. Gershun and V. B. Veynberg, new hydrooptical instrumentation was developed in the S. I. Vavilov State Optical Institute.

Our knowledge of the optical properties of the water of the open oceanic areas of the planet was significantly broadened during the International Geophysical Year and Year of International Geophysical Cooperation from 1957 to 1959. During the preparatory period for these international events the Soviet Union created the first equipment ensemble for use in mass measurements of the optical characteristics of seas and oceans - the FPM-57 photoelectric transparency-meter (turbidimeter), the FMPO-57 underwater illumination-meter, the SGN-57 combined spectrohydronephelometer/transparometer, and the FM-46 hydrophotometer.

These years witnessed an intensive development of that branch of hydrooptics which might be referred to as optical oceanology. The purpose of optical oceanology is the study of the geographical distribution and seasonal variability of the optical properties of the waters of the World Ocean and the discovery of the relationships between optical characteristics, on the one hand, and hydrological, biological, and geological factors, on the other.

A prominent role in the genesis of the science of optical oceanology has been played by the work of I. Joseph. Using experimental material obtained for the most part from tidal studies in the North and Baltic seas, this scientist has demonstrated the existence of a definite relationship between certain optical characteristics and hydrological conditions, in addition to the fact that rather distinct optical attributes are proper to different aquatic masses.

In addition to the Swedish "Albatross," Japanese, US, and Australian research organizations have conducted hydrooptical readings in the Pacific.

Soviet specialists have made important contributions to the study of the optical properties of the World Ocean. The "Vityaz'" in the Pacific and Indian oceans, the "Mikhail Lomonosov" in the Atlantic, the "Ob'" in the Antarctic, and the "Academician S. Vavilov" in the Mediterranean and Red seas have covered vast expanses of the world's watery surface with a fine network of hydrooptical stations. Figure 1 shows a chart of the World Ocean indicating the location of such hydrooptical stations (of which 75% belong to Soviet expeditions).

Concurrently with this kind of expeditionary activity, experimental and theoretical studies are going forward in an effort to explain the light field created by natural and artificial sources. The conditions of underwater visibility are also being investigated (with great credit in this area belonging to US scientists Dantley, Tyler, and Preisendorf).

The French hydrooptical specialist A. A. Ivanoff has carried out intensive studies of the polarization of natural light, underwater visibility, and the optical properties of marine waters. The work of J. Lenoble has won wide recognition, and unquestionable interest attached to the research of A. Morel, whose area of study is that of scattering processes in the sea.

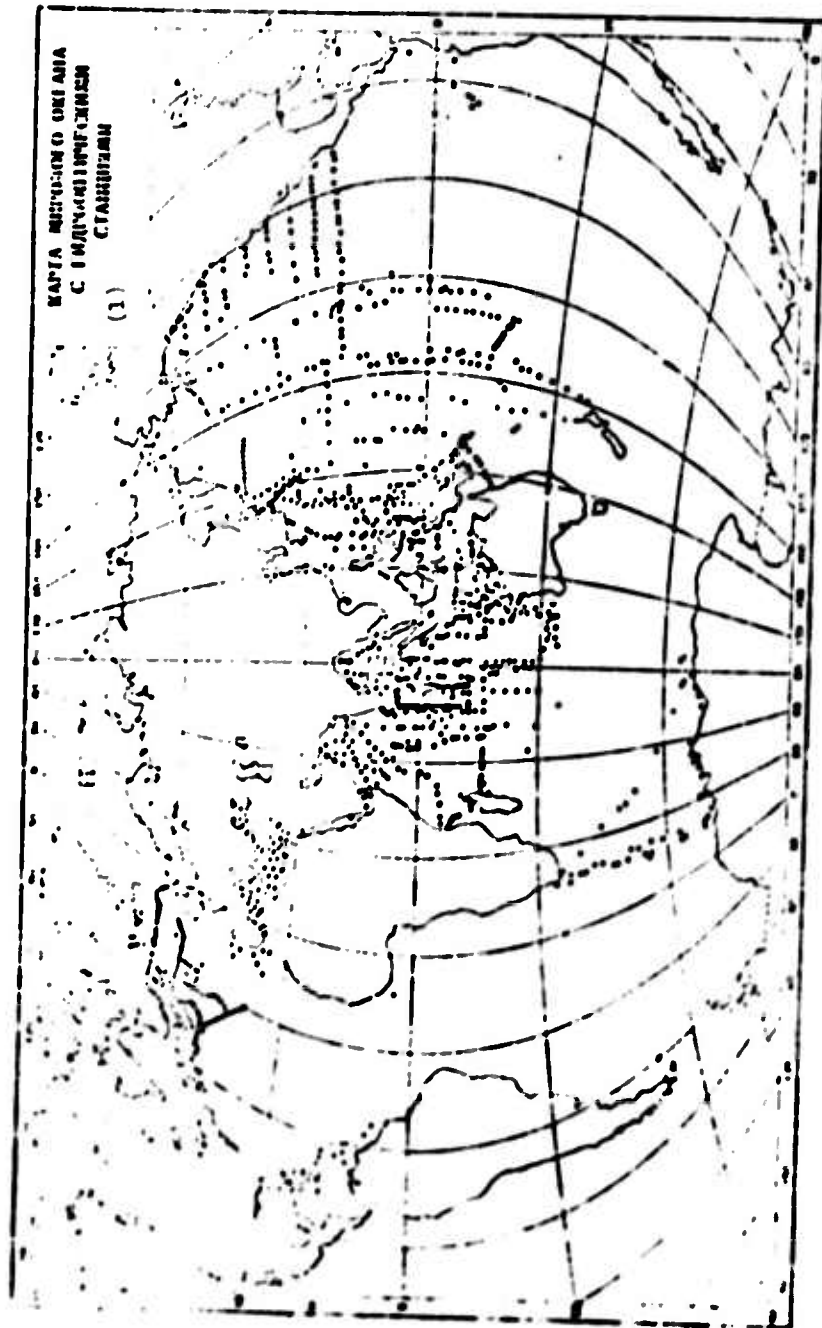

FIG. 1. (1) Chart of the World Ocean indicating the location
 KEY: (1) of Hydrooptical Stations.

Along with on-site measurements at sea, a broad-based research program has been mounted using artificial media to simulate the optical properties of actual sea water. The work conducted by V. A. Timofeyeva at the Marine Hydrophysical Institute of the Soviet Academy of Sciences and by A. P. Ivanov at the Institute of Physics of the Belorussian Academy of Sciences have provided a basis for laboratory investigations of many factors influencing the propagation of light in the ocean.

Marine optics is an organic part of a large complex of sciences engaged in the study of the physical properties of the World Ocean. Its achievements are indissolubly related to the evolution of oceanology as a whole.

THE ABSORPTION AND SCATTERING OF LIGHT IN SEA WATER

Scarcely anyone will be amazed to learn that as it travels within the sea, daylight grows fainter with increasing depth. But why does this happen? Very likely, not everyone will be able to answer this question.

How does water "fight" with a ray of light which seeks to penetrate it? What is the physical meaning or sense of the process whereby light is attenuated (weakened) by water?

To understand these things in some detail, one must become familiar with two processes whose interaction on light is that factor which results in its attenuation in water. One of these processes is absorption, the other is scattering.

Light Becomes Heat

As it is absorbed, light energy is transformed into other forms of energy, notably heat or "thermal" energy. All quite simple, it would seem. But even a single moment's reflection will bring questions: why is light energy absorbed by the sea, what is the mechanism of this process, and in what way is light transformed into heat? And it is at this point that we enter into the realm of atomic physics. To reply to these questions,

one must make the transition from the concept "light" to the concept "energy quantum," and from sea depth to water molecule.

In 1900 the German physicist Max Planck created the quantum theory of light radiation. This theory was further developed in the works of Albert Einstein, who demonstrated that the radiation, propagation, and absorption of light takes place in the form of individual light portions - quanta - that is, unique particles of light energy which were subsequently to receive the name "photons" (from the Greek word "photos" meaning "light"). What are the characteristics of these particles?

The photon exhibits many of properties of the material particle. For example, it possesses energy, an amount of motion (momentum), and mass, which can be defined as follows: energy $W = hv$; momentum $p = \frac{hv}{c}$; mass $m = \frac{hv}{c^2}$; where h is the Planck constant ($6.6 \cdot 10^{-34}$ J·s); c is the speed of light in a vacuum ($3 \cdot 10^8$ m·s⁻¹); v is the frequency with which the photon was emitted, as determined from the relation $v = \frac{c}{\lambda}$ s⁻¹, where λ is the wavelength of the light.

Nevertheless, the photon is not a material particle. The fact is that its mass is a mass of motion. The quiescent mass of the photon equals zero. In other words, a photon exists as long as it is in motion.

One other peculiarity of the quantum theory of light consists in the fact that this theory in no way denies the wave (oscillating) nature of light. As we have seen, the energy quantum is quantitatively expressed through a wave characteristic - the frequency of the light vibrations.

Myriads of photons penetrate the upper strata of the sea with the speed of light (in water this speed is 1.34 times less than in air) and carry with them enormous stores of Sun-radiated

energy. It is as difficult to imagine the number of photons present at a given moment in the ocean as it is to estimate the number of its molecules, considering that of the latter there are $3.34 \cdot 10^{25}$ in a cubic meter of water.

Still, an approximate count shows that on a sunny summer day anywhere along the southern shore of the Crimea 1 m^2 of sea surface is traversed in a single second by some $2.7 \cdot 10^{21}$ photons. Based merely on the number of photons it is difficult to arrive at an idea of the energy which they carry into the sea. The point is that photon energy differs and, in keeping with the formulas cited above, is determined by the frequency with which the photons were radiated (emitted), that is, by the wavelength of the light. Photons of different "coloration" display different energy.

Using the existing ratio, let us calculate what energy is possessed by a violet-colored photon with a wavelength of 380 nm^1 and a red-colored photon with a wavelength of 770 nm :

$$W_v = \frac{hc}{\lambda_v} = \frac{6.6 \cdot 10^{-34} \times 3 \cdot 10^8 \text{ J} \cdot \text{s} \cdot \text{m}}{380 \cdot 10^{-9} \text{ m} \cdot \text{s}} = 5.2 \cdot 10^{-19} \text{ joules} = 3.3 \text{ eV};$$

$$W_r = \frac{hc}{\lambda_r} = \frac{6.6 \cdot 10^{-34} \times 3 \cdot 10^8 \text{ J} \cdot \text{s} \cdot \text{m}}{770 \cdot 10^{-9} \text{ m} \cdot \text{s}} = 2.6 \cdot 10^{-19} \text{ joules} = 1.6 \text{ eV}.$$

¹1 nm (nanometer) = $10^{-9} \text{ m} = 10^{\circ} \text{ \AA}$.

Thus, violet light is twice as energy-rich as red light. In turn, this leads to definite differences in the interrelations of photons with water molecules. To understand the character of these interrelations and how radiant energy is transformed into heat energy, we must turn to the water molecule (Fig. 2, a).

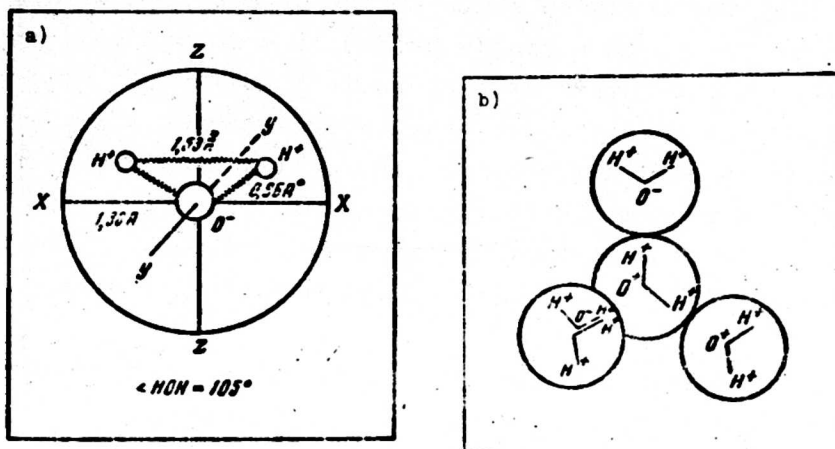

Fig. 2. Structure of water molecules (a) and their relative arrangement (b).

The molecule in question consists of two positively charged hydrogen atoms and one negatively charged oxygen atom. The atoms are arranged at the apices of an isosceles triangle and are held in place relative to each other by energy bond "springs." This kind of system possesses a definite reserve of kinetic energy and is in a state of continuous motion: the atoms on their "springs" perform elastic vibrations of a specified amplitude, while the molecule as a whole may shift and rotate with respect to any of the x, y, or z axes.

In water individual H_2O molecules tend to group themselves together into associations in the form of unique tetrahedra (Fig. 2,b). By virtue of the electrical character of the intermolecular bonds, each negatively charged oxygen atom is drawn toward a positively charged hydrogen atom. This kind of molecule contact is known as a hydrogen bond.

Let us attempt now to trace the mechanism underlying the transformation of the proton's radiant energy into other energy forms, specifically into the heat energy of molecular motion. It will be recalled that the heat or thermal energy of a body is the term used to describe the energy of the unordered motion of its molecules. The intensity of this motion is determined by the supply of kinetic energy possessed by the molecules.

Let us further imagine that one of the molecules is struck by a light energy quantum - a photon. What can happen? The molecule absorbs the photon, that is, it increases its energy by an amount equal to the energy of the absorbed photon, or, as the physicists say, the molecule is excited. Although the molecule remains in the excited state for a very brief time (approximately 10^{-8} - 10^{-9} s), nevertheless, during this period it is capable of traveling the distance separating it from an adjacent molecule in the unexcited state and of imparting to it its surplus energy.

In this way, the energy of the absorbed photon is transformed into the energy of the oscillatory, rotary, and forward motion of the molecules, that is, into thermal energy. Having collided in its motion with neighboring molecules and having transferred to them its surplus energy, our molecule again awaits a new encounter with the next photon. But does every encounter with an energy quantum end so favorably for the molecule? As it turns out, no. It is sufficient for a molecule of water to absorb a photon having an energy of 5.1 eV for it to cease to exist as a single entity. A photon of this kind disrupts the internal bonds of a water molecule and it falls apart (dissociates) into H and OH, and, if the photon energy was 9.5 eV, into H-O-H¹.

¹These figures refer to the H₂O molecule when it is in the gaseous state.

Can light in the sea cause this destruction of molecules? Fortunately, no. The fact is that the photon energy of the visible light propagating in the sea does not exceed, as we have calculated, 3.3 eV. Such a destructive effect might be caused by ultraviolet light photons which have an emission wavelength of less than 240 nm; however, as we shall learn in the discussion that follows, this light is for all practical purposes completely held back by the atmosphere and never reaches the surface of the sea. But, on the other hand, for the disruption of the hydrogen bond, that is, the destruction of the molecular associations, the energy of the visible light is sufficient, since the hydrogen bond energy is less than 1 eV.

Thus, the light penetrating into the sea causes the water molecules to be in a state of constant relocation, as they combine one with another and share the energy they have received from the photons absorbed. At the same time, the red light, with its lesser energy level, is absorbed more rapidly than the blue, with by far the greater portion of its radiant energy becoming thermal. The blue photon, with its greater energy, is capable of resisting absorption for a longer time. When it collides with a molecule, it merely alters somewhat the direction of its motion, but continues onward. Only after repeated collisions is it ultimately absorbed in one final encounter with a water molecule.

The aggregate of these seemingly infinitesimally small processes, when multiplied by the massive nature of their occurrence, is ultimately responsible for the movement of the waters of the ocean, their temperature, and the life activity of the organisms which inhabit its depths.

The absorbed energy, however, is converted not only into heat energy. Absorbed by the cells of sea-water phytoplankton, the light energy quantum causes a chemical reaction in the synthesis

of matter in the albumen molecules, resulting in a metabolic process, that is, the occurrence of a photochemical or photo-biological effect. Since, as we have already seen, photons possess different energy depending on the frequency (that is, the wavelength of the light), they are thus also differently absorbed. How can this absorption be evaluated quantitatively?

The ability of any substance to absorb light is characterized by its absorption index. Suppose that we beam a ray of light against a thin layer of matter. The number of photons (ΔN) absorbed by this layer will be proportional to its thickness (Δz) and the number N of photons striking the layer: $\Delta N = \kappa N \Delta z$.

The proportionality factor κ in this formula depends only on the absorbing properties of the substance in question and is referred to as the absorption index. From the physical standpoint, this index is equal to the probability that a photon, traveling through a layer of unit thickness in the substance, will be absorbed in this layer.

The absorption index is measured in units which are reciprocals of the units of length: cm^{-1} , m^{-1} , km^{-1} . The unit m^{-1} is used in marine optics. This index is a spectral quantity, that is, its values depend on the wavelength of the light. The ability of water selectively to absorb light of different wavelengths is called selectivity.

The degree to which the absorption indices differ for distilled water (within the limits of the visible portion of the spectrum) is evident from the following figures:

Color	Violet	Blue	Green		Orange	Red	
nm	400	450	500	550	600	650	700
m^{-1}	0.0050	0.0013	0.0025	0.015	0.091	0.15	0.26

We can see therefore that the absorption of red light is hundreds of times greater than that of blue-green. These indices, however, describe light absorption strictly by water molecules. In actual sea water this process is far more complicated, since the photons are absorbed not only by the molecules, but also by substances of organic and inorganic origin dissolved in the water. Such solutions include virtually all the chemical elements known to us. Professor N. N. Zubov has written: "...if certain of these [elements - Author] have not yet been detected, this is to be ascribed more to the inaccuracy of the methods of determination than to their actual absence¹."

Found most abundantly in sea water are the salts of sodium, potassium, and magnesium. Sea water exhibits a certain amazing property - the constancy of its salt composition. While the concentration of dissolved salts in the ocean may vary rather widely depending on local conditions, the ratio between the basic salts remains constant.

What is the difference (from the standpoint of absorbing properties) between sea and distilled water? As long ago as 1927 a number of very interesting measurements were made by the American scientist E. Halbart. Rightly reasoning that absorption in sea water is caused both by the water itself and by the salts dissolved in it, Halbart studied the molecular coefficients of absorption of NaCl, KCl, MgCl₂, MgSO₄, and CaSO₄. Based on his measurements, Halbart determined that in the visible portion of the spectrum absorption by distilled water differs only slightly from absorption in well filtered, pure sea water, while in the ultraviolet region the dissolved salts result in a sharply increased absorption index.

¹N. N. Zubov. Morskiye vody i l'dy. M., Gidrometeoizdat, 1938.

In addition to the salts, the sea also contains in a dissolved state organic substances, which increase absorption and change the selectivity of sea water (with respect to the selectivity of distilled water). This is especially true of waters with a high content of the mysterious "yellow substance." Research by scientists and primarily the fundamental studies by the German oceanologist K. Kalle have shown that the "yellow substance" consists of free carbohydrates and free amino acids formed as the result of the decay of organic substances whose end product are humic compounds which are yellow in color and are preserved in a highly stable manner in the waters of the sea. These compounds are contained in all seas and oceans, but are particularly prevalent in high-productivity regions rich in organic matter. The presence of the "yellow substance" has a significant modifying effect on the spectral absorption curve of sea water (Fig. 3). In the waters of the Baltic Sea, which are especially rich in "yellow substance," the absorption index is higher than in pure water, while its minimum is shifted in the direction of the long-wave portion of the spectrum.

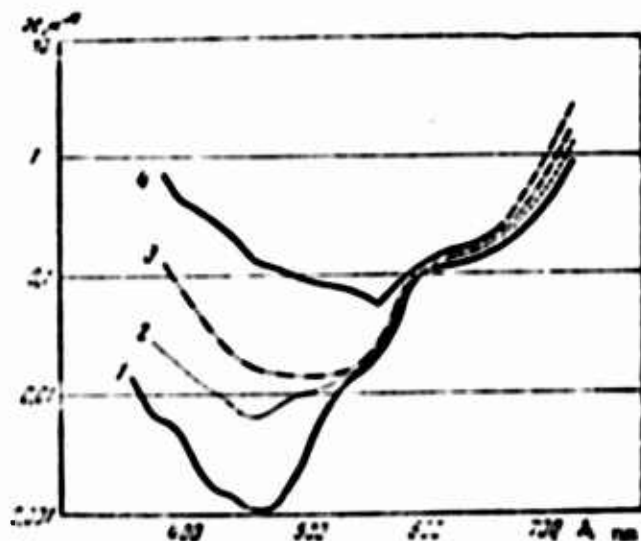

Fig. 3. Spectral curves of the absorption indices of distilled water (1), filtered sea water (2), natural waters of the Atlantic Ocean (3), and the Baltic Sea (4).

This difference in the values of the absorption indices and in their spectral distribution may have a telling effect on the temperature of the surface layer of the sea. All other conditions being equal (amount of incident energy, mixing intensity, etc.), waters with a high concentration of "yellow substance" will display better heating than the same layer of pure ocean water. Roughly speaking, turbid waters are warmer than clear waters. If an identical quantity of light energy is absorbed (that is, converted in large measure into heat energy) in a thin layer of turbid water, this layer will be heated more intensively than a thicker layer of pure water which has absorbed the same amount of energy.

In conjunction with other factors, this phenomenon is responsible for the more accelerated process of photosynthesis, that is, the formation of phytoplankton, in waters with a richer "yellow substance" content. This is one example of the interrelated causality of the processes transpiring in the sea.

In this way, then, the absorption of light in sea water is caused both by the absorption by the molecules of the water itself and by the inorganic and organic substances dissolved in that water. We have already spoken of the fact that in the visible region of the spectrum the inorganic salts have a minor effect on the absorption of light; consequently, the difference in the spectral absorption curves of sea water can only be due to a difference in the amount and nature of the organic material dissolved in the water¹.

¹We are deliberately omitting from consideration here the matter of absorption on particles suspended in the water, for the reason that these particles contribute far more to the process of light scattering than to light absorption.

The absorption index is one of the most essential hydro-optical characteristics, a knowledge of which is indispensable to the various computations involved in the propagation of light in the sea. But how is it to be measured?

More or less accurate data on the absorbing ability of water have been available since as long ago as the end of the nineteenth century. For example, Gruenfer and Albrecht, by aiming sun light into water-filled tubes, were able to determine the water attenuation of various segments of the visible spectrum. Later, O. Aufsess conducted measurements using distilled and lake water, and for a long time these experiments were regarded as classical determinations. Figures on the attenuation of light by water in the infrared spectrum were obtained by Ashkinass, while meticulous studies in the 360-to-800 nm waveband were carried out by James.

All these measurements were, as a rule, performed on water samples poured into tubes equipped with glass end-stoppers. These tubes were then placed inside spectrophotometers of various design. A light beam of specified wavelength was passed through a layer of water having a definite thickness, with the spectral absorption index computed on the basis of the ratio of the intensity of the light transmitted by the water to the intensity of the incident light.

At this point, a qualification is in order. We have already indicated that light in water is attenuated under the effect of two processes - absorption and scattering. Therefore, in absorption measurements by the methods described above there was a need to ascertain that the light which traveled through the water-filled tubes was only absorbed and not scattered.

Spectral analysis, it will be recalled, is extensively employed in studies of the content and composition of various

substances. By measuring the absorption spectrum of the system in question (that is, the dependence of the absorption index on the wavelength of the light), the composition and amount of substances present can be determined by the location of the maximum and minimum absorption values in this spectrum. As far as sea water is concerned, where scattering normally far exceeds absorption, the usual methods of spectral analysis are inapplicable. The point is that to the losses of light due to absorption there must here be added the scattering losses, which may severely distort the true spectral dependence of the absorption (Fig. 4). The determination of true absorption in a scattering medium (specifically, in sea water) is an extraordinarily difficult problem which even today is still awaiting its final solution. When measuring absorption in laboratories investigators resort to all kinds of tricks in order to collect in the receiver all the scattered light in addition to the light transmitted. One such technique was proposed in 1954 by Japanese professor Sibata. Between the receiver and the tray a scattering opal glass is placed, while the tray walls are coated with a specularly reflecting layer to increase the portion of scattered light striking the receiver. As can be seen in Fig. 4, this method affords a high degree of protection against the harmful effect of scattering.

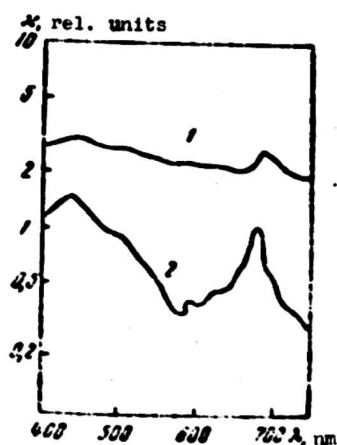

Fig. 4. Spectral curves for the sea-water attenuation of light, as measured by different instruments: 1 - conventional spectrophotometer (absorption effect completely concealed by scattering); 2 - by means of opal glass (chlorophyll absorption peaks clearly visible at 440 and 675 nm).

There also exist methods for the determination of the absorption index in scattering media which are based on the light field theory. The application of these techniques requires the immersion of the test equipment directly into the sea.

Why Light is Scattered in Sea Water

Imagine that by repeated distillations and filtrations we have succeeded in obtaining a certain quantity of water containing not even a single, most minute dust particle. This "optically pure" water we pour into an aquarium. Imagine also that the molecules of this water are uniformly distributed throughout the entire quantity and have been momentarily "frozen" in this position. Now, against one of the walls of our aquarium we aim a parallel beam of light and observe from the side. We find that nothing can be seen. All we have to do, however, is slightly heat the water, stir the molecules, and immediately the faintly perceptible beam of light passing through the water will become different. Add to the water a little dust or a few drops of milk and the light beam will now take on an entirely different appearance.

What has happened?

As long as the light was traveling through absolutely uniform water, there was no scattering and thus nothing was visible to us through the lateral wall of the aquarium. However, it was sufficient to disrupt the uniformity (homogeneity) of the medium, by heating it or contaminating it with external admixtures, and the beam at once became noticeable because of its partial scattering. How can this be explained?

As the temperature rose, the "frozen" molecules entered into motion, chaotically collecting in one place and forming "voids" in another, that is, the uniform distribution

of the molecules in the quantity of water was disrupted. Disruptions of this kind are referred to as density fluctuations of the substance.

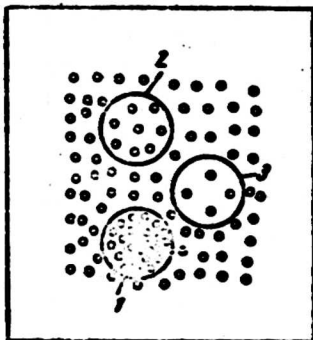

Fig. 5. Fluctuation of molecules: 1 - volume with average number of molecules; 2 - fluctuation with reduction of density; 3 - fluctuation with increase of density.

Figure 5 shows a graphic portrayal of what has occurred. When we added dust or milk droplets to the "optically pure" water, we violated the homogeneity of the water by external impurities which were then present in it in a suspended state in the form of solid particles (dust) or a fatty emulsion (milk). Thus, in the first instance what we observed was the scattering of light caused by the molecules of a substance, that is, molecular scattering of light, and in the second, scattering caused by suspended particles. It is important to note that the optical properties of these particles must differ from the optical properties of the water or else no disruption of homogeneity will occur and the light will not be scattered.

The first person to study the scattering of light by fine particles of dimensions smaller than the light wavelength was the English physicist Rayleigh. The intensity of scattering by such particles is inversely proportional to the fourth power of the wavelength. In other words, if we take violet and red light of equal intensity, there will be almost 17 times more energy in the scattered violet light beam than in the red.

If we designate as I_{90} the intensity of the radiation scattered at a 90° angle with respect to the original direction, then the intensity of Rayleigh scattering for all other directions (I_γ) will be governed by a definite law:

$$I_\gamma = I_{90}(1 + \cos^2\gamma).$$

By calculations of elementary simplicity and by graphing the scattering intensity at different angles in the form of vectors of the appropriate length, it is possible, if the ends of these vectors are united by a gradual curve, to obtain the so-called scattering indicatrix (Fig. 6). From the form of this indicatrix it is evident that in Rayleigh scattering there is as much forward scattering of light as there is back scattering, that is, the scattering is symmetrical with respect to the x and y axes. Naturally, the more scattering particles in the water, the more severe will be the scattering of the light.

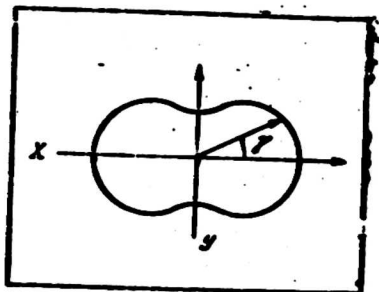

Fig. 6. Rayleigh scattering indicatrix.

In 1908 M. Smolukhovskiy voiced the hypothesis that the molecule clusters caused by density fluctuations might have the same light-scattering effect as material particles. Albert Einstein was to provide a further mathematical development of Smolukhovskiy's theory. The equations derived provided a means of calculating the magnitude of the scattering which occurs in water due to density fluctuations. The values found were so small that they could not be used to explain the scattering observed in the sea. Even in the purest ocean water molecular scattering

plays by no means the main role. How then is light scattered in the purest waters of the seas and oceans?

The answer is that these waters are pure only when admired from the deck of a ship; but place a drop of sea water under the microscope and we shall discover in it single-cell plankton organisms whose diameter is 100 times greater than the wavelength of blue light (Fig. 7).



Fig. 7. Photograph of suspended particles in off-shore waters of the Pacific Ocean.

By examining a drop of water under an electron microscope (Fig. 8) one can easily see just how dirty at first sight clean sea water actually is. It will always contain in the suspended state minute fragments of diatomic and radiolarian organisms, kaolinite, hydromica, and many other particles of organic and mineral origin.



Fig. 8. Microphotograph of the particles in an Indian Ocean water sample.

Everyone has heard of the transparency and purity of the blue waters of the Mediterranean. Marine geologists Ye. Yemel'yanov and K. Shimkus, engaged in a study of suspensions in the sea, have calculated that in 1 m^3 of Mediterranean surface-layer water there is an average content of about 1.5 g of suspended matter consisting of the particles of dead organisms and dust carried into the sea by rivers and winds. The geologists not only determined the weight of the suspension, but under a microscope counted the particles and found their distribution by size (Fig. 9). It was discovered that in a cubic meter of water there are approximately 250 million inorganic particles measuring 1-5 microns, and some 135 million organic particles. It is no accident, therefore, that from the point of view of light propagation sea water is considered a turbid medium.

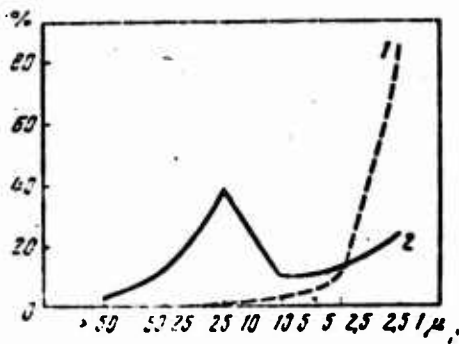

Fig. 9. Suspension particle distribution by size in Mediterranean waters: 1 - inorganic; 2 - organic.

The first detailed studies of light scattering in turbid media were conducted by the English physicist Tyndall in 1868 (this phenomenon is now known as the Tyndall effect). Later, the German scientist Gustav Mie, studying the scattering of light on particles of water-dispersed gold, developed in 1908 a theory for scattering on particles of larger-than-light-wavelength size. It was found that such "large" particles scatter light in an entirely different way than with Rayleigh scattering: a considerable portion of the scattered light is directed forward and only a small part backward, toward the incident beam. There can be

no question of any kind of symmetry. At the same time, the portion of forward-scattered light is determined mainly by the size of the particles. This is the so-called Mie effect.

V. V. Shuleykin has computed the scattering indicatrices for large particles. Several of these are shown in Fig. 10. As particle size increases, the indicatrix is stretched further and further forward. Together with this, one other curious phenomenon is observed: the scattering ceases to be governed by the Rayleigh law of inverse proportionality to the fourth power of the wavelength. Shuleykin established a relationship between particle dimensions and the exponent for λ which is to replace the "Rayleigh fourth:"

Exponent for λ	4.0	3.5	3.0	2.5	2.0	1.5
Diameter of scattering particles μ	0.07	0.1	0.15	0.23	0.30	0.35

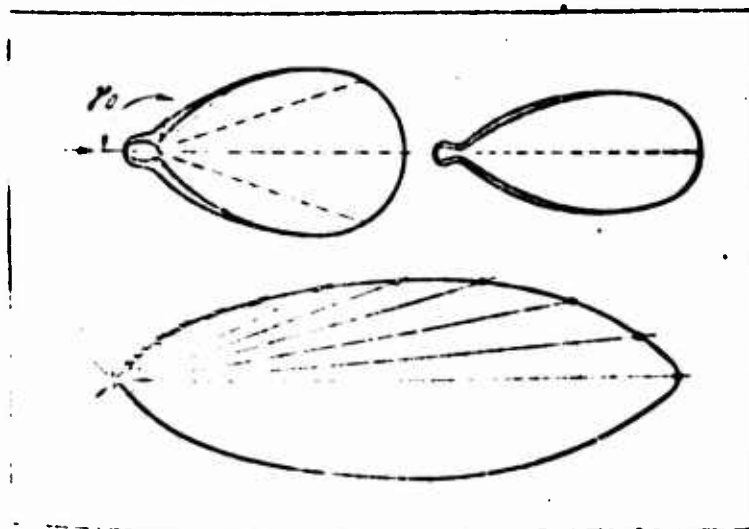

Fig. 10. Scattering indicatrices for large particles (following V. V. Shuleykin)

From these figures it is clear that if the particle dimension is about equal to the wavelength of the visible portion of the

spectrum, scattering ceases to be selective, that is, the light of all colors is scattered identically.

Up to this point, our discussion has dealt with scattering on a single particle or on a set (array) of identical particles. But what about scattering under the real conditions of the sea? How is it to be evaluated? Geologists have demonstrated in a fairly convincing way that every droplet of sea water contains an enormous quantity of the most varied particles. Likewise, consideration must be given to the fact that scattering depends not only on the dimensions of these particles, but also on the optical properties of their constituent material.

We have already spoken of the indicatrices worked out by Rayleigh and Shuleykin. But can a sea-water indicatrix be developed with an acceptable degree of accuracy?

In principle, this kind of thing is possible, but it requires a total understanding of the number, dimensions, and optical properties of the particles suspended in the sea water. Today's state of the art in this area of research cannot provide all the information we require.

By knowing the scattering indicatrix for the entire range of angles from 0 to 180°, the water-suspended particle dimensions can be studied. K. S. Shifrin's optical methods of determining the dimensions of scattering particles in various media are presently also beginning to find application in marine optics as well.

In order to determine the scattering properties of sea water, direct measurements must be conducted, either by transporting a sample of the water to a shipboard laboratory or by immersing the instrument into the sea. Instruments of this type are normally called nephelometers.

One of the first instruments of this kind was a device developed by A. A. Gershun and M. M. Gurevich at the S. I. Vavilov State Optical Institute. A diagram illustrating the measurement of scattering by this instrument can be seen in Fig. 11. Through an optical system a vessel with water is illuminated by a parallel beam of light. As in the example with the aquarium, light scattering gives rise in this vessel to a gleaming trace, the brightness of which at different angles is evaluated by a photometer through its comparison with a mat plate of known reflectance positioned in the center of the vessel. Once a series of brightness values have been obtained for various angles, one can, first, plot the scattering indicatrix and, second, compute the scattering index.

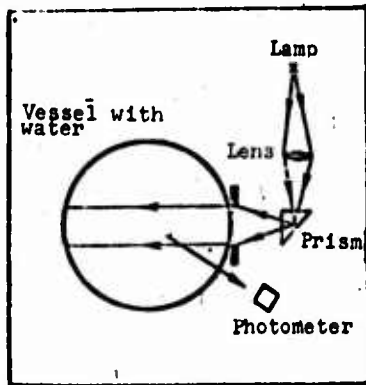

Fig. 11. Gershun-Gurevich nephelometer.

By collecting all the light scattered in the different directions, we shall arrive at the total number of photons ΔN scattered by our volume of water. Exactly as in the case of absorption, this number is proportional to the quantity of photons N falling on the layer and the thickness of the layer Δz : $\Delta N = \sigma N \Delta z$. By analogy with the absorption index, the proportionality factor σ in this formula is called the scattering index. It is equal to the probability that a photon, traversing a layer of unit thickness in a substance, will change the direction of its motion.

An original light-scattering measurement instrument was developed and used by V. V. Shuleykin. In this device the light

source was the Sun, rays from which were directed by a heliostat into a system of lenses and objectives, and from there, in the form of an intense parallel light beam, into the instrument. After undergoing multiple refraction in the bent tube of the device, the light illuminated the test volume of water at different angles, while its brightness was compared by a photometric mechanism with the brightness of a standard disk (plate).

One present-day "indicatrixometer" is the SGN-57 hydronephelometer, designed at the S. I. Vavilov State Institute of Optics under the direction of V. B. Veynberg. Figure 12 shows an external view of this instrument, and Fig. 13 its optical diagram. How are optical measurements made with it?



Fig. 12. External view of SGN-57 spectrohydronephelometer.

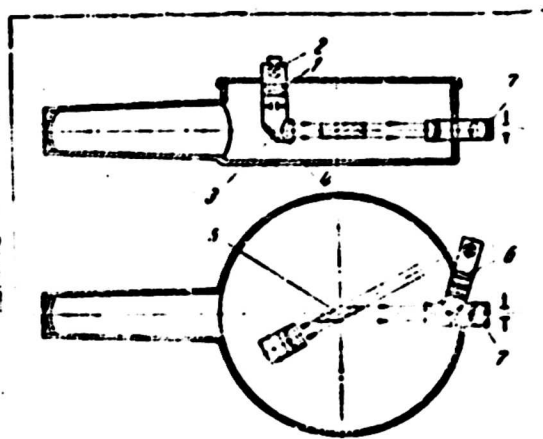

Fig. 13. Diagram of SGN-57 used as a nephelometer: 1 - optical device; 2 - light source; 3 - mirror; 4 - objective; 5 - illuminated volume of water located in observer's view field; 6 - comparison-angle illuminator; 7 - ocular.

The instrument is installed on a special bench in the ship's laboratory. Since measurements must frequently be taken with the vessel rolling, the device must be firmly secured into place. The

original intention was for the water to be pumped into the instrument from overboard through a special hose, but this was found to be very difficult to accomplish in actual practice. Moreover, only water from the uppermost surface layer of the sea could be obtained in this way...what then was to be done in the event of a need to measure the scattering ability of water, say, from the Mariana Trench in the Pacific, from depths in excess of 10,000 m or, more modestly, 1000-2000 m? The situation called for bathometers¹. But for all the scrubbing of the metal bathometers used by geologists with hot water and soap, steam, and even special chemicals, they were still too "dirty" for optical research.

At this point an engineer, A. S. Suslyayev, devised several types of "clean" bathometers from vinyl plastic (Fig. 14), affording the possibility of taking seven-liter water samples from any depth in the ocean. About five liters of the water are poured into the instrument's cell, with the remaining part of the sample used for suspension analysis or other purposes.



Fig. 14. Suslyayev hydrooptical bathometer.

¹Specially designed vessels used to obtain water samples of definite volume from any depth.

The measurements are conducted as follows. Optical device 1 concentrates the light from lamp 2 in the form of a parallel beam, which, having been reflected from mirror 3 and having passed through objective 4, strikes the water, illuminating in it a definite volume. This illuminated volume naturally becomes, as it were, a light source in itself, displaying a different brightness depending on the angle γ at which we view it. The observer, looking through eyepiece 7, balances the brightness of the photometric fields created by the illuminated volume of water and the light from the instrument's comparison-angle illuminator 6, determining the brightness of the scattered light according to a reading on a special drum. The illuminating device is rigidly connected to a disk which covers the vessel of the instrument. This disk carries degree markings. By rotating the disk, the observer illuminates the volume of water at different angles and measures the brightness. Indicatrix graphs are plotted on the basis of these measurements and the scattering index is computed. The instrument also contains colored filters to permit the taking of all readings in different regions of the spectrum.

The investigations we have described do, however, suffer from an element of artificiality. The water sample is "plucked" from its natural environment, poured into an instrument, etc., etc.. The result is something of a distortion of the natural conditions in which the light propagates. For this reason, in recent years specialists in hydrooptics have resorted more and more to scatter measurements involving the actual immersion of the equipment in the sea.

An external view of one such instrument is shown in Fig. 15. The operating principle of this meter is quite simple. During the measurements the illuminator unit 1 begins to slowly rotate with respect to the center of the scattering volume 3. With this rotation, 12 windows cut into the graduated dial of the instrument every 10 degrees pass successively in front of photomultiplier 2.

The width of these cuts is proportional to the sine of the angle, so that the scattering to be measured is created by a constant volume. We see, therefore, that this is no longer a visual, but an objective photometer in which the human eye has been replaced by a photomultiplier.



Fig. 15. External view of the Jerlov scatter-meter: 1 - illuminator; 2 - radiation receiver; 3 - axis of rotation.

In describing the measurements which he performed with this instrument in the upper layers of the sea, Jerlov noted that so great was the photomultiplier sensitivity that observations could be made only on moonless nights with all deck illumination on board the ship switched off. These measures prevented outside light from entering the photomultiplier illuminator.

More recently, devices employing lasers as the radiation source have begun to be used for scattering indicatrix measurements. This approach makes possible both a simplification of the instrument's optical system and the acquisition of an intense, directional, and monochromatic beam of light.

What do the indicatrices of sea water look like? They normally display a sharply elongated, dagger-like form (Fig. 16, 3),

thereby differing greatly from the Rayleigh scattering indicatrix (Fig. 16, 1) or the atmospheric scattering indicatrix (Fig. 16, 2). For practical computations it is more convenient to represent the scattering indicatrices of sea water in the form of graphs, as shown in Fig. 17.

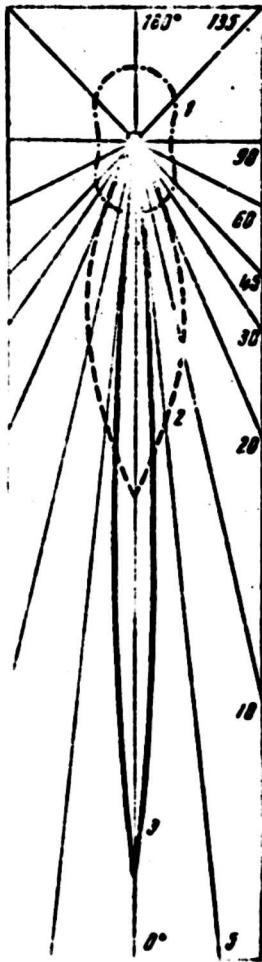

Fig. 16. Indicatrix form comparison for light scattering with Rayleigh scattering (1), in the atmosphere (2), and in sea water (3).

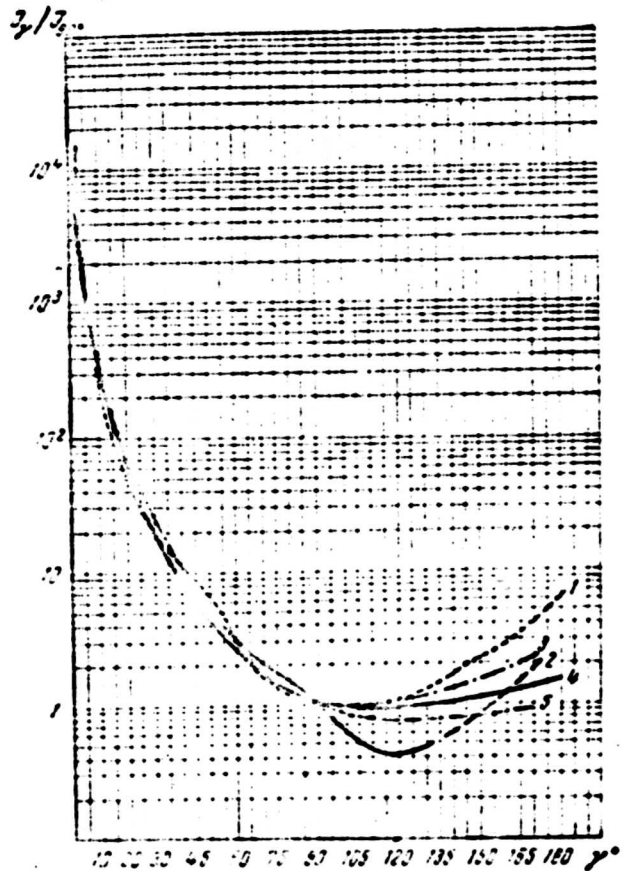

Fig. 17. Light scattering indicatrices measured in different waters: 1 - Halbart (1945), Chesapeake Bay; 2 - Koszlyaninov (1957), East China Sea; 3 - Jerlov (1961), northeastern part of the Atlantic; 4 - Tyler (1961), waters off California; 5 - Dantley (1963), Lake Winnepesaukee.

Here we see five indicatrices as measured in different waters both by laboratory instruments 1 and 2, as well as by submerged instruments 3, 4, and 5. For convenience of comparison, the 90° scattering has been adopted as the unit value. It will be noted that at angles of less than 90° the character of forward scattering is more or less the same for all waters. The intensity of the forward-scattered light is thousands of times greater than the intensity of the back-scattered light.

All that has been said above applies to scattering in a parallel beam of light directed from some sort of illuminating device. The actual process whereby the natural light traveling from the sea's surface to its depths is scattered is of course incomparably more complicated. Here we must deal with multiple scattering. As they penetrate into the sea, the solar rays at the uppermost surface layer still retain the form of directional light. With increasing depth, because of scattering, each individual ray is divided, so to speak, into many rays diverging at different angles and in different directions. In turn, these rays again divide, with this process continuing until the light has been totally scattered.

THE TRANSPARENCY OF THE SEA

From the North Pole to the Shores of Antarctica

The nature of the seas and oceans is different at different latitudes. Together with other natural features there is also a change, when moving from north to south, in the optical properties of the sea water. Even with the unaided human eye it is possible to note that the blue waters of the tropics are distinguished by their transparency from the greenish waters of the more temperate latitudes. A white disk submerged in the waters of the Pacific at the latitude of the Hawaiian Islands will still be visible at 40-50 meters, while the same disk in the Bering Sea will disappear at half that depth. In order to understand the role of natural factors in the transparency of seas and oceans at different latitudes - that is, in other words, to understand the planetary laws governing the variation in transparency as a function of the geographical zone - let us make an imaginary voyage along a meridian from the North Pole to the equator.

A geographic zonal model of the World Ocean has been worked out by V. G. Bogorov, Corresponding Member of the Academy of Sciences of the Soviet Union. The geographic zones in the ocean are similar to those which have been established for the land

masses. But there is also a significant and essential difference: on the land, zonality is observed only on the surface, at best taking in a shallow layer of the top-soil, while in the oceans zonally influenced phenomena permeate, albeit in an attenuated form, the entire mass of the oceanic depths. Each geographic zone exhibits its own specific features and its own natural peculiarities.

Studies have shown that transparency is linked in the closest way possible to the presence in the water of suspended mineral particles and plankton. In our voyage through the geographic zones we shall direct our primary attention to those natural conditions on which ultimately depends the presence of organic and inorganic particles in the waters of the seas.

The Ocean in an Armor of Ice

Fridtjov Nansen spent long months in the Arctic Ocean. He had deliberately allowed his "Fram," whose shape resembled one-half of a coconut, to become ice-bound in the drifting flows in order in this manner to reach the Pole. In winter, night reigns over the silent expanse of ice-capped ocean, the darkness broken only by the display of the polar aurora, its colored tracers trembling, fusing, changing hue, and finally disappearing altogether. Beneath the four-meter-deep layer of ice lie the black, unlit, and seemingly lifeless waters of the ocean...

Soviet biologists were subsequently to discover life at all depths of the Arctic Ocean - if not in great profusion, at least a glimmer. Most favorable, of course, to the vital activity of the marine organisms is not the winter with its extended night, but the summer with its polar day and a sun that refuses even to drop behind the horizon. But sunlight does not easily reach the lower reaches of the ocean.

As early as 1934 A. V. Trofimov measured the illumination below the ice. He found that only about 2% of the light incident to the surface remains beneath the ice cover. During the summer season, however, this cover is not a continuous one; here and there areas of open water appear. Specialists have calculated that at the height of the summer such open-water areas (or polynias, as they are called) account for some 10% of the entire area in the Arctic Basin. Naturally, life in the polynias is more intense. First there is the development of microscopic algae - phytoplankton - later followed by tiny prawnlike organisms - the zooplankton. The concentration of phytoplankton is normally far greater than that of the zooplankton, so that it is the former together with fragmented dead particles (detritus) that is fundamentally responsible for the transparency of the open ocean.

As a rule, the zooplankton clusters, which show up quite clearly on echograms in the form of a "false bottom," are not reflected on recordings showing the variation of transparency with depth. Conversely, phytoplankton-rich layers, although an excellent subject for the tracing device stylus, cannot be detected by echosounding.

The effect of the great Siberian rivers, carrying northward large amounts of suspended organic and inorganic matter, is limited to the shelf seas, the turbid-brown fluvial streams standing out clearly against the background of green and blue-green sea water. For experienced polar captains such river currents provide useful navigational markers.

The famous oceanographer and polar specialist N. I. Yevgenov recalls: "Once, on the 'Malygin,' after a difficult passage with a group of vessels from the Kara expedition through the ice between Novaya Zemlya and Yamal, we reached a stretch of clear water. We were not exactly certain of our position. We could only assume that we were somewhere in the region of Belyy Island,

but we were searching in vain through our glasses from some sign on the island - the horizon was covered with mist, the sea's surface stretching with unbroken monotony all around us. Suddenly the skipper, leaning over the railing of the bridge, began to peer fixedly at the water. 'What are you looking at, Dmitriy Timofeyevich?' I called out to him. For a moment the captain was silent, and then with the tone of a man well satisfied he replied: 'The water's turned brown. We've come into the waters of the Ob'...'.

The Antarctic Basin is also fed by the warmer and at the same time more salty and pure waters of the Atlantic, which form a strong deep-lying current.

Thus, the transparency of the waters of the Arctic Ocean is directly dependent on summer photosynthetic activity and exhibits a seasonal behavior. However, even at the peak of the biological summer the amount of phytoplankton is too small to noticeably cloud the water. It is no wonder that the oceanologist Lafond, a participant of the cruise of the American submarine "Skate" beneath the Arctic ice, reported that near the Pole "the water is extraordinarily transparent, perhaps more transparent than anywhere else."

To the South of the Perennial Ice

The surface of the seas washing our country from the north is virtually ice-free in the summer. Only here and there are individual drifts to be seen in the blue-green waters. In May and June in these areas one can observe a "florescence" of seaweed. The conditions are altogether suitable. Sunlight abounds, and the energetic intermixing of the layers which occurs in the fall and winter supplies the surface waters with nutritive salts. Heated

¹N. I. Yevgenov. Morskiye techeniya. M., Gidrometeoizdat, 1954.

by the solar rays and mixed by the wind, the uppermost aquatic stratum is separated, as it were, from the remaining mass of the water by a sharp temperature differential - the so-called temperature jump. It is above this dividing line that the plankton accumulations are normally observed. These organisms, acting as microscopic scatterers of light, cause a perceptible attenuation in the rays of the sun. For this reason, in marine optics layers with a high concentration of these minute denizens of the deep are usually referred to as optically scattering layers. Such layers may be thin or they may be several tens of meters in thickness. O. A. Sokolov observed from the porthole of the scientific-research submarine "Severyanka" an abundance of plankton in the Bering Sea at depths of 20-75 m.

"... Depth 20 m. The water has become emerald green. Underwater spring was at its height, with tiny algae in bloom.

"40 m. It is becoming darker and darker. The boat continues to dive smoothly and quite rapidly...

"45-50 m. The lights have been turned on, revealing a magnificent view, a spectacle that can't be seen in ordinary life above the water. It seems to be snowing, only in the opposite direction. Caught in the rays of the searchlights, the plankton clusters glided upward past the porthole. The boat continues to dive.

"75 m. The natural light has virtually disappeared. The water has become more transparent..."¹

Within a week or two after the "florescence" of the plankton in the Bering Sea, fine bottom details become marvelously visible

¹V. G. Azhazha, O. A. Sokolov. Podvodnaya lodka v nauchnom poiske. M., "Nauka," 1966.

at depths of 70 to 75 m, with the complete possibility of distinguishing the species of plants and animals. Near the shores, the transparency of the sea is affected by turbid river waters, and at the shallow banks - by fine bottom sediment and deposits stirred up by the wind and tide.

Latitudes Teeming with Life

In the northern Atlantic Ocean, where the cold subarctic and warm Atlantic waters meet, hydrologists distinguish the so-called polar front zone. This front reveals itself not only by its hydrological properties; meteorologists have also noted a marked air temperature difference on either side.

In the spring the polar front is also very conspicuous for its transparency, as it forms the line of demarcation between the turbid waters of the Atlantic and the clearer waters of the subarctic. During this season, the Atlantic waters are the scene of an intensive "florescence" of phytoplankton, with the result that there is a sharp decrease in their transparency. V. G. Bogorov notes that it is precisely at the temperate latitudes of both hemispheres that life is most abundant in the spring season.

During the other seasons the reverse pattern is observed: the transparency of the Atlantic waters is higher than that of the subarctic. As early as the beginning of the present century Academician N. M. Knipovich noted that five blue transparent Atlantic streams (the "Knipovich five") stand out distinctly against the background of the greenish waters of the Bering Sea. As in the subarctic zone, the temperate latitudes are characterized by the presence of optically scattering layers.

The Blue Belt of the Ocean

Seamen of the sailing vessel era, in their crossings of the tropical latitudes, used to curse the lengthy calms they encountered in this region. Frequently the sails would hang limply in the hot, motionless air, and even the proud clipper ships, capable on occasion of developing speeds of up to 18 knots, would be hopelessly becalmed in these bluest and least mobile waters of the ocean. It is to this absence of wind and to the burning rays of the sun that these latitudes owe their own unique and distinctive character.

Because of the severe evaporation the salt concentration in the water here is higher than the ocean mean. However, at the same time the water is very warm and, consequently, comparatively light. The faint winds can cause only a slight mixing effect on the mass of water, in which there are few biogenic elements. This is the least fertile ocean "soil." It is no wonder then that it yields a very scant phytoplankton "harvest." J.-Y. Cousteau and F. Dumas were amazed at the extraordinary conditions of underwater visibility they encountered off the deserted island of Selvagen Grande situated in the tropical Atlantic between Madeira and the Canary Archipelago. Swimming on the surface of the sea, they were able, through their masks, to study the ocean floor at a depth of 30 meters.

"There was no indication that a dense mass of water separated us from the bottom. On the floor there was not a single pebble nor the faintest trace of animal or vegetative organisms. The adjective 'transparent,' which implies excellent visibility at a distance comparable with the length of a good-sized concert hall, would clearly be an understatement here. The underwater landscape stood out with frightening clarity¹."

¹J.-Y. Cousteau, F. Dumas. The Silent World. M., "Molodaya gvardiya," 1957 (in Russian).

A particular place in the subtropical belt of blue and transparent waters is occupied by a remarkable shoreless sea - the Sargasso Sea. As recently as the middle of the last century the Sargasso Sea was seriously spoken of as an enormous whirlpool and trap for sailing ships. It was also pictured as an immense floating plain of dense and continuous seaweed, untraversable without fouling a ship's propellers. In fact, although certainly abundant, the seaweed does not form a continuous cover. For each square kilometer there is an average of ten to twenty thousand clusters of seaweed measuring 20-40 cm. Meanwhile, there is 30-70 times less plankton in the upper layer of the Sargasso Sea than in the Norwegian Sea.

For specialists in hydrooptics the Sargasso Sea is considered the standard of transparency. About 30 years ago, the German oceanographer H. Dietrich wrote that in terms of its optical properties the water of the Sargasso Sea is virtually identical to distilled water.

Professor N. N. Zubov has graphically called the surface stratum of this sea (0-150 m) the "production workshop of the ocean." It is in this layer that there occurs the process of photosynthesis and the birth of the phytoplankton which are most effective in clouding the water in the open sea. Naturally, the transparency in the surface stratum is somewhat less than in the underlying layers.

On the other hand, the American biophysicist G. Clark has reported that he discovered in the Sargasso Sea an anomalous pattern of transparency - very high transparency in the upper reaches (0-200 m) with a reduction in transparency at the lower depths.

In 1960, optical measurements were conducted in the Sargasso Sea from on board the Soviet research instrumentation vessel

"Mikhail Lomonosov." These measurements failed to substantiate Clark's conclusions. Because of the presence of a small amount of phytoplankton, the surface layer (0-150 m) was somewhat more murky than the waters beneath. However, even in the surface layer the transparency of Sargasso Sea water is very high, particularly in the blue-violet region of the spectrum, as a consequence of which the water takes on a deep blue-violet shade.

Transparent "Rivers" in the Ocean

The trade currents which cross the oceans from east to west at the tropical latitudes are the most powerful and longest currents of the World Ocean. They carry enormous masses of transparent water. In the Pacific the trade current flows by a large number of coral atolls, and although poets have long sung of the blueness and crystalline transparency of their lagoons, the fact is that such atolls act as sources disturbing the homogeneity of the clear trade currents. On the lee side of the atolls there is a discharge effect in the trade streams, marked by the occurrence of a restricted zone in which the deeper-lying waters rise toward the surface, ultimately leading to an abundance of plankton. Stretching from this source along the trade current is a kind of unique turbid "tail," which breaks off some 30 to 50 miles from the productive zone. On transparency charts these turbid water formations look like comets with the head near the atolls.

In the tropical latitudes, as indeed in the subtropical, seasonal variations in transparency can be disregarded, for the reason that here there are no seasonal changes in the arrival of sunlight (as in the northern latitudes). Regardless of the time of the year, a man living in the tropics loses his shadow at noon: all year long the sun stands high in the sky. The development of phytoplankton is likewise a year-round occurrence. Nevertheless, biologists have observed the existence of a relationship between the wind and the phytoplankton population. At a certain season

of the year the trade current intensifies, resulting in a more energetic mixing of the water layers, this being favorable to the development of phytoplankton. Its population undergoes something of an upturn, but not for very long. The control factor which holds the phytoplankton to its customary level is the zooplankton. Minute tropical life forms quickly appear behind the phytoplankton and momentarily consume it. This eruption of phytoplankton is of very brief duration, with the population rapidly returning to its normal level.

"Green Soup" at the Equator

The American researcher Beebe has written that, because of the abundance of plankton, the water at the equator has the consistency of a soup. Of course, this is an exaggeration, but the amount of plankton here is in fact extraordinarily large. What simply seems unusual is the sudden increase in the plankton population against the blue background of life-poor waters stretching northward and southward from the equatorial belt.

Compared with the tropical latitudes, the disappearance depth of the white disk decreases here by 10 m, with the color of the water turning light blue. The cause of the perceptible increase in the plankton population at the equator is to be found in the ascent of the deep-lying waters with their rich nutritive salt content. This is the so-called zone of equatorial divergence¹. On transparency charts, plotted according to measurement data supplied by accurate equipment, these oceanic divergence zones stand out clearly as low-transparency strips.

¹Divergence refers to the boundary or boundary zone between oppositely directed streams within cyclonic cycles.

Our "voyage" comes to an end at the equator. Were it to continue into the Southern Hemisphere, we would see that geographic zonality is expressed in the same way here as in the Northern. However, the presence in the Southern Hemisphere of the planet's primary "refrigerator" - the Antarctic continent - plus a circular drifting flow in the surface waters, results in a certain mixing of the zones.

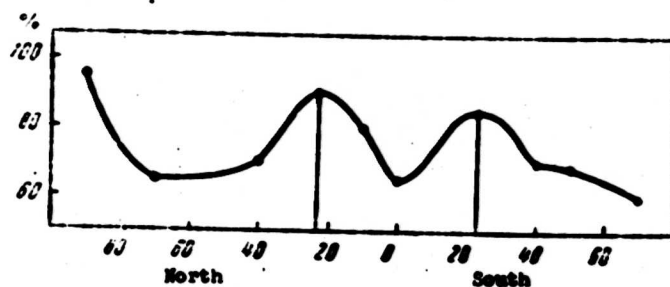

Fig. 18. Sea water transparency variation at different latitudes.

Figure 18 shows the variation of water transparency on the surface of the World Ocean as a function of geographic latitude. In the lower depths of the seas the phenomena associated with zonality are observed in a highly attenuated form; indeed, it is not possible even to discern the same number of natural zones as on the surface. For example, V. G. Bogorov distinguishes three zones in the Pacific for depths greater than 500 m: subarctic, tropical, and antarctic.

Living phytoplankton is no longer encountered in the abyssal waters¹. With respect to the zooplankton, its biomass falls off noticeably with increasing depth. Thus, in the deepest depression

¹As the result of comparatively recent investigations, proof has been found for the existence of deep-water flora. This is mainly flagellate and cyanophyceae algae possessing the capability of assimilating, without the help of solar energy, the organic matter present in solution form in the sea water.

of the World Ocean, the Mariana Trench, zooplankton values are a thousand times lower than in the 0-500-meter layer. Among the suspension components which affect the transparency of the water the principal role is played by the remnants of dead phyto- and zooplankton along with various inorganic particles. In their overall mass the abyssal waters are far more transparent than the surface waters.

Seemingly, the most transparent water should be encountered in the enormously deep trenches and depressions of the oceans. However, according to the readings of M. V. Kozlyaninov in the Izu-Bonin Trench, the waters at the extreme depths are more turbid than the surface waters. The probable cause of their turbidity lies in the sliding of fine bottom sediment from the rocky ridges surrounding the trench.

In recent years one other very interesting phenomenon has been discovered - benthonic (bottom) sedimentary flows. In this way, there may be a reduction in transparency near the ocean floor because of the roiling effect of particles laying down fine bottom sediment.

"Clouds" in the Ocean

In our discussion of the geographic zones of the Northern Hemisphere we spoke of particle accumulations - optically scattering layers. In certain regions of the World Ocean, not one such layer occurring above the temperature jump is observed, but several. There are also layers which stand out in the mass of water by virtue of their high transparency.

"On one occasion we were swimming above an underwater cliff in the Mediterranean," writes Jacques Cousteau. "The water was so cloudy that visibility was limited to a few yards. Two fathoms

lower we suddenly encountered a completely transparent layer. This gave way to a fifteen-foot stratum of milky-tinted water where visibility was approximately five feet. Beyond this milky area the water was clear down to the very bottom. A great multitude of fish were scurrying about in this twilight transparency, while the foglike shroud overhead was reminiscent of low-hanging clouds on a rainy day. Frequently, in our deep dives, we would traverse oddly alternating layers of turbid and transparent water...¹"

During February and March of 1952 the scientific research vessel "Gauss", using a photoelectric transparency-meter (turbidimeter) mounted in the hull of the ship, conducted a continuous recording of transparency along a run extending 2100 miles in the southern area of the North Sea. Concomitantly, samples were taken every other mile of the plankton and suspended matter. Rarely did the transparency curve on the recordings follow a straight line; as a rule, the monotony was broken by isolated surges as the "Gauss" cut through small clusters of plankton. The impression was that of a clear blue sky beneath the keel, dotted with occasional clouds. Closer in to the shore, these clouds seemed to flow together, forming a continuous stratus-like cover.

In coastal regions a factor greatly influencing transparency is suspended inorganic matter - particles of terrigenous origin. The German investigator Klaus Wirtkie, after recording the transparency of the water in the coastal region of the Baltic, while at the same time counting by means of a microscope the number of mineral particles and phytoplankton cells in the samples, concluded that near the shore the phytoplankton has absolutely no effect on the transparency value.

¹J.-Y. Cousteau, F. Dumas. Ibidem.

Normally, this coastal strip is quite narrow. It would seem that it should undergo a considerable widening in the vicinity of the estuaries of rivers carrying a mass of particles into the sea; however, specialists of the Institute of Oceanology have established that the effect on the optical properties of sea water of such major rivers as the Nile and the Ganges extends out at best to less than a hundred miles, with the turbid river waters sharply delineated from the transparent waters of the sea. In addition to the particles carried by the rivers, the terrigenous particles also include those of eolian (wind-borne) nature. Anyone who has visited the coasts of West Africa in the winter will never forget the enormous red disk of the sun as seen from that region. The reason for its unusual color lies in the fact that the air is saturated with the fine reddish dust of the Sahara. Rising above the desert and caught up by the trade winds, this dust is carried far out into the Atlantic. Even at distances of as much as several hundred miles from the coast of the African continent this dust fog may occasionally become so dense as to cut down the visibility within it to 1.5-2 miles. Dust particles from the Arabian Desert are transported by the winds quite far out into the Indian Ocean. These, however, are anomalous effects; normally, particles of eolian origin settle on the water in the immediate vicinity of the shoreline.

The coastal zone, or strip, makes up only 2-3% of the area of the World Ocean. The predominant role in the attenuation of light over the remaining vast expanse of open seas and oceans falls to the phytoplankton.

From a White Disk to Today's Turbidimeters

There are cases in history when what was originally considered merely a curiosity has ultimately become a generally recognized

scientific achievement. This was also true of the method of visually observing sea water transparency devised by Kotzebue, whose idea it was to lower ordinary dining-room plates overboard on a cable and track the depth of their submersion at various localities in the Pacific Ocean. At the present time, observations using a standard white disk, 30 cm in diameter, are a part of many oceanographic and hydrographic investigations. In the technical literature, especially in western technical literature, this is frequently known as the Secchi disk. In 1865 Father Secchi together with Captain Cialdi conducted numerous observations in the Mediterranean with both white and colored disks. Some time later, the Swiss geographer F. Forel proposed that the white disk be known as the Secchi disk. While in no way denigrating Secchi's role in establishing and developing the method, the white disk should rightfully nevertheless have been named in honor of Kotzebue.

In the nineteenth and early twentieth centuries visual observations of sea water transparency were carried out on an extremely irregular basis, and it was only some forty years ago that this technique was rather extensively developed to cover many areas of the World Ocean. Presented below are some approximate data on the maximum depth of white-disk visibility:

<u>Sea, ocean, bay</u>	<u>Greatest depth of white-disk visibility, m</u>
White.....	8
Baltic.....	13
Barents.....	18
Black.....	25
Bengal.....	45
Indian.....	50
Pacific.....	52
Sargasso.....	66.5

The reader will note that the recorded depth of visibility for the white disk is achieved in the Sargasso Sea. In the last 40 years tens of thousands of such white-disk measurements have been conducted.

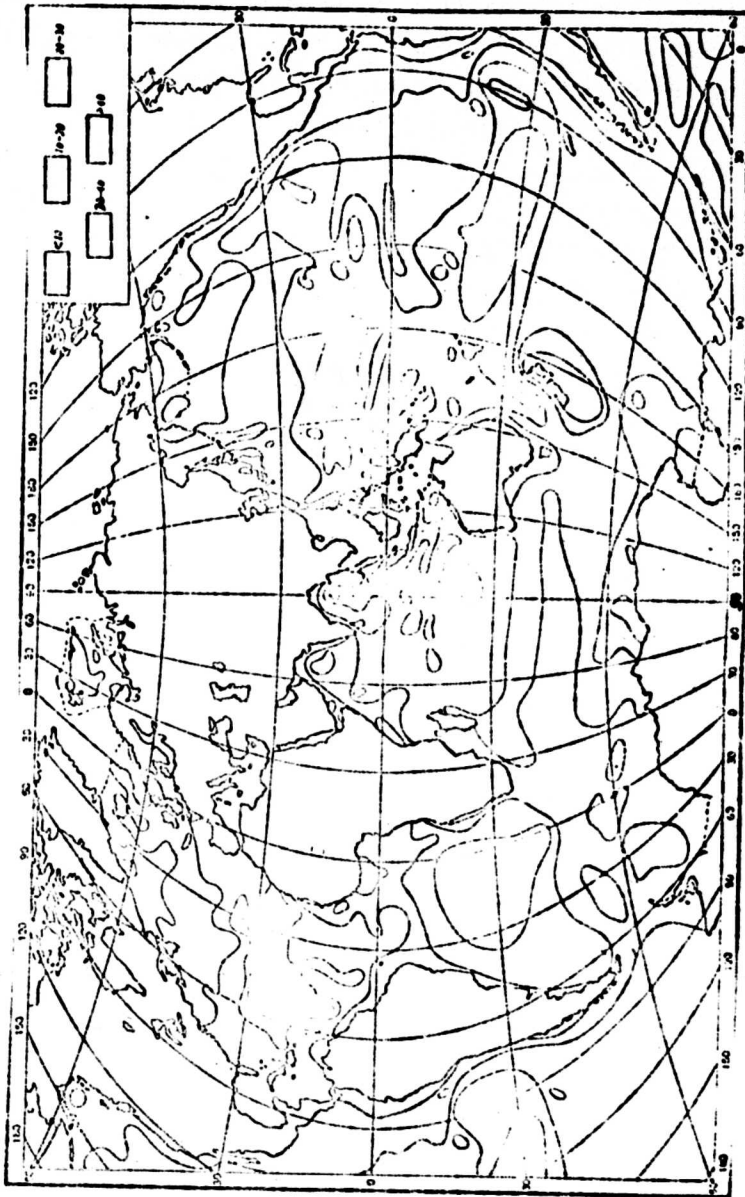

Fig. 19. Chart of the relative transparency of the waters of the World Ocean, compiled by white-disk measurements (disk-disappearance depth in meters).

At the Institute of Oceanology the results of these measurements are compiled for the purpose of developing a detailed chart of the World Ocean. Figure 19 shows only a preliminary variant of such a chart. The further accumulation of new data will certainly result in its upgrading and refinement.

A total of thirty-seven thousand white-disk readings were employed in the compilation of this chart (a point to note here is that the depth of visibility of the white disk does not constitute a strict quantitative characteristic of transparency, although it is very largely determined by this factor).

In marine optics the term relative transparency has been adopted for the depth of visibility of a white disk.

In our further discussion we shall take up the question of the physical causes responsible for the depth of white-disk visibility in different waters, but for the time being let us turn to the matter of absolute transparency measurements.

Design of Modern Transparency-Meters

In our voyage through the geographical zones of the World Ocean we spoke of "more or less transparent" waters and of layers of "higher and lower transparency," but nowhere did we present qualitative estimates of this transparency. Nevertheless, there exists in hydrooptics a strict definition of the concept "transparency."

Let us direct against a layer of water one meter thick a parallel beam of light so that it falls perpendicularly to the surface of this layer. Expressed in percentages, the ratio of the light flux transmitted through the water ϕ_z to the value of the incident flux ϕ_0 is referred to as the transparency¹:

¹Translator's Note - The terms "transparency" and "transmittance" have been used interchangeably as equivalents in this translation.

$$\theta = \frac{\Phi_z}{\Phi_0}$$

The transparency θ is uniquely related to another physical characteristic - the attenuation index.

We already know that when a parallel beam of light passes through a thin layer of water, part of the photons are absorbed and part are scattered, that is, they alter the direction of their motion. The number of absorbed photons equals: $\Delta N_{\text{abs}} = \kappa N_0 \Delta z$, while the number of scattered photons is $\Delta N_{\text{sca}} = \sigma N_0 \Delta z$, where N_0 is the number of incident photons; Δz is the thickness of the layer; κ and σ are, respectively, the absorption and scattering indices. The total number of photons forfeited by the beam in this layer equals the sum of the absorbed and scattered:

$\Delta N_{\text{tot}} = \Delta N_{\text{abs}} + \Delta N_{\text{sca}} = (\kappa + \sigma) N_0 \Delta z = \epsilon N_0 \Delta z$, where $\epsilon = \kappa + \sigma$. The proportionality factor ϵ in this formula is called the attenuation index. This index is equal to the sum of the indices of absorption and scattering. The value of the attenuation index depends on the properties of the medium in question and is one of the physical characteristics of that medium. Such values, just as those of the absorption and scattering indices, are usually given in reciprocal meters (m^{-1}).

How will the light beam change after it has traveled the distance z in the medium? Let us break this distance down into a set of fairly small segments Δz , in each of which the attenuation will equal $\epsilon \phi \Delta z$, where ϕ is the value of the light flux at the beginning of this segment, following which let us sum the attenuation on all these segments. It is possible to show that, having covered the distance z in the medium, the light flux will equal $\phi_z = \phi_0 \cdot e^{-\epsilon z}$, where ϕ_0 is its initial value. The exponent base in this formula - the number e - is referred to as "natural" and is widely used in higher mathematics. This is an irrational number, its approximate value being 2.72.

It is frequently preferred to deal with the normal base 10. In this case, our formula retains its form: $\phi_z = \phi_0 \cdot 10^{-\epsilon'z}$, but the attenuation index here is no longer the same; its value is 2.3 times less than the attenuation index ϵ (the natural base exponent). The formula $\phi_z = \phi_0 \cdot 10^{-\epsilon'z}$ makes possible a more graphic understanding of the physical sense of the attenuation index: ϵ' is a quantity which is the inverse of the distance the light beam must travel in the medium in order to undergo a 10-fold attenuation. Using this formula, the relation between the attenuation index and the transparency can be easily found:

$$\theta = \frac{\phi_{z=1}}{\phi_0} = e^{-\epsilon} = 10^{-\epsilon'}$$

And conversely,

$$\epsilon' = -\lg \theta.$$

The law of the attenuation of a beam of light as a function of the distance it has traveled in a medium was discovered by Pierre Bouguer. Its significance is enormous, extending far beyond the realm of photometry. Bouguer's law governs the attenuation of any direct energy flow, whether it be X-rays or gamma rays, electrons, neutrons, or any other particles. Careful studies conducted by Academician S. I. Vavilov have shown Bouguer's law to be valid over a very wide range of light intensity variation 10^{-14} to 10^5 joules \cdot s \cdot m² (that is, approximately 10^{20} times). Deviations from this law have been successfully detected only in substances with very protracted molecular excitation state durations (for example, in uranium glasses) or in the case of light beams of extraordinarily high power¹.

¹The generation of such beams has become possible with the development of lasers. The investigation of such phenomena is the subject of a special branch of optics - nonlinear optics.

In essence, Bouguer's law may be stated as follows: the attenuation of light on a path consisting of several finite segments is equal not to the sum, but to the product of the attenuations on each of these segments (in Bouguer's formula this fact is underscored by the fact that the optical pathlength - that is, the product of the attenuation index ϵ and the segment length z - is found in the exponent).

The operating principle of modern transparency-meters is based on Bouguer's law. In these instruments a measurement is made of the light flux transmitted through a water layer of definite thickness (l). By comparing the value of this flux with the quantity of the incident light, the attenuation index can be easily determined:

$$\Phi = \Phi_0 10^{-\epsilon l},$$

whence:

$$\epsilon = -\frac{1}{l} \lg \frac{\Phi}{\Phi_0}.$$

Transparency-meters (also called turbidimeters) may be divided into two basic groups: instruments used to measure transparency (transmittance) directly in the sea (instruments in situ), and instruments which provide readings from water samples either on board the ship or in a permanent laboratory.

The equipment of the first category is designed for vertical sounding in the ocean or for continuous recording of light transmittance at a given level with the vessel under way. The first underwater transparency-meter model was created in 1922 by N. N. Kalitin using photocells with external (normal) photoelectric effect. Ten years later, with the emergence of blocking-layer

photocells, specifically of the selenium variety, G. Pettersson developed a photoelectric transparency-meter which won wide acceptance in oceanographic research. Pettersson's device took the form of a sealed chamber accommodating a light source (lamp) and a receiving photocell, as well as a mirror mounted at a distance of one meter. After passing through a lens, the light from the lamp exited into the water in the form of a slightly diverging beam and struck the mirror set up one meter from the chamber. The light reflected from the mirror was returned to the photoelectric cell.

The Pettersson transparency-meter was subsequently improved by I. Joseph. In his instrument there are two sealed chambers. One of these chambers houses a collimated light source (incandescent lamp with a lens and diaphragm) and a control photocell; located in the second chamber are a condenser lens and diaphragm to prevent daylight from striking the receiving photocell also found in this chamber. A disk with colored filters is set up between the lens and the diaphragm. Both chambers are rigidly interconnected by a tube with slots admitting the free entrance of sea water.

In principle, the transparency-meters later developed both in this country and abroad were no different from these instruments (with the exception that photomultipliers began to be used in place of the photocells). An external view and optical diagram of one photoelectric transparency-meter (FPR) are shown in Figs. 20 and 21. The design of this instrument and of its subsequent modifications was worked out under the direction of A. K. Karelin.

Interesting examples of photoelectric transparency-meters were developed by G. G. Neuymin and A. N. Paramonov. One of these (the MIFP-3) permits transmittance soundings to a depth of 2000 m. While all the aforementioned instruments were cable-connected to the shipboard laboratory, the MIFP-3 employs a telemetry or acoustical link.

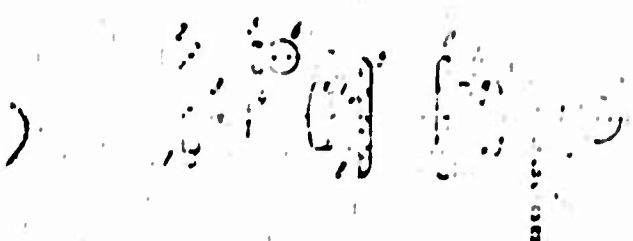

Fig. 21. Optical diagram of transparency-meter: 1 - lamp; 2 - mirror; 3, 7, 12, 14 - lens; 4, 8, 11, 13 - diaphragms; 5 - heat-reflecting glass; 6 - reference photoelectric cell; 9, 10 -

Fig. 20. External view of FPR photoelectric transparency-meter. 15 - measuring photoelectric cell; 16 - filters.

Neuymin also developed a transparency-meter in which the light pathlength in the water - or, as they say, the test base - can be varied. This meter employs the principle of the multiple reflection of the light beam from a system of three spherical mirrors of identical radius and curvature.

Along with vertical transmittance sounding, another interesting technique involves the recording of light transparency from a moving vessel. One of the first versions of this device was developed by I. Joseph in 1946. This instrument was towed aft of the vessel on a metal line and was connected to the laboratory by a cable. A shortcoming of this kind of test method lay in the fact that the device had a tendency to "roam" and not remain at the assigned depth.

Another towed transmittance-meter, rigidly connected to the vessel by means of a special bar, was developed by K. Polevitskiy. In 1952 Joseph used a shaft in the hold of the vessel "Gauss" for continuous transparency measurements. In this shaft he placed

the simplest kind of meter. Sea water was received uninterruptedly into the shaft through an opening in the bottom of the ship. Using this arrangement, Joseph was able to conduct extensive studies in the Atlantic and North Sea.

Towed sounding transmittance-meters provide a means of studying water transparency under natural conditions. Instruments of the second category afford a picture of the transmittance situation only at isolated points, but with this equipment readings can be taken from bathometric samples obtained from virtually any depth. Another advantage of laboratory instruments is their greater simplicity and operational reliability, inasmuch as the performance of all the instrument's components can be constantly monitored.

For sea water transparency determinations, Japanese specialists have developed an objective photometer and transmittance-meter of special design which employs a test vessel of only 15 cm in length. The light source here is a filament lamp, with a photomultiplier functioning as the receiver. Transmittance is computed from the photocurrent ratios as the light passes through a water sample and air.

The US scientist V. Bart, in his investigations, used a quartz spectrophotometer with a special 50-cm-long vessel. In this device, the water was compared against a standard (twice-distilled water).

All the aforementioned instruments, especially the Japanese transparency-meter, have a short test base, excluding the possibility of high-accuracy measurements in waters of high transmittance.

In recent years Soviet researchers have been using the standard SGN-57 instrument. Figure 22 shows the optical diagram of the SGN-57 used as a transparency-meter. A narrow beam of light from lamp 1 passes through a layer of water which has poured into

vessel 2, and, once it has been reflected from spherical mirror 3, returns to ocular 4. The observer, by equalizing the brightness of the photometric fields of the test and comparison branches of the instrument, records a definite reading on a special gradual drum. Since the SGN-57 has been precalibrated, this reading can be used to determine the transmittance value.

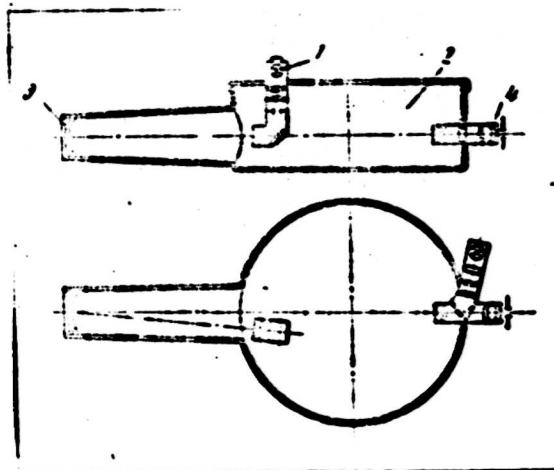

Fig. 22. Diagram of the SGN-57 employed as a transmittance-meter: 1 - illuminator; 2 - vessel with water; 3 - mirror; 4 - ocular.

Sea water transmittance (transparency) is a major optical characteristic. The equipment and methods for its measurement are being constantly improved.

Marine Optics in the Service of Oceanology

Calm. The untroubled glistening of the ocean surface. Not the slightest sign of agitation. But beneath the quiet glassy surface there takes place an invisible but grandiose movement and shifting of the watery layers. Although rarely if ever does a

storm wave on the surface exceed 10 meters in height, the top-to-bottom extent of these internal waves may be calculated in literally hundreds of meters.

The existence of these subsurface fluctuations was determined when measurements were made of the temperature and salinity at the same spot and at the same depths. At that time it was learned that the values of these factors display a definite sequence and periodicity in their variation. Internal wave patterns stand out with particular boldness in readings of the occurrence depth of discontinuity (jump) layers - that is, those layers in which there is a sharp variation in temperature and density along the vertical.

A knowledge of the occurrence depth of these discontinuity layers is extremely important. It has been observed that it is precisely in the neighborhood of these layers that significant fish catches can usually be had. For submarines, the discontinuity layer is that "liquid ground" on which the boat can be rested.

Under the effect of the internal waves the depth of the discontinuity layer may vary significantly. One hypothesis holds that the loss of the US atomic submarine "Thresher" occurred precisely for this reason. It is not impossible that, having come to rest on the "liquid ground," for a short period the boat was at considerably greater depths, thus leading to its destruction.

The position of the jump layer can be easily and rapidly determined using a photoelectric transparency-meter. Naturally, this instrument records not the density difference Translator's Note - Because of a fault in the reproduction of the text, one page of the original is missing at this point.7

The displacement of agitated particles along the southern shores of the Baltic Sea has been studied with the aid of a

photoelectric transparency-meter by the German scientist G. Luneburg. For the same purpose, a similar device, designed in the Southern Branch of the Institute of Oceanology, was installed in the submarine laboratory "Chernomor." Often, these streams of small silt particles are of impressive size. One such flow, stretching some 1200 km, has been identified off the coasts of South America.

Marine optics also plays an extremely effective ancillary role in support of oceanology in so important and complex a question as the identification of waters of different origin. Frequently, such waters differ not only in their fundamental hydrological properties - temperature and salinity - but also in their suspended-particle content and, thus, in their transmittance. Even when the transparency of different waters, carried by powerful ocean currents, is identical, they can still be distinguished through the employment of optical methods.

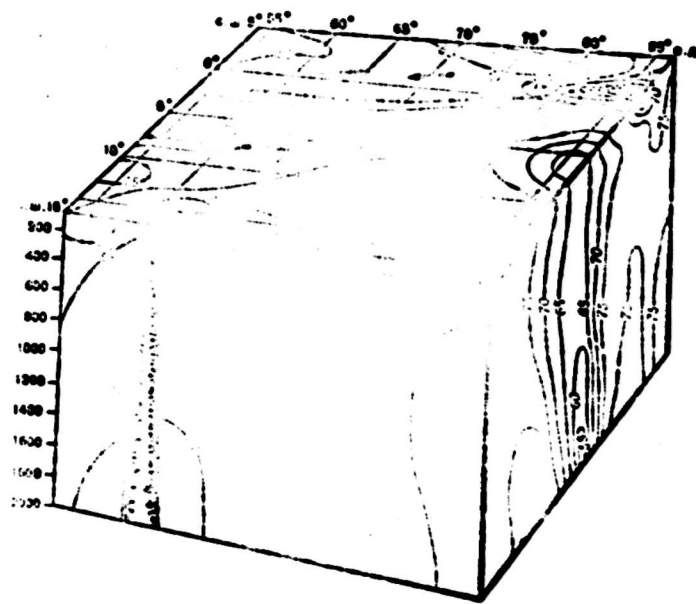

Fig. 23. Block diagram of the transmittance of the waters of the tropical part of the Indian Ocean. The arrows indicate the direction of the main currents; the broken line, the boundaries between the currents.

Figure 23 shows the block diagram of the transparency (transmittance) of the waters of the tropical area of the Indian Ocean, as compiled according to the findings of the scientific instrumentation vessel "Vityaz'." This diagram indicates the current boundaries as hydrologically determined. It will be readily seen that these boundaries coincide with the turbid water zones extending along the currents. The reduced transmittance in the boundary zones is related to the different dynamic processes which have a stimulating effect there on the accumulation of mineral particles and the development of phyto- and zooplankton.

The waters of the open ocean and the landlocked seas differ markedly from one another in their content of "yellow matter," the concentration of which in the sea can be easily determined on the basis of transmittance measurements in the blue or ultraviolet region of the spectrum.

Many other examples might be cited illustrating the usefulness of marine optics in the conduct of oceanological studies.

SUNLIGHT IN THE SEA

Light on the Surface of the Sea

In our study of natural light in the sea we must first of all ask the question: what about the light that illuminates its surface?

Every second, as the result of nuclear reactions in the bowels of the Sun, 564 million tons of hydrogen are transformed into 560 million tons of helium; 4 million tons of solar hydrogen are radiated into space in the form of heat and light. The energy power of solar radiation is estimated at $3.86 \cdot 10^{23}$ kW. If the Sun's energy is expressed in calories per second and the entire energy it emits in a year is summed, we arrive at a figure of some $3 \cdot 10^{33}$ cal. Naturally, of this total amount our planet receives an infinitesimal fraction - only some one two-billionths, i.e., 10^{24} cal - but even this is an enormous amount of energy.

The principal characteristic of the Sun's radiative capacity is customarily considered to be the **solar constant** - that is, the power of solar radiation per one square centimeter of a surface perpendicular to the incident rays and situated outside the terrestrial atmosphere. More or less accurate direct measurements of the magnitude of the solar constant have been possible only since the advent of the space age. According to present-day data, this figure is $2.00 \text{ cal/min} \cdot \text{cm}^2$ or 1394 W/m^2 .

As it passes through the Earth's atmosphere, the energy of direct solar radiation is attenuated, due to partial absorption and partial scattering. The energy reaching the surface of the sea is not constant, depending as it does on numerous factors. The lower the position of the Sun above the horizon, the greater the thickness of the atmosphere its rays must traverse and the greater, consequently, the absorption and scattering losses. Taking as a unit the path traveled by the ray in the atmosphere when the Sun is at the zenith (this is known in meteorology as the "atmospheric mass"), one can obtain from the following figures a clear notion of the degree to which this path grows longer as the Sun sinks lower:

Height of Sun, degrees.....	90	60	45	30	10	5	1
Atmospheric mass...	1.0	1.15	1.4	2.0	5.4	10.4	27

Thus, when the Sun has just emerged over the horizon its rays must overcome an atmosphere which is 27 times thicker than when it is at its zenith.

The second basic factor affecting the weakening of the solar radiation flux is the transparency of the atmosphere at a specific site at a specific moment of time. The greater the number of dust particles, water droplets, and ice crystals contained in the atmosphere, the less this atmosphere will be transparent and the greater will be the solar energy losses within it.

Despite these losses, however, the sea's surface receives an enormous amount of energy. Thus, it is reasonable to consider (albeit with some approximation) that in the summer season, with the Sun high in the sky, one square meter of the sea's surface is exposed to the effect of light radiation having a power of about one kilowatt. Unquestionably, this figure varies very

widely depending on the geographic latitude of the location and the season of the year. These variations are graphically illustrated in Fig. 24.

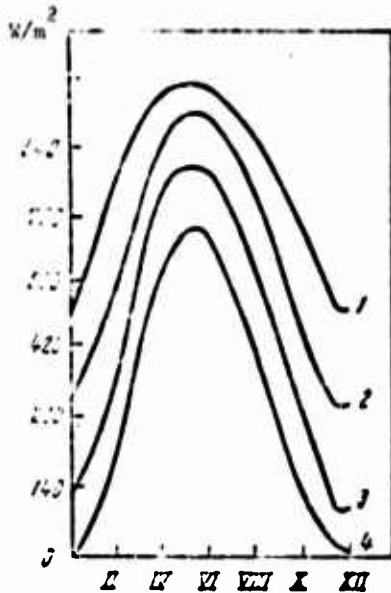

Fig. 24. Relation of sea surface irradiation to geographical latitude and season of the year (latitude: 1 - 35°; 2 - 45°; 3 - 55°; 4 - 65°).

In this way, we have briefly considered, from the standpoint of its energy content, the direct solar radiation reaching the surface of the sea. Of equal interest to marine optics is the spectral composition of this solar emission, since it is this aspect that is basically responsible for those optical processes with which we are concerned in our study of light in the sea.

The shallow surface layer of the Sun, measuring only some 100-200 km in thickness (and known as the photosphere), emits into space an extremely wide band of energy wavelengths ranging from 100 nm to 30,000 nm. Fortunately for all life on Earth, our atmosphere introduces significant corrective factors into this solar radiation spectrum. Thus, the ozone layer which girds the globe at an altitude of 40-50 km absorbs the entire ultraviolet radiation of the Sun on wavelengths of less than 290 nm. Were this not so, the Earth would be a dead planet for the reason that

ultraviolet radiation on the shorter wavelengths is lethal to living organisms. A significant portion of the infrared emission is likewise absorbed by the atmosphere. For these reasons, the spectral composition of the energy that we can measure at the surface of the sea differs markedly from the composition as emitted by the Sun. Just as the total energy quantity reaching the sea's surface, so also its spectrum depends on the height of the Sun and on the state of transparency (transmittance) of the atmosphere. The energy distribution in the solar spectrum for an absolutely pure atmosphere containing no moisture (that is, under ideal conditions) is shown in Fig. 25. As the height of the Sun decreases there is a change in the spectral composition of its radiation: the maximum gradually shifts toward the longer-wave region of the spectrum, with the emission intensity continuing to diminish.

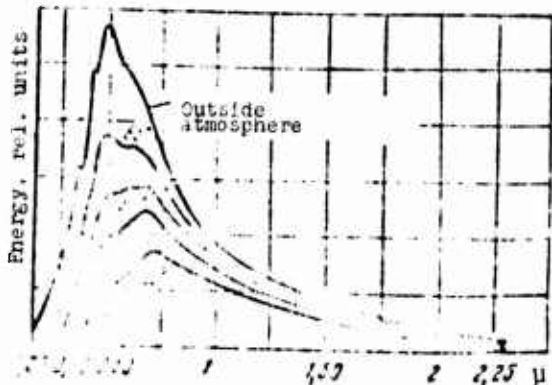

Fig. 25. Energy distribution in solar radiation spectrum for different heights of the Sun and for ideal atmospheric conditions.

Of special interest to marine optics are those changes which occur, with changing height of the Sun, in the visible region of the spectrum - that is, in the waveband from 400 to 760 nm. How does the portion of visible radiation vary in the spectrum? The answer to this question can be seen in Table 1, where data are presented for the ultraviolet, visible, and infrared regions of the spectrum in percentages of total radiation.

Table 1.

Radiation, nm	Height of the Sun above the horizon, degrees					
	5	10	20	30	50	90
Ultraviolet (295 - 400)	0,4	1,0	2,0	2,7	3,2	4,7
Visible (400 - 760)	33,6	41,0	42,7	43,7	43,9	45,3
Infrared (>760)	61,0	58,0	55,3	51,6	52,9	50,0

Careful examination of this table will reveal one noteworthy effect. Beginning at the 20° position of the Sun there is only a minor change in the ratio of visible and infrared radiation, while the ultraviolet radiation undergoes a better than two-fold increase.

The sea's surface is illuminated not only by the direct rays of the Sun, but also by light incoming from the sky - that is, by solar rays which have been scattered by the atmosphere. This scattered radiation exhibits a spectral composition which is different from the Sun's direct radiation and which, at the same time, is extremely changeable depending on the nature and number of the clouds which happen to be obscuring the sky. For a graphic appreciation of the diversity of the spectral composition of the light illuminating the sea surface consider Fig. 26, which shows just how markedly the spectra of direct and scattered solar radiation do in fact differ. To facilitate comparison of the curves, a value of 100 units has arbitrarily been assigned to radiation having a wavelength of 560 nm.

Fig. 26. Spectral composition of sum (1), scattered (2), and direct (3) solar radiation.

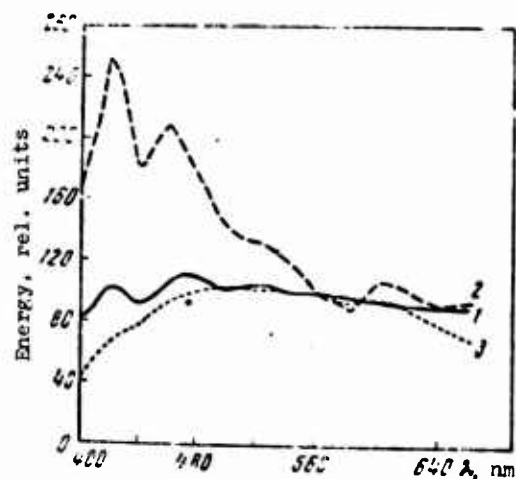

The contribution of scattered light to the total radiation striking the surface of the sea is not constant and depends on the height of the Sun.

Height of Sun, degrees.....	5	10	20	30	40	50
Scattered radiation, %.....	73.4	42.9	29.0	21.0	18.0	15.4

The contribution is extremely great when the Sun is low above the horizon.

With what light, then, are we ultimately dealing when we speak of the illumination of the sea surface? No one simple answer can be given to this question - too many factors affect both the absolute value of the incident energy as well as its spectral composition: the height of the Sun, the transparency of the atmosphere, the character of the cloud cover, and others. The best approach is to consider the sum radiation, that is, the combination of direct and scattered radiation.

The energy distribution in the sum radiation spectrum is illustrated by curve 3 (see Fig. 26). Naturally, the sum radiation is subject to the same changes which are also proper to its constituent parts. The inconstancy in the character of the light illuminating the surface of the sea has been well described in the book Prozrachnost' I Tsvet Morya /The Transparency And Color Of The Sea: "So-called daylight, which represents the point of departure for all possible kinds of hydrooptical calculations, is itself an ill-defined concept by virtue of the variability of its intensity, spectral composition, and brightness distribution across the celestial sphere¹."

¹Vs. A. Berezkin, A. A. Gershun, and Yu. D. Yanishevskiy. Prozrachnost' I Tsvet Morya.

If in addition one considers that the conditions of the sea's illumination change not merely during the day, but also depend both on the geographic latitude of the site and the season of the year, the full complexity involved in determining this "point of departure" will become readily understandable. Thus it is that when conducting most hydrooptical studies, along with measurements of the light in the sea it is simultaneously necessary to carry out direct observations of the radiation incident to its surface.

Propagation of Sunlight Within the Sea

A clear sunny afternoon. The sea is still, virtually without motion, its surface like a mirror. Of course, the quality of this mirror leaves much to be desired, for when the Sun is at its zenith the surface of the sea reflects very little light - no more than 2% of the incident light flow, with the remaining 98% penetrating into the water. As the height of the Sun decreases, that is, as the angle of incidence of its rays increases (Fig. 27), the portion of reflected light increases, approaching 100% when the Sun nears the horizon (Fig. 28).

As they pass through the sea's surface and enter the water, the Sun's rays are refracted - that is, they change their direction. Even the early Greeks were at a loss to find the relationship between the angles of incidence and refraction. A table has been preserved listing precise measurements of the angles of refraction and incidence of light in water as compiled as long ago as 140 B. C. by the celebrated Greek astronomer Claudius Ptolomaeus; however, it was only in 1621 that the Dutch mathematician Willbrord Snell (Snellius) successfully formulated the law relating the angle of refraction of a ray with its angle of incidence: "The relation of the sine of the angle of incidence to the sine of the angle of refraction for two given media is a constant value."

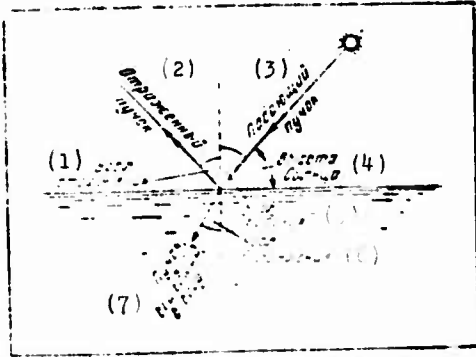

Fig. 27. Passage of light through the surface of the sea.
KEY: (1) Angle of reflection; (2) Reflected beam; (3) Incident beam; (4) Height of Sun; (5) angle of incidence; (6) Angle of refraction; (7) Beam having entered water.

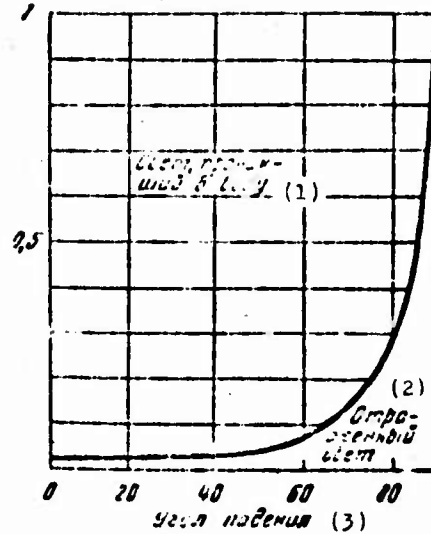

Fig. 28. Dependence of coefficient of reflection on the angle of incidence of the rays.
KEY: (1) Light which has penetrated into the water; (2) Reflected light; (3) Angle of incidence.

Mathematically this can be written in the form of a formula:
$$\frac{\sin \alpha}{\sin \gamma} = n;$$
 α here is the angle of incidence of the rays; γ is the angle of refraction (see Fig. 27). The constant for two given media is known as the **refraction constant**.

The angle of refraction of the rays can be directly expressed through their angle of incidence: $\sin \gamma = \frac{1}{n} \cdot \sin \alpha$. Since the refractive index of sea water with respect to air is approximately 1.34, then in our case $\sin \gamma \approx 0.746 \sin \alpha$.

The greatest possible angle of incidence for the rays is 90° (meaning that the rays are sliding along the very surface). The sine of 90° equals one, the sine of the angle of refraction is 0.746, corresponding to an angle of approximately 48° . This means that however great the angle of incidence of the rays to the

smooth surface of the sea, the angle of refraction cannot exceed 48° . In turn this means that any ray entering the water deviates from the vertical by no more than 48° . There are no direct solar rays of other directions in water.

Conversely, only those rays can exit from the water into the air which propagate in the water at an angle of no more than 48° from the vertical, while all other rays will be completely reflected from the surface back into the water (this phenomenon is called **total internal reflection**).

On a quiet sunny day attempt to lie on your back under water and look up. Overhead you will see a large circle of light; this circle is formed by the light which has passed through the surface. With respect to the rays striking from the side, they have all experienced total internal reflection from the water's surface, and outside the circle of light you will see only the reflected image of the faintly illuminated bottom (Fig. 29).

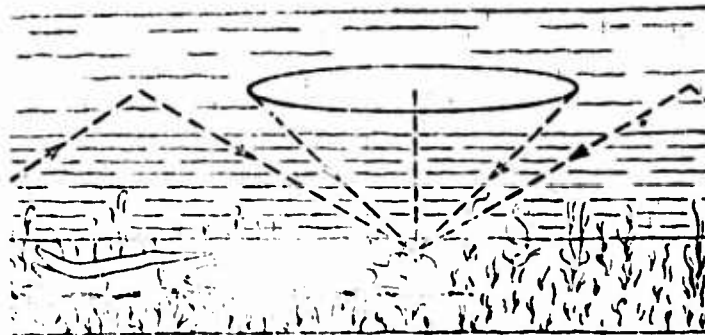

Fig. 29. What we see from under water.

Sea disturbance (agitation) complicates considerably the pattern described above. When the sea is affected by waves, the solar rays encounter the curved sea surface at different angles at different points. Accordingly, the light's coefficient of reflection (reflectance) by the sea surface at different points will also be different, depending as it does (see Fig. 28) on the angle of incidence of the rays.

If the Sun is high above the horizon, the mean angle of incidence of the rays on the disturbed sea surface is greater than in calm weather. There is an increase in the total amount of light reflected by the surface and, correspondingly, a decrease in the amount of light entering the water. With the Sun at from 55 to 90° the sea-surface transmission factor of the light decreases from 97-98% for still weather to 94% for a disturbance rated at more than one point. Conversely, with the Sun low the wave crests begin to noticeably shadow the horizontal segments of the surface; the light is reflected from the steep sections of the crest surfaces for which the incidence angle of the solar rays is small. The result is a considerable increase in the transmittance of light by the sea surface: with the Sun at 10° the transmission factor increases from 72% for calm weather to 83% for waves. With the Sun at close to 25° surface disturbance has virtually no effect: light transmittance for still and windy weather stands at approximately 90%.

Investigators measuring the illumination right beneath the sea's surface with the aid of underwater photometers have been impressed by a mysterious phenomenon: on windy days illumination is 15-30% less than the value recorded from measurements of the reflected light flux. In a dead calm this effect is not observed. Where does the solar energy disappear to?

Several hypotheses have been advanced. One of these held that there exists directly beneath the surface of the sea a relatively nontransparent layer of water from a few centimeters to 1-2 meters in thickness. Highly turbid and filled with air bubbles, this layer was considered responsible for the inexplicable loss of solar energy. This view was greeted with almost universal scepticism and has been refuted by later research.

The proper explanation for the enigmatic "surface loss effect" was provided by A. A. Gershun. In Fig. 30 it will be seen that agitation redistributes the illumination on the horizontal surface. The minor ripples act on the incident light rays like cylindrical collecting and scattering lenses. They focus the solar rays in small volumes, while in other regions creating perceptible rarefactions of the light. According to theoretical computations, the wave-focused light waves at depths of 6-9 m are capable of giving rise to an illumination 8 times greater than the mean value for the level in question. But since the bunching regions of the light occupy far less volumetric space than the regions of lowered illumination, an underwater photometer will record a less-than-average illuminance reading. The sea surface is dynamic, and from time to time the indicator arrow deflects sharply toward the higher illumination intensity readings, whenever the focus of the "wave lenses" passes through the underwater site of the photoelectric cell.

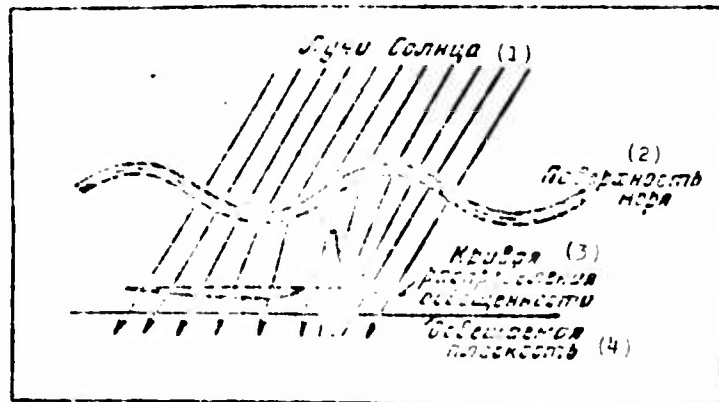

Fig. 30. Explanation of the "surface loss effect."
 KEY: (1) Solar rays; (2) Sea surface; (3) Illuminance distribution curve; (4) Illuminated surface.

There is reason to believe that the intermittent and nonuniform nature of the illumination in the subsurface layers of the sea has an effect on the photosynthesis process and on primary production.

Sunlight Attenuation with Depth

The further fate of the light, once it has struck the water, is determined by two physical processes - absorption and scattering. As a rule, scattering in sea water is considerably more intense than absorption and, as a consequence, light in the sea is scattered repeatedly. Each photon has several opportunities to alter the direction of its movement before it is absorbed by the medium.

As the depth increases, the amount of direct sunlight decreases in comparison with the scattered light, which gradually becomes predominant. Moreover, the sea is always being struck by light which has been scattered by the atmosphere. This light too, as it propagates ever more deeply, is also subject to absorption and scattering.

Since the sea water scattering indicatrix is greatly elongated in the direction of the incident beam, during the scattering process by far the greater part of the sunlight photons experience a minor change in the direction of their movement and continue to travel deeper into the sea. Only a small portion of the scattered light is upwardly directed, creating in the sea an ascendent beam of light.

We have already spoken of how beams of light, once they have entered the water, deviate from the vertical by no more than 48° . If there were no scattering in the sea, then, diving into a deep spot (where bottom reflection might be disregarded), we should see light only in these directions, while from the bottom and sides we would be surrounded by impenetrable murkiness.

Because of multiple scattering the entire sea is literally permeated by light - any point under water is traversed by a countless multitude of light beams moving in every conceivable

direction. "As soon as our eyes were under water," relates Thor Heyerdahl, "the source of light, unlike our surface world, ceased as it were to exist. The refracted rays reached us not only from above, but from below; the sun no longer shone, it was everywhere... Here below the light was remarkable for its amazing clarity, and its effect on us, accustomed as we were on the deck to the tropical sun, was very calming. Even when we looked down, into the bottomless abyss of the ocean into the realm of eternal black night, this night seemed to us to be tinted a pleasant blue as it reflected the rays of the sun.¹"

To gain a better understanding of how radiation is distributed in different directions, let us mentally decompose, at some point beneath the surface, the descending and ascending light flux into "elementary" beams of light. From the point in question, in the direction of each beam, we draw a segment proportional to its brightness. Then, connecting the ends of the segments, we obtain a closed surface. The volumetric body bound by this surface is known as a brightness body.

The form of the brightness body gives an idea of the structure of the light field at the given point. For example, a parallel beam of light has a brightness body in the form of a rectilinear segment in the direction of this beam, while radiation uniformly scattered in all directions presents a brightness body in the shape of a sphere.

Under the joint action of scattering and absorption the form of the brightness body in the sea changes with depth (Fig. 31).

Direct sunlight predominates near the surface. The brightness body is sharply extended in the direction of the Sun's rays,

¹T. Heyerdahl. Voyage on the Kon Tiki, M., "Molodaya gvardiya," 1956 (in Russian).

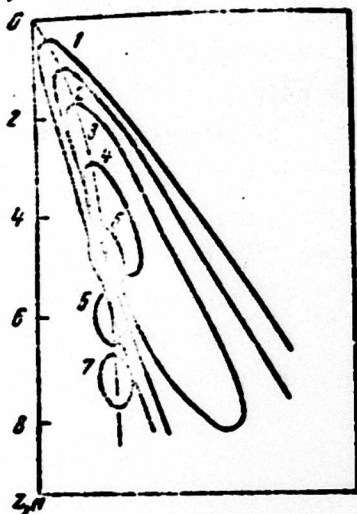

Fig. 31. Variation in the form of the brightness body with depth:
 1 - 4 m; 2 - 10 m; 3 - 17 m;
 4 - 29 m; 5 - 41 m; 6 - 54 m;
 7 - 66 m.

particularly if the sky is cloudless. Because of scattering, the elongation of the brightness body diminishes with depth, the body growing shorter and rounder. In addition, there is also a change in the direction of the preeminent propagation of the radiation: beams diverging considerably from the vertical travel a longer path through the water and are, consequently, more severely attenuated with depth. In this way, the axis of the brightness body gradually rotates with increasing depth until it coincides with the vertical (Fig. 31).

At rather great depths the brightness body takes on a permanent form. This steady-state radiation distribution at a depth is referred to as the **depth condition**. It is important to note that the form of the brightness body in the depth condition depends on the optical properties of the sea water at the point in question, with conditions of external illumination and the state of the sea's surface playing no role. For example, in a totally scattering medium (no absorption), regardless of external illumination, the depth body of brightness is sphere-shaped, while in a totally

absorbing medium (no scattering) it is represented by a rectilinear segment. In intermediate instances the brightness body in the depth condition is a body of rotation with respect to the vertical axis, whose elongation depends on the ratio between scattering and absorption, as well as on the form of the scattering indicatrix.

The existence of the depth condition was predicted by Academician V. A. Ambartsumyan. This interesting phenomenon was subsequently substantiated experimentally, first in simulated media and later directly in the sea. At the Marine Hydrophysics Institute detailed studies of the conditions accompanying the onset of the depth condition were conducted by V. A. Timofeyeva, who also established the relationship between the form of the angular brightness distribution and the scattering-to-absorption ratio. Timofeyeva used milk and rosin media, absorption in which was measured by the addition of a dye in different concentrations. The depth at which a brightness body of constant form is established is a function of the ratio between scattering and absorption and also of the scattering indicatrix. In a highly absorbent medium the depth condition ensues only after the original light flux has been substantially attenuated. From this standpoint, the sea represents an ideal testing ground for the study of the depth effect, since, as a rule, scattering in sea water far exceeds absorption. Institute of Oceanology measurements have shown that in the Black Sea a brightness body of constant form occurs at a depth of only a little more than 100 m. In the more transparent Mediterranean this condition materializes only at the 200-meter mark.

The onset of the depth condition depends largely on how the surface of the sea is illuminated. In the case of a cloudy sky, when there are no direct solar rays, the depth of its occurrence is significantly less than in the presence of directional solar radiation.

Spectral Composition of Sunlight at Different Depths

We already know how the attenuation of a directional beam of light in a light-scattering medium takes place, how Bouguer's law is formulated, and what the light attenuation factor is. If we examine the behavior not of some isolated beam, but of the entire flow propagating from the surface down into the sea, we shall see that, as a first approximation, the attenuation of this flow (flux) as a function of depth is also governed by an exponential law: $\phi_z = \phi_0 \cdot 10^{-\alpha z}$ (ϕ_0 is the value of the light flux directly beneath the sea's surface; ϕ_z is the value of the flux attaining a depth z). The exponent α in the formula is known as the **vertical attenuation index** and should not be confused with the attenuation index ϵ . These two indices differ considerably in magnitude. The attenuation index ϵ is used to estimate the attenuation of a beam of light traveling in some one direction and is composed of the absorption and the entire scattering. The vertical attenuation index α characterizes the attenuation of the entire descending light flow in the sea (that is, the flow as made up of a multitude of "elementary" light beams of different directionality). This factor is composed of the absorption and only a small fraction of the scattering (for, as we have already observed, the greater portion of the scattered light continues to propagate deeper into the sea). It is clear, therefore, that the vertical attenuation index α will always be substantially smaller than the attenuation index ϵ . For example, in the Black Sea, when the attenuation index ϵ stood at 0.17 m^{-1} , the vertical attenuation index α was found to equal only 0.04 m^{-1} .

So sizable a discrepancy is of enormous importance to light propagation in the sea. In effect, attenuating with an index of 0.04 m^{-1} , the descending flux is 10,000 times weaker at a depth

of 100 m, while had it attenuated at an index value of 0.17 m^{-1} , it would have decreased at the same depth by 100,000,000,000,000,000 times - that is, for all practical purposes it would have been undetectable.

The value of the vertical attenuation constant α is affected by the character of sea-surface illumination (in the upper layers it depends on the height of the Sun) and the depth. Here, the inhomogeneity of the optical properties of the sea water along the vertical and the depth-related variations of the radiation composition also play a role. Following the onset of the depth condition, the α index no longer changes and its value is a function only of the optical properties of the medium.

The wavelength of the light is a determining factor in the vertical attenuation index α . Different regions of the solar spectrum attenuate differently in water, and the spectral composition of the light varies according to depth. It is a familiar fact that the spectral dependences of the absorption and scattering of light in water differ for different waters. A consequence of this is that the vertical attenuation index α also depends on the wavelength of the light in a different fashion. These differences are at the heart of the sea-water classification system worked out by N. Jerlov.

Ocean waters are divided into three basic types, with two additional intermediate types found between types I and II (IA and IB). Coastal waters show a greater variety in the characteristics: based on the results of his measurements along the coasts of Scandinavia and the American northwest, Jerlov has subdivided these waters into nine types. Figures 32 and 33 show how the descending light flux decreases with depth in different waters, in addition to presenting spectral transmission curves for these waters. Figure 34 illustrates the spectral distribution of sunlight at different depths in the cleanest ocean waters.

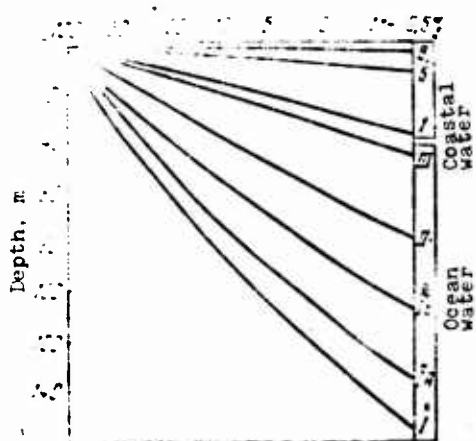

Fig. 32. Attenuation of the descending light flux with depth in waters of different type (% of light incident to the surface).

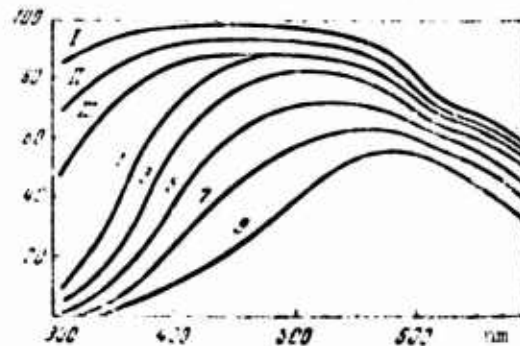

Fig. 33. Spectral transmission curves (% per 1 m) of the descending light flux for waters of different type.

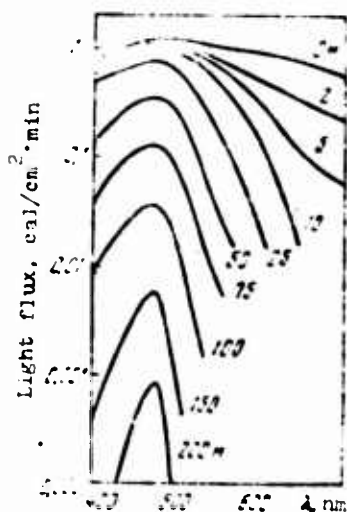

Fig. 34. Spectral distribution of light at different depths in the purest ocean waters.

A common property of all sea-water types is severe depth-related attenuation of the red portion of the spectrum. The disappearance of the red component from the light flux propagating into the sea may lead to unexpected underwater effects. One such effect has been reported by Cousteau and Dumas. They were treated to an astonishing picture when at a depth of thirty or forty meters Dumas (Didi) harpooned a large liche fish.

"...The blood was green! Stunned by this spectacle, I swam closer, my eyes fixed on the stream gushing from the heart of the now dying fish. It was emerald in color. We looked at each other in puzzlement. As many times as we had swum among this species, never had we suspected that their blood was green. Taking firm hold of the harpoon with its amazing trophy, Didi swam up. At a depth of fifty-five feet the blood became brown; at twenty feet it had managed to turn pink, and on the surface it was flowing in crimson streams¹."

In order to understand the reasons for this interesting phenomenon, one must be clear as to what in fact determines the visible light of any object. A brief answer to this question is not simple - a number of factors affect the perception of color by the human eye. Chief among these factors is the spectral composition of the light reflected by the object. Every surface reflects differently the light of different spectral regions. For example, if the color of an object is red, this means that this object reflects red rays better than the others. An object's color also depends on the kind of light by which it is illuminated. If a red object is placed in a beam of light in which there is virtually no red, that object will no longer seem red (which is another way of saying that if there is no red in the incident beam, there will be none in the reflected beam).

When the depths of the sea are illuminated in brilliant white light, the true colors of this underwater world can be seen. This is how the authors of The Silent World describe this riot of color:

"At one-hundred-and-fifty meters Didi trained his reflector on the side of a reef and switched on the light. The reef literally exploded in color! The beam of white light disclosed a blinding spectrum in which deep reds and oranges predominated. The

¹J.-Y. Cousteau, F. Dumas. Ibidem.

brilliance of the colors was reminiscent of the paintings of Matisse. For the first time since the creation of the world the entire magnificence of this twilight zone came alive in rich blazing light. We were beholding a spectacle never before seen - even the fish had never witnessed anything of the sort. Why had such a wealth of color been gathered together here where there was no one to treasure it? And why at these great depths was there a predominance of that same red which was the first color to be filtered out in the upper layers? What colors lurked still deeper below, in the realm of never-ending gloom?"

Is There a Limiting Depth to the Penetration of Sunlight?

Many investigators have frequently asked the question: at what depth in the sea does the sunlight disappear altogether? Two centuries ago this problem was posed in general form by Pierre Bouguer: "Knowing by experience the diminution suffered by light as it passes through a known mass of transparent body, determine the thickness which must be imparted to the body in order to make it nontransparent.¹"

Bouguer believed that the Sun becomes totally invisible if its light is attenuated 900 billion times.

We can easily find this depth in the sea by assigning the appropriate value to the vertical attenuation index α . In transparent waters, for the blue-green portion of the spectrum, the optimum value of α equals approximately 0.02 m^{-1} . By substituting this value of α in the formula $\phi_z/\phi_0 = 10^{-\alpha z}$, we have

¹P. Bouguer. Ibidem.

no difficulty in finding the depth at which there will be a 10^{12} -fold attenuation in the sunlight: $z = 12/0.02 = 600$ m. In more turbid waters this depth will naturally be far less.

The American biologist Beebe, in a bathysphere descent to a depth of almost one kilometer, was an eye-witness to the advent of this "realm of eternal night." "At a depth of 750 meters the darkness had seemed unimaginably black, but now (at about 1000 meters) it was blacker than black. I had the impression that all future nights in the upper world would seem like only relative degrees of twilight. And I was never again able to use the word 'black' with any real conviction."¹

But for all this, today's light receivers - photoelectron multipliers - are capable of recording the presence of sunlight even at these depths. The most highly sensitive of these receivers have the ability to detect even individual photons! Analysis shows that if on a clear and sunny day a receiver of this kind is lowered to a depth of 1000 m, in transparent waters (with a vertical attenuation index $\alpha = 0.02 \text{ m}^{-1}$) it will record the incidence of about one photon per second.

However, the sunlight penetrates to even greater depths. The 1200-meter mark is attained by only one photon of every 10^{24} striking the surface of the sea - at this point our receiver would record the occurrence of a single photon approximately once every twenty-four hours... and at 1500 m, once in 300 years!

The probability of a photon of sunlight reaching the bottom of the Mariana Trench - the deepest spot in the ocean - is so small that such an event might not even take place once in the entire history of mankind.

¹V. Bib /Beebe/. Na glubine kilometra /One Kilometer Down/. M.-L., Detgiz, 1937 (in Russian).

Polarization of Light in the Sea

From the point of view of classical physics, light represents electromagnetic waves. An electrical field, varying in time and created by some sort of radiating element, causes the appearance of an alternating magnetic field, with the direction of vibration of this magnetic field perpendicular to the direction of the electrical vibrations. Variation of the magnetic field in turn generates a variable (alternating) electrical field which re-excites an alternating magnetic field, and so on and so forth.

The originated electromagnetic field does not remain fixed in space, but propagates at the colossal speed of $300,000 \text{ km/s}^1$ along a line perpendicular to the directions of the electrical and magnetic oscillations. The human eye is capable of perceiving electromagnetic waves whose length range from 380 to 760 nm. However, the term "light" is frequently taken to mean not only the visible radiation, but also the shorter wavelengths - the ultra-violet (wavelength from 10 nm) - and the longer - the infrared (wavelength to 340 micrometers).

Consider the origin of the electric field vibrations. We have already mentioned that they run perpendicular to the propagation direction of the light wave; however, in the plane perpendicular to this direction these vibrations may be oriented in virtually any manner (Fig. 35, 1). In so-called natural light, of the kind emitted, for example, by the Sun, the electrical vibrations are found along all the possible directions lying in this plane. In the path of this kind of light let us place a plane-parallel disk cut from a crystal whose properties differ for different

¹The figure of $300,000 \text{ km/s}$ is the speed of light in a vacuum; in water it is approximately $225,000 \text{ km/s}$.

directions (such a crystal is said to be anisotropic). Through this crystal will pass only those light waves whose electrical field vibrations run parallel to the axis of the crystal.

Light in which the electrical oscillations occur in only a single direction is referred to as linearly (or plane) polarized light (Fig. 35, 2). A good idea of this kind of light can be had by watching the vibrations of a long rubber band. If the free end of an attached rubber band is quickly raised or lowered, a wave will travel along the band, while each point of the band will vibrate in a strictly vertical fashion in a plane perpendicular to the direction of propagation of the wave. What we are looking at is a vertically polarized wave. Just about the same thing also takes place in a light wave, only here we are dealing not with the mechanical vibrations of rubber band particles, but with

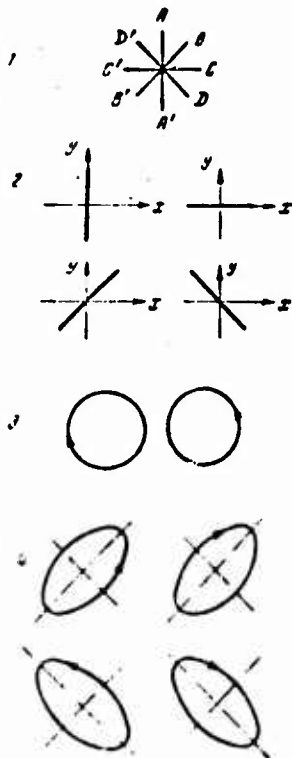

Fig. 35. Electrical field vibrations in the plane perpendicular to the direction of propagation of a light wave: 1 - natural light; 2 - different instances of linearly polarized light; 3 - circular polarization; 4 - different instances of elliptical polarization.

the periodic variations of an electrical field. If the end of the band is moved not vertically (up and down), but horizontally (from right to left), the band will be traversed by a horizontally polarized wave. Other, more complicated types of polarization are also possible: for example, circular or elliptical (Fig. 35, 3 and 4). For these types, the end of the band must be quickly rotated in a circle or ellipse.

Special optical devices exist which make it possible to achieve polarized light of any of the aforementioned types. These instruments are called **polarizers**.

Rarely is the polarization of light total; normally light is polarized only partially - that is, it represents a mix of natural and polarized light. The completeness of polarization is characterized by the degree of polarization, this being the ratio of the totally polarized component intensity to the sum intensity of the beam. The degree of polarization is normally expressed in percentages: 0% refers to natural light, 100% to fully polarized light.

One should not get the impression that polarized light comes about only artificially. Quite the contrary, polarization of light is an extremely common phenomenon in nature, occurring both in reflection, refraction, and during the process of scattering.

As early as 1809 the French astronomer Dominique Arago discovered that sunlight scattered by the atmosphere is polarized. During the 160 years which have elapsed since this discovery scientists in the field of optics have been very successful in investigating the polarization of light in the atmosphere, with the result that at the present time this effect has been studied in great detail.

The first measurements of daylight polarization under water were conducted in 1954, although the study of the polarization of light in connection with reflection from the surface of the sea had been begun some twenty years earlier. Today, this effect is exploited for practical purposes at sea: polarizers mounted in observation instruments cut off the light reflected by the sea surface which interferes with the tracking of underwater objects.

The maximum depth at which underwater polarization has been measured is 200 m. It has been established that scattered light under water is linearly polarized and is characterized by a fairly high degree of polarization - as much as 60%. The degree of polarization decreases with depth, this reduction occurring at a particularly fast rate in the immediate subsurface layer (20-30 m). At great depths the degree of polarization remains virtually unchanged.

The special interest displayed in the polarization of light in the sea is linked to a certain unusual phenomenon. The polarization of light has been found to affect the behavior of aquatic organisms and in many instances to influence significantly the laws of their locomotion.

The capacity for orientation according to the position of the polarization plane of linearly polarized light was first discovered, in the honey bee, in 1948. The Austrian biologist Karl Frisch called attention to the fact that the scout-bee, indicating the direction to the honey flow by his "weaving dance," can properly orient his dance only when at least a part of the blue sky is visible. On the other hand, sky light is always polarized. Frisch, therefore, advanced the hypothesis that it is this polarized sky light which acts as a kind of compass for the bee,

permitting it to orient itself properly in space. To this end, he conducted a series of experiments which thoroughly confirmed the correctness of this view. Later, the ability to react to the polarization of light was discovered in many other arthropods: beetles, butterflies, ants, and spiders.

The human eye also possesses the property of being able to discern linearly polarized light with a different vibrational direction; however, while in man this is merely a curious and even little-known feature of vision, for the invertebrates this ability in many instances plays a major functional role. The fiddler-crab (scud), for example, is capable of proper self-orientation in the water only when he can see above him the Sun or a section of the blue sky. If a polarizer is placed above him and slowly rotated, the crab also will begin to turn accordingly. Many other aquatic animals are also sensitive to the polarization of light: swimming cladocera crabs, water fleas (*Daphnia*), water mites, and the xiphosura.

The mechanism of this interesting phenomenon is not yet thoroughly understood.

How Natural Light is Measured in the Sea

As has already been noted, for many years light measurements in the sea were affected by a fundamental misconception: the desire to find the depth beyond the reach of daylight. Quite naturally, this boundary has not been found to this very day, since as the measuring methods have improved and the sensitivity of the instrumentation used in the radiation recording has increased, light readings have also been obtained at ever greater depths. The whole question actually has to do with the quantities of

light energy involved - whether it be tens of lux (if we are discussing illumination intensity) or individual photons detected by high-sensitivity equipment.

The first efforts at light measurements in the sea, undertaken in the second half of the nineteenth century, involved the use of a photochemical reaction in certain liquids and gas. The point of departure here was Bouguer's well known law to the effect that the yield of a photochemical reaction is proportional to the product of the radiation intensity and the exposure time. This principle was at the heart of the Regnard hydrochloric actinometer, in which the light effect was estimated by the decrease of a gas mixture. In the thirties of the present century, Atkins proposed a photochemical photometer in which the decomposition of uranium oxalate was employed. Although these instruments offered the advantage of relative simplicity in design, they provided illuminance measurements only in the uppermost layers of the sea and on the condition of very extended exposures.

At about the same time, photographic plates began to be used, and somewhat later films as well. Despite the great variety of photometers employing photographic plates, the measurement principle was ultimately the following. A plate, enclosed in a sealed housing with a glass viewing aperture, was lowered into the sea to a specified depth. Then, using a flyweight lowered along a cable, the photometer shutter was opened. After a definite exposure (the duration of which was recorded) a second flyweight closed the shutter. The effect of the light was to darken the plate. By comparing the degree of darkening of this plate with another similar plate, but which had been illuminated by a standard light source, a determination was made (with allowance for the exposure time) of the illumination intensity conditions at the measurement depth in question. When film was used in place of plates, a timing mechanism which advanced the film at specified time intervals was incorporated in the instrument.

The processing of the measurement results demanded extraordinary care, but even so the accuracy of the findings obtained was extremely low. With the aid of photometers of this kind, light has been successfully detected at depths of more than 1000 m. The fact is, however, that this requires a plate exposure time of more than an hour. One test has been reported in which a plate was exposed for two hours at a depth of 1700 m, with no signs of darkening detected.

In the early twentieth century scientists began to base their measurements on the physical phenomenon known as the **photoelectric effect** - that is, the ability of certain substances to generate an electric current or to vary the value of such a current under the effect of light.

Beams of light, falling on the surface of a metal plate (such as alkali metals as potassium and cesium are used for this purpose), transfer their energy to the electrons present within the metal. The acquired energy increases the speed of their motion and the electrons are able to overcome the forces confining them inside the metal and to exit beyond its surface, giving rise in this way to photoelectron emission from the surface of the plate (photocathode). This is an elementary description of a photoelectric cell with **external photoeffect**. The operation of photoelectron multipliers is based on the external photoeffect phenomenon.

If instead of a metal plate a glass plate is employed and is coated with a light-sensitive layer of some semiconductor substance (such as selenium, thallium sulfide, bismuth sulfide, etc.), with the resultant device connected to an external circuit and the plate illuminated, it will be possible to observe what is known as the **internal photoeffect**. Under the action of the light there is a reduction in the internal resistance of the semiconductor. Such devices are referred to as photoresistors.

In hydrophotometry, the most widely used are photocells with a photoeffect in the blocking layer. These devices are also manufactured from semiconductors - selenium, germanium, silicon, etc.. Their primary advantage is the possibility of obtaining a considerable photocurrent through illumination of the active surface with no external source of electromotive force.

Through the use of radiation receivers whose operation is based on the photoeffect phenomenon (photocells) it has been possible to conduct extensive illuminance measurements in different areas of the World Ocean.

The operating principle of virtually all present-day underwater photometers is based on a law discovered by Stoletov to the effect that the value of the current generated by a photocell is directly proportional to the light flux incident to the cell. Therefore, by taking photocurrent readings at different depths we are able to determine the illuminance at the level with which we are concerned. Naturally, every hydrophotometer is calibrated in advance on a photometric test bench where each reading of the recording device is associated with a specific illumination intensity value.

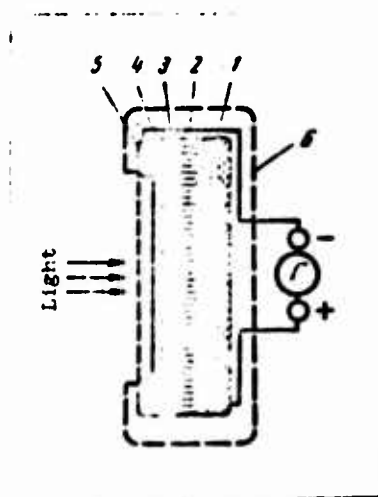

Fig. 36. Diagram of selenium photocell device: 1 - iron plate; 2 - selenium layer; 3 - blocking layer; 4 - gold or platinum film; 5 - contact ring; 6 - plastic housing.

The most commonly employed sensor in hydrophotometers is the blocking-layer selenium photocell. A device of this kind is shown schematically in Fig. 36. Iron plate 1 is coated with a layer of selenium 2, onto which is atomized a very fine (thousandths of a micron) gold or platinum semitransparent film 4. In the processing of the photocell a thin blocking layer 3 is formed on the surface of the selenium. Contact ring 5 is laid on the semitransparent gold film; the iron plate functions as the second electrode. The entire cell is enclosed in an insulating plastic housing 6.

In addition to simplicity of design, the selenium photocell offers one further significant advantage - its spectral sensitivity approximates that of the human eye. Of all the photoelectric cells known at the present time, the selenium cell can be most easily corrected by means of filters to bring its sensitivity into accord with the visibility curve of the eye (Fig. 37).

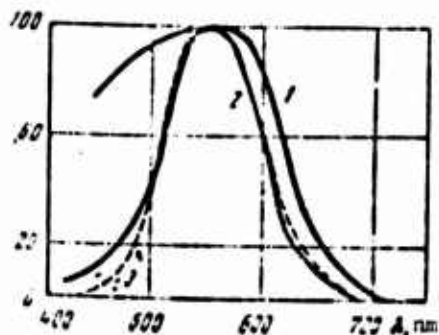

Fig. 37. Spectral characteristics of selenium photocell without correction (1), with correcting filter (2), and spectral sensitivity of the eye (3).

For measurements in the sea, the cell is placed in a sealed housing, the viewing port in which is made of a thick mat glass (opal glass) and is convex in form. This last feature is necessary in order that there be collected on the photocell surface all the light scattered in the upper hemisphere (or in the lower if the port is directed downward), and not merely those rays which strike the radiation receiver on the perpendicular.

An external view of one of the first industrially produced underwater illuminance-meters (the FMPO-57) can be seen in Fig. 38. The instrument has the form of a chandelier in which four portholes are directed upward and one downward. In three of the five sensor housings filters are located ahead of the selenium photocell: a red, a blue, and a green. In this way, it is possible to measure not only the total light flux, but also to discriminate its spectral components. In order that the readings will provide a determination of the radiation traveling from the depths of the sea toward its surface, the fifth cell is accommodated in a housing whose port is aimed downward.

Fig. 38. External view of the FMPO-57 underwater illuminance-meter.

On a cable secured to an oceanological winch the FMPO-57 is lowered into the sea to a depth of 100-150 m. The photocurrent generated by the selenium under the effect of the light is transmitted by wire to the ship where it is recorded by a microammeter.

For all its structural simplicity, this instrument suffered from a multitude of defects. The fact is that illumination intensity in the sea varies very widely: from tens of thousands of lux on the surface to mere units at a depth of some 100 m. Selenium photoelements, on the other hand, perform poorly in the face of high light levels since under such conditions their photocurrent ceases to be directly proportional to the intensity of

the light. In other words, the FMPO-57 began to perform with acceptable accuracy only when submerged to depths of several tens of meters, where illuminance did not exceed 100-200 lux. Moreover, the three-color light filters were clearly too few for studies of the ability of sea water to transmit light of different wavelengths.

A group of designers at the Zagorsk Optical-Mechanical Plant (under the direction of N. F. Shipuli and V. I. Ryabinin), along with A. K. Karelin, an engineer from the Hydrooptics Laboratory of the Institute of Oceanology, developed the FMPO-60 - an instrument which, although somewhat more structurally sophisticated, represented a more advanced sea illuminance-meter - and a number of its subsequent modifications (the FMPO-64 and the LYuPO).



Fig. 39. FMPO-64 equipment set.

The FMPO-64 (Fig. 39) is sphere-shaped with three windows directed upward, downward, and at a 90° angle to the vertical. Located inside the sealed sphere is a selenium photocell which, by means of a small electric motor, can be position in front of each of the three ports. In addition, the sphere also accomodates two disks with a set of colored and neutral filters which (also by means of a motor) are positioned as required

between a port and the photocell. This arrangement makes it possible, as the instrument is lowered into the sea, to vary the density of the light attenuators (neutral filters), thus guarding the selenium against high exposure levels. This device carries not three, as before, but six colored filters which uniformly divide the entire visible range of the spectrum into comparatively narrow segments. All control functions are handled remotely from a console located on board the vessel and connected to the instrument by cable.

The FMPO-60 offers one more advantage. Its complete package contains not only an underwater illuminance-meter, but also an analog sensor for measurement of the light striking the sea's surface. This surface sensor is set up in an area of the deck free from shade or somewhere in the ship's superstructure, and provides a recording of all the changes occurring in the illumination of the sea surface during the measurements.

In such clean waters as those encountered in the open reaches of the ocean or in the Mediterranean the FMPO-60 can record light to depths of 200-250 m. Normally, for light readings at greater depths the sensitivity of the photocells is not adequate, and they are replaced by photoelectron multipliers (PEM). In purely practical terms, the optical circuitries of PEM illumination-intensity meters differ little from photocell devices. They also incorporate sets of neutral and colored filters.

The solution to many problems of marine optics requires the ability to measure not only the light traveling into the sea or directed toward its surface, but also the total intensity of the radiation reaching a given point from all directions. To this end, there is provided for instruments of the FMPO-60 type a special adapter manufactured of opal organic glass in the shape of a sphere. This unit is secured to the side port of the instru-

ment. A spherical radiation receiver of this type detects light arriving from all sides and directs it to the photoelectric cell. Specifically, measurements taken with the adapter enable the specialist to determine the sea-water absorption index.

In addition to the instruments described above, there exist a large variety of underwater illuminance-meters, although, as a rule, they differ only in the number of filters used, the mechanisms whereby these filters are switched, or other design features of secondary importance.

Along with the positive features of photoelectric radiation receivers, these devices share one very serious shortcoming - they are all selective, that is, they react differently to radiation of different wavelength. When studying light in the sea, there is frequently a need for measurements of the sum radiant energy at different depths. For these purposes, however, the most convenient approach is through the use of nonselective radiation receivers whose operational principle is based on the thermoelectric effect - that is, the origination of an electromotive force because of the different degree of heating of the black and white surfaces of a thermocouple¹.

Batteries assembled from a specified number of thermocouples are called **pyrometers**. The most commonly used in marine optical investigations is the Yanishevskiy-system pyranometer. In this instrument the receiver is a surface composed of a system of series-connected manganese-constantin thermocouple strips. This surface offers the appearance of a checker board of black and white cells, since part of the junctions (the hot) have the color

¹Many different types of thermal light receivers are available, such as bolometers, molecular radiometers, and so forth, but to date these devices have yet to be extensively employed in practical hydrooptical research.

of carbon black, while the other part (the cold) are colored magnesium-white.

When operating in the sea, the pyranometer is enclosed in a sealed encasement with a glass window. A galvanometer connected to the circuit records the current generated by the thermobatteries absorbing the radiant energy. The chief defect of the underwater pyranometer is its low sensitivity, which prevents its use even in very clear waters below 50-60 m.

From subsequent chapters in this book it will be clear that it is essential for marine biologists engaged in the study of photosynthesis processes in the sea to know the value of the sum energy to depths of at least 100-150 m. This has led to the need to develop an instrument which, while offering the advantages of the underwater pyranometer (nonselectivity), would also offer far greater sensitivity.

Such a device has now been designed by V. P. Rvachev and his colleagues at the Department of Optics of Chernovitsk State University. According to its principle of operation it has been called a variospectrometric underwater irradiance-meter or, in abbreviated form, the VARIPO.

The optical diagram of this instrument may be seen in Fig. 40. The light strikes opal plexiglass port 1 and, through slot 2, lens system 3. From here, in the form of a parallel beam, the light passes through direct-vision prism 4 (so-called Amici prism). This prism decomposes the light into a spectrum which is projected by objective 5 onto normalizing diaphragm 6 and subsequently, through lens 7, strikes photoelectron multiplier 8.

The secret of the device consists in the normalizing diaphragm. Its function is to "correct" the spectral composition of the light,

bringing it into a kind of accordance with the spectral sensitivity of the photoelectron multiplier - the radiation receiver in the VARIPO instrument.

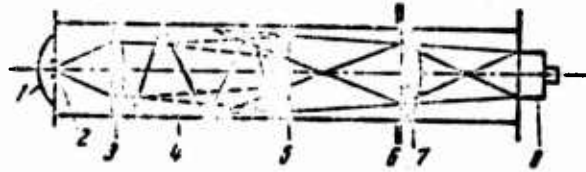

Fig. 40. Optical diagram of the variospectrometric underwater irradiance-meter (VARIPO): 1 - port; 2 - receiving slot; 3 - lens system; 4 - Amici prism; 5 - objective; 6 - normalizing diaphragm; 7 - lens, 8 - photoelectron multiplier (PEM).

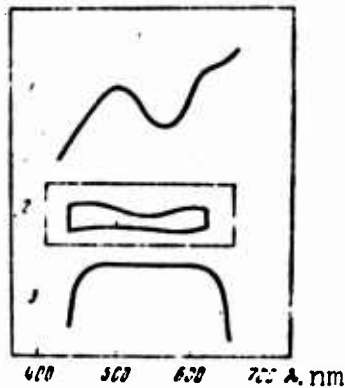

Fig. 41. Spectral sensitivity of PEM prior to correction (1), by shaped diaphragm (2) and its appearance following correction (3).

From Fig. 41, 1 it is evident that the PEM photocathode responds differently to radiation of different wavelength - that is, it is selective. If on the path between the PEM and the spectrally decomposed light we place a shaped filter (diaphragm), cut as indicated in Fig. 41, 2, the sensitivity of the photoelectronic multiplier will be "corrected" and will assume the form of curve 3. In other words, the shaped normalizing diaphragm holds back a part

of the rays to which the PEM is "excessively" sensitive, the result being a nonselective receiver in a specified portion of the spectrum, and one which, in addition, is wholly insensitive to radiation outside that segment.

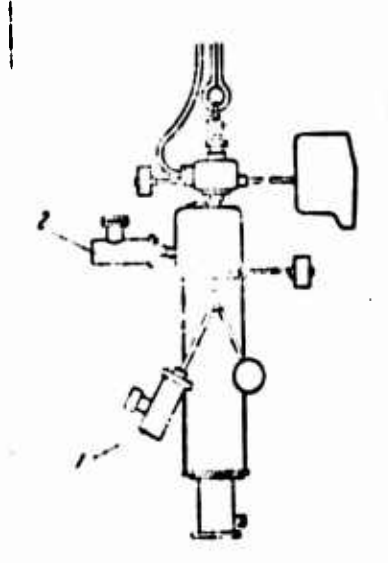

Fig. 42. Instrument for measuring the angular distribution of natural radiation in the sea.

The VARIPO is designed to react to light in the 380-to-700-nm range. This is the so-called region of photosynthetically active radiation. The VARIPO is far more sensitive than the underwater pyranometer, and, despite the high light energy losses with passage through the complex optical system, it can be used to conduct measurements at depths of 100-150 m.

Although they provide interesting information on the variation of light as a function of depth, illuminance measurements by no means cover everything we must know regarding the propagation of radiation in the sea. The most complete information can be obtained by brightness body measurements, that is, measurements of the angular distribution of radiation intensity in different directions. Measurements of this kind were carried out by the American scientist G. Tyler in a lake. A nitometer (brightness meter) was submerged

to a depth of 66 m and spatially oriented by means of a gyroscopic mechanism. The radiation receiver viewing angle was about 7° .

Normally, the angular distribution of radiation intensity is measured in only two perpendicular planes. An external view of this kind of instrument is shown in Fig. 42; it has been used successfully by the Japanese hydrooptical specialist, Prof. Sasaki. The diagram shows two radiation receivers, one of which rotates in the vertical (1) and the other in the horizontal (2) plane. A special feature of this meter consists in the fact that its receivers are PEMS equipped with a special optical system to permit the restriction of the receiver viewing angle to only 4° . By recording the radiation at several points in the vertical and horizontal planes at different depths, diagrams can be plotted for the angular distribution of the light.

These measurements, which are extremely time-consuming, require sophisticated equipment and for this reason have thus far been experimental in nature. In the Soviet Union such readings have been performed by M. N. Kaygorodov, G. G. Neuymin, and A. K. Karelin.

WHY DIFFERENT SEAS HAVE DIFFERENT COLORS

What Determines the Color of the Sea

"Flying around the globe," relates Soviet astronaut German Titov, "I was able to see with my own eyes that there is more water than dry land on the surface of our planet. There was a magnificent spectacle to be beheld as the long bands of waves in the Atlantic and Pacific oceans rushed toward distant shores..."

"Just as the continents, the oceans and seas differ in their color. A palette as rich as that of the Russian seascape artist Ivan Aivazovskiy - from the dark-blue indigo of the Indian Ocean to the salad green of the Caribbean and the Gulf of Mexico."¹

From ancient times the color of the sea has caught man's imagination. Poets have sung of the changeable coloring of the sea's surface and scientists have sought the reasons to explain it. In our own age the transparency and color of the sea have ceased to be merely themes of poetic exclamations or scientific curiosity. In the twentieth century these factors have taken on serious military

¹G. Titov. 700 000 kilometrov v kosmose /Seven Hundred Thousand Kilometers in Space/, M., "Pravda," 1961.

importance. As early as 1939 the English journal United Services Review wrote: "All the major powers use for their submarines a paint designed to provide concealment from the enemy's air forces or, in any event, to impede their effectiveness. Our own submarines are painted different colors depending on the seas to which they are operationally assigned. We use grayish-green colors for the Atlantic, blue for the Mediterranean, black for the Red Sea and certain other waters. In their home waters French submarines are either light-gray or blue-green, while Dutch submarines use dark-green for their home waters and black for those based in the East Indies. Almost all submarines of the Japanese navy are painted black."

In the next chapter we shall be discussing in detail the factors which determine the visibility of underwater objects, but at this point let us attempt an explanation of the visible color of the sea and why different seas are of different color.

That this is so would actually not appear to be surprising, for we are aware that the waters of the seas and oceans differ in their optical properties. In fact, by filling with test water a meter-long tube having transparent ends, one can distinguish even visually, by transillumination, the water, say, of the Indian Ocean with its azure tint from the greenish-colored water of the North Sea. The dark-brown coloration of swamp water cannot possibly be confused with the yellow-green hue of the Baltic.

Anyone, however, who has seen the sea even once cannot have helped but notice that within as brief a period as a single day its waters repeatedly change their color. A light breeze blows, the surface becomes rippled - and immediately there is a change in coloration, with the prevailing hue becoming far more deep and intense; should the sky be obscured with leaden gray clouds, the sea too takes on a gray and forbidding color. Even at the same moment and at the same spot the color of the sea may seem different,

depending on whether one is looking straight ahead and down (over the railing of a sloop, for example) or gazing out further, toward the horizon line.

What then actually is this light which strikes the eye of a person contemplating the sea? On what does its spectral composition depend?

It is easy to imagine that this beam of light primarily contains light reflected from the surface of the sea. It is in fact this light which is responsible for the inconstant color of the sea surface and for its variability as a function of the weather. The coefficient of reflection of the sea surface is virtually independent of the wavelength of the incident light. The spectral composition of the reflected radiation does not differ from the spectral composition of the incident: in clear cloudless weather the surface of the sea reflects the blue of the sky, but when that sky is covered by clouds the sea, like a mirror, reflects their somber leaden gray.

Is this light, however, the only factor which determines the color of the sea? Obviously it is not. For, if this were true, then all seas would have the same color and we should not be able to speak of the "azure waters" of the Mediterranean or of the waters of the Yellow Sea, whose color fully justifies that name. Scientists have determined that every sea has its own peculiar color, although in many seas and oceans these colors are very similar. The "specific" color of a sea is linked to the light flux emerging from within it.

It has already been mentioned that, thanks to the processes of multiple scattering, underwater light travels in all possible directions, including upward, toward the surface. By submerging a photometer the surface of whose sensitive element is aimed down-

ward, we can use this instrument to determine the magnitude of the ascending stream of light. Such measurements are constantly being conducted during optical ocean research both by Soviet and foreign specialists. It has been established that the ascendant flux in the sea increases with depth according to the exponential law:

$\phi_B(z) = \phi_0 \cdot 10^{-\alpha_B z}$ - that is, in the same way as the flux propagating into the sea¹. The index α_B , which is called the index of vertical attenuation for the ascendant light flux, differs only little in value from the descendant flux index, which we have already designated simply as α . Although, strictly speaking, these indices coincide only for the depth condition (abyssal condition), in actual practice they are very close in value at lower depths as well. For this reason, on a chart the depth vs attenuation curves for both the descendant and ascendant flux almost always run parallel (Fig. 43). On the other hand, the absolute values of these streams are not identical: at all depths the ascendant flux is almost two orders of magnitude smaller than the flux traveling down into the sea.

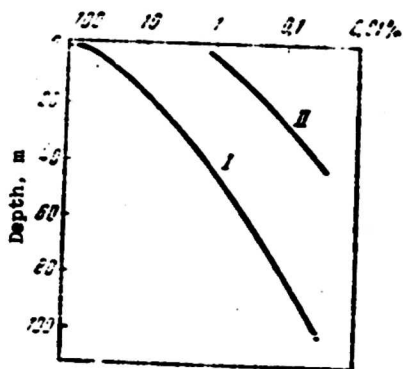

Fig. 43. Attenuation with depth of descendant (1) and ascendant (2) light streams in the Pacific Ocean (% of light incident to the surface).

¹Translator's Note - The subscript letter "B" here and elsewhere is the first Cyrillic letter in the Russian word for "ascendant."

The sea returns only a negligible portion (no more than a few percent) of the radiation received in its lower depths. On a given level, the amount of returned energy can be quantitatively estimated using the diffuse reflection factor ζ , which is equal to the ratio of the ascendant light flux value at the depth in question ϕ_B to the descendant value ϕ :

$$\zeta = \frac{\phi_B}{\phi}$$

Like all the other hydrooptical characteristics, this factor is a spectral quantity, that is, its values depend on the wavelength of the light. The reason for this is to be found in the fact that the spectral compositions of the ascendant and descendant flux streams at the same depth differ. Compare the two diagrams: on one (Fig. 34) there are shown the spectral distributions, for different depths, of downward-traveling light; on the other (Fig. 44) the same distributions are shown for the ascending flux. Both diagrams refer to pure ocean water. It will be readily noted that at all depths the spectral composition of the ascending flux is far poorer in yellows and reds than the descending. We shall discuss the physical causes for this phenomenon below, but for the moment let us direct particular attention to the spectral distribution of the radiation directly beneath the surface - at the zero-meter level. This distribution depicts the color of the light flux exiting from the sea, for the reason that the surface itself has virtually no effect on the spectral composition of the radiation passing through it.

Fig. 44. The spectral distribution, at different depths, of light moving upward toward the surface of the sea.

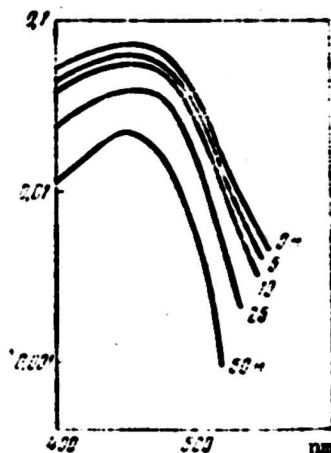

The maximum value of this spectral distribution corresponds to wavelengths of about 450 nm - that is, there is a predominance of blue in the light flux leaving the sea. There is some 10 times less green, while as far as the yellow and red are concerned, these colors are practically absent. In turbid waters the spectral distribution is different, with the maximum shifted toward the green, and in very turbid waters, even toward the yellow region of the spectrum. Using the spectral curves corresponding to the different seas, not only the quantitative, but also the qualitative differences between their colors can be determined, which is of no small importance in the selection of concealment paints for underwater objects.

Thus far the discussion has dealt with the spectrum of the entire light flux leaving the sea. However, as we have already noted, the sea color also depends on the angle at which the surface is viewed. The angular distribution of brightness in the ascendant flux is characterized by the brightness indicatrix.

This curve can be plotted as follows. At a given point on the surface of the sea a measurement is made of the brightness of the exiting radiation in different directions, that is, at different angles to the vertical. The angle of observation θ is read from the downward-directed vertical axis. An angle of 180° corresponds to strictly vertical observation (to the nadir), while angles of 90° and 270° refer to rays skipping along the surface of the sea. The resultant brightness values $\rho(\theta)$ are normally divided by the brightness value for 180° - $\rho(180^\circ)$, that is, the ordinate of the 180° angle equals one.

Three indicatrices for the blue ($\lambda = 465$ nm), green ($\lambda = 517$ nm), and yellow ($\lambda = 591$ nm), as measured by Soviet hydrooptical specialists in the tropical waters of the Pacific, are shown in Fig. 45. The form of the curve will be seen to depend on the

wavelength. For all three indicatrices, the greater the deviation from the vertical, the greater the brightness, but this increase is more marked for the yellow than for the blue. This is to say that if the observation is at a great angle to the vertical, the blue becomes less intense and is more and more diluted by green and yellow - the deepness, or "richness," of the color diminishes.

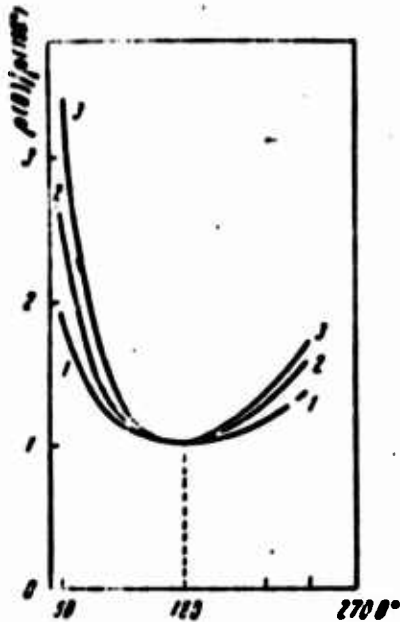

Fig. 45. Brightness indicatrices of the light flux leaving the sea in tropical waters of the Pacific Ocean (1 - $\lambda = 465$ nm; 2 - $\lambda = 517$ nm; 3 - $\lambda = 591$ nm).

As the angle of observation increases, so also is there an increase in the amount of light reflected from the sea surface (the reflection factor is known to vary as a function of the angle: for an angle of 180° it is minimal; for angles of 90° and 270° it equals one). The coloration of the reflected flux is white. Merging with the flux emerging from the sea, the reflected light decreases even further the intensity (richness) of the sea color when observed at large angles - at a distance the surface appears whitish in color.

"The smaller the view angle¹, the greater the importance assumed by scattered sky light in the coloring of the sea," wrote N. N. Zubov. "Therefore, in calm weather, the closer to the horizon, the paler the coloring of the sea. But as the view angle increases, that is, nearer the observer, the natural scattered light begins to predominate and the sea coloration becomes more intense. With the sea disturbed, the light ray strikes the surface at fairly large angles even at considerable distances from the viewer, and therefore the agitated sea always seems more richly colored. Obviously, the higher the waves, the more intense the color..."

"... During a dead calm, particularly if the Sun is obscured by clouds, the sea takes on a whitish hue and the horizon appears blurred. Certain seas, it might be said, lose the individuality of their coloration during calms, but it only takes the slightest breeze to blow and the slightest ripple to furrow the surface for this picture to change utterly. The color of the sea deepens and the horizon takes on a clear and distinct definition."²

Before turning to the physical causes responsible for the "natural" color of the sea, let us recapitulate a few points. The light striking the eye of the observer contemplating the surface of the sea is made up of two light streams (fluxes): in the first place, the light of the Sun, sky, and clouds specularly reflected by the sea surface; in the second place, the light which has emerged from the sea depths. The portion of the reflected light in the total flux depends primarily on the surface reflection factor and varies according to the degree of disturbance of the sea and the view (observation) angle. The sea's natural or "proper"

¹By the view angle, Zubov understands the angle between the direction of observation and the surface of the sea.

²N. N. Zubov. Ibidem.

color is determined by the spectral composition of the light flux emerging from within it; this composition depends on the kind of light illuminating the surface and on the optical properties of the sea water. It is the dissimilarity in these properties in different waters that explains the diversity to be found in the color of the seas.

Light "Returned" by the Sea

In 1903, during a study of the waters of the lakes of Bavaria, the German researcher Aufsess reached the conclusion that all their shadings were due to dye substances mixed in the water. The whole matter was thus reduced to a question of selective absorption. We know, however, that without scattering not a single ray of light would ever emerge from beneath the surface of the sea. The Black Sea, in this case, would completely live up to its name, and indeed the surface of the other seas and oceans (discounting the reflected light) would appear as absolutely black.

Thus, is scattering the principal factor? This view was advanced by a number of men of science, foremost among them Rayleigh; however, it too was found to be in error. If there were no absorption, virtually all the light entering the sea would ultimately reemerge from its surface, with the consequence that the coloration of the emerging flux would coincide with the color of the incident light. Any discussion of the sea's "natural" color would be superfluous.

The truth lay midway between these opinions. In 1922, Ch. Raman and V. V. Shuleykin, simultaneously and independently of one another, arrived at the conclusion that the color of the sea is caused by the joint action of absorption and scattering.

The sunlight traveling into the sea is scattered en route by the sea water. The greater part of the light continues to move

deeper into the sea, but a small portion is scattered back to form the ascending light flux. Raman, who had studied the transparent waters of the Bay of Bengal, considered the scattering only of the water itself, while ignoring the scattering occasioned by the particles suspended in the water. Thus, the formula he derived is applicable only to pure ocean water.

The Shuleykin theory, which subsumes Raman's formula as a particular case, is more general. This theory takes into account the light streams which have reached the surface from different levels, as well as making allowance for secondarily scattered light (that is, that portion of the ascending flux which, moving toward the surface, was first thrown back to a deeper level in the sea and then, as the result of secondary scattering, has again begun to travel toward the surface), along with the light of all the higher multiples of scattering. The formula was derived on the assumption that the sea is illuminated by a stream of parallel rays incident vertically to its surface.

In 1923 A. G. Gamburtsev derived a stricter and more general sea color formula. He wrote a system of two differential equations for the descending and ascending light streams, the solution of which makes it possible to find the spectral distribution of these fluxes at any depth, including on the surface. By substituting in Gamburtsev's formulas the appropriate values of the optical characteristics of the sea water (absorption and scattering indices, scattering indicatrices), one can obtain the spectral distribution curve of the radiation leaving the sea for any point in the World Ocean.

Gamburtsev's formulas are fairly complex, and for that reason we shall not cite them. Instead, we shall consider only the qualitative pattern of the phenomena responsible for color differences in seas and oceans.

Sea water, it will be recalled, is the scene of two kinds of scattering: molecular and particulate. The molecular scattering indicatrix is symmetrical with respect to the plane perpendicular

to the direction of the incident ray - precisely as much light is scattered backward as is scattered forward. In scattering by particles, the amount of forward-scattered light is nearly 50 times greater than the back-scattered light flux.

The intensity of molecular scattering is inversely proportional to the wavelength raised to the fourth power (blue light, for example, with a wavelength of 440 nm is scattered 5 times more intensely than red light with a wavelength of 660 nm). Scattering by particles of suspended marine matter is of low selectivity: the intensity of this kind of scattering is virtually independent of the wavelength.

The sea-water scattering indicatrix is likewise severely elongated in the direction of the incident light - the angular distribution of the scattered light is mainly determined by suspended particles. Even in the case of pure ocean water, scattering by the water molecules amounts to only 7% of the total, but at angles greater than 90° it plays a predominant role, accounting for some $2/3$ of the total intensity. For 90° in pure ocean water the intensity of molecular scattering is 70% of the total intensity, and for 135° - as much as 83%. In waters of this kind, back scattering - and thus the ascendant light flux as well - is fundamentally a creation of molecular scattering. Because of the fine selectivity of molecular scattering, the flux coloration is violet-blue.

Moving toward the surface, this light undergoes the filtering effect of the sea water. Maximum transmittance in pure ocean water occurs in the blue-bluish green portion of the spectrum (see Fig. 33). As a result of the joint action of scattering and absorption, the light stream, having left the sea, has a deep blue color in pure ocean water.

In turbid waters containing a large amount of suspended particles the role of molecular scattering is minor even with large scattering angles. At 90° the intensity of molecular scattering comprises only 13% of the total intensity, but at 135° the figure is 25%. In these waters the ascending light flux is primarily

a creation of suspended-particle scattering, which is nonselective. Maximum turbid-water transmittance is displaced toward the yellow-green region of the spectrum. In less transparent waters the result of the combined action of these effects is to impart a gray-green appearance to the sea surface, while in very turbid waters the surface may even take on a yellowish cast.

If blue is the color of the "ocean desert" that is, the waters which are poor in plankton and nutritive substances - then a yellow-green color to the surface is an indication of "fertile ocean soils." Numerous measurements made during research expeditions have provided practical confirmation of the closest possible connection between the sea's color and its transparency. This relationship is illustrated in Fig. 46.

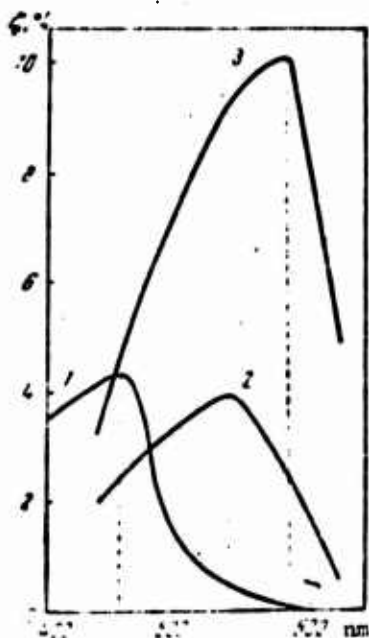

Fig. 46. Spectral distribution of diffuse reflection factor: 1 - open ocean; 2 - Maizuru Bay; 3 - Yura River.

This figure depicts the spectral distributions of the diffuse sea reflection factor ζ for pure ocean waters, the less transparent waters of Maizuru Bay, and the very turbid waters of the Yura River. These curves were plotted according to test data furnished by the Japanese investigator Hishida. It is quite apparent how

the distribution maximum shifts from the blue (for the transparent water) to the yellow (for the turbid). There is a similar change also in the spectral dependence of the sea's brightness factor (Fig. 47). This value is equal to the ratio of the brightness of the radiation $B(\theta, \varphi)$ emerging from within the sea in a direction defined by the angles θ and φ (where θ is the zenith distance and φ is the azimuth) to the brightness B_0 of an ideally scattering un-submerged horizontal surface illuminated by natural light:

$$\rho(\theta, \varphi) = \frac{B(\theta, \varphi)}{B_0}.$$

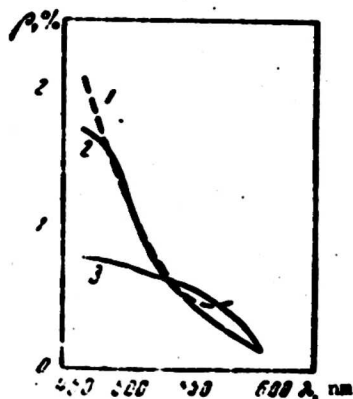

Fig. 47. Spectral dependence of the brightness factor for (1) waters of the Pacific Ocean, (2) the Mediterranean, and (3) the Black Sea.

The spectral dependence of the brightness factor represents most accurately the "intrinsic" light of the sea. This value does not depend on the spectral composition of the radiation incident to the sea's surface and is wholly determined merely by the values of the spectral indices of light absorption and scattering of the sea water.

The sea's brightness factor ρ is very closely related to the sea's diffuse reflection factor ζ beneath the surface. The spectral dependences of both these factors virtually coincide.

We have disregarded one additional factor which may affect the visible light of the sea - reflection from the ocean floor. Although at depths of several hundred meters the influence of this parameter may be disregarded, in more shallow waters the coloring of the bottom has a definite effect on the color of the surface. A bottom covered by a carpet of green seaweed lends a greenish cast to the sea color as well, at the same time that a sprinkling of bright pebbles on the floor has the effect of reducing the overall color saturation of the water. Normally the water in shallow reservoirs is always extremely turbid for the reason that almost any disturbance will cause mud, silt, sand, and other fine particles to rise from the bottom. The coloration of such bodies differs markedly from that of deeper basins. The Sea of Azov, for example, whose depth is nowhere greater than 14 m, gives off a pale grayish-green color.

Measuring the Color of the Sea

"... It is to be noted to what degree the strange or variable color of the sea derives from a change in depth, the color of the sea floor, the sky, or the clouds, the light of the sun, or else from foreign substances present on the surface of the water...¹" - these words are found in the instructions written by O. E. Kotzebue during his voyage around the world. However, although Kotzebue did devise a quantitative criterion for water transparency - the depth of disappearance of a submerged white disk - he was able to determine the color of the sea only qualitatively - by the color of the waves.

¹O. Ye. Kotsebu /Otto von Kotzebue/. Puteshestviye v Yuzhnyy okean i Beringov proliv dlya otyskaniya severo-vostochnogo morskogo prokhoda, predprinyatoye v 1815-1818 gg. na korable "Ryurik" /Voyage to the Southern Ocean and the Bering Straits in Search of a Northeast Sea Passage, Undertaken in 1815-1818 on the Vessel "Ryurik"/. SPb., 1821 (in Russian).

It was only in the nineties of the last century that the Swiss scientist Francois Alfonse Forel proposed the first primitive device for observations of the color of bodies of water. In his investigations of the color of the water of mountain lakes in the Swiss Alps, Forel made use of a set of test tubes filled with a mixture of solutions - blue and yellow - taken in different proportions.

His method was simplicity itself: the observer determines visually what test-tube solution color matches the visible color of the body of water in question. Each tube is numbered. The number of the tube selected by the observer is entered into an observation logbook as a quantitative description of the color. Forel employed 13 tubes, in which the blue and yellow solutions were in the following ratios:

No.....	I	II	III	IV	V	VI	VII	VIII	IX	X	XI	XII	XIII
Blue....	100	98	95	91	86	80	73	65	56	46	35	23	10
Yellow..	0	2	5	9	14	20	27	35	44	54	65	77	90

For the blue solution he used a mixture of copper sulphate and ammonia; for the yellow, a half-percent solution of potassium bichromate.

The German oceanographer Ule specially adapted Forel's scale for sea color measurements. He eliminated tubes XII and XIII, since these colors were not found in the seas, and added 10 new shades. Ule introduced a third kind of solution - one which was brown in color and prepared by adding ammonia to cobalt sulphate in the presence of air. The solution ratios in Ule's tubes appears as follows:

No.....	XII	XIII	XIV	XV	XVI	XVII	XVIII	XIX	XX	XXI
Blue....	35	35	35	35	35	35	35	35	35	35
Yellow..	60	55	50	45	40	35	30	25	20	15
Brown...	5	10	15	20	25	30	35	40	45	50

Accommodated in the wooden mounting frame proposed by Yu. M. Shokal'skiy (Fig. 48), the Forel--Ule scale became one of the standard oceanographic instruments, despite the absence of any single, unified methodology for its use. Some investigators held the scale against the light or against a background of white or black paper, while others observed it on the sea bottom or against the background of a white disk submerged in the water.

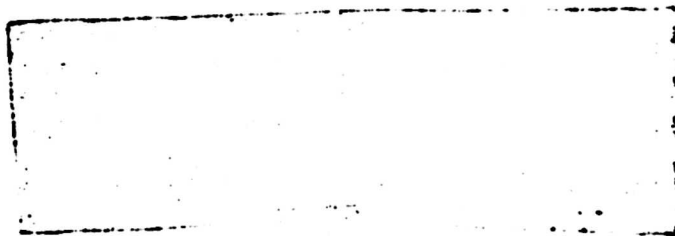

Fig. 48. Color scale.

Obviously the Forel--Ule scale was capable of providing nothing more than a purely qualitative and highly subjective sea-color estimation. The chief, and perhaps the only, positive feature of this instrument was its simplicity and ease of use. Its deficiencies were innumerable. First of all, it did not measure the sea's own "intrinsic" light, which is necessarily of primary concern to oceanologists, but the sum color of the light flux streams reflected by the surface and emerging from within the sea. Secondly, its operation involved a violation of the fundamental requirements of colorimetry (the measurement of color): no provision was made to ensure that the background against which the transparent solutions of the scale were viewed would remain constant. A sharp demarcation or boundary between the fields under comparison (the sea and the solution) is lacking. It is a known fact that an observer is capable of accurately detecting differences in color only when the compared fields are of approximately identical brightness, but the Forel--Ule scale provides no possibility whatever of balancing the compared fields in terms of

brightness. Finally, there is the purely technical, but very substantial, deficiency of the inconstancy of the solutions (the changing and fading of their colors, etc.).

For all these shortcomings, the Forel--Ule scale won extraordinarily wide acceptance in oceanology and oceanography. Extensive testing with this system helped establish, for example, that the color of the waters of the Mediterranean corresponds to that of tube I, the open areas of all oceans to tubes I and II, the Caspian to tubes VII--IX, the sites where rivers empty into the Baltic to tube XII.

It was natural that marine physicists could not be satisfied with a system as imperfect as the Forel--Ule scale, if for no other reason than that the system was clearly inadequate for the determination of the physical laws at issue. Efforts were thus directed at devising a more advanced colorimeter, and these efforts were to prove successful when in 1939 such an instrument was invented by A. A. Gershun. This device, known as a hydrophotometer, permits measurements of the sea's spectral brightness factors ρ , that is, the spectral relations of the brightness of the radiation flux emerging from the sea to the brightness of the incident flux.

The design of this instrument was subsequently further developed and improved. Presently in use is an apparatus of similar type developed by K. V. Maller, the FM-46 hydrophotometer, which offers a number of significant advantages over Gershun's original design.

The structural diagram of the FM-46 is shown in Fig. 49, and its external view in Fig. 50. In addition to the technical improvements (tropicalization and the capability of conducting measurements from high-sided vessels), the instrument provides one extremely useful feature - the ability to measure the brightness

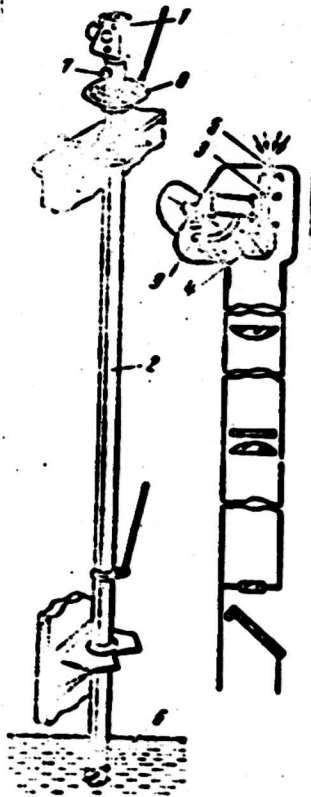

Fig. 49. FM-46 hydrophotometer:
1 - photometric head; 2 - tube;
3 - opal glass; 4 - photometric
prism; 5 - opal glass plate; 6 -
mirror; 7 - mirror rotating
handle; 8 - azimuthal control
wheel; 9 - light filters.

of radiation emerging from within the sea not only strictly along the vertical (at the nadir), but also at different angles to the vertical and at different azimuths with respect to the Sun.

The FM-46 is a visual photometer which effects a comparison of the brightness of two photometric fields. One of these fields is created by the light issuing from within the sea (in a specified selected direction), the other by the natural light of the Sun and sky illuminating the opal glass plate 5 located on the instrument's photometric head 1. The photometric head is equipped with a tube 2 whose lower end is submerged 10-15 cm under water. For observations of the sea mass in a given direction, secured to the

lower end of the tube is sighting mirror 6, which can be inclined by handle 7 (varying the angle to the vertical) and rotated by ring 8 (varying the azimuth). Six colored filters 9, mounted in the instrument, provide measurements of the spectral composition of the emission leaving the sea. The brightness levels of the photometric fields are balanced by shifting opal glass 3 located between photometric prism 4 and receiving glass 5. The tube itself consists of three sections, while its total length (depending on the height of the vessel above the water) may be either 3.5 or 6 m. The complete instrument also includes a special mechanism for attaching it to the side of the ship. Observations are conducted from the side illuminated by the Sun. Virtually calm weather is required for measurements, and readings must be suspended whenever the sea disturbance exceeds two points. When measuring the brightness factors of the sea, attention must be paid to the cloud cover and notice taken of the height of the Sun.

The FM-46 hydrophotometer enables specialists to arrive at a quantitative estimation of the energy distribution in the spectrum of the radiation emerging from the sea, it being precisely this spectral distribution on which, as we have seen, the "intrinsic" light of the sea in fact depends. The curves in Figs. 45 and 47 were obtained with the help of the FM-46. Its advantages over the Forel-Ule scale are obvious: there - a subjective evaluation; here - a physical measurement; there - one single digit, the tube number; here - two functional dependences of the brightness factor ρ : on the wavelength $\rho(\lambda)$ and on the observation angle $\rho(\theta_1)$. The aggregate of these dependences contains all the information on the intrinsic light of the sea, and not only for vertical observation downward, but for all other directions as well.

Some researchers, for their sea color readings, employ the International Colorimetric system, but this method has yet to win any real acceptance in hydrooptics.

Fig. 50. Measuring the color of the sea.

WHY WE SEE WORSE IN WATER THAN IN AIR

The Eye's Ability to See in Water

The well known American hydrooptical specialist S. Q. Dantley has written in one of his works: "Nowhere in nature is the principle of protective coloring and camouflage more in evidence than in the feeding grounds of the sea, where the life of predator and victim alike depends equally on the ability to see. When man enters the underwater world and peers through a glass at his submarine surroundings, his success and his safety depend in large measure on his visual ability¹."

But if that same man were to peer at his underwater environment not through some glass shield, would he be able to see anything under water? The answer is no; he would only be able to distinguish dark from light and to discern the vague and blurred outlines of objects. The same human eye which is capable of seeing stars at distances of hundreds of light years is practically helpless in water. This is because of the conditions of light propagation in the aqueous medium and the physiology of the human eye.

¹S. Q. Dantley. Underwater Visibility. - "The Sea."
N. Y. - London, 1962.

The subject matter of our book is at great remove from the problem area of physiological optics, but an understanding of the incredibly complex physical and physiological processes involved in underwater vision requires that we at least cursorily consider certain properties of the sight organs both of man and of the inhabitants of the sea - the fish.

The eye of an adult human being is an almost spherical body, about 25 mm in diameter (Fig. 51). Externally the eye is covered by a dense albuminous envelope, the sclera. Its front (somewhat curved) portion is transparent. This is the cornea of the eye. The cornea's refractive index is 1.37. Behind the cornea is the forward chamber of the eye, which is filled with a liquid having a refractive index of 1.33. Located beneath the sclera is a vascular membrane, whose forward section forms the iris, with a center opening known as the pupil. Depending on the intensity of the light striking the eye, the pupil in a reflexive response changes its size from 1.5-2 mm under intense illumination to 6-8 mm in darkness. This self-regulatory reaction of the pupil is one of the links in the process referred to as the eye's adaptation to the illumination level.

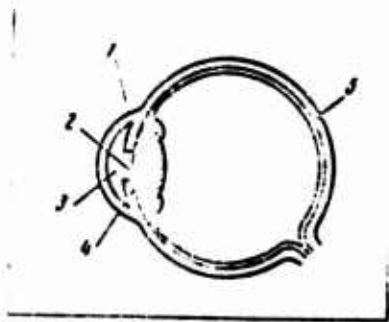

Fig. 51. Sectional view of the human eye: 1 - cornea; 2 - pupil; 3 - forward chamber; 4 - crystalline lens; 5 - retina.

A vital optical element of the eye is its crystalline lens, which separates the eye's forward chamber from the rear chamber; the latter is filled with a transparent glassy substance with a refractive index of 1.34. The crystalline lens of the human eye is pea-shaped in form and functions as a lens, that is, it projects

the image of the object being viewed onto the retina. Thanks to the ability of the crystalline lens to vary the curvature of its surfaces (primarily the forward surface) within specific limits (accommodation), the image on the retina of objects at different distances is always sharp and in focus. Impairment of the eye's accommodational ability results either in nearsightedness or farsightedness. The body of the crystalline lens is nonuniform, and its refractive index ranges from 1.38 to 1.41.

Acting as the receiver of the radiation entering the eye is the light-sensitive retina, which is located on the internal surface of the vascular membrane. Anatomically the retina represents a very complex structure. Within a thickness of about 0.2 mm it contains 10 light-sensitive layers. The light-sensing elements of the retina are the rods and cones, whose visual functions are different. Thus, the rods (approximate length 0.06 mm) possess enormous sensitivity, with the most insignificant amount of light sufficing for their excitation. The cones, while far less sensitive to the stimulation of light, have the capability of distinguishing colors. The cones "work" only when the illumination intensity exceeds 30-40 lux, at which time the rods are inactive; at lower illuminance only the rods are operative. The eye contains a total of some 7 million cones and 130 million rods, with all the cones arranged in the central portion of the retina known as the **yellow spot** (macula lutea), and the rods around its periphery. The result of this division of the visual functions of the rods and cones is that we are able to distinguish the colors of objects only if the lighting is good. As the conditions of illumination deteriorate, the cones are disengaged from the perception process and the function of light-perception passes to the rods, which, as we have seen, are incapable of color-perception. It is for this reason that all objects, regardless of their color, seem gray in twilight.

The light-sensitive element of the rods is the substance rhodopsin. In the dark this substance appears purple in color, but under the action of light it loses its color and breaks down into protein and retinene. The restorative reaction occurs in darkness. The cones contain the substance iodopsin, which decomposes under light and forms in decomposition phosphoric acid. The iodopsin reaction mechanism is not entirely clear even to this day.

As a result of the decomposition of the rhodopsin and iodopsin (photodissociation process), negative ions originate, which act on the nerve fiber endings of the optic nerve, to which are connected the rods and cones. An electric signal reaches the brain and causes the occurrence of a light (visual) sensation.

In our consideration of the structure of the eye, it was no accident that we mentioned the values of the refractive index of its individual parts. The fact is that these values are close to the refractive index of sea water, which happens to equal 1.34; only in the crystalline lens is the figure somewhat larger. The result of this is that if the eye comes into direct contact with water, the light rays pass into it virtually without refraction - that is, they cannot be focused by the crystalline lens on the retina. In a person with normal vision the accommodational capabilities of his eye are not sufficient to so alter the form of the crystalline lens so that it will focus the image precisely on the retina in water. Only very myopic people, for whom in the air the image is focused ahead of the retina, will see more or less normally in water.

For this reason, an indispensable condition for underwater vision is the insulation of the eye from the water by means of the masks used by skin divers or the glass windows found in diving

helmets and bathyscaphes. In this case, there is an intervening layer of air between the eye and the water, with the light rays entering the eye not from the water but from the air. With the transition from the air into the eye the rays are refracted and the eye functions normally.

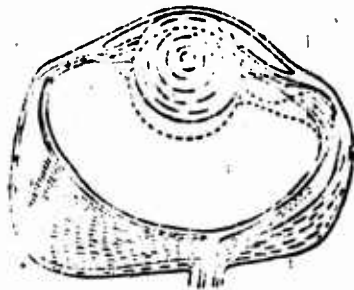

Fig. 52. Sectional view of a fish eye.

But how do fish get by without such windows? Here nature has provided the solution. Figure 52 shows a sectional view of a fish eye. The first thing that catches our attention is the spherical shape of the crystalline lens, enabling the fish to perceive distinctly objects at short range (about 1 m). Because of its special accommodation mechanism the crystalline lens is capable of moving in the eye and of assuming the position shown by the broken line in the diagram. At the same time, the fish enjoys good vision at greater distances as well (the maximum range of fish vision is no more than 15 m). Comparative data on the view field of the human and the fish are presented below.

<u>View Field</u>	Horizontal	Vertical	Binocular
Man.....	154°	135°	125°
Fish.....	160-170°	150°	20-30°

This specific structure of its eye enables the fish, even when at rest, to see a greater area of the surrounding environment.

The light-sensitive elements of the fish eye are also rods and cones. However, here also nature has sharply differentiated the sight organs of different species of fish. In the bathophilous (deep-water) inhabitants of the sea the cones are missing. They are simply not needed - the negligible amount of daylight reaching these depths is detected by the rods alone. At the same time, the spectral sensitivity curve of the eye of the cod, the anchovy, the trachurus, the gray mullet, and certain other species of fish inhabiting the upper layers of the sea is close to the visibility curve of the human eye.

In certain species of bathophilous fish there may be as many as 20 million rods in one square millimeter of retina. Experiments have shown that fish are capable of perceiving light whose intensity is only 10^{-10} of the natural illuminance on the surface of the sea. It is not impossible that the eyes of certain fish react to light of even less intensity. High-intensity light, on the other hand, may prove fatal to fish of this kind. This phenomenon is commonly referred to as photophobia, that is, fear of light.

An interesting effect is also observed in the dimensional variation of the eye as a function of depth. This effect has a dual manifestation - either in an increase in eye size or in the virtually total absence of organs of sight. Usually the increase in the size of the eye is found in fish dwelling at depths at which there is still some, albeit negligible, natural illumination. As a rule, in the case of extreme deep-water fish the eyes grow smaller and for many species are altogether missing.

The eye diameter of certain bathophilous fish accounts for 40-50% of the length of the head. The pupil is elongated in form, its edges extending beyond the crystalline lens. The result is increased eye sensitivity. There are fish whose eyes incorporate

a glowing organ that constantly stimulates the retina, thereby augmenting its sensitivity. The telescopically shaped eyes of many fish also provide increased sensitivity and expanded view field.

Writing on this subject, the American author R. Carrington notes: "For many ultrabathophilous animals the eyes are small or completely atrophied. In this zone the natural light source consists of naturally luminescent matter, so that the function of the eye consists in the perception of signals and not the form of the object. Thus, in the *Cetomimus*, which measures 10 cm in length, the eyes are 1 mm in diameter, while for the eel *Cyema atrum* the ratio between eye diameter and body length is even smaller. Some ultradeep-water fish have no eyes at all. In such instances, the optic nerve is frequently located on the surface of the head at the spot where the eye would otherwise be, and receives light impulses directly¹."

From this discussion we may conclude as follows: many kinds of deep-water fish require an eye not so much to see as to perceive light signals. What type of signals are these?

More than 50% of marine organisms possess luminescence-producing organs. These organs vary widely - from cutaneous mucous glands containing phosphorescent matter to devices reminiscent of searchlights. Occasionally, such a "searchlight"-like organ may be located in the mouth of the fish, who uses it to attract prey. In certain cases the fish's luminescent organs may function as headlights, with the creature able to turn them on and off at will, in addition to varying the direction of the beam for the

¹R. Kerrington /R. Carrington/. Biografiya morya /Biography of the Sea/. L., Gidrometeoizdat, 1966 (in Russian).

purpose of illuminating the space surrounding it. In the darkness of the great depths these glow-producing organs, in concert with the sight organs, enable fish swimming in schools to distinguish their own kind.

The remarks made above by no means cover the entire variety of eye structures found in different species of fish. There are fish (surface-swimmers) whose eye design permits simultaneous vision in the water and in the air. In such species the eye is horizontally partitioned into two halves. The upper ("air") portion of the crystalline lens is flatter in form, approximating the shape of the crystalline lens of the human eye. One species of tropical fish, the "sea dog," has a vertically partitioned eye. These creatures view their surroundings by protruding the front part of their heads out of the water.

But can a fish lacking the universal eyes of certain of its fellows also see what is taking place in the air above him? Because of the total internal reflection of the light by the surface of the water such a fish will see only those objects which are situated at an angle no greater than 48° to the eye's vertical. At the same time, the fish's eye is also capable of perceiving the image of objects located in the water and reflected from its surface. How this takes place is graphically shown in Fig. 53.

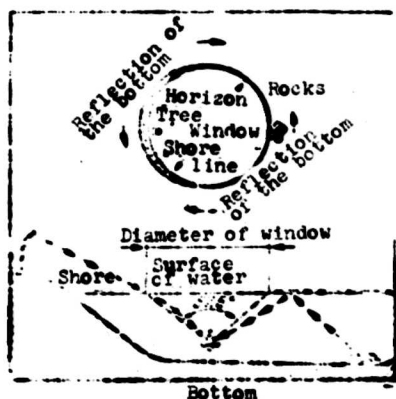

Fig. 53. What a fish sees from under the water.

The capability of witnessing events within the sea is not restricted to the eye of the fish or the glass-protected eye of man - modern science, with its underwater television camera, has also provided a means of observing the life of the deep. But of this later on. For the moment, let us consider what it means to see an object submerged in the sea.

Could Captain Nemo See a Half-Mile in the Sea?

In the film The Invisible Man various objects are seen spontaneously changing places. How were the cameramen able to achieve the necessary visual effects in the filming of this famous science-fiction novel by H. G. Wells? The actor was dressed in a black satin costume which covered his body, including his face and hands, with the filming performed against a wall similarly draped in black velvet. The black satin surface reflects very little light - that is, its brightness is very low. In addition, provided their brightness levels are equal, the viewer is unable to detect one piece of velvet against the background of another piece. The fundamental reason is the absence of a brightness contrast between the object being viewed and the background. Our eye, it develops, recognizes objects only if their brightness and the brightness of the background against which they are projected do not coincide. Is it possible, however, that there may be conditions when objects are still discernible even though their brightness is identical to the brightness of the background? This happens if the object viewed and the background are of different color - that is, if there exists between them a color contrast.

Under the conditions of the comparatively low illumination intensity levels in the sea (where it is mainly not the color-discerning cones which are operative, but the rods), brightness contrast is of far greater importance to vision than color contrast. Numerically, the value of the brightness contrast can be expressed by a simple formula:

$$K = \frac{B_b - B_o}{B_b} = 1 - \frac{B_o}{B_b},$$

where B_b is the brightness of the mass of the sea (background), and B_o is the brightness of the object which is being viewed against this background.

If the brightness of the object is greater than the brightness of the background, then the formula appears as follows:

$$K = \frac{B_o - B_b}{B_b} = \frac{B_o}{B_b} - 1.$$

These formulas demonstrate that the eye is capable of appreciating only the difference in the brightness of the object and the background, but that it is not able to determine how many times brighter is the background (or the object).

Contrast is normally evaluated in percent. If a piece of black velvet with a virtually zero brightness ($B_b = 0$) is laid on a sheet of well lit paper, then

$$K = 1 - \frac{0}{B_b} = 1 \text{ or } 100\%$$

that is, the piece of velvet will be clearly visible.

Returning to the example of the film The Invisible Man, we can also arrive at a quantitative determination of the contrast (the brightness of the costume and the draping was identical, that is $B_o = B_b$):

$$K = 1 - \frac{B_b}{B_b} = 1 - 1 = 0.$$

In actual practice, in order that an object not be visible against some background, the contrast need not necessarily equal 0. The human eye ceases to discern an object if the contrast does not exceed 2%. This is the so-called contrast sensitivity threshold of the eye. This factor is not constant; it differs in different people, depends on the conditions of observation, and may vary as a function of eye fatigue and even the mood of the individual. On occasion, the contrast sensitivity threshold may even reach a value of 5%.

What are the contrast values we are dealing with in the sea? We know that the sea's brightness coefficient is close to 0.02. Submerge in the sea an object painted with the best grade of white paint. The white surface reflects most of the rays incident to it, that is, it has a brightness factor of close to one (let's say 0.90). Then,

$$K = \frac{r_o - r_b}{r_b} = \frac{r_o}{r_b} - 1 = \frac{0.9}{0.02} - 1 = 44\%.$$

Here the contrast has been determined not according to the absolute values of the brightness, but according to its coefficients. The resultant value describes what for all practical purposes is the limit contrast capable of being observed in the sea, since all objects not painted white exhibit a brightness factor which is less than for a white surface.

Consider one further example. Assume that some object that we are observing under water has been colored with a very dark paint having a brightness factor of 0.02, that is, equal to the brightness factor of the sea. Consequently, in this case the contrast is zero and we cannot see the object in question. But if

this object is a submarine, would this mean that the creation of an "invisible sub" is actually feasible? For all its attractiveness, this idea belongs solely to the realm of science fiction. The point that must not be forgotten is that in addition to the brightness contrast there is also the color contrast. In other words, for an "invisible submarine" to become a reality, it would be necessary not only to paint it with a brightness factor equal to that of the sea, but to satisfy another condition as well. The spectral composition of this paint must coincide with absolute faithfulness with the spectral composition of the light traveling from the depths of the sea toward its surface. It is precisely under these conditions that there will be an absence not only of brightness, but also of color contrast as well. It must be acknowledged that the difficulty of manufacturing this kind of dark paint, having moreover the required spectral composition, is beyond today's state of the art. In addition, as we are aware, the spectral brightness factor curves differ for different seas and oceans. Still, let us assume that some day a paint meeting all the pertinent requirements will be produced. Will this mean that objects painted with it will be absolutely invisible in the water, that is, will have a foolproof camouflage? By no means.

In effect, the sea's brightness factor constantly changes, and these, albeit minor, changes have an effect on the contrast value. Therefore, absolute camouflage for an object situated under water is a physical impossibility. All that can be hoped for is the creation of a paint which will maximally impede the visual observation of the object - that is, the maximum possible approximation of the contrast to the zero value.

The most skilled master of camouflage is very likely nature. The majority of the denizens of the deep have been given the ability to adapt their coloring to their background (Fig. 54). Man, quite naturally, tries to keep up with nature. For purposes of camouflage, the submarines of all the navies of the world are

normally painted with a brightness factor approximating, as far as possible, the spectral coefficient of brightness of the sea.

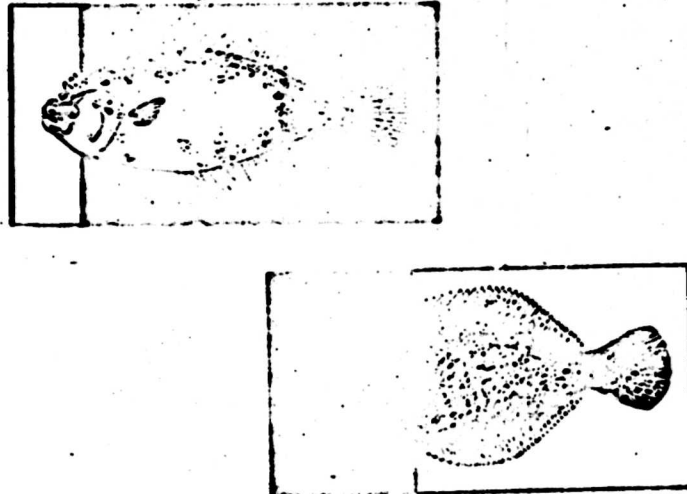

Fig. 54. A flounder changes its color.

Our entire discussion on contrast has dealt with the case when the observer is situated in the immediate vicinity of the object he is observing, that is, the contrast he observed was real. As the distance from the object grows larger, the contrast grows fainter, that is, an underwater observer at some distance from the object will be faced not with the real, but with the apparent difference in the brightness levels of the object and background - the so-called apparent contrast. This change in the contrast value is of paramount importance to underwater vision. It has been experimentally demonstrated that, with horizontal viewing, the variation in actual contrast follows Bouguer's law:

$K_a = K_r \cdot 10^{-\epsilon z}$, where K_a is the apparent contrast, K_r is the real contrast, z is the distance from the observer to the object, and ϵ is the attenuation index of the radiation directed from the object to the eye of the observer.

The distinguishing feature of observation conditions in water and air lies in the fact that the attenuation index of sea water is hundreds of times greater than that of air. Light scattering by the water leads not only to attenuation of the direct beam traveling from the object to the observer, but also creates between them a kind of luminous haze which veils the object under observation and impedes its visibility.

This haze gives rise to very serious problems in underwater operations involving artificial light sources. It would seem that the more powerful the searchlight used to illuminate an object under water, the more visible it will be, but this is far from the truth. Increasing the searchlight power, although it does improve the illumination of the object's surface, simultaneously results in increased haze intensity. For this reason, searchlights with an output of 1-3 kW are customarily employed in different underwater operations, the aim being to bring the light source as close as possible to the object. In addition, visibility is improved if the object is illuminated, as it were, from the side, that is, if the angle made by the sighting line and the projector beam is on the large side. The least favorable will be the observation conditions along the beam, since in this case the haze intensity is maximum.

At what underwater distance, then, can a comparatively large object illuminated by a searchlight be seen? In Jules Verne's well known novel Twenty Thousand Leagues Under The Sea there are the following lines: "... for underway orientation one requires a light to cut through the gloom... Behind the conning tower was mounted a powerful electrical projector, which lit up the sea at a distance of a half-mile¹."

¹Zh. Vern J. Verne. Collected Works, Vol. 4, M., GIKhL, 1956 (in Russian).

We know that Jules Verne had a brilliant gift for predicting technological developments many years in advance. At the time his book was published there could be no thought of using electric energy for submarine propulsion - even the electric light bulb had yet to be invented. But let us assume that the "Nautilus" actually did mount a high-power searchlight. Could it have illuminated the sea at a distance of a half-mile from the vessel, and what then would the observer have seen? Let us attempt at least an approximate calculation of the portion of the light's radiation which could reach the surface of an object located a half-mile away from it (0.5 nautical mile = 926 m).

Assume that the "Nautilus" was submerged at night (this to exclude the effect of daylight) in very transparent ocean waters. For such waters the attenuation index of directional radiation ϵ is close to 0.1 m^{-1} , and the attenuation index of scattered radiation α is close to 0.015 m^{-1} .

Experimental studies conducted by Soviet hydrooptical investigators M. N. Bulkhurgin and V. P. Nikolayev have shown that at distances not exceeding the disappearance depth of the white disk the intensity attenuation of a projector (searchlight) beam is governed by Bouguet's law: $I_z = I_0 \cdot 10^{-\epsilon z}$. At greater distances the now scattered ray is likewise attenuated according to Bouger's law, but with the scattered-light attenuation index:

$$I'_z = I'_0 \cdot 10^{-\alpha z}.$$

In clear ocean waters the disappearance depth of the white disk is approximately 40 m. We substitute in the equations the data available to us, taking the initial intensity of the projector (I_0) to be equal to 1:

$$I_z = 1 \cdot 10^{-0.1 \cdot 40} = \frac{1}{10,000}.$$

Thus, at a distance of 40 m from the projector the intensity of its light is only 1/10,000 of the initial intensity. Further:

$$I'_z = I'_0 \cdot 10^{-\alpha z} = 0.0001 \cdot 10^{-0.015 \cdot 886} =$$

$$= 0.0001 = \frac{1}{100,000,000,000,000}$$

In practical terms it is literally impossible to conceive of the incredibly infinitesimal portion of light which even in extremely transparent water would reach from the searchlight of the "Nautilus" to an object a half-mile distant from it. But even in the event the searchlight were close by the object and illuminating it thoroughly, still at that distance the light reflected by the object could not possibly reach the observer.

The real range of visibility in different seas, under conditions of artificial illumination, is primarily determined by the reflective capacity (reflectance) of the observed object and the transparency (transmittance) of the water, and hardly ever will exceed 50-60 m.

Interesting information on natural-light underwater visibility has recently been published by the American investigator R. F. Busby. For example, in the Miami region at a depth of 305 m observers in a bathyscaphe were able to see the bottom from a distance of 5-6 m. Off the coast of California, west of San Diego, horizontal visibility about 185 m down range from 9 to 15 m. Unexpectedly good visibility was noted off the Florida coast, where from a depth of 190 m the floor 55 m below was clearly discernible.

In underwater natural-light observations the range of visibility depends in large measure on the angle at which the object is viewed. This results from the fact that in the upper sea layers, where the light has not yet been completely scattered, the background brightness differs in different directions, which has an effect on the value of the contrast. In addition, this also occasions a difference in the brightness of the obscuring haze as a function of the direction.

Investigations performed by O. A. Sokolov on the submarine "Severyanka" indicated that in the surface layers of the sea the range of downward visibility in transparent waters may be as much as 100 m and more.

In studies of the optical properties of sea and ocean waters extensive use is made of data derived from the visibility of objects submerged in the sea. The first efforts to arrive at a transparency value for sea water were made with submerged disks. The standard white disk (Secchi disk) is still used in most oceanographic expeditions even today for relative transmittance readings. Note that we have quite deliberately used the term "relative transmittance." Although the depth at which the disk can no longer be seen (disk disappearance depth) depends mainly on the transmittance (transparency), it does not provide a quantitative definition of the physical value of transmittance which we have been discussing above. Nevertheless, disk readings are of definite assistance in ascertaining the optical properties of the waters of different seas and oceans. Here our major interest is in the question of the disk's visibility under water. Why does the observer at some point no longer see it?

Primarily, the apparent contrast between the disk and the background. The brightness factor of the standard white disk is about 0.80. Using the formula with which we are already acquainted, let us determine the real contrast between the two:

$$K_r = \frac{r_{wd} - r_b}{r_b} = \frac{0.8}{0.02} - 1 = 39\%, \text{ or } 0.39.$$

The deeper the disk is submerged in the sea, the more this contrast is attenuated. The contrast that will be seen by the observer depends on two factors: the attenuation index ϵ (that is, the transparency of the water) and the depth z at which the disk is located at a given moment - that is,

$$K_a = 0.39 \cdot 10^{-\epsilon z}.$$

In other words, the more turbid the water and thus the greater the value ϵ , the less the depth at which the apparent contrast reaches the value of the contrast sensitivity threshold of the eye (i.e., 0.02) and the observer loses his ability to see the disk.

Using these two formulas it would seem to be a simple matter indeed to make an accurate determination of the depth of disappearance not only of the white disk but of any object whatever, merely by assigning the values of the real contrast and attenuation index. However, we have completely disregarded a number of factors which have a negative effect on visibility: the variation of the angular dimensions of the disk as it draws away from the observer, the level of illuminance vs depth, and the disturbance on the sea surface. Consider the influence of each of these factors separately.

Specially conducted experimental studies have shown that if the angular dimensions of a viewed object become smaller than 1° ,

the contrast sensitivity threshold rises abruptly. The diameter of the standard disk is 30 m, and at a depth of 17 m its angular dimension is 1° . In transparent waters, however, the disk is visible at far greater distances. Therefore, in order that observation results be in genuine conformity with disk visibility in given waters, a definite relationship between disk dimensions and the depth of its disappearance must be adhered to. Thus, in very clear ocean waters where the disk is visible to depths of 50-55 m its diameter must be about 1 m.

The visibility of underwater objects in general, and the disk in particular, is greatly influenced by conditions of illumination. These conditions determine the brightness both of the objects and of the background against which the objects are projected. It is a fact, as we have seen, that as the brightness level falls, the ability to distinguish contrast visually is impaired. The same thing happens when the brightness level is significantly increased. For disk observations the former is more important since the observer will in any event not be dealing here with very elevated brightness levels. Therefore, for a proper appraisal of the disk disappearance depth, readings are taken when the surface of the sea is acceptably well illuminated.

Normally, light reflected from the sea surface and striking the eye of the observer constitutes a severe hindrance. Additionally, even a mild disturbance on the surface results in severely curtailed visibility. Because of differences in the steepness of the waves, the light rays originating from the disk are refracted differently as they pass from the water into the air, with the image of the disk constantly fading.

All the aforementioned unfavorable factors may significantly distort the measurement data of disk visibility depth and impede the collation of findings for different seas and oceans. Thus,

there are a number of rules to be followed when working with the disk. For example, readings are always taken from the shaded side of the ship least there be interference from the glare of the light reflected from the surface. No observations are to be made when the disturbance exceeds three points. Occasionally, to avoid the effect of glare, the disk is observed through an internally blackened box, which is partially submerged beneath the surface of the sea. Observations are not conducted at dawn or twilight, but are timed to coincide with the bright period of the day.

There exists in meteorology the concept "meteorological range of visibility." This term is taken to mean the distance beginning with which, under the effect of haze, there is a loss of visibility of a black object projected against the background of the sky and having at the visibility-range-distance angular dimensions of no less than 20 minutes. In marine optics, although far less often than in meteorology, the concept of the "hydrological visibility range" is also encountered. No strict definition of this term actually exists. It is occasionally understood as the disappearance depth of the standard white disk, and occasionally of the black.

American specialists in the field of hydrooptics consider the visibility range to be the distance at which the initial (original) contrast decreases to $1/50$ of its value. To measure the hydrological range they have proposed a device consisting of two coaxial disks, one of which is white and the other, of smaller diameter, gray. The distance along the vertical between the disks (adjustable from the deck) is so selected that their brightness appears identical to an observer standing on the deck. Naturally, the white disk is lower in the water than the gray. By knowing the reflection factors of both disks and the difference in their depth, the hydrological visibility range can be easily computed.

Interesting observations are also possible with a black disk. There is a very simple formula which makes possible, based on the depth of its disappearance, a fairly accurate determination of the attenuation index ϵ . The formula appears as follows:

$$z_{bd} = \frac{1}{\epsilon} \cdot \log \frac{1}{T},$$

where z_{bd} is the disappearance depth of the black disk (m); ϵ is the attenuation index of directional radiation (m^{-1}); T is the contrast sensitivity threshold of the eye.

Taking T as equal to 0.02, we have

$$z_{bd} = \frac{1}{\epsilon} \cdot \log 50 = \frac{1.7}{\epsilon}.$$

This method of determining the attenuation index is known as the black screen method.

The study of underwater visibility is one of the most interesting and important problems of marine optics.

MARINE OPTICS AND UNDERWATER PHOTOGRAPHY

A Camera on the Bottom

In 1893, in Bainlieu-sur-Mer Bay on the Mediterranean, the French scientist Louis Boutan succeeded in taking the first underwater photographs. For the special purpose of underwater photography he designed his own camera, a cumbersome device which was lowered to the floor of the sea and controlled by a diver (Fig. 55).

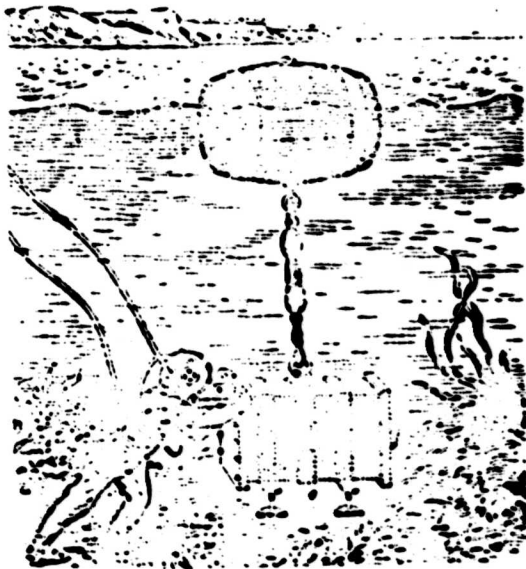

Fig. 55. First underwater photographs.

At that time photography relied on unwieldy wet-colloid plates; there were available neither light-weight cameras nor adequately powerful small-size light sources. After Boutan, therefore, only episodic attempts were made at underwater photography, and his book, La Photographie Sousmarine, written in 1900, remained known to a restricted readership.

Mass involvement with underwater photography dates back only to the thirties and the first appearance of small roll-film cameras. For shallow-water photography it was found convenient to use an ordinary camera enclosed in a watertight case with the controls externally accessible through a packing-gland arrangement. Picture-taking at the greater depths, beyond the reach even of diving-suited operators, was entrusted to special-purpose automatic cameras.

Although Boutan worked out the principal design features of this kind of camera as far back as 1899, the technical state-of-the-art of that period prevented him from putting his invention to a practical test. It was only in 1940 that the Americans Hewing, Wine, and Worzel succeeded in achieving the first quality ocean-floor photographs at great depth. The camera they developed was successfully used during the war as a means of locating sunken vessels. In the postwar period underwater photography began to find wide application in the geological and biological study of the sea bed. This technique enables scientists to observe in detail the micro-relief of the floor surface, to decipher the character of its component deposits, and to discover the outcroppings of bedrock. Ripple traces on the ocean bottom, as recorded on a photograph, serve as proof of the presence of benthonic currents, while the evidence of animal life captured within the lens view-field provides biologists with information regarding the qualitative and quantitative composition of the floor fauna and the conditions of its habitation. Still and motion-picture photography are probably the sole means of examining the traces of vital activity of those creatures of the deep normally not encountered in trawl-sweep and bottom-sampling surveys.

The depth record for underwater photography climbed rapidly. In 1951 an American scientist, David Owen, photographed the ocean floor from a depth of 5500 meters. In 1959 his fellow-countryman,

Harold Edgerton, succeeded in photographing the sea bottom from 8500 m. A Soviet researcher, N. L. Zenkevich, having lowered a camera to the bottom of the Kermadec Trench in the Pacific at a depth of 9960 m, obtained only blurred photographs of suspended matter and slime, since the trench floor was totally covered by liquid ooze, into which the camera evidently completely disappeared. Zenkevich did achieve good ocean-floor photographs in the Pacific at depths to 6150 m. He designed and constructed a twin-lens underwater camera for stereoscopic photography of the sea bottom. Figure 56 shows a rocky bottom virtually devoid of a sedimentary cover. Accumulations of globigerinal sand, whitish in color, can be seen only in a few shallow depressions. A few large ophiuroids are lying on the surface of the floor. From a floor of this kind conventional soil-sampling devices are usually retrieved empty.

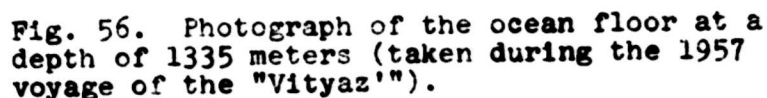

Fig. 56. Photograph of the ocean floor at a depth of 1335 meters (taken during the 1957 voyage of the "Vityaz").

Stereoscopic photographic equipment of the Zenkevich system has been successfully used on expeditions by the Institute of Oceanology and has provided marine geologists and biologists with invaluable material.

Opening any book on underwater still and motion-picture photography or underwater television we are certain to discover a chapter which discusses the optical properties of the aqueous medium and the laws of light propagation in water. The ability to understand the peculiarities in the passage of light through the sea surface and its propagation in the sea is indispensable both when photographing objects through the surface and when working with an actually submerged camera.

In photography through the surface the refraction of the rays traveling from the water into the air may noticeably distort the proportions of the underwater objects along with their relative position (Fig. 57). The effect of refraction appears to be to elevate all submerged objects above their true position. The greater the surface angle traveled by the rays, the more pronounced will be this effect. In shallow water an absolutely flat bottom photographed through the surface will appear concave in the picture: the depth will seem greater in the center of the photograph and less at the edges.

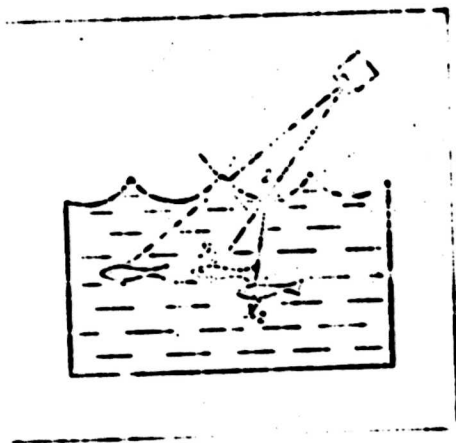

Fig. 57. The refraction of light rays passing through the surface noticeably distorts the proportions of underwater objects.

In color photography the color reflected from the sea surface normally degrades the color contrast of the objects in the photograph (Fig. 58.1). The laws of optics suggest how this effect is to be countered. We know that the light reflected from the surface is polarized and, consequently, can be easily "cut off" by means of a polaroid lens. By placing ahead of the lens a polarization filter, we sharply reduce the white background in our picture, thus restoring the richness in the coloration of the underwater objects to be photographed (Fig. 58, 2).

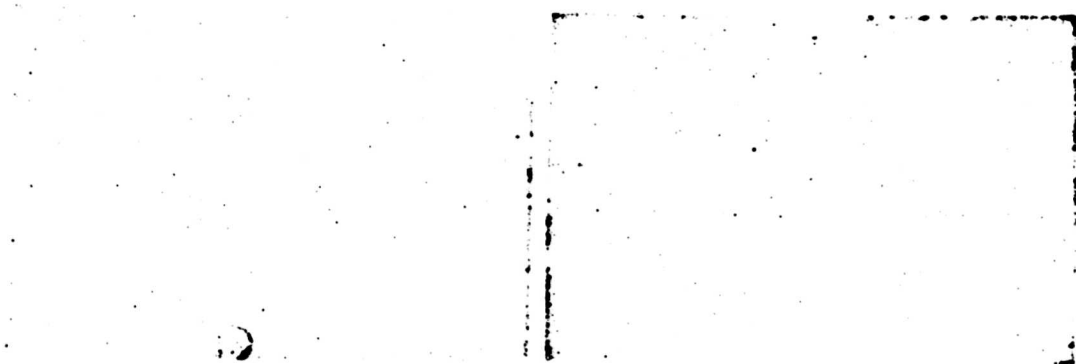

Fig. 58. Surface-reflected light sharply reduced the contrast on the film (1). A polaroid filter combats harmful effect of reflected light (2).

Another method of coping with the light reflected from the surface of the water is to lower the lens under water. However, even disregarding the effects caused by the scattering and selective absorption of light by the sea water, still, because of the difference in the refractive indices of water and air, the conditions of underwater photography will differ substantially from those which characterize picture-taking in an air environment.

The inner workings of the camera are separated from the water by the glass of the viewing opening. This viewing opening or "window" is normally fashioned so as to be flat - that is, the rays striking the lens pass through a plane-parallel glass plate with air on one side and water on the other (Fig. 59). Such rays are refracted twice - on the water/glass boundary and on the glass/air boundary. Based on the refraction law we can write:

$n_{\text{water}} \cdot \sin \varphi_1 = n_{\text{glass}} \cdot \sin \varphi_2$ and $n_{\text{glass}} \cdot \sin \varphi_2 = n_{\text{air}} \cdot \sin \varphi_3$, where n_{water} , n_{glass} , and n_{air} are, respectively, the indices of refraction of water, glass, and air. Excluding from these equations the intermediate medium - glass - we obtain

$$n_{\text{water}} \cdot \sin \varphi_1 = n_{\text{air}} \cdot \sin \varphi_3,$$

whence

$$\frac{\sin \varphi_1}{\sin \varphi_3} = \frac{n_{\text{air}}}{n_{\text{water}}} = \frac{1}{n},$$

where n is the relative refractive index of the water with respect to the air.

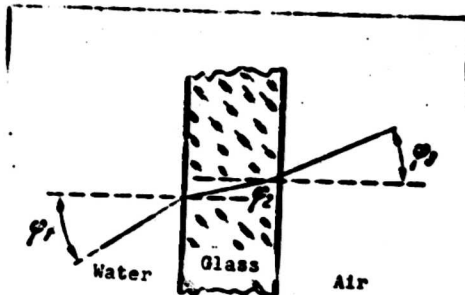

Fig. 59. Refraction of rays passing through the glass of a flat port hole: φ_1 - angle of incidence of the rays from the water to the glass; φ_2 - refraction angle of the rays in the glass; φ_3 - angle at which the rays penetrate the chamber.

Thus, regardless of the material of the viewing window, the sine of the angle at which the ray strikes the surface of the window from the water will be approximately only 3/4 of the sine of the angle of incidence of the ray from the air ($\sin \phi_1 = \frac{1}{n} \sin \phi_3 = 0.75 \sin \phi_3$, since the refractive index of sea water with respect to air n equals 1.34). Therefore, there is a reduction in the lens's angular viewfield in water. For example, for the "Yupiter-12" lens, which as a 63° in the air, the angular coverage in water is only 47° .

Light ray refraction in the passage from the water to the inside of the camera results in the fact that, in water, all objects appear 1/4 larger, and the distance to them 1/4 shorter, than in reality. This is precisely the way things look to a skin-diver in his underwater goggles (without which he would of course be blind) - or the way they are impressed on a film by a lens through a flat window. When estimating the distance under water to an object by eye, the photographer gets sharp pictures because both he and the camera are equally in error as to the real range. When an automatic camera is used, the lens automatically focuses on a distance which is 3/4 of the real distance. The effect under water is that of an increase in the focal length of the lens.

In order to minimize the attenuation by the water of the object's visible brightness and the blurring of its outline by the scattering-caused light haze, underwater objects should be photographed at close range. Here an important point is that the lens have sufficient wide-angularity to take in the entire area of interest at close distances to the object. This is the reason why normally in underwater photograph short-focus wide-angle lenses are employed. An additional advantage these lenses afford over ordinary lenses is their greater depth of field,

an especially important factor in automatic photography in the sea when there is no way of predetermining the distance to the subject.

Unfortunately, the wide-angle lens also has its shortcomings, and they are serious ones. The greater the angle at which the ray strikes the surface of the glass, the greater the difference in the refraction of light rays of different wavelength, resulting ultimately in chromatic aberrations¹. As the angle of inclination of the rays increases, the glass of the flat viewing opening admits less light, with the result that the edges of the finished picture are darker.

How then are we to escape what in this case is the near-fatal effect of light ray refraction? The most radical solution to the problem would be to fill with water the inner workings of the camera - naturally, not a conventional camera since the glass optics of this kind of lens would be inoperative in water. The difference in the refraction indices of the water and glass is far too negligible, and the photograph would record just about the same picture as seen by a diver without goggles. The practical implementation of this idea requires the use of the simplest type of camera obscura with a hole drilled in a metal plate instead of a lens. If the entire space between the aperture and the light-sensitive plate is filled with water, the light rays striking the plate will be free of any refraction.

Although a device of this kind is adequate to produce quite satisfactory pictures of the underwater world, the possibilities of so primitive a camera are obviously severely limited. Is there then no other way of dealing with the refraction problem? It

¹Chromatic aberration refers to image distortion due to differences in the refraction of light waves of different wavelength.

turns out that there is. By using a system with a spherical viewing window and by locating the optical center of the lens in the center of the sphere, the majority of the rays striking the lens and generating an image of the object on the film will strike the window perpendicular to its spherical surface. Such a ray, as we are aware, passes through the glass without refraction (since if the angle of incidence of the ray is zero, the refraction angle will also be zero). The spherical window offers one other advantage over the flat - greater mechanical strength - something that is particularly important when photographing at great depths when the pressure on the viewing glass may reach figures of several tons.

When a spherical viewing aperture is used, the optical center of the lens must be located precisely at the center of the sphere. If the lens is even slightly off-centered with respect to the sphere, there will be severe distortion in rays striking at large angles. Since such off-centering of the lens is not entirely avoidable (if for no other reason than because of temperature deformation), some means of eliminating these distortions must be found. The American optics specialist Thorndyke has proposed the use of a corrective lens for this purpose. Chromatic aberrations are neutralized by filters which admit only that portion of the spectrum which approximates the spectral sensitivity of black-and-white film.

Optical underwater photography systems developed by the famous French hydrooptical expert A. A. Ivanoff (Fig. 60) are in wide use. Attachments designed according to his principle ensure a quality image over the entire frame together with an acceptably wide view angle. Moreover, no particular precision is required in the centering of the lens with respect to the attachment, with the system tolerating minor displacements of the lens along the optical axis and to either side of it.

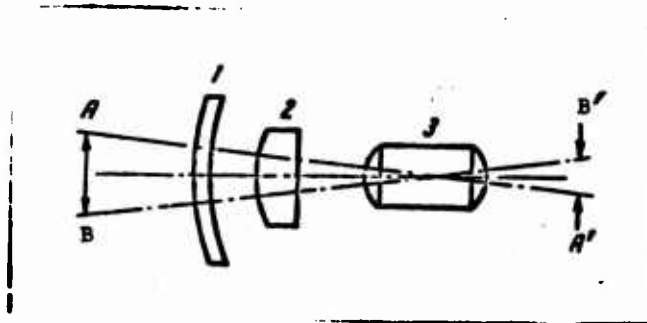

Fig. 60. The optical system of A. A. Ivanoff:
 1 - window (negative lens); A'B' - object image;
 2 - compensating positive lens; 3 - objective;
 AB - underwater object to be photographed.

Excellent operational performance is the hallmark of the Soviet-produced "Gidrorussary" underwater-photography lenses. Despite the large angular view field of these lenses, when used in underwater filming through a flat porthole they are virtually free of distortion. Credit for the optical concept of this system belongs to the Leningrad optician M. M. Rusinov. The essential idea here is that the water-flat window system functions, as it were, as one of the lenses, while the objective is designed to correct the latter's distortions. A great advantage of this scheme lies in the fact that the objective may be freely positioned with respect to the plane of the window.

Range of photography depends primarily on the distance at which objects are visible under water. This latter distance, we know, is determined by several factors: the illumination of the object, the attenuation of its visible brightness by the water, and the blurring of the outline of the object by the scattering-induced light haze. The possibility of natural-light photography is severely limited by depth. In transparent waters with bright sunlight the limiting depth for photography may be several tens of meters, while in turbid waters it is impossible to determine the location of the Sun-illuminated sea surface at even a very shallow depth.

Artificial lighting is used to increase the illumination intensity of the objects to be photographed. Incandescent lamps are widely employed in underwater motion-picture filming. These lamps are powered either over a cable from the surface or from underwater storage batteries. The best source of illumination for underwater photography is the electronic flash lamp. This device provides a short but powerful burst of brilliant light very close in spectral composition to sunlight. The exposure in the case of artificial lighting depends on the sensitivity of the film, the output of the lamp (or lamps), the transmittance of the water, and the total pathlength of the light in the water. With natural lighting the total path of the light consists of the distances from the object to the surface and from the object to the camera (Fig. 61). With artificial lighting this path equals the sum of the distances from the light source to the object and from the object to the camera.

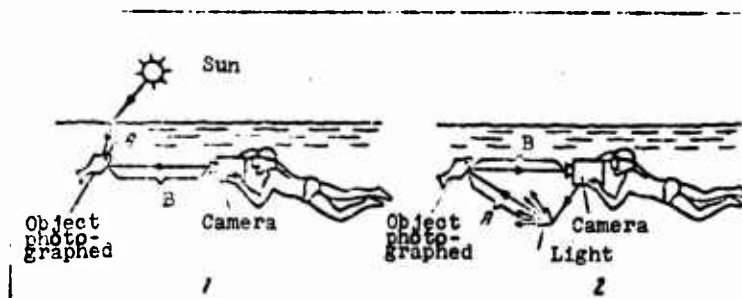

Fig. 61. Total path of light in underwater photography: $A + B$. 1 - with natural light; 2 - with artificial light.

To reduce the haze caused by the scattering in the water of the rays from the light source, the latter should be located as close as possible to the object to be photographed. Normally, the source is set up at an angle to the axis of photography in order to avoid the direct illumination of the medium between the object

and the camera. The preference here should be given to spotlights, which provide a brilliant narrow beam, and not to general-purpose wide-angle lamps. The accuracy of this conclusion is confirmed by an incident described by A. A. Rogov:

"Working in Riga harbor in the fall of 1962 in water of very low transparency, photographers of the underwater research group 'Soyuzmorniprojekt' used two auxiliary light sources: PPS-100 underwater lighting devices with 1000-W incandescent lamps and underwater spotlights with 6-W lamps. Filming was through a container filled with distilled water, with the object of the photography independently illuminated.

"The effect of the lighting was unexpected. By lighting up the background between the object and the camera, the underwater lighting device, with its almost ten-times-greater intensity than the spotlight, created a cone of light with a solid angle of 120° . The height of the cone in this case did not exceed 100-150 cm, but because of the severe scattering of the light the objects illuminated were poorly visible. On the other hand, the ray from the spotlight, with a scattering angle of no more than 5° , provided rather good lighting of the objects at the same distance. Unlike the lamp arrangement, the beam from the spotlight was not blinding and did not interfere with observation of the filming procedure."

Because of the increase in the light background which attenuates the contrast of the object, boosting the power of the illuminating device results in at best a negligible improvement in the visibility of underwater objects. Assuming an optimal arrangement for the lighting units, increasing their output by 10 times provides only a 15% greater range of visibility.

¹A. A. Rogov. Fotos'yemka pod vodoy /Filming Under Water/, M., 1964.

In the view of certain specialists there is a relationship between the range of visibility and the range of photography: $l = 0.5 z$, where l is the range of photography, and z is the horizontal range of visibility of the standard white disk. Underwater investigators have on repeated occasions received practical confirmation to the effect that objects under water which were perfectly visible to the naked eye exhibited a decided lack of contrast when recorded on film.

What then is the procedure to be followed when photographing in very turbid water? Even by using every possible device for photographic enhancement, satisfactory pictures can be achieved only in those cases when the depth of visibility as measured by the white disk is no less than 1.5-2 m. On the other hand, there are bodies of water so contaminated by suspended particles and dissolved substances that white-disk visibility range falls short of even 1 m. Water of such low transparency is commonly encountered in ports, where precisely there is a very frequent need for underwater photography (in the case of damage to wharves, piers, breakwaters, and the like). Fortunately, engineers and scientists have found a way to circumvent these difficulties. For picture-taking in very turbid water they have proposed the use of special adaptors designed in the form of truncated pyramids or cones filled with some transparent liquid or air (Fig. 62). The filming process in this case is in effect conducted through the thin layer of turbid water located between the protective glass and the object. The container holding the liquid filling agent can be easily sealed and submerged to the required depth. On the other hand, this container is subject to shortcomings not experienced with the air container. First of all, for an object of the same area (and for the same lens), the water pyramid must be $1/4$ higher than the air pyramid, the reason being that when filming through air the lens's view-field angle will not decrease. An increase in height, when the bases remain equal, results in a sizable increase in volume.

For example, to photograph an underwater object having an area of $0.6 \times 0.9 \text{ m}^2$, the volume of the water pyramid would have to equal 300-350 l.

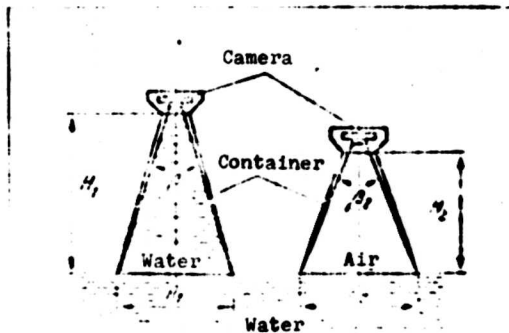

Fig. 62. Adapters for photography in turbid water: a - water filler container; b - air filler container $A_1 = A_2$, but $\beta_1 < \beta_2$ and thus $H_1 > H_2$.

There are problems in maintaining this amount of liquid in a state of ideal purity, not to mention the difficulty of transporting it. Therefore, in place of liquid containers, specialists often resort to special adaptors produced from monolythic pieces of transparent organic glass. The choice of one or another kind of adaptor is dictated by the specific nature of the work and by the conditions under which the filming is to be performed - notably, by the depth of the objects to be photographed. Such adaptors can be used to achieve high-quality pictures even in waters of extreme turbidity.

We know that sea water attenuates light rays differently; the spectral composition of sunlight also changes with depth as a function of wavelength. We have already discussed the unexpected color effects produced by the disappearance of the red from the light flux penetrating into the sea. Naturally, all these effects will also be evident on the film when photographing in color... although with certain reservations. The human eye is far better at distinguishing color hues than any film. Underwater photo-

graphers have frequently discovered that what they had visually observed at shallow depths as a wide range of yellows, blue, and dark greens with a multiplicity of intermediate shades came out on their film as a blurred blue-green haze.

This disturbed underwater color balance can be corrected, however, through the use of artificial light sources. Here too, of course, the aim should be to achieve the shortest possible light path in the water since otherwise the water's absorption of the red rays will again become obtrusive (Fig. 63). Even in very transparent water the overall pathlength of the light in the water should not exceed 5 m for satisfactory color reproduction of a submarine object.

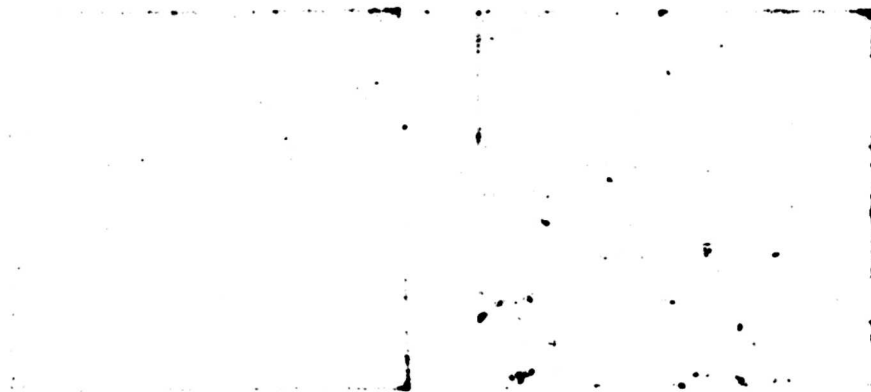

Fig. 63. Distortion by the water of the true color of an object. In white sunlight this star fish is bright red: 1 - total path of light in water is 1 m; 2 - total path of light in water is 4 m.

Another method of rendering the true colors of any photographed object is through the use of colored correction filters. Such filters are also employed in black-and-white photography where the absence of the red rays, by disrupting the color balance, lowers the image contrast. By absorbing the blues and blue-greens, these filters simultaneously eliminate the haze, which is

pale blue in shade. A similar purpose is served by working with panchromatic film having maximum color sensitivity in the orange-red region of the spectrum.

In color photography the underwater photographer is normally dealing with color film designed for the sunlight spectrum. Therefore, the correction filter must be so selected that the sum transmittance of the light by the water layer (whose thickness equals the total pathlength of the light in the water) and the filter is nonselective, that is, independent of the wavelength. Even assuming that the total path of the light in the water during the photography is always the same (say, 3 m), still in this hypothetical event it would not be possible to design a universal correcting filter - for the reason that the spectral transmittance of light differs in different waters. Each type of water would require its own correcting light filter: One with maximum absorption in the yellow-green spectral region for the more turbid waters, and in the blue for the more transparent waters (Fig. 64). In the case of artificial light sources such colored filters can also be installed directly ahead of the lamps.

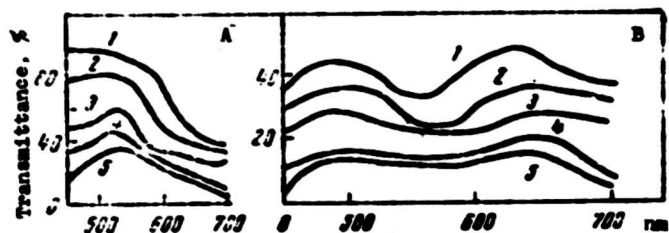

Fig. 64. Correcting the color balance under water through the use of correcting filters: 1 - pure ocean waters; 2 - ocean waters of average purity; 3 - pure coastal waters; 4 - coastal waters of average purity; 5 - turbid waters; A - spectral transmittance of different waters for a total light pathlength of 3 m; B - sum transmittance of three-meter layer of water and of a color filter (in the case of ideal correction the sum transmittance has been represented by the solid line running parallel to the horizontal axis).

The use of a correcting filter severely curtails the total transmittance of light. By equalizing the color balance, the filter cannot add red light; it merely reduces the amount of blue. Moreover, it is worthwhile remembering that there are no filters with 100% transmittance even in any one spectral segment. When a filter is used, the total quantity of light striking the film is significantly diminished. Therefore, whenever the level of illumination is low or there is a need for great depth of field, correcting light filters are not to be used.

Colored filters permit natural-light color photography at far greater depths. In effect, while pictures with satisfactory color rendition are possible in sea water without filters to depths of no more than 3-5 m, with such filters filming is easily accomplished as much as 20 m down.

Television Reporting from the Ocean Floor

All the problem areas discussed above remain substantive in the case of underwater television as well. Light-ray refraction in the passage through the pick-up camera viewing port, severe water-caused attenuation of the visible brightness of the objects, blurring of outlines by the scattering-induced luminous haze, low illumination intensity levels - underwater television technicians are inevitably confronted by all these and related problems.

Having become a reality three decades ago, at the present time underwater television is extensively used in many countries as a tool in various areas of marine research. For all this, underwater television is unquestionably inferior to underwater still and motion-picture photography, first in color rendition and second in terms of the depths accessible to observation. It is also true that while color photographs of marine life taken

at great depths have already become something of a commonplace, underwater television is still in its embryonic stages and it has only been in recent times that the use of this medium for coverage beneath the sea has been reported. Another area where television is at a considerable disadvantage with respect to conventional photography is in maximum depth of submersion - with cameras already routinely reaching the ocean's ultimate depths, until recently the one-kilometer mark stood as the limit for television.

What is the reason for this lag? The fact is that for continuous image transmission some sort of communication channel is required, and at the present time the sole communication channel in underwater television is cable. In an aquatic environment the use of radiowaves of the centimeter and meter waveband, which provide the basis for conventional TV, is impossible because of the enormous attenuation (fading). For example, radiowaves at 50 MHz are attenuated approximately 10,000 times by a stratum of water 1 m thick. Even from a depth of only a few meters a transmitter operating at this frequency will not be audible. Image transmission is feasible at longer wavelengths since the attenuation index decreases in direct proportion to the frequency. For example, radiowaves with a frequency of 5 kHz (that is, a frequency 10,000 times greater than in the foregoing example) will suffer 10,000-fold attenuation only after traversing a ten-kilometer layer of water, which is to say that their reception is possible even from the limiting depths of the ocean¹. However, at so low a frequency, retention of the normal number of frames transmitted per second is no longer possible; as a result, uninterrupted image transmission must be sacrificed in favor of the transmission, as

¹The attenuation of directional radio radiation in water is governed by the law as the attenuation of light flux:

$$I_z = I_0 \cdot 10^{-\gamma z}, \text{ where } \gamma \text{ is the attenuation index.}$$

it were, of individual instantaneous photographs of the observed object. The emission above of such radiowaves poses an arduously complex problem since the dimensions of the transmitting antenna must be commensurate with the wavelength, which for such low-frequency waves, even in water (where the wavelength is some 9 times shorter than in the air), amounts to several kilometers. The only hope of circumventing these difficulties lies in the use, as a waveguide, of a line on which the transmitting antenna can be submerged into the sea. A system of this kind might also be employed for another type of cableless transmission - ultrasonic vibrations.

The high cost of the cable, the problems of transporting it, plus the need to equip the vessel with special high-power winches for lowering and raising it - all of these factors limit the depth possibilities of television. Cable-free communication alone will enable television to take its place as a generally accepted tool of oceanic investigation alongside underwater photography and cinematography.

The fact is that the potential capabilities of underwater television far outstrip those of underwater still and motion-picture photography. This is certainly true of the range of vision. The threshold of contrast sensitivity of modern underwater television equipment is of about the same order as that of the human eye. An American researcher, G. Roberts, has estimated that it would be possible to design a television system with a contrast sensitivity threshold some three orders lower. In many instances modern electronic techniques provide a means of dealing with the optical distortions encountered. By varying in a definite manner the waveform of the scanning currents (or voltages), geometric raster distortions can be achieved of a kind which will compensate, in whole or in part, for the optical distortions of the images furnished by wide-angle lenses. Special electronic devices -

contrastors - provide partial compensation for image contrast fading caused by attenuation in the water. The maximum underwater range of vision using television equipment, as reported by the American scientist Stamp, is 45 m.

The principal advantage, however, of underwater television over either still or motion-picture photography is the possibility of continuous underwater observation. The present-day state-of-the-art of underwater television had its beginning in 1947 when American specialists mounted a pick-up camera on the deck of a submarine to study the effects of an atom bomb test explosion off Bikini atoll. At the present time underwater television is extensively used in the fishing industry, for submarine archeological research, and in underwater emergency-rescue and repair operations. Underwater television installations provide a means of observing divers in action and of conveying to them whatever instructions they might require. By mounting a special remote-controlled manipulator on the camera it is very often possible to dispense with the services of the divers altogether. There already exist "mechanical arms" capable of performing the simplest kinds of operations under water: the catching of small animals within the view-field of the camera, the sampling of bottom vegetation, and the lifting of various objects from the ocean floor (Fig. 65).



Fig. 65. An underwater "telerobot" - an IOAN-5 camera with a "mechanical hand" mounted on its casing.

One of the first Soviet systems of this type - the IOAN-3, developed by N. V. Vershinskiy and V. I. Marakuyev - assisted in the investigation of the sunken vessel "Desna." The advanced French petroleum telediver "Telenaut" has already "learned" to screw nuts, and, in addition to its television transmitter, is also equipped with a motion-picture camera. Indeed, the time is not far off when underwater telerobots, obedient to the will and commands of man, will be able to carry out his most varied assignments at any ocean depths.

LIGHT AND LIFE IN THE SEA

Light has a decisive effect on the evolution of life in the ocean. The illumination of the mass of ocean water by the sunlight is of colossal importance to the development of a variety of biological phenomena. Thus, sunlight energy is present in the photosynthesis process involving the conversion of inorganic matter to organic.

The variation in the intensity of illumination during the twenty-four-hour period is responsible for the diurnal vertical migration of plankton. The depth-related change in the amount and spectral composition of the light is reflected in the coloring of algae and animal life. Moonlight, for example, plays a special and in many ways still enigmatic role in the biological rhythms of marine creatures.

By indirectly affecting the vision of sea organisms, natural light enables them to find their way in space. It is still not entirely clear to what depths marine animals and fish can detect light. An American biophysicist, Clark, believes that for many fish a depth of 750 m is the limit, while a colleague of his, Waterman, would set this boundary at up to 1500 m for crustaceans.

In the dark depths of the ocean, where the role of warm life-giving sunlight is infinitesimal, we enter the realm of the cold light of the sea - bioluminescence, the glow of marine organisms. Certain negative effects of light, for that matter, have also been discovered; when exposed to brilliant illumination, for example, certain organisms exhibit a severe disruption in respiration. Many animals live their active life in darkness, taking refuge and hiding during the lighter period of the day.

In a word, the role of light in the life of the ocean is enormous.

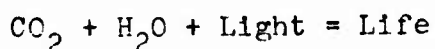

As it permeates the mass of the sea, sunlight activates what is perhaps nature's most amazing and most advanced mechanism - the mechanism whereby inorganic matter (carbon dioxide and water) is converted into an organic compound - carbohydrate. This process, whereby a plant, using light as a source of energy for the synthesis of various substances in the cell, enters into a redox reaction with CO_2 and H_2O is known as **photosynthesis**. The sum final result of this process can be represented by the following equation:

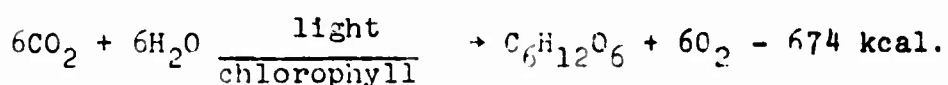

The result of this reaction is the origination of carbohydrates, ensuring plant growth and the release into the surrounding atmosphere of free oxygen.

The seas and oceans are the habitat of numerous algae which are capable of photosynthesis. Certain of these, the largest, live a sedentary way of life in the coastal strip of the ocean, but

the main mass of marine vegetation is not comprised of these bottom-dwelling seaweeds. The chief suppliers of food in the sea are the plankton algae, minute single-cell (or colony) plants which live their entire life within the mass of the water. Their morphological structure and specific weight, which is close to the specific weight of sea water, enables them to "hover" within the sea. Requiring light, they are found only in a shallow surface layer, to a depth of 100, rarely 200 m, where there is sufficient radiant energy to support photosynthesis.

A striking picture of the photosynthesis process, illustrating its extraordinary importance to all living matter, has been drawn by the great Russian scientist K. A. Timiryazev: "Somewhere, some time there once fell to earth a ray of the Sun, but it did not fall on sterile soil. It fell on the green blade of a wheat stalk, or, more precisely, on a chlorophyll grain. On striking this grain it was extinguished, it ceased to be light, but it did not disappear. It was merely expended in internal work, cutting and tearing the bond between the particles of carbon and oxygen combined in the carbonic acid. The released carbon, combining with water, formed starch. This starch, having transformed itself into soluble sugar, after long wanderings through the plant was finally deposited in the grain in the form either of starch or of gluten. In either form it became part of the bread that serves us as food. It was converted into our muscles and into our nerves¹."

Naturally, more specific information regarding the mechanism of photosynthesis has been acquired in the course of subsequent research. For example, it has been demonstrated that solar energy is expended in the decomposition of water and not carbonic acid.

¹K. A. Timiryazev. Solntse, zhizn' i khlorofill /Sun, Life, and Chlorophyll, Vol. 1, M., Sel'khozgiz, 1948.

But what happens under the action of light in the waters of the World Ocean? Exactly as on the dry land, solar energy penetrating into the sea is absorbed and exploited by plant life. By virtue of this energy, restored organic compounds are formed from oxidized inorganic compounds. The energy stored in these compounds covers all the energy expenditures of the sea-dwelling organisms during their movement, multiplication, biochemical metabolism, etc.. A transfer of the energy appropriated by these plants even occurs when one organism is consumed by another.

The ultimate food source for all the animals are the organic compounds which have accumulated in the body of the algae during the photosynthesis process. This storage of organic compounds leading to the growth of algae is referred to as the primary production of the ocean. As photosynthesis progresses, there ensues in the cell the photochemical splitting of the water molecule into hydroxyl and hydrogen ions. The hydrogen joins the carbonic acid and forms carbohydrates. Following this, the cell extracts from the water nitrogen, phosphorus, potassium, calcium, magnesium, sulfur, and the like. The albumins and other biochemical compounds are formed. An interesting point here is that all the processes, except for the photodissociation of water, are dark processes - that is, they do not require the additional absorption of light energy. The time span of the dark reactions is many times longer than that of the light reactions. Under conditions of an adequate supply of biogenic elements and good illumination, the sum speed of the primary production process is ultimately determined by the dark biochemical reactions. If there is little light, the photochemical (light) reactions are determinant and limit the overall rate of photosynthesis.

The absorption of solar energy by plants is effected with the help of pigments, that is, catalytically active colored compounds present in the algae. Each of the pigments absorbs

light in specific segments of the spectrum which are peculiar to it. Fundamental among these pigments is chlorophyll a, which is present in all photosynthesizing plants without exception. Chlorophyll molecules make excellent sunlight "traps." Their primary function, however, is the photodissociation of the water molecules. The most marked absorption peaks of chlorophyll a are found in the spectral regions of 420-430 and 670-680 nm. On the other hand, these emission regions are subject to considerable sea-water absorption, and therefore algae present a complex pigment system which is receptive also to radiation in other portions of the visible spectrum as well. Additional pigments absorb energy in spectral segments inaccessible to chlorophyll a and transfer this energy to it. The coloring of a given water plant (alga) depends on its set of pigments. Algae coloring is an inherited attribute and facilitates the spread of these plants at specific depths.

An important property of the pigment system is its capability for chromatic adaptation, that is, the ability to change rapidly and conform with the diurnal and vertical variations in the spectral composition of the light penetrating the water.

During the process of phytoplankton photosynthesis only a very insignificant portion of the light energy striking the surface of the World Ocean is actually used - an average of 0.04% of that which enters the water. In the most productive regions of the sea the efficiency of photosynthesis reaches about 0.35%, while in those areas that are poor in marine life it may be no more than 0.02%. The remaining solar radiation is absorbed by the mass of water.

As we know, illuminance decreases exponentially as a function of depth. This is likewise the nature of the attenuation of the intensity of photosynthesis with depth. This occurs until those levels at which the light reactions of photosynthesis begin to

limit its rate. Conversely, in the subsurface strata of the sea the excess of light suppresses the photosynthesis process. The sole exception are the near-polar regions where the quantity of light energy incident to the sea surface is insufficient to suppress photosynthesis.

The optimal value of light energy for photosynthesis is not the same in different biogeographic regions: for the tropic zone it is 60-85 cal/cm²; for the temperate latitudes, 15-20 cal/cm² per day. The minimum illumination intensity at which photosynthesis is possible at all is very low. Numerous species of marine plant life of the deep-water variety develop under conditions where the illuminance amounts to 10⁻⁵-10⁻⁷ of the sunlight striking the surface, which in terms of intensity is close to the illuminance created by the light of the moon.

Thus, the intensity of the light energy at different depths of the sea, along with its diurnal and seasonal variations, plays a major role in the primary production of ocean and sea waters.

An important parameter which characterizes the efficiency with which light energy is transformed into chemical energy is the quantum yield of the photosynthesis ϕ . This factor can be estimated by the number of synthesized carbon molecules with the absorption of a single quantum of light, that is

$$\phi = \frac{\text{number of } C_6H_{12}O_6 \text{ molecules}}{\text{number of absorbed quanta}} .$$

The photosynthesis quantum yield is less than one, and for this reason it is more convenient to employ the reciprocal quantity ($1/\phi = n$), which is called the quantum consumption and indicates how many light quanta are consumed in the synthesizing of one molecule of carbon $C_6H_{12}O_6$ - hexose.

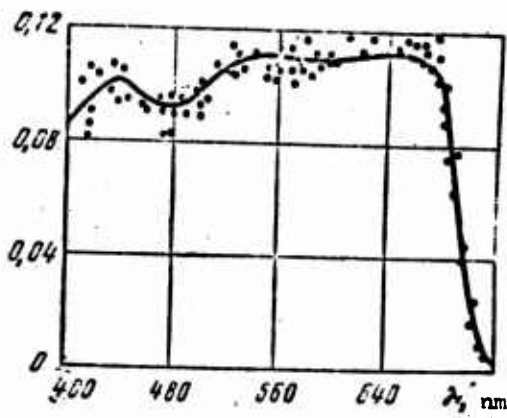

Fig. 66. Spectral dependence of the photosynthesis quantum yield.

From the graph presented as Fig. 66 it is clear that the photosynthesis quantum yield is not identical over the entire range of the visible spectrum. Under the most ideal conditions the yield does not exceed 0.12, that is, approximately 8 light quanta ($n = 1/0.12$) are required for the synthesis of a single hexose molecule. However, this figure is not constant and fluctuates within rather wide limits determined by the entire complex of conditions accompanying the photosynthesis process. Under conditions less favorable than during experimentation (insufficiency of nutritives, light, etc.) the quantum yield falls off.

Generally speaking, the problem of determining the dependence of primary production in the oceans on the conditions of underwater illumination is an extraordinarily difficult one. There is still a great deal that is unclear in the intricate process whereby the radiant energy of the Sun affects the phytoplankton of the sea. The nature of the reaction of the living cell of algae to radiation of various wavelengths, the manner of the pigment system's adaptation as a function of illumination conditions, and the like -- all these questions fall primarily within the competence area of scientists engaged in the study of plant physiology. As one of the branches of physical oceanology, hydrooptics has a somewhat special role within this array of problems.

In the investigation of light energy propagating in the sea and its effect on the photosynthesis of marine plant life there is one aspect of paramount importance. The fact is that as part of the program of biological research hydrooptical measurements are being conducted virtually everywhere in the World Ocean by scientists of different nations. In their investigations these specialists make use of energy meters of the most varied design and employ a variety of methods for the calculation both of the sum energy and its spectral composition. As a consequence of this diversity of approach, the resultant data in a very real sense resist collation, and this in turn makes it more difficult for scientists to arrive at a clear understanding of the degree to which the process of primary production depends on illumination intensity conditions on an oceanwide scale.

This need for standardizing the conduct of light measurements at and in the sea has led, under the auspices of UNESCO, the Scientific Committee on Oceanographic Research (SCOR) and the International Association of Physical Oceanography (IAPO), to the creation of a Working Group on Photosynthetic Radiation in the Sea. This group includes primary production specialists G. Gitts (Australia), E. Stiemens-Nilsson (Denmark), Y. Saijo (Japan), J. Steele (Scotland), along with the marine optics experts N. Jerlov (Sweden), A. A. Ivanoff (France), Yu. Ye. Ochakovskiy (USSR), and J. Tyler (US)¹.

The mission of this group is to provide answers to two fundamental questions: in the first place, what light energy measurements should be conducted at sea to reveal the relationships existing between the process of photosynthesis and the light in

¹Translator's Note - In almost all cases the latinized spelling of these names represents only an educated guess based on the Russian spelling.

the sea, and, in the second place, what kind of equipment is capable of ensuring the required accuracy and comparability of measurements.

The first conference was held in Moscow in October of 1964. Quite understandably, the questions on the agenda aroused fairly heated discussion. The group chairman, J. Tyler, voiced the belief that the instrument in question should be based on a radiation receiver having the same spectral sensitivity as the living cell of the phytoplankton. Tyler's position was violently opposed by the biologists. They maintained that to design the instrument according to this principle was impossible for many reasons. First and foremost, the diversity of species among plankton organisms is so great and their spectral sensitivity to radiation is so varied that the selection of any one averaged curve which would satisfy all situations would be simply unrealistic. In addition, the reaction of plankton to light does not remain constant by virtue of the plankton's capacity for light and chromatic adaptation, there being therefore the further need to make allowance for the inertial character of these adaptational processes.

After extended discussion a decision was adopted binding the hydrooptical specialists to develop an instrument capable of measuring with up to 10% accuracy the sum radiant energy propagating from the sea's surface to its depths in the 350-700-nm band. This meter was to be simple to handle and convenient to use in large-scale studies. In addition to the submersible sensor, the device was to be equipped with a similar radiation receiver for radiation readings in deck incubators where the illuminance conditions prevalent at different depths might be simulated. Moreover, the instrument envisioned was to be able to sum the energy during the exposure time of the sample vials - no simple task. However, perhaps the most difficult feature to achieve was the requirement that the instrument's radiation receiver be nonselective in the

350-700-nm interval, and also that it not react to emission outside this band - that is, that its measurements of sea-penetrating radiant energy be limited precisely to this region of the spectrum.

Before reaching a final decision regarding the creation of any new instrument, it was necessary to ascertain whether existing equipment might not be used for direct radiation measurements, along also with one of the indirect methods for the computation of the energy values - the optical classification scheme for waters proposed by Jerlov. In effect, provided one knows the law governing the attenuation of radiant energy in different portions of the spectrum in given waters, it is sufficient to measure the energy incident to the sea's surface and its attenuation in water within one narrow spectral segment in order, using Jerlov's curves, to compute the sum energy at the required depth. For this purpose, a standard-type pyranometer must be installed on the deck, with the measurement of the vertical attenuation index entrusted to a primitive photometer with a selenium photocell covered by a narrow-band color filter. At the Hydrooptics Laboratory of the Institute of Oceanology of the Academy of Sciences of the USSR methodological investigations had been conducted which indicated that in the transparent waters of the open sea the optical classification method is wholly applicable, although it is somewhat less accurate in the more turbid waters near the shore.

And so four years went by. In May of 1968 the hydrooptical members of the Working Group met in San Diego to compare different instruments for the measurement of photosynthetically active radiation (PAR) in the sea. Simultaneously, the Australian hydrobiologist Gitts conducted primary production measurements, using a deck incubator of his own design. The tests were conducted in California Bay. A combination of calm weather, cloudless skies, and high suns provided excellent working conditions. The measurements were taken with devices which differed in design and operating principle.

The Americans Tyler and Smith measured the spectral energy distribution at different depths using a submersible spectroradiometer. This instrument provided highly accurate spectral curves since its resolution was only 5 nm. The French hydrooptical specialists Ivanoff and Beauair made use of a similar device. In addition, they tested a high-sensitivity underwater pyranometer and a narrow-band lux-meter. Soviet specialists Ochakovskiy and Suslyayev employed an underwater pyranometer, a narrow-band lux-meter, and the VARIPO device.

Of particular interest was Jerlov's meter, for which he had coined the designation "quantometer." In this instrument the receiver is a selenium photoelectric cell, different surface segments of which are shielded by different color filters. According to Jerlov, this design renders the radiation receiver non-selective in the PAR band. Regrettably, Jerlov himself was unable to participate in the tests, and his instrument was demonstrated by two of his colleagues, K. Nugard and G. Kullenberg.

At the present time, with the test findings still in the analysis stage, it is premature to arrive at any judgements regarding the results achieved. It is clear, however, that this project represents merely one of the first steps in the search for an optimum instrument configuration to provide the light measurements so urgently needed by marine biologists.

An interesting piece of equipment for the analysis of photosynthetically active radiation has been designed by the Polish scientist Jerzy Dera. His device, which rides the surface in the manner of a float, sums the amount of energy striking the surface of the sea in the course of an entire day.

The point to be remembered is that the "light and photosynthesis" problem remains one of the paramount problems both of marine optics and marine biology. The ocean is the food supply source

of the future, and its abundance is mainly determined by primary production. Recently Soviet scientists O. I. Koblents-Mishke, V. V. Volkovinskiy, and Yu. G. Kabanova made an approximate estimation of the primary production of the World Ocean. They calculated that in a year's time marine plant life (algae) convert some 15-20 billion tons of carbon from the inorganic to the organic state. In other word, in a year algae account for the accumulation of 600-800 billion tons of raw biomass.

An additional factor to consider here is the fact that thus far the biological resources of the sea have not been subject to the regulatory of man. At a later date, when human beings learn to cultivate the seas and oceans, their productivity will unquestionably increase even further.

The Effect of Light on the Vital Activity of Marine Organisms

There are many phenomena in nature which still defy explanation. This is also true of the vertical migrations of zooplankton. What essentially is involved here? It was long ago noted that within the 24-hour period certain minute marine animals shift their location in the mass of water - at night they rise closer to the surface, descending to lower depth levels by day. The small plankton prawn (*Calanus finmarchicus*) travels some 500 m in a day's time, while the daily peregrinations of certain larger plankton organisms encompass layers of as much as 800-1000 m. The average speed of locomotion for these different organisms ranges from 0.5 to 3 meters per minute. A curious point is that during their vertical travels these animals traverse watery strata of differing temperature; on occasion the temperature discrepancy between layers may be around 10°. At the same time, considerably smaller temperature differentials pose an insuperable barrier to the horizontal distribution of these same organic species, thereby circumscribing their geographical proliferation.

There is not yet any consensus among hydrobiologists as to the cause of these daily migrations. In the view of some, the organisms gradually developed these vertical displacements as a kind of defense mechanism against the attack of predators. Most biologists, however, are convinced that the cause of the migrations lies in the diurnal variations of the natural illuminance. Further biological and biophysical research will hopefully yield the final answer to the problem of these twenty-four-hour vertical migrations.

In our own view, those hydrobiologists who hold that it is changes in illumination intensity that are responsible for the vertical movement of organisms on a daily basis are closer to the truth. This is also supported by the findings of T. S. Petip, who on 30 June 1954 observed the behavior of zooplankton in Sevastopol Bay during a solar eclipse. The Sun's disk on that occasion was 92% obscured, thanks to which, according to Petip's calculations, there was a 17-fold reduction in the normal daytime illumination of the sea's surface. Zooplankton catches throughout the entire mass of water indicated that many zooplankton species were rising from the depths to the upper 0-5-m layer of the water. Following the conclusion of the eclipse, when normal sea-surface illuminance was restored, the main mass of the zooplankton descended very rapidly to the deeper-lying strata.

In this instance the connection between the change in illuminance and the vertical migrations of the zooplankton is absolutely obvious. But what will happen if there is no change in illumination intensity over an extended period of time - say, three or four weeks? Will the zooplankton now also follow the customary rhythm of vertical migrations? Such a situation was investigated in the Arctic by V. G. Bogorov during the height of the polar summer, when the Sun remains above the horizon around the clock.

Bogorov conducted observations into the behavior of the aforementioned zooplankton prawn (*Calanus finmarchicus*) off the coasts of Novaya Zemlya. He reported that during the polar day the *Calanus* kept to the same depth level, revealing no vertical movements, but that in the fall, during the period of alternating day and night, the same organism carried out its diurnal migrations. Bogorov made no recording of the above-water illumination intensity; therefore, we can only approximately estimate its value and diurnal variations, using O. A. Sokolov's figures, which were obtained for the same latitude but a different longitude. During the polar day the illuminance value varies from 500 to 1800 lux, giving rise to a change of from 0.5 to 4 lux in the underwater illuminance at the constant level at which the *Calanus* gather. In all likelihood, these light intensity variations are not sensed by the organism.

Concurrently, there are data which suggest that specific zooplankton species react to more subtle changes in lighting. The English biologist Moore has observed, for example, how when the Moon appears suddenly in the sky, it causes zooplankton organisms to descend from the uppermost surface level to a certain depth... and this even though the illuminance created by the Moon on the sea surface is only 0.5 lux¹.

The examples cited, it would seem, provide convincing evidence of the relationship between the regular up-and-down diurnal movement of many plankton animals - their vertical migrations - and the change in the amount of light penetrating into the body of sea water. Moreover, investigators have noted that each animal,

¹According to measurements made by the German researcher G. Luneburg, at a depth of 25 cm the illumination intensity created by moonlight equals 0.011 lux, and at the 3-meter level 0.002 lux. During the measurement cycle the sea-surface illuminance caused by the Moon fluctuated within 0.1-0.3 lux.

as it ascends or descends, attempts to keep to locations with identical illumination. This was particularly evident during studies of sound-scattering layers - local clusters of large plankton organisms and fish detectable by means of hydroacoustical devices such as echo-sounding equipment. Such sound-scattering layers are rarely formed from animals of only one species. Normally the upper section reveals a concentration of Euphausiidae - shrimp-like animals. These creatures have enormous black eyes (whence their local Russian name: "chernoglazki"); their body (1-3 cm) is transparent with tiny red spots. The lower tiers of the sound-scattering layer are occupied by minute fish.

In the summer of 1954 the American biophysicists E. Camm and B. Bowden conducted extensive investigations of sound-scattering layers in the Pacific Ocean off the California coast. Recordings of layer displacement were combined with measurements of underwater illuminance by means of a bathyphotometer equipped with a highly sensitive photomultiplier. Before dawn on the 2nd of July the bathyphotometer was lowered to the depth of the upper plankton section of the sound-scattering layer (the illuminance was $6.3 \cdot 10^{-4}$ lux). Shortly thereafter the layer began to descend. Simultaneous uninterrupted recordings of the illuminance revealed that it remained constant at $6.3 \cdot 10^{-4}$ lux. The layer ceased its downward movement at 243 m, with the bathyphotometer continuing to indicate $6.3 \cdot 10^{-4}$ lux. The evening ascent went much the same way, that is, the upper portion of the sound-scattering layer consistently recorded the same illumination intensity value (Fig. 67). True, this value was not the same as the illuminance in descent, but noticeably exceeded it ($7.1 \cdot 10^{-3}$ lux). The reason for this is to be found in the fact that on the moonless night before the descent (the night of July 1) the animals adapted well and, consequently, were less sensitive to the low illumination levels than in the daytime period before the ascent (the evening of July 2).

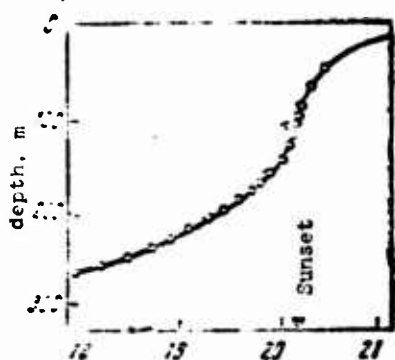

Fig. 67. Change in the depth of occurrence of a sound-scattering layer during the evening ascent (circles) and the variation of the illumination intensity (solid line).

These examples show that in all likelihood even the rate of plankton-organism migration depends on the rate of change in underwater illuminance. The majority of investigators have centered their attention on the nexus between vertical zooplankton migrations and changes in sunlight illuminance. Only a very few have studied the effect of moonlight on such migrations. The Japanese oceanographer Uda maintains that the Moon affects the position of sound-scattering layers. With lunar illumination these layers recede from the surface of the sea, resulting in poor catches of squids and many fish.

The Coloring of Marine Organisms

Biologists of one of the oceanographic expeditions on the vessel "Michael Sars" turned their attention to the coloring of the fish and animals in the Sargasso Sea. The upper stratum of the water, abundantly illuminated by the sunlight, is populated by blue flying fish and medusalike Siphonophora. Here also dwell the totally colorless glassy larvae of the eel and clumps of uncolored jelly - the medusa or jellyfish. At times these fish are even invisible in a bucket of sea water. Their ideal coalescence with their environment is primarily explained by the fact that the indices of refraction of the larvae and medusas are

close to the refractive index of water, so that light rays are not reflected and do not change their direction when passing through their bodies. Additionally, the degree of light absorption by these organisms is also very low.

Fish in the upper layer of the sea generally have a light belly and a darker back. From above, the back is difficult to discern against the dark depths of the water, while, from below, the fish's light-colored belly tends to blend in with the sunlit surface of the sea. Fish with brown backs can be found at a depth of 300 m. This is understandable: there is less light here.

The larvae of the surface-swimming Siphonophora - Physalia - inhabit the area from 300 to 400 m in depth and are not blue-colored, as are the adult forms, but bright red. In the surrounding blue-violet gloom this color is perceived as virtually black. The color of the Calanus, which descends in the daytime to 300-500 m, is likewise red. This color is complementary to the light penetrating to the depth in question.

Below 500 m only black fish and red prawns were caught from the deck of the "Michael Sars."

Toward the end of the thirties the French biologist Bertin, in a report to the Biogeographical Society declared: "Evidently, a depth of 7000 m should be regarded as the limit for the propagation of living organisms, with the exception of bacteria." In 1949, however, a Soviet expedition on the "Vityaz'," operating over the Kuril Trench, discovered different life forms below the "Bertin life boundary." The fish Careproctus amblistomopsis was caught at a depth of 7230 m.

Extensive biological studies of the ultimate depths of the ocean were carried out by a Danish expedition on the "Galatea" in 1950-1952. Of particular significance, however, to the discovery

of life in the deep-water trenches and depressions of the oceans have been the Soviet "Vityaz'" expeditions. In January of 1958 the biologists of this team succeeded in exploring, with a deep-water dredge, the Tonga Depression to a depth of 10,700 m. In the net were captured animals belonging to a variety of zoological groups. What was the coloring of these unfathomable, unilluminated depths? The majority displayed a faint grayish-yellow coloring, with the remainder not colored at all. The fact is, of course, that coloring here has no protective significance, such as it does nearer the surface or at a depth of a few hundred meters.

Many marine animals have a capacity for active camouflage - that is, homochromia. Such creatures can assume a color in accordance with their environment, copying with a fair degree of accuracy, through pigmentation, the spectral reflection curve of the background. This is possible because of an amazing "spectrophotometric" feature in the vision of fish and animals, that is, their ability to perceive in the light spectrum an energy distribution which man is able to discern only with the aid of a special instrument - a spectrophotometer. Wide publicity has been given to tests with a flounder which was placed in an aquarium against a blue, red, green, and violet background and on each occasion changed its coloring accordingly. Not only that, but the flounder copied not merely the color but the pattern of the background.

Once a fish or animal loses its sight it also loses its camouflage ability. N. I. Tarasov has reported catching a flounder at Sivash with skin drawn tightly over its eyes. This specimen was black in color and stood out conspicuously from among the sighted flounders whose green coloring matched the shade of the seaweed.

A remarkably skillful master of pigmentation camouflage is the prawn *Hippolite varians*. This small creature, no more than

2.5 cm in length, attaches itself to seaweed and assumes its color. The prawn is capable of rapidly changing its color to green, brown, and red, which happen to be precisely the colors of the group of marine algae inhabiting the shallow zone of the ocean. In fact, they are even so named: green, brown, and red algae.

The regularity in the depth distribution of these algae has long been a subject of inquiry. Table 2 indicates the number of types for the different algae groups found in Kiel Bay at different depths.

This tiered arrangement holds true in other seas as well. As indicated by investigations, it is related to the varying depth-specific spectral composition of the sunlight. The green algae inhabit the uppermost level where there is still red light to be actively absorbed by the chlorophyll a. In the same manner as ground plants, they make the best use for photosynthetic activity of the blue light and also of radiation at a wavelength of 640-650 nm. In the red and brown algae maximum assimilation occurs in the blue and green regions of the spectrum.

Table 2

Depth, m	Types of algae		
	green	brown	red
0—2	30	11	4
7—8	10	15	18
8—12	3	9	11
18—25	—	5	7

For adaptation to one or another spectral light composition at specific depths, algae (just as many other plants, for that matter) develop a pigment-plastid system which ensures the most

efficient utilization of the light. The green algae contain a definite amount of chlorophylls a and b. Chlorophyll a provides the best absorption of red light, and chlorophyll b of light in the shortwave region of the spectrum. The pigment-plastid ratio changes as a function of the prevailing light in the underwater illumination mix, and there is a simultaneous change in the coloring of the algae themselves. The latter take on a complementary color with respect to the light which is best used by the plant for the purpose of photosynthesis.

The prawn *Hippolite varians* acquires a different color, in accordance with the algae color at different depths, only by day; at night, regardless of its daytime color, it assumes a beautiful transparent blue shade.

This then is nature's solution to the baffling problem of camouflage adapted to a changeable background as affected by varying conditions of natural illumination.

The Sea Lives — The Sea Glows

In the summer of 1968 the "Chernomor" /Black Sea/ underwater laboratory was set up on the floor of Golubaya /Blue/ Bay near the city of Novorossiysk. Several crews, operating in shifts, carried out underwater observations according to a variety of programs. The hydrooptical program, specifically, called for the oceanauts to carry out night excursions from their underwater laboratory. As the men moved through the black water bluish sparks flashed around them. Any chance rotary motion of the arm resulted in a glowing circle. The source of these fairly brilliant flashes was found to be tiny single-cell flagellate organisms - night-glowers (*Noctiluca miliaris*). They measure 0.2-2 mm in size.

Sea-glow is also the work, however, of many other small inhabitants of the water - planktonic prawns, shrimps, and

mollusks. But the prime contributor to sea-glow is above all the plankton. There is a hypothesis to the effect that Columbus mistook the flickering of large clusters of some kind of tropical Polychaeta for light signals being sent from an unknown shore. He described these signals as being like the light of an alternately raised and lowered candle. Columbus saw these mysterious flashes at about 10:00 pm on the 12th of October 1492. . Historians who have studied the ship's records of the "Santa Maria" have concluded that during the observations of the "light signals" the Genoan was some 80-85 miles from Watling Island and, thus, could not at this distance have made out the light of a candle.

At the same time, natural scientists have drawn attention to the fact that in these localities, during the final phase of the Moon, glowworms regularly rise to the surface of the sea. The Moon happened also to be in its final quarter on 12 October 1492 - what Columbus saw was probably the glow of these worms.

That these flashes are quite intense and can be seen at considerable distances is demonstrated by the following example. No more than six miniature euphausiid prawns placed in a glass jar emit enough light for a man with good vision to read a newspaper by.

Organic phosphorescence may be intracellular or extracellular. The first kind is encountered with greater frequency and is proper to masses of single-cell organisms and bacteria. In the higher crustaceans and fish it is concentrated in special organs - photophores. Extracellular phosphorescence is found, for example, in certain squid and shrimp which eject a glowing mucous in the manner of a screen.

At the present time biochemists have established that phosphorescence is mainly brought about through the oxidation of luciferase (a substance similar to vitamin K) by luciferin (a

protein with high molecular weight). Both these substances are contained in special cells of the organisms. The physical nature of the phenomenon is also understood, the name for it being bioluminescence or living cold light. In bioluminescence the energy of the chemical reaction causing the glow is almost totally converted into light with no heat losses. Luminescence efficiency exceeds 90%.

Earlier theories sought to explain sea-glow by invoking the gleam of phosphorous in the sea (whence the concept "phosphorescence of the sea"). There was also a hypothesis to the effect that the water would release the sunlight stored up during the daylight hours of the day. According to still another, "mechanical," viewpoint the light was emitted by salt molecules rubbing against water molecules.

A mechanical effect by certain stimuli is required to trigger the luminescence of these organisms. Such stimuli may include the motion of the water, friction against air bubbles, and contact with alien, especially moving, objects. Only in the case of fish and certain higher crustaceans and mollusks is luminescence caused by neuro-hormonal activity. It is also worthwhile noting that the light of bacteria alone is independent of external stimulation.

Thus, the glowing of the sea is a manifestation of bioluminescence representing the aggregate of the bioluminescent flashes of marine organisms. Most of the time such bioluminescent signals are very weak and their detection requires extremely sensitive receivers of light energy - photoelectron multipliers. Even at very close range the human eye is barely able to perceive these signals. On the other hand, there are cases when marine phosphorescence may be clearly visible even at considerable distances.

In an article by an Italian researcher L. Cappuro "Oceanography From Space" (Bolletino di Geofisica Teorica ed Applicata, 9, No. 33, 1967), quoting the US astronaut S. Carpenter, the assertion is made that in tropical waters the glowing wake of a large vessel may be seen from an altitude of 100-200 km.

Luminescence increases if the sea surface is irradiated with light pulses. The American researcher Nashiba, using a xenon pulse lamp, discovered that as a result of the optical stimulation of the glowing organisms the level of bioluminescence increased a thousand times. Even visual observations have provided some idea of the enormous scale of this phenomenon, which embraces vast bodies of water and virtually all latitudes. During the voyage of the ship "Beagle," while off the coasts of South America, Charles Darwin wrote: "...a fresh breeze was blowing and the entire surface of the sea, which by day was covered with foam, was now gleaming with a white light. Ahead of the prow two waves rose up as from liquid phosphorous, and behind it stretched a milky wake...¹." What Darwin was observing was the phosphorescence of the sea in tropical latitudes. The following is an entry written by K. S. Badigin, Captain of the icebreaker "Sedov," while adrift in the central Arctic Ocean: "A south wind is raising waves in the clear water between the ice. The waves are licking our floe. When they recede, a greenish phosphorescent glow is left behind on the ice...²."

Occasionally sea-glow occurs in the form of strange strips or circles. This is so-called figured luminescence. Seamen of merchant vessels who have observed it recount that they were gripped by a feeling of fear as the glistening bands and wheels moved

¹Ch. Darwin /Darwin/. Sobr. soch. /Collected Works/, Vol. 1, SBp. 1898 (in Russian).

²K. S. Badigin. Vo l'dakh Arktiki /Amid The Ice Of The Arctic/. M.-L., Izd-vo Glavsevmorputi, 1951.

over the surface of the night sea. One of the authors had the opportunity, near Hodeida in the Red Sea, of observing four phosphorescent strips connected at a single point and somewhat reminiscent of faint searchlight rays slowly turning in a counterclockwise direction. This observation had to be broken off when the Moon emerged from behind the clouds which had hitherto been obscuring it.

An explanation for figured luminescence was recently found by the German oceanologist K. Kalle. After analyzing more than two thousand observations of this kind he concluded that the cause of figured luminescence lies in the flashing, near the sea surface, of tiny organisms startled by the shock waves which arise with the shifts and movement of layers on the ocean floor. These shock waves are transmitted into the mass of the water, so that on the surface, where the luminescent organisms gather, the result is a kind of interference pattern. If the seismic sources on the sea bed change their position, this pattern is activated.

Strictly speaking, sea-glow is understood to mean the increased brightness of the sea surface brought about by the light of marine organisms congregating in the near-surface layer of the water. However, bioluminescence has also been observed actually within the sea itself. We have already mentioned the experiences of the oceanauts of the "Chernomor." From the underwater laboratory "Carribean 1," set up in July of 1966 on the floor of Rincón-de-Guanaba Bay not far from Havana, oceanauts were also able to observe bioluminescence. Writing in his diary, Miguel Montanes noted: "I observed the life of the sea by night over an extended period. Countless small flashes of fire were springing up all over. Stellar and lunar illumination cannot penetrate a 20-meter layer of water. The sole source of natural light at these depths at night is the plankton mass. From time to time some unknown phosphorescent fish would swim by in this spectral light...¹."

¹A. A. Chernov. Gomo akvatikus /Homo Aquaticus/. "Molodaya gvardiya," 1968.

To date, however, underwater laboratories have been put into service only at relatively shallow depths. It is true, nevertheless, that even at considerably greater depths investigators have seen luminescent animals with their own eyes. In a pioneer project, William Beebe, taking a bathyscaphe to a depth of 923 m, reported on the presence of glowing animal life. This researcher even took a number of unique photographs, filming the luminescent creatures in their own natural light.

Professor August Piccard reached the floor of the Mediterranean in the bathyscaphe "Triest," attaining a depth of 1080 m. "We switch off the light and all around there is total darkness. I approach the porthole: some kind of gleaming point, like a shooting star, cuts across my field of vision. Living matter! Is it a plant or an animal? In this kind of darkness no true plants could exist. We frequently encounter phosphorescent animals, traveling along sometimes in groups and sometimes alone... and then we again plunge into the impenetrable gloom.¹"

The genuine revolution in the study of bioluminescence began, however, only after scientists began to measure it using bathyphotometers. These instruments, equipped with particularly sensitive vacuum-type photomultipliers, record the faintest flux of light, down to even a few quanta per second. Bathyphotometers made their first appearance only ten or twelve years ago, but since then they have been employed to carry out extensive investigations in the Atlantic, Pacific, and Indian oceans to depths of 2000 m. These studies were summarized at the Second International Congress of Oceanography in Moscow in 1966: bioluminescence is characteristic throughout the entire volume of the ocean and is unquestionably a permanently operative factor in marine optics and in the ecology of marine organisms.

¹A. Piccard. Ibidem.

The first Soviet instrumentation investigations of bioluminescence were conducted under the supervision of Professor I. I. Gitel'zon in the Pacific Ocean in 1961 from the scientific-research vessel "Vityaz'." Gitel'zon noted that on bathyphotogram recordings the bioluminescent flashes, which show up in the form of pulses, form a dense flow that often merges into a single whole. In this way, bioluminescence should be regarded not as some rare phenomenon or occurrence sporadically recorded by a bathyphotometer suspended somewhere under water, but as information regarding unceasing biological processes in the sea.

The form of the light signal of individual organisms has also been studied under laboratory conditions using flow-through photometric apparatus. Investigators have noted a nonuniform distribution in the depth of the bioluminescent flashes, with the maximum number of flashes observed at depths of 50-100 m (several hundred per minute). As was later discovered, it is precisely at these depths in the surveyed region of the Pacific that clusters of luminescent plankton forms are encountered. At certain depth levels only a few flashes (less than ten per minute) were recorded, or none at all.

Thus, at the very beginning of instrumental bioluminescence research the massive character and significance of this phenomenon from the standpoint of marine optics became obvious. It is curious that the maximum bioluminescent signals recorded by Gitel'zon amount to $9.6 \cdot 10^{-2}$ microwatt/cm², which exceeds the maximum illuminance created by a full Moon on the surface of the sea ($4.5 \cdot 10^{-2}$ microwatt/cm²). It naturally follows, therefore, that in the total illuminance balance for any level in a sea water mass, along with an estimation of astronomical light external with respect to the sea (Sun, Moon, stars), the sea's natural light - bioluminescence - must also be taken into account.

Gitel'zon distinguishes three light zones in the ocean:

- 1) 0-200 m - a zone of daytime solar and nighttime mixed (astronomical and bioluminescent) glow;
- 2) 200-700 m - a zone of daytime solar and nighttime bioluminescent glow;
- 3) below 700 m - a zone of bioluminescent glow alone.

Laboratory studies of the spectral composition of the light radiated by phosphorescent marine organisms indicate that their entire emission falls within the 400-700-nm band and is maximum in the 480-520-nm wavelength interval. The reader will recall that it is precisely in this spectral interval that one finds the maximum transmittance value for transparent ocean water. Naturally, therefore, the light signals emitted by these organisms pass easily through the volume of ocean water; and this is probably not a chance effect, but the result of a long evolutionary process in the animal world. We might also add that the light efficiency of bioluminescence is extraordinarily high.

Some idea of the light efficiency of bioluminescence may be obtained by comparing its spectral composition with the spectral sensitivity distribution of the receiver. In highly organized organisms the eyes function as the radiation receiver. However, the visual properties of the inhabitants of the sea have not yet been adequately studied, and one can only conjecture that the spectral sensitivity of their eyes is tuned to the emission of the Sun, that is, is close to the spectral sensitivity of the human eye.

By comparing the luminescence spectrum of a marine organism with its luminescence spectrum corrected for the visibility curve, we obtain the light efficiency of the radiation. The closer the maximum radiation to the apex of the visibility curve, the greater the light efficiency of the radiation. In certain fireflies whose radiation maximum (562 nm) is close to the visibility curve apex the light efficiency of radiation is 92%.

In this way, the light efficiency of bioluminescence far exceeds the efficiency of all known electrical and thermal sources of light.

The biological meaning of bioluminescence is still not entirely clear. In some organisms it performs a signal function, providing a means of communication between individuals of the same species. Other organisms employ their luminescence to attract their prey or frighten away predators. In a number of cases, bioluminescence appears to be used for illumination. Thus, in certain deep-water fish the light-bearing organs (photophores) are of very advanced design, possessing lenses, reflectors, and even colored filters. The biological significance of bacterial phosphorescence is altogether unclear.

In recent times there has been heightened interest in bioluminescence. From the point of view of bionics, bioluminescence represents an example of a lamp with an extremely high degree of light efficiency accompanied by very low energy expenditure. The study of bioluminescence has great practical importance.

Our account of the sea-glow phenomenon will probably be incomplete unless we make mention of one more effect. In the twenties of the present century the Indian scientist K. Ramanathan called attention to the faint greenish glow of sea water when irradiated by ultraviolet light. Careful analysis disclosed that this glow derives from the presence in the sea water of so-called fluorescent substances of organic and inorganic origin. The phenomenon of fluorescence, long familiar to physicists, consists in the ability of certain substances to glow, that is, to emit visible light when irradiated by ultraviolet light of shorter wavelength. This emission, moreover, ceases at once immediately following the discontinuance of the irradiation. In shallow inland seas fluorescence affects the visible color of the sea, giving it

an additional greenish cast. The fluorescent effect is particularly conspicuous in the coloration of the sea following a storm in the areas closer in toward the shore, this being related to the stirring up of the fluorescent particles contained in the fine silty deposits of the bottom. A curious point is that fluorescent substances are also present in petroleum. Recently, marine geologists, equipped with aqualungs and sources of ultraviolet radiation invisible to the eye (or, as the professionals say, "black light"), have been conducting intensive searches for oil outlets in the shelf region.

Ultraviolet lamps have also won favor with archeologists, who guide themselves by the characteristic greenish glow to detect the wrecks of ancient wooden ships, and even with criminologists. English illumination engineers maintain that because of the fluorescence of human skin it is more advisable to search for the bodies of drowning victims at night than by day. The specialists have shown that the range of detection of drowned persons, using ultraviolet lamp irradiation, is eight times greater at night than during the day.

We might also add that in more recent time fluorescent substances - rhodamine and fluorescein - have come into wide use in studies of turbulent diffusion in the ocean. These agents offer many advantages over nonfluorescent dyes. Specifically, they are completely harmless to man and to the inhabitants of the deep.

CONCLUSION

With every passing year the range of questions engaging the attention of hydrooptics grows larger. This expanded problem area will inevitably lead to new trends and new directions. Even today one of these new trends has already taken distinct form - optics of the night sea (nocturnal marine optics) - a scientific discipline which owes its origin in large measure to the rapidly evolving needs of marine biology.

The role of moonlight penetrating a body of water is still unclear. By examining the laws governing the propagation of such celestial light in the sea, nighttime marine optics will assuredly be of assistance in decyphering this scientific enigma.

The enticing effect of light has long been known to man. In Vietnam fishermen often bait their lines with the luminescent organs of the squid, which they have previously also snared through the use of light. The technique is to start a fire on the shore and then cast on the water a fishing line with a scrap of white cloth. Usually, it will not be long before a school of squid, attracted by the light, puts in an appearance, and one of their number - the most curious - seizes the cloth. The fishermen carefully pulls in the line and snatches his prey from the sea.

During the "Vityaz'" expeditions in the Pacific and Indian oceans, weather permitting, with the vessel at anchor for the night, the biologists would take the occasion to lower overboard high-intensity electric lamps. A variety of creatures would be attracted from the night ocean up into the circle of light - flying fish, anchovies, living-rocket-like squid, and many other inhabitants of the deep.

Why is it that a brilliant light piercing the underwater gloom will lure fish and marine animals? Several explanations

have been advanced. Nikanorov and Belyayeva, for example, explain the fact that fish and animals can be so lured by their exploratory reflex. In some countries, including our own, fishing by electric light is practiced on an industrial scale. Drawn by an underwater lamp arrangement, clusters of sprat are scooped up by a pump and spill onto the deck of the processing vessel in a silvery stream. The Cololabis saira of the Far East is also caught through the use of a high-power electric light source.

At the same time, however, fish are also known to exhibit a negative reaction to light. Light-shunning eels do their extensive traveling at nighttime only. A project has been devised calling for the stringing of a chain of electric lamps across one of the straits connecting the North Sea and the Baltic (the Little Belt). The idea is that the eels migrating from the Baltic, on encountering the luminous obstacle, would rush into a specially prepared narrow channel where they could be easily caught. Unfortunately, because of differences of opinion among the fishing interests concerned, it has not yet been possible to put this plan into actual practice.

Certain fish are taken with luminescent light - daylight lamps, as they are commonly called.

In all likelihood, optical investigations of bioluminescence will enable biophysicists and biochemists to develop new and more advanced sources of luminescent light, for any glowing substance is in effect a living miniaturized model of a chemical reactor with a very high light energy yield. For bionics - the science which studies the feasibility of technologically exploiting living nature's best achievements - it will also be interesting to study light as a means of spatial orientation. We have already discussed how certain species of marine animals use polarized light for navigational purposes. We might merely add that, to date, engineers

specializing in optical mechanics can only dream of a polarimeter capable of determining polarization parameters with the same accuracy as these animals.

The widening range of problems of concern to marine optics will inevitably result in the development of new and the improvement of old methods of oceanological research. Soviet hydrooptical specialists have devised a very promising method for rapidly measuring a number of optical characteristics from an overhead aircraft. Special optical equipment installed on the plane is used to determine a major parameter, namely, sea surface brightness.

Concurrently, marine optics is also becoming an underwater science, with the experts more and more frequently taking their investigations into the depths of the sea itself. In the summer of 1968 the "Chernomor" submarine laboratory was set up in Golubaya Bay near Gelendzhik. Five crews, working 5-to-6 day shifts each, conducted a program of observations from this base. On the upper deck they installed a device for the measurement of underwater illuminance, while in a special apparatus they installed another instrument, called a "hydros spider," to provide readings of the polarization and brightness of the natural light. This apparatus, consisting of a buoy with an instrumentation platform and an intricate array of metal lines, was secured to the sea bed some 20-25 m from the "Chernomor." The buoy was capable of submersion to any depth, in this way enabling the observers to measure optical characteristics from the surface to the bottom.

The "Chernomor" experiment was the first of its kind in marine optics and was a harbinger of the rich prospects held out by underwater laboratories for the conduct of precise and protracted underwater measurements. The fact is that to date the vast majority of hydrooptical readings have been taken from on board scientific-research ships subject, as a rule, to wave and ripple surface disturbance. Obviously, measurement precision under

these conditions is less satisfactory than from the rigidly secured "Chernomor" laboratory. Another factor of great importance is that, by temporarily leaving the lab, an oceanaut is free at any time to check the operation of the instrument packages.

In the summer of 1969 optical research with the "Chernomor" laboratory was conducted at greater depths. The scientific program was expanded and diversified.

Whenever optical quantum generators, or lasers, are mentioned in technical writing, a long list of their "credits" is almost always cited. In fact, lasers are employed in a very wide range of scientific and technological applications. They can be used in place of the surgeon's scalpel in delicate operations or of the welding torch in the fusion of metals, for observations of artificial earth satellites and in meteorology. The needle-sharp laser beam has also found extensive application in marine optics. Radio-waves, as we are aware, propagate poorly in the sea, and for a long time only acoustical methods were used for underwater communication. Until the invention of optical quantum generators optical communication was simply out of the question.

The effective range of the concentrated flow of light emitted by a laser in an air or, all the more, an airless medium extends to millions of kilometers. But what distances can the laser beam cover in water? US researchers have reported that because of the severe absorption of red light by water the effective range of a ruby laser with a pulse power of 210 W is no more than 50-60 m. The ruby laser is obviously unsuited for underwater communication. The situation changes, however, in the case of lasers operating in the more transparent region of the visible-light spectrum. According to data developed by a team of American specialists, the ray from a blue-green laser can travel 1200 m in an aqueous medium. This kind of laser, therefore, offers a genuine possibility of establishing effective underwater optical communications.

Laser radiation is being used today in the creation of extraordinarily sensitive hydrooptical instrumentation. In Jerlov's laboratory a device has been designed and successfully used for scattering measurements directly in the sea. The American optical expert Spielhaus, using a laboratory-type instrument in which the light source is a gaseous neon-argon laser, has conducted extensive readings of light scattering by sea water in the Atlantic and Indian oceans. Reports have been made of efforts to use special-purpose optical quantum generators as optical gyrocompasses.

Hydrooptics is one of the newest branches of oceanology. Over the last ten years it has made rapid advances. Actually it was not very long ago at all that all research in the area of marine optics could ultimately be reduced to observations of the so-called transparency of the water by means of the white disk and to sea color determination by the Forel-Ule scale. Naturally this information was inadequate to meet the growing needs of scientific and practical applications. This in turn led to the development of new methods and more advanced methods for the measurement of the sea's optical parameters. The continued need to solve a whole complex of urgent oceanological and hydrobiological problems, as well as tasks of a purely practical nature, will inevitably result in still further significant progress in this vital and fascinating branch of hydrophysics.