

AD-753 618

EXPLORATORY STUDY OF THE TURNING  
CHARACTERISTICS OF A COANDA-OPERATED  
JET-FLAP

James Houston Blakeney

Naval Postgraduate School  
Monterey, California

September 1972

DISTRIBUTED BY:

**NTIS**

National Technical Information Service  
U. S. DEPARTMENT OF COMMERCE  
5285 Port Royal Road, Springfield Va. 22151

AD 753618

# NAVAL POSTGRADUATE SCHOOL

Monterey, California



## THESIS

EXPLORATORY STUDY OF THE TURNING  
CHARACTERISTICS OF A  
COANDA-OPERATED JET-FLAP

by

James Houston Blakeney

Thesis Advisor:

Max F. Platzer

September 1972

Reproduced by  
NATIONAL TECHNICAL  
INFORMATION SERVICE  
U S Department of Commerce  
Springfield VA 22151

Approved for public release; distribution unlimited.

69

## DOCUMENT CONTROL DATA - R &amp; D

(Security classification of title, body of abstract and indexing annotation must be entered when the overall report is classified)

1. ORIGINATING ACTIVITY (Corporate author)		2a. REPORT SECURITY CLASSIFICATION	
Naval Postgraduate School Monterey, California 93940		Unclassified	
3. REPORT TITLE		2b. GROUP	
Exploratory Study of the Turning Characteristics of a Coanda-Operated Jet-Flap			
4. DESCRIPTIVE NOTES (Type of report and, inclusive dates)			
Master's Thesis; September 1972			
5. AUTHOR(S) (First name, middle initial, last name)			
James H. Blakeney			
6. REPORT DATE	7a. TOTAL NO. OF PAGES	7b. NO. OF REFS	
September 1972	70	49	
8a. CONTRACT OR GRANT NO.	8b. ORIGINATOR'S REPORT NUMBER(S)		
b. PROJECT NO.			
c.	9b. OTHER REPORT NO(S) (Any other numbers that may be assigned this report)		
d.			
10. DISTRIBUTION STATEMENT			
Approved for public release; distribution unlimited.			
11. SUPPLEMENTARY NOTES		12. SPONSORING MILITARY ACTIVITY	
		Naval Postgraduate School Monterey, California 93940	
13. ABSTRACT			
<p>An exploratory investigation of the jet deflection characteristics of a jet-flapped airfoil with Coanda deflection surfaces was performed. Velocity distribution and flow angle measurements were made with the jet-flap in static operation. Flow visualization tests were used to determine the turning characteristics in incompressible flow.</p>			

1a



Exploratory Study of the Turning Characteristics  
of  
a Coanda-Operated Jet-Flap

by

James Houston Blakeney  
Lieutenant, United States Navy  
B.S., United States Naval Academy, 1966

Submitted in partial fulfillment of the  
requirements for the degree of

MASTER OF SCIENCE IN AERONAUTICAL ENGINEERING

from the

NAVAL POSTGRADUATE SCHOOL  
September 1972

Author

James H. Blakeney

Approved by:

Miss F. T. Lester

Thesis Advisor

A. W. Bellog  
Chairman, Department of Aeronautical Engineering

Milton G. Clavel  
Academic Dean

## TABLE OF CONTENTS

I.	INTRODUCTION -----	9
	A. THE JET-FLAP -----	9
	B. THE JET-FLAP PRINCIPLE -----	12
	C. COANDA EFFECT -----	14
	D. OBJECTIVES OF THE PRESENT STUDY -----	16
II.	DESCRIPTION OF TEST APPARATUS -----	18
	A. NECESSARY SUPPORTING EQUIPMENT -----	19
	B. DETERMINATION OF PITOT TUBE POSITION -----	19
III.	TEST PROCEDURE -----	20
	A. STATIC TESTS (JET UNDEFLECTED) -----	20
	B. STATIC TESTS (JET DEFLECTED) -----	21
	C. WIND TUNNEL TESTS -----	22
	D. BALANCE TEST -----	24
IV.	DISCUSSION OF RESULTS -----	25
V.	CONCLUSIONS AND RECOMMENDATIONS -----	31
	BIBLIOGRAPHY -----	64
	INITIAL DISTRIBUTION LIST -----	68
	FORM DD 1473 -----	69

## LIST OF FIGURES

<u>Figure (s)</u>	<u>Title</u>	<u>Page</u>
1	Jet Flap Configurations	33
2	Variable Deflection Thrustor Configurations	34
3	Yuan's and Bailey & Hammer's Models	35
4	Lift Versus Jet Momentum Coefficient	36
5	The Jet Flap Principle	37
6	Gain Versus Jet Momentum Coefficient	38
7	The Coanda Effect	39
8	Photograph of the Model	40
9	Schematic of the Model	41
10	Schematic of the Airfoil	42
11	Schematic of the Set-Screw Device	43
12	Photographs of the Transit and Line Level	44
13	Photographs of the Pitot Tube and Mount	45
14	Schematic of the Wind Tunnel	46
15	Schematic of the Balance	47
16	Velocity Profiles of the Undeflected Jet	48
17	Nondimensional Velocity Profiles	49
18	Average Deviation Versus Distance	50
19	Deflected Velocity Profiles	51
20	Statis Jet Deflection Angle Sensitivity to Control Tube Movement	52
21	Jet Deflection Versus Main Tube Rotation	53
22	Jet Deflection Versus Jet Momentum Coefficient	54

LIST OF FIGURES (CONT)

<u>Figure(s)</u>	<u>Title</u>	<u>Page</u>
23	Balance Data	55
24	Ground Effect on Lift	56
25	Schematic of the Separation Bubble	57
26-31	Photographs of the Smoke Flow	58-63

## LIST OF SYMBOLS AND ABBREVIATIONS

- $C_j$  - momentum coefficient =  $\frac{F_x}{qc}$
- $c$  - chord
- $D$  - % deviation from average velocity =  $\frac{(\sum |V_a - V|)}{V_a N}$
- $F$  - undeflected thrust of jets (measured)
- $F_z$  - thrust in the lift direction (measured)
- $G$  - gain or magnification factor =  $\frac{L_i + L_r}{L_r}$
- $h$  - distance of airfoil from wind tunnel floor
- $L$  - lift
- $N$  - number of data points
- $P$  - regulator pressure
- $q$  - dynamic pressure =  $1/2\rho V^2$
- $U$  - velocity of the jet flow
- $V$  - velocity of the low speed wind tunnel
- $\epsilon$  - main tube rotation angle
- $\delta$  - control tube gap width
- $\theta$  - jet deflection angle
- $\eta$  - turning efficiency =  $\frac{F_z}{F_x}$
- $\rho$  - air density

### SUBSCRIPTS

- $a$  - average
- $i$  - denotes "induced pressure"
- $j$  - jet

LIST OF SYMBOLS AND ABBREVIATIONS (CONT)

- m - maximum
- r - reaction
- s - static
- t - tuned
- x - axis parallel to airfoil chord line
- y - axis parallel to the trailing edge of the airfoil
- z - vertical axis

## ACKNOWLEDGEMENTS

This report for partial fulfillment of the requirement for a Master's Degree in Aeronautical Engineering was submitted to the Naval Postgraduate School, Monterey, California. The author would like to thank Dr. M. Platzer, his thesis advisor, for his guidance and help in this project. The author would also like to acknowledge Mr. W. S. Johnson for his technical assistance and the construction of the test model.

## I. INTRODUCTION

Due to the emergence of V/STOL aircraft and the need for larger helicopters with their greater load carrying capabilities, there has been a growing interest in recent years in high-lift devices. In general, such devices could be named circulation controlled airfoils. The methods of circulation control run the gamut from slotted flaps through boundary layer control to the pure jet-flap. In addition to high-lift applications, circulation-controlled airfoils are also of interest in gust control systems.

The present work is concerned with an exploratory investigation of the jet deflection characteristics of a jet-flapped airfoil using Coanda deflection surfaces. Also, past work on the jet-flap, its aerodynamic principle, and the Coanda effect for jet turning are described.

### A. THE JET-FLAP

The term "jet-flap" originated with the idea that a full span slot along the trailing edge of an airfoil could be used not only for a propulsive force, but also as a means of circulation control. Hence, the name jet-flap is given to any means of obtaining increased lift on a wing by ejecting high velocity air in a narrow sheet from the trailing edge of the wing in a downward inclination to the undisturbed stream. Figure 1 shows the major schemes that have been devised over the years.

The idea of circulation control came as early as 1917 when Föttinger (Ref 16) suggested blowing air over the upper surface of a flap to improve the boundary layer conditions over the wing. It was not until 1931 that his idea was actually tested by Bamber (Ref. 5) who showed that benefits could be derived from this method of circulation control.

These early experimenters confined their studies to relatively low energy jets and it was not until 1939 that "supercirculation" proved its benefits. Hagedorn and Ruden (Ref. 21), using jets of much higher energy than before in their boundary layer experiments, were the first to give a proper explanation for the supercirculation principle. (See page 12)

Between 1939 and 1952 others became involved with the jet-flap but the principle of supercirculation was considered more or less a scientific curiosity because it took a great deal of energy to produce the supercirculation and no source for the large amount of air flow necessary was available at the time.

In 1952, it was H. Constant (Ref. 8), then director of the National Gas Turbine Establishment, who proposed to marry the extremely powerful source of energy then available in the modern jet engine to the jet-flap idea.

His first suggestion was for boundary layer control by injection of part of the jet stream over the mechanical flap. Later the mechanical flap was removed altogether and the whole propulsive jet was brought into play, thus resulting in the "pure jet-flap".

Constant's collaborators Stratford, Davidson and Dimmock (Refs. 12, 13, and 43) performed experimental and theoretical investigations of his concepts. Concurrently, Poisson-Quinton and Jousserandot (Ref. 32) in France also investigated the jet-flap principle. In 1965, Campbell (Ref. 7) performed wind tunnel investigations at NASA Langely Research Center. His model (Fig. 16) incorporated pod-mounted jets that exhausted through a slotted flap.

The problems of the externally blown flap are evident. The intense heat of the exhaust provided an unsuitable environment for the flap mechanism and loss of an engine produced large rolling moments. Primarily because of the exhaust temperatures the externally blown flap concept was little investigated again until the advent of the high-pass-ratio turbofan, with cooler exhaust temperatures.

Another current popular concept of the jet-flap is the internally blown model. It has many design configurations, such as pure jet-flap, augments wing, variable deflector thruster, etc., some of which are shown in Figs. 1a and d, 2a and b. The advantages it has over the externally blown model are greater efficiency, less thrust to produce the same lift, and no control problems in the event of an engine failure because of cross ducting. The obvious disadvantage is a much more complex design because of the required plumbing.

## B. THE JET-FLAP PRINCIPLE

"The principle of the jet-flap is to create jet induced pressure lift," (Ref. 43). Figure 4 shows the lift coefficient of an airfoil-blown flap combination as a function of jet momentum coefficient ( $C_j$ ). The dashed curve represents the theoretically predicted lift of the jet-flap wing in an ideal fluid flow. The curve AB shows the experimentally determined lift. The difference between these two curves represents a loss in lift due to viscous effects. A small amount of blowing energizes the boundary layer sufficiently to prevent separation. Increasing the blowing rate beyond the value at which an attached boundary layer is maintained produces an increased circulation around the wing. This circulation, greater than the "optimum natural circulation" obtained by boundary layer control, is referred to as super-circulation.

Figure 5 is a schematic of the flow over a jet-flapped airfoil. Note that a similar picture would be seen for an airfoil with a mechanical flap. Indeed, the jet-flap owes its name to this similarity. The jet, much in the same way as the sharp trailing edge of the mechanical flap, regulates the circulation around the airfoil. It is easily understood from Figure 5 that air flowing above the wing must be drawn down behind the trailing edge, thus creating a suction above the wing and high pressure region below the wing. The deflection of the jet, therefore, has induced a pressure lift on the wing. This component is often referred to as the "jet

induced pressure lift". In addition, there is a direct lift component due to the jet momentum in the lift direction which is called the "reaction lift". A measure of the jet-flap effectiveness is given by the ratio of jet induced pressure lift plus reaction lift to reaction lift alone. This is the "lift gain factor", (G). The theoretical dependence of the lift gain factor on the jet momentum coefficient is shown in Figure 6. Noteworthy are the large lift gain factors at small blowing rates ( $C_j$ ).

Several hypotheses have been proposed and mathematically proven using the assumptions of two-dimensional, ideal fluid flow (no mixing between main and jet stream fluid and zero profile drag). These hypotheses are submitted for further edification and insight into the workings of the jet-flap.

#### The Thrust Hypothesis

Davidson (Ref. 12) states the thrust hypothesis as:

"In an idealized two dimensional jet-flap system the gross thrust is equal to the total jet reaction independent of the angle of deflection of the jet."

This hypothesis can be proven using the control volume technique. (Ref. 42)

#### The Lift Hypothesis

Stratford (Ref. 42) states, "If in a two dimensional system a jet issues from the trailing edge of an airfoil, aerodynamic lift will be induced on the airfoil in addition to the direct vertical component of the jet thrust. The usual stall limitations on lift will not apply as there will

be a suction pressure peak at the trailing edge of the airfoil. Further, the center of the lifting force thus created will be near the 50% chord line and not near the jet."

### C. COANDA EFFECT

The methods for introducing high velocity air at the trailing edge vary widely. Yuan, et al (Ref. 49), in his experiments used a fixed slot at the trailing edge. (Fig. 3a) Bailey and Hammer (Ref. 4) and Kind and Maull (Ref. 28) used a model incorporating the Coanda effect. (Fig. 3b)

The Coanda effect owes its name to Coanda, an early experimenter and inventor, who observed the effect but never really investigated it. This phenomenon is basically the tendency of a free running fluid to attach and flow next to a solid surface. Once attached it is usually referred to as a "wall jet".

The basic mechanism of the Coanda effect can be understood from the following considerations. If a flat surface, which is parallel to the jet axis, were moved close to the jet boundary, the originally stagnant air between the jet boundary and the wall would be entrained by the jet. Since the wall prevents inflow of new air, a low pressure region is formed between the wall and the jet boundary. The pressure differential between the ambient air and the low pressure region near the wall causes the jet to attach to the wall and remain attached. (Fig. 7a)

The same phenomenon occurs if a flat surface were inclined away from the jet axis or if a curved surface were used. For a curved wall jet the radially outward directed centrifugal force and the pressure force are in equilibrium. This physical explanation of the deflection of the flow was given by Squire (Ref. 42). (Fig. 16)

Von Glahn (Ref. 44) studying this effect with single and multiflat plate sections found that the turning angle was a function of jet height, plate length and nozzle pressure ratio. Korbacher (Ref. 29) found that he could get much better turning efficiencies,  $\eta$ , by using smoothly curved surfaces. Another important result of Korbacher's tests was that the turning efficiency was little affected by the downstream distance of the deflecting surface. Bailey (Ref. 3) working with subsonic choked and overchoked jet sheets obtained turning efficiencies of 92% (page 6) with a pressure ratio of 2:1 and predicted that a decrease in turning efficiency would be seen in supersonic flow due to shock separation. However, Roderick (Ref. 38) disproved this by showing that turning efficiencies were decreased slightly by supersonic flow "due to somewhat higher frictional losses with higher jet sheet velocities".

Benner (Ref. 6) supported Korbacher's findings about the horizontal distance of the deflection surface having little effect on turning efficiency. But he also came to some other interesting conclusions; one was the thickness of the jet sheet and its effect on turning efficiency: a larger thickness producing less turning efficiency. Another was the

radius of the deflection surface and its effect on the tolerance of the apparatus to horizontal gap sizes between nozzle and deflection surface: a larger radius permits a larger horizontal gap.

#### D. OBJECTIVES OF THE PRESENT STUDY

It is obvious that the jet-flap is an excellent concept for high lift applications, but it has many other appealing aspects. The one to be considered in this study is its possible future application as a gust generator/gust alleviator.

In recent years, increased attention has been directed towards the development of aircraft load alleviation and mode stabilization on a B-52 test aircraft incorporating an active LAMS system which used conventional control surfaces. It is clear that the jet-flap could offer considerable advantages for such a system because movable surfaces are not needed and mechanical and inertial effects are eliminated.

Another usage of equal import might be the application of jet-flap technology to the rotor-vibration-suppression problem on helicopters offers great opportunities for the development of improved high-performance helicopters. A helicopter rotor vibration control system using jet-flaps is presently under development by Honeywell, Incorporated. This device which is now generally referred to as the variable deflection thruster (VDT) is shown in Figure 2b. It consists of a cylindrical surface on which as many as two jets can issue from diametrically opposed slots. The jets originate

behind the cylinder from two plenum chambers and meet on the surface of the cylinder at a position determined by the pressure difference between plenum chambers. Hence, in addition to producing a thrust, the VDT permits the increase of airfoil lift by increasing the jet momentum or the jet angle or by increasing both. The system appears to have been proposed by Kind (Ref. 38) and experimental work was carried out by Kind and Maul (Ref. 28). For a recent comprehensive helicopter study of the VDT jet-flap, the reader is referred to a study performed by Bailey and Hammer (Ref. 4)

The application of the jet-flap to gust control of large flexible aircraft was recently studied by Simmons and Platzler (Ref. 41) who used both mechanically and fluidically controlled jet-flaps as shown in Figure 2a and as documented in Ref. 24.

It is the objective of the present and future studies to examine the characteristics of this model with regard to gust generation/gust alleviation applications. However, before investigating the time dependent characteristics, it was felt necessary to explore the steady-state operation of the model. Therefore, the following specific objectives were considered for the present study:

1. Investigate the characteristics of the undeflected jet.
2. Investigate the jet turning performance of the model in still air.
3. Investigate the jet turning performance of the model in the low speed tunnel using smoke visualization techniques.

## II. DESCRIPTION OF TEST APPARATUS

A jet-flap model was designed by Professor M. F. Platzer and built to specifications by Mr. W. S. Johnson. Since it will eventually be used as a gust generator, the model incorporated two truncated NACA-0010-66 aircraft sections (Ref. 1) using 84% of the chord length with a span of 14.9 inches. (Figs. 8-10) Mounted in the trailing edges of both of the airfoils were three tubes. The largest of these tubes (5/8" I. D.), the main tube, contained 56 holes of .029" diameter spaced 1/4" apart. The main tube was mounted at both ends in roller bearings to allow rotational freedom. Behind the main tube, two (1/4" I. D. ) control tubes were mounted in brackets that allow vertical adjustment through the use of set screws. (Fig. 11) The useful vertical movement was a maximum gap size of .218" to a minimum of .06". These tubes were also designed for air flow having the same number of holes (.029" diameter) with the same spacing as the main tube. This means of blowing, however, was not used in any of the experiments performed. The airfoils were mounted between two panels, one made of plexiglass for flow visualization purposes. (Fig. 9) The distance between the top airfoil and the base of the model was 27". This made the ratio of the distance between the airfoil and the wind tunnel floor to chord length 2.7.

#### A. NECESSARY SUPPORTING EQUIPMENT

The air source used was that installed in the basement of Halligan Hall and routed to the various shops and bay areas. Because of the unforeseen demands on this source it was always necessary to incorporate a pressure regulating device in the line. This source was capable of supplying approximately 600 cfm at a pressure of 40 psig with one compressor on the line and 700 cfm at 50 psig with both compressors running. Higher pressures were not used. It was found necessary to also install a sump and dehumidifier in the line due to an extreme amount of condensation occurring in the compressor and associated plumbing.

#### B. DETERMINATION OF PITOT TUBE POSITION

To establish the position of the 1/8" O.D. pitot-static tube in the flow field a line level and a transit were used. The transit was mounted in a special slide (Fig. 12a) for measuring the downstream distance of the pitot-static tube. The line level was used for measuring the elevation of the pitot-static tube and was kept in its original stand (Fig. 12b). The spanwise distance was manually measured with a length scale or ruler.

It should be noted that in the present study air was blown only from the top airfoil. The bottom airfoil was always left inoperative.

### III. TEST PROCEDURE

#### A. STATIC TESTS (JET UNDEFLECTED)

The main tube was rotated into a position placing the jet parallel to the chord-line and equidistant from the control tubes. Flow velocity profiles were measured in the vertical and horizontal planes.

With a slide bar atop the model, the pitot-static tube (Fig. 13a) in a special mount could be located at virtually any point in the flow. (Fig. 13b) The metal bar was aligned in the streamwise direction approximately mid-span. Vertical velocity profiles were taken at several downstream locations at two spanwise stations. Since there were no major differences between the two spanwise stations, only one of them has been reproduced in graphical form (Fig. 16).

The next step was to obtain velocity profiles in the horizontal plane. In doing so, the slide-bar was mounted parallel to the trailing edge of the wing at several downwind stations and velocity profiles were measured on the jet centerline. It should be noted that a fixed interval between adjacent points would in the extreme case have given a very distorted picture. If, for example, the measurements had been taken exactly at  $1/4$ " intervals, at .8 inches downstream, one would have seen the same velocities at each point since the hole spacing on the main tube was  $1/4$ ". For this reason, the horizontal velocity measuring points were chosen at random.

As was expected, the velocities were very erratic near the trailing edge due to the jets blowing from many individual holes. Furthermore, complete mixing of adjacent jets was never realized even to distances of eight inches from the exit plane of the jets. It was decided to represent this data in the form of the average deviation from the average velocity found at any particular station as a function of distance. (Fig. 18) In effect, this gives an idea of the amount of mixing at any given station, since if the deviation were 0%, the discrete sources would have completely coalesced into each other forming a two dimensional jet sheet.

#### B. STATIC TESTS (JET DEFLECTED)

In these tests, the gap width ( $\sigma$ ) was set at .218 inches, the main tube angle at +11 degrees for maximum Coanda deflection as indicated by a tuft, and the main jet pressure at 30 psig. The probe was aligned with the flow as indicated by the tuft and velocity profiles were taken. (Fig. 19) Notable is the dissymmetry of the profiles which is in qualitative agreement with velocity profiles taken by Fernholz (Ref. 15) on a Coanda surface of much larger radius.

From the deflected velocity profiles it was decided to use the maximum velocity as an indication of the turning angle of the jet. Turning efficiency,  $\eta$ , is usually defined in terms of the ratio of measured vertical force to the measured thrust of the undeflected jet. However, at this stage of the experiments it was impractical to mount the model on a balance and

hence  $\eta$  could not be measured.

Using the maximum velocity as the criterion for turning angle, the next series of tests involved changing some of the parameters that could affect the turning angle. First, the pressure in the main tube was varied from 20 to 40 psig with main jet angle at 11 degrees and the gap width at .218 inches. No recordable change was noted in the turning angle. Next, the gap width was at first set at .175 inches and then the top control tube was moved closer in steps with the main tube set at zero jet angle. The results are plotted in Figure 20. This gave an indication of the minimum distance to which the control tubes could be set without flow attachment.

To investigate the dependence of the main jet angle on control tube gap width, the control tube gap was set, and the main tube was rotated one degree at a time. Both main tube angle and jet deflection were recorded. The results are plotted in Figure 24.

### C. WIND TUNNEL TESTS

For flow visualization purposes and further experimental investigations, the model was moved into the low speed flow visualization facility located in Bay 2 in Halligan Hall. This facility is essentially a three-dimensional smoke tunnel as shown in Figure 14. It is modeled after the one described in Ref. 37. The air inlet is a square bell-shaped configuration containing a honeycomb three inches thick followed by one layer of screen. The inlet area is 15 x 15 feet and contracts downstream to a 5 x 5 x 12 foot square

test section. One side of the test section has a plexiglass window for observation of the model. The turbulence level has been determined by J. F. Costello (Ref. 11) using a hot-wire anemometer. In the speed range from 6 fps to 32 fps the highest level was 0.97% and the lowest level was 0.47%.

Using a Polaroid land camera with film having an A.S.A. of 3000, pictures of the flow were attempted using smoke as a flow visualization device. It was found that the high intensity Colortran lights that were originally used for illumination caused an inordinate amount of glare from the plexiglass on the observation window and the test model. Therefore, it was decided to use a lower intensity focusable light. Three high pressure mercury arc light sources, which are of very low intensity and have a lens for focusing, were mounted on a pole downstream of the model. They were then focused at the point the smoke would be transiting the airfoil. All lights in the observation room were extinguished and pictures were taken with exposure times from one to four seconds with the maximum lens opening. Some of the photos are shown in Figures 26-31. One can also see the tuft that was attached to the wing in these photos.

For data taking purposes, the tunnel was run at fixed speeds of 10, 15 and 20 fps which were set using a micro-manometer with alcohol as a medium for sensitivity. The control tube gap width was adjusted for each run and the main tube angle was set for maximum deflection using the tuft as a guide. It was decided to use the tuft as the

primary means of measuring since it was at a fixed point and the gap width could be taken there. Deflection angles taken from the tuft versus  $C_j$  for various gap widths are plotted in Figure 27.

#### D. BALANCE TEST

Finally, the model was disassembled and the airfoil that had been tested was remounted on an Aerolab Research Company Model 543 Wind Tunnel Balance to perform turning efficiency tests. (Fig. 15) To compute  $C_j$  tests were performed to find the undeflected thrust. To that end, care was taken to use the same length of inlet hose to both the main jet and the corresponding pressure gauge.

The pressure was set at 21, 30, 40 and 50 psig respectively with the main tube positioned so that only drag (undeflected thrust) readings were registered on the balance. Then for each of the previous pressures the main tube angle was set to give the maximum jet deflection as indicated by a tuft for a gap width of .19 inches. Lift and drag values were recorded.

It was decided at this time to try to "tune" the model to give the maximum lift reading possible by making slight adjustments to the control tubes and the main tube. Results are given in Figure 23.

#### IV. DISCUSSION OF RESULTS

Before discussing any specific experimental results it is important to note a few of the discrepancies in the model itself. In doing so, possible explanations of some of the test deviations are evident.

Apparent at the start of the experiments was the slight misalignment of the holes in the main tube. If one were to look at the trailing edge of the airfoil, one would note that the holes in the main tube were noticeably skewed down from right to left.

Although the set-screw devices assured the accuracy of the control tube gap at the ends of the airfoil, there was often as much as a 15-16% deviation along the span. This was due to two factors: 1) the control tubes were made from stock, unpolished aluminum tubing which were not straight and 2) at the maximum control gap width, the tubes had a tendency to bind on the trailing edge fairing of the airfoil.

##### A. STATIC TESTS (UNDEFLECTED)

Although the mathematical formulas for determining the velocity in two- and three-dimensional and axisymmetric free jets are different (Ref. 2 and 40), Abramovitch and Schlichting indicate that experimentally determined dimensionless plots differ only slightly. Figure 17 is a dimensionless plot of the vertical velocity profiles of the three-dimensional jets of the main tube for various downwind stations. Plotted also,

is the curve for a two-dimensional jet obtained by Forthman. (Ref. 2) The agreement is reasonably good between the data points and the curve.

Figure 18 shows the average deviation from the average velocity found in the horizontal plane. As was previously mentioned, this form of graphing the results was decided upon to show just how two-dimensional the discrete jets had become. As was expected, there is a sharp drop in the deviation as one goes downstream to a distance of five inches. After five inches, there is a slight increase in the deviation. It is felt that this increase is due to the technique involved in taking the data points. At the more distant downstream stations, a maximum value of velocity was determined by moving the pitot tube around in the flow field while observing the manometer. Once the maximum velocity had been established, the distance between measuring points, although still randomly chosen, had to be greater to get a significant change in the manometer reading. It is felt, therefore, that beyond five inches the results are shaded by the fact that the mean distance between measurement points was increased, and also, that not enough data points were recorded to get a good average velocity.

#### B. STATIC TESTS (DEFLECTED)

Figure 19 shows the velocity profiles of the deflected jet. It is felt that these results should be looked at in a qualitative rather than quantitative way, since there was

no flow direction device used in obtaining these results. Notable in the profiles is the dissymmetry, which is in agreement with Fernholz (Ref. 15) who measured velocity profiles around a Coanda surface of much larger radius.

Figure 20, a plot of jet deflection angle versus control tube movement, shows just how sensitive this model was to control tube gap width. A change of .040" or approximately 25% of the maximum gap width available, changes the jet deflection by 30 degrees or more once the jet has started to attach to the control surface. After jet attachment, it becomes even more sensitive to control tube gap width. Also, the minimum control tube gap distance appears to be approximately .15 inches. If the control tube gap size were decreased much beyond .15 inches with the main tube angle set at zero, the jet would attach to both control tubes simultaneously and the control tubes would serve as a two-dimensional diffuser section.

Figure 21 shows that the control tube gap had little effect on the maximum turning angle of the jet. Notice, however, that the main tube rotation was considerably reduced for any given jet deflection angle the smaller the gap size. It was not felt that the part of the curve past the maximum turning angle was relevant to the study of this model. The decline in the jet turning angle was due to the air flow starting to pass behind the control tube, between the control tube and the trailing-edge fairing of the airfoil. At this point, the control tube simply began to be a normal cylinder in a flow field.

### C. WIND TUNNEL TESTS

The flow visualization tests that were performed proved to be quite gratifying. The low speed visualization facility was a useful device for observing the flow past the airfoil. The only possible complaint one could have would be that when taking pictures of the flow, the smoke generator was quite erratic in its operation. Figures 26-31 bear out this fact. Although some individual photographs are extremely good, a wide variation in the quality can be seen. This variation is due to the uncertainty of camera exposure time needed for any given run due to the erratic generation of smoke.

Figures 26-28 are photographs of the airfoil with the jet deflected to its maximum limit for various jet momentum coefficients and control gap widths. Figures 28-31 are photographs of the airfoil with the jet at intermediate angles for various jet momentum coefficients and control gap widths. Figure 22 is a plot of jet deflection angle versus jet momentum coefficient for various gap widths. The data for this graph was taken from Figures 26-28. The results show that there is no definite trend when the control tube gap width was changed. As was the case in the static test, less main tube rotation was needed to deflect the jet to its maximum value as the gap width was reduced. However, once the maximum angle had been established, there was no noticeable dependence on gap width for any given jet momentum coefficient.

It is interesting to note the definite appearance of the separation bubble in Figures 26-28 for the higher jet momentum coefficients. Compare these photographs with Figure 25 which

is a schematic of the separation bubble obtained from Ref. 12.

Also, note that there is a likelihood of wind tunnel interference at the higher jet momentum coefficients. Reference 22 provides some information in this regard, from which Figure 24 has been reproduced. It shows the effect of varying ground distance on the lift of a two-dimensional jet-flapped airfoil. The ratio of height to chord ( $h/c$ ) in the present tests is 2.7.

#### D. BALANCE TESTS

These tests were primarily performed to obtain the undeflected thrust of the model. However, to get a general idea of the turning efficiency of the Coanda surfaces on the model, a cursory examination of the turning efficiencies was made.

Figure 23 shows in tabular form the data obtained in the balance tests. Note a 4 to 6.5% increase in turning efficiency due to "tuning" the control tube. Also note that the most efficient position is at a jet deflection of 71 degrees and not at the maximum jet turning angle of approximately 84 degrees. However, this may be explained by the following considerations. The jet deflection angles of the model while on the balance were computed using a lift and drag measurement. Using the balance to determine turning angles in this manner, averaged out all deviations of the spanwise deflected jet. Previous deflection angles were taken using a tuft at a

specific point in the flow without averaging. Therefore, the discrepancy between these two angles could be due to the difference in methods of determining the jet deflection angle.

The turning efficiencies obtained were low when compared to such standards as set by Von Glahn (88%) and Hiller Aircraft Corporation (92%). It should be mentioned, however, that they were using two dimensional jets and highly polished Coanda surfaces. Their Coanda surfaces were also very large and not intolerant of small deviations in control surface alignment. The jets in this study were three-dimensional in nature, the surfaces were unpolished and the model was very sensitive to misalignment, all of which were factors that decreased the efficiency of this model.

#### E. SUMMARY OF THE STUDY

This study had the overall objective of taking a preliminary look at the proposed gust generation/gust alleviation model. In general, these experiments are by no means complete but do serve the purpose of giving an overall view of the static performance of the model. In addition, they point out the necessity for future investigations in the following areas:

1. Detailed investigations of static deflected velocity profiles using a flow direction device.
2. Wind tunnel investigations of the study flow characteristics (including detailed velocity measurements).
3. Investigations of the oscillating flow characteristics of the model (including frequency response studies).

## V. CONCLUSIONS AND RECOMMENDATIONS

1. The jets issuing from the main tube were three-dimensional, thus, an erratic span-wise distribution was created. However, two-dimensional assumptions at stations five inches downstream and beyond would be acceptable since the deviation was approximately 6% or less.
2. The deflected velocity profiles serve only as a cursory look at the flow field and a more detailed investigation is needed using a yaw meter or some similar device to obtain flow directions.
3. Although the turning efficiencies were low (53%), it is felt that this model is aptly suited for gust generation/gust alleviation applications.
4. The smoke flow visualization facility lends itself well to the study of the flow environment around this model. Its use in oscillating flow conditions would prove an invaluable aid in visualizing the dynamic characteristics of the model. However, some means of generating a more stable efflux of smoke is needed.
5. Turning efficiencies might be greatly improved through:
  - a) the use of spacers between the control tubes to fix the control tube gap at a set distance, and b) the use of polished control tube surfaces to reduce the viscous losses. The spacers would serve the additional function of making the flow around the control tubes more two-dimensional in nature, thereby increasing the turning

efficiency. The use of stainless steel tubing would be preferable to the aluminum tubing due to its strength and higher quality surface.

6. One of the main objectives of the present work was a study of the overall turning performance. It is felt that the measurements are sufficient in this regard. Furthermore, the influence of control tube width and main jet angle has been established.
7. Finally, further detailed velocity and pressure measurements for steady and time-dependent (oscillatory) operation of the jet-flap are needed.

FIGURE 1. JET -FLAP CONFIGURATIONS

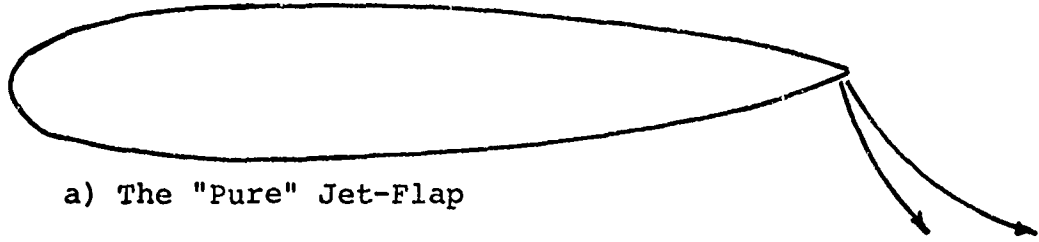

a) The "Pure" Jet-Flap

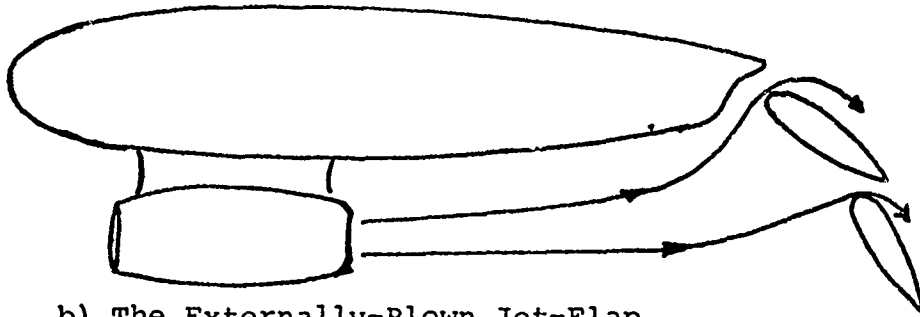

b) The Externally-Blown Jet-Flap

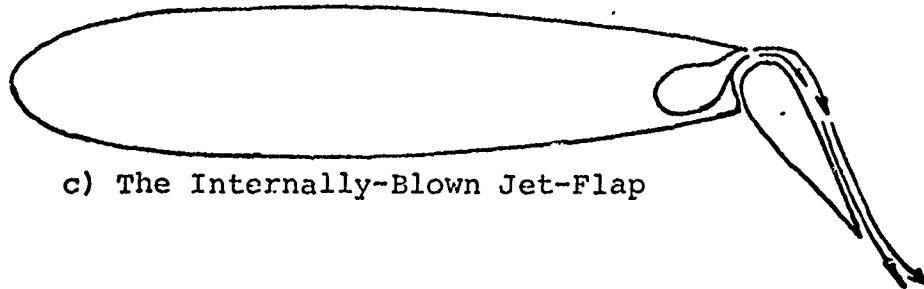

c) The Internally-Blown Jet-Flap

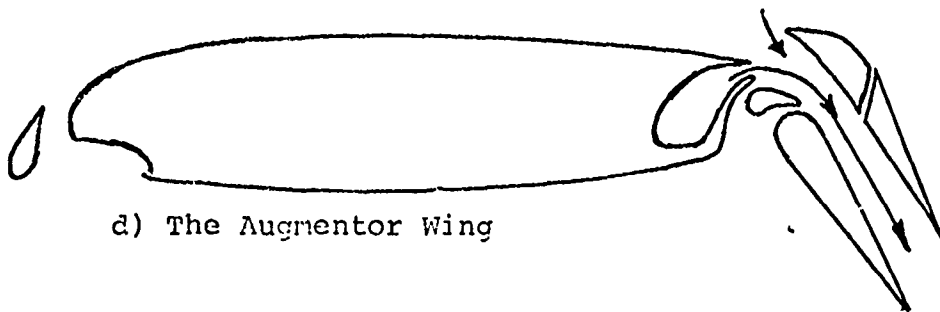

d) The Augmentor Wing

FIGURE 2. VARIABLE DEFLECTION THRUSTER (VDT)  
CONFIGURATIONS

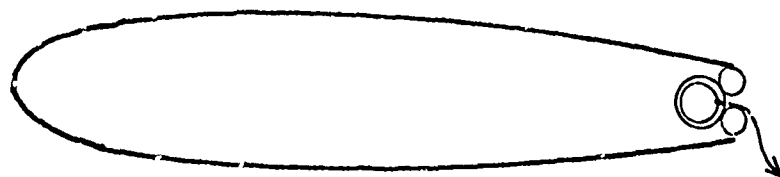

a) Refs. 24 and 41

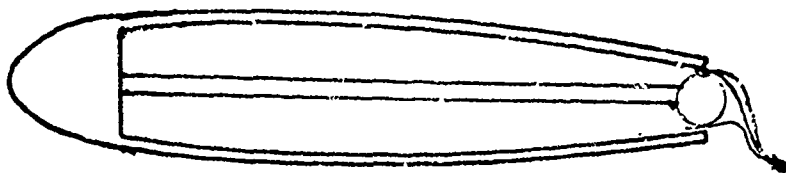

b) Refs. 4 and 28

FIGURE 3. SPECIFIC JET-FLAP MODELS

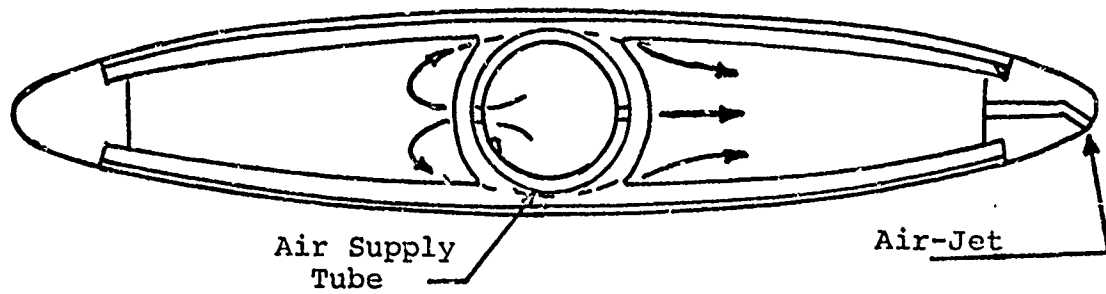

a) Yuan (Ref.49)

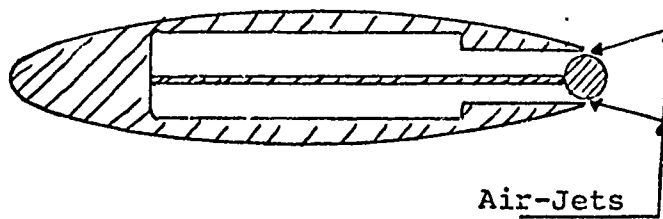

b) Bailey and Hammer (Ref. 4)

FIGURE 4. LIFT VERSUS JET MOMENTUM COEFFICIENT (REF. 22)

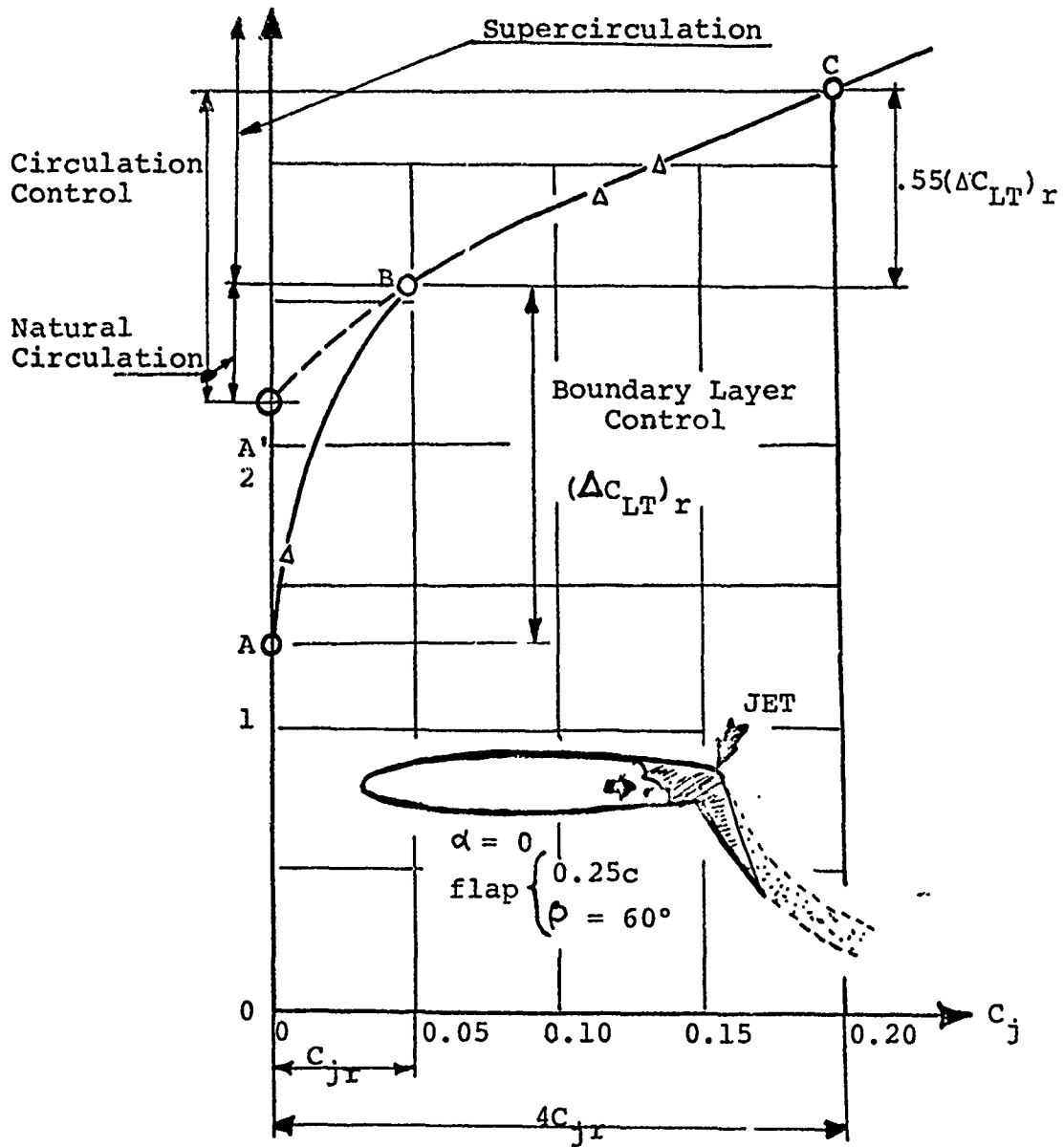

FIGURE 5. THE JET-FLAP PRINCIPLE (REF. 43)

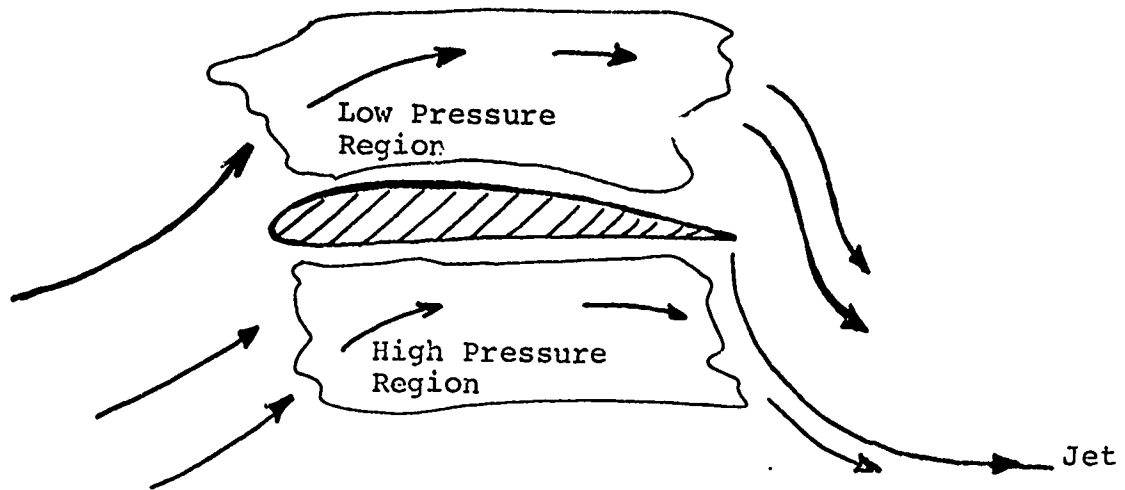
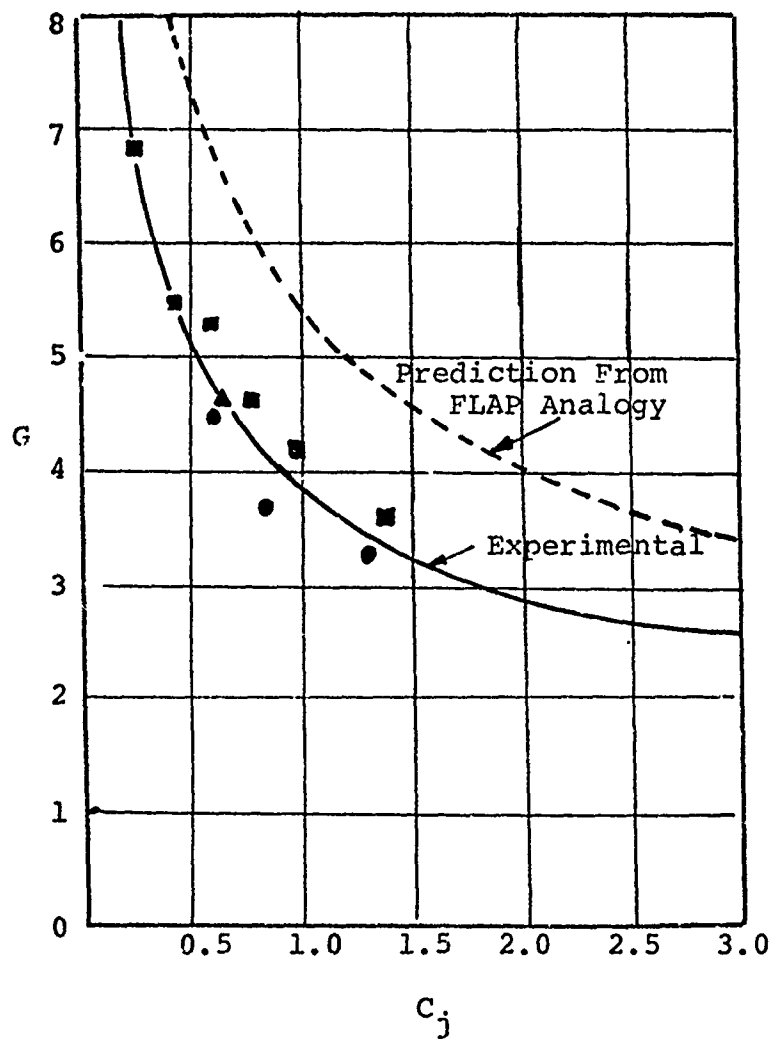
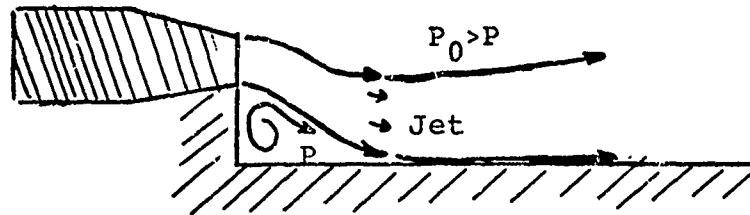
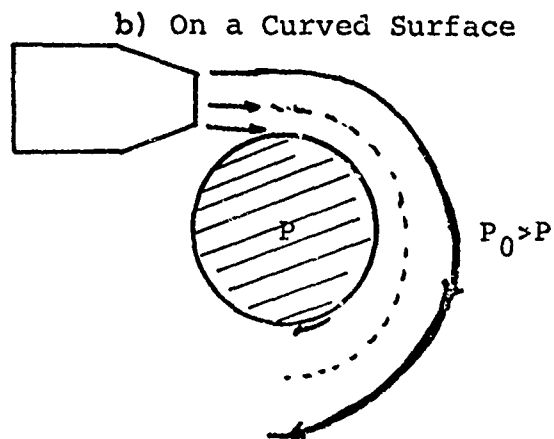

FIGURE 6. GAIN VS. JET MOMENTUM COEFFICIENT (REF. 31)





a) On a Wall



b) On a Curved Surface

FIGURE 7. THE COANDA EFFECT

FIGURE 8. PHOTOGRAPH OF THE MODEL.

Reproduced from  
best available copy.



FIGURE 9. SCHEMATIC OF THE MODEL

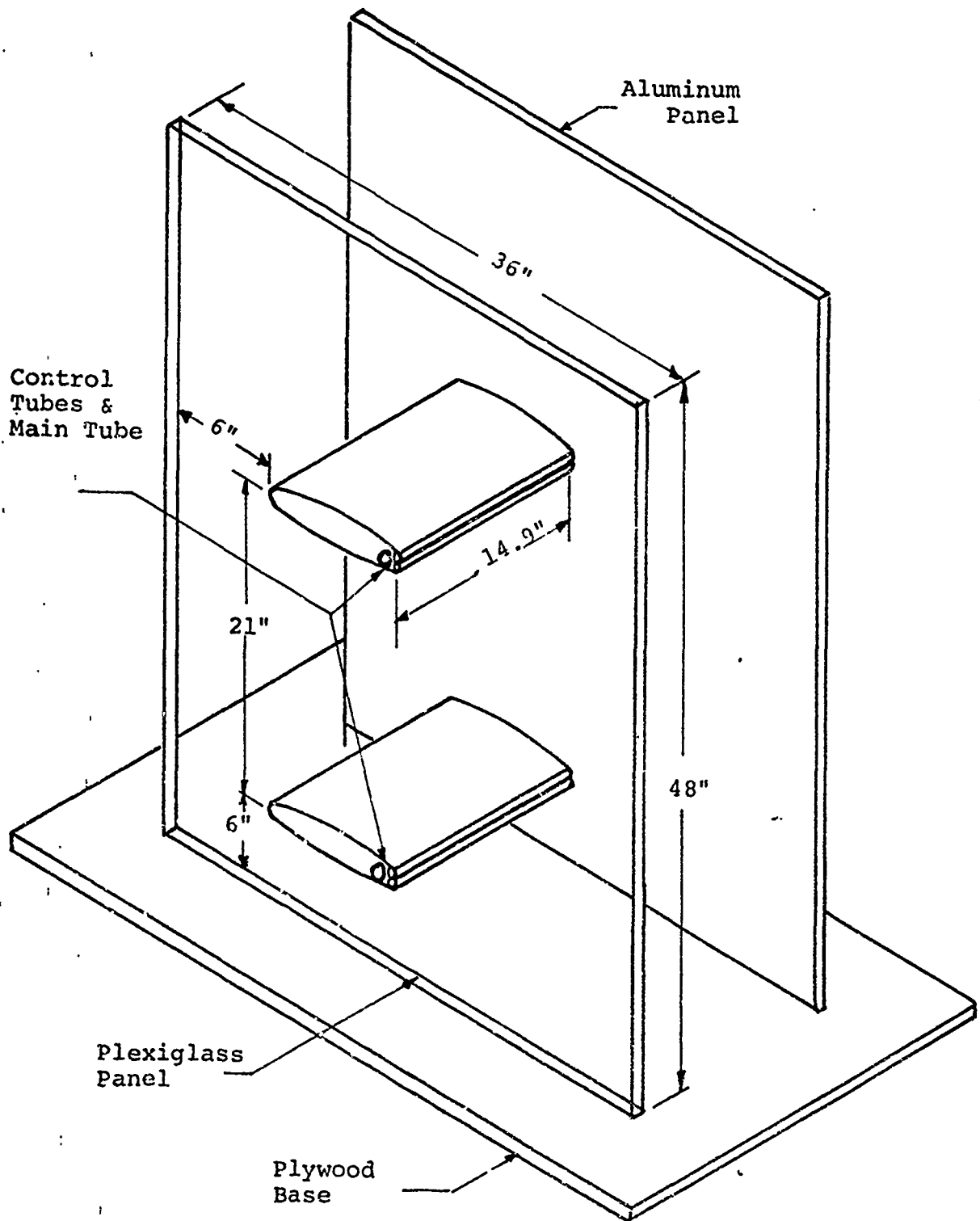

NACA 0010-66

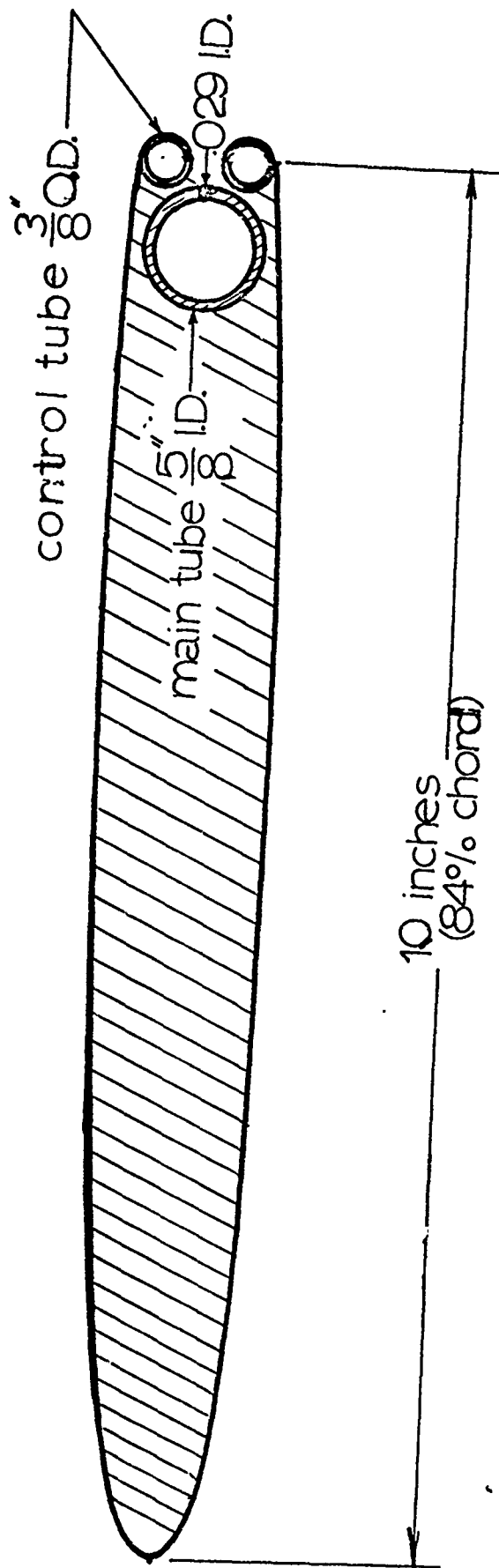

FIGURE 10. JET FLAP MODEL

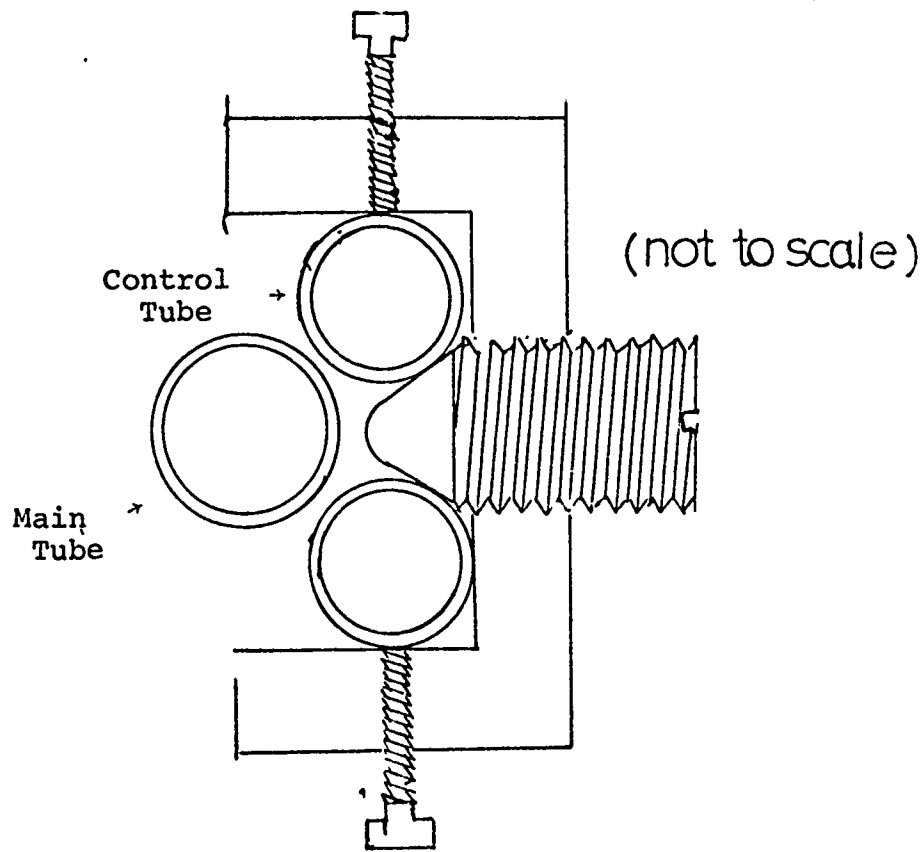
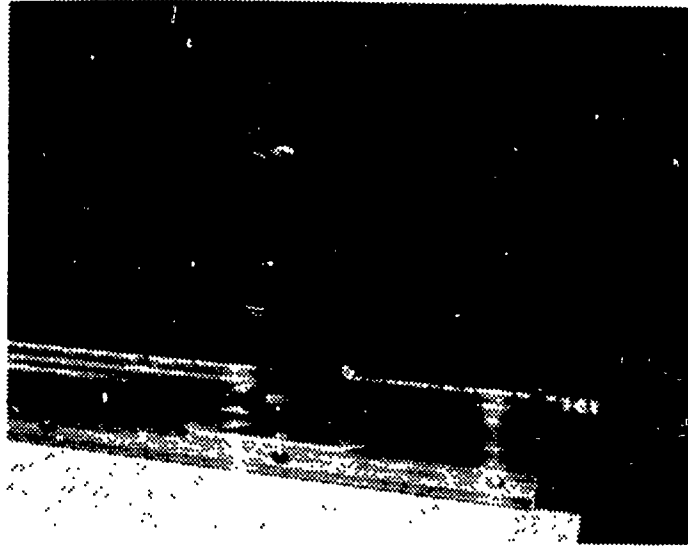

FIGURE 11. CONTROL TUBE SET-SCREW DEVICE

FIGURE 12. PHOTOGRAPHS OF TRANSIT AND LINE LEVEL



a) Transit

Reproduced from  
best available copy.

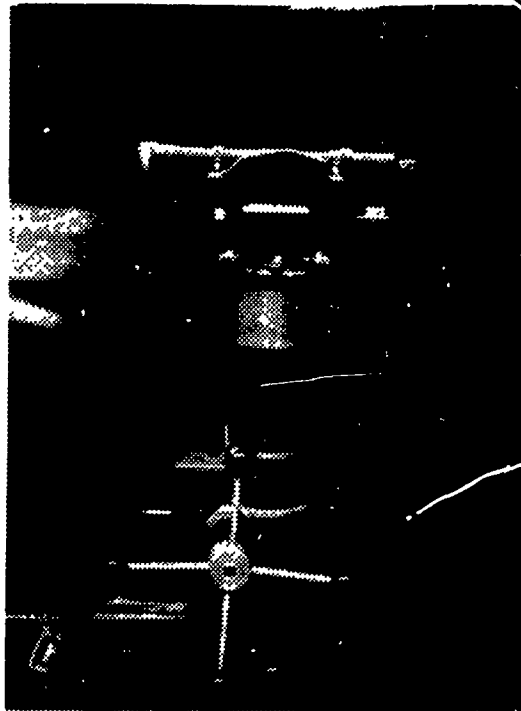

b) Line Level

FIGURE 13. PHOTOGRAPHS OF PITOT TUBE AND MODEL

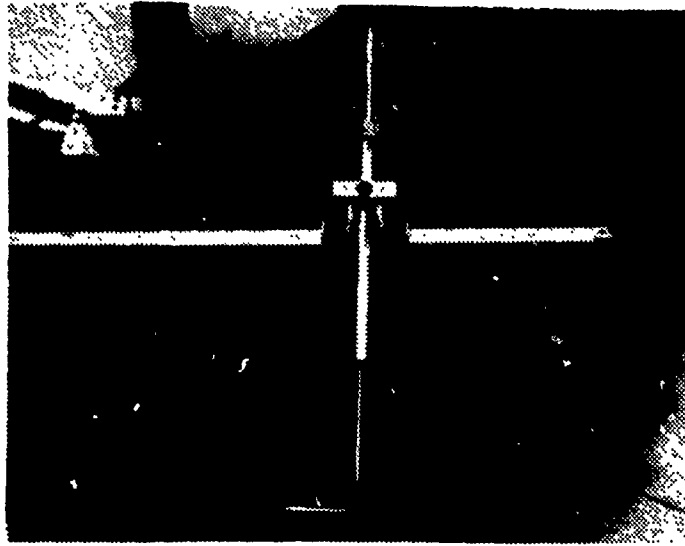

a) Pitot Tube and Mount

Reproduced from  
best available copy.

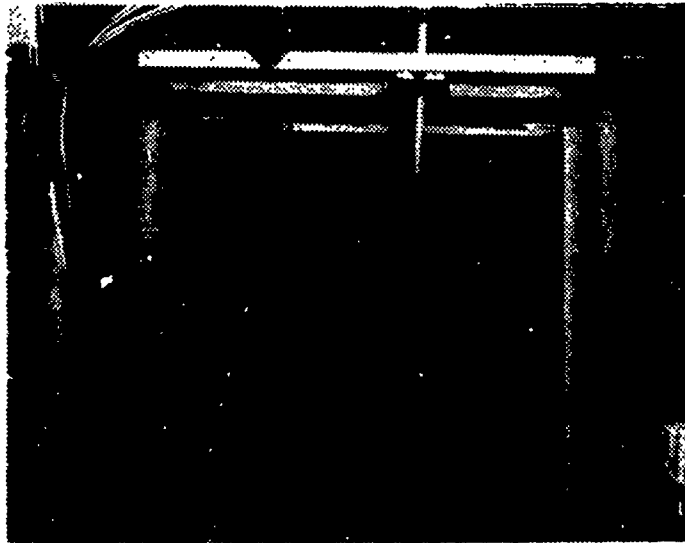

b) Pitot Tube Mounted on the Model

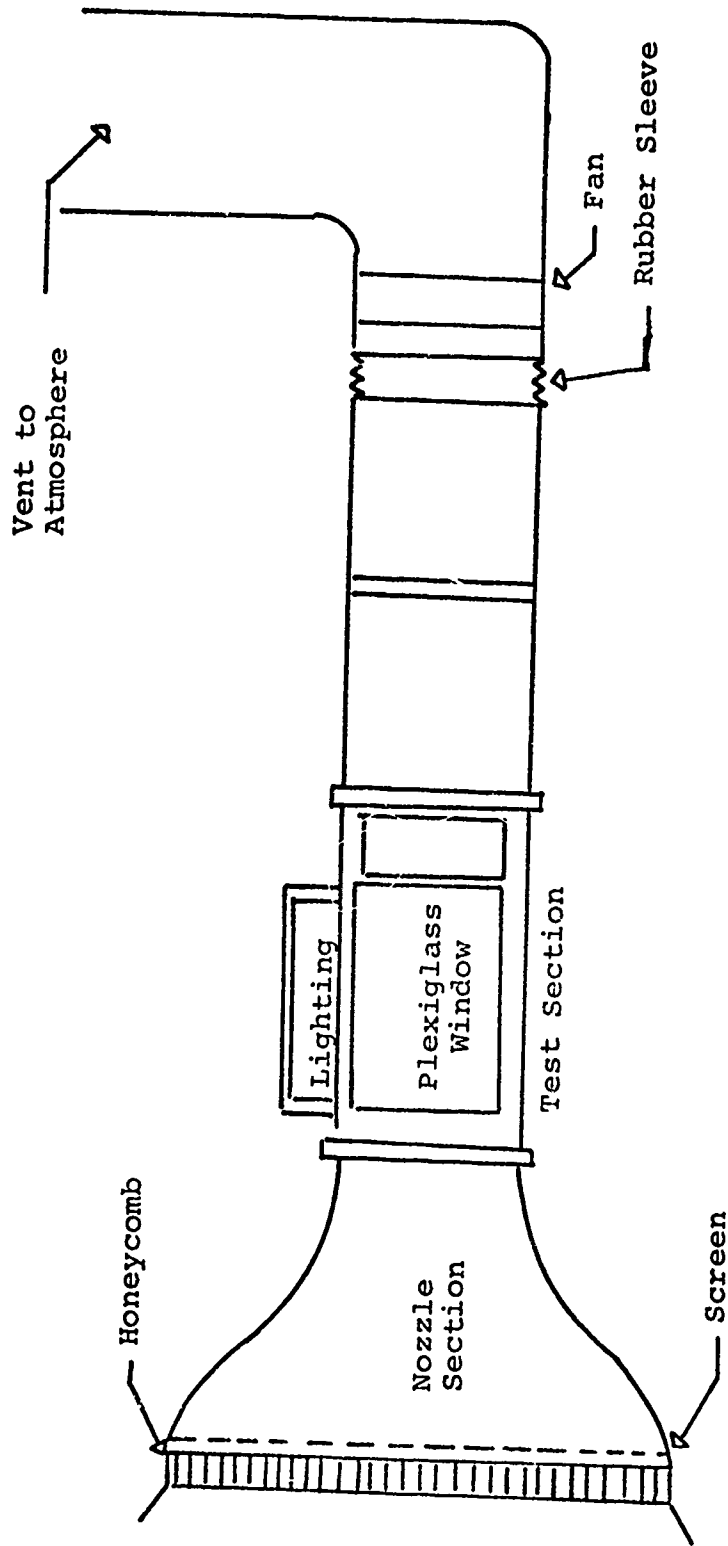

FIGURE 14. SCHEMATIC OF NAVAL POSTGRADUATE SCHOOL FLOW VISUALIZATION FACILITY (REF. 11)

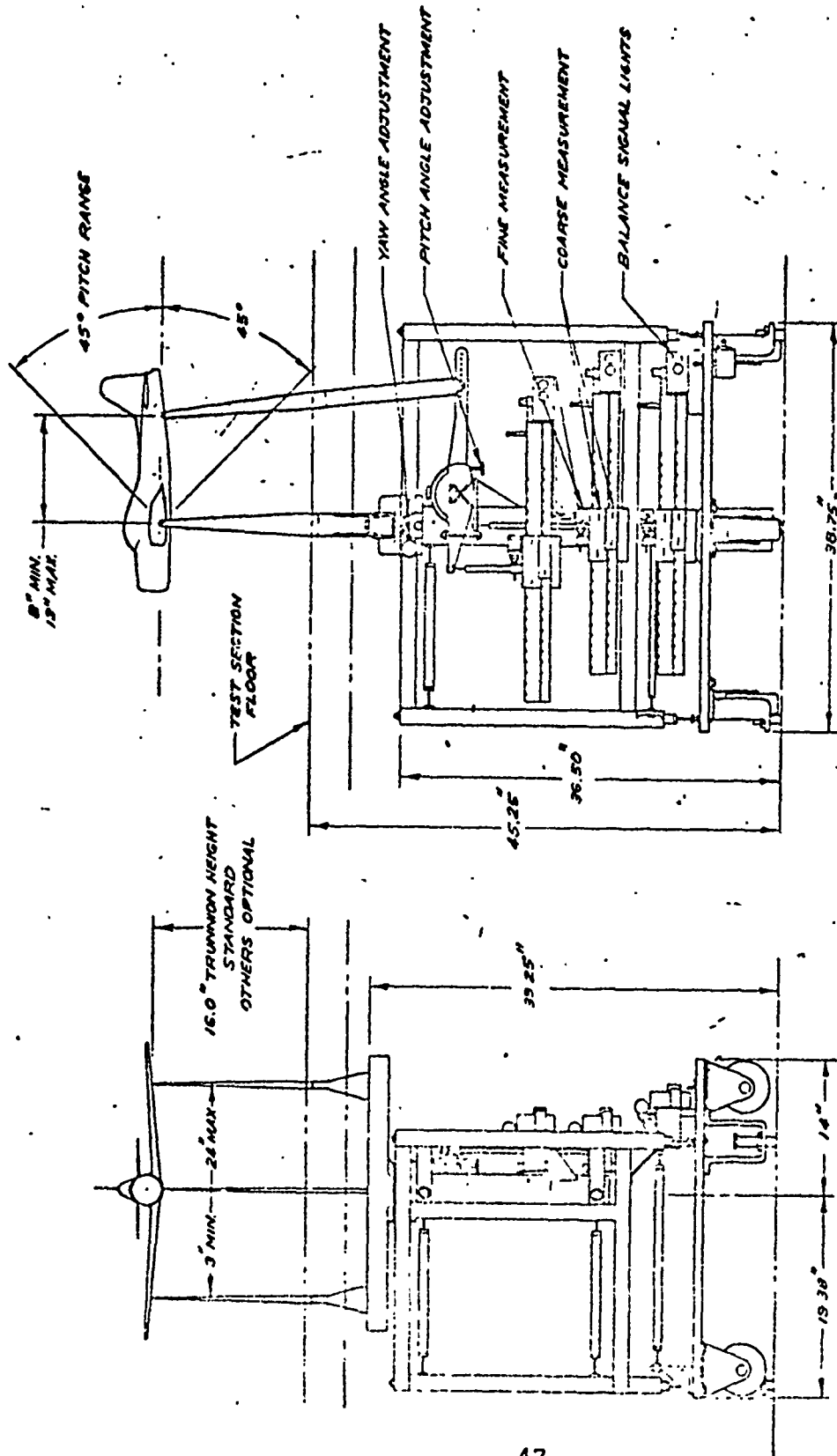

FIGURE 15. AEROLAB 3 COMPONENT BEAM BALANCE

FIGURE 16  
 VELOCITY PROFILES  
 of  
 THE UNDEFLECTED  
 JET

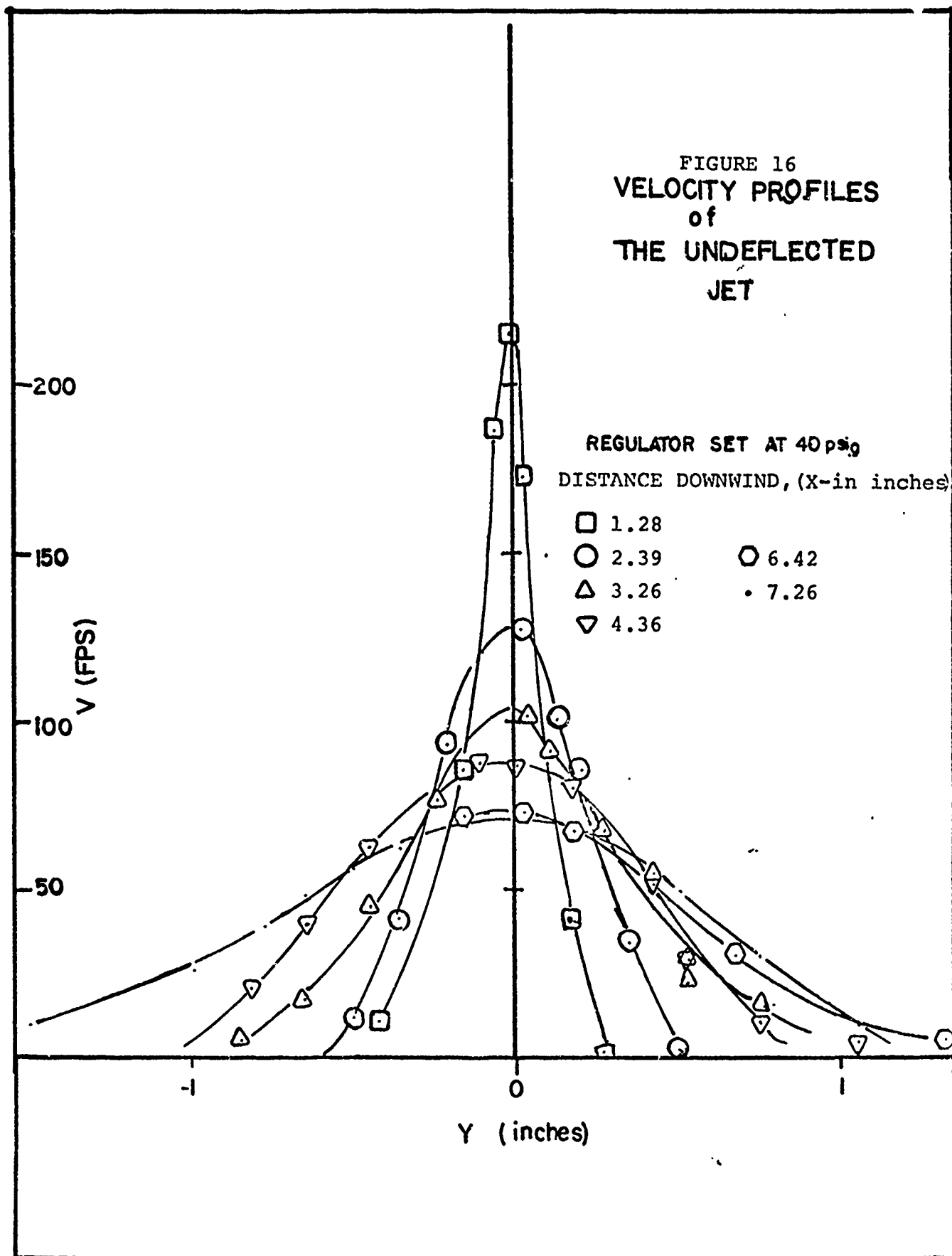

FIGURE 17.  
 NORMALIZED AND NON-DIMENSIONAL  
 VELOCITY PROFILES FOR SEVERAL  
 DOWNWIND STATIONS

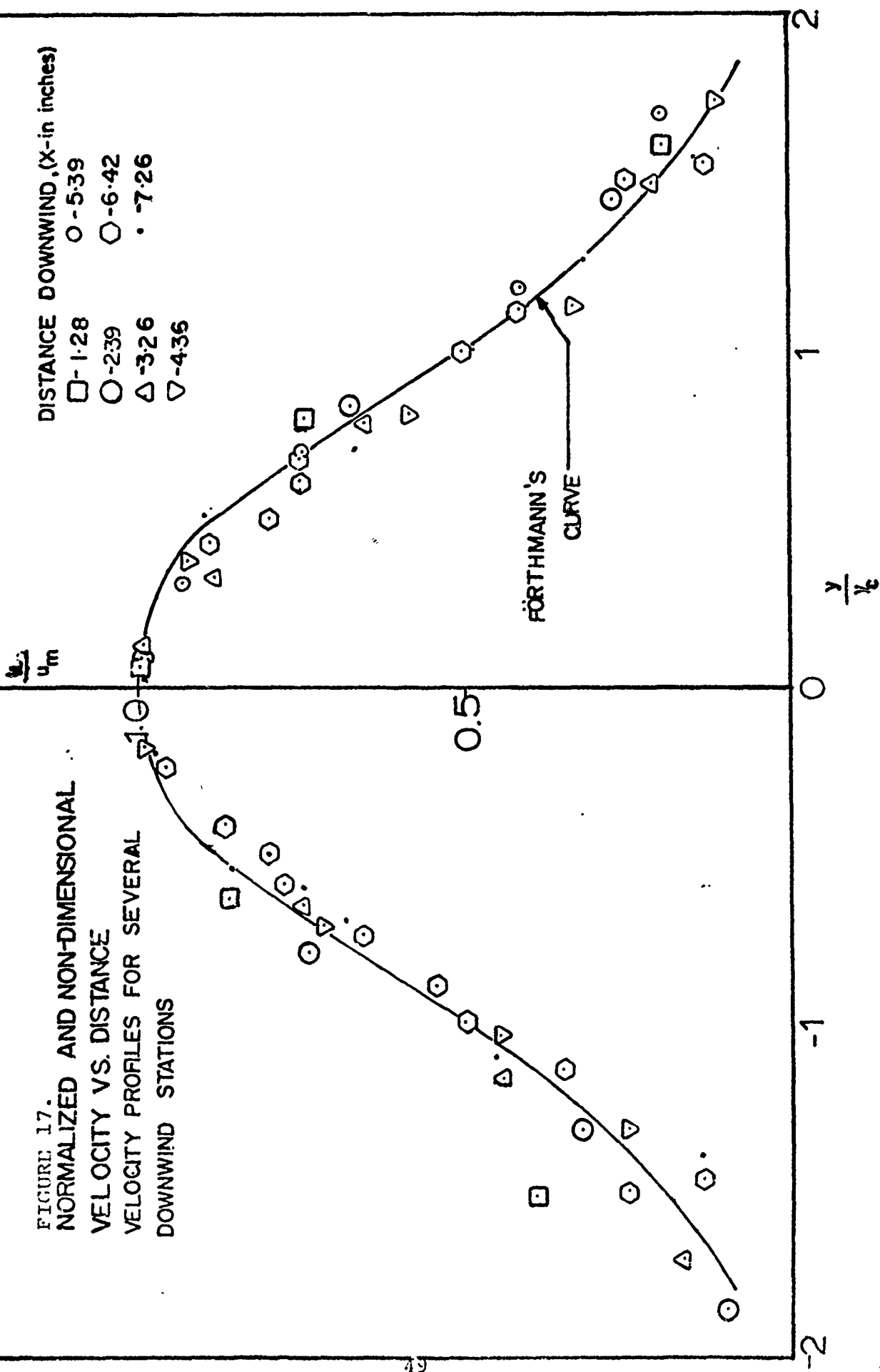

FIGURE 18. PERCENT DEVIATION OF VELOCITY  
VS.  
DISTANCE DOWNSTREAM

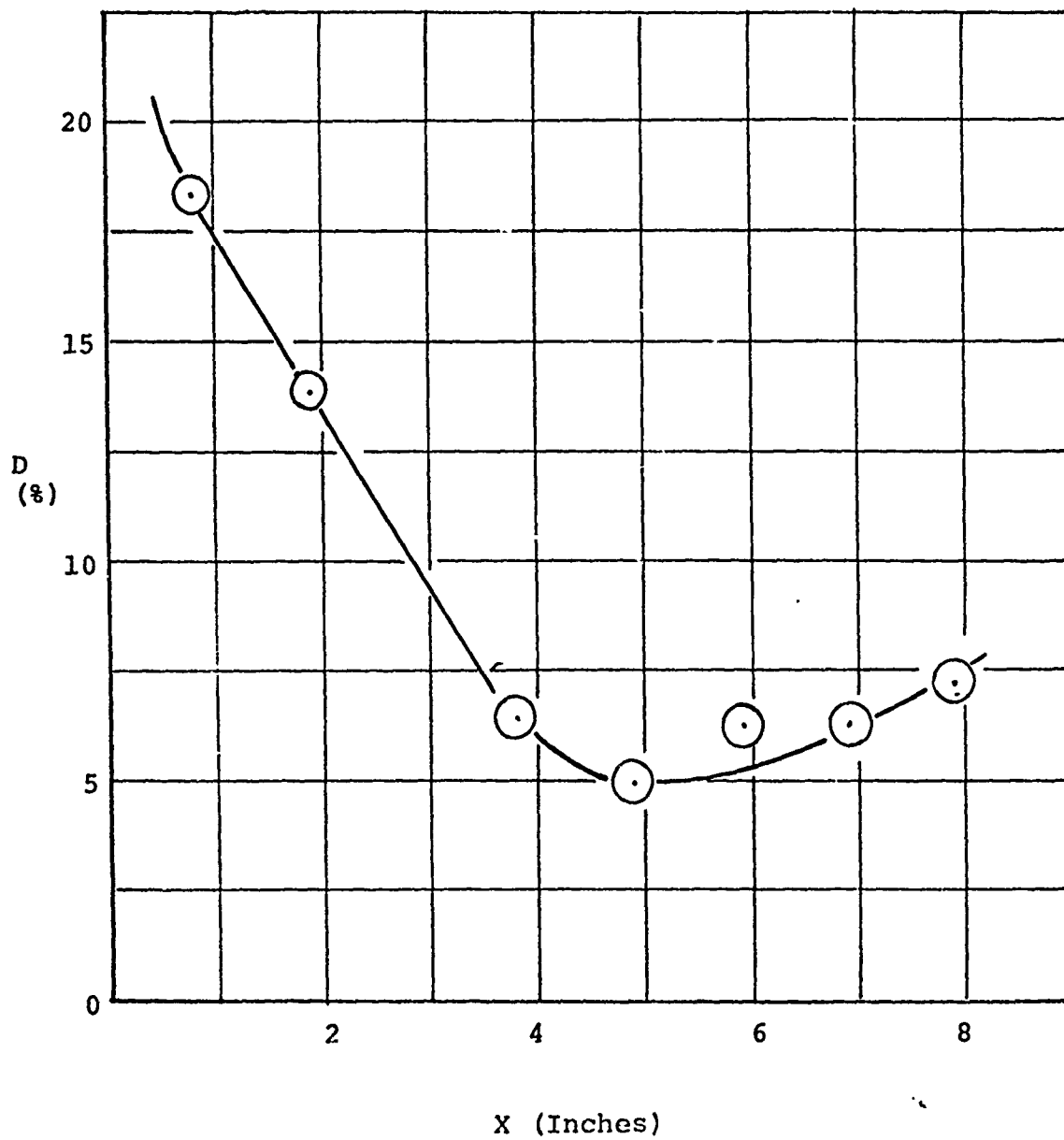
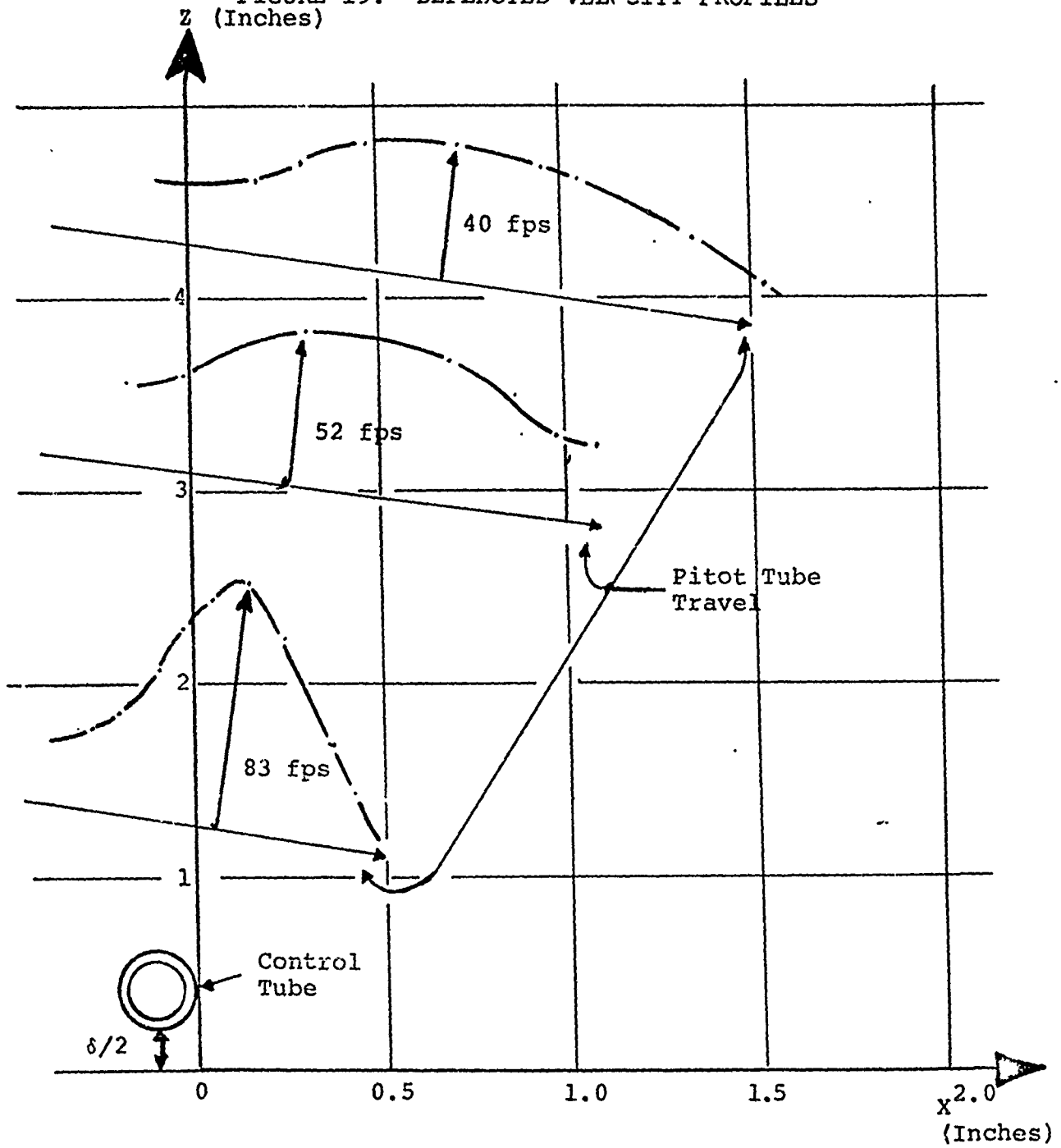

FIGURE 19. DEFLECTED VELOCITY PROFILES



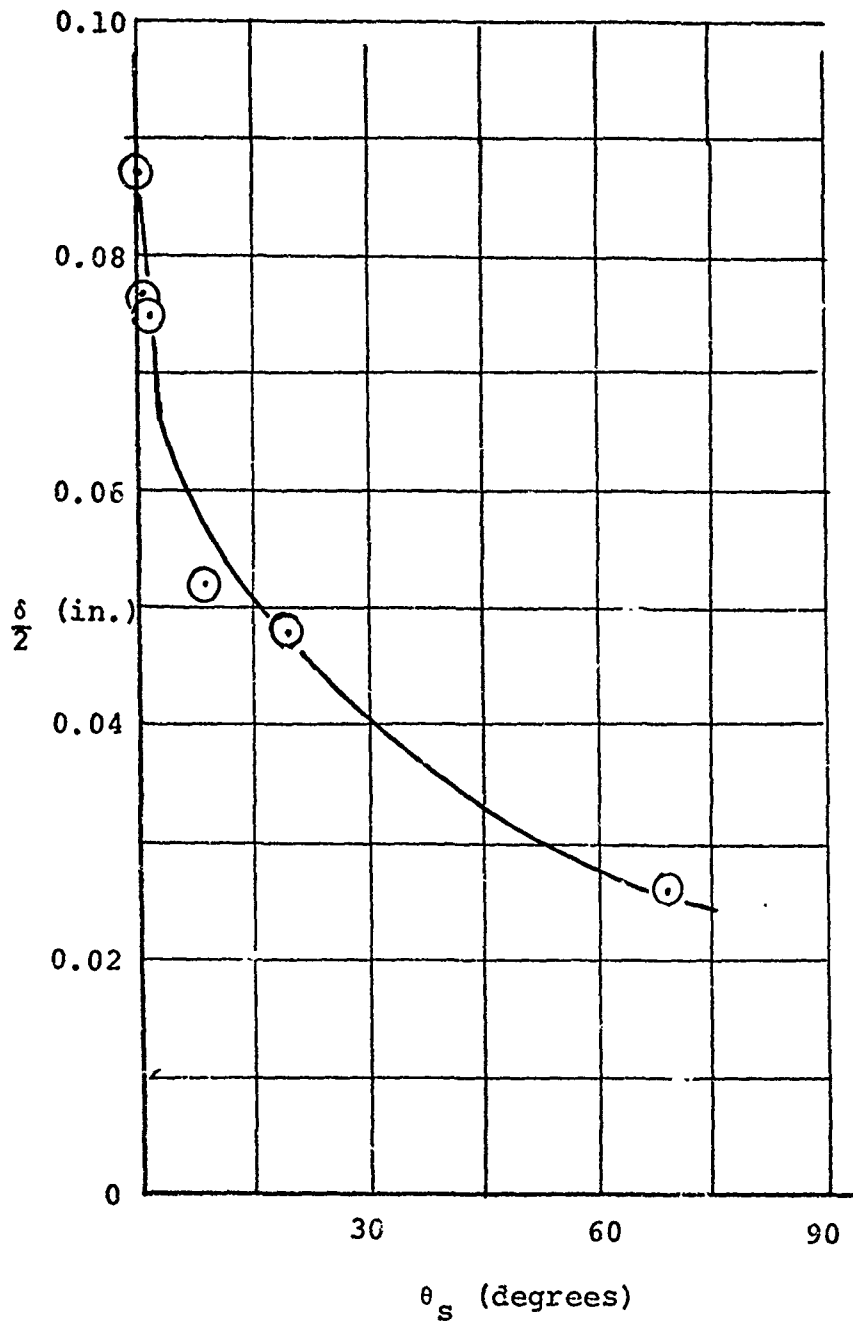

FIGURE 20. JET DEFLECTION ANGLE SENSITIVITY TO CONTROL TUBE MOVEMENT

FIGURE 21. JET DEFLECTION  
VS  
MAIN TUBE ROTATION

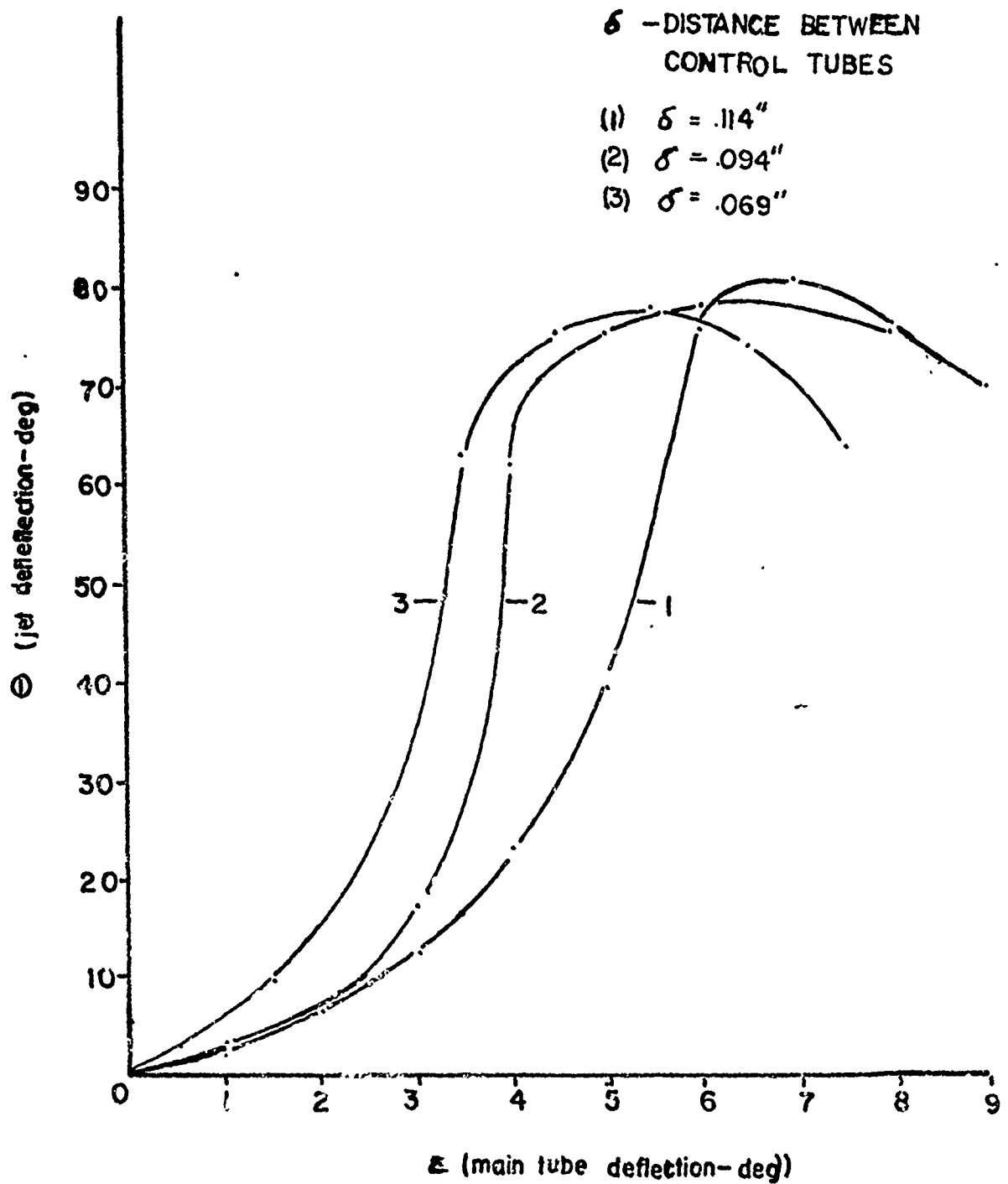
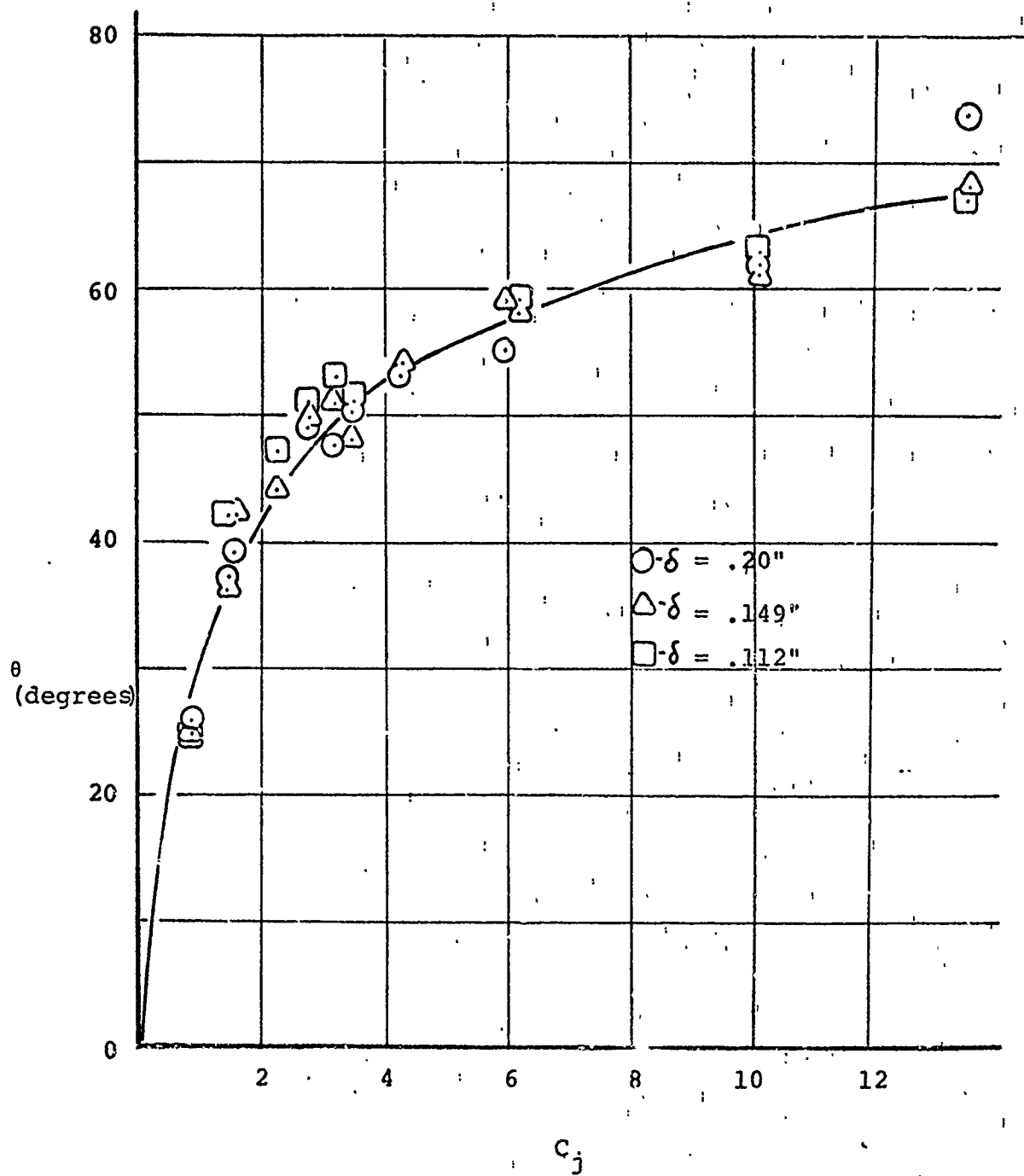

FIGURE 22. JET DEFLECTION VS. JET MOMENTUM COEFFICIENT



P (PSIG)	8 (Inches)	$F_x$ (lbs)	$F_z$ (lbs)	$\eta$ (%)	$F_{zt}$ (lbs)	$\eta_t$ (%)	$\theta_s$ (deg)
20	.19	0.282	0.105	37	—	—	—
30	.19	0.488	0.241	40	0.260	53	71
40	.19	0.735	0.342	46.5	0.389	53	71
50	.19	1.027	0.500	48.6	—	—	—

FIGURE 23. BALANCE DATA

FIGURE 24. GROUND EFFECT ON LIFT

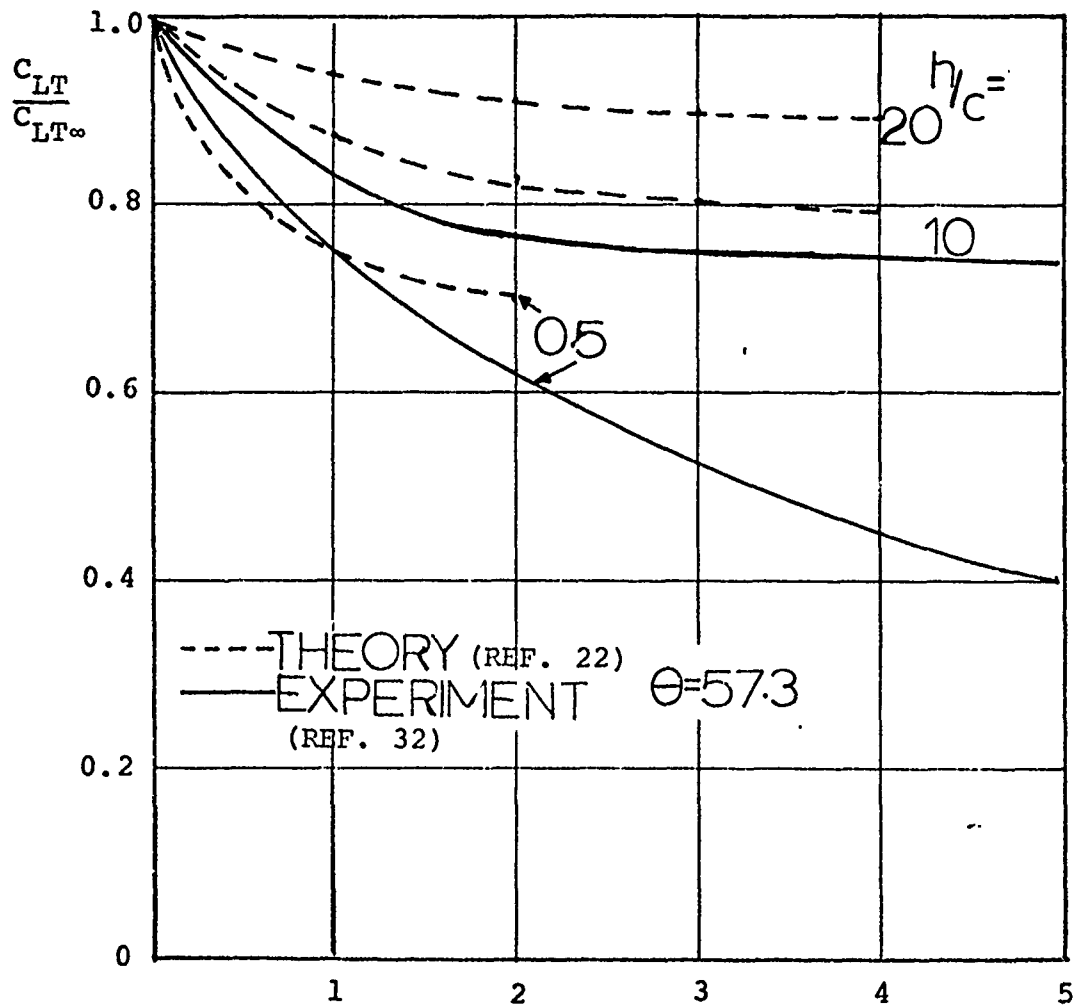

FIGURE 25. THE SEPARATION BUBBLE: A CHARACTERISTIC OF THE JET-FLAP (REF. 12)

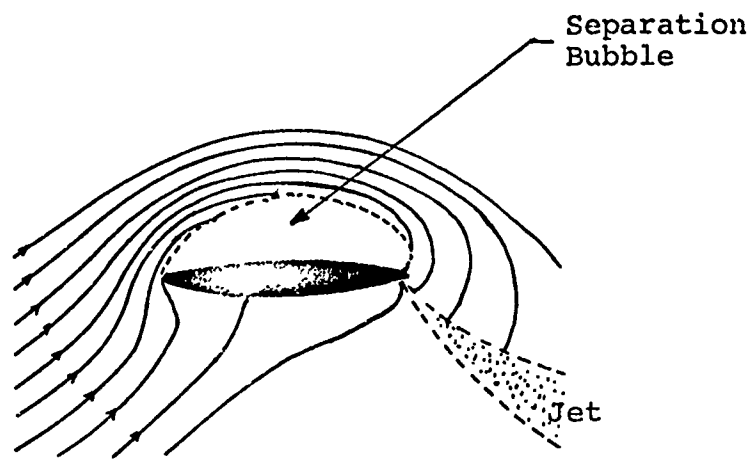

FIGURE 26. PHOTOGRAPHS OF THE SMOKE FLOW  
( $\delta = .2''$  and  $\theta = 84^\circ$ )

Reproduced from  
best available copy.

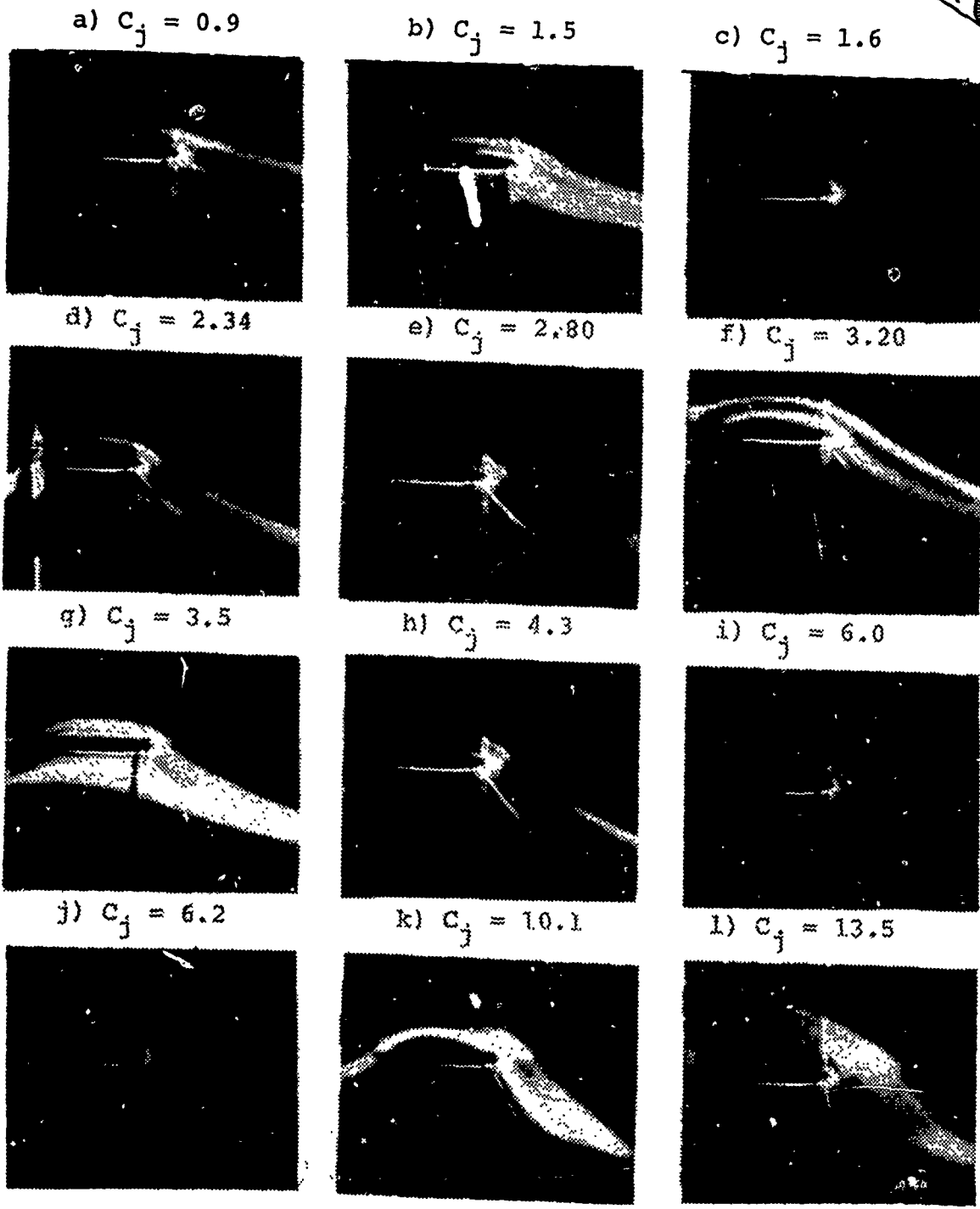
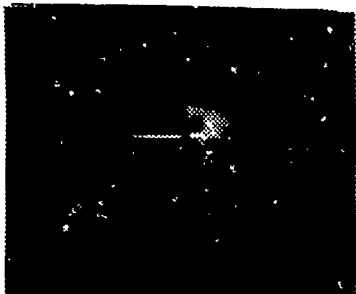

FIGURE 27. PHOTOGRAPHS OF THE SMOKE FLOW

( $\delta = .149''$  and  $\theta_s = 84^\circ$ )

a)  $C_j = 0.9$



b)  $C_j = 1.5$



c)  $C_j = 1.6$



d)  $C_j = 2.34$

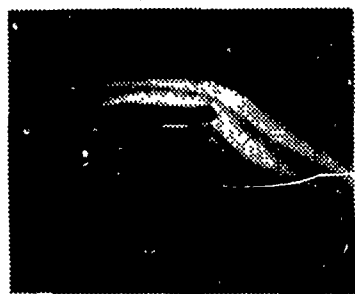

e)  $C_j = 2.80$

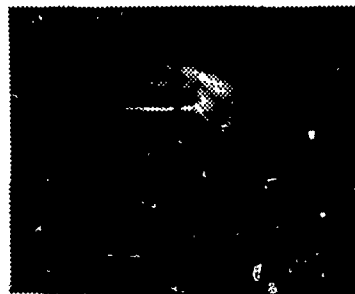

f)  $C_j = 3.20$

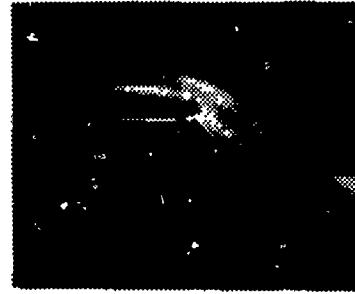

g)  $C_j = 3.5$

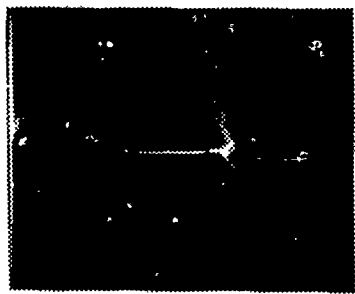

h)  $C_j = 4.3$

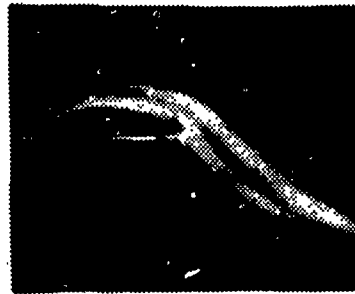

i)  $C_j = 6.0$



j)  $C_j = 6.2$

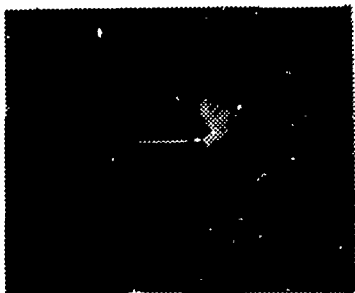

k)  $C_j = 10.1$

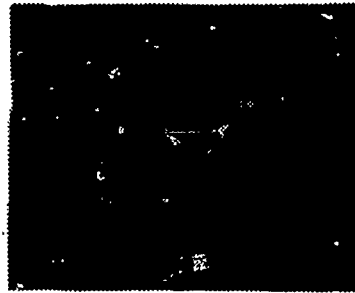

l)  $C_j = 13.5$

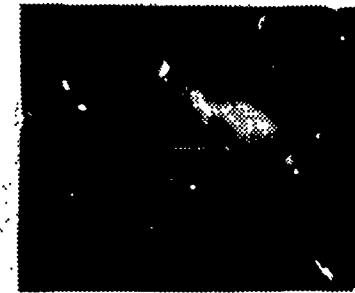

FIGURE 28. PHOTOGRAPHS OF THE SMOKE FLOW

( $\delta = .116''$  and  $\theta_s = 84^\circ$ )

a)  $C_j = 0.9$



b)  $C_j = 1.5$

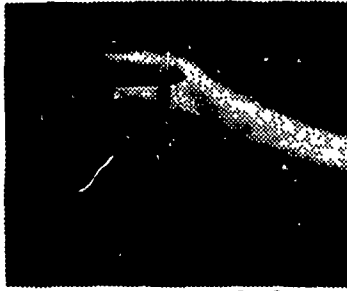

c)  $C_j = 1.6$

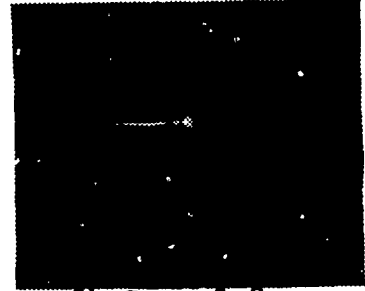

d)  $C_j = 2.3$



e)  $C_j = 2.8$



f)  $C_j = 3.2$

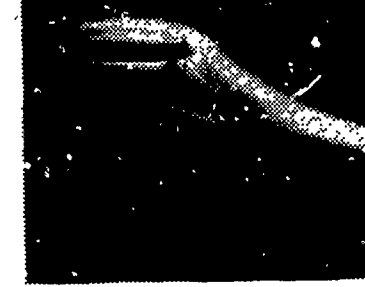

g)  $C_j = 3.5$

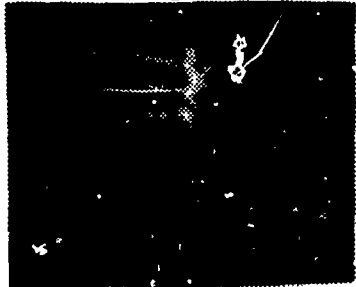

h)  $C_j = 4.3$

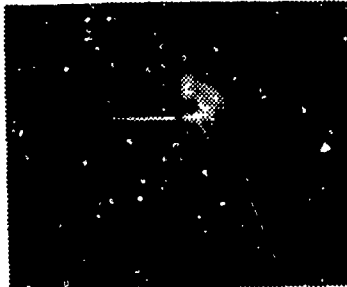

i)  $C_j = 6.0$



j)  $C_j = 6.2$

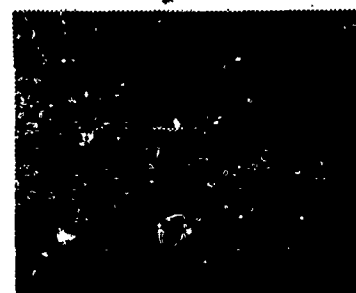

k)  $C_j = 10.1$

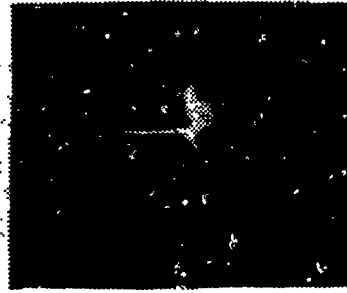

l)  $C_j = 13.5$



FIGURE 29. PHOTOGRAPHS OF THE SMOKE FLOW

( $\delta = .2''$ )

$\theta_s = 35^\circ$

$\theta_s = 50^\circ$

Reproduced from  
best available copy.

a)  $C_j = 0.9$

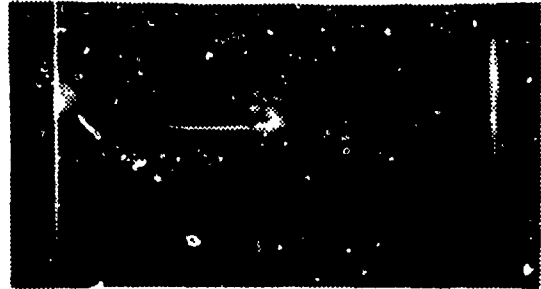
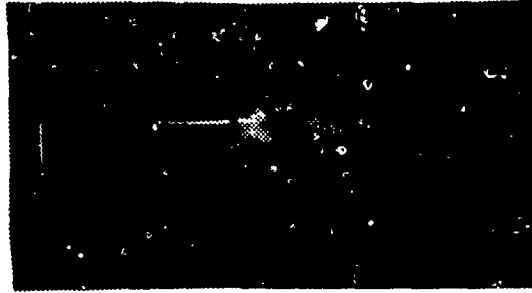

b)  $C_j = 1.5$

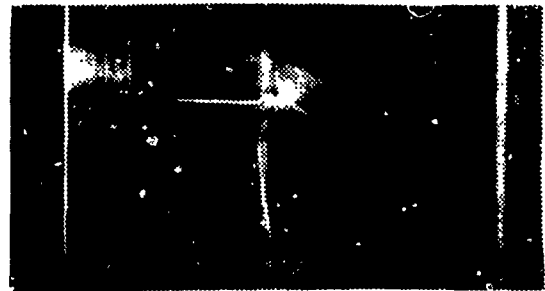
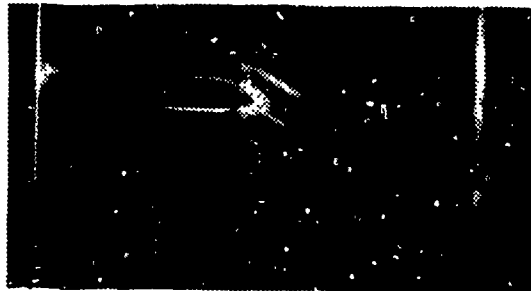

c)  $C_j = 1.6$

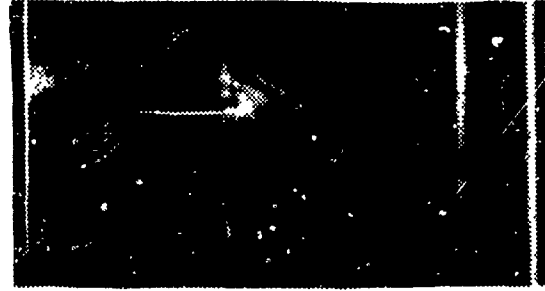
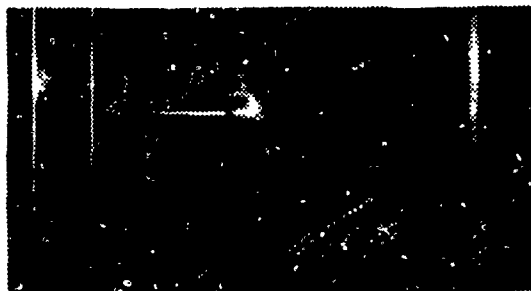

d)  $C_j = 3.2$

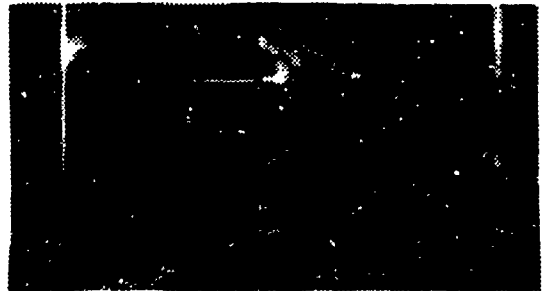

FIGURE 30. PHOTOGRAPHS OF THE SMOKE FLOW

( $\delta = .149''$ )

$\theta_s = 70^\circ$

$\theta_s = 50^\circ$

a)  $C_j = 0.9$

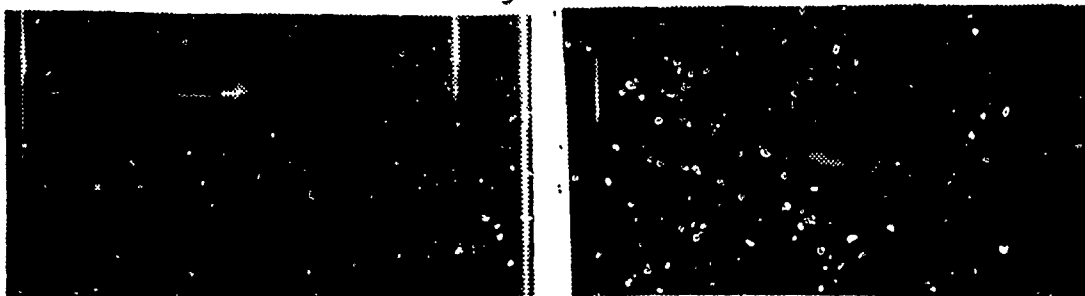

b)  $C_j = 1.5$

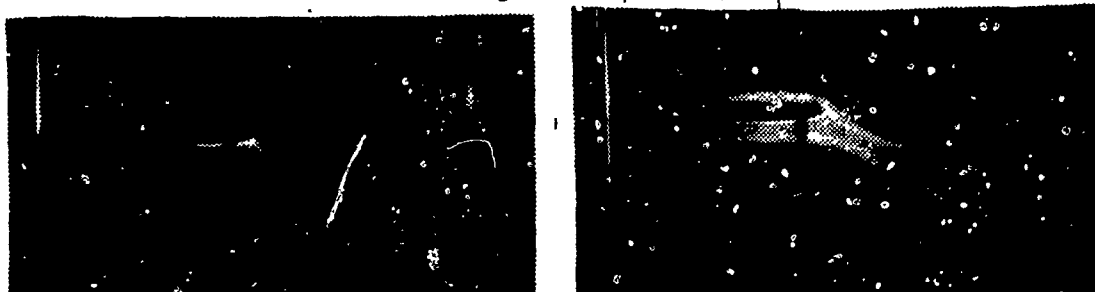

c)  $C_j = 1.6$

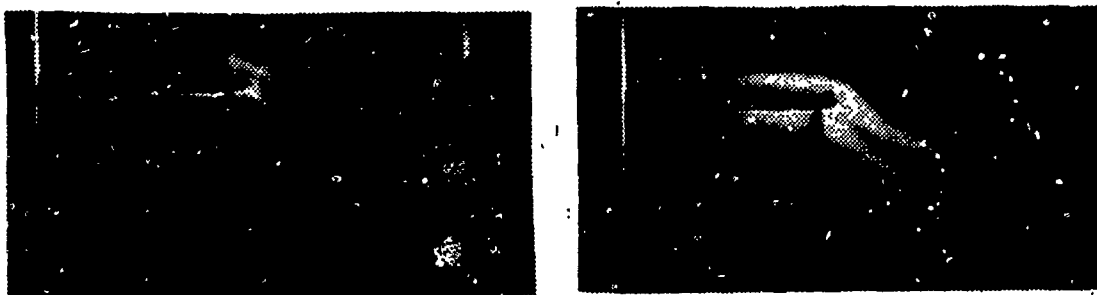

d)  $C_j = 3.2$



FIGURE 31. PHOTOGRAPHS OF THE SMOKE FLOW

( $\delta = .116''$ )

$\theta_s = 45^\circ$

$\theta_s = 65^\circ$

a)  $C_j = 0.9$

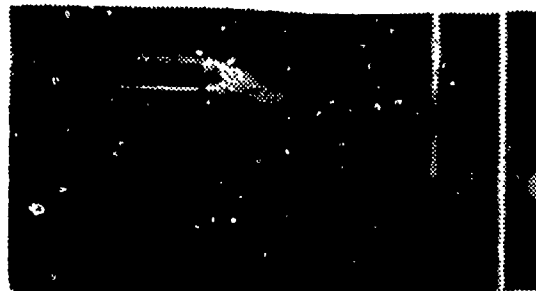
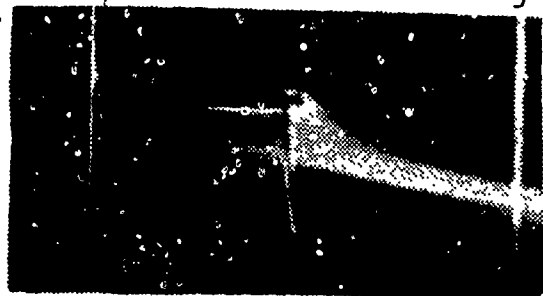

b)  $C_j = 1.5$

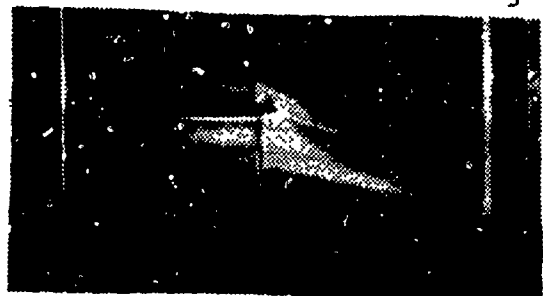

c)  $C_j = 1.6$

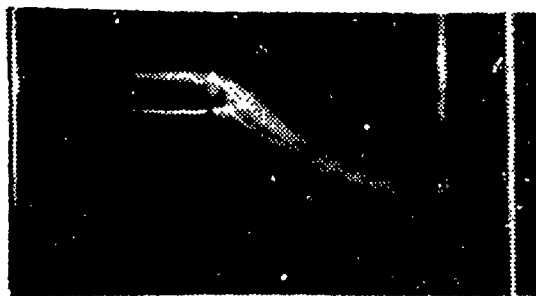
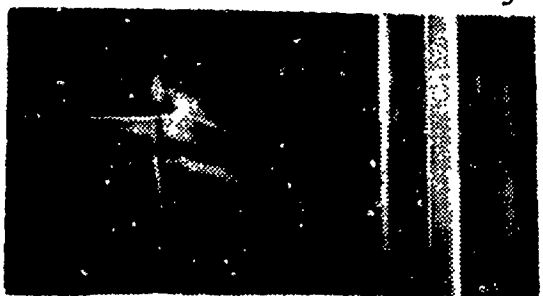

d)  $C_j = 3.2$

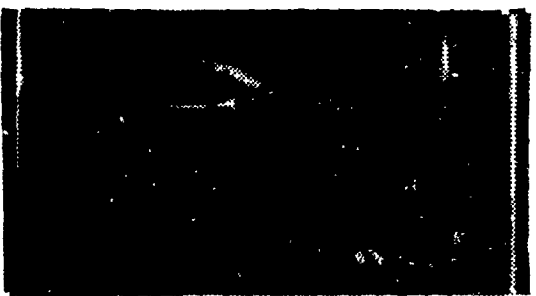

## BIBLIOGRAPHY

1. Abbott and Von Doenhoff, Theory of Wing Sections, p. 320, McGraw-Hill, 1949.
2. Abramovitch, G. N., The Theory of Turbulent Jets, Chapter I, Massachusetts Institute of Technology, 1930.
3. Bailey, A. B., Use of the Coanda Effect for the Deflection of Jet Sheets over Smoothly Curved Surfaces, Part I UTIA Technical Note, No. 49, 1961.
4. Bailey, R. G. and Hammer, Helicopter Application Studies of the Variable Deflection Thruster Jet Flap, Honeywell Document No. 12153-FRI(R), Nov. 1970.
5. Bamber, I. M., Wind Tunnel Tests on Aerofoil Boundary Layer Control Using a Backward-Opening Slot, NACA Rep. No. 385, 1931.
6. Benner, S. D., Coanda Effect at Deflection Surfaces Widely Separated from the Jet Nozzle, UTIAS TN 78, April 1964.
7. Campbell, John P. and Johnson, Joseph L., Jr., Wind Tunnel Investigation of an External-Flow Jet-Augmented Slotted Flap Suitable for Application to Airplanes with Pod Mounted Jet Engines, NACA TN 3898, 1956.
8. Constant, H., in discussions at the NGTE, Nov. 1952.
9. Cook, A. M. and Aiken, T. N., Low Speed Aerodynamic Characteristics of a Large-Scale SPOL Transport Model with an Augmented Jet Flap, NASA TMX-62017, 1961.
10. Corsiglia, Victor, R. and others, Aerodynamic Characteristics of a Large Scale Model of an Unswept Wing and Augmented Jet Flap, NASA TN D-4610, June 1968.
11. Costello, J. P., Smoke and Helium Bubble Visualization Studies of Incompressible Flow Past a Jet-Flap Airfoil, Masters Thesis, Naval Postgraduate School, Monterey, Ca., June 1972.
12. Davidson, I. M., "The Jet Flap," Journal of the Royal Aeronautic Society, Vol. 60, Jan. 1956.

13. Dimmock, N.A., "Some Early Jet Flap Experiments", The Aero. Quarterly, Vol. VIII, Part 4, Nov. 1957.
14. Dimmock, N.A., An Experimental Introduction to the Jet Flap, NGTE Rep. No. R175, July 1955.
15. Fernholz, H. H., "On the Deflection of Free Jets on Convex Surfaces," DLR, FB 66-21, April 1966.
16. Fottinger, H., "New Tests for the Experimental and Theoretical Treatment of Propeller Problems," 19th Symposium of the German Shipbuilding Society, 1917.
17. Freeman, D. C., Jr. and others, Wind Tunnel Investigation of an External Flow Jet-Flap Transport Configuration Having Inboard Pod-Mounted Engines, NASA TN D-7004, 1970.
18. Gates, M. F., Static Lift Characteristics of Jet-Slots - A Clarifying Study of the External Ejector, Hiller Aircraft Corporation, Rep. No. ARD-213, Oct. 1958.
19. Glauert, M. B., "The Wall Jet", Journal of Fluid Mechanics, Vol. I, Dec. 1956.
20. Grantham, W. D. and others, Simulator Study of Flight Characteristics of a Jet-Flap STOL Transport Airplane During Approach and Landing, NASA TN D-6225, 1971.
21. Hagedorn, H. and Ruden P., Wind Tunnel Investigations of a Wing with Junkers Slotted Flap and the Effect of Blowing through the Trailing Edge of the Main Surface over the Flap, Report by the "Institut fur Aero-Mechanik und Flugtechnik der Techn." Hochschule Hannover, LGL Bericht A64. Available as R.A.E. Translation No. 422, Dec. 1953.
22. Jacobs, W. F., and Paterson, J. H., "The Jet Flapped Wing in Two- and Three-Dimensional Flow", I.A.S. Meeting, Preprint No. 791, Jan. 1958.
23. Jacobs, W., "New Theoretical Investigations of the Jet Flap in Two-Dimensional Flow", Z. F. Flugwiss, Vol. 5, No. 9 254-259, 1957.
24. Jacobs, W. F., and Platzer, M. F., Airfoil Including Fluidically Controlled Jet Flap, U.S. Patent 3,669,386, 13 June 1972.

25. Johnson, J. L., Jr., Wind Tunnel Investigation at Low Speeds of Flight Characteristics of a Swept-Back-Wing Jet-Transport Airplane Model Equipped with External-Flow Jet-Augmented Flap, NACA TN 4255, 1958.
26. Jugler, Raymond D., Wind Tunnel Investigation of a Four Engine Externally Blowing Jet-Flap STOL Airplane Model, NASA TN D-7034, 1970.
27. Kind, R. J., "A Calculation Method for Circulation Control by Tangential Blowing Around a Bluff Trailing Edge", Aeronautical Quarterly, Vol. XIX, August 1968.
28. Kind and Maull, "An Experimental Investigation of a Low Speed Circulation-Controlled Airfoil," Aeronautical Quarterly, Vol. XIX, May 1968.
29. Korbacher, G. K., "The Coanda Effect at Deflection Surfaces Detached from the Jet Nozzle," Canadian Aeronautics and Space Journal, Jan. 1962.
30. Korbacher, G. K., Performance, Operation and Use of Low Aspect Ratio Jet Flapped Wings, UTIA Review No. 14, May 1960.
31. Korbacher and Sridhar, A Review of the Jet Flap, UTIA Review No. 14, May 1960.
32. Malavard, L. and others, "Theoretical Experimental Investigations of Circulation Control," ONERA Tech. Note, No. 37, June 1956. Translated by Tim Bertoff and D. C. Hazen, Rep. No. 358, July 1956. Princeton University Department of Aeronautical Engineering or Aero Digest, Sept. to Nov. 1956.
33. Mehus, T., An Experimental Investigation into the Shape of Thrust Augmenting Surfaces in Conjunction with Coanda-Deflected Jet Sheets, Part II, UTIAS TN 79, January 1965.
34. Middlebrooks, J. E. and others, The Evolutionary Development and Current Status of the Augmenter Wing Concept, SAE paper, National Aeronautic and Space Engineering and Manufacturing Meeting, Los Angeles, Ca., Oct. 1970.
35. Newman, B. G. and others, Boundary Layer and Flow Control, edited by G. V. Lachman, Vol. I, Pergamon Press, 1961.

36. Pope, A., Wind Tunnel Testing, 2nd Edition, John Wiley, New York, 1954.
37. Ringleb, F. O., The Three Dimensional Smoke Tunnel of the Naval Air Engineering Laboratory in Philadelphia, Pennsylvania, Rep. NAEL-ENG-6818, 10 July 1961.
38. Roderick, W. E. B., Use of the Coanda Effect for the Deflection of Jet Sheets over Smoothly Curved Surfaces, UTIA Tn 51, Sept. 1961.
39. Sawyer, R. A., "Two Dimensional Reattaching Jet Flows Including the Effects of Curvature on Entrainment", Journal of Fluid Mechanics, Vol. 17, May 1963.
40. Schlichting, H., Boundary Layer Theory, Chap. XXIII, McGraw-Hill, 4th Ed., 1960.
41. Simmons, J. and Platzler, "Experimental Investigation of Incompressible Flow Past Airfoils with Oscillating Jet Flaps," Journal of Aircraft, Vol. 8, No. 8, Aug. 1971.
42. Squire, H. B., "Jet Flow and Its Effect on Aircraft", Aircraft Engineering, 22, 1950.
43. Stratford, B.S., "Early Thoughts on the Jet-Flap," Aero. Quarterly, Vol. VII, Part 1, Feb. 1956.
44. Von Glahn, Uwe H., Use of the Coanda Effect for Jet Deflection and Vertical Lift with Multi-Flat-Plate Deflection Surfaces, NACA TN 4377, Sept. 1958.
45. Von Glahn, Uwe H., Use of the Coanda Effect for Obtaining Jet Deflection and Lift with a Single Flat-Plate Deflection Surface, NACA TN 4272, June 1958.
46. Wick, B. H., and Kuhn, R. E., "Turbofan STOL Research at NASA", Astronautics and Aeronautics, Vol, 9, No. 5, p. 24-50, May, 1971.
47. Whittley, D. C., The Augmentor-Wing Research Program: Past, Present and Future, AIAA Paper No. 67-741, Tenth Anglo-American Aeronautical Conference, Los Angeles, Ca., Oct. 1967.
48. Woods, L. C., "On Thrust Due to an Air Jet Flowing from a Wing Placed in a Wind Tunnel," Journal of Fluid Mechanics, Vol. 1, Part 1, May 1956.
49. Yuan and others, Research on Elliptical Airfoil with Jet Circulation Control, Department of Aerospace Engineering, University of Texas, P.U.C. N00014-67-A0126 for Office of Naval Research.