

AD-756 199

**NOTES ON PROVING RINGS AND FRAMES FOR
SOIL TESTING EQUIPMENT**

Mikael J. Hvorslev

**Army Engineer Waterways Experiment Station
Vicksburg, Mississippi**

March 1972

DISTRIBUTED BY:

NTIS

**National Technical Information Service
U. S. DEPARTMENT OF COMMERCE
5285 Port Royal Road, Springfield Va. 22151**

AD756199



MISCELLANEOUS PAPER S-72-9

NOTES ON PROVING RINGS AND FRAMES FOR SOIL TESTING EQUIPMENT

by

M. J. Hvorslev

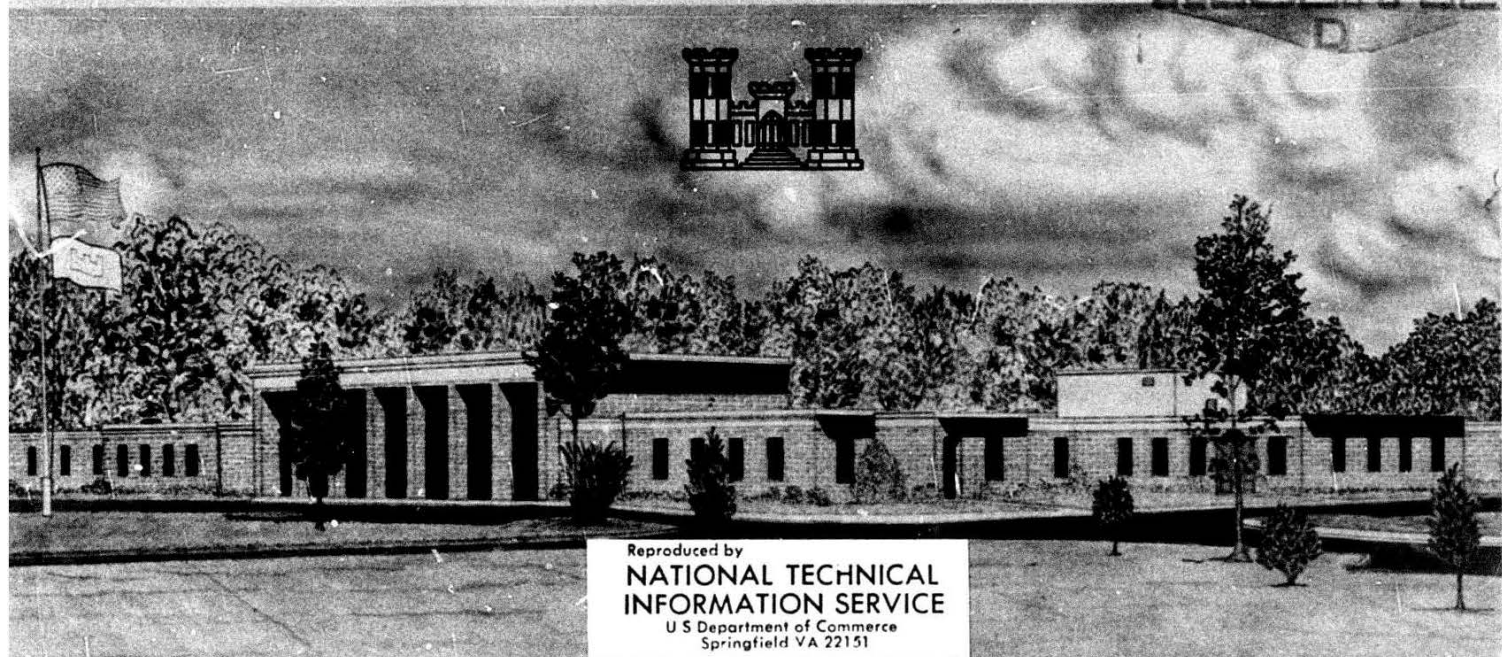

Reproduced by
**NATIONAL TECHNICAL
INFORMATION SERVICE**
U S Department of Commerce
Springfield VA 22151

March 1972

Sponsored by **Office, Chief of Engineers, U. S. Army**

Conducted by **U. S. Army Engineer Waterways Experiment Station, Vicksburg, Mississippi**

APPROVED FOR PUBLIC RELEASE; DISTRIBUTION UNLIMITED

50
R

Unclassified

Security Classification

DOCUMENT CONTROL DATA - R & D		
<i>(Security classification of title, body of abstract and indexing annotation must be entered when the overall report is classified)</i>		
1. ORIGINATING ACTIVITY (Corporate author) U. S. Army Engineer Waterways Experiment Station Vicksburg, Mississippi		2a. REPORT SECURITY CLASSIFICATION Unclassified
		2b. GROUP
3. REPORT TITLE NOTES ON PROVING RINGS AND FRAMES FOR SOIL TESTING EQUIPMENT		
4. DESCRIPTIVE NOTES (Type of report and inclusive dates) Final report		
5. AUTHOR(S) (First name, middle initial, last name) Mikael J. Hvorslev		
6. REPORT DATE March 1972	7a. TOTAL NO. OF PAGES 46	7b. NO. OF REFS 5
8a. CONTRACT OR GRANT NO.	8b. ORIGINATOR'S REPORT NUMBER(S) Miscellaneous Paper S-72-9	
8c. PROJECT NO.		
8d.	8d. OTHER REPORT NO(S) (Any other numbers that may be assigned this report)	
8e.		
9. DISTRIBUTION STATEMENT Approved for public release; distribution unlimited.		
11. SUPPLEMENTARY NOTES Details of illustrations in this document may be better		12. SPONSORING MILITARY ACTIVITY Office, Chief of Engineers Washington, D. C.
13. ABSTRACT Classified on policy This report presents data on the design, construction, and calibration of various types of proving rings and frames used for determination and direct readout of forces or loads in laboratory and field tests on soils and other relatively weak materials. The first part of the report presents equations and diagrams for determination of deflections and moments in thin circular rings, ring segments with bosses, elliptical rings, flattened rings, rectangular proving frames with thin or thick end sections, and compound cantilevers. Some of these equations can be found in handbooks and textbooks, but other equations are not readily available and were developed by applying standard methods of the theory of elasticity to relatively thin structures. The second part of the report deals with the influence of several secondary factors, such as large deformations which can cause appreciable curvature of the calibration diagrams. Rigorous equations for thick rings yield data on corrections for relatively thick devices. Empirical data on fillets and stress concentrations are presented, and the approximate stiffening effect of fillets is estimated by use of a simplified theory in which only angular deflections caused by moments are considered. The influence of misalignment, creep and hysteresis, and temperature variations is discussed briefly. The last two parts of the report present examples of single and compound proving rings and frames proposed for use or actually used in testing equipment. General design procedures using the basic equations are proposed, and data are presented on suitable materials, including recent alloy steels capable of age or precipitation hardening, which eliminates the distortion often caused by heat treatment and quenching of other steels. The final sections deal with rough calibration before hardening and final machining and corrections of dimensions if needed, which are followed by repetitive loading to slightly above the rated capacity before the final calibration in order to decrease the effects of hysteresis and creep and the possibility of zero shifts.		

DD FORM 1473

REPLACES DD FORM 1473, 1 JAN 64, WHICH IS OBSOLETE FOR ARMY USE.

Unclassified

Security Classification

IA

Unclassified
Security Classification

14. KEY WORDS	LINK A		LINK B		LINK C	
	ROLE	WT	ROLE	WT	ROLE	WT
Frames Proving rings Soil mechanics instruments and equipment						

Unclassified
Security Classification

Ib



MISCELLANEOUS PAPER S-72-9

NOTES ON PROVING RINGS AND FRAMES FOR SOIL TESTING EQUIPMENT

by

M. J. Hvorslev



March 1972

Sponsored by Office, Chief of Engineers, U. S. Army

Conducted by U. S. Army Engineer Waterways Experiment Station, Vicksburg, Mississippi

ARMY-MRC VICKSBURG, MISS

11

APPROVED FOR PUBLIC RELEASE: DISTRIBUTION UNLIMITED

THE CONTENTS OF THIS REPORT ARE NOT TO
BE USED FOR ADVERTISING, PUBLICATION, OR
PROMOTIONAL PURPOSES. CITATION OF TRADE
NAMES DOES NOT CONSTITUTE AN OFFICIAL
ENDORSEMENT OR APPROVAL OF THE USE OF
SUCH COMMERCIAL PRODUCTS.

Preceding page blank

Foreword

Preparation and publication of this report were accomplished as a part of Engineering Study (ES) 537, "Special Studies for Civil Works Soils Problems," assigned by the Chief of Engineers to the U. S. Army Engineer Waterways Experiment Station (WES).

The report was prepared by Dr. M. Juul Hvorslev, Consultant to the Soils Division, under the general supervision of Mr. J. P. Sale, Chief, Soils Division. To prepare this report, Dr. Hvorslev used much of the data that he had compiled and analyzed over a period of many years.

Director of WES during the preparation of this report was COL Ernest D. Peixotto, CE. Technical Director was Mr. Fred R. Brown.

Preceding page blank

Contents

	<u>Page</u>
Foreword.....	v
Notations.....	ix
Conversion Factors, British to Metric Units of Measurement...	xiii
Summary.....	xv
Introduction.....	1
Moments and Deflections of Thin Devices.....	2
Thin circular rings.....	2
Thin elliptical rings.....	3
Thin flattened rings.....	4
Thin rectangular frames.....	4
Frames with thick ends.....	4
Composite cantilever.....	5
Influence of Secondary Factors.....	5
Influence of large deflections of a circular ring.....	6
Influence of thickness and curvature.....	8
Influence of fillets.....	8
Minor deviations.....	9
Examples of Proving Rings and Frames.....	11
Circular proving rings.....	11
Flattened proving rings.....	12
Proving frames.....	13
Compound proving rings and frames.....	14
Design and Construction.....	17
Materials.....	17
Design procedure.....	18
Construction and calibration.....	20
Literature Cited.....	23
Figures 1-17	

Notations

Some of the following symbols have more than one definition because they are found in different but commonly used equations:

a	Points on a horizontal line; also, semimajor axis of ellipse
b	Points on a vertical line; also, semiminor axis of ellipse
B	Width of section
c	Width of boss (fig. 1-B); also, point on cantilever (fig. 2-C)
C	Calibration constant
C_o	Theoretical calibration factor (fig. 5)
C'	Actual calibration factor (fig. 5)
D	Diameter of circle
e	Eccentricity of ellipse, $e = \sqrt{1 - k^2}$ (fig. 1-C); also, corrected radius of thick ring (fig. 6)
E	Young's modulus of elasticity
$E(\alpha)$	Elliptical integral (fig. 1-C)
F_x	Deflection factor, general
F_a, F_b	Deflection factors for points a and b
H	Height of frame, elliptical or flat ring
I	Moment of inertia, $B \cdot t^3 / 12$
k	Height over length ratio, H/L , b/a
k'	Weighted height-length ratio (fig. 2-B)
K_δ	See paragraph 35
$K(\alpha)$	Elliptical integral (fig. 1-C)
K_σ	See paragraph 36
ln	Natural logarithm

L	Length or span; also, subscripts for cantilever (fig. 2-C)
m	Coefficient; $m = 1 + (t_o/R)$ (fig. 8)
M	Moment, general
M_a, M_b	Moments at points a and b
n	Thickness ratio, $n = t/R$
N	Coefficient or ratio defined in fig. 1-C
N_x	Moment factor, general
N_a, N_b	Moment factors at points a and b
P	Point load on ring or frame
R	Radius of ring or fillet
t	Thickness, general
t_o	Constant thickness (fig. 8)
t_a, t_b	Thickness of vertical and horizontal sides of frame
Z	Section modulus; $B \cdot t^2 / 6$
α	Angle defined in fig. 1-C
δ	Deflection, general or theoretical for thin ring
δ'	Actual or final deflection of thin ring (fig. 5)
δ'_a	Actual or final deflection of thin ring at point a
δ'_b	Actual or final deflection of thin ring at point b
δ'_c	Actual or final deflection of thin ring at point c
$\bar{\delta}$	Deflection obtained by use of thick ring equations
$\bar{\delta}_a$	Deflections obtained at point a by use of thick ring equations
$\bar{\delta}_b$	Deflections obtained at point b by use of thick ring equations
$\bar{\delta}_c$	Deflections obtained at point c by use of thick ring equations

δ_a	Deflection at point a
δ_b	Deflection at point b
δ_c	Deflection at point c
θ	Half angle of segmented ring (fig. 1-B)
λ_e	Equivalent length of fillet (fig. 8)
λ_s	Effective shortening of span by fillet (fig. 8)
σ	Bending stresses, general
$\bar{\sigma}$	Bending stresses obtained by use of thick ring equations
θ	Variable angle, general

Conversion Factors, British to Metric Units of Measurement

British units of measurement used in this report can be converted to metric units as follows:

<u>Multiply</u>	<u>By</u>	<u>To Obtain</u>
inches	2.54	centimeters
pounds per square inch	0.6894757	newtons per square centimeter
Fahrenheit degrees	5/9	Celsius or Kelvin degrees*

* To obtain Celsius (C) temperature readings from Fahrenheit (F) readings, use the following formula: $C = (5/9)(F - 32)$.
To obtain Kelvin (K) readings, use: $K = (5/9)(F - 32) + 273.15$.

Preceding page blank

Summary

This report presents data on the design, construction, and calibration of various types of proving rings and frames used for determination and direct readout of forces or loads in laboratory and field tests on soils and other relatively weak materials. The first part of the report presents equations and diagrams for determination of deflections and moments in thin circular rings, ring segments with bosses, elliptical rings, flattened rings, rectangular proving frames with thin or thick end sections, and compound cantilevers. Some of these equations can be found in handbooks and textbooks, but other equations are not readily available and were developed by applying standard methods of the theory of elasticity to relatively thin structures. The second part of the report deals with the influence of several secondary factors, such as large deformations which can cause appreciable curvature of the calibration diagrams. Rigorous equations for thick rings yield data on corrections for relatively thick devices. Empirical data on fillets and stress concentrations are presented, and the approximate stiffening effect of fillets is estimated by use of a simplified theory in which only angular deflections caused by moments are considered. The influence of misalignment, creep and hysteresis, and temperature variations is discussed briefly. The last two parts of the report present examples of single and compound proving rings and frames proposed for use or actually used in testing equipment. General design procedures using the basic equations are proposed, and data are presented on suitable materials, including recent alloy steels capable of age or precipitation hardening, which eliminates the distortion often caused by heat treatment and quenching of other steels. The final sections deal with rough calibration before hardening and final machining and corrections of dimensions if needed, which are followed by repetitive loading to slightly above the rated capacity before the final calibration in order to decrease the effects of hysteresis and creep and the possibility of zero shifts.

Preceding page blank

NOTES ON PROVING RINGS AND FRAMES
FOR SOIL TESTING EQUIPMENT

Introduction

1. Data on design, construction, and use of proving rings and frames for measurement of forces or loads in laboratory and field tests on soils have been compiled or developed in the course of many years. A summary of these data is presented in this report. The first part of the report contains equations and diagrams (figs. 1-4) for determination of deflections and moments in proving rings and frames of various types obtained by application of the theory of elasticity to the simplified condition of thin structures. Some of these equations can be found in handbooks and textbooks, but other equations were not readily available and were developed as needed. The influence of secondary factors, such as appreciable deformations and thickness, corner fillets, creep and hysteresis, and temperature changes, are discussed in the second part (figs. 5-8). The third and fourth parts of the report present examples of actual and possible applications of the data in the first two parts (figs. 9-17) and include a discussion of suitable materials for proving rings and frames, machining, special treatment, and final calibration of the equipment. The forces exerted during tests are now often measured by means of commercially available load cells with electrical-resistance strain gages and remote readout and/or recording, but proving rings and frames with mechanical and direct readout are needed or advantageous in many cases.

Moments and Deflections of Thin Devices

Thin circular rings

2. Full circular rings. The formulas shown in fig. 1-A can be found in most civil engineering handbooks and in textbooks on theory of elasticity. There is symmetry with respect to both the vertical and the horizontal axes. The normal force at points a is $P/2$, whereas this force at points b is zero. The influence of large deflections and of the thickness of the ring is discussed in paragraphs 12 and 13 and shown in figs. 5 and 6.

3. Circular ring segments. Proving rings and frames are often provided with bosses that facilitate the application of forces and the fastening of the ring or frame to other parts of the testing equipment. The only active parts of the ring are those between the bosses, or portions "bab" in fig. 1-B. The formulas in fig. 1-B are derived in the same manner and are subject to the same limitation as those for a full circular ring. Circular fillets are nearly always used at the junctions of the ring sections and the bosses in order to reduce the stress concentration, but such fillets also reduce the effective length of the thin circular segments.

4. Method of analysis. The principles of the method used to determine the moments and deflections or changes in horizontal and vertical diameters, δ_a and δ_b , as shown in figs. 1-A and 1-B, can be summarized as follows. Due to symmetry, the angular deflections are zero at points a and b, and the normal resultant internal force at points a is $P/2$. Considering the upper right quadrant and a coordinate system with the origin at the center (see fig. 1-B), the

coordinates and moments can be expressed by

$$x = R \cos \alpha \quad (1)$$

$$y = R \sin \alpha \quad (2)$$

$$M = M_a + \frac{1}{2} P (R - x) \quad (3)$$

M_a is determined by the condition of zero angular deflection at b , or

$$\int_0^\theta \frac{M ds}{E I} = 0 \quad \text{and} \quad ds = R d\alpha \quad (4)$$

The deflection at points a , or changes in the horizontal diameter, δ_a ,

$$\delta_a = 2 \int_0^\theta \frac{M (R x \sin \theta - y) ds}{E I} \quad (5)$$

and the change in the vertical diameter, δ_b , is

$$\delta_b = 2 \int_0^\theta \frac{M \left(x - \frac{1}{2} s \right) ds}{E I} \quad (6)$$

These integrals yield the equations shown in fig. 1-B. The equations in fig. 1-A are obtained for $\theta = \pi/2$. The same general method is also used for other thin devices.

Thin elliptical rings

5. Equations similar to those in paragraph 4 yield expressions for moments in and deflections of a thin elliptical ring (see fig. 1-C). As could be expected, these expressions contain elliptical integrals, $E(\alpha)$ and $K(\alpha)$. The semimajor axis is a , and the semiminor axis is b .

The evaluation of these equations is facilitated by the diagrams shown in fig. 3, using the variables $L = 2a$ and $H = 2b$. These formulas and diagrams for deflections of a thin elliptical ring were developed as an aid in determining the true deflections of a circular ring (see fig. 5).

Thin flattened rings

6. Moments and deflections for a flattened ring (fig. 2-A) can be developed by the method described in paragraph 4. The equations shown in fig. 2-A are relatively cumbersome, and evaluation is facilitated by use of the diagrams in fig. 4. A flattened ring is relatively flexible and has a smaller height and much greater lateral stability than a corresponding circular ring, but certain difficulties, which will be discussed later, are encountered in the manufacture of flattened rings.

Thin rectangular frames

7. Moments and deflections of a thin rectangular frame can also be determined by use of the methods discussed in the foregoing paragraphs; however, it is easier to use the moment area method and the condition that moments in the horizontal and vertical arms of the frame must be equal at the corners. The resulting equations are relatively simple. It should be borne in mind that the equation for the vertical deflection, δ_b , represents the change in height of the frame, or the sum of the vertical deflection of the upper and lower horizontal arms of the frame.

Frames with thick ends

8. In some cases, it is desirable for the purpose of machining and final adjustment to use a frame with relatively thick vertical sides

(see fig. 2-C). In these cases, the sidewalls should be thick enough to be considered inflexible, and the horizontal sides should be fully fixed at the vertical sides, so that the deflections can be determined by the simple equation for a fixed beam.

9. The proving rings and frames discussed above are usually provided with bosses to facilitate attachment to the testing equipment. In using the equations, the width of the bosses should be subtracted from the gross horizontal length.

Composite cantilever

10. A cantilever spring is a very simple and compact force-measuring device, but it has the disadvantage that its deflections are very sensitive to slight changes of the point of application of the force. Symmetrical proving rings and frames, on the other hand, are relatively insensitive to such changes. The cantilever spring shown in fig. 2-D is provided with a rigid end section to facilitate definition of the point of force application and of the point corresponding to the measured deflections. Point b is at the end of the flexible section, and its deflection corresponds to application there of the force P and the moment PL_a . The angular deflection at point b is

$\frac{1}{2}(M_a + M_b)L_a/EI$. The deflection at point c is equal to the deflection δ_b plus the angular deflection at b times the distance L_c .

Influence of Secondary Factors

11. Bending stresses corresponding to the moments shown in the aforementioned figures can be determined by the equation $\sigma = M/W$, where the section modulus $W = B t^2/6$ and B is the width and

t the thickness of the section being considered. The equations in the foregoing text and figures are based on the assumptions commonly made for simple structures, such as linear deformation of cross sections in bending. No consideration is given to the influence of large deformations, curvature of elements, fillets in corners, or to deformations caused by normal and shear forces. The influence of some of these factors is illustrated in the following paragraphs for a few special cases. The results serve to point out the reliability of the simple equations, but these equations should not be applied indiscriminately to all devices and conditions.

Influence of large deflections of a circular ring

12. The deflections of a loaded full circular ring constitute an increase of the horizontal axis and a decrease of the vertical axis, so that the ring assumes a shape approximating that of an ellipse. This change in shape causes additional deformations. The initial deformation of a circular ring is shown in fig. 1-A, and is expressed as

$$\delta_b = - \frac{P D^3}{E I} 0.0186 \quad (7)$$

The corresponding vertical deflection for an ellipse, δ'_b , could be computed by use of the equations in fig. 1-C, but the following simpler equation can be obtained empirically from fig. 3 when the ratio of the minor to the major axis, H/L , is close to unity:

$$\delta'_b = - \frac{P (D + t_a)^3}{E I} (0.0116 + 0.0070 k) \quad (8)$$

where k is the ratio of the axes, or

$$k = \frac{D - \delta'_b}{D + \delta'_a} = 1 - \frac{\delta'_a + \delta'_b}{D} \quad (9)$$

considering only the numerical values of the deflections and discarding small terms of higher order. For the same value of the load, these equations yield the ratio between the final and initial vertical deflections

$$\frac{\delta'_b}{\delta_b} = 1 + 2 \frac{\delta'_b}{D} = 1 / \left(1 - 2 \frac{\delta_b}{D} \right) \quad (10)$$

This equation yields the deflection curve that is below the theoretical straight deflection curve shown in the middle portion of fig. 2.

13. The results of a calibration test may be represented graphically by a diagram of load versus deflection, but such a diagram does not clearly show the occurrence of small irregularities or a slight curvature, both of which are shown much more clearly in a curve of calibration factors versus deflections. The initial calibration factor for a circular ring is $C_o = P / \delta_b$, which theoretically should be a constant. The actual or final calibration factor can be obtained by use of equation 10 and $C' = P / \delta'_b$ and is

$$C' = \frac{P \delta_b}{\delta_b \delta'_b} = C_o \left(1 - 2 \frac{\delta_b}{D} \right) \quad (11)$$

which is represented by the lower diagram in fig. 2. Therefore, the actual calibration factor for a circular ring decreases with increasing deflections, as has also been found in calibration tests with proving rings.¹ Changes of the calibration factor with deflections are much smaller for flat proving rings and frames.² These results constitute a warning against replacing a slightly curved load-deflection curve with

a straight line corresponding to a constant calibration factor.

Influence of thickness and curvature

14. It has long been known that the simple stress and deflection equations for a straight beam or a thin ring may yield results too much in error for strongly curved beams or thick rings. Solutions and references on thick rings are presented by Wilson, Tate, and Borkowski.¹ Based on equations and simplification by Timoshenko,³ Wilson, Tate, and Borkowski propose the use of the equations shown in fig. 6 for determining maximum stresses and vertical deflections of a thick ring. Corresponding equations for a thin ring are obtained by dividing the moment equations shown in fig. 1-A by $Z = B t^2/6$ and inserting $I = B t^3/12$ into the deflection equation. The ratios between the stresses, σ'/σ , and the vertical deflections, δ'/δ , obtained by use of equations for thick rings versus those for thin rings, are shown in analytical and graphical forms in fig. 6, using the thickness ratio $n = (t/R)$ and the approximations for e or e/R proposed by Timoshenko. The equation for thin rings yields too small values of stresses and deflections, and the deviations are appreciable when the thickness ratio, n , exceeds 0.2. Similar investigations have not yet been made for the limits of reliability of the equations for flattened rings and frames shown in fig. 2.

Influence of fillets

15. Reentrant corners in mechanical force-measuring devices are usually provided with circular fillets to reduce stress concentrations (fig. 7 and reference 4). A significant increase of stresses can easily be avoided by the use of fillets with adequate radii or radius-thickness ratios. However, a fillet causes a local increase in stiffness that may result in a

significant decrease in angular deflection at the end of the fillet and a corresponding decrease of deflections at the center of the span. Detailed tables of equations and coefficients for determination of moments in haunched beams have been published, but they cannot be used directly for estimating the influence of fillets on the maximum deflections. A partial and simplified solution of this problem is presented in fig. 8.

16. The influence of a fillet on deformations is primarily reflected by the change in angular deflections at the end of the fillet, which easily can be computed when the moment, M , can be considered as constant over the length of the fillet. When the angular deflection at the end of the fillet is equal to that at the end of an equivalent beam with constant thickness, t_0 , and length, λ_e , then this length represents the effective length of the fillet, and $\lambda_s = R - \lambda_e$ is then the shortening effect of a single fillet. That is, the vertical deflections may be computed as for a plate or beam without the fillet and the effective length $L_e = L - n\lambda_e - c$, where n is the number of fillets and c is the length of a central boss. The simplifying assumptions should be borne in mind when using the above-mentioned method and the diagram in fig. 8, which in some cases may yield slightly overestimated values of the shortening effect of the fillets.

Minor deviations

17. Alignment. The various parts of a proving ring or frame should be truly parallel or perpendicular to each other as required by the design so that the load can be applied centrally and normally to the device. Heat treatment should be done before the final machining so that warping and other irregularities can be eliminated or decreased by the machining. Most of the devices discussed in this report are symmetrical with respect to both vertical and horizontal axes and are much less sensitive to minor irregularities than asymmetrical devices. Nevertheless, irregularities

should be removed, insofar as possible, since the magnitude of deviations in load alignment and load indications usually increases with increasing loads. Errors caused by a slight inclination of the applied load have been investigated by Wilson-Tate-Borkowski (1946) and were found to be small but measurable, see fig. 10 in reference 1.

18. Temperature. Deflections of a proving ring or frame for a given load increase slightly with increasing temperature and decrease slightly with decreasing temperature because of changes of the modulus of elasticity and also because of small changes in span. The temperature corrections vary also with the material used and are nearly zero for special isoelastic metals. For the commonly used chrome-nickel alloy steel, the change is about 0.02 percent for each degree Fahrenheit change in temperature (see equation quoted by Wilson-Tate-Borkowski, page 10 of reference 1). This change is so small that it usually can be neglected for force-measuring devices calibrated and used in a laboratory where the temperature is fairly constant, but corrections may have to be considered when force-measuring devices are used outdoors and are subject to great temperature variations.

19. Creep and hysteresis. During calibration the deflections are generally read immediately after load application, but this procedure can seldom be followed during actual testing. The deflection of a proving ring or frame for a given load increases slightly with time because of creep or elastic aftereffect, which also may cause a temporary zero shift upon unloading. For proving rings of alloy steels, these deviations can usually be reduced to less than 0.1 percent of the deflection at design or maximum load. Friction anywhere in the measuring device may produce a large and objectional apparent hysteresis effect, which can and should be eliminated or reduced to tolerable limits for the proving rings and frames described in this report. The basic hysteresis of the material cannot be eliminated,

but for devices of alloy steels the hysteresis effect may be reduced to the same order of magnitude as that of the creep effect by repeated loading and unloading or work hardening before the final calibration.

Examples of Proving Rings and Frames

Circular proving rings

20. The proving ring shown in fig. 9 is of the original type developed for measuring compressive forces in the calibration of other rings and testing equipment. Contact is made with integral outside bosses, whereas smaller inside bosses serve for attachment of a micrometer dial and a vibrating reed for measuring deflections. Such proving rings can also be obtained with outside attachments for measuring tensile forces. These rings are made of chrome-nickel alloy steel, forged, rough machined, heat-treated, and finally ground. It is usually required that the rings have a deflection of not less than 0.040 in. at maximum load, and they are generally calibrated and certified by the National Bureau of Standards. A diagram of calibration factors versus deflections is a straight line, as shown in figs. 5 and 10. The specified accuracy is 0.1 percent of the maximum load for the load interval P_{\max} to $0.2 \times P_{\max}$. For lower loads, the requirement is changed to 0.5 percent of the acting load. The requirements and the corresponding deviation limits for the calibration factors are shown in fig. 10.

21. The above-mentioned certified proving rings are primarily used for calibrating large equipment and are relatively expensive. The costs can be decreased by replacing the integral bosses with welded bosses, using the same material as in the ring for welding in an inactive atmosphere, such as helium or argon. Such bosses are usually machined for attachment

to testing equipment. The cost of proving rings can be further decreased by replacing bosses with clamps (see fig. 11) that are widely used in commercially available testing equipment. Flat clamps, Type A in fig. 11, are objectionable, since they contact the rings along three different lines, causing stresses and deflections of the ring to vary with the tension in the clamping screws. Clamps with a single vertical plane of contact, Type B in fig. 11, are preferable, since the tension in the clamping screws then has a much smaller influence on the calibration factor.

Flattened proving rings

22. The flattened proving ring shown in fig. 12 was made from a strip of spring steel that was annealed and then bent and welded to two bosses, as shown in fig. 13-A. The ring and bosses remained clamped to the spacer or die bar during subsequent rehardening and cooling. Nevertheless, some warping remained after release from the clamps, and the thickness of the ring outside the fillets had, in some places, been reduced a little by the welding flame. Such accidental burning of the ring section proper can be avoided by using preshaped flat steel strips, as shown in fig. 13-B. The flattened proving ring is light, low, and laterally stable; variations of the calibration factor with deflections are much smaller than for a full circular proving ring. However, it is difficult to avoid or rectify some warping during the welding, rehardening, and cooling. One proving ring has been built as shown in fig. 13-A, and in spite of some warping, it had a nearly straight calibration diagram with very little hysteresis.

23. The proving ring in fig. 12 is provided with an arrangement for changing the actual measured deflections until a desired and convenient calibration factor is obtained. The total vertical deflections of the ring are measured when the two knife edges contact the ring in the area opposite

the boss. Rotating the adjustment screw until contacts between the knife edges and the ring are outside the boss causes a reduction of the actual measured deflections. The deflection adjuster is held in central position by a pin that can slide in a hole in the boss. This adjustment equipment is very light, and the friction between the knife edges and the ring and between the center pin and walls of the hole is so small that it cannot be determined because of irregularities in standard deflection dials.

Proving frames

24. Many proving frames have been built at the U. S. Army Engineer Waterways Experiment Station (WES) for both laboratory and field testing equipment. Most of these frames are flat with thick end sections, as shown in fig. 14-A. The thick end sections simplify design and construction (fig. 2-C) and reduce variations of the calibration factor with increasing deflections. In the initial machining, the span may be made slightly shorter than the design span, as indicated by the dashed end circles in fig. 14-A. Before the final machining, the frame is subjected to a preliminary loading test, and the results are used to compute the needed increase in span to obtain the desired deflection. Such a proving frame resembles a flattened proving ring and has the same advantages of small height and lateral stability.

25. Introduction of a deflection adjuster (fig. 14-B) requires an increase of the internal height of the frame. The use of a semicircular form on the inside of the end section then corresponds to relatively large fillets and reduction of the deflections of the frame, as shown at the left in fig. 14-B. In this case, it may be advantageous to use fillets of a more normal size plus a straight middle section of the end wall, as shown at the right in fig. 14-B.

26. For the frames shown in figs. 14-A and 14-B, the force is

transmitted by a yoke, and the deflection dial is outside the frame, which is a convenient arrangement for many types of testing equipment. For other types of design of testing equipment, it would be preferable to have the deflection dial inside the frame. Such an arrangement is shown in fig. 14-C and was developed by the Norwegian Geotechnical Institute (NGI). The moments in and deflections of such a frame may be computed by the equations shown in fig. 2-B. The corners of the frame are rounded inside and outside. The vertical end walls are thicker than the horizontal walls because they have to withstand the same moment as well as a normal force corresponding to the load on the frame. Such a deep frame is more flexible than a flat frame of the same span. Construction of this frame was facilitated by development of a casting procedure for alloy steel that eliminates most of the final machining.

Compound proving rings and frames

27. The relative accuracy of a given proving ring or frame decreases sharply for low loads, perhaps less than 5 to 10 percent of the rated capacity. Proving rings or frames of various capacities are generally available, but for a test specimen of unknown strength it may be difficult to decide which ring or frame to use. Therefore, double-range rings or frames are often used. A frequent specification is that a lower range of 20 to 33 percent of the rated capacity should have a sensitivity that is three to five times as great as that of the upper range. A double range may be obtained by combining rings and/or frames in various ways. A common and commercially available double-range combination of two proving rings is shown in fig. 15. The two rings are held together by the lower screw clamp; the upper screw clamp is attached to the outer ring and supports the central deflection dial. The lower range loads are supported solely by the outer ring, which is designed for the desired

deflections in the lower range. The upper range starts when the underside of the upper clamp touches the inner ring; thereafter the load is carried jointly by the two rings, and the sensitivity in the upper range is a function of the stiffness of both rings.

28. A double-range measuring unit can also be obtained by combining a circular and a flattened proving ring (fig. 16). The flattened proving ring may be replaced by a flat proving frame. Low range loads are transmitted in full to each of the two rings, and the measured deflections are the sum of deflections of both rings. The upper range starts when the load causes closure of the gap above the range spacer in the lower ring. Greater loads will be supported by the circular ring and the range spacer, and the measured deflection in the upper range depends only on the stiffness of the circular ring.

29. Conditions similar to those described in the foregoing paragraph can be obtained by combining two flat proving frames (fig. 17) and placing the deflection dial outside the frames. In the low range, the full load is transmitted to each of the frames, and the measured deflections are the sum of the deflections of the individual frames. At the end of the low range, the gap below the range spacer in the lower frame is closed. Larger loads will be supported by the upper frame and the range spacer, and the measured deflections are only those of the upper frame. Such a force-measuring unit was designed for use in deep penetration tests with rather uncertain limits for both compressive and tensile forces, which are transmitted through the thrust plate. Therefore, the upper frame is provided with a compression overload stop. A tension overload stop is suspended from the thrust plate.

30. Figure 17 exemplifies the above-mentioned relations. In the desired low range, the load may vary from 0 to 1000 kg with a deflection

of 0.0001 in. * for each kilogram of load, or a total deflection of 0.1 in. at 1000-kg load. The load in the upper range may vary from 1000 to 5000 kg, with a deflection of 0.0001 in. for each 5 kilograms of load or a total deflection of 0.08 in. at 5000-kg load. The upper frame should be designed for a maximum load of 5000 kg and a deflection of 0.1 in. at maximum load. The lower frame should be able to carry a maximum load of 1000 kg, and the combined deflections of the two frames should be 0.1 in. at this load. The deflection of the upper frame is 0.02 in. at a load of 1000 kg; hence, the lower frame should have a deflection of $0.1 - 0.02 = 0.08$ in. at this load, and 0.08 in. is also the required gap at the range spacer.

31. For equipment shown in figs. 11 through 17, it is assumed that deflections are measured and read directly by means of deflection dials or micrometers. It has also been indicated that the relative accuracy of the force measurements decreases with decreasing deflections, which in part is due to unavoidable small irregularities or sources of error in the dials. The forces can also be determined by correlations with strains determined by electrical strain gages cemented to the proving rings or dials. This method requires additional electrical equipment, but it allows magnification of the readings within a desired range, which in turn may eliminate the need for double-range proving rings or frames. Electrical measurement of strains is required for automatic recording and determination of rapidly changing or dynamic forces. Commercially available load cells can generally be used advantageously for these purposes.

* A table of factors for converting British units of measurement to metric units is presented on page xlii.

Design and Construction

Materials

32. Proving rings and frames for use in testing equipment should be made of materials with stable properties, a straight stress-strain curve, and little, if any, hysteresis. It is generally desirable that the materials have high elastic limits and strengths so that equipment of high capacity may be reduced to convenient size. For certified proving rings, the National Bureau of Standards recommends alloy steels with about 0.5 percent carbon, 1 percent chromium, 1.75 percent nickel, and a yield strength of about 210,000 psi (see reference 1). Several single and compound proving frames of chrome-nickel steel alloys (S. A. E. 3140 and S. A. E. 4340) have been built at WES; these steels have properties corresponding approximately to those recommended by the National Bureau of Standards for certified proving rings. The S. A. E. 52100 steel, commonly used for ball bearings, has also been used for proving rings at WES, and the chrome-vanadium S. A. E. 6150 steel is frequently used for the manufacture of springs. All these steels are heat-treated and quenched after rough machining, and they are often chrome-plated after the final grinding, in which case the calibration should be performed after the plating.

33. The special stainless steel, Almar 362, has been used in recently built proving frames at WES; this steel is heated to 1000 F and then precipitation- and age-hardened* before any machining is done. The resulting

* Some alloys may be considered as supersaturated solid solutions from which some constituents may be separated or precipitated as microscopic particles in the course of time. This causes hardening of the entire alloy, and the process may be accelerated by moderate heating followed by a slow rate of cooling (see pages 1-2 and 1-7 in reference 5).

Rockwell hardness is 36 to 37, which still allows fairly convenient machining with modern tools. Avoidance of the usual heat treatment with heating to high temperatures and subsequent quenching decreases scale formation and the danger of warping. The S. A. E. 17-4PH stainless steel has properties similar to those of Almar 362, and it is frequently used in the manufacture of strain and stress measuring equipment.

34. High-strength alloys of aluminum and magnesium, e. g., aluminum 6061-T651, have been used for proving rings and frames in cases in which light weight is desired, i. e., for hand-carried equipment or when inertial forces must be reduced in dynamic experiments. The strength of these alloys is much smaller than that of steel alloys, even after solution-hardening and aging, but this is compensated for by a corresponding reduction of the modulus of elasticity.

Design procedure

35. The usual design problem is to determine the dimensions of a proving ring or frame for a specified maximum load, P , corresponding deflection, δ , and allowable stress, σ . An explicit mathematical solution can be obtained by means of the equations shown in figs. 1 and 2 when one of the dimensions, usually the width B , is preselected, but it is often advantageous to operate with more flexible intermediate relations that facilitate changes and taking secondary requirements into consideration. For the load, P , and the moment of inertia, $I = B t^3 / 12$, the deflection can be expressed by

$$\delta = \frac{F_x P L^3}{E I} = \frac{12 \cdot F_x \cdot P}{E B} \left(\frac{L}{t}\right)^3 \quad (12)$$

where F_x is a coefficient that can be obtained from the equations shown

in figs. 1 and 2. Equation 12 yields

$$\left(\frac{L}{t}\right)^3 = \frac{6 B E}{12 F_x P} = K_\delta \quad \text{or} \quad \frac{L}{t} = (K_\delta)^{1/3} \quad (13)$$

where K_δ is a constant for given conditions. It may be noted that K_δ increases linearly with B and is inversely proportional to P . The deflection increases with the third power of L and decreases with the third power of t , but L/t is a constant for a specified load and deflection and is a very useful ratio for preliminary design.

36. The maximum moment in a proving ring or frame can be expressed by $M = N_x P L$ where N_x is a coefficient obtainable from the equations shown in figs. 1 and 2. With a section modulus,

$Z = B t^2 / 6$, the corresponding stress is then

$$\sigma = \frac{6 N_x P L}{B t^2} = \frac{6 N_x P}{B} \frac{L}{t} \frac{1}{t} \quad (14)$$

Introducing $L/t = (K_\delta)^{1/3}$ from equation 13 yields

$$\sigma = \frac{6 N_x P}{B} (K_\delta)^{1/3} \frac{1}{t} = \frac{K_\sigma}{t} \quad (15)$$

and the explicit solution $t = K_\sigma / \sigma$ for the assumed value of B .

Adjustments may be required when the obtained value of t is too small for convenient and reliable machining and final grinding of the ring or frame.

37. In equations 12-15, L is the mean diameter of a proving ring or the effective span of a proving frame, taking the influence of bosses and fillets into consideration. The influence of fillets is greater on deflections than on the maximum moment and stresses. Therefore,

use of the effective span with respect to deflections may result in a slight underestimation of the values of the moments. The width, B , is often determined by the necessary connections, but is generally between one-fifth and one-half of the effective length of span. An increase of B is equivalent to a decrease of P , but B should not be so large that uniform distribution of the load can be questioned. The maximum deflection of a single ring is usually selected between 0.05 and 0.10 in. Greater deflections may require special dials and may cause undesirable changes in the calibration factor. The allowable value of σ is the yield stress divided by a relatively small factor of safety, e. g., 1.25, since the ring or frame is pretested and strain-hardened before actual use. In some cases, it may be impractical to utilize the full allowable stress because it yields such small values of the thickness, t , that it becomes difficult to clamp a frame properly and to maintain uniform values of t during the final machining and grinding. The minimum practical value of t is probably 0.08 to 0.1 in. for an effective span greater than 5 to 6 in.

Construction and calibration

38. Referring to proving rings and frames of steel to be subjected to the usual type of heat treatment, the initial rough machining should leave sufficient material to compensate for removal of scales and for minor adjustments of warping to be made in the final machining and grinding after the heat treatment. In case the ring or frame cannot be designed with the desirable accuracy of deflections because of the influence of pyramidal bosses (fig. 9) or large fillets (figs. 14-A and 14-B), it is advisable to make the initial span slightly smaller than computed and to determine the actual required span by an initial loading

test before the final machining. This precaution may also be desirable when the heat treatment is performed by moderate heating and aging before any machining. The deep rectangular frame shown in fig. 14-C is of alloy steel formed by a special casting and heat treatment procedure that greatly reduces the required machining.

39. Surface coatings to protect against corrosion should be considered when the basic material or its alloy content cannot provide this protection, especially when the equipment may be used outdoors. Many types of integral coatings formed by chemical or electrolytic means are available and have been used. The rectangular proving frame shown in fig. 14 has a black oxide coating. The best coating is probably nickel-chromium plating. A chromium plating is antiwetting and highly corrosion resistant, and a hard chromium plating also decreases friction and wear. Plating of some heat-treated steels may cause hydrogen brittleness that should be corrected by moderate heating after plating. The thickness of nickel chromium plating varies between wide limits; it is usually less than 0.001 in. but may be increased to 0.002 in. or more for wear protection or other purposes. The thickness of a heavy plating should be considered in the final machining in order that specified final dimensions will be obtained.

40. After completion of final machining and plating but before the final calibration, it is advisable to subject the proving ring or frame to repetitive preloading (about 25 cycles) with a maximum load 10 percent greater than the design load. The repetitive preloading will cause some strain-hardening, decrease the influence of hysteresis, and eliminate a later set or stabilize the zero reading. The final adjustment of the height of range spacers and stops in double-range rings and frames should be made after the preloading, and then the final calibration should

be conducted. The initial result of a calibration test is a load-deflection diagram, but it is advisable also to compute the calibration factors for each load and plot the relation between these factors and deflections (figs. 5 and 10) rather than just determine average values by the load-deflection diagram.

41. Commonly available dial indicators for measurement of deflections seldom have a completely uniform movement, and the differences between the indicated and actual deflections may at times be as great as plus or minus two or three dial divisions. Such deviations may be decreased to about one dial division for the best type of dials. Therefore, the final calibration of proving rings or frames, using dial indicators for deflection measurement, should be performed with the same dial and same zero setting that will be used during subsequent tests. It should be noted when and where the readings of the indicator dial deviate from a smooth and simplified calibration curve. The calibration should be repeated if the original dial is replaced with another dial.

Literature Cited

1. Wilson, B. L., Tate, D. R., and Borkowski, G. (1946). "Proving Rings for Calibrating Testing Machines." Circular C454, 21 pages, National Bureau of Standards, Washington, D.C.
2. Hvorslev, M. J. and Kaufman, R. I. (1952). "Torsion Shear Apparatus and Testing Procedures." Bulletin No. 38, 76 pages, Waterways Experiment Station, Corps of Engineers, U. S. Army.
3. Timoshenko, S. (1941). Strength of Materials - Part I. Second Edition, 510 pages. D. van Nostrand Co., Inc., New York.
4. Timoshenko, S. and Goodier, J. N. (1951). Theory of Elasticity. Second Edition, 506 pages. McGraw-Hill Book Co., Inc., New York.
5. Mantell, C. L., Editor (1958). Engineering Materials Handbook. McGraw-Hill Book Co., Inc., New York.

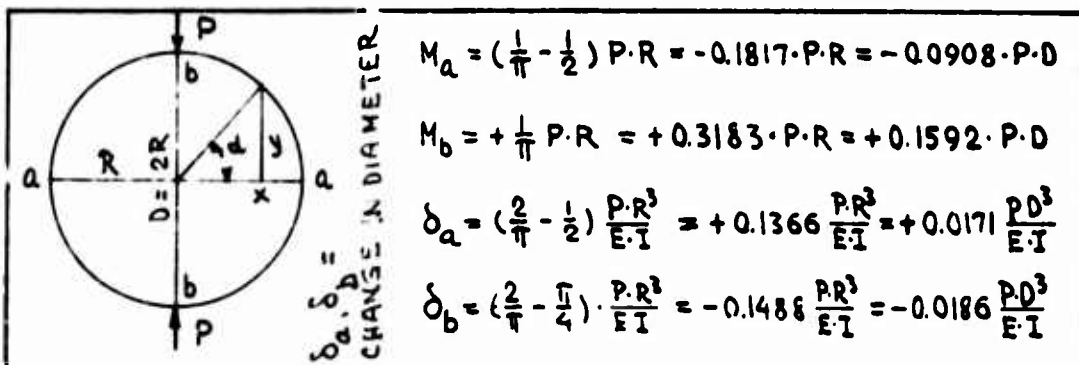

a. Thin full circular ring

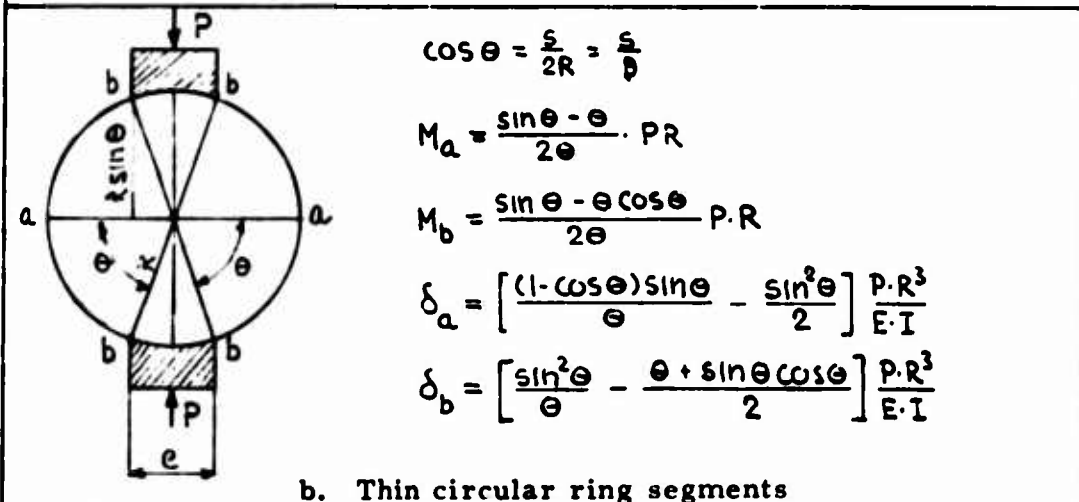

b. Thin circular ring segments

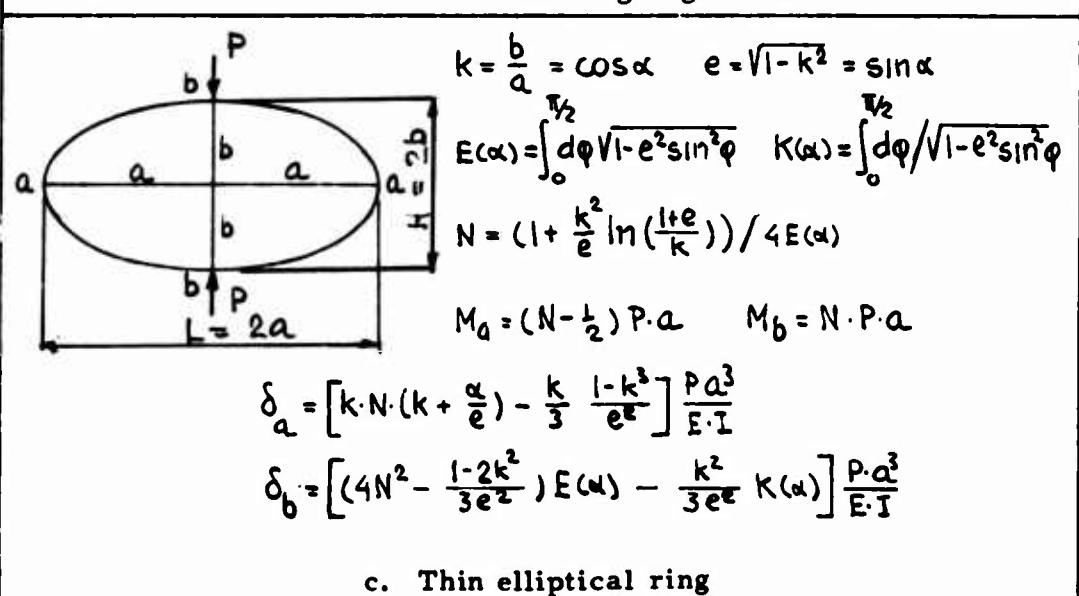

c. Thin elliptical ring

Fig. 1. Moments and deflections of thin rings

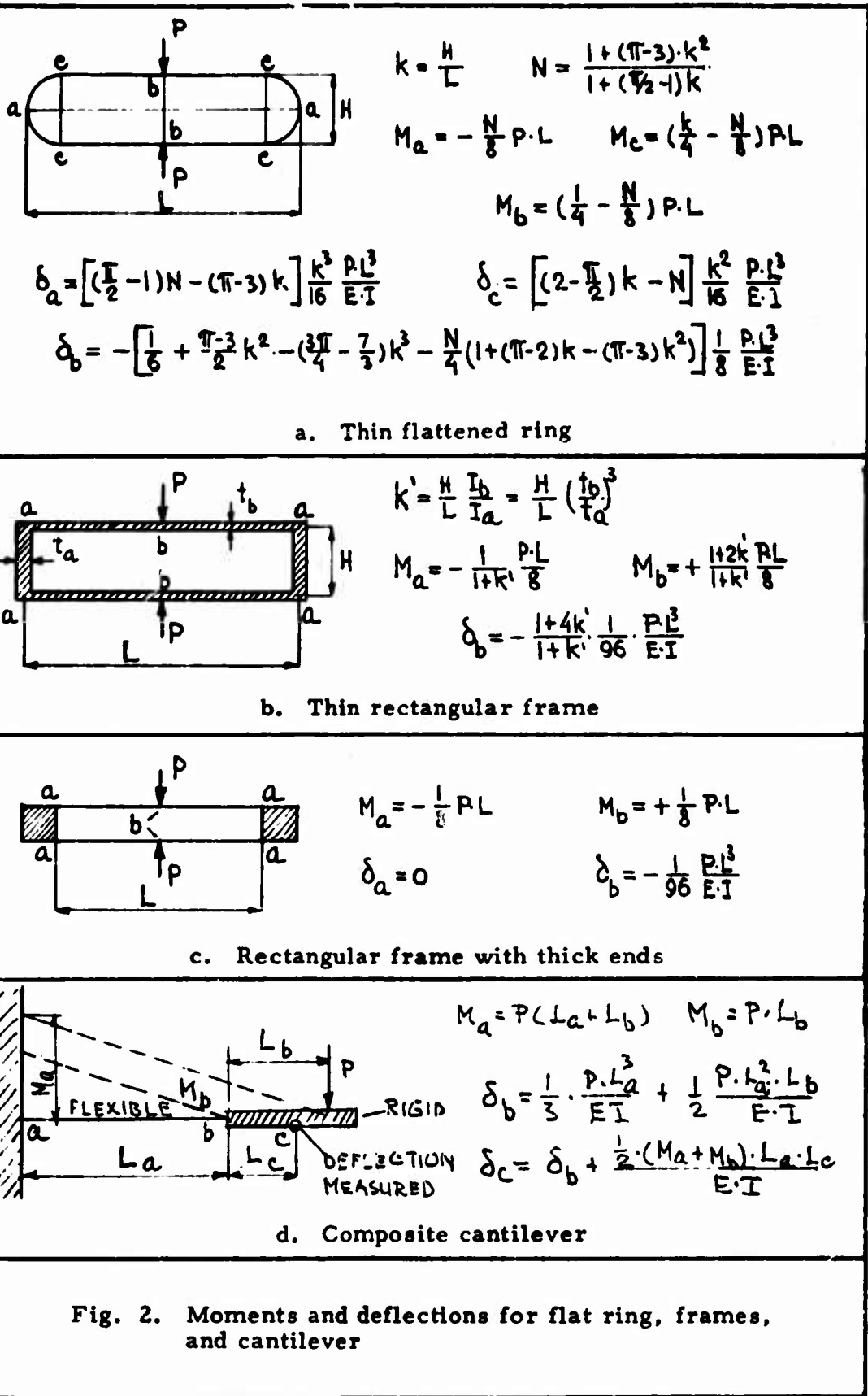

Fig. 2. Moments and deflections for flat ring, frames, and cantilever

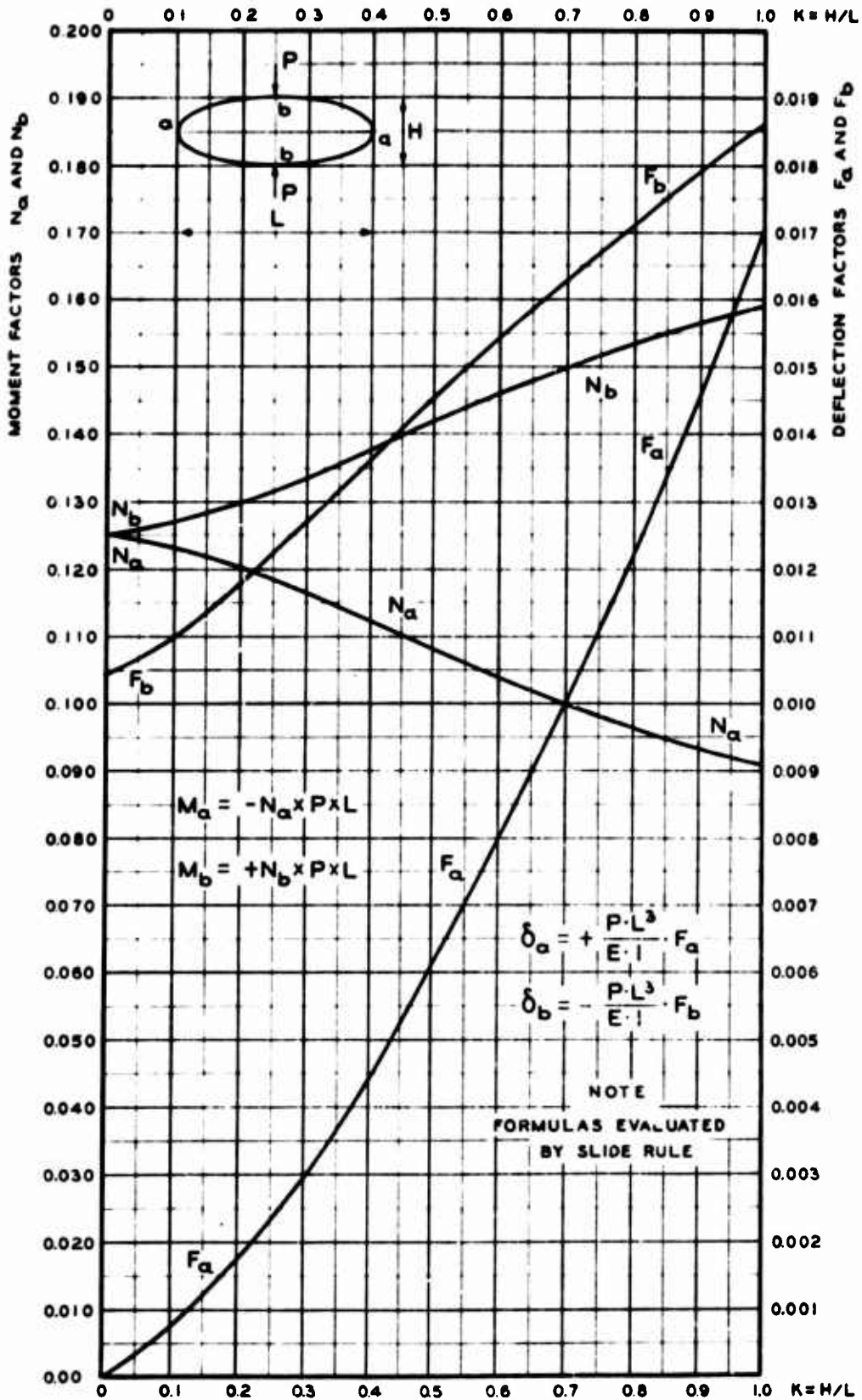

Fig. 3. Moment and deflection factors for elliptical rings

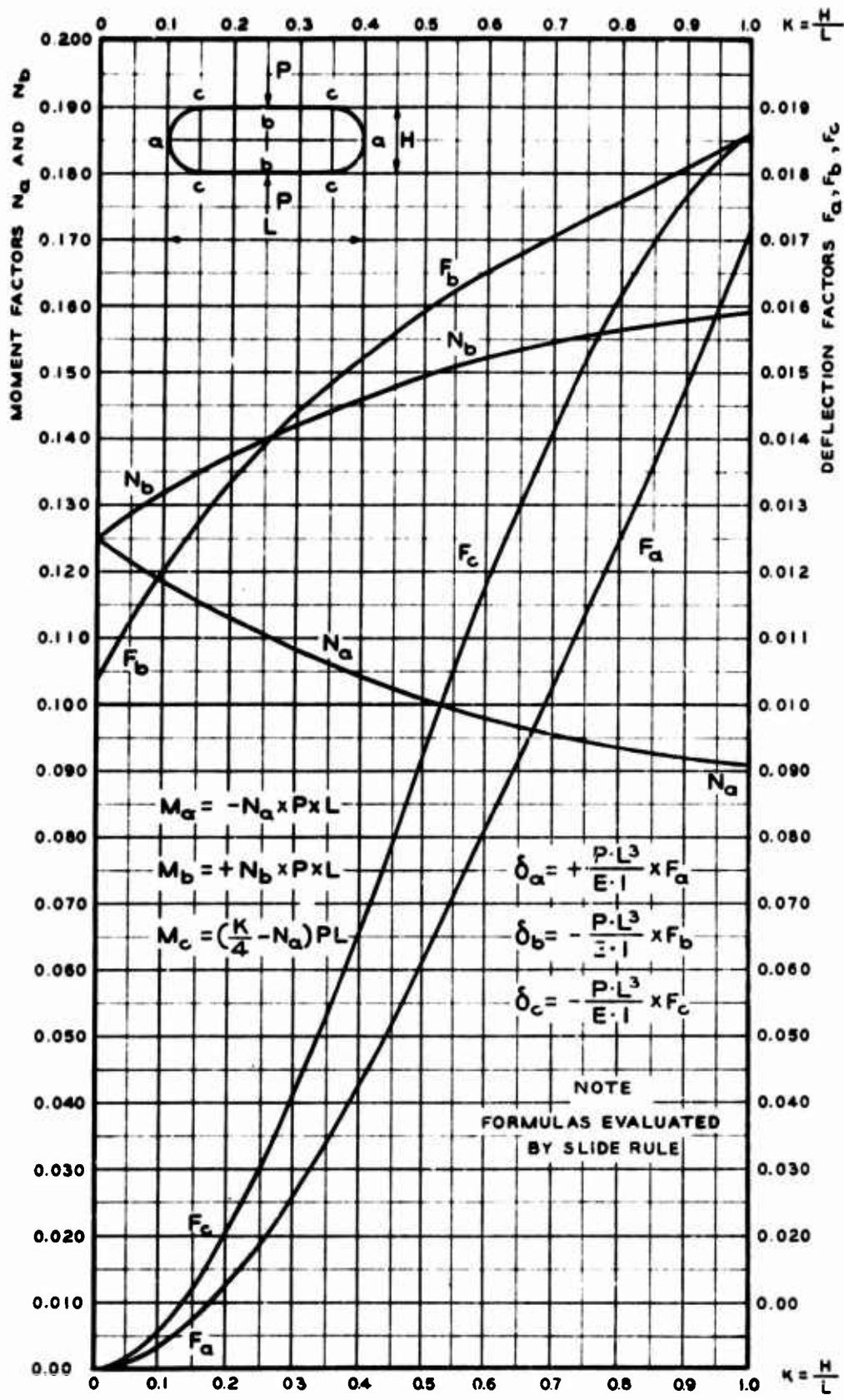

Fig. 4. Moment and deflection factors for flat rings

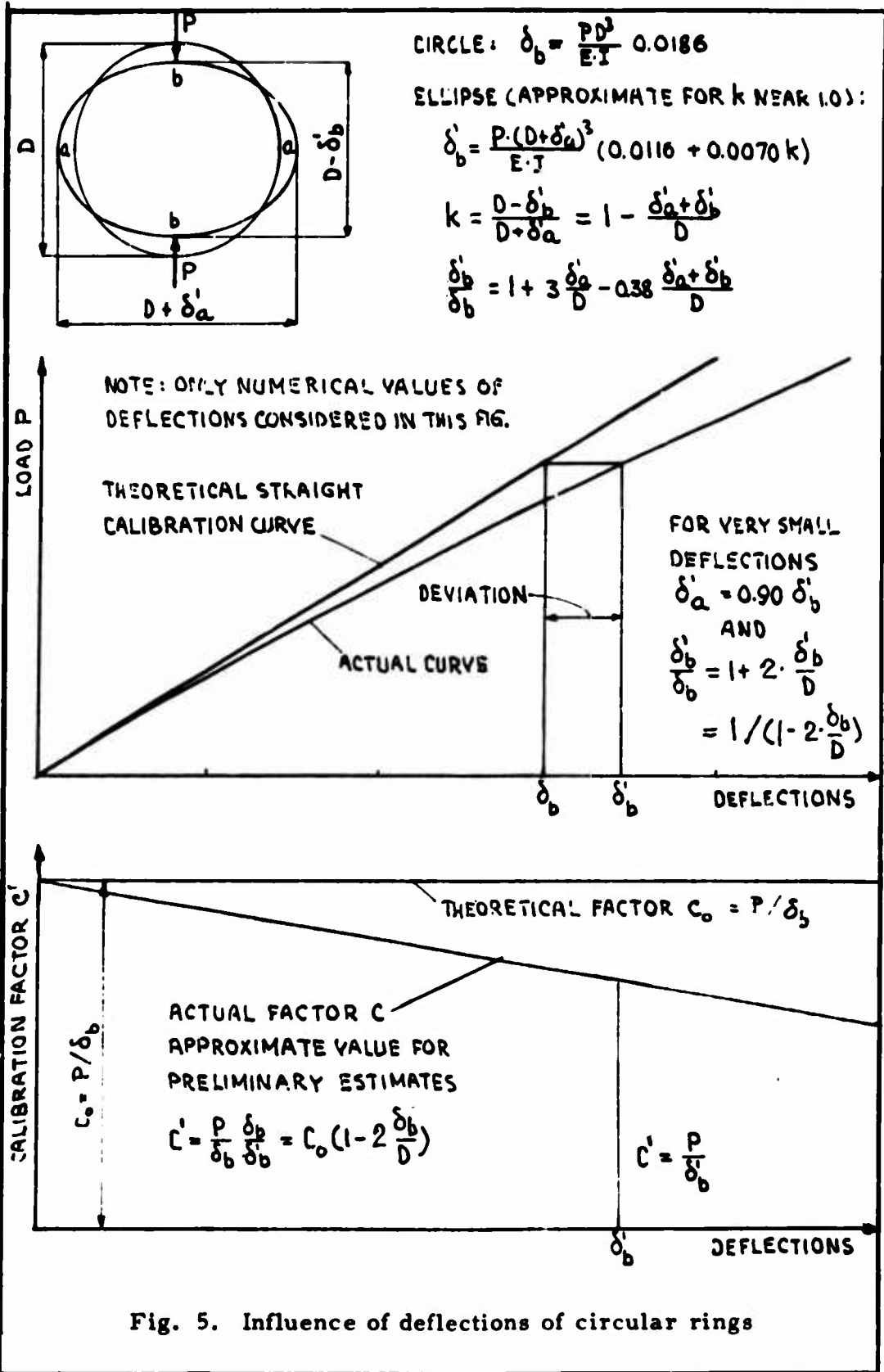

Fig. 5. Influence of deflections of circular rings

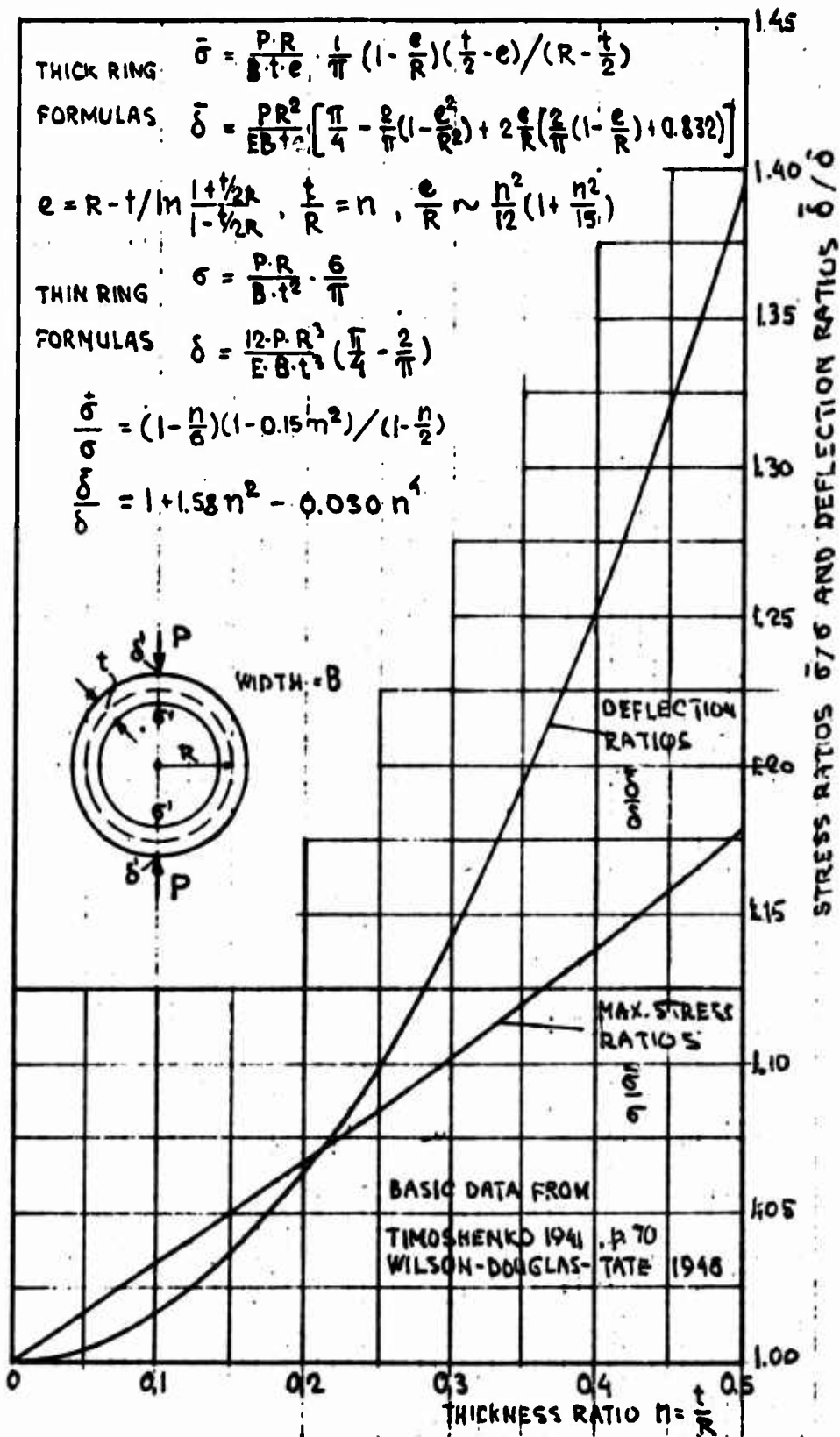
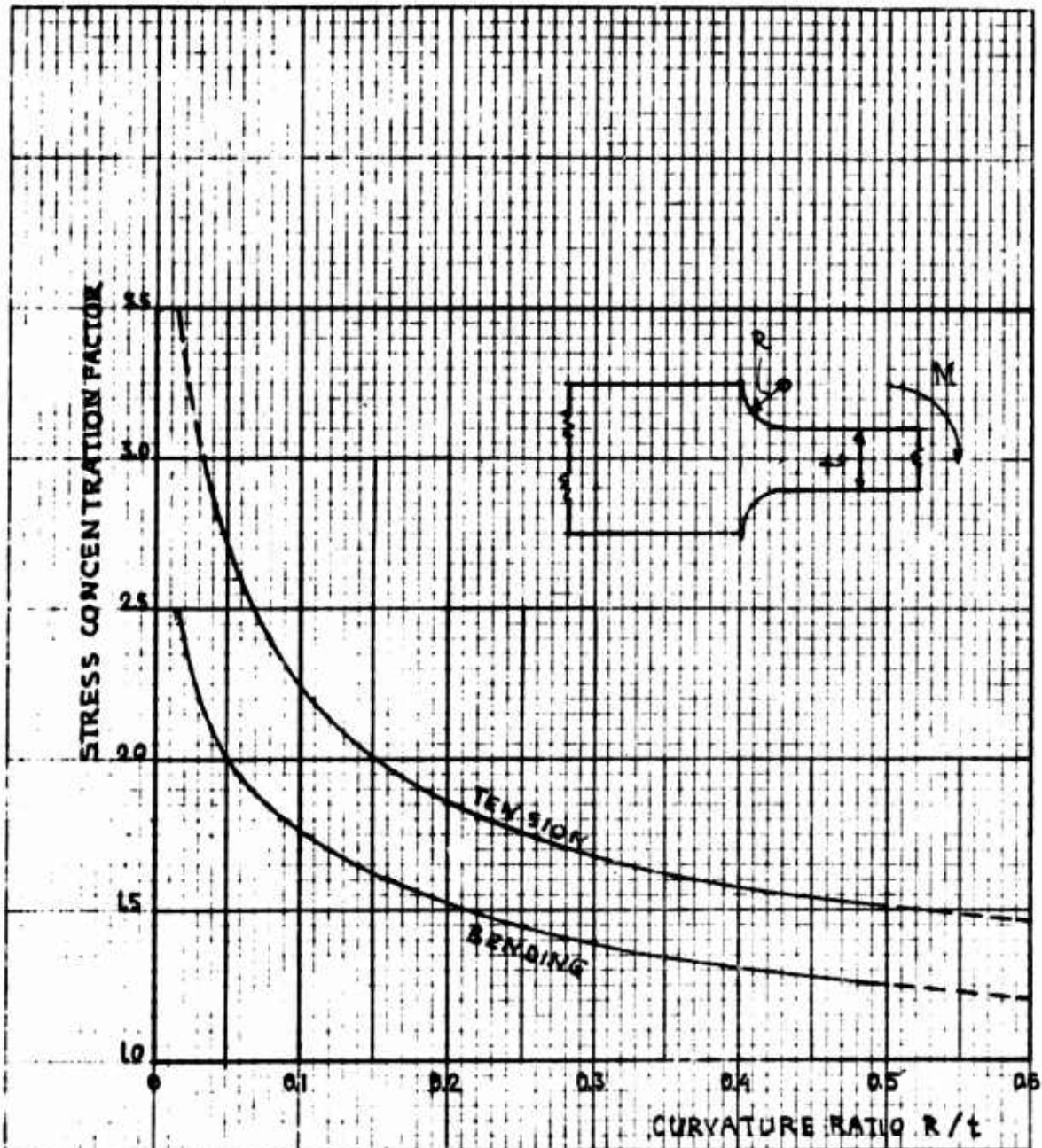
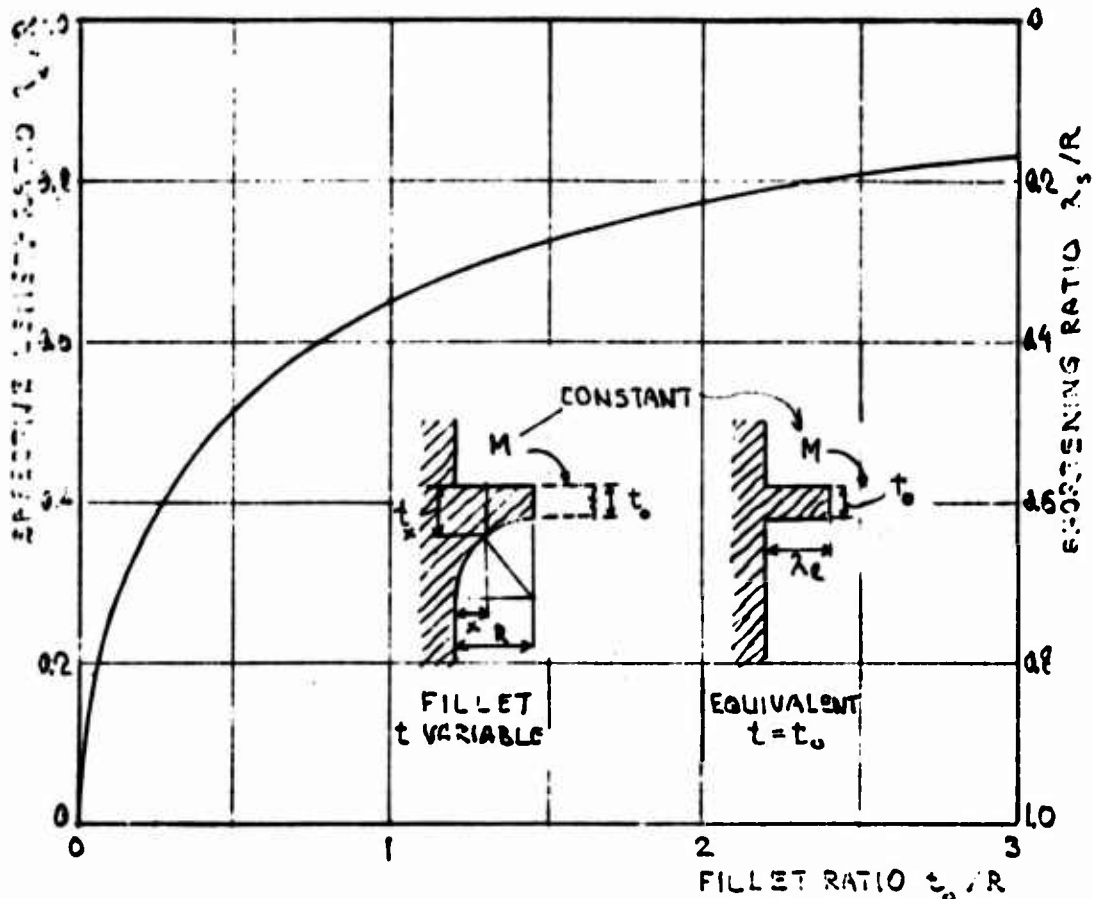

Fig. 6. Errors made by using thin-ring formulas



Note: Data were taken from reference 4.

Fig. 7. Stress concentration factors and fillets



FOR EQUAL ANGULAR DEFLECTIONS OF FILLET AND EQUIVALENT PLATE

$$\int_0^R \frac{M \cdot dx}{E \cdot I_x} = \int_0^{\lambda_e} \frac{M \cdot dx}{E \cdot I_0} = \frac{M \cdot \lambda_e}{E \cdot I_0}$$

$$\begin{aligned} x &= R(1 - \cos \varphi) \\ t_x &= t_0 + R(1 - \sin \varphi) \\ m &= 1 + t_0/R \end{aligned}$$

$$\lambda_e = \int_0^R \frac{I_0}{I_x} dx = \int_0^R \frac{t_0^3}{t_x^3} dx = \int_0^{\pi/2} \frac{t_0^3 \cdot R \cdot \sin \varphi \cdot d\varphi}{(t_0 + R(1 - \sin \varphi))^3} = \frac{t_0^3 R}{R^3} \int_0^{\pi/2} \frac{\sin \varphi \cdot d\varphi}{(m - \sin \varphi)^3}$$

$$\frac{\lambda_e}{R} = \frac{t_0^3}{R^2} \cdot \frac{1}{2(m^2-1)^2} \left[\frac{2m^2+1}{m} + \frac{6m}{\sqrt{m^2-1}} \arctan \sqrt{\frac{m+1}{m-1}} \right]$$

$$\lambda_s = R - \lambda_e = \text{SHORTENING EFFECT OF FILLET}$$

THIS SIMPLIFIED SOLUTION YIELDS ONLY APPROXIMATE RESULTS AND MAY IN SOME CASES OVERESTIMATE THE SHORTENING EFFECT, λ_s

Fig. 8. Influence of fillets on deflections

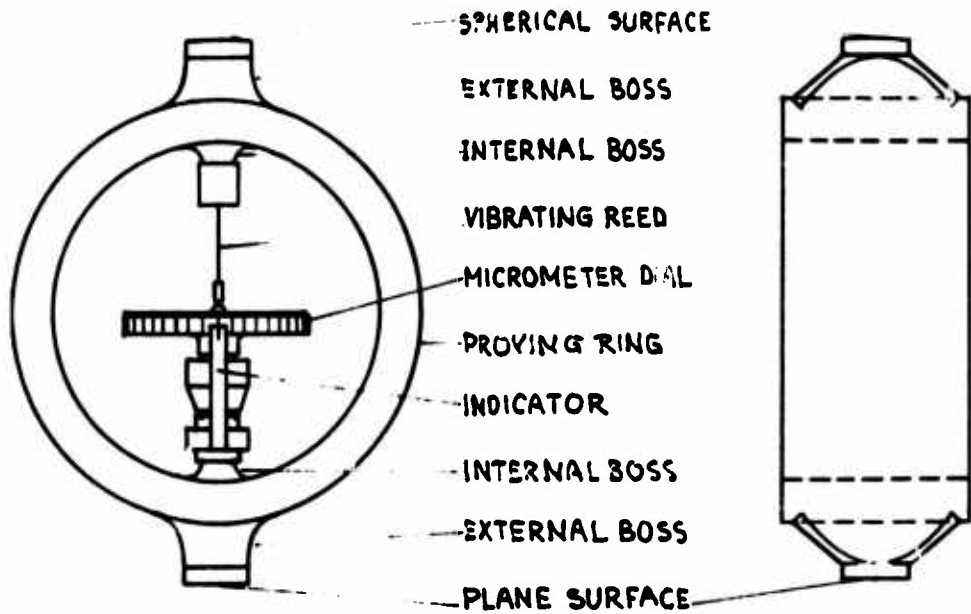

Fig. 9. Proving ring with integral bosses

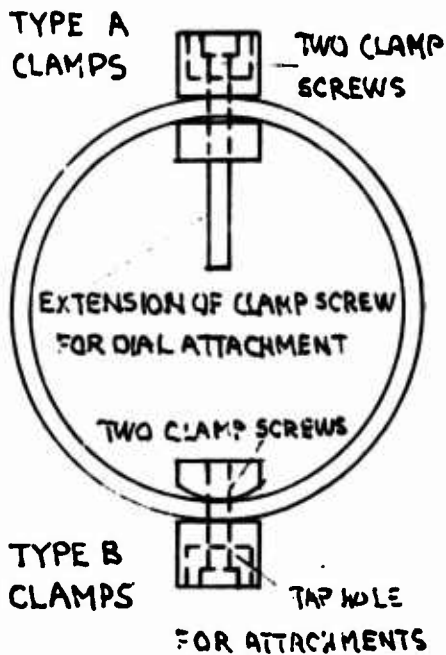
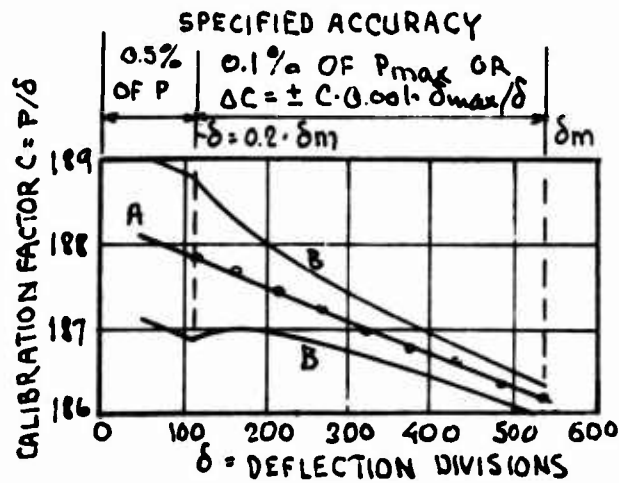

Fig. 11. Rings with clamps



A = ACTUAL CALIBRATION LINE
 B = SPECIFIED DEVIATION LIMITS
 FROM WILSON-TATE-BORKOWSKI 1947

Fig. 10. Calibration factors and limits

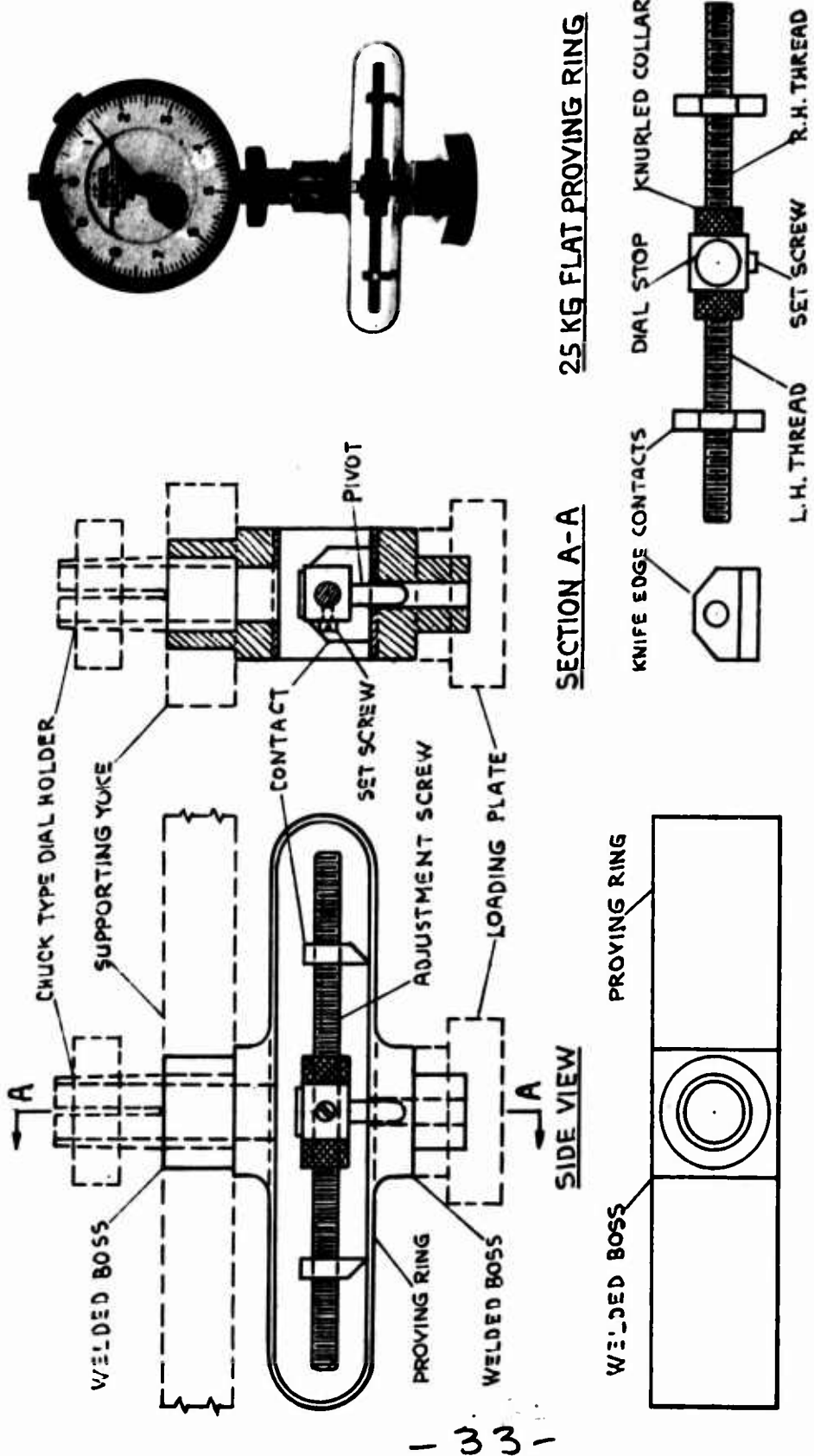
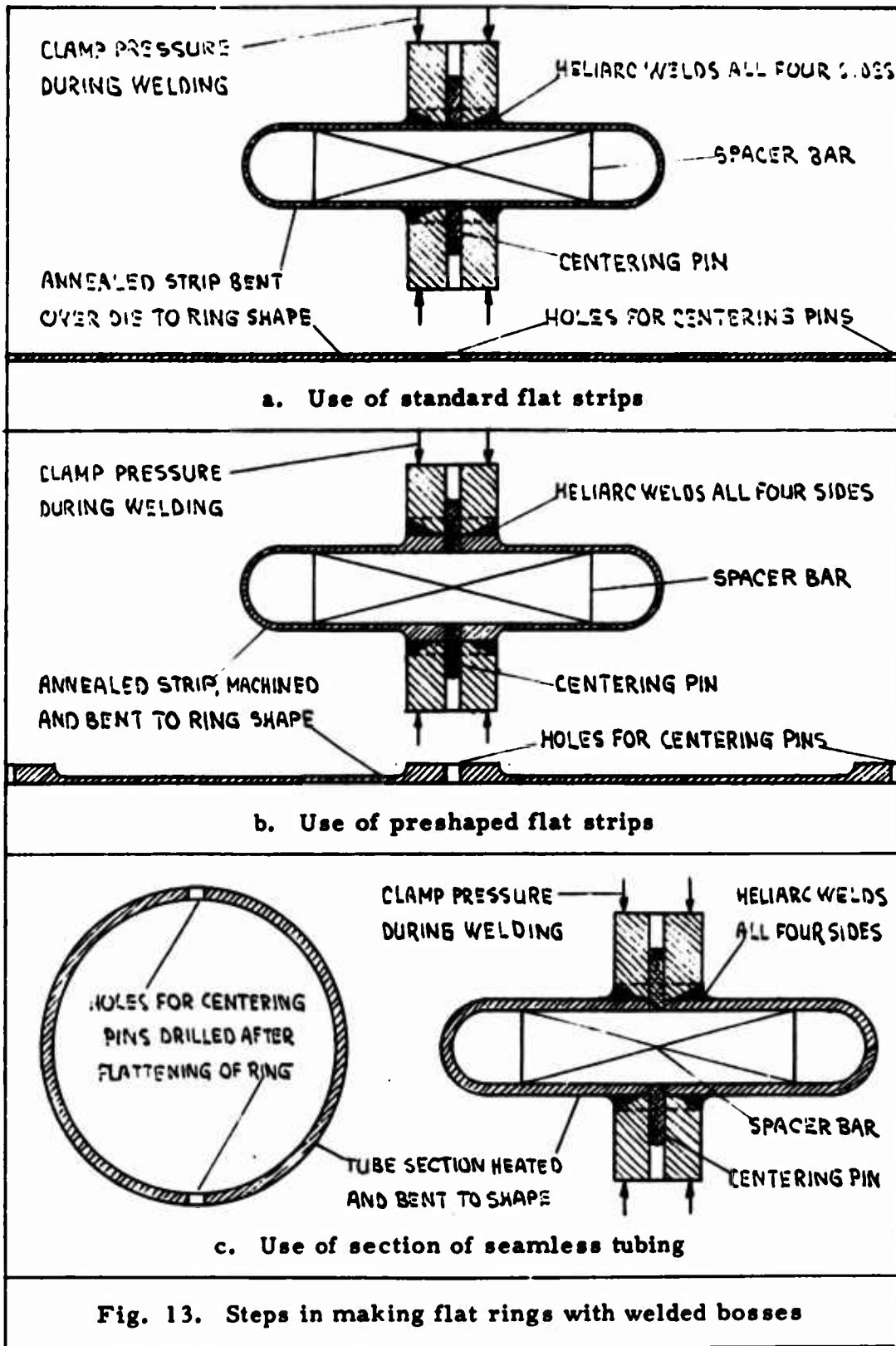
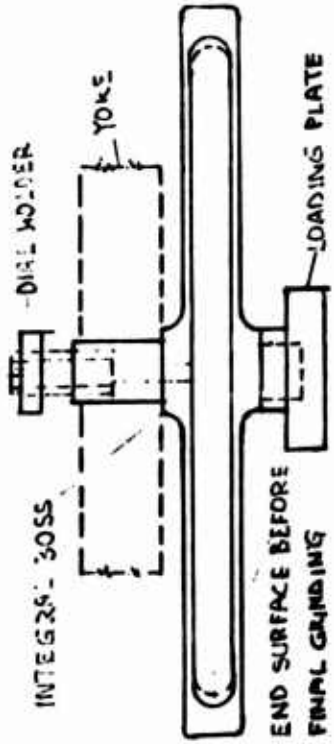
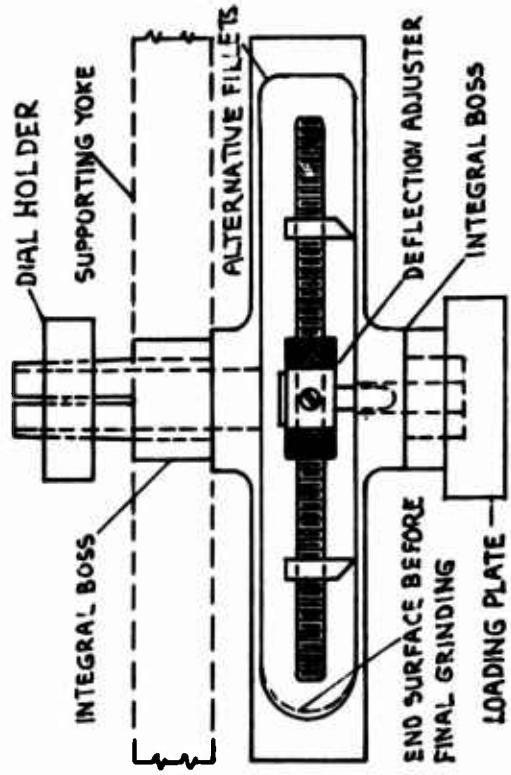

Fig. 12. Flat proving rings with deflection adjustment





a. Flat proving frame



b. Frame with deflection adjuster

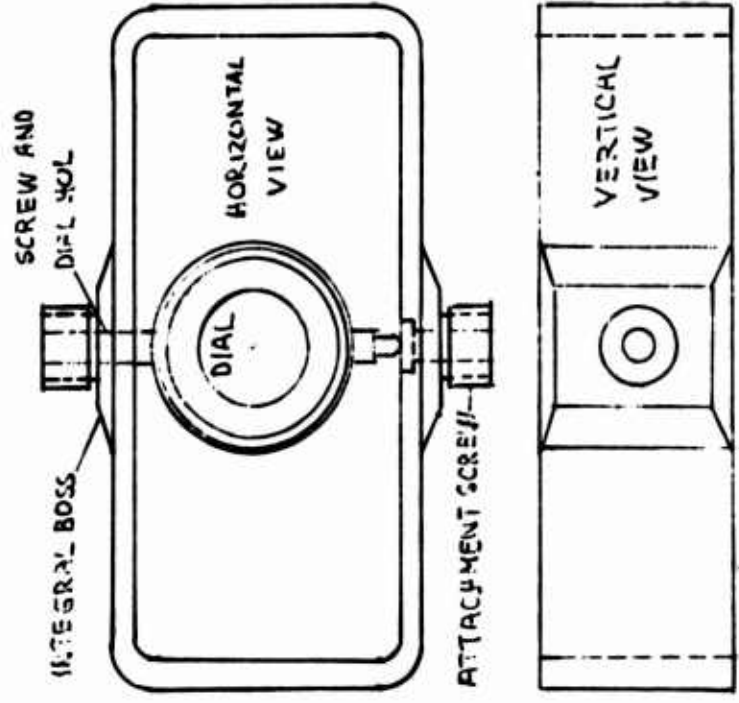

c. Deep proving frame

Design by Norwegian Geotechnical Institute

Fig. 14. Rectangular proving frames

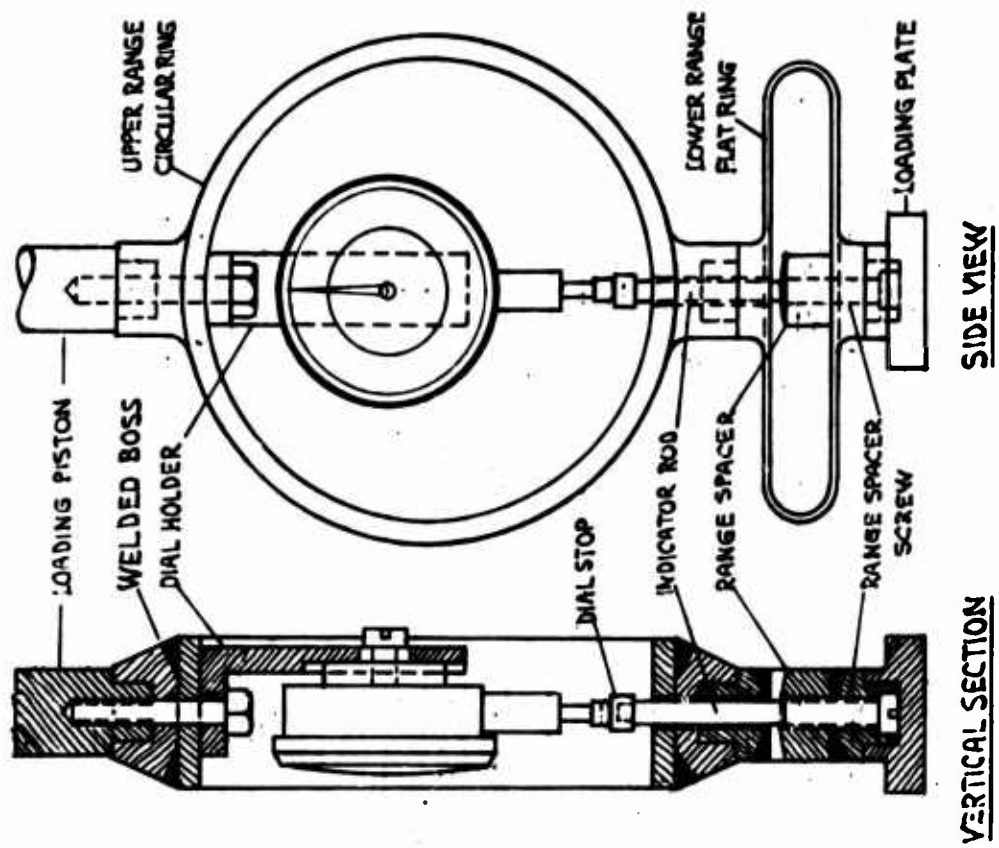

Fig. 16. Combined circular and flat proving rings

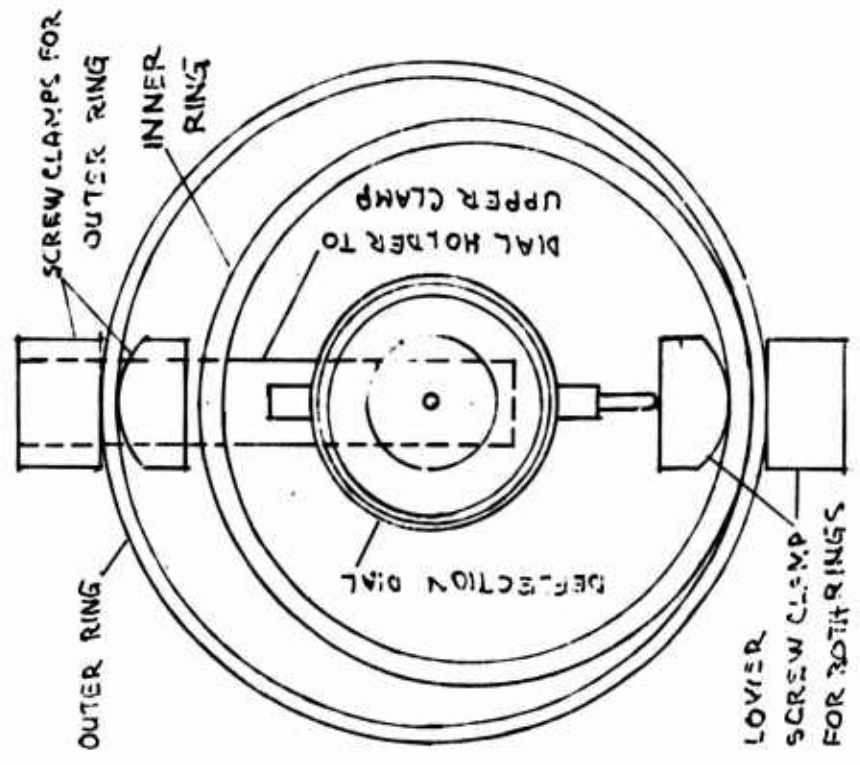

Fig. 15. Double-range proving rings

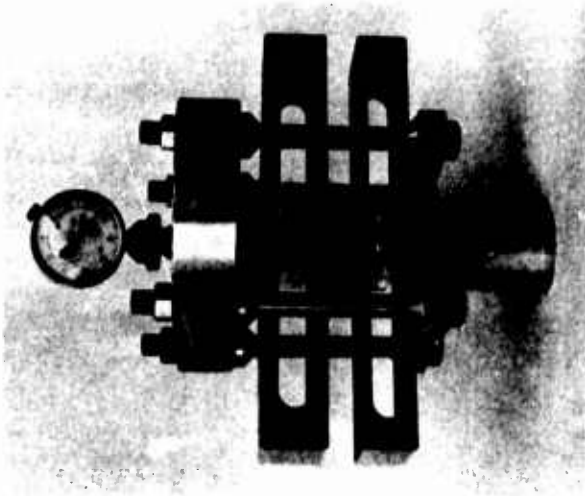
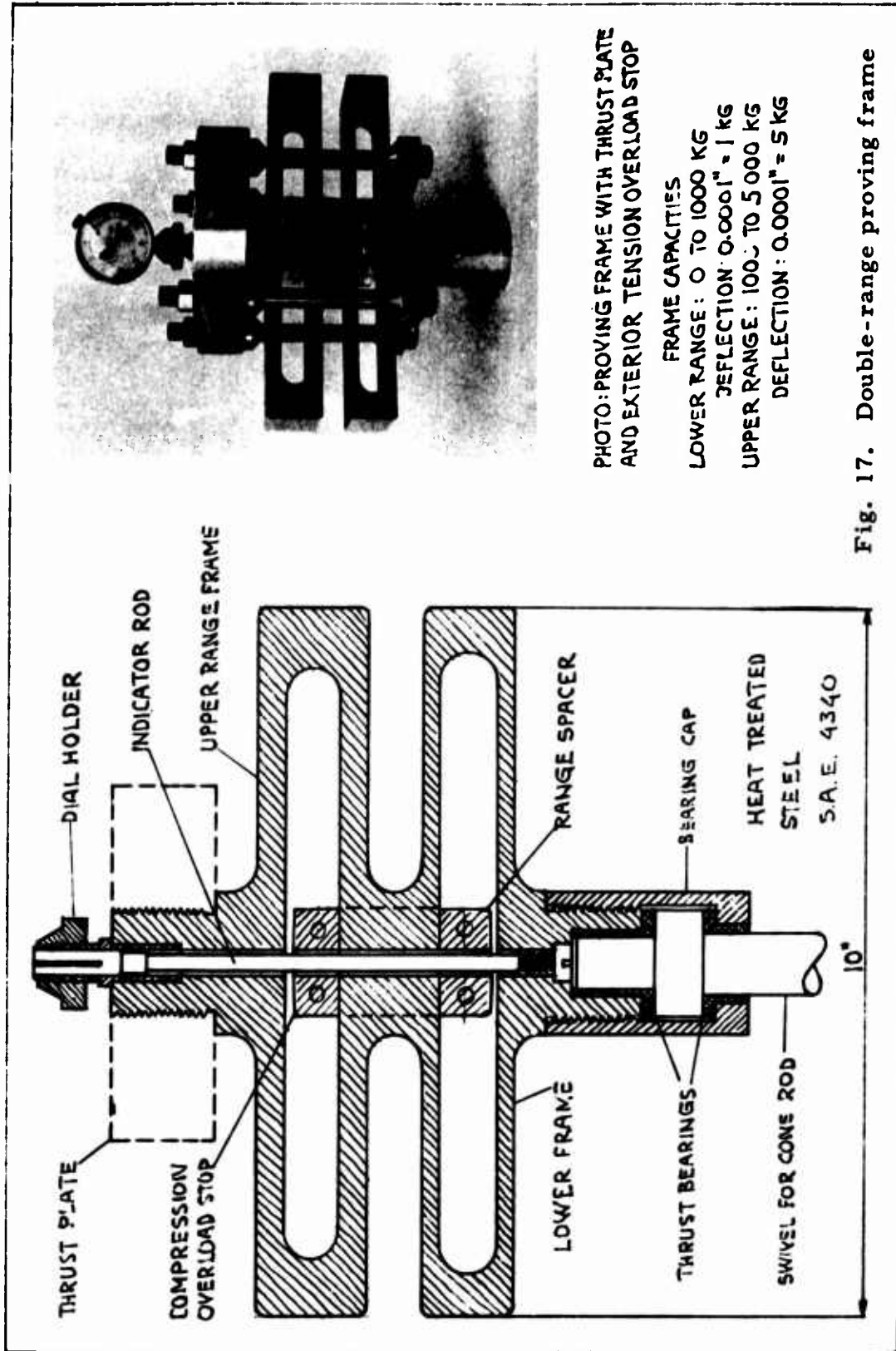

PHOTO: PROVING FRAME WITH THRUST PLATE AND EXTERIOR TENSION OVERLOAD STOP

FRAME CAPACITIES
 LOWER RANGE: 0 TO 1000 KG
 DEFLECTION: 0.0001" = 1 KG
 UPPER RANGE: 1000 TO 5000 KG
 DEFLECTION: 0.0001" = 5 KG

Fig. 17. Double-range proving frame