

AD-756 708

COMPUTER NETWORK RESEARCH

Leonard Kleinrock

California University

Prepared for:

Advanced Research Projects Agency

31 December 1972

DISTRIBUTED BY:

NTIS

**National Technical Information Service
U. S. DEPARTMENT OF COMMERCE
5285 Port Royal Road, Springfield Va. 22151**

AD756708

COMPUTER NETWORK RESEARCH
ADVANCED RESEARCH PROJECTS AGENCY
SEMIANNUAL TECHNICAL REPORT

December 31, 1972

Reproduced by
**NATIONAL TECHNICAL
INFORMATION SERVICE**
U.S. Department of Commerce
Springfield, VA 22151

Principal Investigator: Leonard Kleinrock

**Co-Principal Investigators: Gerald Estrin
Michel Melkanoff
Richard R. Muntz**

DISTRIBUTION STATEMENT A
Approved for public release;
Distribution Unlimited

**Computer Science Department
School of Engineering and Applied Science
University of California, Los Angeles**



82

Sponsored by
ADVANCED RESEARCH PROJECTS AGENCY

COMPUTER NETWORK RESEARCH
SEMIANNUAL TECHNICAL REPORT

December 31, 1972

ARPA Contract DAHC-15-69-C-0285

ARPA Order No. 1380

*Details of illustrations in
this document may be better
studied on microfiche.*

Principal Investigator: Leonard Kleinrock
Co-Principal Investigators: Gerald Estrin
Michel Melkanoff
Richard R. Muntz

Computer Science Department
School of Engineering and Applied Science
University of California, Los Angeles

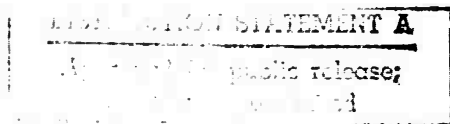

The views and conclusions contained in this document are those of the authors and should not be interpreted as necessarily representing the official policies, either expressed or implied, of the Advanced Research Projects Agency or the United States Government.

I

UNCLASSIFIED

Security Classification

DOCUMENT CONTROL DATA - R & D

Security classification of title, body of abstract and indexing annotation must be entered when the overall report is classified

ORIGINATING AGENCY (Corporate author)
Computer Science Department
School of Engineering and Applied Science 90024
405 Hilgard, University of California, Los Angeles

2a. REPORT SECURITY CLASSIFICATION

Unclassified

2b. GROUP

1. REPORT TITLE

Computer Network Research

3. DESCRIPTIVE NOTES (Type of report and inclusive dates)

4. AUTHOR(S) (First name, middle initial, last name)

Leonard Kleinrock

5. REPORT DATE

December 21, 1972

7. TOTAL NO. OF PAGES

70 7.2

7b. NO. OF REFS

95

6a. CONTRACT OR GRANT NO

DAHC-15-69-C-0285

9a. ORIGINATOR'S REPORT NUMBER(S)

9b. OTHER REPORT NO(S) (Any other numbers that may be assigned this report)

6b. PROJECT NO

1380

8. DISTRIBUTION STATEMENT

Distribution of this document is unlimited.

10. SUPPLEMENTARY NOTES

12. SPONSORING MILITARY ACTIVITY

14. ABSTRACT

ARPA Semiannual Technical Report July 1, 1972 through December 21, 1972.

COMPUTER NETWORK RESEARCH

Advanced Research Projects Agency
Semiannual Technical Report

December 31, 1972

1. INTRODUCTION

This Semiannual Technical Report covers the period July 1, 1972 through December 31, 1972. Our activities have ranged from network measurement studies to theoretical analysis of computer systems operation. Included in this research has been an extensive study by Mario Gerla on design methods for store-and-forward computer-communication networks; this study has led to his successful completion of the Ph.D. degree in Computer Science under the direction of Professor Leonard Kleinrock. The study considers many important problems in computer-communication network design. For example, a method for obtaining the optimal assignment of flow within a network in which the capacity assignment has already been made is carefully studied; a rather efficient algorithm for locating this optimal flow has been found. The more difficult question of channel capacity assignment in a network where the flows have already been assigned is also considered and those cases leading to optimal solutions are classified; in the remaining cases, heuristic design procedures are described. The combined flow and channel capacity assignment problem is discussed and an iterative algorithm is developed which leads to a class of suboptimal solutions. In this iterative method, one finds that certain channels are assigned zero capacity and, as a consequence, the topology of the network varies as the algorithm proceeds. This has led to considerable insight into topological design procedures, and it is this aspect of Gerla's thesis which we present in detail in Section 3 of this report. That section is excerpted from Gerla's dissertation and, as a result, all of the numbers (section numbers, equation numbers, figure numbers, etc.) have been left unaltered as they appeared in the dissertation (Ref. [9]). The order of presentation is to give the abstract of the thesis, a description of the combined capacities and flow assignment problem with all the required notations, and then finally, a detailed chapter on our experience with the topological design using the ARPA Network as an example. The complete dissertation is to appear as a UCLA Engineering Report in the "Computer Systems Modeling and Analysis" series and will be available shortly.

Our other significant accomplishments will not be described in this report, having devoted it to the topological design mentioned above and detailed in Section 3. Below, in Section 2, we give a list of publications which have appeared during this period.

2. LIST OF PUBLICATIONS (July 1, 1972 - December 31, 1972)

1. Baskett, F., and R. R. Muntz, "Queueing Network Models with Different Classes of Customers," Proc. COMPCON 72 Sixth Annual IEEE Computer Society International Conference, San Francisco, Calif., Sept. 12-14, 1972, pp. 205-209.
2. Cantor, D. G., and M. Gerla, "The Optimal Routing of Messages in a Computer Network via Mathematical Programming," Proc. COMPCON 72 Sixth Annual IEEE Computer Society International Conference, San Francisco, Calif., Sept. 12-14, 1972, pp. 167-170.
3. Cerf, V. G., and G. Estrin, "Measurement of Recursive Programs," Proc. International Federation for Information Processing Congress 71, Aug. 23-28, Ljubljana, Yugoslavia, North-Holland Publishing Co., Amsterdam, 1972, TA-2, pp. 314-319.
4. Cerf, V. G., E. F. Harslem, J. F. Heafner, R. M. Metcalfe, and J. E. White, "An Experimental Service for Adaptable Data Reconfiguration," IEEE Transactions on Communications, June 1972, COM-20:557-564.
5. Cerf, V. G., and W. Naylor, "Selected ARPA Network Measurement Experiments," Proc. COMPCON 72 Sixth Annual Computer Society International Conference, San Francisco, Calif., Sept. 12-14, 1972, pp. 201-204.
6. Cerf, V. G., and W. E. Naylor, "Storage Considerations in Store-and-Forward Message Switching," 1972 Wescon Technical Papers, "Computer Networks," Sept. 19-22, 1972.
7. Chu, W. W., "Some Recent Advances in Computer Communications," Proc. First USA-JAPAN Computer Conference, 1972, Tokyo, Japan, Oct. 3-5, 1972, pp. 514-519.
8. Chu, W. W., and A. G. Konheim, "On the Analysis and Modeling of a Class of Computer Communication Systems," IEEE Transactions on Communications, June 1972, COM-20:645-660.
9. Gerla, M., "The Design of Store-and-Forward (S/F) Networks for Computer Communications," Ph.D. Dissertation, School of Engineering and Applied Science, Computer Science Department, University of California, Los Angeles, December 1972.
10. Kleinrock, L., Communication Nets: Stochastic Message Flow and Delay, McGraw-Hill, New York, 1964 (out of print). Reprinted by Dover Publications, New York, 1972.
11. Kleinrock, L., "A Selected Menu of Analytical Results for Time-Shared Computer Systems." In Systemprogrammierung, R. Oldenbourg Verlag, Munich, Germany, 1972, pp. 45-73.

12. Kleinrock, L., R. Muntz, and J. Hsu, "Tight Bounds on Average Response Time for Processor-Sharing Models of Time-Shared Computer Systems," Proc. International Federation for Information Processing Congress 71, Aug. 23-28, Ljubljana, Yugoslavia, North-Holland Publishing Co., Amsterdam, 1972, TA-2, pp. 124-133.
13. Kleinrock, L., H. Frank, and R. E. Kahn, "Computer-Communication Network Design--Experience with Theory and Practice," AFIPS Conference Proc., SJCC, April 16-18, 1972, Atlantic City, N.J., pp. 255-270. Also Networks, 2:135-166, 1972.
14. Kleinrock, L., and R. Muntz, "Processor-Sharing Queueing Models of Mixed Scheduling Disciplines for Time-Shared Systems," J. Association for Computing Machinery, July 1972, 19:464-482.
15. Kleinrock, L., and S. Lam, "Analytical Results for the Arpanet Satellite System Model Including the Effects of the Retransmission Delay Distribution," Arpanet Satellite System ASS Note #12, Aug. 22, 1972.
16. Kleinrock, L., "Performance Models and Measurements of the ARPA Computer Network," ONLINE 72 Conference Proc. on Online Interactive Computing, Sept. 2-7, 1972, Brunel University, Uxbridge, Middlesex, England, pp. 61-85.
17. Kleinrock, L., and S. S. Lam, "Approximations in the Infinite Population Model of the Arpanet Satellite System," Arpanet Satellite System ASS Note #17, Oct. 3, 1972.
18. Kleinrock, L., "Computer Network Design Principles Derived from Experience and Measurements on the ARPA Network," Summary in Proc. International Telemetering Conference, Oct. 11, 1972, Los Angeles, Calif., p. 440.
19. Kleinrock, L., and S. S. Lam, "Analytic Results with the Addition of One Large User," Arpanet Satellite System ASS Note #27, Oct. 30, 1972.
20. Kleinrock, L., and S. S. Lam, "Correction for ASS Note #12," Arpanet Satellite System ASS Note #25, Nov. 20, 1972.

3. THE DESIGN OF STORE-AND-FORWARD (S/F) NETWORKS FOR COMPUTER COMMUNICATIONS, Ph.D. Dissertation by Mario Gerla

ABSTRACT

The emphasis of this research is on the development of mathematical programming tools for the design of S/F communication networks.

An analytical model for the system is first presented and discussed. The design variables (routing of messages, channel capacities, topology, etc.) are then defined and proper design criteria (delay, cost, thruput, etc.) are established and expressed in terms of the variables. Next, various design problems are defined and investigated; the most significant of them are the following:

1. Find the minimum cost channel capacity assignment, given the routing of the messages and the maximum admissible delay T .
2. Find the routing which minimizes the delay, given the channel capacities (and therefore the cost).
3. Find the routing and capacities assignment which minimizes the cost, given the maximum admissible delay T .
4. Find the topology, routing and capacities assignment which minimizes the cost, given the maximum admissible delay T .

For these problems, either the exact solution is presented, or a good heuristic approach is proposed.

Several examples and applications are discussed; most of them refer to the ARPA computer network, one "node" of which is operated by the Computer Science Department of UCLA.

Finally, the validity of the results and their sensitivity to changes in the model is discussed.

THE TOPOLOGICAL DESIGN OF S/F NETWORKS

Below we provide a self-contained treatment of the topological design problem. In particular, the sections from Chapter 5 show that the topological problem can be considered as a concave minimum cost flow problem, and outline an algorithm for the determination of local minima. The sections from Chapter 6 discuss various applications to the ARPA Computer Network.

CHAPTER 5

CAPACITIES AND FLOW ASSIGNMENT (CFA)

5.1 Introduction

In Chapters 3 and 4 we presented methods for the exact solution of the capacities assignment (CA) and of the flow assignment (FA) problems separately. In Chapters 5 and 6 we develop methods for the suboptimal solution of the simultaneous capacities and flow assignment (CFA) problem and of the topological problem. In fact, there exist no efficient methods for the exact solution, mainly because of the difficulties presented by a nonconvex objective function (several local minima), by discrete capacity levels and, in the case of the topological design, by the combinatorial nature of the topological configuration considered as a variable.

In the present chapter we discuss the problem of the simultaneous assignment of capacities and flows (CFA problem).

5.2 Problem FormulationProblem (5.1)

given: topology

requirement matrix R

cost-cap functions $d_i(C_i)$, $\forall i = 1, \dots, NA$

$$\underset{\text{over } \underline{C}, \underline{f}}{\text{minimize}} \quad D(\underline{C}) = \sum_{i=1}^{NA} d_i(C_i)$$

constraints:

(a) \tilde{f} is a multicommodity (m.c.) flow satisfying the requirement matrix R

(b) $\tilde{f} \leq \tilde{C}$

$$(c) T(\tilde{f}, \tilde{C}) = \frac{1}{\gamma} \sum_{i=1}^{NA} f_i \left[\frac{1}{C_i - f_i} \right]^* \leq T_{\max}$$

Where

NN : # of nodes

NA : # of arcs

$D(\tilde{C})$: total network cost, as a function of channel capacities

$\tilde{C} \triangleq (C_1, C_2, \dots, C_{NA})$: vector of channel capacities

C_i : channel capacity in channel i [bits/sec]

$\tilde{f} \triangleq (f_1, f_2, \dots, f_{NA})$: vector of channel rates

$R \triangleq \{r_{ij}\}$: requirement matrix

r_{ij} : average traffic requirement from node i to node j ; [bits/sec]

$1/\mu \triangleq$ average message length [bits/message]

$\gamma \triangleq \mu \sum_{i,j} r_{ij}$: total thruput [message/sec]

T : total average delay [sec/message]

In a recent paper [FRAT 73], the delay T , instead of the cost D , was chosen as objective function of an analogous problem (and therefore a cost constraint, instead of a delay constraint, was considered). Here we selected the cost D for the reason, already mentioned in Section 4.9, that the delay is a too sensitive performance criterion.

* See [KLEI 64].

Problem (5.1) is much more complex than the routing problem with fixed capacities. The objective $D(\underline{C})$ is in general nonconvex, and the set defined by constraint $T(\underline{f}, \underline{C}) \leq T_{\max}$ is also nonconvex, as the function $T(\underline{f}, \underline{C})$ is nonconvex: * therefore the problem presents several local minima. Notice that the capacity constraint (b) is implied by the delay constraint (c) and can therefore be disregarded.

5.4 Linear Cost-Cap Functions

It was shown in Section 3.3 that, for the case of linear cost-cap functions, a closed form solution of the optimal capacities in terms of the flows is available. In particular it was shown that:

$$C_i = f_i + \left(\frac{\sum_k \sqrt{d_k f_k}}{\sqrt{T_{\max}}} \right) \sqrt{\frac{f_i}{d_i}}$$

$$D = \sum_i (d_i f_i + d_{i0}) + \frac{(\sum_i \sqrt{d_i f_i})^2}{\gamma T_{\max}}$$

where: $d_i(C_i) \triangleq d_i C_i + d_{i0}$

C_i : optimal capacity on channel i

D : cost of the optimal capacities assignment.

If we introduce such expressions in Problem (5.1), we obtain a new formulation:

Problem (5.6)

given: topology

requirement matrix R

* Assuming that C is a continuous variable, the nonconvexity of $T(\underline{f}, \underline{C})$ can be easily proved by computing the quadratic form of the second partial derivatives and verifying that it is not positive semidefinite.

$$\underset{\underline{f}}{\text{minimize}} \quad D(\underline{f}) = \sum_i (d_i f_i + d_{i0}) + \frac{\left(\sum_i \sqrt{d_i f_i}\right)^2}{\gamma_{\max}^T}$$

constraint:

\underline{f} is a m.c. flow satisfying R

Problem (5.6) is a nonlinear, unconstrained m.c. flow problem.

The following theorem holds:

Theorem (5.7)

The function $D(\underline{f})$:

$$D(\underline{f}) = \sum_i (d_i f_i + d_{i0}) + \frac{\left(\sum_i \sqrt{d_i f_i}\right)^2}{\gamma_{\max}^T}$$

is concave with respect to $\underline{f} \in \underline{F}$, where \underline{F} is the set of feasible m.c. flows. The proof can be found in [GERL 73].

A corollary to Theorem (5.7) establishes an important property of local minima for the linear cost-cap case.

Corollary (5.17)

If $\bar{\underline{f}}$ is a local minimum of Problem (5.6), then $\bar{\underline{f}}$ is a shortest route flow.*

Proof

As $D(\underline{f})$ is concave and the set of feasible flows \underline{F} is convex, local minima are extreme points of \underline{F} , i.e., extremal flows, and therefore shortest route flows [GERL 73].

*A shortest route flow is a m.c. flow whose routes are shortest routes computed for a well-defined assignment $\{\ell_i\}$ of lengths to the arcs [HU 69].

Figure 5.4.1 illustrates the nature of $D(\underline{f})$; for convenience of representation, we assume that the feasible set \underline{F} is two-dimensional. Another important consequence of the concavity of $D(\underline{f})$ is that, in the application of the FD method [FRAT 73] to Problem (5.6), the step size λ of every flow deviation is equal to 1 (i.e., if we find a downhill direction, we go all the way down).

These and other properties will be further discussed in Section 5.6, where an FD algorithm for the solution of Problem (5.6) is introduced.

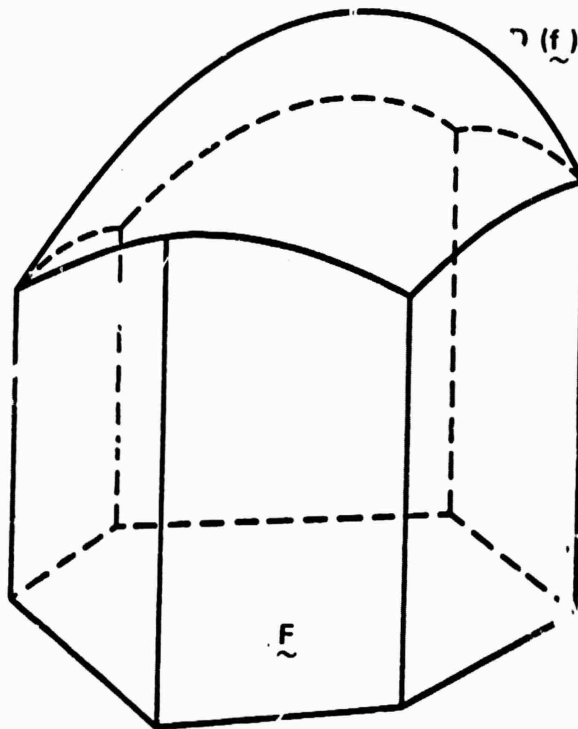

Figure 5.4.1. Concavity of $D(\underline{f})$

* FD refers to an algorithm known as the Flow Deviation Algorithm; See Section 5.6.

5.5 Concave Cost-Cap Functions

In the concave cost-cap case it is not possible, in general, to express the cost of the optimal capacities assignment D explicitly in terms of the flow \underline{f} ; therefore a formulation as nice as that in Problem (5.6) is not available. However, we can still show that $D(\underline{f})$ is concave.

Theorem (5.18)

The cost $D(\underline{f})$ of the optimal capacities assignment under concave cost-cap functions and under the constraint $T \leq T_{\max}$, is concave with respect to \underline{f} .

The proof can be found in [GERL 73].

The properties that were established in Section 5.4 for the linear cost-cap case (local minima \equiv shortest route flows; optimal FD step size $\lambda = 1$, etc.) apply also to the concave cost-cap case.

In Section 5.6 an algorithm for the solution of Problem (5.1) is introduced.

5.6 The FD Algorithm for the Solution of the Linear and Concave Cost-Cap Case

We now introduce an FD algorithm for the solution of Problem (5.1) for linear and concave cost-cap functions.

Algorithm (5.21)

0. Let $\underline{f}^0 \in \underline{F}$ and let \underline{C}^0 be the optimal assignment at $\underline{f} = \underline{f}^0$ (i.e., $D(\underline{C}^0) = \min D(\underline{C})$, s.t. $T(\underline{f}^0, \underline{C}) \leq T_{\max}$)
 Let $D_0 = D(\underline{C}^0)$
 let $n = 0$

1. Let $D_{\ell}^{(n)}(\underline{f})$ be the cost of the optimal cap assignment, as a function of the flow \underline{f} , for the problem linearized around $\underline{C} = \underline{C}^n$. Let $\underline{f}^{n+1} \triangleq$ shortest route flow corresponding to the metric $\ell_k^n \triangleq \left[\frac{\partial D_{\ell}^{(n)}(\underline{f})}{\partial f_k} \right]_{\underline{f}=\underline{f}^n}$.*
2. Let $\underline{C}^{n+1} \triangleq$ optimal assignment at \underline{f}^{n+1} , and $D_{n+1} \triangleq D(\underline{C}^{n+1})$.
3. If $(D_n - D_{n+1}) < \delta$, where δ is a proper positive tolerance, stop: $(\underline{f}^{n+1}, \underline{C}^{n+1})$ is a local minimum. Otherwise, let $n = n + 1$; go to 1).

The convergence of the algorithm is guaranteed by the fact that there are only a finite number of shortest route flows, and repetitions of the same flow are not possible, as D_n is strictly decreasing.

The partial derivatives used for the shortest route computation have the following expression (see Problem (5.6)):

$$\ell_k^n = \frac{\partial D_{\ell}^{(n)}(\underline{f})}{\partial f_k} = d_k \left(1 + \frac{\sum_i \sqrt{d_i f_i}}{\gamma_{\max}} \cdot \frac{1}{\sqrt{d_k f_k}} \right) \quad (5.22)$$

where d_k is the slope of the cost-cap curve for the k^{th} channel, evaluated at $C_k = C_k^n$. Notice that $\ell_k^n \geq 0$; negative loops cannot exist. Also notice that:

$$\lim_{f_k \rightarrow 0} \ell_k^n = \infty$$

* Notice that the metric ℓ_k^n varies at each iteration.

which means that whenever the flow (and therefore the capacity) of arc k is reduced to zero at the end of an FD iteration, then flow and capacity will remain zero for all subsequent iterations, as the incremental cost of restoring the flow ($\equiv \ell_k$) is infinity.*

This property suggests a method for the design of the topology: we can start from a topology which is highly connected, and eliminate arcs with the FD method, until a suboptimal configuration is obtained.

The FD method leads to a local minimum, which depends on the choice of the starting flow \tilde{f}^0 . In order to find several local minima, a mechanism that produces a large variety of starting flows is required. We propose the following randomized procedure for the generation of starting flows:

1. Assign initial equivalent lengths $\{\ell_i^0\}$ to the arcs at random.
2. Compute the shortest route flow \tilde{f}^0 according to the metric $\{\ell_i^0\}$.

The initial random choice of the lengths guarantees the randomness of the starting flows, thus providing a method for finding several local minima.** After a convenient number of iterations, the

* In the case of concave link costs $d_k(C_k)$ such that $d_k'(0) = +\infty$ (e.g., power law function), we have that, when $f_k \rightarrow 0$, $d_k \rightarrow \infty$. It is evident, from Equation (5.22), that this effect strengthens the tendency $\ell_k \rightarrow \infty$ for $f_k \rightarrow 0$.

** Another procedure for the exploration of local minima is found in Yaged [YAGE 71] and can be briefly summarized as follows. Once a local minimum corresponding to a given vector ℓ of equivalent lengths is obtained, a new vector $\tilde{\ell}'$ is generated by artificially perturbing

global minimum is chosen as the minimum of the local minima. This provides a "suboptimal" solution.

We chose the randomized procedure, rather than more ad hoc techniques (like the one proposed by Yaged), because we believe that it guarantees a more uniform and complete sampling of the solution space. Theoretically, all the local minima will be explored, if an infinite number of starting solutions is generated. We feel that ad hoc techniques tend to determine locals which are clustered in a relatively limited region.

A block diagram of the suboptimal procedure can be found in Figure 5.6.1, and a graphical interpretation is given in Figure 5.6.2.

5.8 Channel Costs

The set of channel capacities available for ARPA is discrete: Table 5.8.1 contains the list of capacity options and corresponding costs considered in the present application [KLEI 70].

In order to apply continuous techniques, we approximate the discrete cost-cap curves with continuous, power law curves:

$$d_i(C_i) = d_i C_i^{\alpha_i} + d_{i0} \quad (5.30)$$

Other concave approximations could be considered [KLEI 70], however, the power law curves are particularly convenient for the property that local min are global min in the solution of the capacity assignment problem [KLEI 70].

some components of $\underline{\ell}$. Let f' be the shortest flow associated to $\underline{\ell}'$, and apply the FD method with \tilde{f}' as a starting flow: a new local minimum is, in general, obtained. The procedure is applied several times, and several locals are found.

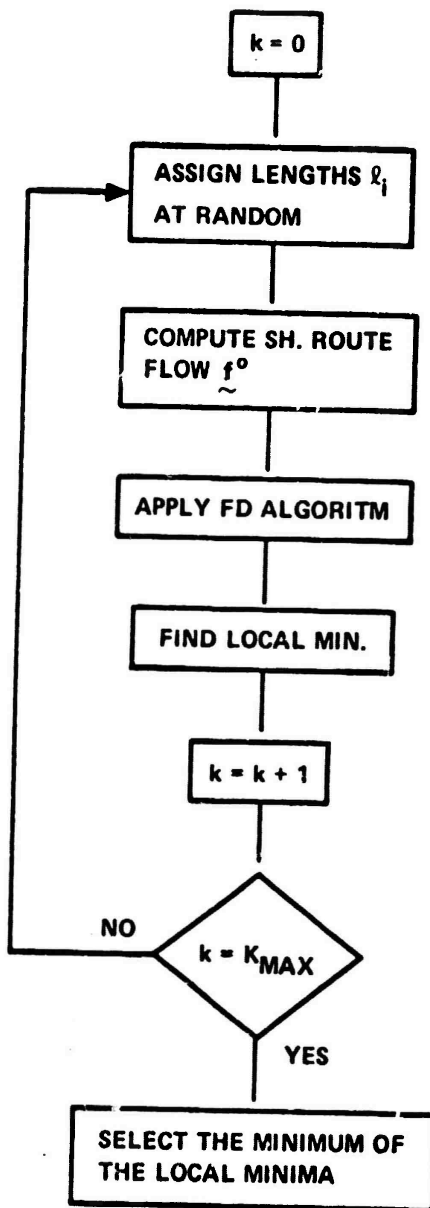

Figure 5.6.1. Block Diagram of the Random Procedure for the Determination of a Suboptimal Solution.

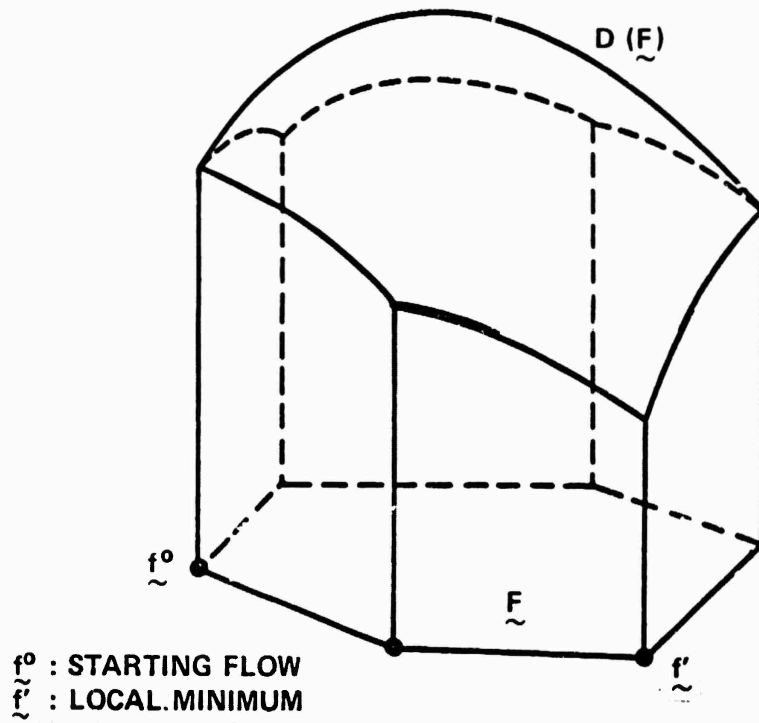

Figure 5.6.2. Illustration of the FD Method.

Discrete channel costs, as from Table 5.8.1, and power law

TABLE 5.8.1
CHANNEL CAPACITIES AND CORRESPONDING
COSTS USED IN THE OPTIMIZATION

Capacity [kbits/sec]	Termination Cost [\$ /month]	Line Cost [\$ /month/mile]
9.6	650	.40
19.2 (2 x 9.6) *	1300	.80
19.2	850	2.50
50	850	5.00
100 (2 x 50) *	1700	10.00
230.4	1350	30.00

Note: The total cost per month of a channel is given by:

$$\text{total cost} = \text{termination cost} + (\text{line cost}) \times (\text{length in miles})$$

* Options obtained by using lower capacities in parallel.

approximations for six different line lengths, are plotted in Figures 5.8.2a and 5.8.2b. We do not discuss the details of the determination of the parameters in Equation (5.30), but merely mention that the terms d_{i0} were made zero and the other parameters were chosen so that the continuous curves would interpolate the discrete costs.

The difference between continuous and discrete costs, in correspondence to the discrete capacity values, is relatively small, if

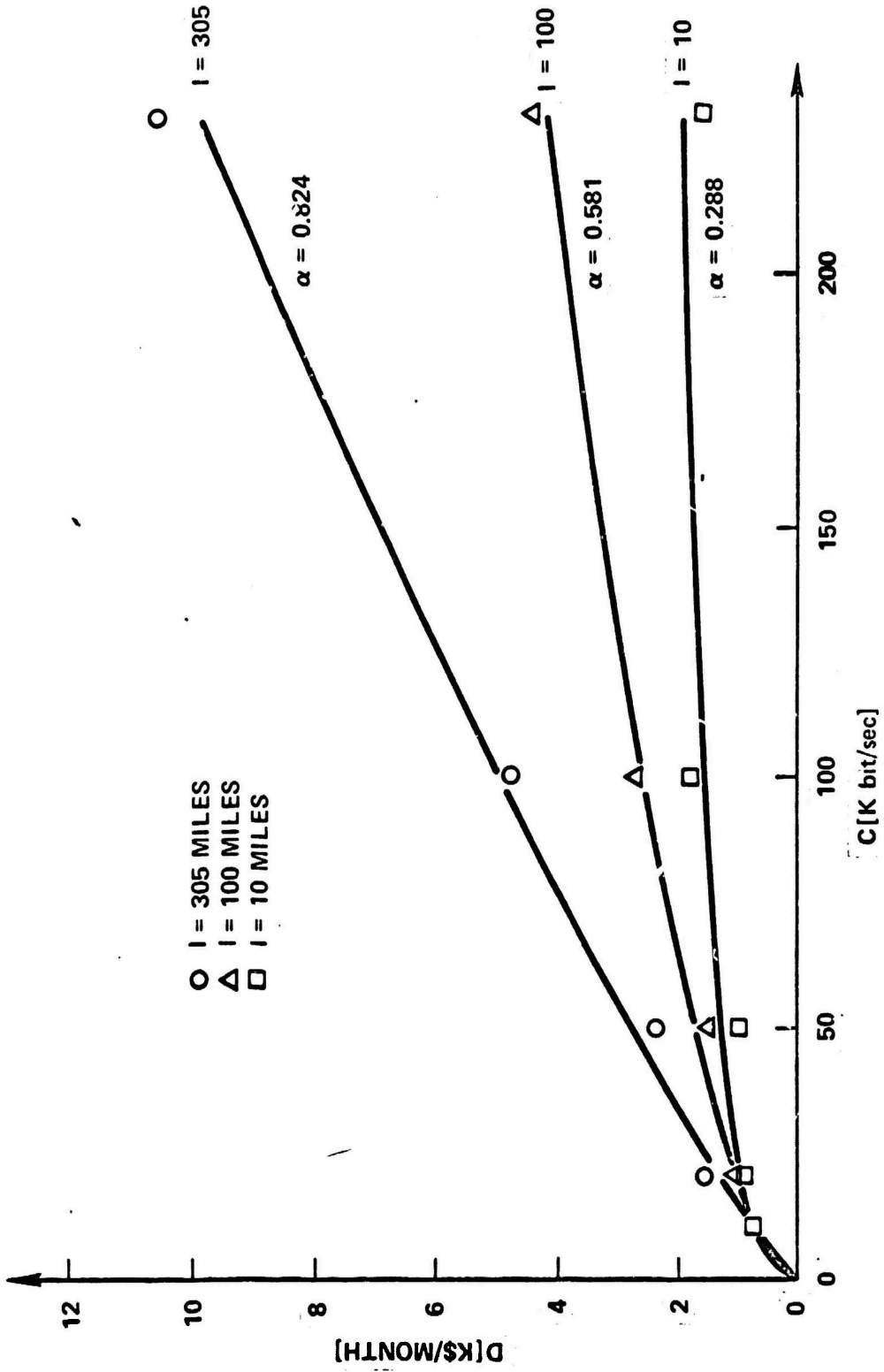

Figure 5.8.2a. Power Law Approximation of Discrete Channel Costs (Part 1).



Figure 5.8.2b. Power Law Approximation of Discrete Channel Costs (Part 2).

we exclude the case $C = 230$ [kbits/sec] for line lengths ≥ 1000 miles,* in which the discrete cost is about 20% higher than the continuous cost: in any case we can very reasonably assume that the optimal continuous solution of the CFA problem is a lower bound on any discrete solution.

Notice that the exponent α varies with the line length: for line lengths between 0 and 750 miles, α varies between 0.2 and 1.00; for lengths ≥ 750 miles the value $\alpha = 1.00$ is chosen. We found experimentally that in the ARPA Network, due to the geographical location of the nodes, 70% of the total cost is represented, on the average, by arcs with length ≥ 300 miles, i.e., arcs for which $\alpha > 0.8$. We can expect, therefore, that the solutions obtained with the above power law approximation will exhibit properties which are similar to those of the solutions obtained considering power law curves with uniform $\alpha = 0.8 \div 0.9$.

In order to study the behavior of the solutions for different economies of scale [YAGE 71], we also consider applications with uniform α power law curves:

$$d_i(C_i) = \frac{D_{i0}}{C_0} C_i^\alpha \quad (5.31)$$

where

$$C_0 = 50 \text{ [kbits/sec]}$$

$$D_{i0} = \text{cost of 50 kb option for arc } i .$$

*This case is of little practical interest for our applications anyway, because we found experimentally that, with the values of requirement currently used. No good design would assign such large capacities to such long links.

CHAPTER 6

TOPOLOGICAL DESIGN

6.1 Introduction

In this chapter we study the problem of minimizing the cost of a S/F communication network, when topology, routing of the flows and capacity assignment are all considered to be variable.

The exact solution of such a problem for large networks is computationally prohibitive even with the largest computers available today; our intention, therefore, is to develop heuristic algorithms for the determination of good, suboptimal solutions.

In Section 6.2 we give the formulation of the problem.

In Section 6.3 we review the existing techniques for the topological design and introduce the Concave Branch Elimination (CBE) method as an alternative to existing techniques, for the particular case of networks with a concave objective function.

In Section 6.4 the CBE method is applied to the linear and concave cost-cap case, and several examples are presented.

In Section 6.5 we discuss an efficient technique for preserving the 2-connectivity of the solutions.

In Section 6.6 the CBE method is applied to the discrete capacities problem; some additional heuristics are discussed and several examples are presented.

In Section 6.9 we give some concluding remarks and an evaluation of the CBE method as compared to other topological approaches.

6.2 The Topological Problem

Problem (6.1)

given: requirement matrix R

cost-cap functions $D_i = d_i(C_i)$, $\forall i$

minimize: $D(A, C) = \sum_{i \in A} d_i(C_i)$
over A, C, f

where A is the set of arcs which corresponds to a specific topology*

s.t.: (a) f is a m.c. flow satisfying the requirement matrix R

(b) $f \leq C$

(c) $T = \frac{1}{\gamma} \sum_{i \in A} f_i \left[\frac{1}{C_i - f_i} \right] \leq T_{\max}$

(d) The set A must correspond to a 2-connected topology [FRIS 67]

* Here it is assumed that A is a subset of the set of arcs corresponding to a fully connected network, in which multiple links and self loops are excluded.

6.3 Review of Topological Design Methods for Networks.
Introduction of the Concave Branch Elimination (CBE) Method.

As we already mentioned in Chapter 5, the topology is a variable of combinatorial type and the exact solution of the topological problem requires the exploration of a large number of topologies (in the limit all possible combinations); as a consequence, the amount of computation increases exponentially with the number of nodes. We believe that the exact solution is computationally prohibitive already for networks on the order of ten nodes, and that only good heuristic solutions can be found in a reasonable computational time for networks of larger size.

Several examples of heuristic solutions to large topological problems can be found in the literature. In [LIN 65], Lin describes a suboptimal algorithm for the solution of the Traveling Salesman Problem; the algorithm is based on the random generation of several hamiltonian circuits, which are successively improved by means of topological transformations, involving only three arcs at a time, until a local minimum is obtained. The minimum of the local minima is the heuristic solution to the problem. Lin applied the algorithm to a variety of examples, for which the exact solution was known, and found the exact solution for all of them!

A similar approach is used by Frank et al. for the determination of the minimum cost topology of a pipeline network connecting gas fields to separation plants in the Gulf of Mexico [FRAN 69]. The network is assumed to have a tree structure, and the algorithm consists of the random generation of several different trees, whose cost is

successively reduced by topological transformations, in which arcs are added and deleted one at a time. A very efficient dynamic programming algorithm finds the optimal capacities which yield the minimum cost for the new topology obtained after each transformation.

Frank et al. applied the same dynamic programming approach to the design of centralized computer networks [FRAN 71A].

A heuristic approach to the design of minimum cost survivable networks is described by Steiglitz et al. in [STEI 69]. The method consists of a starting routine, which generates random feasible topologies, and of an optimizing routine, which improves the cost of the starting topology by means of local transformations, called X-changes. An X-change corresponds to the deletion of two arcs, say (i, m) and (j, ℓ) , and the introduction of two new arcs (i, ℓ) and (j, m) . The practicality of the algorithm is based on a very efficient technique for testing the feasibility of the new topology after each X-change [KLET 69].

A heuristic method for the design of minimum cost, 2-connected computer networks is proposed by Frank et al. in [FRAN 70]. The approach is similar to that described in [STEI 69], and applies the same techniques for random generation of topologies and topological transformations. In addition, a very efficient heuristic routing algorithm is developed.

Common features of the above heuristics are: random generation of several starting topologies (which ensures wide sampling of the solution space); availability of fast and efficient techniques for the evaluation of each topology.

Less sophisticated heuristics do not apply the randomization

of the starting topology: to such a category belong several techniques recently proposed for the design of minimum cost centralized computer networks [MART 67, ESAU 66, WHIT 72B]. Typically, the suboptimal configuration is obtained after the repeated application of simple topological operations (e.g., insertion, deletion or replacement of a branch, etc.). An interesting evaluation of some of the methods, as compared to the optimal solution, is presented by Chandy and Russel in [CHAN 72B].

We might classify all the above methods as branch-exchange, or branch-insertion methods: branches are systematically exchanged or inserted, following some well defined criteria.

In the special case of a multicommodity flow network, in which the objective to minimize is a concave function of the flows, another heuristic method can be proposed as an alternative (or as a complement) to the branch-exchange methods. The method is based on the property that the flow patterns, which are local minima of the CFA problem, typically concentrate the flows on some links, and leave some other links with zero flow (see Chapter 5): the initial topological configuration is therefore automatically reduced in the process of finding local minima. We will refer to such topological reduction, induced by concavity, as Concave Branch Elimination (CBF).

The CBE method consists of two routines: the random starting routine, which generates several random starting topologies and, for each topology, several random starting flow configurations; the optimizing routine, which improves a given starting topology with progressive "concave elimination" of expensive arcs, until a local minimum is reached.

The random starting routine must generate initial topologies which are likely to contain the optimal topology as a subgraph, and, at the same time, that can be conveniently processed by the optimizing routine. In the choice of such initial topologies, the human interaction can be very useful; in fact, in many examples introduced later in the chapter, the initial topologies were generated by hand. A method for the automatic generation of initial topologies is outlined in Section 6.8.

The idea of using concave branch elimination for the topological design of networks, with concave link costs and multicommodity flow requirement, is not new. Yaged in [YAGE 71] applies such an approach to the determination of minimum cost topologies for a large telephone network, where the total cost is the sum of the concave link costs; several minimum cost topologies (corresponding to different link costs) are obtained, starting from a common, highly connected, planar topology (which is implicitly assumed to contain all minimum cost topologies as subgraphs).

The CBE method here proposed is a generalization of Yaged's technique: it applies to nonseparable objective functions and guarantees a wider sampling of the solution space, through the random generation of initial topologies and initial flow assignments.

The CBE method is, therefore, applicable to the topological design of S/F networks, as we showed in Chapter 5 that the CFA problem leads to the minimization of a nonseparable concave objective function.

6.4 Concave Cost-Cap Case Without the 2-Connectivity Constraint

In the present section we assume that the cost-cap functions are linear or concave; we also relax the 2-connectivity constraint.

With the above assumptions, Problem (6.1) can be regarded as a capacity and flow assignment problem (see Section 5.4) in which the initial topology is fully connected: the CBE method, therefore, reduces to the FD method. In some applications (typically, the applications with moderate concavity of the cost-cap functions) the fully connected starting net produces very satisfactory results. In some other applications (pronounced concavity of the cost-cap functions and, in the limit, presence of start up costs), a fully connected start leads typically to locals, which are very far from optimum. For the latter applications, the CBE method is greatly improved by selecting initial topologies, which are likely to contain the optimal topology and which exclude, on the other hand, obviously bad links. For networks on the order of 20 to 50 nodes, a large sample of good initial topologies can be generated by hand. For larger networks, the generation can be done with the aid of the computer [GERL 73].

The CBE method has been applied to the design of topologies connecting 26 ARPA sites (see Figure 6.4.1). Several concave channel costs have been considered (α fitted; uniform $\alpha = 1.0, 0.8, 0.6, 0.5, 0.1$),^{*} The traffic requirement r was assumed uniform (in some cases, $r = 1.0$ [kbits/sec]; in some others $r = 0.74$ [kbits/sec]). A maximum delay $T_{\max} = .200$ was required. For each value of α several initial

^{*} See Section 5.8 for the analytical expression of the channel costs.

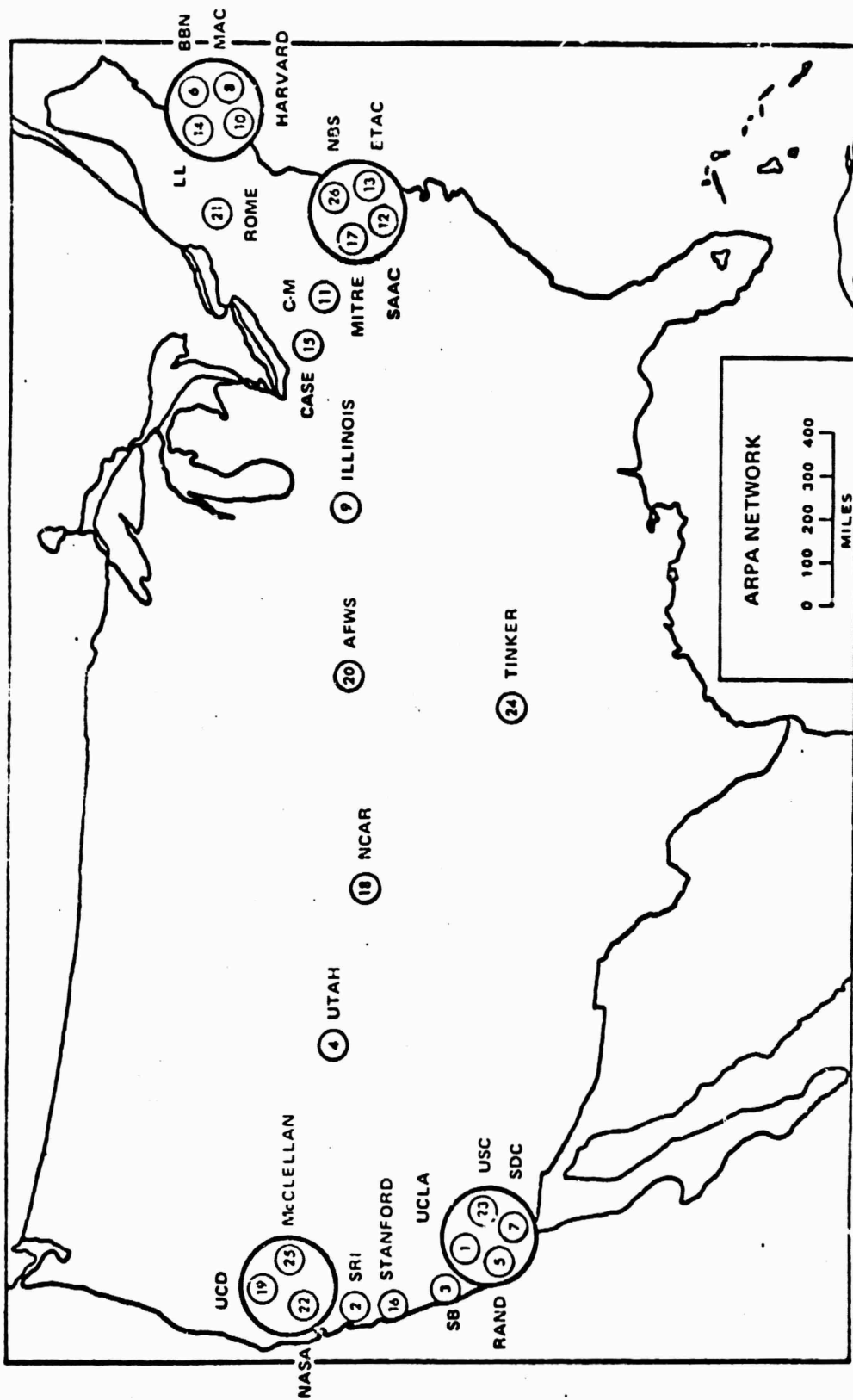

Figure 6.4.1 26 ARPA Sites

topologies were considered; for notational convenience we classify them in the following way:

- fully connected (325 arcs)
- highly connected (above 40 arcs)
- medium connected (30-40 arcs)
- low connected (26-29 arcs)
- trees (25 arcs)

Notice that the arcs are nondirected (i.e., each arc corresponds to two directed arcs, with opposite directions, and is physically implemented with a full duplex channel).

A summary of the results is shown in Tables 6.4.2a and 6.4.2b. The results are subdivided into six classes, each class corresponding to a different value of α . For each CBE application we give:

- degree of connection: it defines the type of initial topology considered (e.g., fully connected, minimum spanning tree, * shortest hamiltonian, etc.).
- NA_0 : number of arcs of initial topology.
- NLOC: number of local minima explored.
- D_1, NA_1 : cost (\$/month) and number of arcs of the best local minimum.
- D_2, NA_2 : cost (\$/month) and number of arcs of the second best local minimum.

An accurate analysis of the results permits us to establish interesting properties of the suboptimal solutions. Some of these

*The minimum spanning tree was computed with link lengths proportional to the geographical distances.

TABLE 6.4.2a

RESULTS OF THE CBE METHOD, WITH CONCAVE COST CURVES
AND NO 2-CONNECTIVITY CONSTRAINT

α fitted, $r = 1.0$ [kbits/sec x node pair]

Degree of connection	NA_0	NLOC	D_1	NA_1	D_2	NA_2
fully conn.	325	30	82,583	55	82,961	52
highly conn.	53	30	81,202	40	81,979	39
highly conn.	52	30	81,988	40	82,077	42
med. conn.	35	30	82,606	30	82,743	30
med. conn.	33	30	84,719	30	84,721	30
sh. hamilt.	26	30	94,977	26	94,977	26
min. sp. tree	25	1	91,775	25	-	
tree 2	25	1	95,456	25	-	

$\alpha = 1.0$, $r = 0.74$ [kbits/sec x node pair]

Degree of connection	NA_0	NLOC	D_1	NA_1	D_2	NA_2
fully conn.	325	30	62,459	52	64,079	52
highly conn.	40	30	62,029	39	62,062	39

$\alpha = 0.8$, $r = 0.74$ [kbits/sec x node pair]

Degree of connection	NA_0	NLOC	D_1	NA_1	D_2	NA_2
fully conn.	325	30	65,439	34	65,443	39
highly conn.	40	30	62,751	34	62,922	35
min. sp. tree	25	1	65,073	25	-	

TABLE 6.4.2b

RESULTS OF THE CBE METHOD, WITH CONCAVE COST CURVES
AND NO 2-CONNECTIVITY CONSTRAINT

$\alpha = 0.6, r = 1.0$ [kbits/sec x node pair]

Degree of connection	NA ₀	NLCC	D ₁	NA ₁	D ₂	NA ₂
fully conn.	325	50	71,233	27	72,325	27
highly conn.	40	30	65,834	27	70,291	31
med. conn.	33	30	68,780	28	68,821	27
min. sp. tree	25	1	66,207	25	-	
tree 2	25	1	65,158	25	-	

$\alpha = 0.5, r = 1.0$ [kbits/sec x node pair]

Degree of connection	NA ₀	NLOC	D ₁	NA ₁	D ₂	NA ₂
highly conn.	53	50	64,421	26	65,012	27
highly conn.	40	30	60,712	26	63,117	28
med. conn.	32	50	63,582	27	67,088	28
min. sp. tree	25	1	60,505	25	-	
tree 2	25	1	59,719	25	-	

$\alpha = 0.1, r = 0.74$ [kbits/sec x node pair]

Degree of connection	NA ₀	NLOC	D ₁	NA ₁	D ₂	NA ₂
fully conn.	325	30	64,100	25	65,575	25
highly conn.	40	30	48,040	25	49,821	25
med. conn.	33	30	47,711	25	49,476	25
min. sp. tree	25	1	42,601	25	-	
tree 2	25	1	43,003	25	-	

properties were already pointed out in Chapter 5. In addition, some new properties, which relate the topological characteristics of the solutions to the input parameters, were observed. The properties can be summarized as follows:

(a) When α decreases (i.e., the economy of scale increases), the number of arcs of the suboptimal solution decreases. In fact, for $\alpha = 1.0$ and α fitted, good topologies have a number of arcs varying from 30 to 60; topologies with higher or lower numbers of arcs exhibit poor performance (as in the case of the two trees or the shortest hamiltonian circuit, for α fitted). For $\alpha = 0.8$, the optimal number of arcs seems to be between 40 and 30. For $\alpha \leq 0.6$, all of the best solutions that we found had a tree structure.

(b) When α decreases, the range of variation of NA (final number of arcs) for the good suboptimal topologies becomes smaller. We already mentioned that, for $\alpha = 1$, many good solutions have NA between 60 and 30. For $\alpha = 0.1$, the good topologies all have a tree structure (NA = 25).

(c) When α decreases, the range of variation of the costs within each run becomes larger (we already observed this property in Chapter 5). Considering the distribution of the costs of the local minima obtained from a given initial topology, we noticed that, for α fitted and $\alpha = 1.0$, more than 30% of the costs were within 2-3% of the best cost for that run. For $\alpha = 0.6$ and $\alpha = 0.5$, only 10-20% of the costs were within 10% of the best. The spread of the distribution of the costs was increasing with the degree of connection of the initial topology, and was maximum for the fully connected topology.

(d) When α decreases, the range of variation of the costs obtained from different runs (i.e., using different initial topologies) becomes larger. For α fitted, all the initial topologies with $NA_0 \geq 35$ produced solutions in a 2% range. For $\alpha = 0.6$ and 0.5 , the fully connected start produced poor results; other initial topologies, with NA_0 between 50 and 25, gave solutions in a 5-10% range. For $\alpha = 0.1$, initial topologies with NA_0 between 30 and 40 produce solutions with costs which are 15% higher than the cost of the minimum spanning tree (which is the exact solution for $\alpha \rightarrow 0$).

Properties (a) and (b) can be attributed to the fact that small α corresponds to strong economy of scale and favors topologies with large capacities concentrated in a few arcs. Properties (c) and (d) are a consequence of the fact (already mentioned in Chapter 5) that, when α decreases, the number of local minima increases and the costs of such local minima are widely diversified (see Figure 6.4.2C).

This fact also explains the performance of different initial topologies for different values of α . Highly connected (h.c.) topologies are more likely to contain the optimal topology, as a local minimum, than low connected (l.c.) topologies; on the other hand, for the same value of α , h.c. topologies contain a much larger number of local minima (we conjecture that such a number increases exponentially with NA_0). For $\alpha = 0.8-1.0$, h.c. topologies offer a good probability of obtaining, if not the optimal solution, at least very good solutions, because the number of local minima is relatively small, and the values of the minima are close; l.c. topologies, on the other hand, restrict arbitrarily the set of solutions to a region which might be far from

optimum. For small α , the number of local minima is so large (for $\alpha \rightarrow 0$, all extreme flows are stationary flows), and their values are so diversified that h.c. topologies lead usually to bad locals; carefully chosen l.c. topologies can perform better, as they eliminate many bad locals.

The above considerations indicate that the CBE method is very useful for applications with $\alpha = 0.8-1.0$: the choice of the initial topology is not very critical, and the exploration of a few local minima gives, in general, already good solutions. In the range of $\alpha = 0.5-0.8$, the CBE method can still be applied, but a careful choice of the initial topology (see [GERL 73]) and the exploration of a large number of locals are advisable. For $\alpha < 0.5$, the CBE method seems to be of little use. This does not mean that we cannot find good solutions for small α ; in fact, as we showed, the good solutions have a tree structure and therefore the topological problem corresponds to the problem of finding the minimum cost tree that satisfies $T \leq T_{\max}$. Notice that, for a tree, the routing assignment is unique, therefore, given the tree, we can compute immediately f , C and $D(C)$. The efficiency with which we can evaluate $D(C)$ for new topologies suggests the use of a branch X-change method for the search of the minimum cost tree [STEI 69, FRAN 70]. As an alternative approach, one could determine several local minima with the CBE method, and then improve them with branch X-change techniques. The simple inspection of two solutions obtained from a highly connected topology, with $\alpha = 0.1$ (see Figures 6.4.3 and 6.4.4) suggests that a few branch X-changes could considerably reduce the cost.

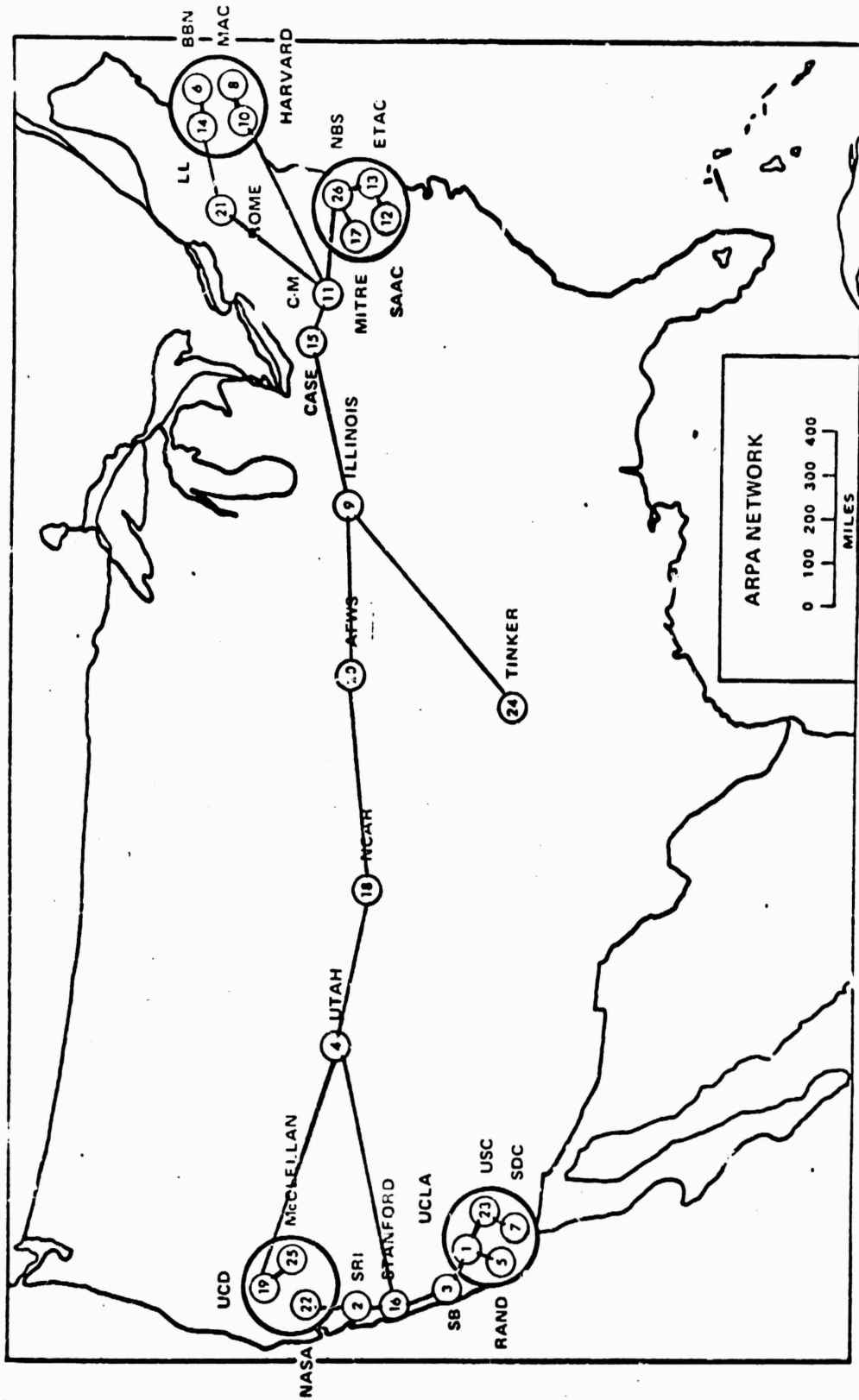

Figure 6.4.3 Local Solution for $\alpha = 0.1$; $D = 47,711$

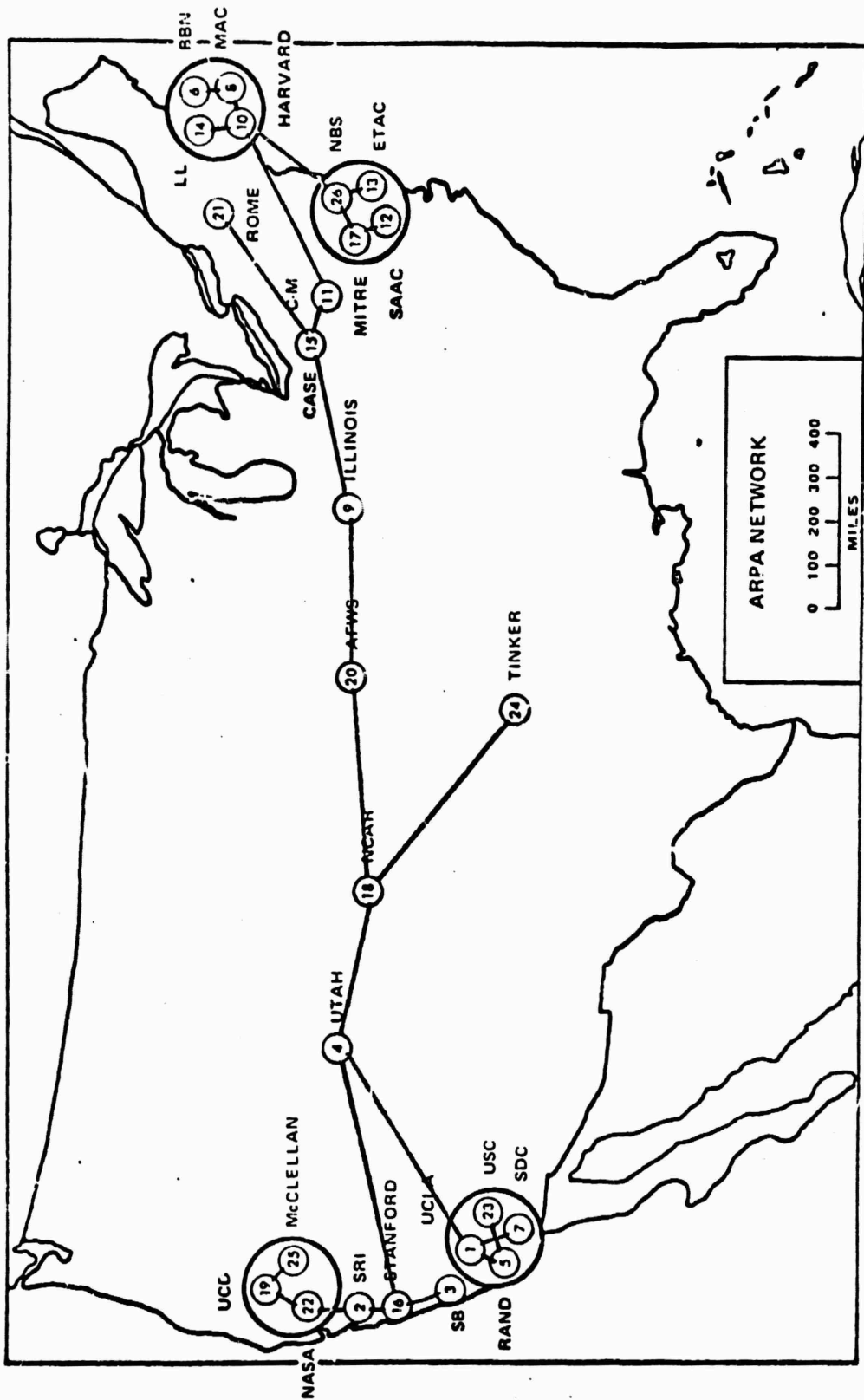

Figure 6.4.4 Local Solution for $\alpha = 0.1$; $D = 48,040$

Until now we have discussed the dependence of the results upon the characteristics of the cost function $D(f)$. We expect that the results should depend also on the degree of "balance" of the traffic requirement; on the total thruput; on the number of nodes NN ; on their geographical distribution, etc. A rigorous investigation of such dependence would require the study of a large number of different cases. Here we limit ourselves to some simple considerations.

We can intuitively expect that a highly unbalanced requirement would drive the optimal topology to a tree: such expectation is motivated by the fact that, for multiterminal, centralized networks (i.e., $c_{ij} = 0 \forall i, j$, except for $i = C$, or $j = C$, where C is the "central" node), the optimal topology is a tree [ZANG 68].

Also, we would expect that a uniform geographical distribution* of the nodes tends to level off the differences in cost between the various topologies obtained with the CBE method. Consider, as an example, the two very different node distributions shown in Figure 6.4.5 (a) and (b). Suppose that we want to determine the optimal topologies for both distributions, using the CBE method and assuming concave link costs, with $\alpha \rightarrow 0$ (see Equation (5.31)). Let us also assume that, as initial topologies for the CBE method, the two very reasonable planar topologies of Figure 6.4.5 (a) and (b) are used. The well known exact solutions are the minimal spanning trees. Such minimal trees, as well as many other trees, can be generated from the initial topologies by the CBE method. Notice, however, that any spanning tree for topology (a) is minimal; on the other hand, notice that, for topology (b), ma

* Here we assume that the link costs are related to the geographical lengths. More generally, the regularity of the cost matrix should be considered.

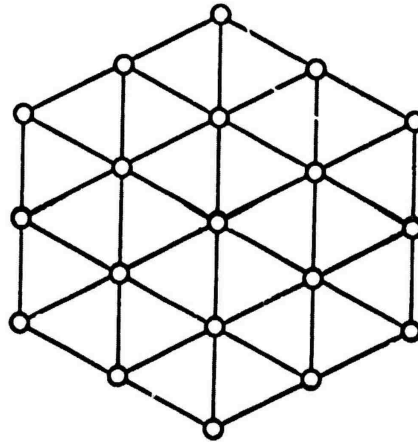

(a) UNIFORM GEOGRAPHICAL DISTRIBUTION OF THE NODES

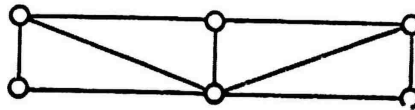

(b) IRREGULAR NODE LOCATION

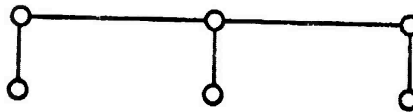

(c) MINIMUM SPANNING TREE FOR TOPOLOGY (b)

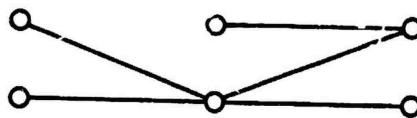

(d) ANOTHER SPANNING TREE FOR TOPOLOGY (b)

Figure 6.4.5. Impact of Geographical Node Location on the Topological Design.

spanning trees (see, for example, the tree in Figure 6.4.5 (a)) have a much higher cost than the minimal spanning tree (c). We conclude that the application of the CBE method, with $\alpha \rightarrow 0$, is successful for topology (a) and disastrous for (b). This example is clearly an extreme case, but it motivates our expectation that the CBE method can handle uniform node distributions better. These considerations might also help to understand why Yaged, having a fairly uniform node distribution (see [YAGE 71]), obtained much better results* for very small α , than we did with the 26 ARPA sites, which are more irregularly distributed.

Finally, as an example of the relation between optimal topological structure and thruput, we can consider the case of link costs represented by the contribution of a set up cost plus a cost which is linearly increasing with the capacity. For small thruput, the set up cost is predominant, and the optimal solutions are trees. For large thruput, the variable cost is predominant, and the optimal solutions are highly connected topologies.

6.5 The 2-Connectivity Constraint

A very important requirement for a communications network is the survivability to failures: the network must remain operational (i.e., nodes must be able to communicate with each other) even after the failure of n elements (nodes or arcs). It can be shown [FRIS 67] that a network, in order to survive to $n - 1$ arbitrary failures, must

*Yaged claims, in [YAGE 71], that, starting from a highly connected planar topology and applying concave branch elimination techniques, he could generate, in the case $\alpha \rightarrow 0$, the exact solution, i.e., the minimum spanning tree.

provide n independent paths (i.e., with no common intermediate nodes or arcs) between each pair of nodes; the network is then referred to as n -connected.

Usually, computer networks are considered to be sufficiently reliable if they survive one simple failure at a time [ROBE 70]; for that reason, only 2-connectivity is required in the formulation of Problem (6.1).^{*} However, many of the considerations that follow can be applied to the general n -connectivity case.

Very efficient techniques were recently developed for the analysis of the connectivity in communication networks [FRIS 67, KLET 69]. As for the design of minimum cost, n -connected networks, exact solutions are available only in the very special case of link costs which are merely set up costs and which are identical for all the links. A heuristic approach to the solution of the case of set up costs which are different from link to link has been discussed by Steiglitz et al. [STEI 69]: the approach utilizes the branch X-change technique, in which only X-changes that preserve n -connectivity and reduce the cost are accepted. The case of communication networks with link costs which depend on the capacity was considered by Frank et al. in [FRAN 70], in relation to the design of a 2-connected computer network; the method applies the branch X-change technique, in which a branch X-change is accepted only if it preserves 2-connectivity and improves the

* A more complete definition of survivability should include, in addition to 2-connectivity, the maximum tolerable degradation in performance (e.g., thruput or delay) when an element fails. However, the test of such degradation at each step of the design would represent too severe an overhead; therefore, it is more convenient to verify it a posteriori.

performance. The method is very similar to that of Steiglitz et al. in [STEI 69]; notice, however, that the evaluation of the cost after each X-change, while it is trivial for set up costs, is extremely difficult for costs which vary with the capacities, as it involves an optimal assignment of routing and capacities.

If the CBE method is applied to the design of minimum cost, 2-connected networks, the obvious way to obtain 2-connected solutions is to start from a 2-connected topology and to test 2-connectivity after each iteration; * the algorithm terminates when the test fails or when no improvement is obtained. In both cases, we retain the result of the iteration before the last.

The presence of the 2-connectivity requirement increases the cost of the optimal solution (if the optimal, unconstrained solution is not 2-connected). This effect can be seen in Tables 6.5.1 (a), (b) and (c), where the results with and without 2-connectivity test, obtained from various initial topologies, are compared.

Notice that, for α fitted, the degradation is not too severe (the constrained minimum for each run is within 2% of the unconstrained one); for $\alpha = 0.5$, on the other hand, the degradation is dramatic (the difference between constrained and unconstrained minimum is on the order of 20-30%). This is no surprise, as the good topologies for

*The 2-connectivity test can be implemented with a labeling algorithm, which requires from $(NN)^2$ to $(NN)^3$ elementary operations, depending on the degree of connection of the topology under consideration. The overhead due to the introduction of such a test is not too severe, if we consider that one shortest route computation alone requires $(NN)^3$ operations.

TABLE 6.5.1a

COMPARISON OF THE CBF RESULTS
WITH AND WITHOUT 2-CONNECTIVITY TEST

α fitted, $r = 1.0$ [kb/sec x node pair]

Example 1: fully connected initial topology ($NA_0 = 325$),
number of local minima NLOC = 30

No 2-connectivity test

D[K\$]	number of solutions
82 - 84	2
84 - 86	4
86 - 88	6
88 - 90	7
90 - 92	5
> 92	6

2-connectivity test present

D[K\$]	number of solutions
82 - 84	1
84 - 86	3
86 - 88	6
88 - 90	6
90 - 92	6
> 92	8

Example 2: highly connected initial topology ($NA_0 = 53$),
number of local minima NLOC = 50

No 2-connectivity test

D[K\$]	number of solutions
82 - 84	15
84 - 86	20
86 - 88	5
88 - 90	5
90 - 92	5
> 92	0

2-connectivity test present

D[K\$]	number of solutions
82 - 84	0
84 - 86	11
86 - 88	4
88 - 90	3
90 - 92	2
> 92	30

TABLE 6.5.1b

COMPARISON OF THE CBE RESULTS
WITH AND WITHOUT 2-CONNECTIVITY TEST

α fitted, $r = 1.0$ [kb/sec/node x pair]

Example 3: medium connected initial topology ($NA_0 = 32$),
number of local minima NLOC = 50

No 2-connectivity test

D[K\$]	number of solutions
88 - 90	50
90 - 92	0
92 - 94	0
94 - 96	0
96 - 98	0
> 98	0

2-connectivity test present

D[K\$]	number of solutions
88 - 90	2
90 - 92	12
92 - 94	6
94 - 96	16
96 - 98	10
> 98	4

TABLE 6.5.1c

COMPARISON OF THE CBE RESULTS
WITH AND WITHOUT 2-CONNECTIVITY TEST

$$\alpha = 0.5, \quad r = 1.0 \text{ [kb/sec} \times \text{node pair]}$$

Example 1: highly connected initial topology ($NA_0 = 53$),

number of local minima NLOC = 50

No 2-connectivity test

D[K\$]	number of solutions
64 - 68	7
68 - 72	3
72 - 76	16
76 - 80	12
80 - 84	2
> 84	0

2-connectivity test present

D[K\$]	number of solutions
64 - 68	0
68 - 72	0
72 - 76	0
76 - 80	0
80 - 84	1
> 84	49

Example 2: medium connected initial topology ($NA_0 = 32$),

number of local minima NLOC = 50

No 2-connectivity test

D[K\$]	number of solutions
62 - 66	1
66 - 70	30
70 - 74	19
74 - 78	0
78 - 82	0
> 82	0

2-connectivity test present

D[K\$]	number of solutions
62 - 66	0
66 - 70	0
70 - 74	16
74 - 78	34
78 - 82	0
> 82	0

α fitted tend to be highly connected, thus including a fairly large number of 2-connected configuration; for $\alpha = 0.5$, on the other hand, the good topologies tend to have a tree structure, and therefore 2-connectivity and low cost are contradictory design criteria. In general, for small α , low cost 2-connected configurations are difficult to locate with the CBE method.

The above results suggest that, in general, the CBE method plus 2-connectivity test is a good approach for the applications with moderate economy of scale ($\alpha = 0.8 - 1.0$ in our case). For applications with medium economy of scale ($\alpha = 0.6$), the CBE method should be combined with a branch insertion routine (see Section 6.8), which preserves 2-connectivity by introducing a proper set of arcs whenever the topology, during the CBE optimization, becomes monoconnected. For applications with very strong economy of scale (see, as a limiting case, the problem considered by Steiglitz et al. in [STEI 69]), branch X-change seems to be the only reasonable approach.

In order to be reliable, a 2-connected network must also be able to contain within acceptable limits the degradation in performance following a failure. For instance, if the links have no set up costs, any monoconnected solution can be made 2-connected by introducing appropriate links with infinitesimal capacity, without virtually increasing the cost: such a solution would obviously not meet the reliability requirements. The solutions obtained with the CBE method must be, therefore, a posteriori verified, to make sure that their reliability is acceptable. This additional reliability test, however, is not too critical for CBE solutions, for the following reasons:

- the final flow configuration is an extremal flow, therefore the capacity in each arc is $\geq \min \{r_{ij} \mid r_{ij} > 0\}$; this excludes pathological cases with infinitesimal capacities assigned to some arcs.
- the CBE method tends to eliminate arcs with small capacity, as their marginal cost is very high. Therefore, small capacities are not likely to be found in the final configuration.
- typically, the CBE method generates a large set of good solutions: it is very likely that some of them will meet the reliability requirement.

6.6 Discrete Cost-Cap Case

If the discrete channel costs can be reasonably approximated by continuous, concave costs $D_i(C_i)$, such that $D_i(0) = 0$ (i.e., no set up cost), then the topology (or, better, several good topologies) can be designed with the CBE method using the continuous approximation; from each of the continuous solutions a discrete capacity assignment can be derived with the techniques described in Chapter 5.

This continuous-discrete approach was applied to the topological design of a network connecting the 26 ARPA sites shown in Figure 6.4.1. The discrete costs are given in Table 5.8.1; as a continuous, concave approximation to such costs, we used the α fitted, power law curves described in Section 5.8. A uniform traffic $r = 1.0$ [kb/sec x node pair] is required. The delay $T_{\max} = 0.200$ [sec] is prescribed, as maximum admissible average delay.

In order to obtain 2-connected solutions, the CBE method with 2-connectivity test was applied. The degradation produced by the test was not too severe for α fitted (as shown in Section 6.5).

For the assignment of discrete capacities, the following approach was used:

- let \underline{f} be the flow of the continuous solution
- let \underline{C} be the minimum cost discrete capacities assignment such that $C_i \geq f_i$, $\forall i$ (minimum fit assignment)
- with assignment \underline{C} , let ρ be the maximum traffic level such that $T \leq T_{\max}$.

\underline{C} is the discrete capacities assignment and ρ is the traffic level associated with it; if $\rho \geq 1$, the solution is feasible. Experimentally, we found that with $T_{\max} = .200$ sec most of the minimum fit assignments satisfy $\rho > 1$.

In order to ensure a wide sampling of the solution space, many different initial topologies have been tried. About 30 different entries were generated by hand by different people: most of those entries had a number of arcs between 30 and 35. In addition to such entries, the fully connected and two highly connected initial topologies were used. For each entry 30 local minima were determined.

The results are shown in Table 6.6.1. For each entry (identified by the degree of connection or by the initials of the designer) the following values are given:

DCONT_{min} : cost of the best continuous solution (the cost is evaluated on the continuous, α fitted, curves)

TABLE 6.6.1
 COST DDISC AND TRAFFIC LOAD ρ FOR
 VARIOUS 26 NODE ARPA TOPOLOGIES

NAME	DDISC	ρ	DCONT _{min}	DCONT _{disc}	NA ₀	NA
Fully conn.	89,580	1.05	82,583	86,164	325	61
JAW	94,288	1.00	88,792	88,799	29	29
JON	94,314	1.00	84,881	86,154	33	33
MAX3	94,357	1.03	88,877	88,892	29	29
High.conn.1	95,191	1.01	82,149	82,466	41	39
KLE	95,621	1.04	89,485	90,529	31	31
TOB1	96,017	1.03	89,134	89,134	29	29
CAK	97,100	1.00	88,997	88,997	39	33
High.conn.2	97,215	1.02	82,765	82,991	41	38
MAG	97,240	1.08	83,006	83,006	34	34
BAN	98,055	1.02	90,331	91,427	33	33
DGC2	98,478	1.03	87,320	87,930	33	33
DPD	98,554	1.10	86,616	86,616	35	35
JOP2	99,783	1.03	88,405	88,764	31	31
TOM	99,992	1.06	87,513	87,574	38	35
MAG2	100,207	1.00	86,748	87,019	30	30
VCG	100,815	1.03	86,302	92,354	35	35
HIO	101,075	1.00	86,814	86,814	33	33
KRI1	101,703	1.06	84,078	84,874	31	31
BAN2	103,164	1.01	87,181	91,427	34	34
MAX2	103,371	1.00	87,306	87,728	33	32
ARI1	105,652	1.06	84,860	87,889	34	32
MAX	106,840	1.00	89,270	97,396	35	35
LAM	108,540	1.10	90,134	90,134	51	42
DUF	108,644	1.00	87,908	97,841	42	38
JOP	112,669	1.00	88,941	91,602	34	34
GAS	118,579	1.00	91,956	94,558	30	30
KLE2	122,309	1.01	90,470	90,481	29	29
DGCIP	133,251	1.03	89,591	89,591	29	29
DGC	141,396	1.10	90,247	90,431	28	28
NAM	150,968	1.10	92,991	92,991	31	30

$DCONT_{disc}$: cost of the continuous solution which generated the best discrete solution.

$DDISC$: cost of the best feasible (i.e., $\rho \geq 1$) discrete solution

ρ : relative traffic level associated with the best discrete solution.

NA'_0 : number of arcs of the initial topology

NA : number of arcs of the final topology.

The computation time for each entry was between 30 and 60 seconds on an IBM 360/91.

The results for the various entries are presented in Table 6.6.1 in order of increasing $DDISC$. The best solution ($DDISC = 89,580$, $\rho = 1.05$) was obtained from a fully connected initial topology; it has 61 arcs (see Figure 6.6.2) and uses 9.6 and 19.2 kb capacities for the medium and long lines, and 50 kb capacities for the short lines (see the distribution of the capacities with respect to link lengths in Table 6.6.2). The second best solution ($DDISC = 94,288$, $\rho = 1.00$) was obtained, on the other hand, from a low connected topology; it has 29 arcs and uses prevalently 50 and 100 kb capacities on medium and long lines, and 230 kb on very short lines (see Figure 6.6.3). The other solutions have a number of arcs variable from 28 to 42 and a cost $DDISC$ variable from 94,314 to 150,968.

From the analysis of the results, it can be noticed that most of the entries produce continuous solutions with cost $DCONT_{min}$ between 82,000 and 90,000; in particular, highly and medium connected initial

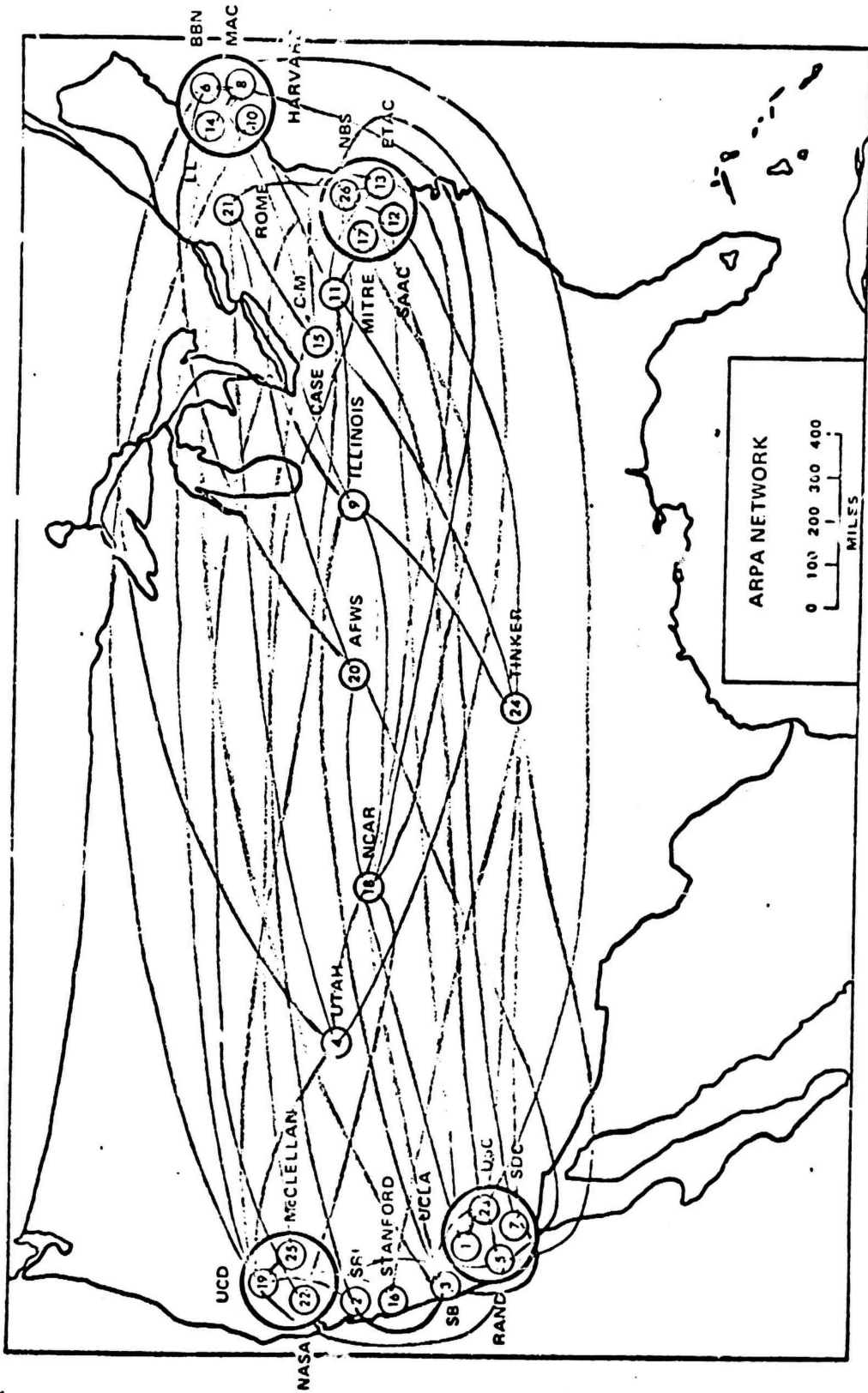

Figure 6.6.2 Best Solution: DDISC = 89,580, $\rho = 1.05$

TABLE 6.6.2
 DISTRIBUTION OF CAPACITIES VERSUS LINK LENGTHS
 FOR THE 61 ARC TOPOLOGY OF FIGURE 6.6.2

capacity [kb/sec]	Link length (miles)			
	< 100	100-500	500-1000	> 1000
9.6	0	3	8	20
19.2	1	8	2	6
50	11	2	0	0

Note: each entry represents the number of links which have the specified capacity and are within the specified length range.

topologies tend to produce better $DCONT_{min}$ than low connected topologies. Such behavior agrees with the results of Sections 6.4 and 6.5. However, it should be noticed that, for a given initial topology, the best discrete solution is not obtained from the minimum cost continuous solution (typically, $DCONT_{disc} > DCONT_{min}$); furthermore, there is almost no correlation between DDISC and $DCONT_{min}$. This fact clearly shows that the most critical step in the discrete capacities design, is the continuous-discrete transformation, rather than the determination of a good continuous solution: any effort should be directed therefore to the improvement of such transformation.

In most of the cases, the difference between DDISC and $DCONT$ can be attributed to the presence of little utilized, high cost capacities: in such cases, some clever heuristics (e.g., reduction of the load level, rerouting of some commodities, etc) could be added to the

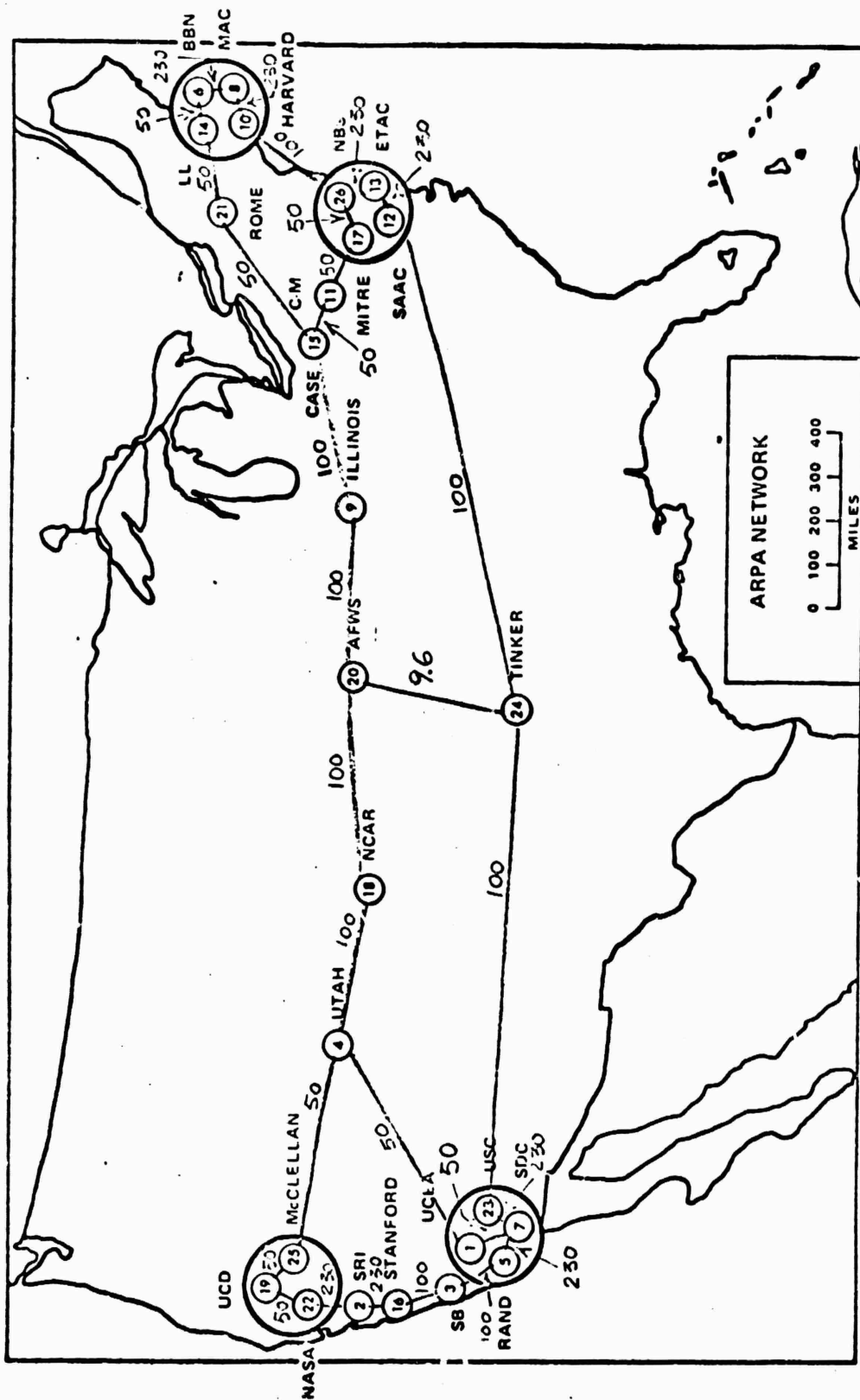

Figure 6.6.3 Second Best Solution: DDISC = 94,283, $\rho = 1.00$

minimum fit discrete capacity assignment, in order to ensure a uniform utilization of all the channels and consequently reduce the difference between continuous and discrete cost. In any case, the efficiency of a continuous-discrete transformation is very much dependent on the data (number and distribution of the discrete capacity levels, existence of a good concave approximation for the discrete costs, etc.); therefore no general considerations can be made.

It also should be noticed that the best topology is very highly connected and uses almost exclusively 9.6 and 19.2 kb capacities: this fact seems to indicate that, for the specific costs given in Table 5.8.1, better results can be obtained with very highly connected (and certainly not very intuitive!), low capacitated topologies.

Some of the results of Table 6.6.1 have been represented on a ρ versus D diagram in Figure 6.6.4a. An approximate lower bound on D , for any ρ between 1.00 and 1.10, was obtained by joining with a straight line the lower bound $D = 81,000$ for $\rho = 1.00$, and the lower bound $D = 87,000$ for $\rho = 1.10$.^{*} We notice that the excellent solution obtained from the fully connected topology ($D = 89,580$; $\rho = 1.05$) is only 6% from the lower bound; several solutions are available in the range 10-15% from the lower bound. We conjecture that the use of some clever heuristics in the continuous-discrete transformation, the exploration of a broader sample of initial topologies (including very highly connected topologies) and a more accurate^{**} evaluation of ρ

* Such lower bounds were obtained with continuous, α fitted, cost curves (see Section 6.4).

** In order to keep the computation time within reasonable limits, the CBE algorithm allows only 10 FD iterations for the maximization of ρ . A more accurate, a posteriori, evaluation of ρ is recommended for a selected set of solutions.

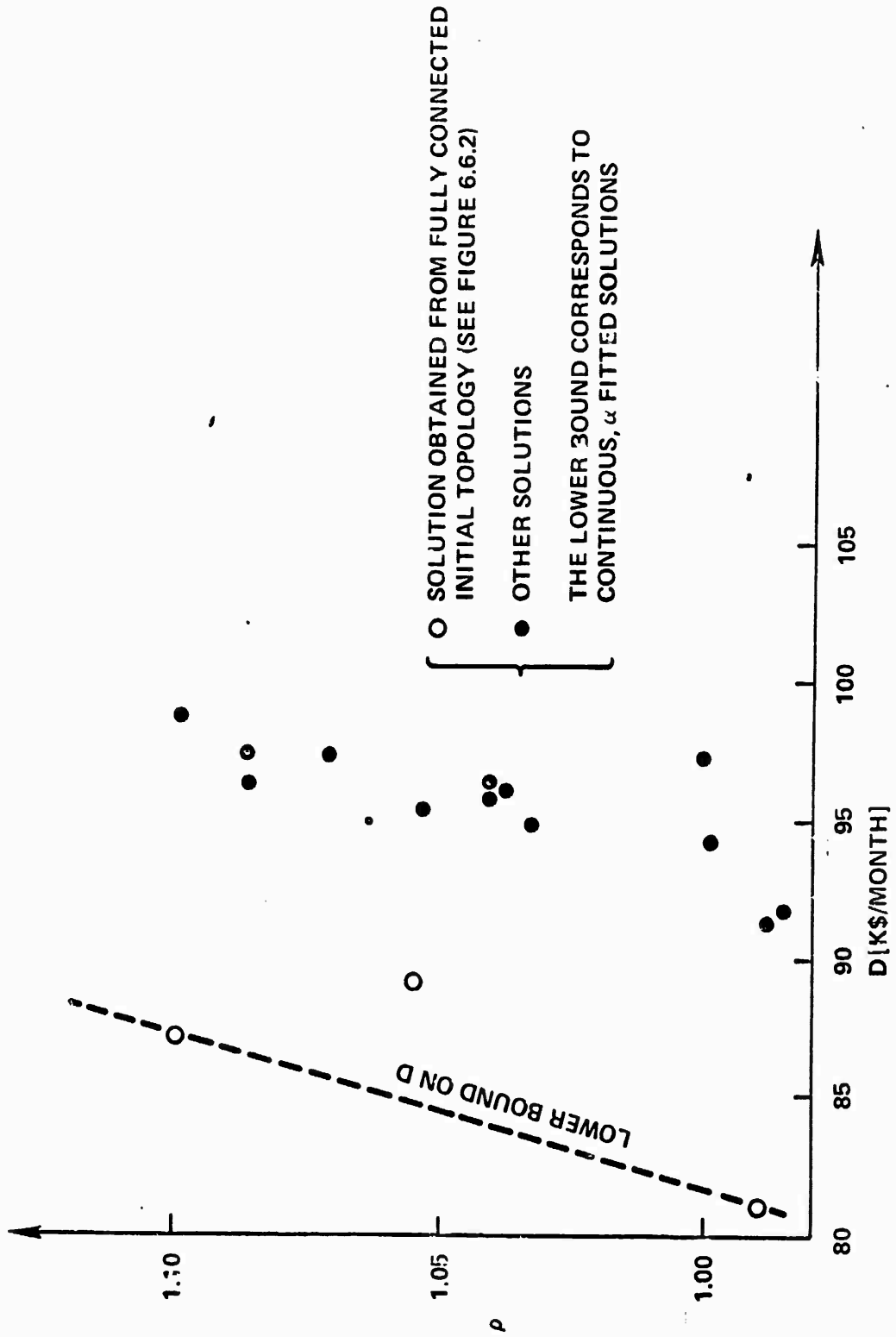

Figure 6.6.4a. Thruput ρ versus D of Some of the Discrete Solutions Shown in Table 6.6.1.

could reduce the gap and provide several solutions in the range 5-10% from the lower bound.

Lower bounds, for α fitted, and a few good discrete solutions have been computed also for a larger range of traffic level ($0.5 \leq \rho \leq 1.10$). The results are plotted in Figure 6.6.4b. Most of the solutions were obtained from the fully connected initial topology.

The above results and considerations indicate that the CBE method is a valid tool for the topological design, in those cases in which the discrete costs can be reasonably approximated by continuous, concave costs, and the discrete capacities by continuous capacities. If these conditions are not verified, the method can still be used in order to obtain interesting lower bounds [see GERL 73].

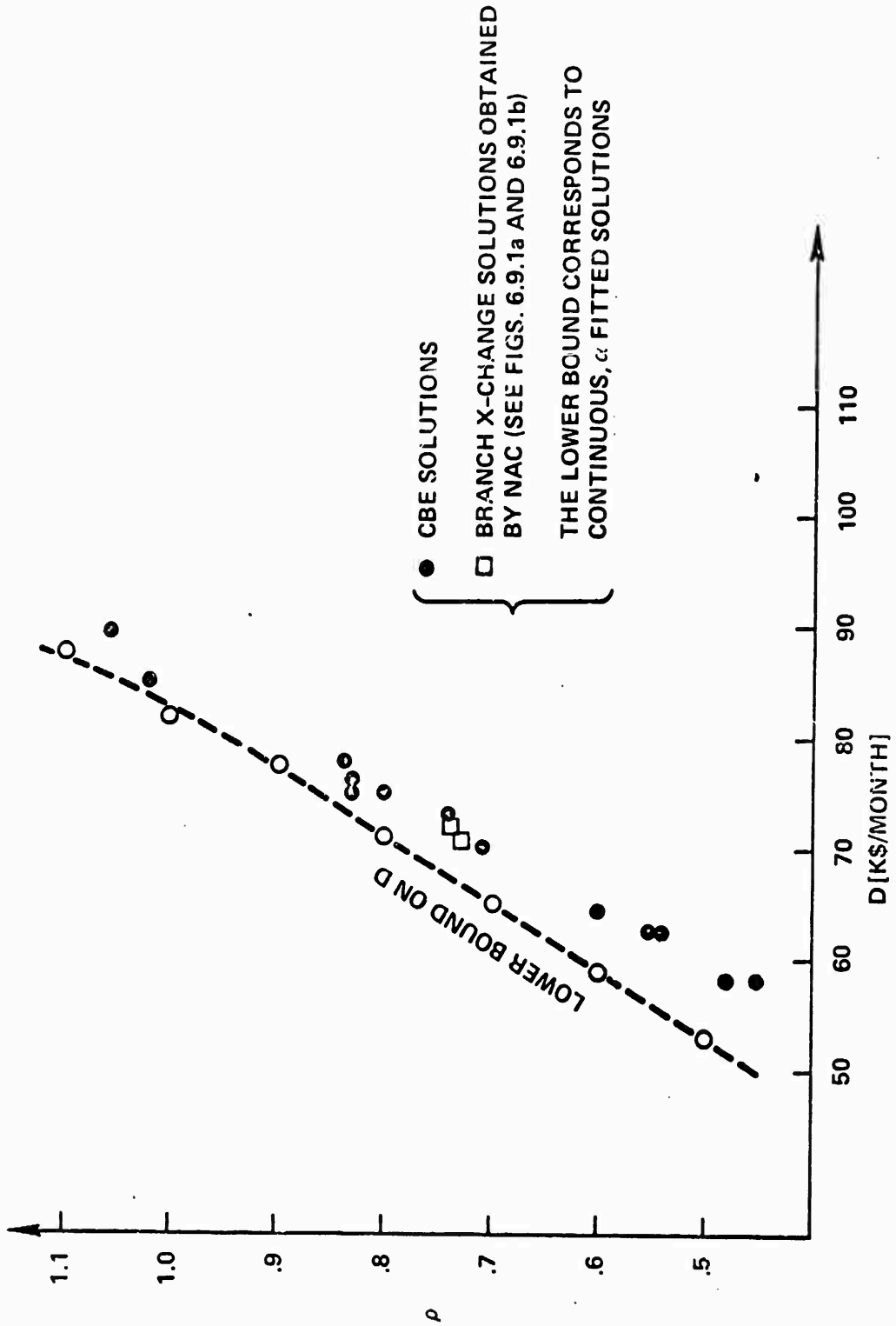

Figure 6.6.4b. Thruput ρ versus Cost D of Some Discrete Solutions Obtained in the Range $\rho = 0.5 \div 1.1$.

6.9 Conclusion

The CBE method is a topological design method applicable to multicommodity flow networks in which the objective, to be minimized, is (or can be reasonably approximated with) a continuous, concave function $D(\underline{f})$.

The method is based on the key notion of vector of equivalent lengths $\underline{\ell}$ (where $\ell_i \triangleq \partial D / \partial f_i$), which indicates the direction of steepest flow deviation (see [GERL 73]). The method finds local minima of $D(\underline{f})$; its impact on the network topology is due to the fact that for the particular nature of $D(\underline{f})^*$, the arcs with low utilization are gracefully eliminated, as the corresponding lengths become ∞ . On the other hand, proper considerations, also based on $\underline{\ell}$, permit us to insert arcs, which are likely to reduce $D(\underline{f})$.

A peculiar feature of the CBE method is, therefore, the ability to perform topological modifications by taking into account the complex interaction between cost and flow assignment (a measure of such an interaction is given, as a first approximation, by $\partial D / \partial f_i$). In a sense, during the application of the CBE method, the flow itself designs the network topology, in the attempt to find the most convenient routes.

On the other hand, branch X-change methods (see Section 6.3) perform topological modifications systematically (or on the basis of some reasonable considerations), with little or no attention to the cost-flow interaction.

* For an efficient topological reduction we also require that:

$$\lim_{f_i \rightarrow 0} \frac{\partial D(\underline{f})}{\partial f_i} = \infty, \forall i$$

Clearly, the CBE method cannot be applied to those cases in which there is no meaningful notion of marginal cost (e.g., only one discrete capacity level; pure set up costs): in such cases, branch X-change methods are the only alternative. Also, branch X-change methods can be conveniently applied to problems where the evaluation of flow and cost after each topological transformation is straightforward (e.g., tree structures [FRAN 71A]).

In this chapter we discussed various applications and pointed out cases in which CBE performs very well (power law cost curves with $\alpha \approx 1$); cases in which CBE gives reasonable results ($\alpha \approx 0.6$; discrete problems with a sufficient number of capacity levels); cases for which the CBE method is not adequate (pure set up costs; $\alpha \rightarrow 0$; only one discrete capacity level).

An interesting comparison between CBE and branch X-change approach is possible if we analyze the method proposed by Frank et al. [FRAN 70] for the design of minimum cost computer network topologies. The method operates topological transformations with branch X-change techniques. After each transformation, the flow is assigned to shortest routes, computed with uniform link lengths $l_i = 1, \forall i$. In order to provide a more compact representation of such a method, let us consider a fully connected topology and let us label the arcs in such a topology from 1 to NA. We can now associate with a specific topology a vector of equivalent lengths \underline{l} , such that $l_i = 1$, if arc i belongs to the topology, and $l_i = \infty$ otherwise; for example:

$$\underline{l} = (1, 1, \infty, \infty, \dots, 1, \infty, \dots, 1)$$

A topological transformation can be, then, represented as a change of

some entries of $\underline{\ell}$ from 1 to ∞ and vice versa. Similarly, flows are routed on shortest paths computed according to $\underline{\ell}$.

If we now apply the CBE method to the same problem, we have an equivalent lengths vector $\underline{\ell}$ of the following form:

$$\underline{\ell} = (\ell_1, \ell_2, \infty, \infty, \dots, \ell_k, \infty, \dots, \ell_{NA})$$

The vector $\underline{\ell}$ now depends, not only on the topology, but also on cost and flow characteristics of the arcs. As for the topological transformations, arc i is automatically eliminated when ℓ_i becomes ∞ ; on the other hand, if $\ell_i = \infty$ and cost-flow considerations indicate that the insertion of arc i would reduce $D(\underline{f})$, length ℓ_i is set to a proper value $< \infty$.

The first method can be therefore considered as an extreme simplification of the CBE method, in which $\underline{\ell}$ carries no information about marginal costs. The method is certainly a good heuristic approach to problems that have no notion of marginal cost; in particular, the method was applied by NAC [NAC 71B] to the design of minimum cost ARPA topologies, in which only 50 kb capacities were allowed, and produced very satisfactory results. Two solutions obtained by NAC for the familiar 26 nodes problem,^{*} are shown in Figures 6.9.1a and 6.9.1b and are compared to the CBE discrete solutions in the ρ vs. D plot of Figure 6.6.4h.

^{*}The costs shown in Table 5.8.1 were used.

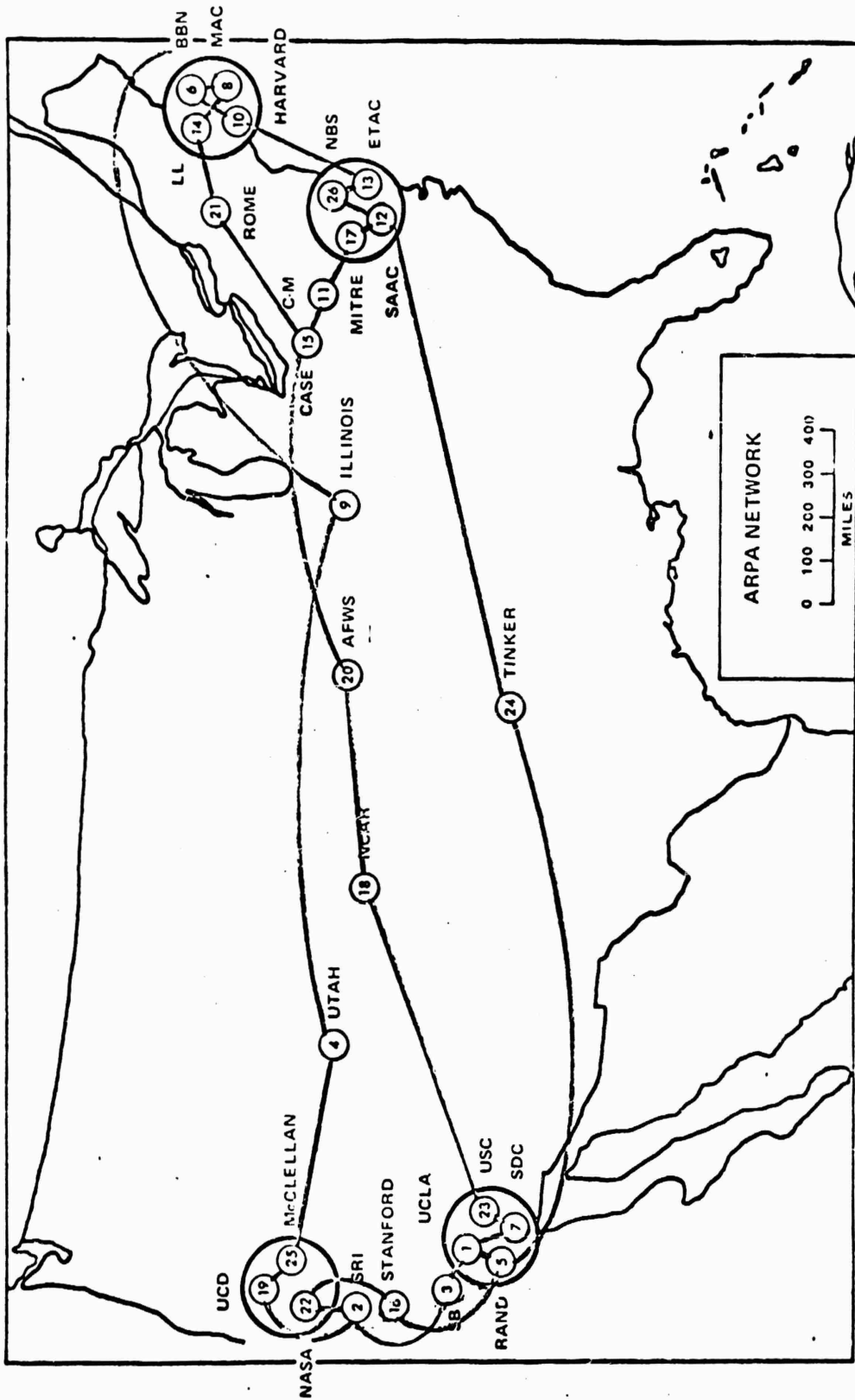

All capacities 50 kb
 $D = 70,512$ [kR/month]
 $r = .75$ [kb/sec x node pair]

Figure 6.9.1a 26 Node, 29 Arc ARPA Topology, Designed by NAC

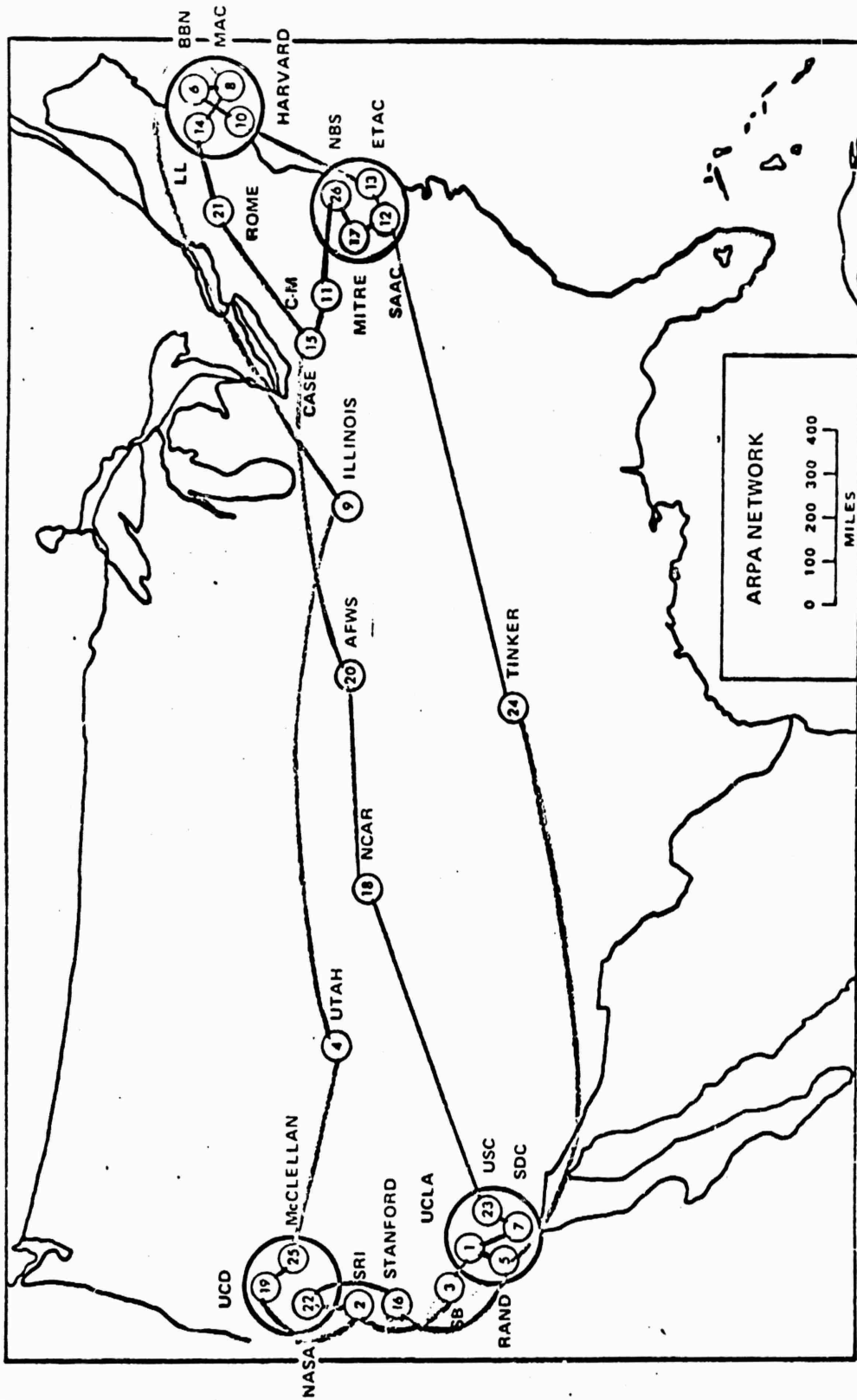

All capacities 50 kb
 D = 72,538 [k\$/month]
 r = .74 [kb/sec x node pair]

Figure 6.9.1b 26 Node, 30 Arc ARPANET Topology, Designed by NAC

BIBLIOGRAPHY

- ABRA 70 Abramson, N., "The ALOHA System--Another Alternative for Computer Communications," AFIPS Conference Proceedings, 37:281-285, FJCC, Las Vegas, Nev., 1970.
- ASS 72 "ASS (ARPA Net Satellite System) Notes," Network Information Center, Stanford Research Institute, Menlo Park, Calif., 1972.
- BANS 72 Bansal, P. P., Optimal Network Flow Capacity Expansion Under Concave Costs, Ph.D. Dissertation, School of Engineering and Applied Science, Computer Science Dept., University of California, Los Angeles, June 1972.
- BASK 72 Baskett, F., and R. Muntz, "Queueing Network Models with Different Classes of Customers," IEEE Computer Conference Proceedings, pp. 205-209, San Francisco, Calif., September 1972.
- BERG 62 Berge, C., The Theory of Graphs, Methuen and Co., London, 1962.
- BURK 56 Burke, P. J., "The Output of a Queueing System," Operations Research, 4:699-704, 1956.
- CANT 72 Cantor, D., and M. Gerla, "The Optimal Routing of Messages in a Computer Network via Mathematical Programming," IEEE Computer Conference Proceedings, pp. 167-170, San Francisco, Calif., September 1972.
- CARR 70 Carr, S., S. Crocker, and V. Cerf, "HOST-HOST Communication Protocol in the ARPA Network," AFIPS Conference Proceedings, 36:589-597, SJCC, Atlantic City, N.J., 1970.
- CHAN 72A Chandy, K. M., "The Analysis and Solutions for General Queueing Networks," Proceedings of the Sixth Annual Princeton Conference on Information Sciences and Systems, Princeton University, March 1972.
- CHAN 72B Chandy, K. M., and R. A. Russel, "The Design of Multipoint Linkages in a Teleprocessing Tree Network," IEEE Transactions on Computers, C-21:1060-1066.
- CHAR 61 Charles, A., and W. W. Cooper, "Multicopy Traffic Network Models," Proceedings of the Symposium on the Theory of Traffic Flow, pp. 231-240, Detroit, Mich., 1961.

- COLE 71 Cole, G. C., Computer Network Measurements: Techniques and Experiments, School of Engineering and Applied Science, University of California, Los Angeles, UCLA-ENG-7165, 1971.
- CROC 72 Crocker, S., J. Haefner, R. Metcalfe, and J. Postel, "Function-Oriented Protocols for the ARPA Computer Network," AFIPS Conference Proceedings, 40:271-279, SJCC, Atlantic City, N.J., 1972.
- DAFE 69 Dafermos, S. C., and F. T. Sparrow, "The Traffic Assignment Problem for a General Network," Journal of Research of the National Bureau of Standards--B, Vol. 73B, No. 2, April 1969.
- DANT 63 Dantzig, G. B., Linear Programming and Extensions, Princeton University Press, Princeton, N.J., 1963.
- DAVI 68 Davies, D. W., "The Principals of a Data Communication Network for Computers and Remote Peripherals," Proceedings of the IFIP Congress, pp. D11-D15, Edinburg, Scotland, 1968.
- ESAU 66 Esau, L. R., and K. C. Williams, "A Method for Approximating the Optimal Network," IBM Systems Journal, 5:142-147, 1966.
- ESTR 67 Estrin, G., and L. Kleinrock, "Measures, Models and Measurements for Time-Shared Computer Utilities," Proceedings of the 22nd National Conference, ACM, pp. 85-96, Washington, D.C., 1967.
- EVER 63 Everett, H. III, "Generalized Lagrange Multipliers Method for Solving Problems of Optimal Allocation of Resources," Operations Research, 11:399-418, 1963.
- FARB 72 Farber, D. J., "Networks: An Introduction," Datamation, pp. 36-39, April 1972.
- FLOR 71 Florian, M., and P. Robillard, "An Implicit Enumeration Algorithm for the Concave Cost Network Flow Problem," Management Science, 18:184-193, November 1971.
- FLOY 62 Floyd, R. W., "Algorithm 97, Shortest Path," Communications of the ACM, 5(6):345, June 1962.
- FORD 58 Ford, L. K., and D. R. Fulkerson, "A Suggested Computation for Maximal Multicommodity Network Flows," Management Science, 5:97-101, 1958.
- FORD 62 Ford, L. R. Jr., and D. R. Fulkerson, Flows in Networks, Princeton University Press, Princeton, N.J., 1962.
- FOX 66 Fox, B., "Discrete Optimization via Marginal Analysis," Management Science, 13:210-216, November 1966.

- FRAN 69 Frank, H., B. Rothfarb, D. Kleitman, and K. Steiglitz, "Design of Economical Offshore Natural Gas Pipeline Networks," Office of Emergency Preparedness, Report R-1, Washington, D.C., January 1969.
- FRAN 70 Frank, H., I. T. Frisch, and W. Chou, "Topological Considerations in the Design of the ARPA Computer Network," AFIPS Conference Proceedings, 36:581-587, SJCC, Atlantic City, N.J., 1970.
- FRAN 71A Frank, H., I. T. Frisch, W. Chou, and R. Van Slyke, "Optimal Design of Centralized Computer Networks," Networks, 1:43-57, 1971.
- FRAN 71B Frank, H., and W. Chou, "Routing in Computer Networks," Networks, 1:99-112, 1971.
- FRAN 72 Frank, H., R. E. Kahn, and L. Kleinrock, "Computer-Communication Network Design--Experience with Theory and Practice," AFIPS Conference Proceedings, 40:255-270, SJCC, Atlantic City, N.J., 1972.
- FRAT 72 Fratta, L., and M. Gerla, "The Synthesis of Computer Networks: Properties of the Optimum Solution," ACM-International Computing Symposium, Venice, Italy, April 1972.
- FRAT 73 Fratta, L., M. Gerla, and L. Kleinrock, "The Flow Deviation Method: An Approach to Store-and-Forward Communication Network Design," to appear in Networks.
- FRIS 67 Frisch, I. T., "Analysis of the Vulnerability of Communication Nets," Proceedings of the First Annual Princeton Conference on Systems Science, pp. 188-192, Princeton, N.J., 1967.
- FUCH 70 Fuchs, E., and P. E. Jackson, "Estimates of Distributions of Random Variables for Certain Computer Communications Traffic Models," Communications of the ACM, 13(12):752-757, December 1970.
- FULT 71 Fultz, G. L., and L. Kleinrock, "Adaptive Routing Techniques for Store-and-Forward Computer-Communication Networks," Proceedings of the International Conference on Communications, pp. 39-1 to 39-8, Montreal, Canada, 1971.
- FULT 72 Fultz, G. L., Adaptive Routing Techniques for Message Switching Computer-Communication Networks, School of Engineering and Applied Science, University of California, Los Angeles, UCLA-ENG-7252, July 1972.

- GAVE 68 Gaver, D. P., "Diffusion Approximations and Models for Certain Congestion Problems," Journal of Applied Probability, 5:607-623, 1968.
- GERL 73 Gerla, M., The Design of Store-and-Forward (S/F) Networks for Computer Communications, Ph.D. Dissertation, Computer Science Department, University of California, Los Angeles, 1973.
- HADL 64 Hadley, G., Non-Linear and Dynamic Programming, Addison-Wesley, Reading, Mass., 1964.
- HEAR 70 Heart, F. E., R. E. Kahn, S. M. Ornstein, W. R. Crowther, and D. C. Walden, "The Interface Message Process for the ARPA Computer Network," AFIPS Conference Proceedings, 36:551-567, SJCC, Atlantic City, N.J., 1970.
- HU 68 Hu, T. C., "A Decomposition Algorithm for Shortest Paths in a Network," Operations Research, 16:91-102, 1968.
- HU 69 Hu, T. C., Integer Programming and Network Flows, Addison-Wesley, Reading, Mass., 1969.
- JACK 57 Jackson, J. R., "Networks of Waiting Lines," Operations Research, 5:518-521, 1957.
- KAHN 71 Kahn, R. E., and W. R. Crowther, "A Study of the ARPA Computer Network Design and Performance," Bolt, Beranek and Newman, Inc. Report No. 2161, August 1971.
- KLEI 64 Kleinrock, L., Communication Nets: Stochastic Message Flow and Delay, McGraw-Hill, New York, 1964.
- KLEI 69 Kleinrock, L., "Models for Computer Networks," Proceedings of the International Communications Conference, pp. 21-9 to 21-16, Boulder, Colo., June 1969.
- KLEI 70 Kleinrock, L., "Analytic and Simulation Methods in Computer Network Design," AFIPS Conference Proceedings, 36:569-579, SJCC, Atlantic City, N.J., 1970.
- KLEI 73 Kleinrock, L., Queueing Systems: Theory and Applications, to be published by Wiley Interscience, New York, 1973.
- KLET 69 Kleitman, D. J., "Methods for Investigating Connectivity of Large Graphs," IEEE Transactions on Circuit Theory, pp. 232-233, May 1969.
- LIN 65 Lin, S., "Computer Solutions of the Traveling Salesman Problem," The Bell System Technical Journal, pp. 2245-2269, December 1965.

- MANG 69 Mangasarian, O. L., Non-Linear Programming, McGraw-Hill, New York, 1969.
- MART 67 Martin, J., Design of Real-Time Computer Systems, Prentice-Hall, Englewood Cliffs, N.J., 1967.
- MEIS 72 Meister, B., H. R. Mueller, and H. R. Rudin, Jr., "On the Optimization of Message-Switching Networks," IEEE Transactions on Communications, COM-20(1):8-14, February 1972.
- MUNT 72A Muntz, R., "Poisson Departure Processes and Queueing Networks," IBM Thomas J. Watson Research Center, IBM Report RC 4145, September 1972.
- MUNT 72B Muntz, R., and F. Baskett, "Open, Closed and Mixed Networks of Queues with Different Classes of Customers," submitted to JACM, 1972.
- NAC 70 "Analysis and Optimization of Store-and-Forward Computer Networks," N.A.C. Second Semiannual Technical Report for the Project, Defense Documentation Center, December 1970.
- NAC 71 "Analysis and Optimization of Store-and-Forward Computer Networks," N.A.C. Fourth Semiannual Technical Report for the Project, Defense Documentation Center, December 1971.
- NEWE 71 Newell, G. F., Applications of Queueing Theory, Chapman and Hall, Ltd., London, 1971, Chap. 6.
- PIER 71 Pierce, J. R., "Network for Block Switching of Data," IEEE Convention Record, New York, N.Y., March 1971.
- PORT 71 Port, E., and F. Closs, "Comparison of Switched Data Networks on the Basis of Waiting Times," IBM Zurich, Report RZ405, January 1971.
- ROBE 67 Roberts, L. G., "Multiple Computer Networks and Inter-Computer Communications," ACM Symposium on Operating Systems Principles, Gatlinburg, Tenn., October 1967.
- ROBE 70 Roberts, L. G., and B. D. Wessler, "Computer Network Development to Achieve Resource Sharing," AFIPS Conference Proceedings, 36:543-599, SJCC, Atlantic City, N.J., 1970.
- ROBE 72 Roberts, L., "Extensions of Packet Communication Technology to a Hand-Held Personal Terminal," AFIPS Conference Proceedings, 40:295-298, SJCC, Atlantic City, N.J., 1972.
- SEN 72 Sen, S., "A Multi-Commodity Concave Cost Minimization Problem for Communication Networks," University of California, Berkeley, Operations Research Center, ORC 72-5, February 1972.

- SLYK 71 Van Slyke, R., and H. Frank, "Network Reliability Analysis: Part I," Networks, 1:279-290, 1971.
- SOLA 71 Soland, R. M., "An Algorithm for Separable Nonconvex Programming Problems II: Nonconvex Constraints," Management Science, 17:759-773, 1971.
- STEI 69 Steiglitz, K., P. Weiner, and D. J. Kleitman, "The Design of Minimum Cost Survivable Networks," Transactions on Circuit Theory, pp. 455-460, November 1969.
- TOML 66 Tomlin, J. A., "Minimum Cost Multi-Commodity Network Flows," Operations Research, 14:45-47, January 1966.
- WARD 52 Wardrop, J. G., "Some Theoretical Aspects of Road Traffic Research," Proceedings of the Institution of Civil Engineers, Part II, Vol. I, pp. 325-379, London, England, January 1952.
- WHIT 70 Whitney, V. K. M., "A Study of Optimal File Assignment and Communication Network Configuration in Remote-Access Computer Message Processing and Communication's Systems," University of Michigan SEL Technical Report No. 48, September 1970.
- WHIT 72A Whitney, V. K. M., "Lagrangian Optimization of Stochastic Communication Systems Models," MRI Symposium on Computer Communication Networks, Brooklyn, N.Y., April 1972.
- WHIT 72B Whitney, V. K. M., "Comparison of Network Topology Optimization Algorithms," ICCC Conference Proceedings, pp. 332-342, Washington, D.C., October 1972.
- YAGE 71 Yaged, B. Jr., "Minimum Cost Routing for Static Network Models," Networks, 1:139-172, 1971.
- ZANG 68 Zangwill, W. I., "Minimum Concave Cost Flows in Certain Networks," Management Science, 14:429-450, March 1968.
- ZEIG 71 Zeigler, J. F., Nodal Blocking in Large Networks, School of Engineering and Applied Science, University of California Los Angeles, UCLA-ENG-7167, 1971.