

AD-756 855

TEST INSTRUMENTATION SUBSYSTEM
PERFORMANCE SPECIFICATION, MODEL
NUMBER DYNA SOAR

Boeing Company
Seattle, Washington

13 December 1960

DISTRIBUTED BY:

NTIS

National Technical Information Service
U. S. DEPARTMENT OF COMMERCE
5285 Port Royal Road, Springfield Va. 22151

BOEING AIRPLANE COMPANY
SEATTLE 24, WASHINGTON

AD 756855



DOCUMENT NO. D2-7868

UNCLASSIFIED TITLE TEST INSTRUMENTATION SUBSYSTEM
PERFORMANCE SPECIFICATION

MODEL NO. DYNA SCAR CONTRACT NO. AF33(600)-41517

ISSUE NO. 284 ISSUED TO L.P. Snow

CLASSIFIED TITLE _____
(STATE CLASSIFICATION)

76115 2-5636 00182
WORK ORDER NO. UNIT NO. ITEM NO.

SPECIAL LIMITATIONS ON ASTIA DISTRIBUTION

Reproduced by
**NATIONAL TECHNICAL
INFORMATION SERVICE**
U S Department of Commerce
Springfield VA 22151

Details of illustrations in
this document may be better
studied on microfiche.

DISTRIBUTION STATEMENT A
Approved for public release;
Distribution Unlimited

DDC
RECEIVED
MAR 13 1973
RECEIVED
B

PREPARED BY Data Systems Engineering Group

SUPERVISED BY [Signature] 12/2/66
G. M. Taylor

APPROVED BY [Signature] 1/12/67
L. C. Perkins

CLASS. & DISTR. [Signature]
APPROVED BY [Signature] 1/13/67
(DATE)

NO. OF PAGES 81 (EXCLUDING TITLE AND REVISION AND ADDITION PAGES.) **R**

Revised: 5-22-62

"Approved for public release; distribution unlimited"

DOCUMENT TITLE PAGE

82 R 8-70

CHANGE RECORD

				REV							
REV	REVISED	ADDED	DELETED	REV	REVISED	ADDED	DELETED	REV	REVISED	ADDED	DELETED
	Complete	12-12-60									
	Former title was: 'Dyna-Soar Telemetry Subsystem Performance Specification'.										
	Complete Revision	5-22-62									
	Active pages: a, b 1, 1a										
	(Actual Release - 5/31/62) 2-80										
5-22-62						BOEING AIRPLANE COMPANY				D2-786B	
						<i>I</i>				P NO. a	

REVISIONS

This is a complete revision to reflect current Test Instrumentation Subsystem design and performance per the Titan III configuration.

5-22-62

Approved

L. O. Carpenter
L. O. Carpenter

5/29/62

REVISED 5-22-62

U3 4288 2000

BOEING

VOL

NO D2-7868

SEC

PAGE b

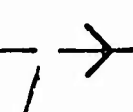

ACKNOWLEDGMENT PAGE

All personnel of the Test Data Systems Unit contributed in the preparation of this document. The major contributors were:

H. H. West

W. A. Swenning

E. W. Goodwin

J. F. Dunn

A. S. Izydore

B. A. Rayfield

L. T. Hunter



TABLE OF CONTENTS

<u>GENERAL SECTION</u>	<u>PAGE</u>
1.0 SCOPE	6
2.0 APPLICABLE DOCUMENTS	7
3.0 PERFORMANCE AND DESIGN REQUIREMENTS	9
4.0 TESTING REQUIREMENTS	13
5.0 NOTES AND SUPPLEMENTAL REQUIREMENTS	14
 <u>TAB "A" - GLIDER INSTRUMENTATION SUBSYSTEM</u>	
1.0 SCOPE	16
2.0 APPLICABLE DOCUMENTS	17
3.0 GENERAL PERFORMANCE AND DESIGN REQUIREMENTS	18
4.0 SPECIFIC PERFORMANCE AND DESIGN REQUIREMENTS	26
5.0 TESTING REQUIREMENTS	35
6.0 NOTES AND SUPPLEMENTAL REQUIREMENTS	36
 <u>TAB "B" - BOOSTER INSTRUMENTATION SUBSYSTEM</u>	
	38
 <u>TAB "C" - B-52 CARRIER INSTRUMENTATION SUBSYSTEM</u>	
	40
 <u>TAB "D" - GROUND DATA RECOVERY SUBSYSTEM</u>	
1.0 SCOPE	42
2.0 APPLICABLE DOCUMENTS	43
3.0 FACILITIES AND LOCATION	44
4.0 GENERAL PERFORMANCE AND DESIGN REQUIREMENTS	52
5.0 SPECIFIC PERFORMANCE AND DESIGN REQUIREMENTS	54
6.0 TESTING REQUIREMENTS	60
7.0 NOTES AND SUPPLEMENTAL REQUIREMENTS	61



TABLE OF CONTENTS

<u>TAB "E" - DATA PROCESSING SUBSYSTEM.</u>	<u>PAGE</u>
1.0 SCOPE	63
2.0 APPLICABLE DOCUMENTS	64
3.0 GENERAL PERFORMANCE AND DESIGN REQUIREMENTS	65
4.0 SPECIFIC PERFORMANCE AND DESIGN REQUIREMENTS	66
5.0 TESTING REQUIREMENTS	68
6.0 NOTES AND SUPPLEMENTAL REQUIREMENTS	69
 <u>TAB "F" - GROUND CHECK-OUT AND SUPPORT SUBSYSTEM</u>	
1.0 SCOPE	71
2.0 IN-PLANT TESTS	72
3.0 OUT-PLANT TESTS	77
4.0 IN-PLANT CALIBRATIONS	78
5.0 OUT-PLANT CALIBRATIONS	80



SECTION I
GENERAL SECTION

071-1000 (was BAC 1544-LR3)

5-22-62

BOEING

NO. D2-7868

PAGE 5



1.0

SCOPE

This specification establishes the performance, design, development, and testing requirements for the Dyna-Soar Test Instrumentation Subsystem (TIS).

1.1

TAB SYSTEM

The main section of this specification describes general requirements which are applicable to all components of the Test Instrumentation Subsystem (including all secondary subsystems). This specification is further arranged to inter-relate the secondary subsystems of the TIS and to describe additional requirements pertinent to each such subsystem. Separate TAB designations are assigned to the secondary subsystem as follows:

- TAB A: Glider Instrumentation Subsystem
- TAB B: Booster Instrumentation Subsystem
- TAB C: B-52 Carrier Instrumentation Subsystem
- TAB D: Ground Data Recovery Subsystem
- TAB E: Data Processing Subsystem
- TAB F: Ground Check-Out and Support Subsystem



2.0

APPLICABLE DOCUMENTS

The following Government documents and other publications constitute a part of this specification to the extent defined herein. Where conflicting requirements exist, the requirements of this specification shall govern.

2.1

GOVERNMENT DOCUMENTS

AF Bulletin 67B	Current List of Strategic and Critical Materials
MIL-STD-143	Specifications and Standards, Order of Precedence for the Selection of, Dated 15 June 1960
IRIG Document 104-60	IRIG Standard Time Formats
MIL-D-70327	Drawings, Engineering and Associated Lists
MIL-E-4158B	Electronic Equipment, Ground, General Requirements for
MIL-E-8189B	Electronic Equipment, Guided Missiles, General Specification for
ASNR 61-1	Human Factors Data for Manned Aircraft Weapon Systems
MIL-I-26600	Interference Control Requirements, Aeronautical Equipment
MIL-H-26512	Maintainability Requirements for Weapon, Support, and Command and Control Systems and Equipment
MIL-STD-130A	Identification Marking of U.S. Military Property
ASD Technical Report 61-381	Guide to Design of Mechanical Equipment for Maintainability, Dated 11 August 1961



2.2

NON-GOVERNMENT DOCUMENTS

D2-7342	Dyna-Soar Master Data Measurement List
D2-7391	Specification, Characteristics of Glider Electric Power and General Requirements for Load Equipment
D2-7417-1	Specification for Dyna-Soar Communications and Tracking Subsystem
D2-7481	Electronic Packaging Requirements, Contract Procured Flight Equipment
D2-80396	General Requirements for Dyna-Soar Source Control Drawings and Procurement Specifications
Dwg No. 25-80231	Test Instrumentation Subsystem, Airborne, Envelope of
Dwg No. 25-80670	Signal Conditioning - Test Instrumentation Subsystem; Envelope of
D2-80108	Test Instrumentation Transducers Installation Handbook

5-22-62



3.0

PERFORMANCE AND DESIGN REQUIREMENTS

3.1

SUBSYSTEM DESCRIPTION

The function of the Test Instrumentation Subsystem (TIS) is to acquire test data concerning the operation of the various glider subsystems, the performance of the air vehicle, and the condition of the pilot during the Air Launch and Ground Launch phases of the Dyna-Soar Test Program. The TIS consists of the following five major subsystems which are treated in detail in the TAB sections of this specification.

3.1.1

Glider Instrumentation Subsystem

The Glider Instrumentation Subsystem consists of equipment to sense, process, store, and transmit test data and pilot voice. Frequency Modulation (FM) and Pulse Code Modulation (PCM) techniques will be employed to gather the continuous data and sampled data, respectively. All collected data will be recorded on board as the primary means of data acquisition. The PCM data and selected FM data will be routed to the Communications and Tracking Subsystem (CTS) for transmittal to the Ground Data Recovery Subsystem. The CTS requirements are specified in Boeing Document D2-7417-1.

Wide-Band and Narrow-Band telemetered data will be available during specific periods of flight. Band-switching will be accomplished in accordance with the Data Acquisition requirements of Paragraph 3.2.3.

3.1.2

Ground Data Recovery Subsystem

The Ground Data Recovery Subsystem utilizes the ground elements of the Communications and Tracking Subsystem to receive the glider telemetered data. The CTS will down-convert the glider signal to a frequency suitable for input into a standard VHF telemetry receiver (215-260 Mc range) or, if required, into the Predetection Recording System. The post-detected output of the Predetection Recording system or VHF receiver is delivered to the PCM and FM elements of the Ground Data Recovery Subsystem, which are capable of converting their respective signals into time-correlated outputs suitable for display and recording.

3.1.3

Data Processing Subsystem

The Data Processing Subsystem utilizes the elements of Paragraph 3.1.2 and Computer Input Preparation Equipment to process the telemetered and recorded data into quick-look and final format. The PCM data and digital Inertial Guidance data will be prepared for input into a general purpose digital computer. The FM data will be converted to a form suitable for recording on standard IRIG, 14 track, magnetic tape.



3.1.4

B-52 Carrier Instrumentation Subsystem

Real-time displays of the pitch, roll and yaw moments of the glider/pylon attach points and of the glider position and attitude during pre-launch and launch will be available at the B-52 Test Engineer's Station during the Air Launch Test Program. Specific performance requirements have been deleted from this specification and are now a part of the B-52 Modification Program.

3.1.5

Ground Check-Out and Support Subsystem

An In-Plant and Out-Plant test and calibration program is required to provide the Test Instrumentation Subsystem with the highest degree of accuracy and reliability consistent with the design mission of Dyna-Soar. The major components of the subsystem will be located at Seattle, AFFTC, and AFMTC. The PCM test data will be programmed for computer processing.

3.2

GENERAL PERFORMANCE REQUIREMENTS

3.2.1

PCM System Accuracy

The accuracy shall be such as to satisfy the end-to-end channel accuracy requirements as specified in Document D2-7342, "Master Data Measurements List." To minimize the Transducer and Signal Conditioner development effort there shall be no more than 4.5% probability of amplitude errors, as measured from the input to the airborne PCM Conversion Set to the final data form, exceeding 0.6% of full scale, and 0.1% probability of errors exceeding 1.0% of full scale. These accuracy requirements are based on random ten-minute operating periods.

3.2.2

FM System Accuracy

Using the same criteria as for the PCM system, there shall be no more than 1.0% probability of exceeding amplitude errors of $\pm 14.5\%$ at $B = 1$, $\pm 5.8\%$ at $B = 2$, and $\pm 2.0\%$ at $B = 5$. Also, there shall be no more than 0.1% probability of exceeding $\pm 18.5\%$ at $B = 1$, $\pm 7.4\%$ at $B = 2$, and $\pm 2.6\%$ at $B = 5$. ($B = \text{Deviation Ratio}$).

3.2.3

Data Acquisition

The A/B Data Tape Recorder is the primary means of data acquisition. As such, it shall be capable of storing all of the collected data for any glider configuration as specified by D2-7342. Telemetry requirements are established in accordance with the following criteria:

- a) PCM data, Inertial Guidance data, and air-to-ground communications through the flight.
- b) Flutter data, as defined by D2-7342, plus PCM, Voice & IG, up to Mach 10. Vehicle velocity at which information bandwidth switching will occur has not yet been determined.



3.2.4

Reliability

The Test Instrumentation Subsystem shall have a reliability commensurate with the required reliability for the design mission of the Dyna-Soar Program. The reliability for each major subsystem is specified in the applicable TAB Section.

3.2.5

Environment

The environmental requirements are specified in each of the applicable TAB Sections.

3.2.6

Life

The airborne equipment shall be designed for a minimum use period, by Boeing, of 400 hours without "major repair", as defined in Paragraph 5.4.

3.3

GENERAL DESIGN REQUIREMENTS

3.3.1

Electric Power

The power requirements are specified in each of the applicable TAB Sections.

3.3.2

Electronic Equipment Installation

Equipment installation requirements are specified in each of the applicable TAB Sections.

3.3.3

Self-Test Capabilities

In order to achieve the accuracy specified in Paragraph 3.2.1, the airborne portion of the PCM System shall be provided with an in-flight error-detection system. These detected errors will be used as references by data processing for data correction purposes. Specific channels are included in D2-7342.

3.3.4

Standardization

The equipment shall be designed to achieve the highest degree of standardization possible without restricting design development. Fabrication practices, materials, processes, finishes, and parts shall comply with ANA Bulletin 143d which selects standards in the following order of precedence; MIL, AN, NAS, Commercial, and WCS.



3.3.5

Interchangeability

All replaceable parts or assemblies having the same part number shall be directly and completely inter-changeable with each other with respect to installation and performance. Replacement of interchangeable parts will not require the replacement or mechanical realignment of adjacent assemblies. Changes in part numbers shall be governed by the drawing requirements of MIL-D-70327. Interchangeability requirements are not applicable to detail parts of permanent assemblies, such as welded assemblies or matched detailed parts.

3.3.6

Human Factors

The Test Instrumentation Subsystem shall be designed in conformance with the principles of human factors engineering as outlined in the technical documents which form a part of Specification ASNR 61-1. The objective shall be to achieve an optimum balance between human operator performance capabilities and subsystem performance. The human engineering effort shall not be limited to individual system operation, but shall include an over-all integration based on operator analysis, time-line and time-motion studies, mission profiles, and evaluation of man-machine functions.

3.3.7

Maintainability

The TIS shall be designed in accordance with the requirements of MIL-M-26512A. Where practical, criteria of ASD Technical Report 61-381 shall apply.

3.3.8

Safety

The TIS shall be designed to maintain high standards of safety. In particular, any equipment installed in the glider pilot's compartment shall not contaminate the compartment atmosphere and shall be explosion-proof.

3.3.9

Radio Interference Suppression

The equipment shall meet the requirements of MIL-I-26600.

3.3.10

Product Identification

The equipment shall be marked for identification in accordance with MIL-STD-130A.

3.3.11

Critical Materials

The use of critical materials, as contained in AF Bulletin 67B, shall be avoided.

3.3.12

Ground Support and Check-out Equipment

The requirements for these items are specified in TAB "F".

4.0

TESTING REQUIREMENTS

Laboratory test program shall be established to:

- a) Predict performance requirements.
- b) Prove feasibility of approach for critical state-of-the-art areas.
- c) Verify that performance and life requirements of the subsystem and its components satisfy design and performance requirements.
- d) Assure that the manufacturing techniques employed, and the materials selected, will result in a product quality commensurate with the design criteria.

4.1

DEVELOPMENT TESTING

The design and development tests shall demonstrate that the final design of the TIS secondary subsystems will meet the requirements of this specification. These tests shall be used as a basis for design changes.

4.2

QUALIFICATION TESTING

These tests shall be performed to demonstrate compliance with this specification as regards design performance, life, and quality approval of secondary subsystems and major components.

4.3

ACCEPTANCE TESTING

Tests shall be performed on production articles to assure continued quality of the secondary subsystems in accordance with the requirements of this specification. Acceptance tests will be performed on all major components to assure that the quality and performance of equipment manufactured on a production basis is in compliance with this specification.

4.4

QUALITY VERIFICATION

Quality assurance provisions shall be in accordance with MIL-E-8189B and MIL-E-4158B.

4.5

DEMONSTRATION TESTING

The Test Instrumentation Subsystem will be demonstrated prior to AF acceptance to assure functional compliance with Dyna-Soar requirements.



5.0 NOTES AND SUPPLEMENTAL REQUIREMENTS

5.1 RANGE SUPPORT

Equipment and facilities required to support the Dyna-Soar Flight Test Program will normally be provided by the Range. Those items of the TIS that are peculiar to the Dyna-Soar Program and are of a non-continuing nature, will be supplied by the System Contractor. Specific items of equipment are noted in TAB "D", Table 3.1-1.

5.2 ASSOCIATE CONTRACTOR SUPPORT

Prior to the operational phase of the Dyna-Soar Test Program, functional testing and operational check-out of the Communications and Tracking Subsystem will be performed by the Associate Contractor and the Range. Since the Glider Instrumentation Subsystem will not be available for these tests, it will be the responsibility of The Boeing Company to provide tape recorded data for input to the airborne elements of the CTS that will simulate the composite signal output of the Glider Instrumentation Subsystem. The equipment required to produce this test tape will be located in the Data Systems Laboratory as noted in TAB "D", Table 3.1-1.

5.3 REAL-TIME DATA REQUIREMENTS

Real-time data will be acquired and displayed during the pre-launch and boost phases of the Ground Launch Test Program. Specific data and display requirements, as presently known, are specified in TAB "D".

5.4 DEFINITIONS

Major Repair - Cumulative replacement of modules and/or components that exceeds 20 percent of the set.



TAB "A"

GLIDER INSTRUMENTATION SUBSYSTEM

U3-4071-1000 (was SAC 1544-L-23)

5-22-62

BOEING	NO. D2-7868
	PAGE 15



1.0

SCOPE

This TAB Section of the specification establishes the performance, design, and testing requirements of the Glider Instrumentation Subsystem. These requirements are in addition to those set forth in Section I of this specification. The Glider Instrumentation Subsystem consists of the following major equipments:

- a) Transducers
- b) Signal Conditioners
- c) Patch Panels
- d) PCM Conversion Set
- e) FM Conversion Set
- f) Time Code Generator Set
- g) Data Tape Recorder
- h) Photographic Data Recorders



2.0

APPLICABLE DOCUMENTS

The following Government specifications and other publications are applicable to this TAB Section and form a part of the Test Instrumentation Subsystem performance specifications.

2.1

GOVERNMENT PUBLICATIONS

IRIG Document 104-60

IRIG Standard Time Formats

MIL-E-8189B

Electronic Equipment, Guided Missiles, General Specifications for

MIL-E-25366B

Electric and Electronic Equipment and Systems, Guided Missiles Installation of, General Specification for

2.2

NON-GOVERNMENT PUBLICATIONS

D2-7340

Dyna-Soar Master Data Measurements List

D2-7391

Specification, Characteristics of Glider Electric Power and General Requirements for Load Equipment

D2-7417-1

Specification for Dyna-Soar Communications and Tracking Subsystem

D2-7481

Electronic Packaging Requirements, Contract Procured Flight Equipment

D2-80396

General Requirements for Dyna-Soar Source Control Drawings and Design Procurement Specifications

Dwg. No. 25-80231

Test Instrumentation Subsystem - Airborne, Envelope of



3.0 GENERAL PERFORMANCE AND DESIGN REQUIREMENTS

3.1 SUBSYSTEM DESCRIPTION AND OPERATION

Figure 3.1-1 is a functional block diagram of the Glider Instrumentation Subsystem. Subsystem configuration is based on the data acquisition philosophy specified in Section I, Paragraph 3.2.3.

3.2 ENVIRONMENTAL REQUIREMENTS - NATURAL

The Glider Instrumentation Subsystem shall satisfy the TIS performance requirements while operating under the following environmental conditions. All major components, except for the Data Tape Recorder, Photographic Data Recorders, and Transducers, will be located in the equipment compartment. The Data Tape Recorder and Photographic Data Recorders are located in the pilot's compartment. If differences in environment exist for locations other than the equipment compartment, they will be noted in subsequent paragraphs.

3.2.1 Temperature

+25°F to +156°F. Equipment cooling gas will be provided as specified in Paragraph 3.2.7.

3.2.2 Pressure

10.0 psia to 15.0 psia.

3.2.3 Vibration

See Figure 3.2-1.



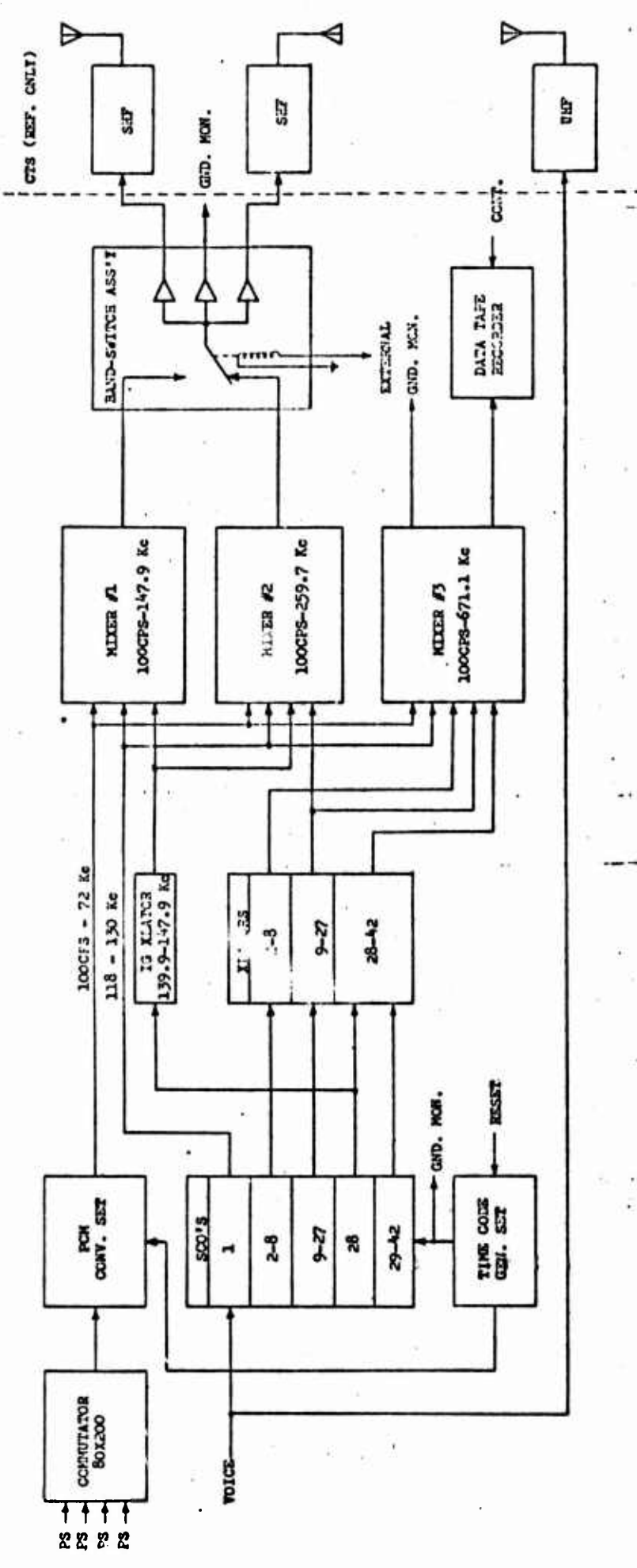

CA-C	REVISED	DATE	FILE
00000			716.3.1-1
00000			02-7668
00000			00-51
OLIDER INSTRUMENTATION SUBSYSTEM			BOEING AIRPLANE COMPANY

CA C	REVISED	DATE				
CHECK						
APP						
APP						
GLIDER INSTRUMENTATION SUBSYSTEM		BOEING AIRPLANE COMPANY				
FIG. 3.1-1		PAGE 19				

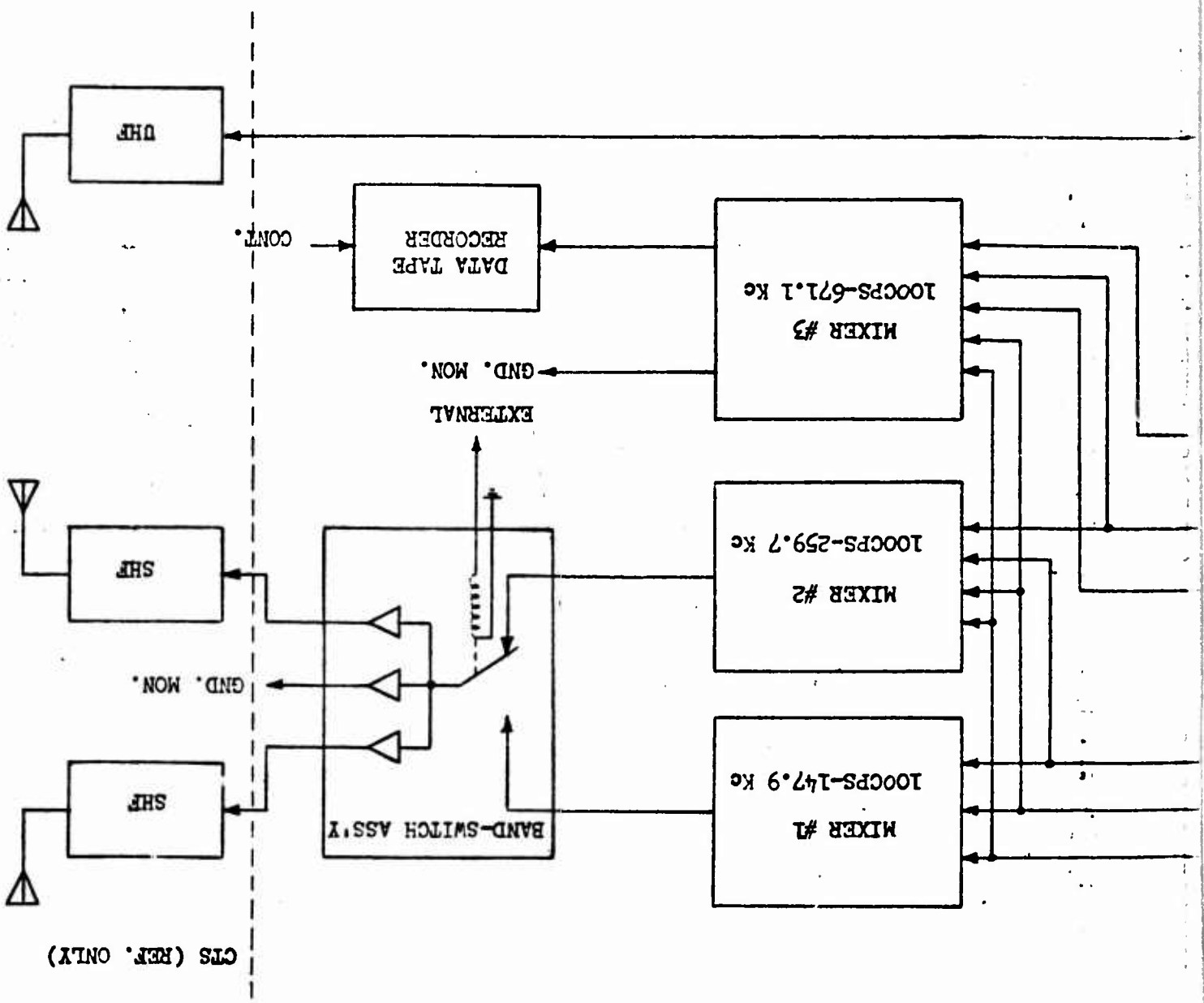

3.2.4 Acoustic Noise

See Figure 3.2-2.

3.2.5 Acceleration

See Document D2-7481, Appendix "A", Paragraph 3.3.

3.2.6 Shock

See Document D2-7481, Appendix "A", Paragraph 3.2.

3.2.7 Coolant

The equipment shall operate in the thermal environment specified in Paragraph 3.2.1 when supplied with nitrogen cooling gas at a maximum rate of 4 lbs./KW-minute of dissipated power, allowing a pressure drop between total equipment inlet pressure and outlet static pressure of 2 inches of water. Cooling gas will be supplied at a temperature between 45°F and 70°F.

3.2.8 Zero Gravity

The equipment shall operate satisfactorily under conditions of zero gravity, combined with the above environments, when supplied with the coolant of Paragraph 3.2.7.

3.3 ENVIRONMENTAL REQUIREMENTS - INDUCED

The Glider Instrumentation Subsystem shall satisfy the TIS performance requirements after being subjected to the following non-operating environments.

3.3.1 Temperature

-50°F to +212°F.

3.3.2 Pressure

1.04 psia to 23.0 psia.

3.3.3 Transportation Vibration

See Document D2-7481, Appendix "A", Figure 1.

3.4 OTHER ENVIRONMENTAL REQUIREMENTS

Except as specified in Paragraph 3.2 and Paragraph 3.3, the equipment shall meet the environmental requirements of Specification MIL-E-8189B.



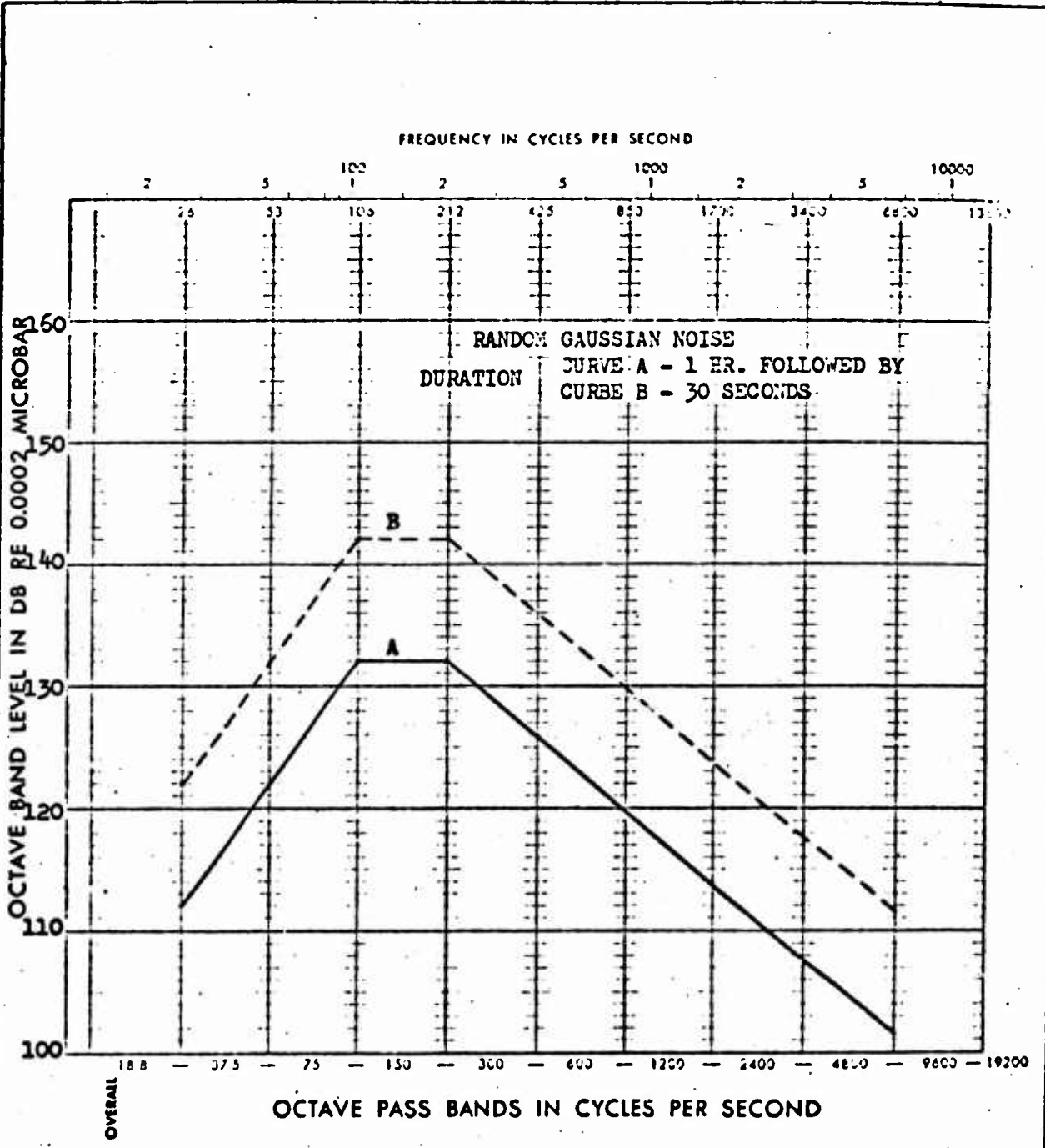

ACOUSTIC DESIGN ENVIRONMENT
 FOR EQUIPMENT LOCATED IN
 PILOT AND EQUIPMENT COMPARTMENT

S-22-62

BOEING | NO D2-7868
 | 3.2-2
 | PAGE 22 →

3.5

RELIABILITY

The Glider Instrumentation Subsystem shall have a reliability commensurate with the required reliability for the design mission of the TIS and shall be 0.01 or better for any 4 hour use period.

3.6

SIGNAL CAPACITY

The Glider Instrumentation Subsystem shall be capable of accepting a total quantity of data signals as established by the requirements of Document D2-7342.

3.7

GENERAL DESIGN REQUIREMENTS

The requirements of Specification MIL-E-8189B apply as requirements of this specification with the exceptions and additions noted. When the two specifications conflict, this specification shall govern.

3.8

ELECTRIC POWER

The Glider Instrumentation Subsystem shall perform satisfactorily under all conditions of available glider power as specified in Document D2-7391. The maximum allowable power demand is 1500 watts.

3.9

ELECTRONIC EQUIPMENT INSTALLATION

Where practical, the design shall conform to the requirements of Specification MIL-E-25366B.

3.10

PACKAGING

Documents D2-7481 shall be used as a guide for design and construction.

3.11

ENVELOPE

Equipment contained in the equipment compartment may take on any size or shape providing it stays within the envelope, and meets the mechanical interface requirements, of Boeing Dwg. No. 25-80231.

3.12

WEIGHT

The maximum allowable weight, including transducers and wiring, is 1000 lbs.

3.13

MAINTAINABILITY

The design shall provide for plug-in replacement of defective modules, and in accordance with Section I, Paragraph 3.3.7.



3.14

OUTPUT ISOLATION

Sufficient isolation shall be provided such that any one of the transmitter, recorder, or umbilical outputs will not be affected if any one or more of the other outputs are shorted.

3.15

BANDWIDTH SWITCHING

Fixed-bandwidth receiving capabilities will be established for each of the Range stations in accordance with the telemetry requirement philosophy stated in Section I, Paragraph 3.2.3. Automatic bandwidth switching will be provided for in the Glider Instrumentation Subsystem in keeping with this philosophy.

3.16

CONTROLS

The only switches available for control of glider power to the Glider Instrumentation Subsystem will be located in the pilot's compartment. Manual over-ride of the bandwidth switching function shall also be provided.

3.17

POWER REQUIREMENTS

Operation of the Glider Instrumentation Subsystem is dependent upon a supply of power as defined in Document D2-7391.

3.18

INTEGRATION WITH OTHER SUBSYSTEMS

The specific integration requirements for the Glider Instrumentation Subsystem with the other vehicle subsystems will require close coordination with the respective design groups to assure the integrity of the Dyna-Soar vehicle. Salient areas of integration are noted with the following subsystems:

3.18.1

Secondary Power Subsystem

The power requirements shall be compatible with the Secondary Power Subsystem as defined in Document D2-7391.

3.18.2

Structures

Size, weight, etc. are defined in Boeing Dwg. No. 25-80231.

3.18.3

Communications and Tracking Subsystem

Modulating signals are delivered to the Data Transmitters which are a part of the CTS as defined in Document D2-7417-1.



3.18.4

Other Subsystems

Signals will be provided by other subsystems that will require conditioning by the Glider Instrumentation Subsystem. Close coordination with the design groups will be required to insure proper impedance matching, isolation, etc.

3.18.5

Monitoring Devices

The design of the output monitoring points shall be compatible with the impedance, amplitude, power, etc. input requirements of the ground test facilities.

3.19

GROUND CHECK-OUT AND SUPPORT

Requirements are specified in TAB "F".



4.0 SPECIFIC PERFORMANCE AND DESIGN REQUIREMENTS

4.1 TRANSDUCERS

4.1.1 Description and Operation

Transducers are the devices used to sense physical phenomena, in which the magnitude of the applied stimulus is converted into an electrical signal that is proportional to the quantity of the stimulus. Also included in this category are those "signal sources" contained within other glider subsystems. Approximately 750 parameters will be measured for each Air Launch and Ground Launch vehicle as specified in Document D2-7342.

The transducers will be selected to meet the data-range and environmental requirements of Document D2-7342. Accuracies are dependent upon the requirements of Document D2-7342 combined with the electronic system limitations of Section I, Paragraph 3.2.1 and Paragraph 3.2.2. Environmental conditions are determined by location in or on the vehicle.

Extremes of data range and/or operating environment will require that new methods be invented, or that major modifications be performed on existing devices, to obtain a portion of the data as specified in Document D2-7342.

4.1.2 Calibration Requirements

Consistent with accuracy requirements, transducers will be procured with standard calibration curves to permit the maximum utilization of "curve-fitting" techniques. Acquisition of calibration data concerning "signal sources" and "Subsystem provided" transducers is necessary to satisfy the requirements of Document D2-7342 and will require close coordination with the vendors and subsystem design groups. Additional requirements are specified in TAB "F".

4.2 SIGNAL CONDITIONERS

4.2.1 Description and Operation

Signal Conditioners will be used to prepare the Transducer output signals into a form acceptable to the PCM or FM Conversion Sets, and to provide "signal accessibility" for test and calibration purposes. Individual Signal Conditioners are provided for each measurement.

4.2.2 Output Signals

- a) 0-20mv p-p or 0-5v p-p to PCM Conversion Set
- b) 2.0v p-p, 5.0v p-p or ± 25 mv to FM Conversion Set



4.2.3

Accuracy

Dependent upon accuracy of transducer or signal source, in conjunction with Section I, Paragraph 3.2.1 and Paragraph 3.2.2, to satisfy the requirements of Document D2-7342.

4.2.4

Packaging

The packaging density shall be such as to satisfy the weight and volume requirements of Boeing Drawing No. 25-80670 while still allowing a single Signal Conditioner circuit failure to affect the minimum number of data channels.

4.2.5

Test and Calibration Provisions

The design shall be such as to satisfy the test and calibration requirements of TAB "F". Typical design might be as shown in Figure 4.2-1.

4.2.6

Controls

All controls necessary to accommodate the test and calibration requirements specified in TAB "F" shall be readily accessible without removing any components from the subsystem, and adjustable without the use of special tools.

4.3

PATCH PANELS

4.3.1

Description and Operation

The purpose of the Patch Panels is to provide flexibility in Signal Conditioner utilization and channel sampling rate/frequency response selection. All Conversion Set signal input points, Signal Conditioner output signal points, and transducer power supply output points are terminated in the Patch Panels to provide this required flexibility.

4.3.2

Accuracy

The Patch Panel shall handle, without degradation of 0.1% or more, the signals specified in Paragraph 4.2.2.

4.3.3

Maintainability

Periodic servicing shall not be required.

4.3.4

Flexibility

Construction shall be such that patching may be accomplished by the use of pre-programmed plug-in units. The units shall be capable of being installed or removed without the use of special tools.



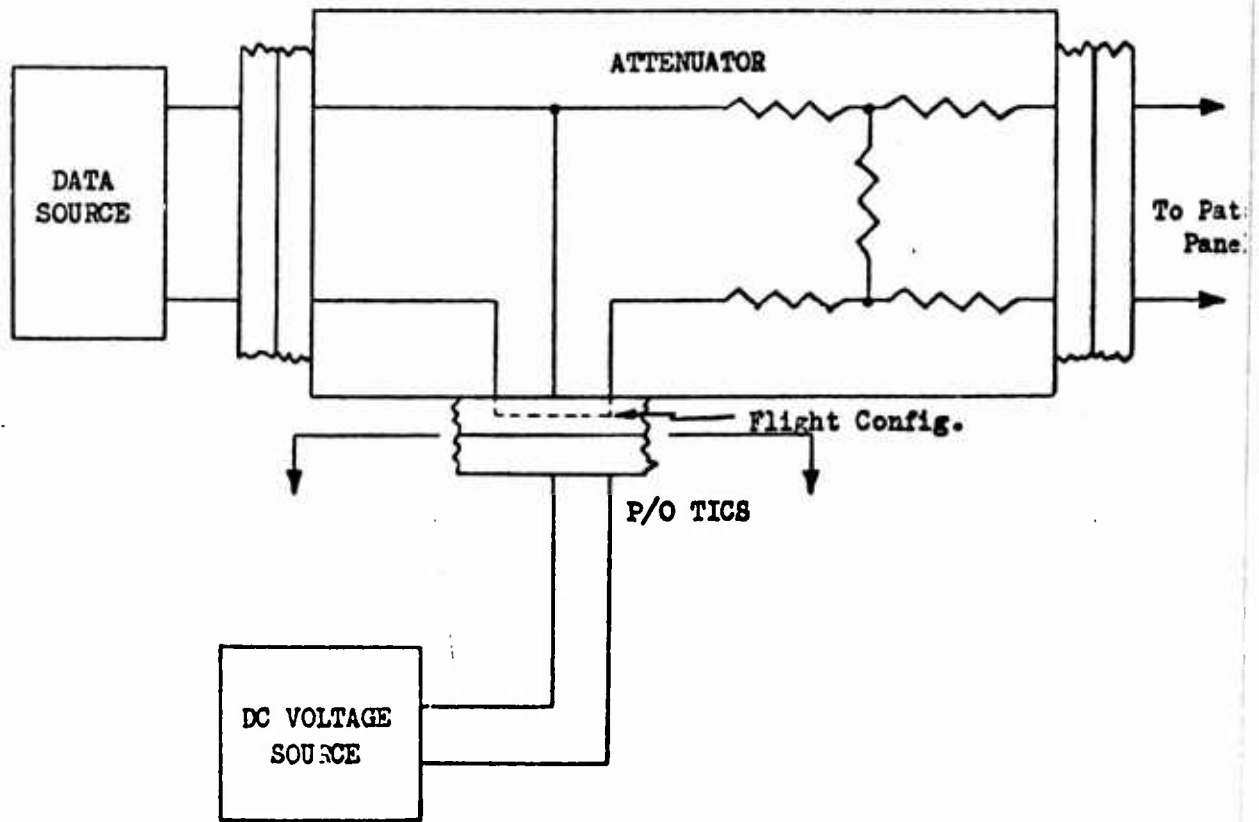

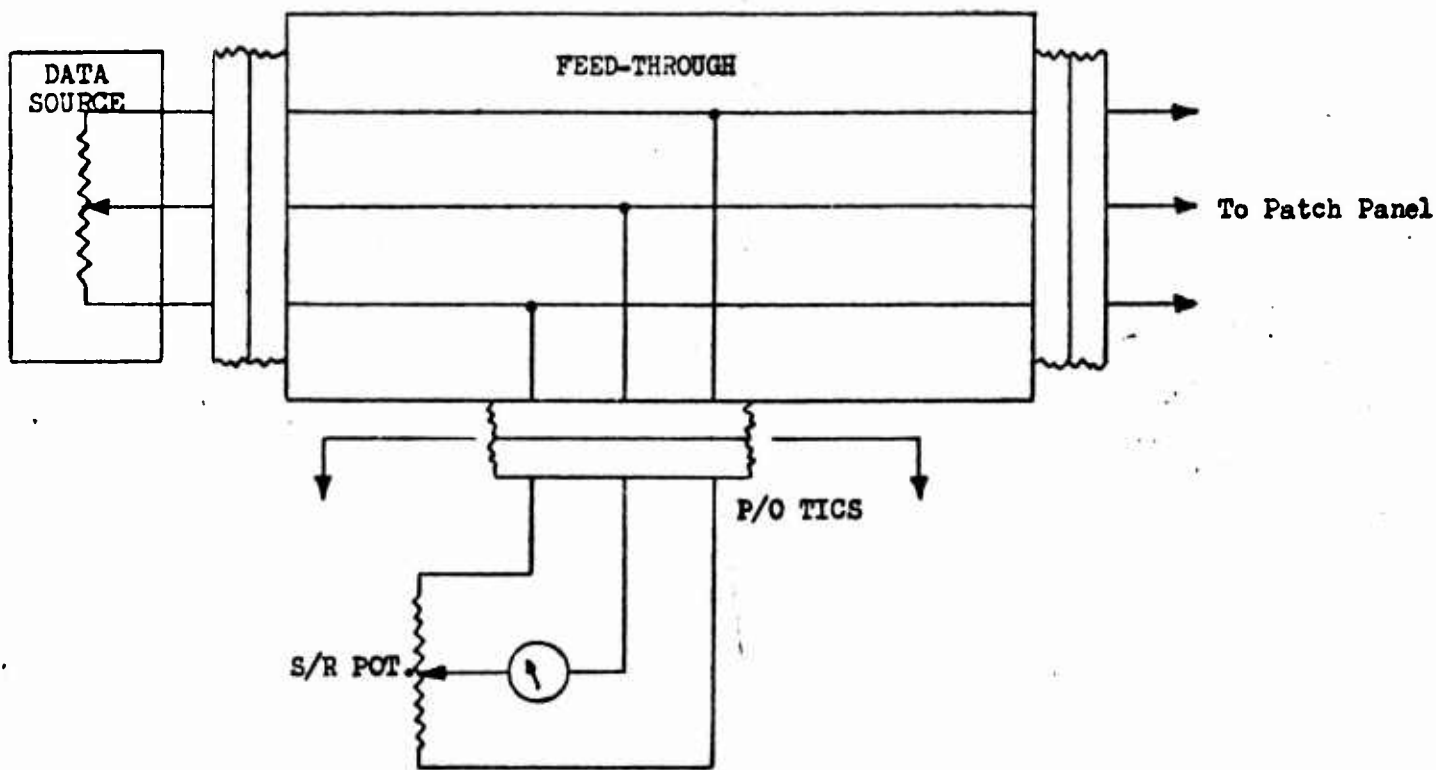

CALC		REVISED	DATE	SIGNAL CONDITIONERS TYPICAL CIRCUIT DESIGN BOEING AIRPLANE COMPANY	Fig. 4.2-1
CHECK					D2-7868
APR					PAGE
APP					28

4.4 PCM CONVERSION SET

4.4.1 Description and Operation

The function of the PCM Conversion Set is to sequentially sample the various analog data signals and convert these signals to a binary coded digital output signal. The digital pulse train is frequency-multiplexed with the output signals from the FM Conversion Set for input to the Data Transmitters and Data Tape Recorder.

4.4.2 Input Signals

Low level and high level signals of Para. 4.2.2 at maximum source impedance of 1000 ohms and 10,000 ohms, respectively. Common mode signals may be present at levels of ± 5 VDC @ 100 ohms or more and 1v p-p (up to 2500 cps) @ 100 ohms or more.

4.4.3 Channelization

<u>Basic Channels</u>	<u>Sampling Rates (sps)</u>	<u>Switch Points</u>
5-HL	2	500
20-HL	20	200
12-LL	20	120
8-HL	50	32
35-HL	200	35

4.4.4 Output Signal

NRZ pulse train at a bit rate of 144,000 bits/sec. Each digital word consists of an 8 bit binary number plus 1 odd parity bit.

4.4.5 Synchronization

Unique coded words shall be provided for basic frame and subcommutator frame synchronization.



4.4.6

Reliability

The maximum probability of failure shall be as specified in Paragraph 3.5 for any 20 or more data channels. Data channel failure occurs when the accuracy requirements of Section I, Paragraph 3.2.1, are not met.

4.4.7

Flexibility

Fixed-capacity modular construction shall be used for the 20 sps and 50 sps commutators with no more than 20 channels per module. There shall be cross-strapping provisions for the 200 sps channels.

4.4.8

Input Filtering

Each data input point shall be adequately filtered to minimize aliasing errors. The filters shall be compatible with the cross-strapping requirements of Paragraph 4.4.7.

4.4.9

Self-Test Capabilities

The PCM Conversion Set shall be provided with an independent and highly reliable isolated power supply to be used as the signal source for the in-flight error-detection channels, per the requirements of Section I, Paragraph 3.3.3. A sufficient number of channels will be used so as to adequately define system errors that may be compensated for during post-flight data processing.

4.5

FM CONVERSION SET

4.5.1

Description and Operation

The FM Conversion Set continuously monitors the various analog data signals and converts them to a frequency-modulated, frequency-multiplexed signal for input to the Data Transmitters and Data Tape Recorder. The FM Conversion Set contains the frequency translators necessary to satisfy the telemetry and on-board recording base-band requirements shown in Figure 3.1-1.

4.5.2

Channelization

42 channels, translated to those portions of the spectrum above the PCM spectrum as required to satisfy the telemetry and recording basebands.



4.5.3

Input Signals

Common mode signals of Paragraph 4.4.2 may be present. Data signals will be as follows:

<u>Channel</u>	<u>Amplitude</u> (V p-p)	<u>Frequency Response</u>	<u>Source</u> (Ohms)
1	2.0v p-p	300 cps - 3KC	150
2-4	5.0v p-p	dc - 110 cps	1K
5-15	+25mv	dc - 275 cps	1K
16-27	5.0v p-p(*)	20 - 1KC	1K
29-39	5.0v p-p(*)	20 - 2KC	1K
40-42	2.0v p-p	50 cps - 10KC	1K
28	5.0v p-p	dc - 2KC	1K

(*) May be +25 mv @ 1,000 ohms

4.5.4

Output Signals

Individual frequency-modulated signals translated above the PCM signal with lower band-edge and channel spacing chosen to maintain PCM and FM data accuracy requirements specified in Section I, Paragraph 3.2.1 and Paragraph 3.2.2.

4.5.5

Reliability

The maximum probability of failure of any one or more data channels shall be as specified in Paragraph 3.5. Data channel failure occurs when the accuracy requirements of Section I, Paragraph 3.2.2, are not met.

4.5.6

Flexibility

Flexibility shall be such as to permit a trade between data channel bandwidth and data accuracy. Bandwidth changes shall correspond to changes in VCO deviation ratios (3) of 1, 2, and 5. VCO's for channels 2-4, 5-27 and 29-39 shall be physically and functionally interchangeable.

4.5.7

Frequency Response

The individual VCO's shall have frequency and amplitude limiting adequate to maintain the accuracy requirements of Section I, Paragraph 3.2.2, under extremes of input signal frequency and voltage overdrive.



4.6 TIME CODE GENERATOR SET

4.6.1 Description and Operation

The TCG produces a coded time signal for input to the Data Tape Recorder, and a precision clock signal for input to the PCM Conversion Set. The timing signal is used to correlate airborne time with Range time. The clock signal is used by the PCM Conversion Set programmer.

4.6.2 Input Signal

The TCG shall begin to generate the coded time signal of Paragraph 4.6.3 upon receipt of the "command reset pulse" from the TCG Reset Control, TAB "D", Paragraph 5.9.6.

4.6.3 Output Signals

- a) Clock - 144 Kc
- b) Time Code - Format B, Option A, in BCD form as specified in IRIG Document 104-60. Day-of-the-year is not required.

4.6.4 Accuracy

The long-term accuracy of the coded output pulse train shall be 14.4 milliseconds over a 4 hour period, which requires the clock to have a frequency stability of 1 part in 1 million.

4.6.5 Reliability

The maximum probability of long-term failure shall be as specified in Paragraph 3.5. Long-term failure occurs when the output error exceeds 1 part in 1 million over a 24 hour period.

4.6.6 Anti-Spoofing

The reset circuitry shall be such as to recognize a uniquely-coded "reset command" signal, Reference Paragraph 4.6.2, in the presence of any noise that may appear on the umbilical line.

4.7 DATA TAPE RECORDER

4.7.1 Description and Operation

The function of the Data Tape Recorder is to store on magnetic tape the PCM data signal, all FM data signals, and the coded time signal acquired during the vehicle flight.

4.7.2 Input Signals

Shall be capable of recording continuously, for a two hour period, any data signal with a bandwidth from 100cps to 1 Mc.



4.7.3

Accuracy

The accuracy is determined from an input to the Data Tape Recorder to the output of the ground reproducer. There shall be no more than 1 bit error in 100,000 serial bits for the PCM data and no more than 10% probability of exceeding $\pm 2.5\%$ amplitude error for any FM channel.

4.7.4

Reliability

The maximum probability of set failure shall be as specified in Paragraph 3.5. Set failure occurs when the accuracy requirements of Paragraph 4.7.3 are not met.

4.7.5

Safety

The Data Tape Recorder will be located in the pilot's compartment and shall be designed so as not to contaminate the atmosphere of the pilot's compartment, and must be explosion-proof.

4.7.6

Mounting

The mounting shall be of the quick-disconnect type to allow for easy removal under emergency conditions.

4.7.7

Controls

The RECORD ON-OFF control shall be accomplished locally at the set or remotely through the umbilical cable. The recorder shall operate in the last mode selected when the umbilical is disconnected.

4.7.8

Monitor Output

An output signal that is a true indication of proper Tape Recorder operation, shall be provided for ground monitoring purposes.

4.8

PHOTOGRAPHIC DATA RECORDER

4.8.1

Description and Operation

The function of the cameras is to photograph the cockpit instrument panel display during the Air Launch and Ground Launch tests.

4.8.2

Field of View

The cameras shall be capable of viewing all panel instruments as specified in Document D2-7342.



4.8.3 Frame Rate - Panel Camera(s)

a) T-2 Min. to touchdown - 6 frames/sec.

4.8.4 Film Size

16 mm

4.8.5 Picture Quality

Optimum picture quality shall be obtained using a minimum of additional lighting in the pilot's compartment. Weight and power required for lighting shall be consistent with the limitations imposed on the Glider Instrumentation Subsystem.

4.8.6 Safety

Same as Paragraph 4.7.5.

4.8.7 Controls

A "Controller" shall be provided with the capability of turning the cameras on and off and of energizing the camera at the frame rates specified in Paragraph 4.8.3. The Controller "function" input signals will be supplied by a "timed" sequencer or by a "glider - function" sequencer.



5.0 TESTING REQUIREMENTS

5.1 DEVELOPMENT TESTING

The vendor shall submit Detail Equipment Specifications to Boeing on a regularly scheduled basis, per Boeing Document D2-80396. In addition to this, subsystem and system compatibility tests will be performed on a scheduled or "as-required" basis in order to verify certain design parameters, define problem areas, establish basic design criteria, optimize design variables, etc.

5.2 QUALIFICATION TESTING

Pre-production tests shall be accomplished on representative production prototype sets. The prototypes will be tested at the place of manufacture or at any approved testing laboratory to establish compliance with design requirements.

5.3 ACCEPTANCE/FUNCTIONAL TESTING

An acceptance test of each production set shall be performed at the place of manufacture to assure that the set is the equal of that which successfully passed the qualification tests. Functional tests shall be performed at Boeing in accordance with procedures contained in TAB "F".

5.4 DEMONSTRATION TESTING

The Glider Instrumentation Subsystem will be demonstrated prior to Air Force Acceptance to assure functional compliance with Test Instrumentation Subsystem requirements.



6.0

NOTES AND SUPPLEMENTAL REQUIREMENTS

6.1

DEFINITIONS AND ABBREVIATIONS

CTS	Communications and Tracking Subsystem
Major Component (Set)	The first order functional breakdown of the Glider Instrumentation Subsystem.
Range	Those elements of the Atlantic Missile Range and the Pacific Missile Range involved in the Dyna-Soar Test Program.
Signal Sources	Those signals generated by other glider subsystems for input to the TIS.
TCG	Time Code Generator
TIS	Test Instrumentation Subsystem
Umbilical	The last remaining ground test cable attached to the vehicle prior to lift-off.



TAB "B"

BOOSTER INSTRUMENTATION SUBSYSTEM

U3-4871-1000 (was BAC 1546-LR3)

5-22-62

BOEING	NO. D2-7868
	PAGE 37



BOOSTER INSTRUMENTATION SUBSYSTEM

Originally this TAB Section specified the performance and design requirements of the Booster Instrumentation Subsystem. This area is now the responsibility of the Booster Associate Contractor and the requirements have been removed from this specification.

The Booster Instrumentation Subsystem consists of a PCM/FM and FM/FM telemetry system that is completely independent of the Glider Instrumentation Subsystem. Ground data recovery, data processing, etc. are also an independent function and the responsibility of the Booster Associate Contractor.



TAB "C"

B-52 CARRIER INSTRUMENTATION SUBSYSTEM

U3-4071-1000 (was BAC 1646-L-83)

5-22-62

BOEING	NO. D2-7868
	PAGE 39



B-52 CARRIER INSTRUMENTATION SUBSYSTEM

Originally this TAB Section specified the performance and design requirements at the B-52 Carrier Instrumentation Subsystem. These requirements are now a part of the B-52 Modification Program and have been deleted from this specification.



TAB "D"

GROUND DATA RECOVERY SUBSYSTEM

5-22-62



1.0

SCOPE

This TAB Section of the specification establishes the performance and design requirements of the Ground Data Recovery Subsystem. These requirements are in addition to those set forth in Section I of this specification. For purposes of this TAB Section, the Ground Data Recovery Subsystem is defined as "those elements of the Test Instrumentation Subsystem required to obtain data during the ground and flight test activities of the Dyna-Soar Test Program".

The Subsystem consists of the following major components:

- a) Seattle Data Systems Laboratory
- b) AFFTC Instrumentation Trailer
- c) AFMTC Instrumentation Trailer
- d) AFFTC Permanent Base Test Lab
- e) Boeing Flight Test Control Center
- f) AMR-1 Telemetry Station.



2.0

APPLICABLE DOCUMENTS

The following Government documents and other publications are applicable to this TAB Section and form a part of the Test Instrumentation Subsystem performance specifications:

2.1

GOVERNMENT PUBLICATIONS

MIL-E-4158B

Electronic Equipment, Ground,
General Requirements for

IRIG 104-60

IRIG Standard Time Formats

2.2

NON-GOVERNMENT PUBLICATIONS

D2-7417-1

Specification for Dyna-Seoar
Communications and Tracking
Subsystem

D2-80426

Electronics Packaging Requirements-
Contract Procured Test Instrumen-
tation Subsystem Ground Equipment



3.0 FACILITIES AND LOCATION

3.1 SUBSYSTEM DESCRIPTION AND OPERATION

The Ground Data Recovery Subsystem includes all the equipment required at the Range stations to recover telemetered data, record it on magnetic tape, and furnish the real-time displays necessary for flight test control. The subsystem also includes those facilities at all locations to provide the Ground Check-out and support functions as specified in TAB "F". The specific items of equipment peculiar to each major component of the subsystem are shown on Table 3.1-1. The major components are as follows:

3.2 SEATTLE DATA SYSTEMS LABORATORY

The DSL functions as the main Seattle test facility. The DSL shall be capable of functionally testing all Glider Instrumentation Subsystem pre-production and production equipment, of supporting Systems Integration Laboratory tests, and of providing maintenance and repair facilities for all elements of the Test Instrumentation Subsystem. In addition to the equipment shown on Table 3.1-1, the DSL also contains the ancillary equipment necessary to satisfy the requirements specified in TAB "F". Figure 3.2-1 is a simplified functional block diagram of the DSL.



EQUIPMENT LOCATION	Communications & Tracking System	Predetection Recording System (IF Required by Range)	VHF Receiver (Broad-Band & Narrow-Band)	PCM Ground Station	FM Ground Station (Standard & Non-Standard)	Recorder/Reproducer A/B Data Tape	Remote Control A/B Tape Recorder	Time Code Generator	Reset Control A/B Time Code Generator
Range Station (AMR-1)	X	X		X	X	X			
Flight Test Control Center				X	X	X	X	X	X
Instrumentation Trailers				X	X	X	X	X	X
Data Systems Lab			X	X	X	X	X	X	X
Permanent East Test Lab (AFFTC)	X	X		X	X	X	X	X	X
Pre-Flight Test Areas (AFFTC)									
Pre-Launch Test Areas (AFMTC)									
Systems Integration Lab									

NOTE: This table not intended to show quantities or supplier.

Reproduced from
best available copy.

	Time Decoder & Display	PCM Computer Input Preparation Equipment	IG Data Equipment	IG Computer Input Preparation Equipment	IRIG FM Tape Preparation Equipment	Check-out Display Equipment	Real-Time Display Equipment	Self-Check Test Equipment	See TAB "F"						
									FM Simulator	PCM Command Code Gen.	Test Equipment A/B Conversion	Transducer Simulation Equipment	TIS Check-out Set (TICS)		
	X	X	X	X	X	X		X							
X			X			X	X	X							
X			X			X		X							
X	X	X	X			X		X			X	X	X	X	X
X	X	X	X	X	X	X	X	X							
															X
															X
															X

CA.C		REVISED	DATE	EQUIPMENT LOCATION TABLE	Table 3.1-1	
CHECK					BOEING AIRPLANE COMPANY	D2-7868
APR						PAGE 45
APR						

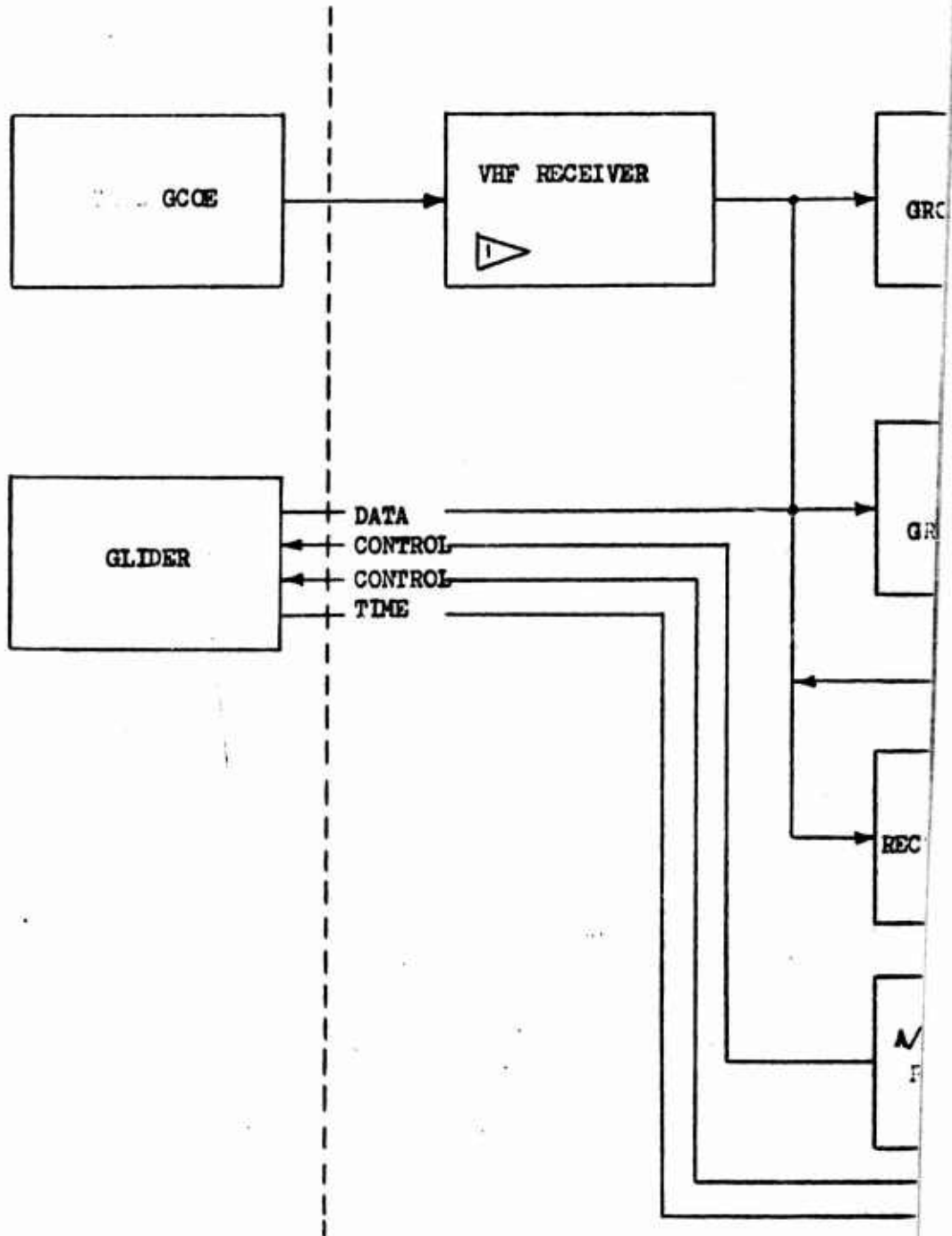

1  Identical to VHF receiver used with
 Range Predetection Recording System

3.3 AFFTC INSTRUMENTATION TRAILER

The Instrumentation Trailer will be used to support pre-flight testing of the glider and Glider Instrumentation Subsystem during the Air Launch Test Program. Figure 3.3-1 is a simplified functional block diagram of a typical instrumentation trailer.

3.4 AFMTC INSTRUMENTATION TRAILER

Performs the same function as the AFFTC trailer during the Ground Launch Test Program. Prior to use at AFMTC, this trailer will be used to support Titan III compatibility testing.

3.5 AFFTC PERMANENT BASE TEST LAB

This facility will be used to receive, record, and display glider telemetered data during the Air Launch Test Program. Figure 3.5-1 is a simplified functional block diagram of the AFFTC Test Lab.

3.6 AMR-1 TELEMETRY STATION

The AMR-1 Telemetry Station contains the ground elements of the Communications and Tracking Subsystem as specified in D2-7417-1 and the wide-band VHF telemetry receiver required to deliver the composite data signal to the FTCC. Boost Real-Time Data Transmission Equipment and Computer Input Preparation Equipment will also be located in this area. Figure 3.6-1 is a simplified functional block diagram of the Range station.

3.7 BOEING FLIGHT TEST CONTROL CENTER

The FTCC operates in conjunction with the AMR telemetry station to receive, record, and display glider telemetered data during the Ground Launch Test Program. The FTCC also supports glider pre-launch test activities. Figure 3.7-1 is a simplified functional block diagram of the FTCC. Both Pre-launch and Boost real-time data will be independently displayed in the operations area of the FTCC. The Pre-launch data will be extracted from the composite data signal received directly from the glider or the AMR-1 T/M station. Boost data, received from the AMR-1 and AMR-5 (San Salvador) T/M stations, will be available from the AMR cable facilities.

Both Pre-launch real-time data and Boost real-time data will be displayed in the operations area of the FTCC. The Pre-launch data will be received directly from the glider or from the AMR-1 T/M station.

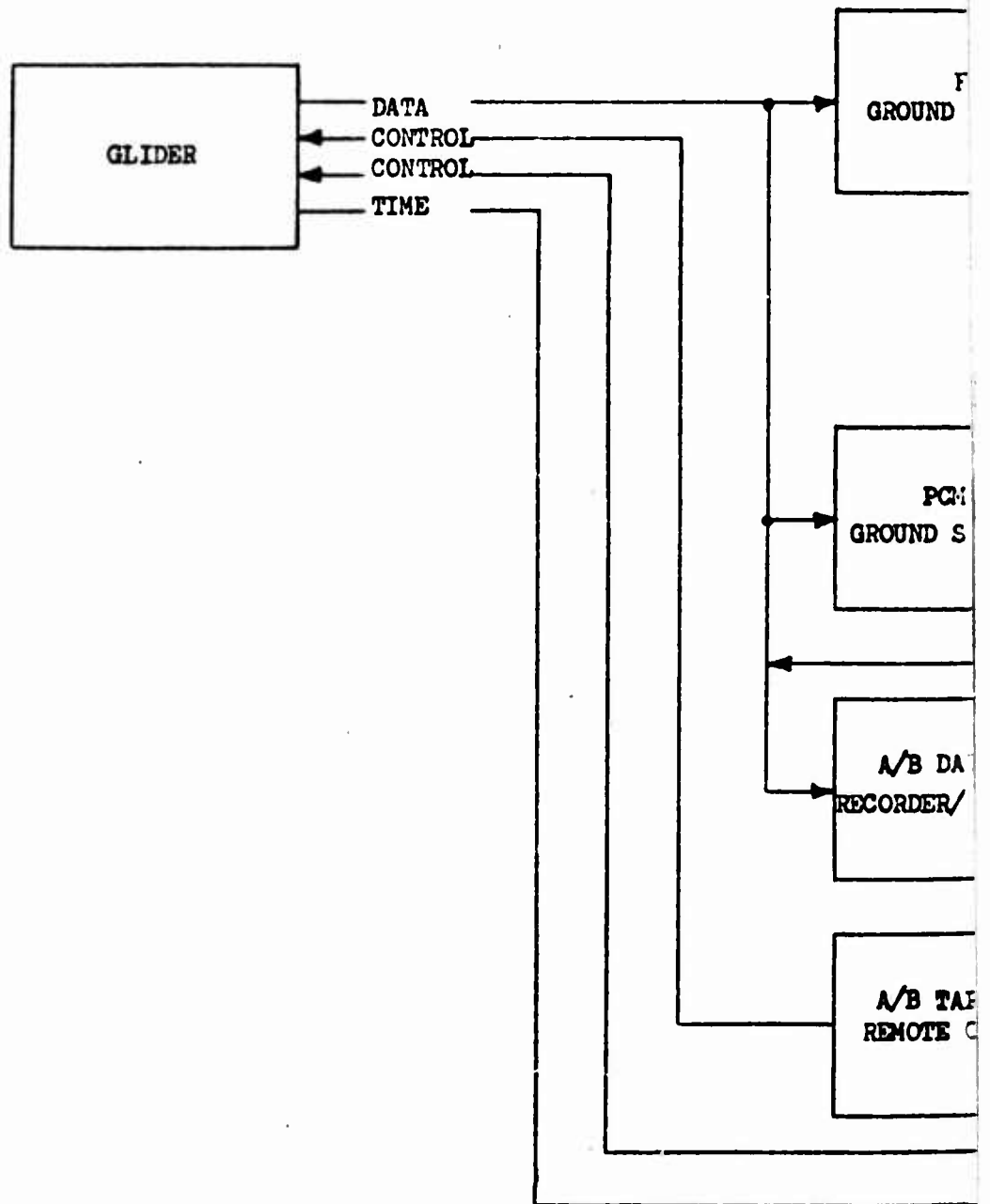

Reproduced from
best available copy.

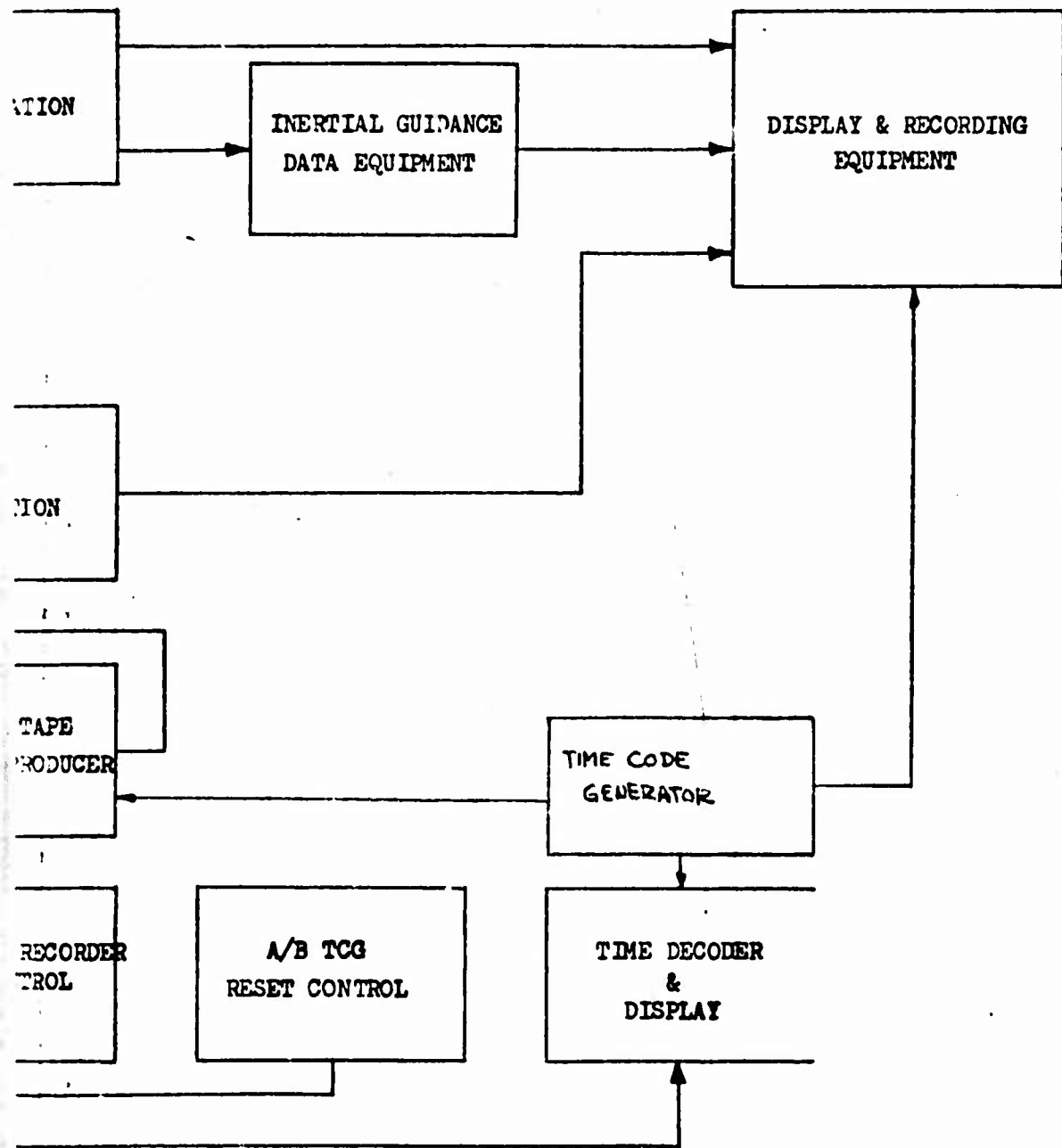

CALC		REVISED	DATE	INSTRUMENTATION TRAILER	Fig. 3.3-1	
CHECK					D2-7868	
APR					BOEING AIRPLANE COMPANY	PAGE
APR						48

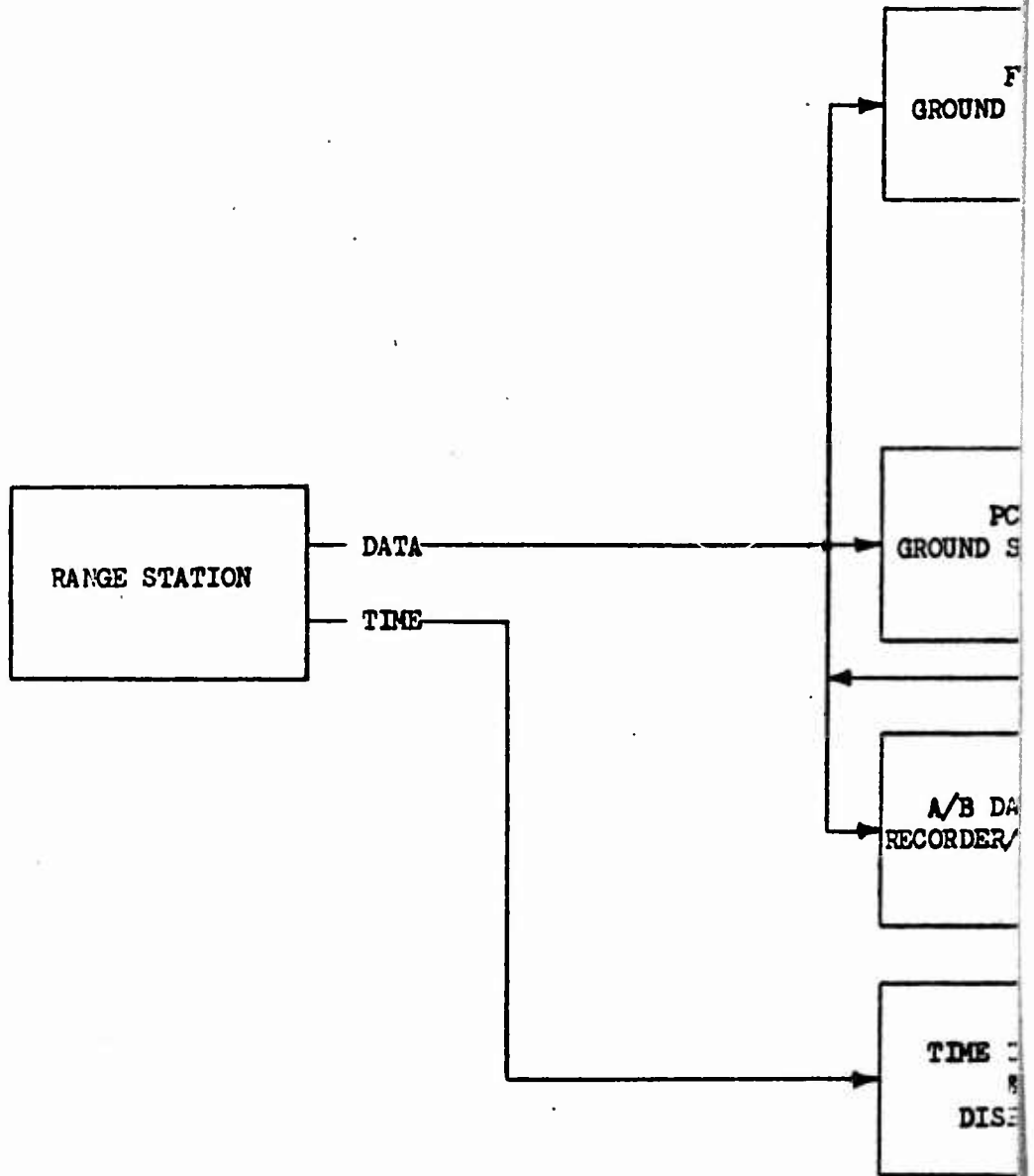

Reproduced from
best available copy.

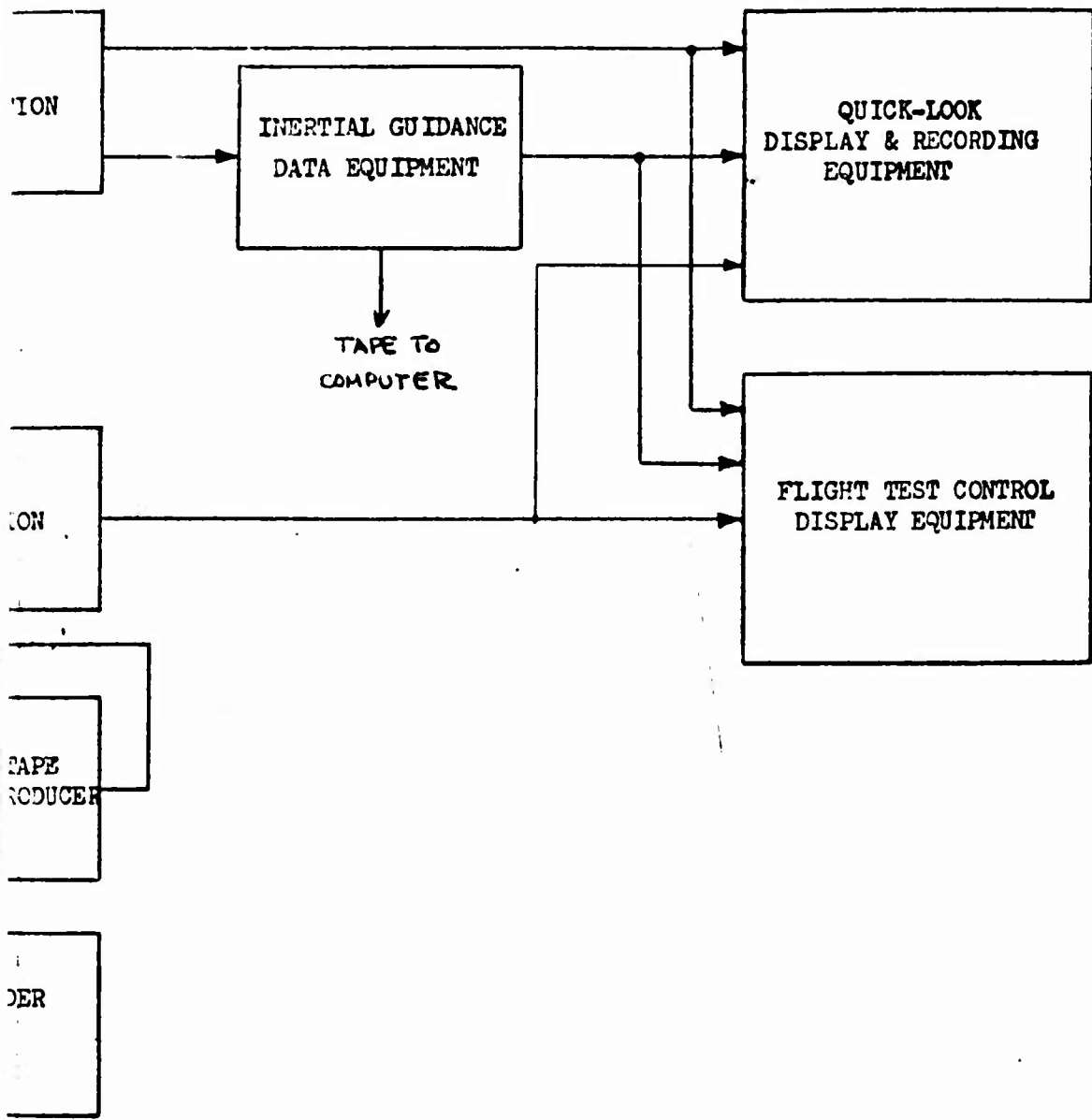

CALC		REVISED	DATE	PERMANENT BASE TEST LAB. AFFTC BOEING AIRPLANE COMPANY	Fig. 3.5-1
CHECK					D2-7868
APR					PAGE 49
APR					

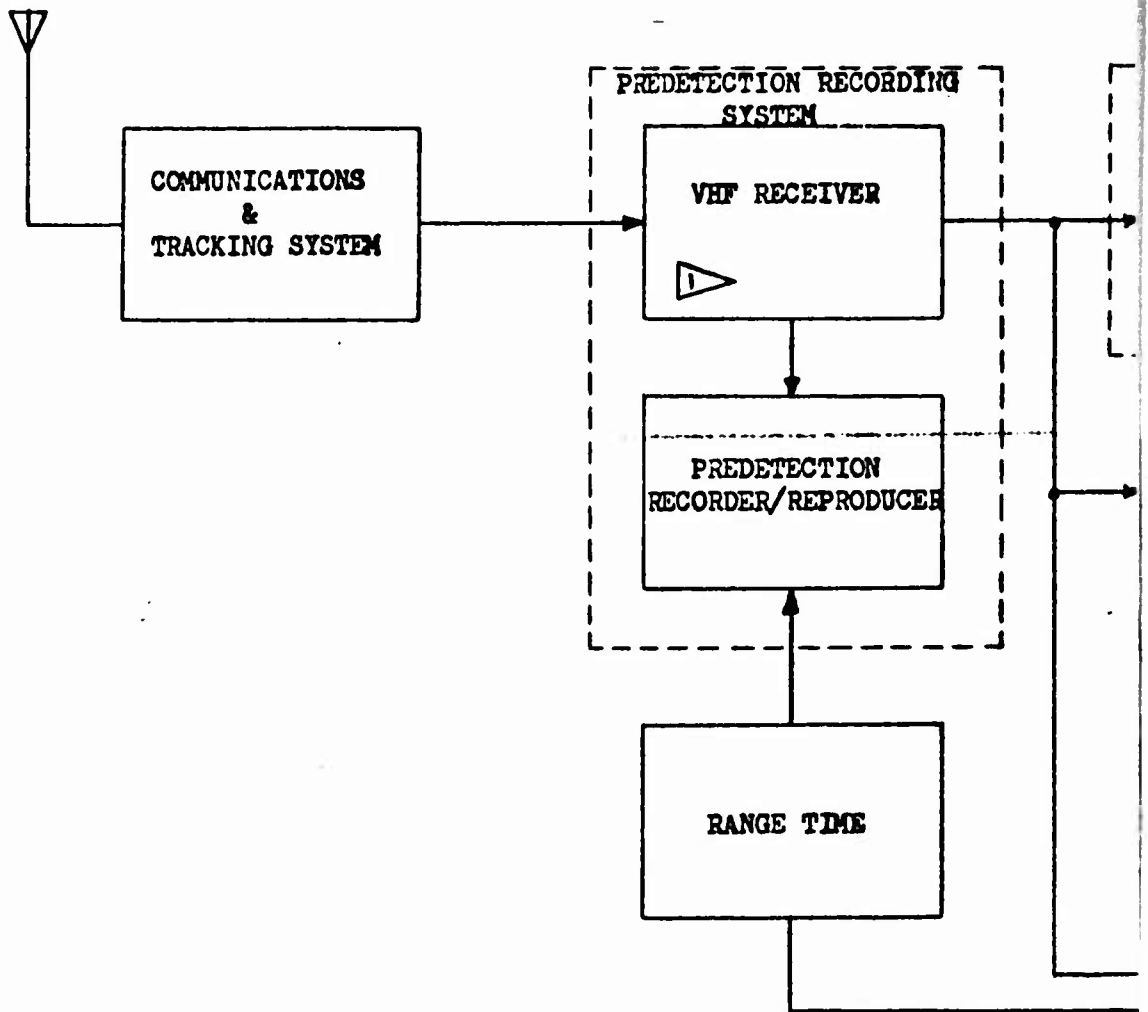

▷ If Bandwidth dependent upon station location

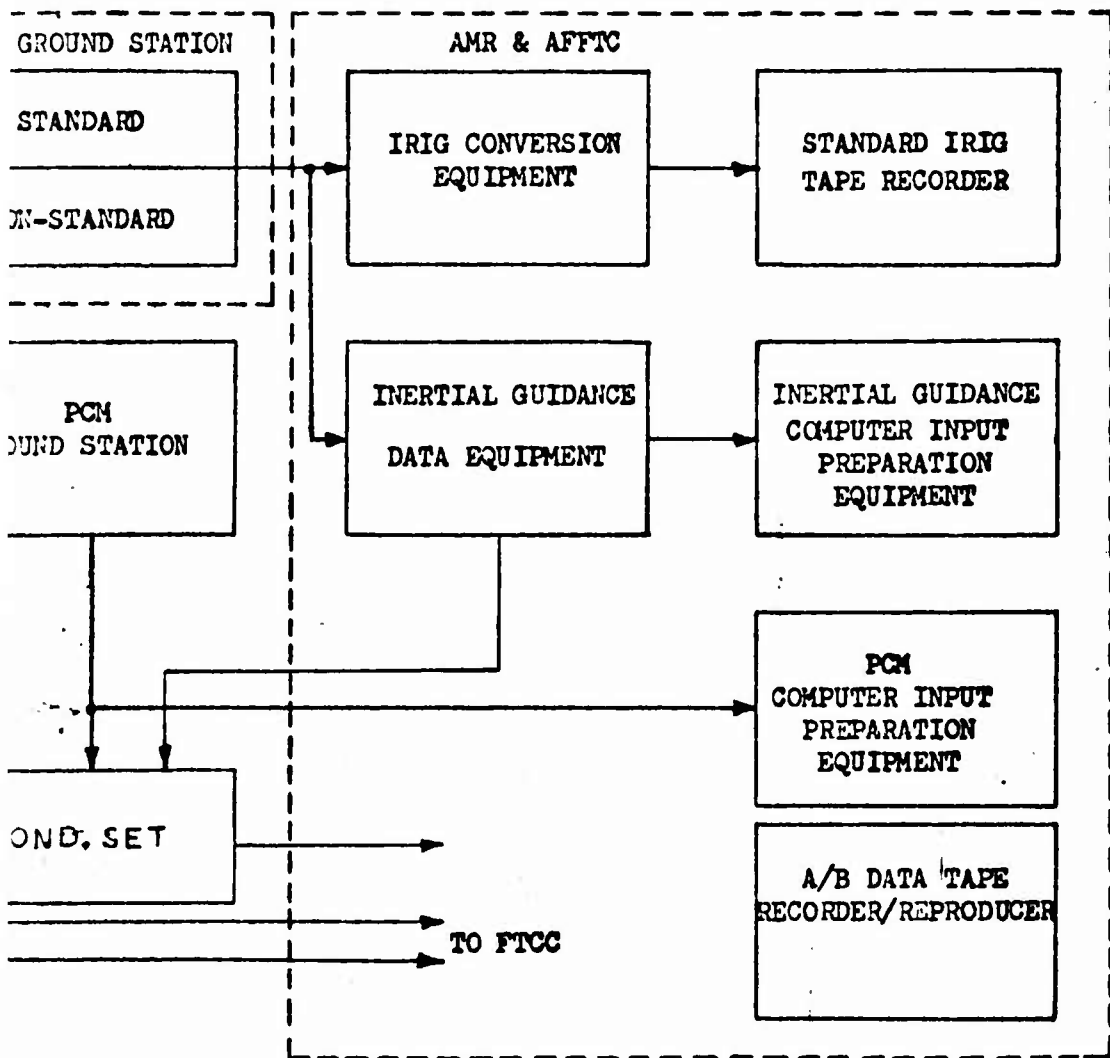

CA.C		REVISED	DATE	AMR RANGE STATION	Fig.3.6-1	
CHECK						
APR						D2-7868
APR					BOEING AIRPLANE COMPANY	PAGE 50-4

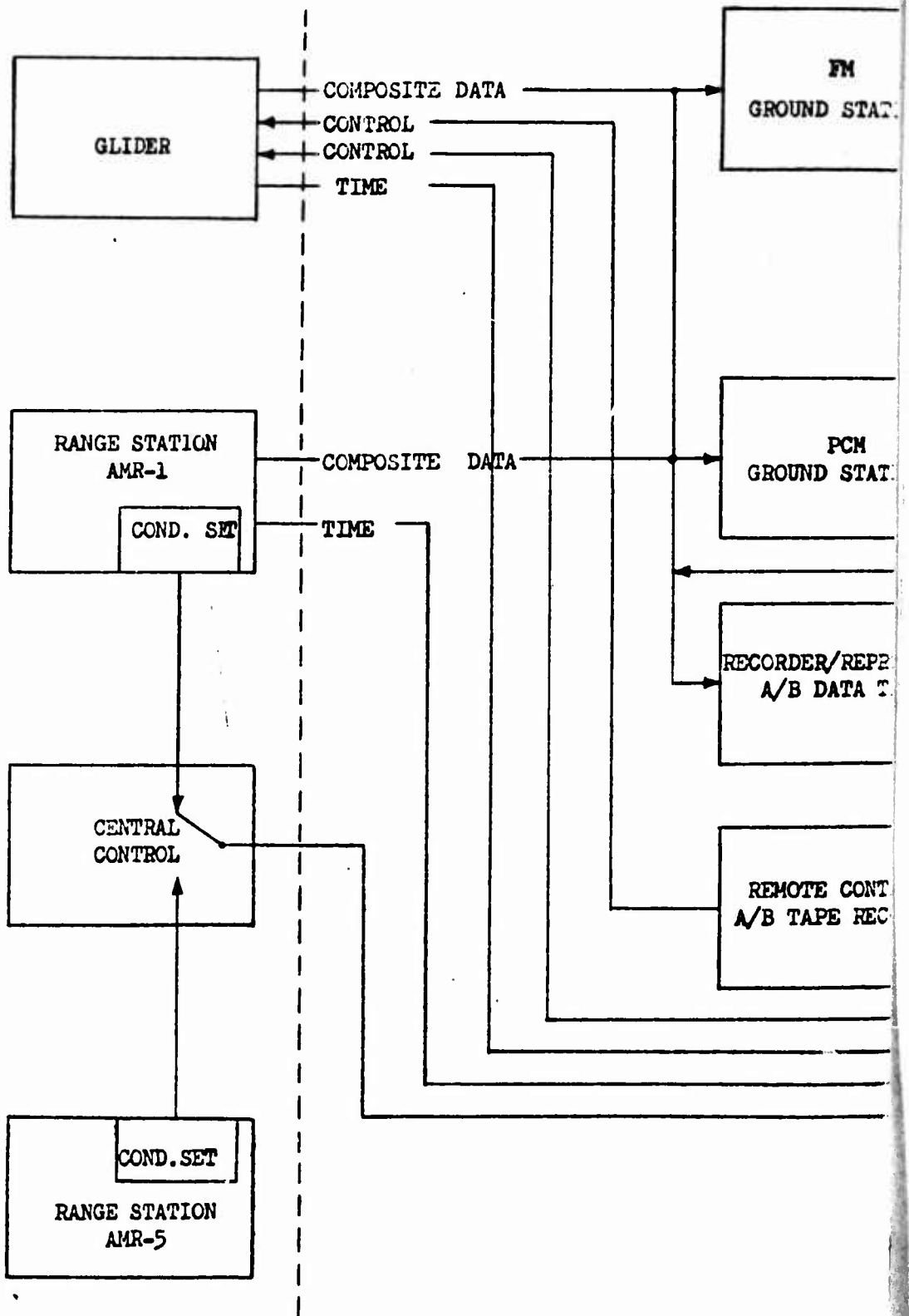

51-a

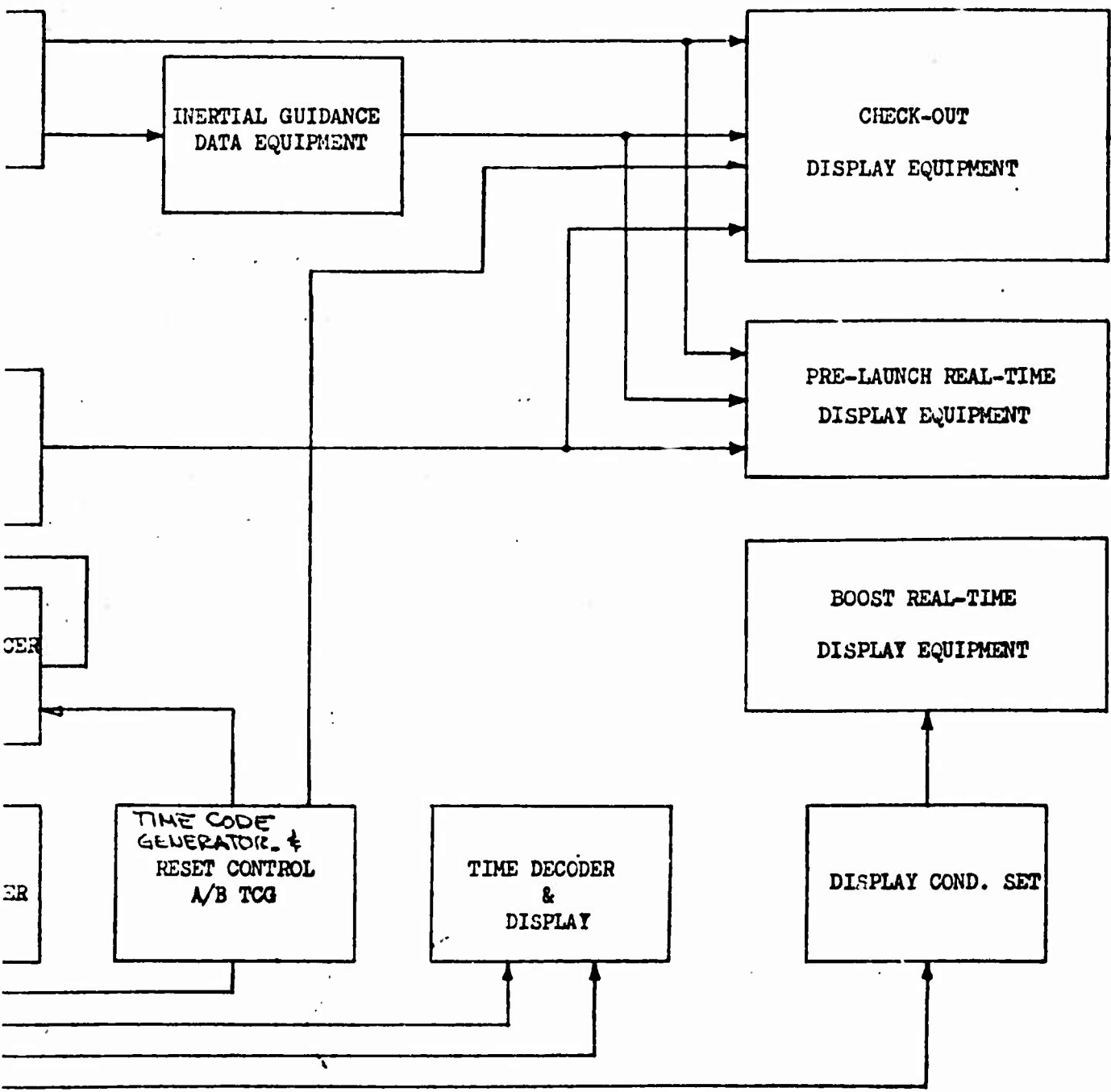

CALC		REVISED	DATE	AMR FLIGHT TEST CONTROL CENTER BOEING AIRPLANE COMPANY	Fig. 3.7-1
CHECK					D2-7868
APR					PAGE
APR					51-a

4.0

GENERAL PERFORMANCE AND DESIGN REQUIREMENTS

The following general requirements are applicable to all equipment provided for the Ground Data Recovery Subsystem. Requirements for specific items of equipment, to be provided at the locations shown on Table 3.1-1, are given in Paragraph 5.0.

4.1

OPERATING ENVIRONMENT

The equipment provided for each major component of the Ground Data Recovery Subsystem shall satisfy the TIS performance requirements when operating in a laboratory environment.

4.2

NON-OPERATING ENVIRONMENT

All equipment shall perform satisfactorily in accordance with Paragraph 4.1 after being subjected to the following non-operating environments.

4.2.1

Temperature

-50°F to +160°F.

4.2.2

Humidity

0 to 100%.

4.2.3

Fungus, Salt Spray, Sand and Dust

The unassembled components may be subjected to fungus growth as encountered in tropical climates, salt sea atmosphere at all locations, and sand and dust in desert areas.

4.2.4

Vibration, Shock and Acceleration

See Document D2-8023.

4.3

MAINTAINABILITY

The design of the equipment shall provide for installation with a minimum of special tools, handling equipment, and skills. The design must also provide for rapid servicing, inspection, fault detection and isolation, and test and calibration.

4.4

INTERCHANGEABILITY

Replacement of similar types of units shall not result in degradation of system performance and shall not require a major system readjustment.



4.5

SAFETY

The equipment shall be designed in accordance with specification MIL-E-4158B so as to provide maximum safety to personnel installing, operating, and maintaining the equipment.

4.6

SELF-TEST FEATURES

All components shall have output waveform monitoring points and a sufficient amount of built-in test equipment to satisfy the requirements of TAB "F". Test points used for normal testing shall be easily accessible on the front of the components.

4.7

INSTALLATION

The equipment shall be rack-mounted and provided with pull-out drawers where practical.

4.8

WEIGHT AND VOLUME

The volumes and weights shall be kept to a minimum consistent with good engineering practices.

4.9

COOLING

Cooling features as required to maintain safe operating temperatures shall be provided. These shall consist of independent blowers, filters, and control systems.

4.10

ELECTRIC POWER

All equipment shall operate from a non-regulated single-phase, 117/210V(+15%), 60 ±1 cps supply.

4.11

SELF-CHECK TEST EQUIPMENT

Self-check equipment shall be provided at each major facility to enable functional testing of the complete PCM and FM system. In addition, the self-check equipment shall verify the calibration of the individual stations by supplying accurate input test signals and accurately measuring the resultant output signals.

5.0 SPECIFIC PERFORMANCE AND DESIGN REQUIREMENTS

The following equipment shall be provided in accordance with the schedule shown in Table 3.1-1.

5.1 SHF ANTENNAS AND RECEIVERS (CTS)

Performance and design requirements as specified in Document D2-7417-1.

5.2 PREDETECTION RECORDING SYSTEM

This equipment, consisting of the VHF receiver and a predetection tape recorder/reproducer, is provided by the Range. The post-detected output is available to the PCM and FM Ground Stations. The VHF receivers furnished at the DSL shall be identical to those planned for AMR.

5.3 PCM GROUND STATION

5.3.1 Description and Operation

The function of the PCM Ground Station is to convert the serial PCM pulse train into time-correlated analog and digital output signals as required by the check-out display and recording equipment, real-time display equipment, and computer input preparation equipment.

5.3.2 Input Signals

The station shall be capable of operation with an input NRZ bit rate of 144,000 bits/sec. Synchronization and data word requirements are specified in TAB "A", Paragraph 4.4.4 and Paragraph 4.4.5. The PCM signal is contained within the composite telemetered and recorded basebands as shown in TAB "A", Figure 3.1-1. PCM-FM channel separation shall be accomplished by suitable filtering techniques so as to maintain the station accuracy as specified in Paragraph 5.3.5.

Input impedance and input amplitude dynamic range shall be consistent with the ability to accept data signals directly from the glider via the umbilical cable, from the Predetection Recording System, and from any of the data tape recorders specified herein. The station is required to accept data signals from only one source at a time.

5.3.3 Flexibility

For quick-look and real-time display purposes, the PCM Ground Station shall be capable of decommutating any combination of available channels. Programmable patch boards shall be provided to allow for selection of channels to be decommutated.



5.3.4 Output Signals

The station shall be capable, by means of programmable patch boards, of providing the following simultaneous outputs:

- a) Any sub-commutated or primary channel as an analog signal for CRT display.
- b) Any channel, in digital form, for display and/or printing.
- c) Digital output for computer input preparation.
- d) A maximum of any 60 channels, in analog form, for check-out and Pre-launch real-time display and 20 channels for trailer.

5.3.5 Accuracy

With an input peak signal-to-RMS noise ratio of 16db, the output shall contain not more than 1 error per 1 million bits.

5.3.6 Reliability

The maximum probability of failure of a single channel for any 10 minute operation period shall not exceed 0.01. Channel failure occurs when the accuracy requirement of Paragraph 5.3.5 is not met.

5.4 FM GROUND STATION

5.4.1 Description and Operation

The function of the FM Ground Station is to convert FM information to time-correlated analog signals for display and recording and for input to the IRIG FM Conversion Equipment.

5.4.2 Input Signals

The station shall be capable of accepting the composite telemetered and recorded basebands as shown in TAB "A", Figure 3.1-1. FM-PCM Channel separation shall be accomplished by suitable filtering techniques so as to maintain the station accuracy as specified in Paragraph 5.4.5. Signals may originate from any of the sources specified in Paragraph 5.3.2.

5.4.3 Flexibility

The station shall have the capability of converting into analog voltages all standard and non-standard channels, as specified in SCC 10-31003.

5.4.4 Output Signals

Output signals shall be available to the display and recording equipment, to the Inertial Guidance Data Equipment, and to the IRIG FM Conversion Equipment.

5.4.5

Accuracy

There shall be no more than 10% probability of exceeding 10% amplitude error for any data channel.

5.4.6

Reliability

MTBF shall not be less than 1000 hours. Failure occurs when the accuracy of Paragraph 5.4.5 is exceeded and cannot be corrected by normal adjustment. Station calibration shall be required no more frequently than once every 24 hours.

5.5

NON-STANDARD FM CONVERSION EQUIPMENT

5.5.1

Description and Operation

The function of this equipment is to make existing Range FM stations capable of processing the non-standard FM channels.

5.5.2

Integration Requirements

Modifications shall be made with minimum change to existing equipment and shall be such that the accuracy and reliability of the modified station shall be equal to, or better than, the unmodified station.

5.6

INERTIAL GUIDANCE DATA EQUIPMENT

5.6.1

Description and Operation

This equipment shall be capable of accepting and decommutating 1 channel from the FM Ground Station. Channel frequency and bandwidth requirements will be determined from the input signal parameters specified in Paragraph 5.6.2.

5.6.2

Input Signal

The input will be both positive and negative data in serial binary NRZ pulse format with the following configuration:

- a) Bit rate - 3200 bits/second.
- b) Frame rate - 6.25 frames/second.
- c) Word format - consists of 12 data bits, with the least significant bit first, followed by a sign bit and an even parity bit.
- d) Frame format - 24 data words plus one synchronization word per frame.
- e) Frame synchronization - 00000000000011.
- f) Bit synchronization - alternate ones and zeros, starting with a bit opposite to that of the parity bit, are inserted between the data words. Time period between words in a frame is variable, but fixed from frame-to-frame.



5.6.3

Output Signals

The station shall be capable of providing the following output signals:

- a) Any one of the 25 data and sync channels for binary and decimal display.
- b) Any 6 channels in analog form for oscillograph recording.
- c) An output in parallel binary format suitable for driving the IG Computer Input Preparation Equipment (TAB "E", Paragraph 4.2).

5.6.4

Accuracy

Same as Paragraph 5.3.5.

5.6.5

Reliability

Same as Paragraph 5.3.6

5.7

A/B DATA TAPE RECORDER/REPRODUCER

5.7.1

Description and Operation

The function of the Recorder/Reproducer will be to reproduce the data recorded by the A/B Data Tape Recorder (TAB "A", Paragraph 4.7.1) and to record the signals available from the glider (TAB "A", Figure 3.1-1). The unit shall perform these functions with the same accuracy and reliability as specified in TAB "A" for the A/B Data Tape Recorder.

5.7.2

Controls

The Recorder/Reproducer shall contain local controls for Start, Stop, Record, Reproduce, Fast Forward, and Fast Rewind. There shall be provisions for remote control of Record and Reproduce.

5.8

A/B TAPE RECORDER REMOTE CONTROL

This unit shall be capable of remotely controlling the RECORD and STANDBY functions of the A/B Data Tape Recorder (TAB "A", Paragraph 4.7.7). The unit shall also contain a display of recording time, in minutes, remaining on the tape reels of the A/B Data Tape Recorder.



5.9 TIME CODE GENERATOR

5.9.1 Description and Operation

The function of the TCG is to furnish coded time-of-day signals suitable for magnetic tape recording, editing and processing of data.

5.9.2 Input Signal

The TCG shall begin to accumulate time upon receipt of a command pulse from an external source.

5.9.3 Output Signal

Format B, Option (a), in BCD form as specified in IRIG Document 104-60. Day of the year is not required.

5.9.4 Accuracy

The coded output shall be accurate to at least 1 part in 1 million for a 24 hour period.

5.9.5 Reliability

MTBF shall be at least 1000 hours.

5.9.6 Synchronization Output

A "command reset pulse" shall be available to the A/B TCG and shall satisfy the "anti-spoofing" requirements as specified in TAB "A", Paragraph 4.6.6. The signal shall be initiated by manual control and shall be synchronized to the integral minute of the TCG.

5.10 TIME CODE GENERATOR RESET CONTROL

A separate control module shall be provided to be used independently of the Time Code Generator (Paragraph 5.9) and shall be used to perform the function described in Paragraph 5.9.6.

5.11 CONDITIONING SET - REAL-TIME DATA DISPLAY

The function of the Real-Time Data Display Conditioning Set is to remove the data from the Range net and to condition the signals for input to the Real-Time Display Equipment. This equipment will be furnished by the Range and will be located in the FTCC.



5.12**REAL-TIME DISPLAY EQUIPMENT**

Analog and digital display equipment will be required to conduct both the Air Launch and Ground Launch test programs. This data will be displayed on meters, charts, plots, lights, etc.

The real-time display equipment will consist of two independent systems displaying the Pre-launch real-time data and the Boost real-time. The Pre-launch data will consist of approximately 100 channels which will be removed, by the FTCC ground station equipment, from the composite signal received directly from the glider or the AMR-1 T/M station. The Boost data will consist of approximately 50 channels which will be received from the Range cable facilities. Real-time data distribution system is shown on Figure 3.7-1.

5.13**CHECK-OUT DISPLAY EQUIPMENT**

Display and recording equipment will be required during the test program in support of glider testing and routine maintenance and calibration activities. The following specific types of equipment shall be provided in support of these activities:

- a) Time Decoder and Display - receives coded time signals from Range terminal units, time code generators, and tape recorders and decodes the time into a form suitable for decimal display and strip chart recording.
- b) Binary and Decimal Digital Displays - displays the output from a single PCM channel as a decimal number.
- c) Digital Printer-prints, in decimal form, the output from a single PCM channel and the Time Decoder.
- d) CRT Display - capable of displaying a maximum of 100 data channels at sampling rates of 2, 20, 50 or 200 sps.
- e) Recording Oscillograph - records up to 36 analog data channels available from any source within the area in which it is installed.
- f) Direct Write Recorder - records up to 8 analog data channels plus 2 channels of event information available from any source within the area in which it is installed.



6.0

TESTING REQUIREMENTS

6.1

ACCEPTANCE (VENDOR FUNCTIONAL) TESTS

Each production item shall be tested for compliance with all specified performance and design requirements. The vendor shall provide, as part of his design, recommendations for acceptance testing of each set. Recommendations shall include a description of suggested test procedures and recommendations and sketches of test equipment and facilities to demonstrate specification compliance.

6.2

TBC FUNCTIONAL TESTS

TBC shall functionally test all production sets for compliance with the performance and design requirements, in accordance with the manufacturer's procedures and recommendations. TBC will also perform any other tests it deems necessary to verify design and performance compliance.



7.0

NOTES AND SUPPLEMENTAL REQUIREMENTS

Supplemental requirements are defined in Document D2-8055-1, "Test Instrumentation Subsystem Design Procurement Specification", 7-1-62.

7.1

DEFINITIONS AND ABBREVIATIONS

A/B	Airborne
DSL	Data System's Laboratory
FTCC	Flight Test Control Center
IG	Inertial Guidance
Range	Those elements of the Atlantic Missile Range and the Pacific Missile Range involved in the Dyna-Soar Test Program.
Real-Time	The time at which an event is noted to occur, delayed only by propagation and electronic processing from the time of its actual occurrence.
TCG	Time Code Generator
TIS	Test Instrumentation Subsystem



TAB "E"
DATA PROCESSING SUBSYSTEM



1.0

SCOPE

This TAB Section of the specification establishes the performance and design requirements of the Data Processing Subsystem. These requirements are in addition to those set forth in Section I of this specification. The Data Processing Subsystem includes those components required to produce computer input tapes and IRIG FM tapes from data collected by the Test Instrumentation Subsystem. The Data Processing Subsystem receives input data from the Ground Data Recovery Subsystem, specified in TAB "D", and consists of the following major components:

- a) PCM Computer Input Preparation Equipment
- b) IG Computer Input Preparation Equipment
- c) IRIG FM Tape Preparation Equipment



2.0

APPLICABLE DOCUMENTS

The documents and publications specified in TAB "D", Paragraph 2.0, are applicable to this TAB Section.

5-22-62



3.0

GENERAL PERFORMANCE AND DESIGN REQUIREMENTS

All sub-paragraphs under 4.0, TAB "D", apply to this specification.

3.1

EQUIPMENT LOCATIONS

Data processing equipment will be located in Seattle, AFFTC and AFMTC as shown in TAB "D", Table 3.1-1.



3.0

GENERAL PERFORMANCE AND DESIGN REQUIREMENTS

All sub-paragraphs under 4.0, TAB "D", apply to this specification.

3.1

EQUIPMENT LOCATIONS

Data processing equipment will be located in Seattle, AFFTC and AFMTC as shown in TAB "D", Table 3.1-1.



AIRBORNE CONVERSION				GROUND RECOVERY		IRIG CONV.		PLAYBACK
Ch.	SCO Freq. Kc	Translated Freq. Kc	Frequency Response	Detranslated Frequency Kc		SCO Freq. Kc	Track	IRIG LFOF cps
2	7.35	137.0	110cps	7.35	110cps	•	1	110
5	7.35	143.9	275cps	7.35	275cps	22.0		330
16	25.0	173.0	1Kc	25.0	1Kc	40.0		1200
28	25.0	270.7	2Kc	50.0	2Kc	70.0		2100
3	7.35	139.0	110cps	7.35	110cps	•	2	110
6	7.35	146.2	275cps	7.35	275cps	22.0		330
17	25.0	180.7	1Kc	25.0	1Kc	40.0		1200
29	25.0	286.1	2Kc	50.0	2Kc	70.0		2100
4	7.35	141.6	100cps	7.35	110cps	•	3	110
7	7.35	148.5	275cps	7.35	275cps	22.0		330
18	25.0	188.4	1Kc	25.0	1Kc	40.0		1200
30	25.0	301.5	2Kc	50.0	2Kc	70.0		2100
8	7.35	150.8	275cps	7.35	275cps	22.0	4	330
19	25.0	196.1	1Kc	25.0	1Kc	40.0		1200
31	25.0	316.9	2Kc	50.0	2Kc	70.0		2100
9	7.35	153.1	275cps	7.35	275cps	22.0	5	330
20	25.0	203.8	1Kc	25.0	1Kc	40.0		1200
32	25.0	332.3	2Kc	50.0	2Kc	70.0		2100
10	7.35	155.4	275cps	7.35	275cps	22.0	6	330
21	25.0	211.5	1Kc	25.0	1Kc	40.0		1200
33	25.0	347.7	2Kc	50.0	2Kc	70.0		2100
11	7.35	157.7	275cps	7.35	275cps	22.0	7	330
22	25.0	219.2	1Kc	25.0	1Kc	40.0		1200
34	25.0	363.1	2Kc	50.0	2Kc	70.0		2100
12	7.35	160.0	275cps	7.35	275cps	22.0	8	330
23	25.0	226.9	1Kc	25.0	1Kc	40.0		1200
35	25.0	378.5	2Kc	50.0	2Kc	70.0		2100
13	7.35	162.3	275cps	7.35	275cps	22.0	9	330
24	25.0	234.6	1Kc	25.0	1Kc	40.0		1200
36	25.0	393.9	2Kc	50.0	2Kc	70.0		2100
14	7.35	164.6	275cps	7.35	275cps	22.0	10	330
25	25.0	242.3	1Kc	25.0	1Kc	40.0		1200
37	25.0	409.3	2Kc	50.0	2Kc	70.0		2100
15	7.35	166.9	275cps	7.35	275cps	22.0	11	330
26	25.0	250.0	1Kc	25.0	1Kc	40.0		1200
38	25.0	424.7	2Kc	50.0	2Kc	70.0		2100
27	25.0	257.7	1Kc	25.0	1Kc	40.0	12	1200
39	25.0	440.1	2Kc	50.0	2Kc	70.0		2100
1	124.0	124.0	3Kc	124.0	3Kc	•	13	Voice

*Direct Record

CALC		REVISED	DATE	IRIG FM CONVERSION	Fig. 4.3-1	
CHECK		5-22-62			D2-7868	
APPD					BOEING AIRPLANE COMPANY	PAGE
APPD						67

5.0

TESTING REQUIREMENTS

See TAB "D", Para. 6.0

5-22-62



5.0

TESTING REQUIREMENTS

See TAB "D", Para. 6.0



TAB "F"

GROUND CHECK-OUT AND SUPPORT SUBSYSTEM

5-22-62



1.0

SCOPE

This specification establishes the performance requirements of the Ground Check-out and Support elements of the Test Instrumentation Subsystem. The Ground Check-out and Support elements include the equipment required at Seattle, AFMTC and AFMTC to test and calibrate all portions of the Glider Instrumentation subsystem.

This Section is arranged to show the requirements for the following:

- A. In-plant Tests
- B. Out-plant Tests
- C. In-plant Calibrations
- D. Out-plant Calibrations



2.0

IN-PLANT TESTS

In-Plant Testing is defined as that portion of the pre-launch test program occurring in the Seattle area. The Seattle test program will consist of pre-installation testing of the airborne equipment performed in the Data Systems Lab (DSL) and post-installation testing of the airborne equipment performed in the Systems Integration Lab (SIL) and supported by the DSL. SIL testing will be performed in the Bldg. 2.01 SIL area and at several other testing areas physically removed from Bldg. 2.01.

All equipment shown in TAB "D", Table 3.1-1 will be required to support these functions. In addition to these, equipment will be required to accomplish the following specific tests.

2.1

GROUND STATION TESTS

2.1.1

Operational Tests

These tests are designed to functionally test all elements of the PCM and FM Ground Station. Equipment required, and procedure used, will be specified by the subcontractor.

2.1.2

PCM Accuracy Test

The PCM accuracy test will require a programmed tape (of sufficient length to insure that the bit error is less than 1 in one million) to provide a source of PCM signals for an accuracy and response check. The PCM signals will be recorded on tape and will be generated by a Command Code Generator to provide a known pattern having a recurring cycle that will agree with the major frame rate. The PCM data on the test tape will consist of 220 channels as follows:

1. 100 channels having nine programmed bit steps (0, 1, 3, 7, 15, 31, 63, 127, and 255) to check the binary code logic and the digital to analog converters. The nine programmed bit steps were chosen to check zero and every "all-one" binary number appearing in the sequence
2. 100 channels having six programmed bit steps (0, 50, 100, 150, 200, and 250) to check the linearity and frequency response of the strip chart recorder channels and the linearity of the other displays.
3. 10 consecutive words of zero count per basic frame to check linearity on the low end.
4. 10 consecutive words of 255 counts per basic frame to check linearity on the high end.



2.1.2

(Continued)

The format converter will be tested with a known input in which each major frame is identical to the preceding major frame. The output tape generated from this test will be checked by a computer for individual bit validity. Bit errors will be printed out with respect to time and location in the word frame. An error summary will also be printed out at the end of the computer run. A format converter output tape of six minutes in length will provide more than 5×10^7 bits for a system evaluation to the specification value of less than one bit error in 10^9 bits. The format converter input tape may also be used to verify the PCM station at the starting and ending of an operational day.

2.1.3

FM Accuracy Test

The FM accuracy test will require a programmed tape to provide nine frequencies for each channel at the translated frequency. The FM test tape will require dynamic and static recordings for checking dynamic response, linearity, band-edges, and center frequencies. This tape will be generated by the use of a precision laboratory oscillator and will be used for station verification after station installation. This tape will also be used to verify the station after adjustments have been made at the starting and ending of an operational day.



2.2

AIRBORNE TEST INSTRUMENTATION SUBSYSTEM ACCURACY EVALUATION TESTS

The airborne Test Instrumentation Subsystem accuracy evaluation tests will evaluate the prototype conversion equipment of the Glider Instrumentation Subsystem and will qualify all subsequent production units for installation in the glider. These tests will determine the compatibility, and establish the status, of the subsystems in their specific configurations. By using a computer program, test duplication and recording time will be minimized. Minimizing test time and duplication will provide qualified equipment with a high reliability factor due to low equipment use time and will also reduce support equipment requirements.

Three types of Glider Instrumentation Subsystem accuracy evaluation tests will be performed in the Data Systems Laboratory: a conversion and storage equipment test, a Glider Instrumentation Subsystem reference test, and a pre-installation and alignment test. The results of the airborne subsystem reference test will be used to evaluate the total airborne subsystem and will be used as a reference for tests in the Systems Integration Laboratory closed area, at the AFFTC, and at the AFMTC.

2.2.1

Airborne Conversion Equipment Test

The airborne conversion and storage equipment test will determine the accuracy of the conversion and storage equipment in a specific configuration.

This test will be comprised of three test sequences in which the PCM input will remain the same but the FM inputs will be changed as specified. The PCM output will be processed by a computer program that will be programmed to determine a level at the beginning of a record and each change of level. The computer will obtain this level from 25 consecutive tolerance samples that will be determined by input control data. If the input data goes out of tolerance from a previously determined level, and 25 consecutive samples occur within the specified tolerance, a new average level will be determined by the computer, and a printout will be produced from the previous level. The computer program will printout all data out of format but record will still be made. The FM output will be stripped-out on oscillographs and analysed for error.

The following equipment will be tested according to the programmed flight configuration:

1. PCM conversion equipment
2. FM conversion equipment
3. Time code generator and clock
4. Airborne tape recorder



2.2.2

Airborne Test Instrumentation Subsystem Reference Tests

The Glider Instrumentation Subsystem reference tests will establish an end-to-end subsystem accuracy evaluation of the entire airborne subsystem to the extent that glider-installed transducers and wiring will be simulated electrically in the Data System Laboratory. These tests will be performed on the prototype and all production equipment, the prototype unit being tested in the configuration of the first ground launch vehicle. These tests will establish a reference to be used to evaluate similar reference tests performed in the Systems Integration Laboratory and at the AFTIC and AFITC. A transducer simulator will be built to simulate all transducers electrically and will be designed for maximum flexibility and ease of operation. The simulator will also provide for a means of simulation of a measurement on all transducer simulation modules. The wire from the signal conditioners in the test console to the transducer simulation console must be electrically equivalent to the vehicle wiring but not necessarily of the same physical characteristics.

These reference tests will evaluate the following equipment:

1. PCM conversion equipment
2. FM conversion equipment
3. Time code generator
4. Airborne tape recorder
5. Signal conditioners

2.2.3

Pre-Installation Alignment Test

The pre-installation alignment test will be the last test performed on the airborne conversion and storage equipment prior to installation in the glider vehicle. The test will check the sub-carrier output voltage from zero input voltage through band-edge and will verify the compatibility of the composite PCM and FM signal with the input requirements of the transmitter.

2.3

SYSTEMS INTEGRATION LABORATORY TESTS

The Test Instrumentation Subsystem Systems Integration Laboratory tests will qualify the entire Glider Instrumentation Subsystem after installation in the Glider vehicle. Two types of tests will be performed in the Systems Integration Laboratory area: acceptance tests and design integration tests.

2.3.1

Functional Tests

The Test Instrumentation Subsystem Systems Integration Laboratory acceptance tests will be a functional check of the entire airborne subsystem including the following type

2.3.1 (Continued)

tests: transducer and signal conditioner balancing and functional test, conversion equipment test, channel calibration, Test Instrumentation Subsystem reference tests, Guidance Subsystem test, Communication and Tracking subsystem test, total vehicle compatibility test, and a repeat of the Test Instrumentation Subsystem reference tests.

2.3.2 Design Integration Tests

The Test Instrumentation Subsystem Design Integration Tests will consist of a one-of-a-kind testing where subsystem design parameters will be investigated to verify the physical, and functional capability and compatibility of the integrated subsystem. This document will consider only those tests that pertain to the Test Instrumentation Subsystem, glider subsystem integration test, and glider/B-52 compatibility tests. The test plan for each test will be as follows:

Prior to the test, a subsystem reference test (described in 5.1) will be performed on the subsystem to determine its status. Status data will be recorded using the airborne tape recorder. The subsystem will be operated during the test and the resulting airborne tape recording data will be processed and compared to the reference test data.



3.0 OUTPLANT TESTS

3.1 AFMTC ASSEMBLY AND TEST AREA

Present planning requires no Test Instrumentation Subsystem testing in the assembly and test area unless the glider vehicle is assigned to this area for some other reason. If this occurs a complete subsystem test, as outlined in Para. 2.3.1 will be accomplished.

3.2 AFMTC LAUNCH SITE

A check of those channels considered mandatory for flight will be accomplished at the launch pad. This test will be basically the same as the Functional Test specified in para. 2.3.1.

3.3 AFFTC CONFIGURATION CHANGE VERIFICATION TESTS

A complete Test Instrumentation Subsystem test, as outlined in Para. 2.3.1, will be performed on the glider vehicle after each Test Instrumentation Subsystem configuration change. This test will verify the new subsystem configuration for flight.

3.4 AFFTC PRE-FLIGHT AND POST-FLIGHT TESTS

During all pre-flight and post-flight tests at the AFFTC, the Test Instrumentation Subsystem will be monitored to determine channel status before and after each flight. The data will be recorded for future reference.

4.0 IN-PLANT CALIBRATIONS

4.1 LABORATORY CALIBRATIONS

4.1.1 Transducers

Laboratory calibrations will be performed using the procedures and equipment specified in Document D2-12324. In general, transducers will be procured with standard calibration curves. This technique has the following advantages:

- a) Recalibration is not required when transducers or signal conditioners are replaced
- b) Data processing work-load reduced by having a single calibration curve for many transducers
- c) Reduced calibration time
- e) Simplified configuration control

Where the above technique cannot be used, due to accuracy requirements or transducer design, the following general rules will apply:

- a) Maximum number of sense levels will be 30, including hysteresis
- b) Transducers using high-temperature wire will be colabrated with an equivalent wire resistance
- c) Thermocouple calibration will be calculated from National Bureau of Standards, or Vendor standards, of output millivolts vs temperature
- d) Full-scale output will be equivalent to 250 counts.

4.1.2 Signal Conditioners

For signal conditioners associated with curve-fitted transducers, the signal conditioner transfer function will be computed and applied to the transducer calibration curve. Where curve-fitting techniques are not used, transducers and signal conditioners will be calibrated together in accordance with the procedure contained in Document D2-80204-0, Section 2.0.



4.2

GLIDER CALIBRATION

Glider calibration will only be performed on those transducers where a laboratory calibration cannot be accomplished, or on those channels where the accuracy will be significantly improved by performing an end-to-end calibration.

4.3

GENERAL

In most instances, transducers will be supplied as part of the TIS. Where this is not the case; i.e., transducers provided as component parts of other glider subsystems or, signal sources not requiring transducers where the signal is derived from circuitry within the subsystem, close coordination with the subsystem design groups will be required to insure compatibility with Para. 4.0 and to satisfy the requirements of D2-7342.



5.0 OUT-PLANT CALIBRATIONS

5.1 AFFTC

Laboratory calibrations will be performed on an "as required" basis by the AFFTC Instrumentation Lab. These calibrations will be performed in a manner that will satisfy the requirements of Para. 4.0.

5.2 AFFTC

Laboratory calibrations will not be performed at AFFTC. Calibrated spares will be delivered with the glider or will be available from Seattle stores. Only that equipment deemed necessary to verify transducer and signal conditioner calibration will be provided.

