

AD-757 289

SOVIET NAVAL DIGEST, NUMBER 8, 1972.
SELECTED TRANSLATIONS

Naval Intelligence Support Center
Washington, D. C.

6 February 1973

DISTRIBUTED BY:

NTIS

**National Technical Information Service
U. S. DEPARTMENT OF COMMERCE
5285 Port Royal Road, Springfield Va. 22151**



DEPARTMENT OF THE NAVY
 NAVAL INTELLIGENCE SUPPORT CENTER
 TRANSLATION SERVICES DIVISION
 4301 SUTTLAND ROAD
 WASHINGTON, D. C. 20390

AD 757289

SELECTED TRANSLATIONS

from

**МОРСКОЙ
 СБОРНИК**

**SOVIET NAVAL
 DIGEST**

8

DDC
RECEIVED
 MAR. 18 1973
 B

Reproduced by
 NATIONAL TECHNICAL
 INFORMATION SERVICE
 U.S. Department of Commerce
 Springfield VA 22151

19



72

NISC TRANSLATION
 NO. 3396

DATE 6 February 1973

DISTRIBUTION STATEMENT A

Approved for public release;
 Distribution Unlimited

R
 66

Details of illustrations in
this document may be better
studied on microfiche.

TABLE OF CONTENTS

DECISIONS OF THE 24TH CPSU CONGRESS BROUGHT TO LIFE

It Is Imperative to Confidently Orient Yourself in the Situation and to Make a Correct Appraisal of the Events, by Admiral S. F. Sizov -----	*
--	---

THE 50TH ANNIVERSARY OF THE FORMATION OF THE USSR

Our Indissoluble Union, by Captain 1st Rank Yu. Moroz -----	*
Navies in War and in Peace, by Admiral of the Fleet of the Soviet Union S. G. Gorshkov -----	1
With The Ships, Units, and Forces of the Fleet -----	15
Navymen--Heroes of the Soviet Union -----	*

THE NAVAL ART

The Development of Small Combatants and Methods of Their Employment, by Admiral V. Alekseyev -----	22
---	----

COMBAT AND POLITICAL TRAINING

Patrol Boatman School, by Captain 1st Rank V. Piskunov and Captain 3rd Rank Yu. Kossov -----	32
A Difficult, But Honorable Service, by Captain 1st Rank A. Kananadze -----	*
True to the Precepts of Our Fathers, by Captain- Lieutenant L. Buchinskiy -----	*
Presenting an Example, by Captain 3rd Rank V. Petrov -----	*
The Courage of the Search, by Major-Engineer A. Kontin -----	*

* Not Translated. Note: Those articles indicated as not being translated may be translated at a later date. They will be published in a supplementary issue.

Distant Tracks, by Captain 2nd Rank A. Kuklev -----	*
The Cause--Irresponsibility -----	*
In the Ancient Land of Morocco, by Captain 2nd Rank P. Ablamonov -----	*

THE PAGES OF HISTORY

Gunboats in the Battle for Stalingrad, by Captain 1st Rank-Engineer I. Plekhov and Captain 1st Rank S. Khvatov (Retired) -----	*
The Battle of Dickson Island, by Rear Admiral K. Stepin -----	*
Ships on a Pedestal, by V. Redanov -----	*
Breathing Modernity Into Museum Exhibitions, by Captain 1st Rank I. Kuleshov -----	*

ARMAMENT AND TECHNOLOGY

The Effect of Own Acoustic Interference of A Ship On Sea ch Effectiveness -----	35
Sonar Beacons Used by NATO Nation Forces, by Captain 2nd Rank-Engineer B. B. Shishkin and Captain-Lieutenant Engineer V. Peterkov -----	39
The International Weather Observation System in the Ocean, by K. Konstantinov -----	*

PHENOMENA OF NATURE

Tyagun [Surge], by K. Vasil'yev -----	*
Air Space Regulations, by Captain of Justice A. Zhdanovich ----	42

FOREIGN FLEETS

Carrier-based ASW Helicopters, by Colonel-Engineer A. Ivanov --	49
Foreign Naval Chronicle -----	*
Torpedo Boats of the Navies of the Capitalist Countries -----	57

CRITIQUE AND BIBLIOGRAPHY

Friendship Tested by Time, by Major I. Gass (Reserves) -----	*
Changes in the Breadth of the Territorial Sea of Gabon and Cameroon, by V. Minin -----	62
Despite Deficiencies--A Valuable Handbook, by N. Pavlov -----	*
Ballad of the Sea, by Natal'ya Avgustinovich -----	*

Note: Due to reproduction problems, photographs have been omitted from this issue. Their captions will be found at the end of each article.

NAVIES IN WAR AND IN PEACE

by Hero of the Soviet Union, Admiral of the
Fleet of the Soviet Union S. G. Gorshkov

The Building of the Navy (1928--1941). The First World War did [14* not resolve the contradictions which had been engendered. Even during the course of the war, while having economic superiority over their rivals, the U.S. monopolists were laying plans to gain world supremacy. In this connection, the ruling circles of that day felt that the avenue to world supremacy lay in the strengthening of their naval might.

The struggle for superiority at sea has always occupied a significant place in the aggressive actions of U.S. foreign policy. However, this was displayed with particular force in the initial postwar years when American imperialism, having done its bloody business during the war, sharply expanded its activities in the countries of Latin America, Africa, and Asia. In striving to eliminate the opposition of its traditional competitors on the paths of imperialist expansion, the American leaders set themselves the primary goal of weakening the sea power of England. "Anglo-American 'cooperation' turned into a clear Anglo-American rivalry, expanding the prospects for a gigantic clash of forces," the Sixth Comintern Congress stated.*

* Kommunisticheskiy internatsional : dokumentakh, 1919--1923 (The Communist International in Documents, 1919--1923). Partizdat, 1933, p. 772).

The war of the diplomats for supremacy at sea was waged between all the imperialist powers at the Washington Conference of 1921--1922, the 1927 Geneva Naval Conference, and the London Conferences of 1930 and 1936. As a result of the prolonged struggle the USA achieved international recognition of the "parity" of its naval forces with the British forces, which meant that the USA and England emerged with equal rights in this area. However, Japan, Italy, and later also Germany, not having achieved by the diplomatic route the armament relationships which they desired and favorable positions for themselves in the world markets, continued to feverishly prepare for war. A regrouping had begun of the forces of the imperialist powers, and the contradictions between them continued to grow.

* Numbers in right margin indicate original pagination.

In the late 1920's and early 1930's the deepest economic crisis broke out in the capitalist countries, and the USA, England, France, Japan, and Germany were hardest hit.

As a result of the crisis the conflicts became even sharper between the imperialist countries, between the states which were the winners and losers in the First World War, and between the home countries and their colonies. At the same time the crisis evoked new enthusiasm in the class struggle. The revolutionary movement became particularly widespread in Germany, which was economically drained by the war, by the indemnities to England and France, and by the crisis which had begun. In order to preserve their power and not permit a further growth of the revolutionary movement the German bourgeoisie with the support of the bourgeoisie of other countries brought Hitler's Fascist Party to power.

The German Fascists marked their assumption of power, as we know, with the savage suppression of the working revolutionary movement, with the complete annihilation of bourgeois democratic freedoms, and with the unbridled militarization of the country and its economy. The foreign policy also took on a clearly anti-democratic aggressive character: Germany withdrew from the League of Nations, demanded a review of the borders of the European states for her own advantage, and overtly prepared for this redivision by means of arms.

One of the points of the military program of Hitler's Germany was the rapid restoration of a powerful Navy, which was rather successfully carried out under the principle of "cruisers instead of butter." Thus, in March 1935 the Germans began the construction of battleships, cruisers, and submarines. At the same time Hitler's diplomats initiated talks in [15 London to lift the restrictions on naval armaments which had been laid down by the Treaty of Versailles. In the summer of the same year an Anglo-German treaty was signed under which Germany was permitted to have a naval fleet with a total tonnage of up to 35% of the tonnage of the British Navy; in this case the submarine tonnage was limited to 45% of the tonnage of the British submarine fleet, however, under "special circumstances" it could be equal to it (the preparation by Germany for a war against the Soviet Union implied "special circumstances.") In connection with this, the English press wrote that "Great Britain, having herself experienced the threat of a naval weapon in the war period, is agreeing that the very same weapon will again appear in European waters right under her nose."*

* The Times, June 19, 1935.

Such an unceremonious violation of the Versailles Treaty was the consequence of the blind hate of imperialism toward the USSR and the belief in the fact that Fascist Germany with a weapon thrust into her hands would use it only to destroy the first and only Socialist state on earth at that time.

The conclusion of the Anglo-German naval agreement marked the beginning of the Munich Policy of the Western powers in Europe, aided the Hitler leadership to finally cross out all of the other restrictions of the Versailles Treaty, and was the stimulus for an open naval armaments race.

In 1937 a new economic crisis broke out, hitting primarily the USA, England, and France (it touched Germany, Italy, and Japan only slightly because their economies were supported by military contracts). The battle for commodity markets, sources of raw materials, and spheres of capital investment heated up with new force among the imperialist powers. The threat of an armed attack by international imperialism on the Soviet Union also increased. The policy of the Western powers attested to this. Thus, the ruling circles of France assumed that Hitler's aggressive operations in the East would weaken Germany, and this would facilitate the establishment of French supremacy in Europe. The US imperialists, in rewarding the aggressive intentions of Germany, believed that this would aid their policy of affirming world supremacy. Thus, the American "isolationists" and the European "peacemakers" essentially conducted the very same policy--a policy of the aggressive aspirations of Hitler Germany against the USSR.

This is also attested to by the agreement in November 1937 of the British government's representative Halifax with Hitler concerning the creation of an Anglo-German-French alliance, and also the conducting of a secret conference on the capturing of the commodity markets in the USSR and China called at the same time by the financial circles of Germany and the USA.

In conducting planned preparation for war, Fascist Germany strengthened its military might on land, at sea, and in the air. She not only re-established her main bases on the Baltic and the North Seas, but also built new ones. Ship construction was accelerated. Thus, in 1936 two 35,000-ton battleships, a 19,250-ton aircraft carrier, six 1811-ton destroyers, and eight submarines were laid down, and in 1937 warships of an equal total tonnage were laid down. It was assumed that by 1939 at those rates of construction Germany would fully restore her fleet. In 1938, Hitler demanded parity for his submarine fleet with that of the British. In 1939 the Navy of Fascist Germany numbered four battleships, 11 cruisers, 37 destroyers, 5 submarines, and two battleships, two aircraft carriers, four cruisers, and 16 destroyers, and eight submarines were under construction. The tonnage of Germany's merchant marine, which was the reserve of the Navy, was about 4.5 million tons at that time.

Thus, the center for the outbreak of a new world war was formed in the West, in the center of Europe.

A second center for the outbreak of a new world war was formed in the East. The imperialists of Japan, seeing that the European powers and the USA were busy with their own domestic circumstances brought on

by the economic crisis, decided to better their position by the armed [16 seizure of Northern China, and later of the Soviet Far East. In order to ensure themselves freedom of action, imperialist Japan, like Fascist Germany, withdrew from the League of Nations.

In preparing for aggressive operations Japan strengthened and expanded her system of naval bases at which the naval fleet, which was under intensive construction, was supposed to be based. By 1939 it had ten battleships, ten aircraft carriers, 35 cruisers, 106 destroyers, and 58 submarines. In addition, one carrier, two cruisers, eight destroyers, and eight submarines were under construction. The merchant fleet tonnage (counting ships larger than 1000 tons) was about five million tons.

Quite naturally our Party and government could not overlook these facts, and, while continuing to follow a continual policy of peace, they took measures to strengthen the defensive capability of the Soviet Union.

In order to protect herself from the aggression of such powerful capitalist powers as Germany and Japan, who were putting their entire economies, science, and technology at the service of their militaristic aims, the Soviet Union needed powerful armed forces equipped with the latest weaponry and combat equipment. And the Soviet people did everything possible to have such Armed Forces. In this period aviation was furiously developed, armored troops were created, and the mobility of the infantry and their firepower were increased.

Since Japan was a major naval power, Germany devoted particular attention to the restoration of a strong fleet, and England, the USA, France and Italy, possessing large naval forces, did not drop the thought of destroying the Soviet state, since to protect its maritime borders it was in need of a fully modern powerful Navy having a sufficient amount of all types of naval forces and all ship types in its inventory.

However, at the end of the 1920's our Navy consisted of combatants, batteries, and bases restored after the First World War and the Civil War, and reconditioned in the postwar period.

A significant event in the history of the Navy was the decisions of the expanded sessions of the USSR Revolutionary Military Council in May 1928 which defined the missions and the overall trend of development of the naval forces and which served as the basis for developing a naval ship construction program in the first Five Year Plan. The decisions said: "In developing the Navy we shall strive toward uniting the surface and submarine fleets, coastal and mined positional defenses, and naval aviation appropriate to the character of the combat operations to be conducted in our naval theaters in the situation of a probable war."* In

* Central State Archives of the Navy, Photo 1483, List 1, File 80, pp. 23-24.

other words, already in those years the principle of creating a Fleet consisting of harmoniously developed diverse forces had been affirmed.

The very same, but even more vividly expressed trend in the development of the Fleet was also retained in the naval shipbuilding plan for the Second Five Year Plan. As the basis of the new plan the requirement was made that construction would be primarily and mainly of a submarine fleet and heavy aircraft possessing strong maneuvering capabilities.* [17]

* Ibid, Photo 1483, List 1, File 201, pp. 1-2.

The character of naval construction in that period was determined by the missions confronting it, views of the capabilities of its combat employment, and the capabilities of industry and the achievements of science and technology both at home and abroad. In this connection, the experience of past wars and also the trend in the development of naval forces of foreign states were taken into account.

The Eighth Party Congress, based on the developing international situation and the need to defend the country under the actual historical conditions, made the wise decision with respect to the need of the Soviet Union to have a mighty sea and oceanic Fleet, corresponding to its interests. The naval forces existing at that time did not correspond to those needs. It was essential to create such a Fleet in a short time. And the country proceeded with its creation.

The industrialization of the country, the collectivization of agriculture, the liquidation of the exploiter classes, and the cultural revolution implemented by the Soviet people in the years of the initial five year plans under the Party's leadership permitted a sharp increase in the economic might of the Soviet Union. It was precisely in this period that the automotive, aviation, electrical engineering, and defense industries were created, and new shipbuilding yards were redesigned and built, thereby providing the materiel base for the construction of a new Fleet.

As early as 5 March 1927 the first DEKABRIST-class Soviet submarines were laid down in the enterprises of the shipbuilding industry. In 1930--1934 the LENINETS-class minelaying submarine, the SHCHUKA- and S-class medium submarines, and the small MALYUTKA-class submarines were initially turned out by industry. Soon construction was begun on the K-class ocean-going submarines. By 1 September 1939 the Soviet Navy had 165 submarines. The Soviet submarines were intended to operate both in coastal areas as well as on the high seas and were distinguished by their high performance characteristics. Thus, our Navy by the outbreak of the Great Patriotic War had become the possessor of the most powerful submarine forces in the world.

The creation of the naval surface forces was begun with the completion of cruisers which had been laid down as early as the First World [18]

War years. At the end of the 1920's and in the early 1930's the Black Sea Fleet was expanded with the cruisers CHERVONA UKRAINA and KRASNYY KAVKAZ. Later the construction of new surface ships of various types was expanded. Initially stress was put on PT-boats, escort ships, and destroyers, and later on light cruisers. In the first two five year plans the shipbuilders gave the fleet 106 surface ships: four cruisers, seven destroyer leaders, 30 destroyers, 18 escort ships, 38 minesweepers, one minelayer, and eight river monitors.

In 1938 with the adoption of the resolution on the construction of a large sea and oceanic Fleet, major surface ships were acknowledged to be its nucleus, although the interaction of various types of naval forces remained the main condition for the successful execution of missions. The shipbuilding program developed in accordance with this was weighted toward battleships and heavy cruisers, which were superior in quality to similar foreign ships. The change in views on the role of major surface ships took place under the influence of the fact that all the sea powers continued to feverishly build them, considering them to be the foundation of the fleet.

In 1938--1940 the laying down of the first of the SOVETSKIY SOYUZ [SOVIET UNION] class Soviet battleships, the KRONSHADT-class heavy cruisers, and the CHAPAYEV-class cruisers took place. By the outbreak of the war there were 219 ships in various stages of construction in the yards, including three battleships, two heavy cruisers, ten cruisers, 45 destroyers, and 91 submarines.

Naval aviation was also expanded. However, it did not have special naval aircraft and therefore was equipped with aircraft designed for the other branches of the Armed Forces. [While] effective for operations against land targets, they were poorly suited for carrying out combat missions at sea. Thus, due to the low speeds, short flight range, and small load capacity, the naval attack aviation was unable to successfully carry sufficient torpedoes against warships at sea which had been detected at long ranges from the airfields. It is true that when the Navy received the DB-3 (IL-4) aircraft that this deficiency of the attack naval aviation was partially eliminated. Due to the short operating range, weak armament, and short endurance naval fighter aviation was not in condition to reliably cover forces at sea even at relatively short distances from shore. This considerably limited the employment of major fleet surface forces in zones accessible to hostile aircraft.

The power of our coastal defense increased considerably: its equipment was upgraded, and areas of combat employment were expanded. In 1940 alone the number of coastal artillery batteries grew by almost 45%, and the number of AA batteries doubled.

TABLE
Performance Data of Prewar Soviet and U.S. Ships.

Performance Data	Battleships		Heavy cruisers		Light cruisers		Destroyers		Escort ships	
	SOVIET UNION 1939	IOWA 1939	KRON - SHTADT 1939	ALASKA 1939	KIROV 1939	BROOK-LYN 1936	OGNEVOY 1939	FLETCHER 1939	YASTREB 1939	TACOMA 1939
Displacement, t full standard	65 150 59 150	59 000 45 000	39 360 35 240	32 000 27 500	11 500 9 000	11 500 9 700	2 956 2 240	2 750 2 050	1 050 983	1 100
Propulsion power, hp	33 000	203 000	231 000	150 000	110 000	160 000	54 000	60 000	.	5 500
Max. speed, kn	29	30	33	30	35	32.5	37.1	34	31	33
Guns, mm	IX-406 XII-152 VIII-100 XXXII-37 VIII-12.7	IX-406 XX-127 LXXX-40 XLVIII-20	IX-305 VIII-152 VIII-100 XXIV-37 VIII-12.7	IX-203 XII-127 .-10 .-10	IX-150 VI-160 XVI-57	XV-152 VIII-127 IV-40	IV-130 II-76.2 III-37 IV-12.7 .	V-127 IV-40 IV-20	III-65 IV-37 III-12.7	III-70 .-40 .-20
Torpedoes	--	--	.	--	IX-3-503	.	IX-3-503	IX-3-333	IX-3-450	
Mines	--	--	--	--	.	.	(A)	(B)	.	(C)
Aircraft	(D)	(E)	(F)	(G)	(H)	(I)				

(A) Depth charges, 96 mines; (B) Depth charges; (C) Depth charges; (D) 1 catapult, 4 aircraft;
(E) 2 catapults, 4 aircraft; (F) 1 catapult, 4 aircraft; (G) 2 catapults, 2 aircraft; (H) 1 catapult,
2 depth charges; (I) 2 catapults, 4 aircraft.

In the years of the prewar five year plans, naval scientific-technical thought made a great contribution to the creation of new, and the upgrading of existing models of mine, torpedo, and especially gunnery armament. In these same years the first radar sets were created in our Fleet, models of infrared equipment made their appearance, subunits of remote controlled torpedo boats were formed, the first types of air-cushion vehicles were tested, and the employment of fighter-carrying aircraft was developed which operated successfully at the outbreak of the Great Patriotic War. All of this considerably increased the capabilities of the Navy. [20]

Thus, in line with the development of the Socialist economy the defensive might of our state was strengthened and the power of the Soviet Navy as an integral part of the country's Armed Forces was restored.

The development of a Navy, which is a most difficult process in which outmoded weapons systems are replaced by new ones corresponding to the fullest measure to the current level of development of equipment and to the requirements of naval warfare, is the final result of vast scientific work determining the optimal variants for decisions of the most major strategic, strategic-tactical, and technical problems. The solution of these problems permits the most intricate combining in each ship of technical devices, systems, and complexes made up of the peak in engineering thought based on the very latest achievements in science, technology, and production and the concentrating of the maximal combat capabilities with the most economical "expenditure" of weights, dimensions, and displacements.

However, the construction of a Fleet is not just the building of combatants and batteries and the creation of new models of naval equipment. The construction of a Fleet is also greater organizational measures based on principles, and the further development of the naval art and the training of specialist cadres.

The great importance attached by the Navy to the armed defense of the country was expressed organizationally in the formation in December 1937 of the People's Commissariat of the Navy.

The formation of the People's Commissariat of the Navy permitted concentrating the leadership of all of the measures connected with the construction of a large ocean-going Fleet in a few hands.

One of the organizational measures was the creation in 1932 of the Pacific Fleet and the creation in 1933 of the Northern Fleet. After the entry in 1940 of Estonia, Latvia, Lithuania, and Bessarabia into the USSR, the Baltic and Black Sea Fleets considerably expanded their basing areas: the former emerged from the eastern part of the Gulf of Finland to the expanses of the Baltic Sea, and the latter to the mouth of the Danube where the Danube Flotilla was created. Major formations of forces, e.g., brigades and squadrons, made their appearance in all of the Fleets.

At the same time as the warship construction and the organizational measures, a scientific quest was being made for more effective methods of combat employment of naval forces and of their weaponry in battle with a powerful enemy. In other words, the development of the naval art took place in accordance with the actual materiel-technical base of the Fleet.

The international situation and the overall missions of the Armed Forces stemming from it determined the Navy missions: cooperation with the Red Army, repulsing enemy operations against our coast from the direction of the sea, the creation of favorable conditions for operations by own forces in a naval theater (not just in the littoral area, but throughout the entire depth of the operation), and action against the enemy's economy by severing his sea and ocean communications. [21]

Taking into account the state of Soviet and foreign fleets and the immediate prospects for their development, our naval science came to the conclusion that the outcome of the war would be decided on land, and therefore the Navy would have to carry out missions in the war stemming from the missions of the ground forces. In addition, our naval thought did not rule out the fact that in some stages of the war the Navy could also carry out the main mission in one theater or another.

Questions concerning the theory of the naval art were worked out in accordance with the new missions of the Navy in the academies and scientific research institutes. This creative process took place amid a situation of a sharp clash of opinions between proponents of offensive and defensive views on the role and employment of naval forces in the forthcoming war. The former were still under the influence of the "small war" theory, which was correct in their day, while the latter, believing that our Fleet had already become capable of conducting combat operations beyond the limits our own coastal waters held to the "control of the sea" theory. However, the interpretation of the term "control of the sea" was somewhat different than that held in the West. Thus, in a Naval Academy course of lectures of that period it was stated: "To achieve superiority of forces over the enemy in the main sector and to pin him down in the secondary sectors at the time of the operation means to achieve control of the sea in a theater or a sector of a theater, i.e., to create such a situation that the enemy will be paralyzed or constrained in his operations, or weakened and thereby hampered from interfering with our execution of a given operation or in our execution of our own operational mission."* It was precisely this interpretation of sea control which was the basis of the employment of naval forces in naval warfare.

* Captain 2nd Rank V. A. Belli. Theoretical Principles of Conducting Operations. Synopses-Theses. Naval Academy, 1938.

Naval combat training in the prewar years was directed toward the development of the tactics of a naval battle primarily in own favorably equipped areas. The main attention was focussed on the organization of a joint concentrated attack of surface ships, PT-boats, aircraft, and

submarines against groupings of hostile surface ships in the coastal zone of a sea and against our mine and gunnery positions being built in the narrows and at the approaches to the naval bases. In addition, a great deal of attention was also attached to so called hit-and-run operations (in the form of strikes against ports, naval bases, and groups of ships in enemy coastal waters) carried out by surface forces independently or in concert with the Air Force. [22

A great achievement of Soviet naval science was the development in the 1930's of a new chapter in naval art--the theory of the operational employment of Fleet forces. It correctly analyzed the role of various types of naval forces in armed combat, and, in particular, pointed out that in actual operations the role and significance of one type of naval force or another or ship type depends on the missions being executed, the relative strength of the forces, and the military geographical conditions of the theater.

In contrast to the bourgeois naval science, Soviet naval science correctly determined the role of aviation in naval warfare. And although in the official documents governing the employment of the Navy (including also those published in 1940), aviation was relegated to the role of one of the main means of reconnaissance and support, it was clearly stressed in the speeches of the Navy leadership, in the pages of the press, and in the courses for the students at the Naval Academy that no naval operation is conceivable without air forces.

Basing itself on Soviet experience in landing landing forces, Soviet naval art in the 1930's developed for the first time in history a theory of amphibious landing operations which was checked in the course of combat training.

It should be noted that in its zeal to somehow justify the shameful failure of the Dardanelles operation of 1915 by objective reasons and to save the faltering prestige of the "Mistress of the Seas," the British Admiralty went so far that it not only convinced others but also itself of the impossibility of landing amphibious forces. As a result, as one of the most important conclusions from the experience of the First World War the naval theoreticians of the Western countries acknowledged the complete lack of a future for joint operations of Fleets with ground forces, and especially one of such diversity as the landing of a landing force. This conclusion was contrary to the combat experience of the Russian Fleet which successfully landed a landing force at Lazistan [Rize, Turkey] and also with the wealth of experience of Soviet naval forces in the struggle with the White Guards and interventionists on the Civil War fronts. It was precisely due to the ignoring of this experience and due to the inability to discover trends in the development of the form and nature of armed combat that at the outbreak of the War not one of the Navies of the Western powers had a developed theory for amphibious operations and not one had specially constructed landing ships and troop units trained for these operations.

From what has been said it is evident that Soviet naval art in the prewar years took a giant step forward and surpassed bourgeois naval art with respect to a series of points. Prior to the outbreak of the Great Patriotic War it represented a structured and completely modern (for that day) system of scientific views of the strategic and tactical employment of naval forces for the execution of the missions facing them. In this connection, in our naval art of those years the point of view predeominated of employing naval forces for defensive purposes, although the missions and strategic and tactical plans were carried out strictly by offensive methods. The employment, however, of submarines, including also cruising submarines having a very long operational range, was limited by the framework of the tactical missions executed by them which were primarily in nearby areas of the theaters. It was precisely because of this that the question of conducting combat operations in the ocean was not even raised, although the capability for this already was there.

Unfortunately this was not the only minus in the prewar construction of our Navy. Thus, the well developed theory for conducting amphibious operations did not receive the needed material or organizational implementation for a series of reasons (mainly of an economic nature): by the outbreak of the war not one of our Fleets had a single specially constructed landing ship. The fleets also did not have the required number of surface gunnery ships to support the landing of a landing force because it was believed that this would be done by gunboats, cruisers, and destroyers. However, the cruisers and destroyers were trained mainly to combat enemy surface ships and firing at shore targets was a secondary mission, and many slow-running gunboats armed with one to three medium-caliber guns were obsolete. All of this limited the Navy's capabilities to carry out missions in concert with ground troops and made it difficult to conduct landing operations in far-off areas of a theater. [23

Unfortunately questions of joint operations between the branches of the Armed Forces were also not given the requisite attention. One can see in this one display of the underestimation by some of the leaders of the Armed forces of the role the Navy in the forthcoming war. However, precisely because of this reason no unity of views was achieved on the principal questions of joint operations of the naval forces and the ground troops in the coastal areas. Thus, as a result, the tactical cooperation of ships and army units was worked out only in general frameworks, and the amphibious training of the ground troops was relegated to a secondary position.

The latest guiding documents--regulations, directives, rules, and methodologies--were developed and introduced in the prewar years in accordance with the latest missions of the Navy, methods of executing them, and the materiel base. They were all imbued with a spirit of attack in any situation. The requirement for maintaining a high level of combat readiness for active offensive operations at sea, in the air, in coastal waters, off of enemy bases, and against sea communications was important in these documents. The documents recommended executing missions with

diverse interacting forces, marshalling of forces for attacks, and a fuller utilization of firepower and mobility by the groupings participating in the battle.

The increase in the naval ship inventory and the number of units required training a large contingent of naval specialists and above all command cadres. In connection with this, in the late 1930's the network of naval training institutions was considerably expanded while the schools training command personnel for the Navy were the first in the Armed Forces to be converted to higher training institutions. Thanks to this the Fleet was expanded by remarkable officers having sound general and special training prior to the Great Patriotic War.

By the outbreak of the Great Patriotic War, our Navy had four strategic formations: the Northern, Baltic, Black Sea, and Pacific Fleets, and also the Danube, Caspian, Pinsk, and Amur Flotillas. The composition of the Navy included three battleships, seven light cruisers, 66 destroyers and destroyer leaders, 22 escort ships, 80 minesweepers, 269 torpedo boats, 218 submarines, 2529 aircraft of all types, and 260 coastal artillery batteries, which permitted carrying out the tasks of coastal defense and of supporting the Red Army. Although distributed throughout the individual theaters, the Navy as a whole still represented a considerable force. With respect to ship inventory and total displacement it was about sixth or seventh in the world.

However, the insufficient number of ASW ships, minesweepers, and auxiliaries, and the absence of specially built landing craft considerably reduced Fleet capabilities with respect to maintaining favorable conditions in the theaters and made the execution of certain missions difficult. It cannot be considered normal that not one of the Fleets had naval infantry, that the air defense forces and equipment were weak, and that the reserves of influence mines and sweeps turned out to be small.

Yet despite the series of deficiencies in construction and training, the Navy as a whole on the eve of the war possessed a high degree of combat readiness. This was one of the most important results of the work of our Party which directed the Navy personnel to maintain every ship and unit in constant combat readiness. The Navymen educated by the Communist Party and Komsomol were distinguished by exceptionally [24] high morale and combat qualities. Their fleet friendship, faithfulness to their military duty and to their remarkable revolutionary and combat traditions, and their fidelity to the Motherland ensured a constant high state of combat readiness and the combat capability of all of our Fleets.

This to a great degree fostered the introduction of a new system of combat training which permitted the working out of fleet force and unit training missions the year round and a reduction in the length of preparation for large all-fleet exercises (whereas earlier such exer-

cises were normally conducted in the fall, in 1941 the Black Sea and Northern Fleets were able to complete them in the summer before the outbreak of war).

An important moment was the new organization of the transfer of our Fleets to a higher state of combat readiness, which was worked out and checked even before the outbreak of the Great Patriotic War. It was precisely owing to this system that the Fleets were brought to full combat readiness in time and successfully repulsed the first surprise attacks of Fascist Germany against our bases on the night of 22 June 1941 and avoided many severe consequences.

It follows from what has been said that the constant concern of the Party and government for the security of the maritime borders of the Motherland permitted the creation in a short time of an essentially new, fully modern Navy capable of executing the missions with which it was charged.

By the outbreak of the Great Patriotic War of 1941--1945 the Soviet Navy represented an imposing force which our enemies were forced to take into account. It was completely prepared to defend the state interests of the USSR in the contiguous theaters, to repulse the attacks of enemy fleets, and was able to operate in concert with major ground force groupings in the littoral areas and reliably cover their flanks and rear. Moreover, our Navy was capable of undertaking active operations against the enemy's sea communications and against coastal groupings of his ground forces.

The fact of the creation of a rather strong Navy in our country did not go unnoticed by the naval powers as evidenced by Britain's invitation to the Soviet Union in 1936 to take part in the work of the London naval arms limitation conference. The Soviet government, true to its peace-loving policy, entered into the negotiations with Great Britain in order to check the naval arms race to some degree. However, Moscow laid down the condition at London that Germany also be obliged to limit armaments. Great Britain was forced to sign such an agreement with Germany. However, the accelerating preparation of the imperialist powers for a new world war made such an agreement unrealistic. The London naval arms limitation talks turned out to be only the final break of the imperialist powers prior to the outbreak of the Second World War and showed that the imperialist powers were aligning themselves not for the purpose of limiting naval armaments, but to wage the forthcoming war and to seek allies for themselves for a future war.

The creation of the Soviet Navy attested to the readiness of the Soviet Union to protect its freedom and independence from encroachments by aggressors in all of the maritime theaters contiguous to it.

(To be continued).

Photograph captions: p. 16: An SH-4-class torpedo boat.
p. 17: A LENINETS-class minelaying submarine.
p. 18: The Soviet cruiser KIROV.
p. 20: A SHCHUKA-class submarine.
p. 21: A GORDYY-class destroyer.

WITH THE SHIPS, UNITS, AND FORCES OF THE FLEET

This is the busy season in the Fleets. The summer combat training period has reached its apogee. Aboard the ships and in the units the competition for a worthy welcome for the 50th anniversary of the formation of the Soviet Union is acquiring ever greater dimensions. In fulfilling their obligations, the fighting men are steadily perfecting their sea, air, and field training, and are learning what is essential in warfare.

[25

Red Banner Northern Fleet

The Northern Fleet Military Council heard and discussed reports "On the preparation for the 50th anniversary of the formation of the USSR" which were made by the Chief of Staff of a submarine force and the chief of the political department of the Fleet rear services. The Military Council noted that the competition for a worthy welcome for the 50th anniversary of the USSR has had a positive effect on the state of affairs in the submarine force and in the Fleet rear services. In addition, errors were pointed out in the work of the commanding officers, staffs, and Party and Komsomol organizations. The Military Council made it incumbent upon them to engage more concretely in questions of Socialist competition on long cruises, steadily introduce Leninist principles of competition, and to improve propaganda on leading experience.

* * *

General quarters for training was sounded. The radar antennas came alive, the engines were started, and the patrol boat put out from port.... The search for the "enemy" had begun. Within a short time Captain 3rd Rank V. Magera received a target acquisition report.

"Missile attack..."

Several seconds later the missiles rushed toward the "enemy." The target was hit.

The guided-missile patrol boat of V. Magera rightly bears the title of one of the best in the unit. The crew, the holder of a Komsomol Central Committee pennant, is successfully fulfilling their Socialist obligations in honor of the 50th anniversary of the formation of the USSR.

* * *

Officer Averin, the commanding officer of a ship, is an outstanding methods specialist. Here all the group leaders of specialty training classes are given independent training notebooks in which the assignment for the month is indicated. The night before each class the officer holds a methods briefing, and checks the readiness of the leaders. He totals up the results of the classes himself. Seminars and illustrative practical training sessions are held with the crew in which the officers, warrant officers, and petty officers systematically [26 share experience in training subordinates and learn how best to conduct one class or another.

* * *

In the combat glory room of the unit where officer V. Popov serves there are many prizes which have been won by the aviators in military work. Recently authorization for one more honorary trophy was received: the USSR Navy prize for the best rationalizing work, equipment of the training facilities, and scientific organization of labor.

Red Banner Pacific Fleet

When the missile-carrying aircraft piloted by Senior Lieutenant Yu. Khalin approached its home airfield the weather sharply deteriorated. This was the first solo flight for the young pilot in difficult weather conditions. The flight leader and the subunit commander attentively followed the pilot's actions. The officers knew Khalin well and the level of his training. "You have permission to land," the leader said quietly into the microphone and soon the heavy craft landed smoothly on the runway.

Senior Lieutenant Yu. Khalin, like his subordinates, is still young. However, each time he thoughtfully prepares himself for a flight, while steadily demanding the same of his crew. And this yields positive results. In carrying out a regular mission in the air, the aviators detected a target in the ocean at the maximum range and delivered an irrepulsable attack against it.

* * *

The cultural life in this far-off aviation garrison is the key. Here an amateur theater has been built and is working creatively (V. Popov is the director). For the 50th anniversary of the formation of the USSR its collective is preparing a new spectacle "The Last Meeting," which tells about the friendship of fighting men of different nationalities. Senior Lieutenant B. Khityayev and the wife of serviceman V. Shabel'nik and others have the main roles. The university of culture is also popular here. It has a very rich record library, compiled by Major Ye. Komarov. A children's ballet studio is in operation in the garrison. Its organizer and leader is the wife of officer T. Shushpanov. The concerts of the young artists enjoy invariable success.

* * *

This subunit of minesweepers commanded by Captain 2nd Rank Malyy for three consecutive years has won the Navy Prize in tactical and firing training. This success is not accidental. The CO and the party organization devote a great deal of attention to questions of combat training. More than 80% here are otlichniki* and class specialists.**

* Otlichnik - One who has been declared outstanding by his CO in combat and political training.

** Class specialists - An officer or enlisted man who has passed the Officer or EM proficiency test in his specialty. There are 3rd, 2nd, and 1st class specialists as well as master specialists.

The fighting men of the ships surpass all the regulation standards by a factor of two or three. The navymen demonstrated their high degree of special schooling and training in the last competitive sweep.

* * *

The torpedo firing training room equipped with various devices and a tube simulates the main control center of a ship. Captain-Lieutenant Yu. Timokhin who is steadily mastering the art of conducting a modern battle under the leadership of his experienced commander often visits here. And recently the officer had to pass a test of his combat maturity. The Captain-Lieutenant commanded the ship during the search and destruction of the "enemy." Timokhin's attack was outstanding: the torpedo ran exactly under the target.

Twice Honored Red Banner Baltic Fleet.

[27

The outstanding crew of the aircraft where officer N. Modeyev is the commander has a good reputation in the Baltic Fleet. Not long ago the aviators once again affirmed their title of masters of military affairs: and an "enemy" ship was destroyed by a direct missile hit. This is the crew's gift to the USSR Air Force Day and another contribution to fulfilling Socialist obligations in honor of the 50th anniversary of the formation of the USSR.

* * *

The ship was maneuvering. A gunnery firing was ahead. Particular tension reigned at the action stations directly participating in the execution of this mission. Even the fire control officer Yu. Makarov was excited: the order to open fire could come at any second.

The target was spotted. The salvos thundered. The firing was carried out with an "outstanding" grade. For skillful education of subordinates, successes in service, and high mastery the CinC Navy, Admiral of the Fleet of the Soviet Union S. G. Gorshkov, awarded Yu. Makarov a valuable gift.

* * *

In the Tallinn Officers Club a meeting was held of the victors in the first stage of the Socialist competition in honor of the 50th anniversary of the formation of the USSR and the Leninist Examination "Decisions of the 24th Party Congress--Brought to Life." Representatives of many nationalities of our Motherland reported to the Party and the Komsomol Central Committee on the successes achieved in the course of the All-Union Leninist Examination. The participants in the meeting made an appeal to the Komsomol members and the youth of the garrison.

* * *

What should a Fleet officer be? A discussion of this was held at a meeting of the Komsomol active members of the Kaliningrad Higher Naval School. The speaker, Head of the School Rear Admiral V. Pili-penko, told of the requirements which are raised for training future officers. It is essential already in one's cadet days to develop in oneself an ideological conviction, high discipline, a command will, and the ability to train and educate navymen. The active members exchanged experience on their work, and noted ways of eliminating uncovered deficiencies.

Red Banner Black Sea Fleet

The guided-missile helicopter cruiser LENINGRAD has returned from a long cruise in the Mediterranean Sea and the Atlantic Ocean. All firing and ship-type missions were successfully executed. The ship's personnel displayed a high degree of nautical training, courage and toughness, and ideological and political maturity on this difficult and responsible cruise. Captain 3rd Rank-Engineer K. Kudelya, Captain-Lieutenants G. Kondakov and G. Mel'nik, Lieutenant-Engineer I. Obukhov, aviators Senior Lieutenants V. Chukronov and N. Shevchenko, and Lieutenant V. Febenchukov particularly distinguished themselves.

* * *

Communist Captain-Lieutenant O. Akramov was just recently appointed commanding officer of a guided-missile patrol boat, but he has already been able to show his subordinates that he is a good organizer and educator. Thus, in carrying out a missile firing against sea targets the personnel hit the "enemy" accurately. The patrol boat's crew

is among the leaders in the Socialist competition for a worthy welcome for the 50th anniversary of the formation of the USSR.

* * *

Short training sessions were held of Fleet ship, unit, and force propagandists, chiefs of cultural educational institutions, and editors of high circulation newspapers. The participants discussed a report by the Deputy Chief of the Black Sea Fleet Political Directorate Captain 1st Rank V. Khariton on the state of ideological work in carrying out the decisions of the 24th CPSU Congress and on tasks for improving the ideological political education of the fighting men in light of the requirements of the CPSU Central Committee resolution on the preparation for the 50th anniversary of the formation of the Soviet state. Communists I. Rudnev, F. Grigor'yevskiy, B. Fedotov, N. Shalagin and others participated in the discussion.

* * *

A group of teachers of the P. S. Nakhimov Black Sea Higher Naval School under the leadership of the Head of the School, Rear Admiral S. Sokolan, has completed a work on the subject "The organization of military labor of a young officer aboard ship." Its purpose is to reduce the time spent on the development of the young officer. The work consists of a "Calendar plan for the development of the young officer" and a "Set of measures concerning the basic duties of a group (department) commander."

The calendar plan includes measures which an officer arriving aboard ship must fulfill within six months. All measures are broken down into stages with an indication of the time they should be accomplished.

The set of measures represents a list of basic duties of a group (department) commander which are distributed according to the time of operation and execution (daily, weekly, etc.) in accordance with the requirements of the Armed Forces Regulations and other appropriate documents.

It is organically related to the calendar plan and permits a reduction in the period of development of the young officer aboard ship due to the scientific organization of labor.

The work has received favorable comments in the Fleets.

Red Banner Caspian Flotilla

Baku received an official visit from navymen of the Iranian naval forces who arrived aboard the minesweeper SHAHROKH under the flag of the Commander of the Phalavi Naval Base, Rear Admiral S. Anushirvani.

The guests were introduced to the history and combat and revolutionary traditions of the city and republic, with the successes in industry and culture, and visited the S. M. Kirov Caspian Higher Naval Red Banner School.

A reception was held in honor of the Iranian navymen at which Deputy Chairman of the Azerbaydzhan SSR council of Ministers K. Guseynov told of the development of the republic in the years of Soviet rule and of its prospects.

* * *

In Makhachkala a holiday was held of the youth of the Caspian Sea cities and Caspian Fleet navymen devoted to the 50th anniversary of the formation of the USSR. Young workers in the yards and factories construction men, production leaders, and fighting men of the Caspian told of their work, and exchanged working reports on the progress in fulfilling the Socialist obligations assumed in honor of the jubilee of the Socialist state.

The torch-light procession went through the streets of the city. Amateur concerts, mass parades, and sporting events were held.

The senior intern in the surgical department of the hospital Colonel Senchuk is famous in the Flotilla as one of the most experienced doctors.

Numerous government decorations attest to his bravery and courage displayed in the war years. Now the badge "Outstanding Worker of the USSR Public Health Service" has been given to this tireless worker, to this efficient and sympathetic man.

The Naval Academy

The Commander in Chief of the Chilean naval forces, Admiral Rauol Montero Cornejo, and a military delegation from the Republic of Peru headed by Chairman of the Joint Armed Forces Command Lieutenant General of Aviation Eduardo Montero Rojas visited the Naval Academy. The guests saw the training laboratories, and were acquainted with the history of the Naval Academy and the organization of the training process. They noted that the great experience of the teachers and the outstanding equipment of the laboratories permits the training of highly qualified career personnel for the Navy.

Photograph caption, p. 25: The head of an outstanding engineering department of a submarine Captain-Lieutenant R. Akvenov, Warrant Officer B. Prokof'yev, and Senior Seaman V. Ishelev on a cruise.

p. 26: First Lieutenant of a cruiser Senior Lieutenant L. Kibkalo handles his duties successfully. It is a clean and taut ship. He has repeatedly been given incentive awards by the CO for outstanding work.

p. 27: The crew of the small ASW ship commanded by 3rd Rank V. Yefimov carries out all missions with high grades. The ship bears the title of outstanding.

p. 28: Some leisure minutes on the deck of the guided missile cruiser GROZNY.

THE DEVELOPMENT OF SMALL COMBATANTS AND
METHODS OF THEIR EMPLOYMENT

by Hero of the Soviet Union
Admiral V. Alekseyev

Small combatants appeared for the first time during the Civil War in the USA (in 1864 the South's torpedo boat sunk the North's sloop-of-war HOUSATONIC), however, they were extensively employed in the Russo-Turkish War of 1877--1878 (at that time the Russian torpedo boats actively operated against Turkish major combatants). The appearance of this type of naval force became possible owing to the presence of steam engines and first the towed and spar mines [torpedoes], and later also self-propelled mines (i.e., torpedoes). [32]

The performance characteristics of the small combatants of that period predetermined the basic methods of employing them: night infiltration attacks independently (or in small groups) against enemy ships anchored in a roadstead. One of the initiators of the creation and employment of torpedo boats, Stepan Osipovich Makarov, wrote that "the steamship VELIKIY KNYAZ' KONSTANTIN with equipment for raising four steam patrol boats was designed to deliver these boats to any enemy port so that they could make a night torpedo attack and return to their own steamship before dawn."*

* S. O. Makarov. Rassuzhdeniya po voprosam morskoy taktiki (Discourses on questions of naval tactics), Voenmorizdat, 1942, p. 243.

At about this same time gunboats made their appearance which were designed to handle scouting and patrol work and to combat the enemy's torpedo boats, and also patrol boat-minelayers appeared which were designed to lay moored mines in areas where enemy ships were operating.

The successes achieved by the Russian small combatants resulted in the mass construction of them by the chief naval powers at the turn of the 20th century. Thus, in 1904 Russia had 83 of them: Italy, 59; Great Britain, 54; and Japan, about 60. The development of science and technology and also of the naval art brought about considerable changes in the performance characteristics of these small combatants: their displacement was increased 4 to 5 times, their speed, 5 to 6 times, and their seakeeping ability was twice as good.

In the Russo-Japanese War of 1904--1905 small combatants were rather widely used by both of the belligerents. However, due to the imperfection of the armament (e.g., torpedo range, 500--1000 m; speed, 16-20 knots; explosive charge, 60--80 kg), it was necessary to close to short ranges even with a stationary target. Therefore in order to achieve surprise and employ the armament effectively, major combatants were attacked by the small boats under limited visibility conditions (at night, in fog and rain).

The unimportance of the victories achieved by small combatants in the Russo-Japanese War reduced interest in them. However, the First World War of 1914--1918 again brought to life small combatants, which were aided by achievements in science and technology, permitting a sharp increase in the quality of their armament and the provision [33 of powerful (for that period) small internal combustion engines.

The small combatants at that time had a rather powerful armament for their size, but poor endurance, poor seakeeping ability, and poor habitability, and they had no built-in protection against enemy counteractions.

The basic reasons for the revival of small combatants in WW I in such countries as Great Britain, Germany, and Italy, were the uniqueness of the naval theaters, which increased the effectiveness of the use of small boats against large combatants (the rugged shoreline, the presence of archipelagoes, etc.), the possibility of the mass construction of relatively cheap combatant units in a short time, their suitability for movement to the areas of combat operations by almost all forms of transportation, the simplicity of training small boat personnel, and finally the capability of reliably destroying major combatants.

The interest in small combatants is attested to, for example, by the fact that at the end of 1916 Italy had 46 torpedo boats, and at the end of 1918 she had 199. During the war, all of the belligerent countries built a total of more than 1200 high-speed small combatants, of which more than 300 were PT boats.

In the First World War small combatants were employed mainly in small groups for independent operations. Only at the end of the war did they start to be used for operations in company with other naval forces. They participated in hit-and-run operations against enemy bases, patrolled off their own shores, searched for and destroyed submarines, convoyed merchantmen and combatants, and laid active minefields. As in the previous wars, the small combatants operated primarily under reduced visibility conditions (at night and in fog and rain) in coastal waters.

The victories gained by combatants in WW I were the main reason for the unfailing attention to this type of naval ship. However, in the period between the wars their construction was mainly limited to experimental models. The basic trends in the development of small combatants were an increase in their seakeeping and maneuvering qualities, an increase in cruising range and speed, an improvement in armament and also the equipping of them with more advanced means of observation and communication.

In building new classes of small boats designers ran up against the need to satisfy mutually exclusive requirements (e.g., increasing the power of the armament, seakeeping ability and cruising range, while at the same time increasing the speed and retaining the small dimensions). In order to get around this, the small combatants were built in two varieties: for operations in coastal areas (they possessed a high speed, but a short range and poor seakeeping ability) and for operations in distant and open areas (they had good seakeeping qualities, great endurance, but a lower speed). The former were built primarily in Finland and England, the latter in Germany and Italy.

With the outbreak of WW II small boat construction was expanded first with prewar designs, and later according to designs created during the course of the war taking into account the combat experience which had been gained.

During the war, PT boat tactics underwent considerable changes. Thus, whereas initially they operated independently, singly or in small groups, later they operated in groups in company with other naval forces (especially with air forces). With respect to form, their operations were very diverse: free hunting, interception, powerful penetrations, seizures, and attack when summoned by radio.

An increase in the range and running accuracy of torpedoes permitted attacks at ranges up to 20 cables. The installation of rather powerful gunnery armament, smoke equipment, and also combat support by other forces made it possible for PT boats to operate under any visibility conditions and not just in poor visibility.

Attacks were made by breaking through the enemy's convoy guard [34 under cover of smoke screens from one or several directions.

In the Northern Fleet attacks against the same convoy by two or three tactical groups of boats were extensively used. Aviation and groups of two to three boats equipped with radar were employed to search for the enemy and to vector the attack groups to him. An example of the concerted operations of our PT boats and the air force were their attacks in the Baltic against convoys and ships in the Irbe Straits, where in two and a half months in 1941 they sunk or damaged more than 20 Fascist combatants and transports.

Unclassified

SMALL COMBATANT ARMAMENT

[35

Subtype of patrol boat	Period				
	Russo-Turkish War	Russo-Japanese War	WW I	WW II	Postwar period
Torpedo	1-2 spar or towed mines or 1 torp.	1-2 torp, 1-2 37--42 mm can.	--	--	--
Gun boats	1-2 20--30 mm can.	1-2 37--42 mm can. 1-2 MG	1-2 30--45 mm can. 1-2 MG	1-2 45--100mm can. 1 30--37 mm auto. gun	1-2 40--114 mm can. 1-2 mortars
Minelayers	1-2 moored mines	2-4 moored mines	1-6 moored mines	2-12 moored or bottom mines	2-12 moored or bottom mines, 1-2 MG, 1 20--40 mm can.
Minesweepers	--	light contact sweep	light contact sweep, 1-2 MG	light contact & noncontact sweep, 1-2 MG	light con. & noncon. sweep, 1-2 MG, 1 20--40 mm can.
PT boats	--	--	1-2 torp. 1-2 MG	2-4 torp. 1-2 20--40 mm can 1-4 MG	2-6 torp. 1-4 20--57 mm can 1-2 MG
ASW	--	--	1-3 20--25 mm can 1-2 MG, 10-20 DC	1-3 20--45mm can, 1-4 MG 15-30 DC, DC launchers	1-2 DC launchers 2-4 ASW torp. 1-2 20--40 mm cannon
Guided missile boats	--	--	--	6-12 rocket projectiles 1-4 MG	2-4 cruise missiles 1 20--75 mm can. 1-6 MG

Reproduced from best available copy.

In the entire years of the Great Patriotic War the Soviet PT boats made 2656 sorties against communications, and 378 attacks, and sunk and damaged more than 250 combatants and auxiliaries. In this connection, of the PT boat sorties to disrupt the enemy's sea communications about 15% were in the Black Sea, about 30% were in the Baltic, and about 60% of the total number of combat sorties were in the North.

Torpedo boats were also extensively used in foreign navies. Thus, from 1939 through 1945 British boats launched 1326 torpedoes of which 318 hit the target.

In order to reduce the effectiveness of PT boat operations the belligerents used a strengthened guard for the targets of attack, used routes of movement for these targets beyond the range of the boats, employed attack aircraft and freely maneuvering groups of gunboats against the PT boats, etc. In addition, they tried to blockade the PT boats in their ports, and to attack their basing points (as, for example, prior to the landing at Normandy in 1944).

In the Second World War and the Great Patriotic War gunboats were also extensively used. They had high-speed and maneuvering features approaching those of the PT boats, but had a stronger gunnery armament installed in place of the torpedoes. Gunboats executed the missions of combatting the enemy's PT boats, supporting the operations of own PT boats, convoying transports, supporting minesweeping, etc. Gunboats were also brought in to participate in landing operations in which they were charged with protecting the landing ships from attacks by light forces of the enemy, landing the leading detachments on the enemy shore, and fire support of the landing units.

Small boat-submarine chasers were no less widely employed. The [35 equipping of them with the latest sonar detection instruments and destructive means permitted a considerable expansion of the "assortment" of means for searching for submarines and attacking them. As a rule, the attack against the detected submarine was prosecuted by "aimed" depth charging of it. Follow-up sorties of individual subchasers ensured repeated and prolonged actions against the submarine and eliminated a loss of contact with it. During the attack the boats laid a depth charge pattern, increasing the area and probability of target destruction (the American boats, for example, had up to 11 depth charges in a pattern).

In WW II and the Great Patriotic War small boat minelayers and minesweepers were employed on a wide scale. The former were employed for active mine laying off the enemy bases, in narrows, in exposed fairways, and on the courses of detected convoys. In this case not only the specially constructed small boats were used to lay mines, but also torpedo boats and gunboats outfitted for this purpose.

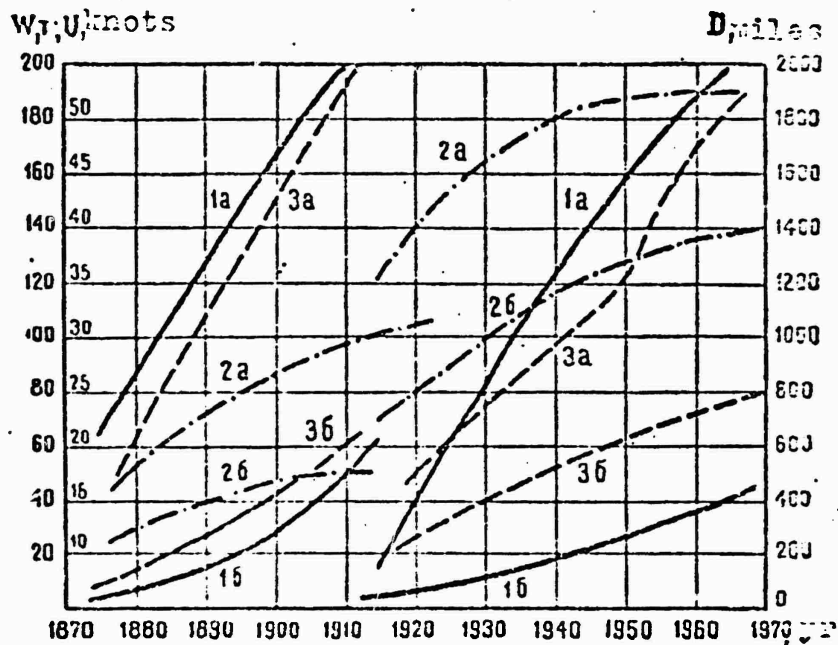

1a- max. displacement (tons); 1b - min. displacement (tons);
 2a- max. speed (knots); 2b - min. speed (knots); 3a- max.
 range (miles); 3b - min. cruising range (miles).

An overwhelming majority of the small boat-minesweepers were specially constructed. Their mission was to combat the mine danger in roadsteads and harbors, in the approaches to bases, and in narrows, and also to carry out mine reconnaissance in coastal areas and to sweep fairwaters for the approach of a landing party to the beachhead.

It is evident that in WW II and the Great Patriotic War small combatants executed rather diverse missions both on a tactical and an operational scale and won a firm place within the composition of the navies. By possessing a relatively great strength, the small combatants brought about the appearance and rapid development of means and methods of combatting them. Thus, even in WW I there were booms and mines opposing the small combatants and rapid firing batteries with short range concentrated fire. In the Second World War, in addition to the above means, gunboats and attack aircraft were mainly used to combat the small combatants. [36]

In the postwar development of small combatants the following basic trends were observed: an improvement in range and accuracy in employing the main armament, the employment of weapons beyond the range of his means of defense against the boats, a strengthening of the boats' means of self-defense, outfitting with technical aids for navigation, communications and detection and radar countermeasures, an improvement in seakeeping qualities, an increase in cruising range while retaining high speeds, the use of new propulsion plants--gas turbine and diesel-gas turbine--and new principles of sustentation (air cushion, hydrofoils).

Small combatants are today recognized to be an integral part of all navies. Their specific weight in the fleets of different countries is determined by the missions confronting the given fleet, the military geographical features of the theater, and the economic capabilities of the country.

It should be noted that although the cost of the construction of small combatants has sharply risen (mainly due to the cost of the electronic equipment, propulsion plants, and armament), nevertheless they continue to remain the most inexpensive combatant: they each cost from 4--6 to 8--10 million dollars to build. A modern small combatant, while retaining the speed of its predecessors (40--45 knots), has a [37 considerably greater displacement (up to 200--300 tons) due to the increase in the power of the armament, in cruising range (from 1000 to 2000 miles), and in seakeeping ability (it is possible to employ the weaponry in sea states of 4 to 5).

In addition to qualitative changes in small combatants, changes have also been brought about in the methods of their operational employment and tactics. Thus, the arming of small combatants with guided missiles has made it possible to destroy the enemy's warships from distances at which the boats themselves remain invulnerable to the guns of the ships being attacked. Guided missile patrol boats already demonstrated their high combat qualities when in October 1967 they sunk the Israeli destroyer ELATH.

It is interesting that the fact of the first sinking in history of a warship by a cruise missile was discussed in the British Parliament and the government came out with a special statement on this subject. And the former US Chief of Naval Operations Admiral Moorer (the present Chairman of the Joint Chiefs of Staff) included the development of cruise missiles and means of combatting them among the five basic problems related to the development of the Navy.

The USA is developing the HARPOON guided missile designed to destroy small combatants, and a guided missile patrol boat armed with the French SS-12 M-type guided missiles (range 6 km). In France the MM-38 EXOCET missile (range 39 km) has undergone tests. In Italy the guided missile systems SEA KILLER (range 3.5--10 miles) and SEA KILLER Mk.2 (range more than 18 km) are being built which have interested many NATO countries (in England, for example, the firm Vosper Thornycroft has built the guided missile patrol boat TENACITY with two twin launchers for these missiles). Work has been going on already for several years in the German Federal Republic on the conversion of SAM guided missiles of the USA and other countries for firing against surface targets.

All of this attests to the great attention to guided missile patrol boats in foreign navies. No less importance is being attached to the creation of means for combatting cruise missiles and their carriers. Thus, in the USA a version of the SEA SPARROW missile for use against small combatants has been tested and installed aboard several major combatants. Ships of the British Navy and of several other states are also being armed with the short range SEA KIT missile system for use against air and small boat targets, and a new SEA WOLF missile system is being built to replace it. At the same time measures are being taken to develop various passive means of protecting surface ships from cruise missiles.

As is seen, guided missile patrol boats are going through a furious development process and occupy an important place in the plans of the naval commands of several countries. In this connection, they are being handed missions which are similar to the missions of torpedo boats. However, the ranges of the missiles, which are greater than those of torpedoes, permit the selection of a position for weapon employment which is beyond the range of the guns of the ship being attacked. Moreover, it is noted that an increase in the firing range of missiles is limited by the range of the means of target acquisition. Therefore it is recognized that it would be useful to devote greater attention to questions of concerted actions by guided missile patrol boats with other naval forces. Thus, several foreign naval experts believe that in certain areas of the high seas, guided missile patrol boats must be employed in company with destroyers, escort ships, gunboats and PT boats, and aircraft (especially attack aircraft) and must be supported by a reliable air defense.

In the opinion of foreign experts, the elements of a covert approach to the target and surprise attack retain their former importance for PT boats. This can be achieved through the small size of the boats, greater range of radar target detection by the small boats than that at which they are detected, and the creation of active and passive jamming of the electronic detection and communications [systems] of the ships being attacked. In order to weaken the gunnery resistance the attack

should be prosecuted by groups from various directions or supported by destroyers, escort ships, gunboats, and aircraft. The appearance of long-range homing torpedoes already today permits employing them from greater ranges without increasing the number of torpedoes in a salvo. [38 It is evident that the further improvement of torpedoes will raise the combat effectiveness of PT boats even higher.

Gunboats are intended both for supporting other forces (e.g., PT boats) and for independent operations. This form of small combatant is extensively used by the USA in Vietnam. There, they carry out such missions as blockading coastal zones, patrolling inland waterways, landing landing parties (or giving them fire support), and gunnery raids against points captured by the patriots. The Americans have created a special operational force the core of which is the gunboats armed with cannon, large caliber machineguns, and mortars. Among them is the latest achievement in American small combatant construction, the ASHVILLE-class gunboat, which is employed in close cooperation with helicopters.

In Vietnam (especially in the delta rivers) the Americans are also using patrol air-cushion vehicles which have a weak gunnery armament, but can take up to 20 soldiers with weapons and rapidly transport them several dozens of kilometers to those areas where displacement boats cannot operate.

The development of antisubmarine patrol boats is following about the same trends as that of the PT boats and gunboats: an increase in displacement, range, seakeeping ability, and armament strength, while retaining their high speed. Many patrol boats have received antisubmarine torpedoes in addition to depth charges, and the electronic equipment has been upgraded.

Minesweeping and minelaying patrol boats have not undergone any basic changes in comparison with those of the WW II period, if one excludes the improvements in their armament and equipment, and also the improvements in their members as a result of progress in small boat construction, which is characteristic of all forms of small combatants.

Progress in science and technology ensures a further improvement in the combat capabilities of small combatants. Experts see a growth in the speed of small combatants and an improvement in their seakeeping abilities in the replacement of diesel gas turbines by combined propulsion plants and also in the construction of small combatants with dynamic principles of sustentation (hydrofoils, air cushion, etc.). Each of these trends in the development of small combatants has been sufficiently known theoretically for a long time, but practical work became possible only in the middle of the 20th century owing to technological advances. Presently, in the USA, Great Britain, and other

states the development of small air cushion vehicle and hydrofoil combatants has entered the final stage of perfecting actual classes. Thus, in the USA, work is being pushed on the preparation of the PLAINVIEW-class antisubmarine hydrofoils and the TUCUMCARI-class gunboats for series construction. Great Britain, the USA, and France are building military type BH-7, BH-8, SK-9B, No. 300, and other patrol air cushion vehicles. Several American SK-5-class air cushion gunboats participated in combat operations in Vietnam.

Many bourgeois experts believe that the patrol air cushion vehicle, which is characterized by high speed, is little affected by the mine situation, is amphibious, can become general purpose, especially in prosecuting ASW missions and in landing landing parties.

Thus, small combatants, which were born in the latter half of the 19th century and have travelled a long and complex path of development, today have become an important integral part of naval forces.

THE PATROL BOATMAN SCHOOL.

by Captain 1st Rank V. Piskunov
Captain 3rd Rank Yu. Kossov

The broad lines and raked superstructure accent the high maneuverability and swiftness of the guided-missile patrol boat. It is not designed as much for long cruises as other ship types. However, service aboard it is difficult in its own way. It demands of a navyman a special physical toughness, quick and clear thinking, and a firm will. It is not accidental that the expression "a patrol boatman must have the courage of a pilot, the fearlessness of a scout, and the toughness of a calvaryman" has been retained for a long time. [39

A constant readiness to put to sea, closeness to the water, high speeds and high-powered weapons with a small crew make up the unique romance of small combatant service. As practice has shown it primarily attracts young and strong men capable of feeling this inspiring picture of a patrol boatman.

While still in school Senior Lieutenant A. Levich prepared himself for service aboard large combatants. However, he ended up on a guided-missile patrol boat. Things went well in the department. Within a year he became the Executive Officer. Then they sent him to courses for ship commanding officers. Having completed them, A. Levich was assigned to a large ship. It seemed that his dream as a cadet had been fulfilled. But the Senior Lieutenant dreamed of returning to his guided-missile boat. Small combatant service had become part of him and he did not want to part with it.

Of course, the captain's bridge aboard a large ship is no small aspiration. Officers approach it by stages on the service ladder of years. However the bridge for a patrol boatman is a closer goal.

Officer E. Kuleshov began service in the XO billet aboard a patrol boat. Physically strong and having good specialist training, he had quick reactions and daring. In his very first year of service he received authorization for independent command of a ship and soon became a CO.

A short time passed and the guided-missile patrol boats put out to carry out a tactical firing mission. The boat of E. Kuleshov was sent to reconnoiter. It had to detect the enemy covertly and vector the entire group to him. Knowing the directions well and acting with initiative, the officer successfully handled the mission. Having supported the group attack, in expanding its success, he himself made an attack

and hit the assigned target with an accurate salvo. This victory permitted the patrol boatmen to become Navy prize winners.

The foundation for a future commanding officer is laid within the walls of the naval school. However, the officer acquires the main qualities of a CO aboard ship. Here he perfects his personal, tactical, and special training, develops command skills in himself, learns to work with men to lead them and to be responsible for them. The ship's boat is a good aid for the patrol boat CO. In steering it he masters nautical practice, polishes his eye for the sea, and learns to feel the effect of the wind and waves.

Captain-Lieutenants V. Chmarov, L. Gorokhov, and M. Inyukhin specialized in missile in school. After the third year they did not study any nautical practice or navigation. Therefore they had to study questions of shiphandling almost from the beginning. The development of the commanding officers was slowed. Not having solid skills in chartwork, they particularly were unable to rapidly calculate the probable position of their own ship and to handle dead reckoning. At times it even seemed that the officers did not even know these questions for they often became lost at sea.

In watching them closely the navigational officer of the unit came to the conclusion that the men had a poor sense of the passage of time and employed his own method of practical training. Whereas before, the officers were given the complete text of the mission, now he made up exercises for them in which the very same elements were put in the form of individual tactical problems, and in strict accordance with the actual time. And gradually after several practical training sessions, the skills of the officers became stronger and they began to operate more confidently at sea.

He who thinks clearly, talks clearly--this is a folk saying. The patrol boatmen have reworded this saying in their own way: He who thinks clearly, acts surely. And today they are only permitted to put to sea after full mutual understanding has been achieved in port. These questions are worked out in classes, in the course of group exercises and in tactical scull sessions. The officers learn to think out every maneuver, every method.

Using models of the boats the division [division] commander runs through the entire course of the forthcoming actions with subordinates on the chart. The participants in the practical classes work out the concrete elements of the mission just as they will have to operate at sea.

The attack is the concentrated expression of the knowledge, experience, and will of the patrol boat officer. It is precisely in it that his mastery and the entire talent of the military man is revealed. And each time we are convinced that where they have worked steadily in port, they have been triumphant at sea.

Captain 3rd Rank A. Dzhigero usually distinguishes himself with his decisiveness and tenacity. And this is not surprising. He is sure of the skill of the crew and of the reliability of the equipment and weaponry.

This instance comes to mind. After the successful completion of a combat training mission the boat was returning from the sea. During the approach to the port according to the schedule the crew of Captain 3rd Rank A. Dzhigero was supposed to carry out a record exercise of giving aid to a ship which had "lost way." The mission is generally not difficult, but the weather had sharply deteriorated, a strong wind was blowing, and the waves had also become rough. The senior officer had doubts about the advisability of carrying out the exercise.

"Yet what if help were actually needed?" asked the boat's CO. "Would we wait for better weather?" And he added: "The boat is not only working out a problem, it is also taking an exam. And a strong wind even aids in checking how capable our crew is."

The officer was confident of the schooling and teamwork of the men. Maneuvering skillfully, the boat approached the "flounder" and took it under tow. The crew received an outstanding grade for carrying out this exercise.

At first glance it could seem that the CO had taken an unjustified risk: the maneuver was difficult and anything could happen. But A. Dzhigero is an experienced navyman. He has served on the boat for a long time, knows its maneuvering qualities well, and handles it confidently. For him the given maneuver was a stage in improving his mastery.

Captain 3rd Rank A. Dzhigero thoroughly shares his wealth of experience with subordinates. He is aiding his Executive Officer, Captain Lieutenant Gorokhov, to master shiphandling problems, to study the boat thoroughly, and to receive authorization for independent command of a ship.

Today the Captain-Lieutenant commands a patrol boat. Yet even today having ascended to the bridge he inevitably consults with his former CO. A. Dzhigero also has a careful regard toward the training of his first assistants--the warrant officers and petty officers.

The patrol boatmen are now having a hot time of it. They are cruising a great deal, while working on tactics. And every day brings happy news. All the crews are keeping their words and the obligations assumed by them for that remarkable jubilee--the 50th anniversary of the formation of the Soviet state--are being fulfilled.

THE EFFECT OF OWN ACOUSTIC INTERFERENCE OF
A SHIP ON SEARCH EFFECTIVENESS

by Captain 2nd Rank-Engineer M. Filyukov

By own acoustical interference of a ship we mean the noise created by the ship. By affecting the sonar equipment mounted on the ship the interference makes it difficult to detect targets and thereby can have a decisive influence on effectiveness. [81]

Taking this into account, let us make an analysis of the effect of own acoustical interference of a ship on the effectiveness of a search for underwater targets with sonar.

Let us take the probability of target detection P_0 , the most illustrative, objective, and basic indicator for any type of search, as the efficiency criterion.

For the sake of simplicity let us examine a search for a nonevasive target, located within the limits of a region of area S , being carried out N ships of the same class independently of one another. In this case the probability of target detection can be calculated with the formula:

$$P_0 = 1 - e^{-\frac{2DV_0NI}{S}} \quad (1)$$

where D is the target detection range of the sonar ($D \geq S$); V_0 is the mean relative speed of the search ship and target; and t is the search time.

Let us simplify expression (1) in order to represent the effect of own acoustic interference of a ship on the probability of target detection more vividly. For this purpose let us expand the exponential function in formula (1) into a power series and limit ourselves to two members of the expansion. Then for P_0 we get:

$$P_0 \approx \frac{2DV_0NI}{S} \quad (2)$$

Expression (2) is numerically equal to the mathematical expectation of the number of detections and yields a slightly higher P_0 value than formula (1). Let us also note that formula (2) is valid if the right hand part of it does not exceed unity.

From formula (2) it is clear that with given N , S , and t , and when V_p is known, the probability P_o will be completely determined by the target detection range of the search ship's sonar equipment. By using the range equation known in underwater sound theory, we can show that for the same types of sonar with identical parameters (when the other search conditions are equal), the target detection range will entirely depend on the ship's level of own acoustic interference. Thus, if the search is made with the same types of sonars having different levels of own acoustic interference, for example U_{n1} and U_{n2} , where $U_{n2} > U_{n1}$ (the other search conditions being equal), then the strictly defined target detection ranges D_1 and D_2 will correspond to these interference levels, and consequently so will the probabilities of target detection P_{o1} and P_{o2} , where $D_2 < D_1$, and $P_{o2} < P_{o1}$.

Having divided P_{o1} by P_{o2} we obtain expression (2) [which shows] that the probability of detection by ships having an interference level of U_{n2} in comparison with ships having a level of U_{n1} decreases by a magnitude proportional to the ratio of the ranges, i.e., [82

$$\frac{P_{o1}}{P_{o2}} = \frac{D_1}{D_2}. \quad (3)$$

If now by using the sonar range equation we insert the D_1 and D_2 values into formula (3), then we obtain the following functions relating the probability of target detection to the level of a ship's own acoustical interference during a search using the same types of sonar: in the echo-ranging mode-

$$\frac{P_{o1}}{P_{o2}} = \left(\frac{U_{n2}}{U_{n1}} \right)^{1/2} 10^{-0.036\beta(D_1 - D_2)}; \quad (4)$$

in the listening mode-

$$\frac{P_{o1}}{P_{o2}} = \left(\frac{U_{n2}}{U_{n1}} \right) 10^{-0.05\beta(D_1 - D_2)}. \quad (5)$$

where $\beta = 0.036f^{3/2}$ is the free-space attenuation factor of sound in water in db/km, and f is the sonar operating frequency.

To simplify the effect of sound attenuation in expressions (4) and (5) we may make $\beta = 0$.

Then for the echo-ranging mode [we have]:

$$\frac{P_{o1}}{P_{o2}} = \left(\frac{U_{n2}}{U_{n1}} \right)^{1/2}. \quad (6)$$

and for the listening mode:

$$\frac{P_{v1}}{P_{t2}} = \frac{U_{n2}}{U_{n1}} \quad (7)$$

From expressions (6) and (7) it follows that the basic factor affecting the efficiency of a search for underwater targets being carried out with the same type of sonar equipment is the level of a ship's own acoustic noise. Thus, the greater the level of a ship's own acoustic noise, the lower the probability of target detection.

It is easy to note that in this case in order that the given target detection probability does not decrease ($P_o = \text{const}$), it is essential to increase the number of search ships (the detailed forces) by an amount determined from the relationship:

$$\frac{N_2}{N_1} = \left(\frac{U_{n2}}{U_{n1}} \right)^{1/2} \quad (8)$$

when searching for the target in the echo-ranging mode, and

$$\frac{N_2}{N_1} = \frac{U_{n2}}{U_{n1}} \quad (9)$$

in the listening mode, where N_2 and N_1 are the number of ships necessary to search with a given probability ($P_o = \text{const}$) at ship own noise levels corresponding to U_{n2} and U_{n1} ($N_2 > N_1$ and $U_{n2} > U_{n1}$).

Ratios (6) and (9) can serve for an approximate estimate of the effect of ship own noise level on search efficiency and the efficiency of the detailed forces in any form of search with the same type of sonar.

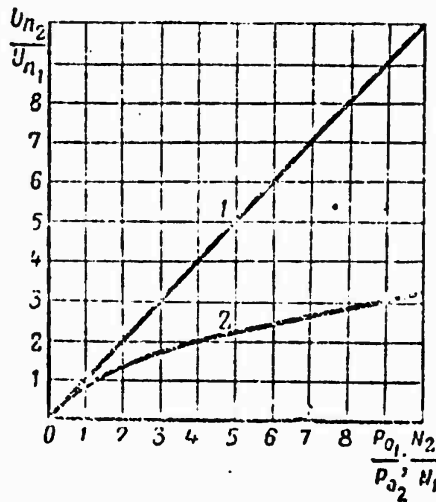

The figure shows the relative changes in target detection probability and in the detailed force as a function of the relative change in ship own noise level calculated using formulas (6) and (9) (1 is the listening mode and 2 is the echo-ranging mode).

From the figure it is seen that a doubling of ship own noise level leads to a reduction in the target detection probability or to a need to increase the number of search ships: by a factor of 2 in the listening mode and by a factor of 1.4 in the echo-ranging mode. This example clearly attests to the fact that the level of ship own noise has a considerable effect on the search efficiency and on the detail of forces.

In conclusion it should be noted that the own-ship's noise level can increase during operation. Therefore the uncovering and elimination of causes and sources of noise is of extremely important significance to the operation of sonars for ships when executing search missions.

SONAR BEACONS USED BY NATO NATION NAVAL FORCES

by Captain Second Rank-Engineer B. Shishkin
Captain Lieutenant-Engineer V. Peterkov

A variety of equipment contained in towed or self-propelled submersibles is used for oceanographic studies, prospecting, and other underwater investigations. Their effectiveness depends, to a very great extent, on knowing the exact point of location of the submersible. The coordinates of the position should be determined with an accuracy in units of meters. [83

In May 1967 the Honeywell Company announced that it was developing several varieties of acoustical instruments initially designed for use in petroleum survey work along the coastal shelf. The requirements imposed on these devices called for a less than 15 meter error at a depth of 4400 meters, or an error equal to 0.3% of the depth. The theoretical possibilities for designing such systems included long base line systems and those with short base lines known as the phase comparison system. A single beacon disposed on the bottom and several (usually three) acoustic receivers mounted on the ship are used in the phase comparison system. The position of the ship relative to the beacon is determined by the phase differences of incoming signals. The company expressed its preference, on the basis of test results, for the phase comparison system and proceeded to develop a model for holding a ship at a fixed position with an accuracy of 0.5% of the depth at that point.

The beacon planted on the bottom transmits a steady signal with a period exceeding the transit time by the sonic oscillations of the hydrophone base line. It is received by three hydrophones on the vessel and transmitted to phase computers which determine values that are proportional to the time difference in arrival of signals at two hydrophones with respect to a third, or reference, hydrophone. The information received is averaged out and depicted on the coordinate grid.

A typical navigational radiator consists of a cylinder about three meters long with a diameter of 0.53 meters. On reaching the bottom the transducer is detached from the anchor, which contains the power supply battery and electronic apparatus, and rises with the aid of a float. The latter extends the cable, holds the transducer 100 meters above the bottom (but not less than 17 meters below the surface). Standard beacons operate on a frequency band of from 6.6 to 15 kilohertz.

The Raytheon Company of the United States has developed a shipboard navigational system known as "Bench Mark" for use in determining a ship's position by bearing and distance from a single standard submarine sonar beacon. The distance to the beacon can be determined by [84

interrogator-responder principle or by measuring the time of passage of the signal from the beacon to the ship with the aid of synchronized reference frequency generators coupled into the beacon and ship equipment circuit.

The second method is more precise, reliable, and does not require a receiver on the beacon; it enables several ships simultaneously to determine their position from a single beacon. The beacon radiates one pulse with a duration of 25 μ secs at three second intervals. It is expected that the instrument error of the system will not exceed $\pm 2^\circ$ in the relative bearing and one μ sec of time in computing distances to the beacon. This is equal to $\pm 3.5\%$ of the slant range in a circular error of site and 1.5 meters of range, respectively.

The U.S. Naval research vessel MISSIA CAPISTRANO has completed a two-year period of testing an automated system for maintaining a ship's position in a given spot on the basis of signals transmitted by a sonar beacon at the bottom. The system was developed by the General Motors Corporation. It can operate on signals transmitted by a sonar beacon, by the "Loran-C" radio station, as well as on signals given by an operator and a controlling computer; this insures holding the vessel at a given spot over a prolonged period of time at depths up to 3960 meters.

A system developed by EGLG International consists of the Model 215 onboard equipment and one or several underwater model 276 responder beacons planted on the sea bottom. The onboard equipment includes the KT-16 interrogator and two towed KT-20 transducers connected by cable to the interrogator. Each beacon responds only to a specially coded signal. The responder beacon has a power supply source adequate to maintain uninterrupted operation for 800 hours (it can remain on the sea bottom for two years) and is used at depths up to 300 meters. The beacon has a diameter of 22 cm and a length of 2.5 meters.

A patent (Cl 340-5, No. 3421138) has been awarded in the United States for a marine navigation system consisting of a shipborne ultrasonic wave generator, sonic receivers placed on the sea bottom, as well as a radio communications line between the sonic receivers and the vessel. The distance between the ship and receiver is determined on the basis of the time difference of arrival of sonic and radio signals.

Sonic beacons are deemed the most accurate means of navigation of submersibles. Two types of such underwater beacons have been developed: those with continuous radiation and those which radiate on interrogation (responder beacons). Beacons of the first type generate prolonged series of pulses at a certain frequency with a set periodicity of repetition, and are used to provide sailing information for ships in comparatively extensive areas. Responder beacons have a shorter range of operation and can be used as an aid in the navigation of submersibles.

One of the systems developed by the Bendix Company of the United States consists of three beacon responders placed on the bottom of the ocean from one to ten miles apart, responders on submersibles, and an interrogator with computer equipment on the surface vessel. To determine the position of the submersible the surface ship beams a pulse at the interrogation frequency of the submersible and the latter beams a response signal at the interrogation frequency of the beacons. On receiving the signal the beacons radiate response pulses, each on its own frequency. Thus, for each interrogation the ship receives four response signals. On the basis of this information and ship position data obtained from interrogation of the beacons alone, the position of the submersible is determined by computer and transmitted to the submersible via the underwater sonic communication line. Accuracy in determining the position is within a few meters. The system's range of action is 15 miles.

A system with responder beacon for determining the position of a submersible relative to a surface vessel proposed by the Marconi International Company of England is presently under development. In this system the beacon responder is mounted only on the submersible. The beacon radiates pulses at a frequency of 48 kilohertz in response to an interrogation signal from a surface craft using a frequency of 24 kilohertz. Three transducers are mounted under the ship's keel: one in the middle to beam interrogation pulses, and two others spaced 25 meters [85] apart, fore and aft of the former to receive the response. The interrogator beams 60 or 20 pulses per minute, depending on the distance of the submersible from the surface vessel. Knowing the time interval between the radiation of the interrogation pulse and the return of the response signal it is possible to determine the slant range between the submersible and one of the receiver transducer; this is reflected on the digital display unit and tape recorder. The time delay between the arrival of the responder signal at the forward and after receivers is simultaneously measured and then reflected in digital form on the cathode ray tube. The recorder and the CRT are used in computing the results of measurements when it is practically impossible to obtain readings from the digital display unit when noises or other types of interference prevail.

Analysis of foreign press materials indicates that the NATO countries are devoting much attention to the development and utilization of sonar beacons. The main objective of the investigations is to develop equipment for determining the position and course of surface vessels and submarines, making more effective use of weapons, and further promoting geological, hydrographic, and survey operations.

Of the several versions of beacons under consideration, current preference is for the deep water variety. These have a more extensive zone of operation and are less vulnerable to oceanographic influences.

AIR SPACE REGULATIONS

by Captain of Justice A. Zhdanovich

With the appearance of flying machines a new field of international law began to be developed--air law, represented by a body of legal norms which regulate relations between states with regard to the use of air space and determine the legal status of aircraft and their crews. [89]

Presently in air law there is no generally recognized definition of the concept of "air space." However, many scientists and specialists working in this area consider that this means the atmosphere surrounding our planet.

The air spaces stretching over land territory, the inland and territorial sea of a state, and the high seas have different legal regimes. Let us examine these differences in light of modern air law.

The Legal Regime of the Air Space of a State. The air space located over the land territory and the inland and territorial waters of a state is an integral part of its territory and is under its full and exclusive sovereignty. The question of the extension of a state's sovereignty to the air space acquired practical significance at the beginning of the 20th century in connection with the development of air navigation and aviation and by the need of every state to ensure its own security. [80]

Modern international law was strengthened by the principle of full and complete sovereignty of the state over its own air space. This principle was enunciated at conferences in Paris in 1919, Madrid in 1926, and Havana in 1928. In 1944 the International Civil Aviation Convention (Articles 1 and 2) was approved in Chicago.* Today the

*Went into force on 4 April 1947 (for the USSR, on 14 November 1970).

In the notification on joining the Convention the Soviet government made the following statement: "...the regulation of Article 2 according to which territory under the sovereignty, protectorate or mandate is recognized as the territory of the state is outmoded and contradicts the Declaration of the General Assembly of the United Nations on the granting of independence to colonial countries and peoples (Resolution 1514 (XV) of 14 December 1960).

principle of full and exclusive sovereignty over their air space has also been strengthened by the national air legislation of almost all countries. Every state has a right to have a monopoly on flights in its own air space and to determine the procedure for the aircraft of other countries to use it.

Under the 1944 Chicago Convention regulating international flights of civil aircraft every country has the right to establish regulations for flights over its territory. Bilateral intergovernmental agreements are the principle standard acts in accordance with which routes for regular air lines between countries and the conditions for their operation are established.

In contrast to regular flights, nonregular international aircraft flights are made, as a rule, upon preliminary permission each time by the interested states.

The Soviet Union, which is a member of the International Civil Aviation Organization founded on the basis of the 1944 Chicago Convention, also arranges its mutual relations in the area of regulating international traffic in accordance with the enumerated regulations.

In the USSR the main flight rules for both domestic and foreign civil aircraft are presented in the Air Code of the Union of Soviet Socialist Republics. According to this Code all nonmilitary foreign aircraft can make flights only along established international air tracks in the air space based on agreements on air traffic concluded by the Soviet Union with other states or on special permission for special flights issued by the Ministry of Civil Aviation. The list of airports and air tracks open for international air traffic is approved by the USSR Council of Ministers and is announced by the USSR Minister of Civil Aviation.

As for military aircraft, they must obtain special permission diplomatically for their flights through the air space of a foreign state. In this connection, during the flight over the territory of the foreign state the military aircraft must strictly adhere to the flight route, speed, and altitude in accordance with the obtained permit. However, in accordance with existing international customs and rules, special permission for aircraft flights over foreign territory is not needed in cases when the head of the foreign state or a diplomatic representative accredited by the government of the given country is aboard the aircraft; when military aircraft are accompanying the aircraft with the head of state or government (the number of escorting aircraft is agreed upon in advance or is indicated in a special agreement); and when an aircraft suffers an accident and is forced to make a landing.

In the first two cases it is essential to make the appropriate notification of the proposed flight of the military aircraft to the foreign government so that the aircraft with the head of state or government will not be taken for an aircraft infringing on the air space with all of the consequences stemming from this.

Flights of Soviet military aircraft in the air space of the USSR [91] are made in accordance with current rules, directives, guidelines, and other documents published by the competent authorities.

Current norms of international air law and national laws forbid the flights of pilotless aircraft over the territory of other states without preliminary permission. Thus, the Chicago Convention (Article 8) establishes that "No aircraft capable of flying without a pilot may make a flight... without special permission... or without observing the conditions of this permission."

The penetration of any foreign aircraft into the air space of a state is the most gross infringement of its territorial inviolability. The state has the right to take appropriate measures to stop such actions.

In the air space stretching above the international and territorial waters of a state flights of all aircraft can be made according to the same rules as in the air space above the land territory. However in contrast to merchant ships, which enjoy the right of innocent passage through foreign territorial seas, aircraft have no "right of innocent flight" whatsoever in the air space above them. The procedure for aircraft flights over straits overlapping territorial seas also stipulates this provision.

Today International Conventions and national legislation of littoral states have established rules for aircraft flights through some of these straits. Thus, in accordance with the International Convention of the Regime of the Black Sea Straits adopted in 1936 at Montreux (Article 23), civil aircraft can cross the zone of these straits via routes declared by the Turkish government under the condition of a general notification of the Turkish government for regular flights. For special flights notification should be given not less than three days prior to takeoff. The Convention does not establish any sort of rules for flights by military aircraft over the Black Sea Straits. According to Turkish law permission must be obtained diplomatically for this.

The flight regime of military aircraft over the Baltic straits in peacetime is actually regulated by Danish and Swedish legislation. Presently it is free with the observance of certain conditions. Thus, in accordance with Article 15 of the "Decree of the Admittance of Naval Ships and Aircraft into the Limits of Danish Territory in Peace-

time" of 25 July 1951* for flights of foreign aircraft over the international territorial waters of the Great Belt and the Sound** it is

* Sbornik regional'nykh soglasheniy i zakonodatel'nykh aktov zarubezhnykh gasudarstv po voprosam moreplavaniya (Collection of regional agreements and legislative acts of foreign states on navigational questions) Vol. I, Izd-vo MO SSSR, 1968, p. 228.

** The territorial sea of Denmark is divided into inner and outer territorial waters. The inner territorial sea has a breadth of 3 miles.

necessary to establish radio contact with the stations of the Central Air Traffic Control Service in Copenhagen whose directions must be observed during the overflight. In addition, aircraft flights above the Great Belt must take place above the center line of the outer territorial sea and in the Sound, at the greatest possible distance from the Danish coast.

The procedure for flying over the Swedish territorial sea in the Sound was established by "Royal Decree on the Admittance of Foreign Naval Ships and Aircraft to Swedish Territory" (No. 366 of 3 June 1966)* whose regulations extend to all aircraft used for noncommercial purposes. This decree indicates that military aircraft of foreign states have the right to cross the air space above the territorial sea in the Sound without any sort of permission only between the lines of Cape Kuplin--Cape Gilberg-Hoved and Cape Falsterb--Stevens Light, and in all other cases permission is needed**.

* Op. cit. Collection of regional agreements and legislative acts of foreign states on navigational questions. Vol. I. p. 392.

** Only aircraft suffering an accident or those used by heads of foreign states visiting Sweden need no permission.

Under the rules of these countries military aircraft during flights over the straits must not have ammunition or photographic film.

Thus, although legally the flight of foreign military aircraft in [92 the air space over the Great Belt and the Sound is possible without any permission, however in practice, it is difficult to maintain a flight track above them especially for modern jet aircraft.

The Legal Regime of the Air Space Over the High Seas. In the Geneva Convention on the High Seas of 1958 the basic principle of international maritime law was strengthened--the principle of freedom of the high seas, which also includes freedom of flight. Therefore no state can use the air space over the high seas for purposes incompatible with international law and each state is obliged to refrain

from any sort of activities limiting the rights or infringing on the reasonable interests of other countries (for example, intentional and dangerous overflights of foreign warships and auxiliaries at low altitudes by military aircraft of states of other flags; actions with respect to intercepting foreign aircraft over the high seas and approaching them to impermissibly close ranges which creates a real threat to flight safety and other dangerous illegal acts).

The "Agreement between the Government of the Union of Soviet Socialist Republics and the Government of the United States of America on the Prevention of Incidents on the High Seas and in the Air Space Above Them"* signed on 25 May 1972 during the visit of U.S. President Nixon to the Soviet Union is supposed to serve to prevent such actions and also maintain the basic norms and principles of international law and also to ensure flight safety over the high seas and ship navigation on the high seas. The Treaty provides that aircraft crew commanders** of both parties are obliged to display the greatest caution

* Pravda, 3 June 1972.

** "Aircraft" in this Treaty means all forms of military manned flight vehicles heavier and lighter than air with the exception of space vehicles.

and good sense in approaching aircraft and warships of the other side operating on the high seas. In the interests of mutual safety crew commanders of US and USSR aircraft in the air space over the high seas must not interfere with ships in launching or landing aircraft and also must not make simulated attacks by simulating weapons employment against aircraft or any warship, or carry out various flight maneuvers above combatants or throw various objects near them in such a way as to represent a danger to the ships or interfere with navigation. While on the high seas within sight of one another, US and USSR warships must raise appropriate signals of their intentions to begin support of aircraft launches or recoveries. During night or instrument flights above the high seas US and USSR aircraft must keep air navigational lights turned on (when this is possible).

In accordance with the Treaty the USSR and the USA will provide through an established system of notices and warnings to mariners (as a rule not more than 3--5 days beforehand) a broadcast of a warning concerning operations on the high seas which represent a danger to navigation or flights.

Military aircraft in the air space over the high seas, while subordinate only to the laws and instructions of their own state, must adhere to all legal norms governing the regime of that particular area

of the World Ocean. Therefore, they are obliged to carry out the rules of air flight safety and not to contaminate the sea with radioactive and other harmful substances. The responsibility for these actions lies with the state to which the aircraft belong.

Under the 1958 Convention on the High Seas, military aircraft over the high seas (like naval ships) in accordance with the authority received by them from their own state are able to take certain strictly limited forceful actions: tracking and helping to detain ships not possessing immunity in case of a violation by them of the laws and rules of the littoral state; to participate in a fight with pirate ships and aircraft* and in their capture and also in the capture of ships engaged in slave trading. [93]

* O bor'be s piratstvom (On the struggle with piracy), see Morskoy sbornik, No. 5, 1967.

Certain countries are trying to limit the rights of other states in enjoying the freedom of air space over the high seas by the illegal introduction of various zones of control over the flights of aircraft of other states. Thus, under the guise of ensuring its "own security from enemy aircraft," the USA has established over the high seas of the Atlantic and Pacific Oceans "air defense recognition zones," 300--500 miles wide, which girdle the American coastline. In 1965 the USA in a unilateral procedure declared a 100-mile zone along the Vietnam coast a combat operations zone for their troops. They use the zone for constant control over flights of foreign aircraft and ship navigation. In 1958 Greece introduced control over flights of foreign aircraft over the Strait of Otranto where there is a strip of high seas (and consequently also an air space over it) about 22 miles wide. The South Korean government is trying to establish the very same kind of control in the western part of the Korean Strait. For this purpose they are advancing the demand that aircraft flying over the so-called Rhee Line report by radio, the time, route and altitude of the flight to a special service in Pusan. Aircraft not reporting such data are considered violators of the air space.

The Soviet Union and other peace-loving countries regard such actions as illegal and are decisively coming out against violations of the freedom of the air space over the high seas.

Presently a series of problems have to be solved in international law among which the problem of freedom of aircraft flight over international straits is of particular import. Along with other questions it is scheduled to be examined at the forthcoming conference on maritime law (Resolution No. 7250 of 17 December 1970 of the 25th Session of the UN General Assembly). Three sessions of the UN Committee for the preparation for the above conference which were held in March and July-August 1971 and also in March 1972 indicated that the problem of

the freedom of aircraft flights over international straits is one of the complex problems of modern international maritime law.

The USSR delegation in the UN Committee for preparing for the maritime law conference is coming out in support of freedom of international flights. It is proceeding from the fact that the question of the freedom of aircraft flights over such straits must be decided taking into account the interests of both the states contiguous to the straits and to all the other states. For this purpose it is advisable to establish definite international norms which are obligatory for all guaranteeing freedom of aircraft flight for all states over international straits on an equal basis. No state including a state contiguous to a particular strait should prevent or create any kind of difficulties for it. Moreover, the question of the freedom of aircraft flight over the most important international straits should be decided in such a manner as to create appropriate guarantees of the security of states lying on the straits and also to eliminate any possibility of doing any damage to them.

The current need to ensure freedom of aircraft flights over international straits is occasioned by the fact that the trend toward a general increase by coastal states of the breadth of their territorial sea could lead to the withdrawal of freedom of use of more than 100 international straits, which would inflict great damage on the economic and other interests of all states of the world.

The successful solution of the question of freedom of aircraft flights over international straits should serve as a cause for strengthening world peace, the expansion of economic and other relations between states and the development of good-neighbor relations between them.

CARRIER-BASED ASW HELICOPTERS

by Colonel-Engineer A. Ivanov
(From materials in the foreign press)

In the overall structure of military preparations by the imperialist states, and by the USA and Great Britain in particular, special attention is being devoted to the development and expansion of antisubmarine-warfare (ASW) forces and equipment, including aviation. Along with the improvement in carrier-based aircraft, more and more significance is being attached to the creation of modern ASW helicopters and their broad introduction on ships of the fleet. The expensive but ineffective--and, furthermore, physically obsolete--ASW aircraft carrier is being phased out in favor of helicopter carrying combatants--cruisers and frigates. Basically new aircraft-carrying ships of the DH class (USA) and TDS (Great Britain) are planned. Their designers consider them capable of supporting ASW units of ships and ocean convoys beyond the zone of shore-based aircraft coverage. [94

Various versions of aircraft-carrying ships are being worked out with displacements from 5000 to 20,000 tons and speeds up to 30 knots. It is envisaged that some will have a flight deck covering half the length of the ship, with an "island" superstructure. In contrast to earlier aircraft carriers, these ships are of lighter displacement, simpler design, and lack a sonar capability. The amount of electronic equipment they carry (except communications gear) has been minimized.

It is planned that the DH, the prototype of which will apparently be the US aircraft carrier GUAM, will carry a mixed air group consisting of six vertical-takeoff-and-landing (VTOL) aircraft. The latter are intended for the air defense of the ship and for performing strikes against targets at sea.

The TDS ships may carry up to 14 SEA KING helicopters or HARRIER aircraft in addition to their ASW helicopters.

The SH-3 SEA KING helicopters are presently in the armament of the navies of the USA as well as Great Britain, Canada, Japan, Denmark, Brazil, Italy, and Spain. Of greatest interest is its SH-3D modification--a craft which incorporates better (as compared with the others) weight and flight characteristics and more improved electronics.

The SH-3D helicopter (figure 1) has a single-rotor design with a steering rotor and a three-wheel landing gear. The helicopter's rotor blades and tail assembly are foldable, which substantially decreases its dimensions and permits it to be carried not only on helicopter carriers, but on frigates and destroyers. The fuselage belly has the shape of a boat, which makes it possible to touch down at sea. However, its bottom is not completely watertight, so that putting down in water is possible only in emergencies.

Its power plant consists of two T58-GE10 turboprop engines with 1400 hp each (this is 200 hp greater than that of the first version of the SH-3A). Fuel is stored in two-section forward and aft tanks with capacities of 1300 and 1330 liters, respectively, and a midships tank holding 550 liters. It is anticipated that an auxiliary 520-liter tank will be added.

Electronic equipment on the helicopter permits the searching for [95 and destroying submarines night or day and in bad weather. The equipment includes the Bendix AN/AQS-13 dipping sonar, MAD, a set of sonobuoys, the AN/APN-130 Doppler navigational radar, a radio altimeter, an IFF (Identification Friend or Foe) system, and short-wave and ultra-short-wave communications gear. Furthermore, the helicopter is equipped with an automatic control and stabilization system which substantially broadens its capabilities during submarine search. This system permits: stabilization of the helicopter relative to its three axes during piloted maneuvering; maintaining position, course, and altitude while cruising; shifting from cruising to hovering and back again; and automatic maintenance of altitude and control during hovering.

For armament the helicopter carries four Mk 54 depth bombs and four Mk 44 (Mk 46) torpedoes. The weapons are suspended in four carriers, two on each side. The helicopter can also be used for minesweeping, landing assault teams, evacuating wounded, search-and-rescue operations, and cargo transport. During troop transport, 20 men can be fitted into the cabin. In the evacuation of wounded, 12 stretchers can be carried. In the transport version, a load weighing up to 3.6 tons is slung under the fuselage.

The Sikorsky Company is presently carrying out further work on updating the SH-3.

The modified SH-3H SUPERLAMs helicopter (figure 2) will carry a new sonar, search radar, and MAD. Flight tests have begun.

The British HAS Mk 1 SEA KING helicopter. This is a unique modification of the American SH-3E helicopter. Its engines and the on-board electronic equipment have been replaced by British-made equipment. It is manufactured under license. By 1973, the British plan to turn

out 60 such craft, with production continuing until the end of the 1970's. The Westland Company, which is producing these craft, plans to improve the helicopter by arming it with the MARTEL or KORMORAN guided missile, which will boost the craft's takeoff weight by 2 tons.

Its power plant consists of two 1500-hp Gnome H.1400 turboprop engines. The engine's dry weight is 1500 kg.

The on-board electronic and search gear consists of the Plessey Company's Type-195 dipping sonar, the AW.391 search radar, the AD-580 Doppler navigational system, the AN/APN-17 radioaltimeter, the Sperry [96 Company's Mk 7B radiocompass, the Mk 31 automatic flight-control system.

The automatic control (and stabilization) system makes it possible to perform programmed flight, including a large range of speed and altitude combinations, during which the helicopter can be automatically shifted into hovering, which substantially facilitates piloting during searches. This system permits the precise maintenance of the craft's attitude when dipping the sonar during hovering, at which time the angle at which the cable enters the fuselage serves as a signal to the automatic control system: this angle need not always be 90°, because corrections for the wind force and sea state are taken into account. A correction to the angle of inclination of the cable is determined and fed into the system by means of a computer. The required altitude is maintained through the use of a radioaltimeter. The basic navigational data--azimuth, drift angle, and ground speed--are displayed on the indicator.

For armament it has four Mk 44 torpedoes or four Mk 11 depth bombs. In addition, there are plans to load 12 depth bombs, four floats for laying a smoke screen, and two sea signal buoys inside the fuselage. A machine gun can be mounted on the aft frame in the starboard cargo hatch.

All types of weapons can be controlled from the pilot's control panel (figure 3). Communications gear includes the AN-ARC.52 ultra-short-wave radio set with a homing receiver, back-up ultra-short-wave set, a shortwave radio set, an aircraft intercom system, and an IFF system.

Prior to 1970, the QH-50 light drone helicopter was part of the armament of the US Navy. It was the sole radio-controlled craft in use aboard American destroyers since 1963 in the DASH system. Experience in using them showed that these helicopters did not satisfy present-day demands, and they have been superseded largely by piloted craft. Their basic drawback was their short range, their uselessness for night operations, and their high accident rate. Of the 750 built by the Gyrodyne Company, 362 crashed due to various structural flaws and failure of the control system. Thus, the QH-50C has been pulled out of operation.

In April of 1970, the naval command approved a tactical assignment for the design of the LAMPS light, multi-purpose helicopter.

Work is being carried out on two basic programs. The first anticipates the use of SH-2D SEALITE helicopters (figure 4)--a modification of the HH-2D SEA SPRITE multipurpose helicopter, while the second involves the construction of a lighter craft based on series-produced helicopters.

[97

In March 1971, flight tests aboard ships began on the SEALITE. It is planned to convert all SEA SPRITE helicopters into those of the LAMPS system, and to turn out the first 20 craft in 1971-1972.

For training the flight and technical personnel, two (30 and 31) squadrons of light ASW helicopters have already been formed. The SEALITE, depending on the gear and armament it carries, is intended for use in three versions: ASW, shielding ships from ship-to-ship missiles, and multipurpose. In the ASW version, it will be armed with two Mk 46 torpedoes, a system for launching 15 sonobuoys, the AN/APS-13 sonar, the new AN/APN-182 Doppler radar set, MAD, and a device for launching smoke rockets (markers).

To protect ships from guided missiles, there are plans to sling two AIM-7E SPARROW-class air-to-air guided missiles, and gear to generate active and passive jamming of guided-missile homing systems.

This helicopter can be used also as a decoy for guided missiles aimed at the ships it is protecting. By the use of a special device, it is supposed to imitate the surface target. As the missile approaches the helicopter, the latter, through the generation of radio jamming, draws it off course. There are also plans to equip the craft with television and infrared gear.

Helicopters are being equipped with more sophisticated navigational gear, including a new Doppler navigational radar, data processing and transmission systems, and a system indicating the data being turned out by the computer.

The first 20 SEALITE craft will apparently be equipped with the Canadian-built LN-66 search radars which, in later series, will be replaced by the AN/APS-115 set (developed earlier for the P-3C ORION shore-based patrol airplane). The helicopter will also carry a set of 47 AN/SSQ-41 type sonobuoys used in the JULIE and JEZEBEL systems.

The basic ASW armament on the helicopter will be the Mk 46 class homing torpedo.

Paired PT6-T400-CP400 Twin Pack engines having a combined power of 1800 hp will be installed.

Fuel reserves in internal tanks when the craft is used in the ASW configuration equal 540 kg, which gives it a 1.2-hour patrol capability. The fuel in these internal tanks can be increased to 675 kg. Furthermore, two fuel tanks (carrying a total of 250 kg) are suspended on external mounts. With the increased fuel reserve, the craft's patrol period is extended to 3.5 hours. The SEALITE is already being incorporated into the armament of US Navy guided-missile escort ships. [98

In recent years, other American helicopter builders, particularly Hughes and Bell, have been exploring the possibilities of using light, series-produced helicopters within the scope of the LAMPS program under a Navy contract. In the opinion of experts, the Hughes Company's OH-6A CAYUSE and Bell's UH-1N are the most promising for use in ASW operations on the basis of their weight characteristics. Both structurally and in external appearance, the experimental version of the OH-6 for the LAMPS system differs insignificantly from its American predecessor. Its power plant consists of a single T63-A-5A 320-hp turboprop engine. Its rotor blades fold, which substantially decreases its dimensions for shipboard on-deck basing.

The helicopter's armament and on-board gear have been changed. It should be noted that the United States recently turned over to the Spanish Navy five OH-6A craft which had been converted to ASW capability.

According to information in the American Press, the question of the selection of a concrete type of light helicopter for the LAMPS system has not yet been permanently resolved. Main efforts in design and building operations have been aimed at producing the optimal versions of electronic gear and armament, and only after this work has been accomplished will the type of helicopter be selected. Also being worked out is the question of the kind of ships which would be most suitable for use with these helicopters, and what kind of gear they would have to be equipped with. In this connection, the LAMPS has been given another designation: SASI (a program for developing ship and system integration).

Prior to 1970, the British Navy had three obsolescent types of ASW helicopters: the HAS.3 WESSEX, the HAS.7 WIRKLUND (a version of the American S-55), and the HAS.1 WASP. In terms of structural features, on-board gear, and armament, they are of no particular interest.

To replace the WASP, the British--along with the French--developed the WG.13 LYNX light, multi-purpose helicopter. It has been undergoing flight tests since March 1971. Along with the multi-purpose version, an ASW version is being built for the fleet, for use from escort vessels.

The LYNX (figure 5) is being produced in a single-rotor configuration with a four-blade tail rotor and a three-wheel landing gear.

Its power plant consists of two Rolls Royce BS.360-07-26 turbo-prop engines with a maximum power of 900 hp each. Fuel (726 kg) is stored in five fuselage tanks.

The LYNX is equipped with modern search, navigational and communication gear which is lighter, but no more efficient than that of the SEA KING heavy helicopter. For armament it has two Mk 44 torpedoes or depth bombs or type AS.12 wire-guided missiles. The armament is suspended on two mounts (launchers) alongside the fuselage.

The French Navy is equipped with the A-321C SUPER FRELON heavy ASW helicopters (figure 6) which were first used in their units in 1967. They can also be used for minesweeping, minelaying, and assault-troop transport.

The craft's power plant consists of three 111-C6 Turbo turboprop engines with 1500 hp each. It carries a reserve of 3975 liters of fuel in internal tanks. Additional tanks with a capacity of 2000 liters are envisaged. It is equipped for in-flight refuelling. [99]

Its search gear includes towed sonar and a search radar set. For armament it carries four torpedoes, suspended in pairs from mounts along the sides of the fuselage.

For lighter-tonnage ships of the "frigate--escort vessel" type they plan to buy LYNX helicopters from Great Britain in 1972-1973.

The Italian Navy has three types of ASW helicopters: the Agusta Bell 204A, and the Agusta Al06, built in Italy, and the SH-3D SEA KING Agusta Sikorsky, being built on contract.

The 204A Agusta Bell is a modified version of the American IROQUOIS helicopter. It belongs to the class of all-weather craft (top takeoff weight--4300 kg). It has a single 1100-hp T53-11A turbo-prop engine. Its 920 liters of fuel are stored in internal tanks. It is equipped with dipping sonar, the Echo Company's ARJ-5955 search radar, and an automatic flight-control and stabilization system. For armament it has two Mk 44 torpedoes.

The Agusta A106 is the lightest ASW helicopter in the NATO countries (its maximum takeoff weight is 1400 kg). It has a single 330-hp Turboméca-Agusta TAA 230 turboprop engine. Its fuel reserve with auxiliary tanks is 600 liters. Two torpedoes are slung under the fuselage. Production of these helicopters has been terminated.

The SH-3D Agusta-Sikorsky SEA KING does not differ in design or characteristics from the American SH-3D. It carries the AN/APS-182 Doppler navigational radar (according to other sources it carries the AN/APN-195 search radar). There are plans to build 24 such craft.

Thus, at present the basic types of heavy ASW helicopters abroad are the American-built SEA KING, in several modifications, and the French SUPER FRELON. Because they are quite heavy (9000--13,000 kg) and large, they are used primarily from ASW aircraft carriers. There are also plans to use the SEA KING in conjunction with the HARRIER VTOL aircraft from aircraft carriers.

Lighter piloted helicopters with a takeoff weight of no more than 4000--5000 kg are being developed in the USA as part of the LAMPS system for destroyers, escort vessels and frigates. An intermediary step in the program is the conversion of the SEA SPRITE multi-purpose helicopter for the LAMPS system. Experience gained in the use of these converted helicopters with regard to the efficiency of their gear and armament will be used in designing the future light helicopter, which is planned for introduction into service in the mid 1970's.

In Britain and France, the basic light ASW helicopter in the 1970's for escort vessels will be the LYNX, and in Italy it will remain the Agusta Bell 204A and the Agusta A106A.

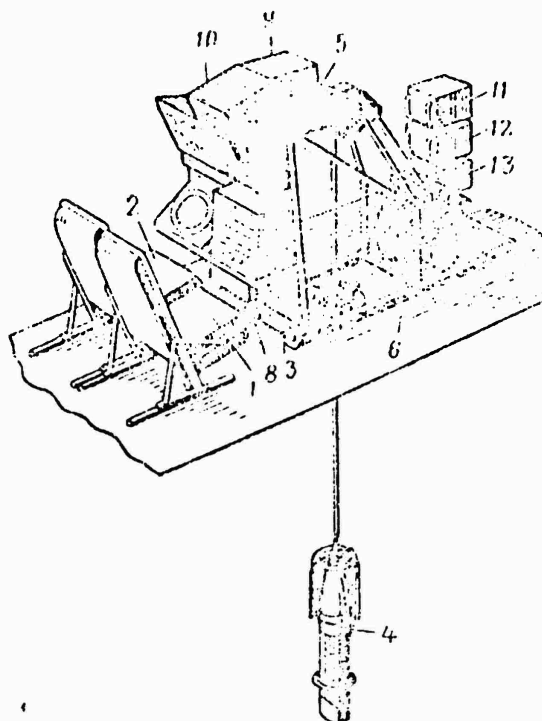

Figure 3: Design of the HAS Mk-1 SEA KING cabin:

1, 2: operators' seats; 3: foot-controlled aircraft intercom; 4: sonar; 5: winch motor foot brake; 9: transmitter unit; 10: Doppler navigational system pulse device; 11: navigational system receiver device; 12: sector scan receiver device; 13: modulator unit.

Figure captions, p. 95, figure 1: The SH-3D ASW helicopter.

figure 2: Arrangement of submarine search and destroyer gear on the SH-3H helicopter:

1, 4: ASW torpedoes; 2, 7: electronic gear; 3: sonar shaft; 5: marker-launching device; 6: dipole reflector launching device; 8: sonobuoy data receiving antenna; 9: sonobuoy launch device; 10: radar search antenna.

figure 4: The SH-2D helicopter of the LAMPS system.

figure 5: The WG.13 LYNX helicopter.

figure 6: The French SUPER FRELON helicopter.



TORPEDO BOATS OF THE NAVIES OF THE CAPITALIST COUNTRIES

During World War II, torpedo boats were widely used in combat [103 operations in closed-sea theaters and in coastal waters. During the post-war period, their construction was temporarily curtailed. It was felt that because with the development of radar detection means, the boats had been deprived of their primary advantage--tactical surprise--and had become extremely vulnerable to automatic guns and shipboard missiles, so that their combat effectiveness would be low.

However, according to many foreign experts, particularly those of Western Europe, because of the broad application of electronic countermeasures and the use of long-range and homing torpedoes, these boats are capable of detecting a target sufficiently in advance for it to close on the enemy to within a range which permits the effective use of torpedo fire. Furthermore, in carrying out missions in skerry regions and in narrows, concealing themselves against the background of the shoreline, they completely retain the advantage of surprise. Equipping such boats with modern navigational gear, electronic equipment, and all-purpose automatic guns along with the improvement in their seakeeping abilities and buoyancy have boosted their combat performance.

The NATO command considers torpedo boats an important integral element in the allied naval forces of the Atlantic Bloc in such regions as the Baltic Sea and its straits zone, as well as the North, Norwegian, and parts of the Mediterranean Seas.

During operational and tactical training in NATO navies, the working out of tactical methods in the use of torpedo boats receives serious attention. These boats operate both independently and jointly with missile-carrying boats and gunboats, other surface ships and attack aircraft. As a rule, torpedo boats attack in groups from various directions, using active and passive radar jamming.

They can perform combat missions such as the torpedoing of combatant ships, using torpedo, guns, and mines; they can operate against sea communications (particularly coastal); and they can cover coastal groupings of ground troops, and carry out reconnaissance.

There are more than 140 torpedo boats of fifteen different classes in the capitalist navies. Scientific research and test design operations are systematically carried out, as in the construction of torpedo boats for their own navies and for export by such well-known

suppliers of the world market in "mosquito fleets" as Great Britain, the FRG, and Norway. The shipbuilding companies of these countries cooperate mutually, and there is a close exchange of plans and finished versions. An increased interest in the building of boats with predominantly torpedo armament has appeared in Italy, Japan, and Sweden. The remaining countries are confined to purchasing series-produced boats or building them in their own shipyards on contract. The absence of torpedo boats in the U.S. Navy is explained primarily by the missions for which that country's navy is destined, the features of the sea theaters in which the American fleet operates, and the fact that America's junior partners in NATO are quite capable of handling the problem of developing boats with primarily torpedo armament.

The foundation of this boat building is the basic model of the British, Norwegian, and West German companies. This is mainly a boat of the BRAVE, NASTY, or JAGUAR class. Several countries have retained American torpedo boats of the HIGGINS class in their navies. It is characteristic that Great Britain and JAPAN, while possessing highly developed shipbuilding industries, do not build large series of the boats for their own navies, restricting themselves to thorough testing of prototypes (in the Japanese Navy, for example, there are 10 torpedo boats of four classes).

The trend toward boosting the power of the torpedo salvo and the effectiveness of its multi-purpose gun armament, to improve the seaworthiness and extend cruising range while retaining the boats' high speed has led to a substantial increase in their displacement. A boat with primarily torpedo armament has a standard displacement of 100--200 tons and a top speed of 50 knots.

The boats' hulls are usually of a composite construction, with a steel (or aluminum alloy) frame and wood plating. The superstructure and bulkheads are of duraluminum. Plastics are widely used.

The boats are armed with four to six 533--mm single-tube, fixed-position torpedo tubes, set at an angle of 6 to 8° to the centerline, which provides for the flight of the torpedo over the deck. The torpedo running and internal system parameters are set synchronously from fire-control instruments continuously as data are processed.

For self-defense, the boats use 40- and 20-mm BOFORS and ERLIKON automatic guns. On boats with mixed armament, after the torpedo tubes are removed the number of gun mounts doubles (by removing two torpedo tubes the boat can carry up to 4 mines). Some gun mounts are coupled with fire-control radar and equipped with a remote control fire-control device, as well as a system for stabilizing the boat with respect to rolling, pitching, and yawing.

In the 1950's, diesel power plants were the most widespread: [104] the high-speed diesels made possible a long cruising range at relatively high speed. After 1960, gas turbines became more commonly used. Their advantages include compactness and a specific weight of 0.5--0.8 kg/hp, their ability to produce substantial power in a single unit--up to 20,000 hp, and their speed in starting up. Their major drawbacks are that they consume a great amount of fuel (up to 70% more than diesels) and are limited to 2000--3000 hours of engine life. The combined diesel-gas turbine engines, which use diesels in the economical cruising mode and switch to gas turbines during afterburner type modes partly eliminate some of these deficiencies. The cruising range of modern torpedo boats is 400-600 miles at speeds of 46--25 knots, respectively.

Because the lifespan of the power plants of such boats is limited anyway, the rapid replacement of parts is envisaged: on the Norwegian TJELD patrol boat (an improved version of the NASTY), for example, it takes only eight hours to replace both diesels.

The propelling agent on the boats are two or three fixed-pitch screws (variable-pitch screws are used on the Swedish torpedo boat SPICA). The screws are two- and three-bladed. Rudders, which are generally of the balanced type--depending on the number of screws, are located abaft them. The rudder driving mechanisms are usually hydraulic, and there is emergency manual control.

Boats of foreign navies widely use dehumidification, water protection, and fire-extinguishing systems. There are plans to make the entire hull water-tight. For improved habitability for the crew, present-day boats are air conditioned. Their seakeeping qualities make it possible to use their guns in sea states up to 4 to 5.

The buoyancy reserve of the boats is 100 to 150%. Their ability to remain afloat when damaged is ensured when two adjoining compartments are flooded.

Great attention is given to the logistical support of these boats. Special tenders are being built (in the FRG for example, there is the RHEIN class). Nonrigid floating plastic tanks are used for refueling at sea.

The following are the numbers of torpedo boats in the respective navies today: FRG--40; Sweden--32; Norway--20; Denmark--16; Greece--13; Italy--12; Turkey--12; Japan--10; Great Britain--2. These figures include boats with mixed armament.

TACTICAL AND TECHNICAL DATA OF THE BASIC CLASSES OF TORPEDO BOATS

Country, Class, No., Year of entry into service	Displacement: standard full, t	Dimensions: length, beam draft, (m)	Speed (knots)	Armament		Comple- ment
				Torpedoes: no., calib. (mm)	Auto. weapons no., calib. (mm)	
Great Britain						
BRAVE--2, 1960	$\frac{89}{114}$	29.9 7.8 1.9	52	4-533 or 2-533	1-40 2-40	20
Denmark						
SOLOVEN--6, 1964-1927 (British-built)	$\frac{95}{114}$	30.2 7.8 2.1	54	4-533	2-40 Bofors	29
FALKEN--4, 1962-1963	$\frac{119}{119}$	36.0 5.4 1.8	40	4-533	1-40 1-20	23
Italy						
MS441--3 (American HIGGINS)	$\frac{64}{64}$	23.8 6.1 1.8	34	2-450	1-40 2-20	15
LAMPO--2, 1961-1962	$\frac{170}{190}$	40.0 6.4 1.5	40	2-533	1-40	.

Country, Class, No., Year of entry into service	Displacement: standard full, t	Dimensions: length, beam draft, (m)	Speed (knots)	Armament		Comple- ment
				Torpedoes: no., calib. (mm)	Auto. weapons no., calib. (mm)	
Norway						
TJEID (improved NASTY)-- 20, 1960-1965	70 82	29.5 7.8 2.0	45	4-533	1-40 1-20	22
FRG						
JAGUAR--40, 1957-1963	160 190	42.1 6.7 1.5	42	4-533 4 mines instead of 2 torp.tubes	2x1-40 Bofors	38
Sweden						
SPICA--6, 1968	190-230	43.0-45.0 7.1	40	6-533	1-57 Bofors	28
Pleid--11, (built in FRG). 1954-1958	155 170	48.0 5.6 1.6	37.5	6-533	2x1-40	33
Japan						
PT-10--1, 1962	90 120	32.0 8.4 1.1	48	4-533	2x1-40	26

CHANGES IN THE BREADTH OF THE TERRITORIAL
SEA OF GABON AND CAMEROON

by V. Minin

A little more than a year ago (Morskoy sbornik No. 4, 1970, re- [107
ported on this) Gabon established a breadth of 25 miles for her
territorial sea. In accordance with decree No. 1 (72) of 5 January
1972, the government of the country has increased the breadth of the
territorial sea to 30 miles. Its breadth is measured from the mean
low water line.

Thus, three African countries--Nigeria, the People's Republic of
the Congo, and Gabon--have a territorial sea with a 30 mile breadth.

On 3 November 1967 Cameroon increased her territorial sea from
six to 18 miles, measured from the mean low water line.

Now by decree of the president of the United Republic of Cameroon
No. 71(DF)416 of 26 August 1971, lines are established from which the
territorial sea in straits, bays, and harbors is measured. These lines
are (from north to south): the harbor in the Akwayafe River delta--
straight lines connecting Bakasi, Anley, Sandy, and East Points; the
harbor in the Rio del Rey River delta--a straight line from Cape Bakasi
to Betika Cape; Bibundi Bay--a straight line from Madale Point to Cape
Debundga; Ambas Bay--straight lines connecting Limbon Point, the South
Point of Ambas Island, and Cape Nachtigal; Naval Ships (Navire de Guerre)
Bay--a straight line from Cape Nachtigal to Cape Bimbia; the harbor in
the Bimbia River mouth--a straight line from Cape Bimbia to the point
of intersection of the shore with the meridian 9° 21' 40" East Long.;
and the harbor in the mouth of the Wuri River--a straight line connect-
ing the above indicated point with Suelaba Point.