

AD-757 425

ADVANCED OCEAN ENGINEERING LABORATORY
TECHNICAL PROGRESS REPORT

William A. Nierenberg, et al

Scripps Institution of Oceanography

Prepared for:

Office of Naval Research
Advanced Research Projects Agency

14 February 1973

DISTRIBUTED BY:

NTIS

National Technical Information Service
U. S. DEPARTMENT OF COMMERCE
5285 Port Royal Road, Springfield Va. 22151

AD 757425

SCRIPPS INSTITUTION OF OCEANOGRAPHY
UNIVERSITY OF CALIFORNIA, SAN DIEGO
Dr. William A. Nierenberg, Director
Principal Investigator
ADVANCED OCEAN ENGINEERING LABORATORY

Technical Progress Report

December 31, 1972

Sponsored by
ADVANCED RESEARCH PROJECTS AGENCY
ARPA Order Number 2185
Program Code 1N10



Administered by the OFFICE OF NAVAL RESEARCH
Contract N00014-69-A-0200-6039
Contract Effective Date: April 1, 1972
Contract Expiration Date: December 31, 1972
Total Contract Amount \$805,000.00

Reproduced by
NATIONAL TECHNICAL
INFORMATION SERVICE
U S Department of Commerce
Springfield VA 22151

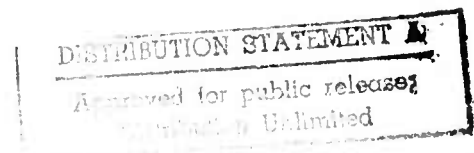

SIO Reference Number 73-3

AOEL Report #35

Unclassified

Security Classification

DOCUMENT CONTROL DATA - R & D

(Security classification of title, body of abstract and indexing annotation must be entered when the overall report is classified)

1. ORIGINATING ACTIVITY (Corporate author) The Regents of the University of California University of California, San Diego La Jolla, California 92037		2a. REPORT SECURITY CLASSIFICATION Unclassified	
		2b. GROUP Not Applicable	
3. REPORT TITLE Technical Progress Report Advanced Ocean Engineering Laboratory			
4. DESCRIPTIVE NOTES (Type of report and inclusive dates) April 1, 1972 to December 31, 1972			
5. AUTHOR(S) (First name, middle initial, last name) Dr. William A. Nierenberg Dr. Charles S. Cox Dr. Carl A. Friehe Dr. Walter H. Munk Dr. Michael C. Gregg Dr. F. H. Champagne Dr. Frank E. Snodgrass Dr. Carl H. Gibson			
6. REPORT DATE February 14, 1973		7a. TOTAL NO. OF PAGES 51	7b. NO. OF REFS 7
8a. CONTRACT OR GRANT NO. N00014-69-A-0200-6039		9a. ORIGINATOR'S REPORT NUMBER(S) SIO Reference No. 73-3	
b. PROJECT NO.		9b. OTHER REPORT NO(S) (Any other numbers that may be assigned this report) AOEL Report No. 35	
c.			
d.			
10. DISTRIBUTION STATEMENT Distribution of this document is unlimited			
11. SUPPLEMENTARY NOTES		12. SPONSORING MILITARY ACTIVITY Advanced Research Projects Agency c/o Office of Naval Research Arlington, Virginia	
13. ABSTRACT This semi-annual report reflects the technical status of internal/ surface wave interaction and microstructure projects conducted within the Advanced Ocean Engineering Laboratory at the Scripps Institution of Oceanography. These projects are: (1) Thermal Microstructure - to examine in detail the structure and dynamics of temperature and salinity and (2) Atmospheric Boundary Layer - to provide an understanding of the interaction between atmospheric boundary effects and surface waves.			

14 KEY WORDS	LINK A		LINK B		LINK C	
	ROLE	WT	ROLE	WT	ROLE	WT
Advanced Ocean Engineering Laboratory Thermal Microstructure Vertical fluctuations in temperature and salinity Microstructure recorder Shear instabilities Small-scale convection motions Isotropy of the microstructure Freely floating instrumented capsule Internal waves Buoyancy control system Atmospheric Boundary Layer Anemometer Large scale velocity measurements Traversing boom Instrumentation recorder Turbulent wind field Inertial Navigation System Surface waves Sea-Surface temperature						

Disclaimer

The views and conclusions contained in this document are those of the authors and should not be interpreted as necessarily representing the official policies, either expressed or implied, of the Advanced Research Projects Agency or the U. S. Government.

Advanced Ocean Engineering Laboratory

Technical Progress Report

Table of Contents

Thermal Microstructure	Part I
Thermal Microstructure	Part II
Atmospheric Boundary Layer	Part I
Atmospheric Boundary Layer	Part II

Thermal Microstructure

Part I

Co-Principal Investigators
Drs. Charles S. Cox and Michael C. Gregg
Phone (714) 453-2000, Extensions 1159 and 2885

Advanced Ocean Engineering Laboratory

sponsored by

Advanced Research Projects Agency

ONR Contract N00014-69-A-0200-6039

I Summary

This report summarizes the work undertaken since receipt of the contract in April 1972. Since this represents just 9 months of a projected 3 year study, part of our effort has been the development of hardware and computer programs. However, in doing so, some results of considerable interest have been obtained.

II Technical Report

We are attempting to measure the smallest scales of variability in the ocean and from these observations, to deduce what physical processes are important in forming this microstructure activity. Our present instrumentation senses vertical fluctuations in temperature and salinity to scales of approximately 1 cm. In some regions we have found that this is sufficient to resolve all of the significant temperature fluctuations. Other more active places may require a resolution of a few millimeters. To obtain a more complete picture of the structures in the water column, a temperature probe is mounted on the tip of one of the wing blades of the microstructure recorder (MSR). This sensor traces out a helical path as the instrument falls vertically. By comparing this signal with the record from the nose probe mounted on the axis of the MSR, we can determine the 3-dimensional character of the small structures in the water. Toward this end we have had the following activities:

- a) To determine representative levels of microstructure activity in various oceanic regions. From July through September, we participated in a cruise to the Equator, the South Pacific and Peru Current, which gave us the opportunity to take extensive measurements in regions where none have been made previously. Although most of this work was funded by ONR, contract funds were used to augment the scope of this effort.
- b) To compare the levels of microstructure activity in different locations and the processes which are responsible. Visual inspection of records from the California Current have shown the signatures of two physical processes which generate microstructure activity: shear instabilities and small-scale convection motions resulting from the different diffusivities of heat and salt. These two phenomena seem to be responsible for the high levels of microstructure near shore. By contrast, the analysis of data from the mid-Pacific has just been completed and shows much lower levels of activity. In the microstructure range spectral levels of the temperature gradient are a factor of 50 below those nearer shore

at the same depth. In keeping with this, the wing probe has shown that the approach to isotropy occurs at smaller scales in the mid-Pacific data (see the Appendix for a more complete discussion of this point).

From the analysis of previous data we have found several aspects of our work that need more development. The majority of our ARPA related work has been devoted to these improvements:

1. Obtaining good data from a remote location, such as the mid-Pacific, requires that the data be read and at least partially analyzed on board immediately after the record is obtained. Our NOVA mini-computer system has been upgraded by the purchase of a model with increased core and by the addition of several peripheral items such as a disk and plotter. These will allow us to do spectral analysis on the data at sea. We have also placed an order to purchase a separate van to house the computer on deck. Previously the computer was housed in the van used to service the MSR instrumentation. The high access into this van can result in high humidity in tropical regions. This past summer the computer was rendered inoperative for one leg of the cruise by this problem.
2. Obtaining a more complete picture of the processes generating microstructure requires that we perform multiple experiments simultaneously. A new MSR with twice as many data channels has been designed and is under construction. One feature of this new instrument is a continuous measurement of the tilt of the vehicle as it descends. This is essential to a determination of the 3-dimensional structures from the wing records.
3. Obtaining greater resolution in the temperature measurements requires thermistors with a faster transient response. Calculations are being done to determine the optimum configuration for a flake thermistor. A facility to test the calibration of these flakes has been designed. Part of the upgrading of the computer system has been to handle the greater dynamic range of these thermistors.
4. In the past we have chosen only sections of our data records for analysis. To obtain better statistics we are now attempting to analyze all of the data which is acquired. A considerable effort has been spent on this during the past 9 months.

III Reports Prepared

The analysis of data from the San Diego Trough and the Mid-Pacific has been completed during this period. The work is being prepared for publication and should be available for distribution in the near future.

IV Appendix

Isotropy of the Microstructure

A crude indication of the 3-dimensional character of the temperature fluctuations can be obtained by inspecting the wing and nose records visually. Figure 1 shows a record from 320-370 m in the central North Pacific. Very little difference in levels of activity is evident in these plots, indicating that the structures are primarily horizontal. A more quantitative estimate of this is had by comparing the spectra of the wing and nose probes, as shown schematically in Figure 2. From this it is seen that if both probes can resolve temperature fluctuations to the diffusive cut-off, it is possible to determine whether the microstructure spectra represent: completely horizontal structures, patches of isotropic structures, or patches with fine scale layering.

Unfortunately, even though the nose probe resolved most of the temperature fluctuations, the wing - due to its greater velocity through the water - did not. As seen by the data in Figure 3, the wing cuts off between 4 - 7 cycles/meter. At these wavenumbers there is almost no indication of an approach to isotropy. Even if the noise is included, the wing spectra at 10 cycle/meter are a factor of 3 below the levels of the nose. This is in marked contrast to the situation near shore where the nose and wing spectra have about the same levels at 10 cycles/meter. However, it must be noted that these spectra are averages over 50 to 100 m intervals. The high wing values near shore can result from only one intense patch of microstructure activity extending vertically for 1 m. The remainder of the water column may be well stratified at these wavenumbers. In the mid-Pacific such patches are apparently much less frequent than near shore.

FIGURES

- Figure 1 - The temperature fluctuations seen by wing and nose probes are shown with the impulse response curves of both circuits. Since the Y axis of both records is plotted against time, the ordinate scale of the nose probe represents vertical distance while that of the wing signifies distance along its helical path. The full length of the arrow on the nose plot represents 10 m while that of the wing indicates 100 m. The wing plot has been off-set vertically, so that matching features are seen at the same level.
- Figure 2 - Schematic of relative wing and nose spectra for different structures in the water. If both probes fully resolve to the diffusive cut-off, then it is possible to distinguish between these simple patterns. However, the cut-off of the wing at a lower wavenumber than the nose renders the interpretation ambiguous.
- Figure 3 - Spectra for the wing and nose from the mid-Pacific. The spectra have been averaged over the length of record indicated in the figures. The wavenumbers are computed for the actual path travelled by the respective probes. Solid lines show the spectra corrected for thermistor response, the dotted lines lack this correction. The open symbols at the high wavenumber end of the wing spectra show where the spectra are noise dominated.

NOSE

$\Delta\theta = 5 \times 10^{-3} \text{C}$
Calibration
Pulse

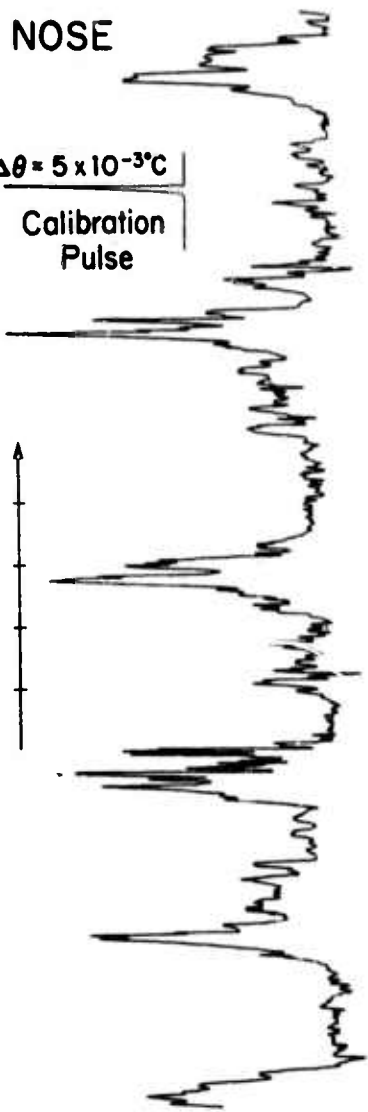

WING

$\Delta\theta = 5 \times 10^{-3} \text{C}$
Calibration
Pulse

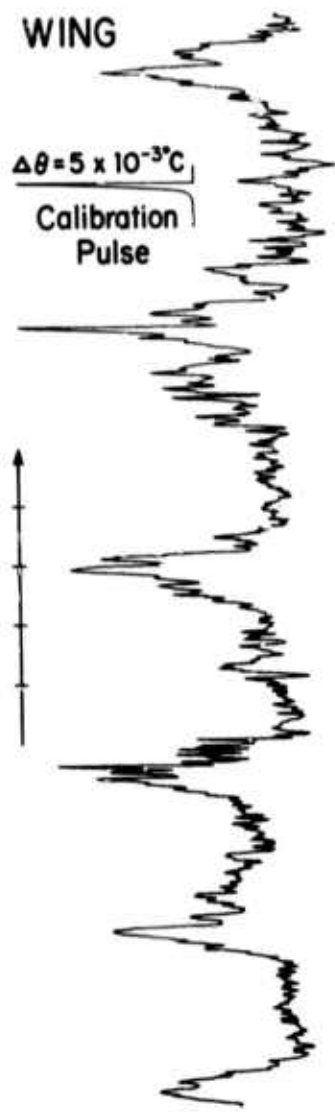

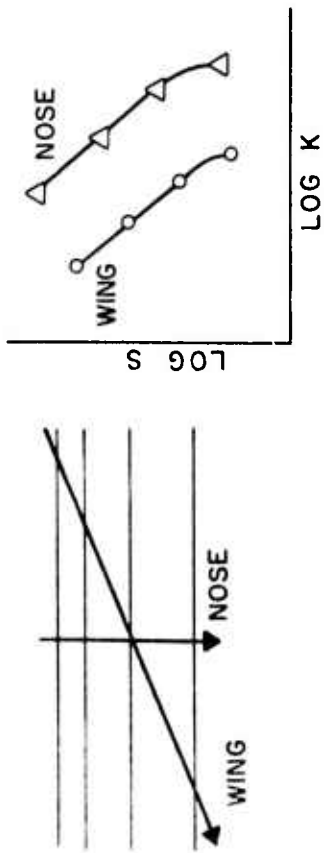

COMPLETELY STRATIFIED

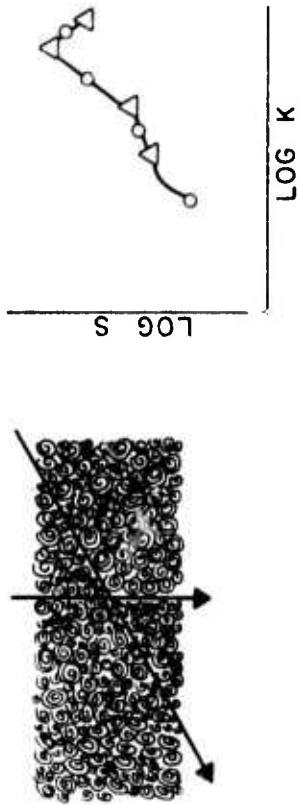

ISOTROPIC TURBULENCE

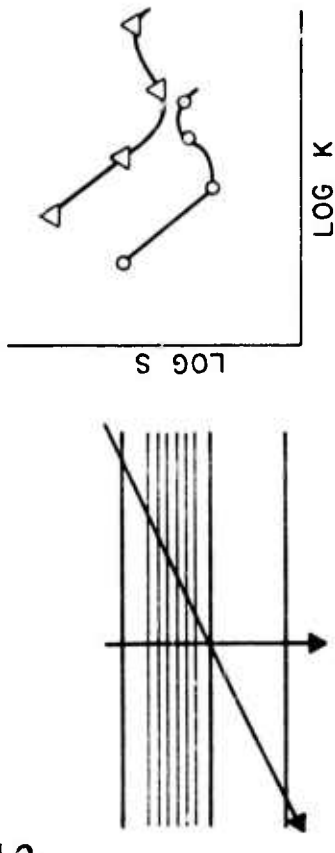

STRATIFIED WITH UNIFORMLY SPACED FINE STRUCTURE

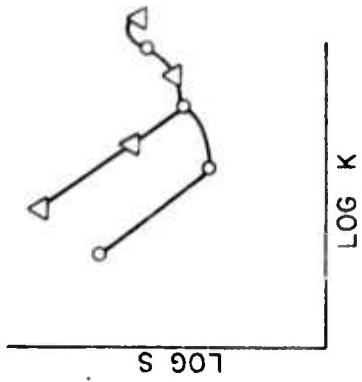

STRATIFIED WITH A TURBULENT LAYER

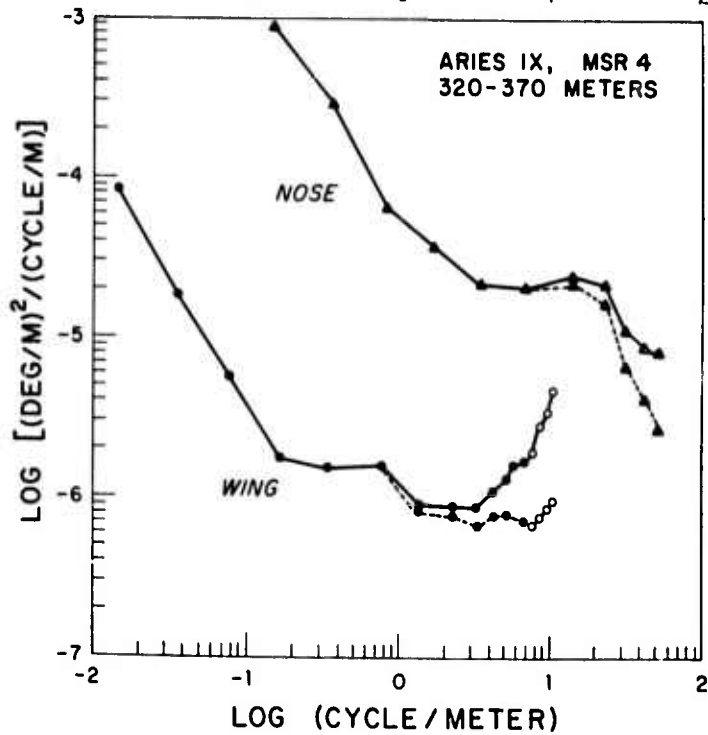
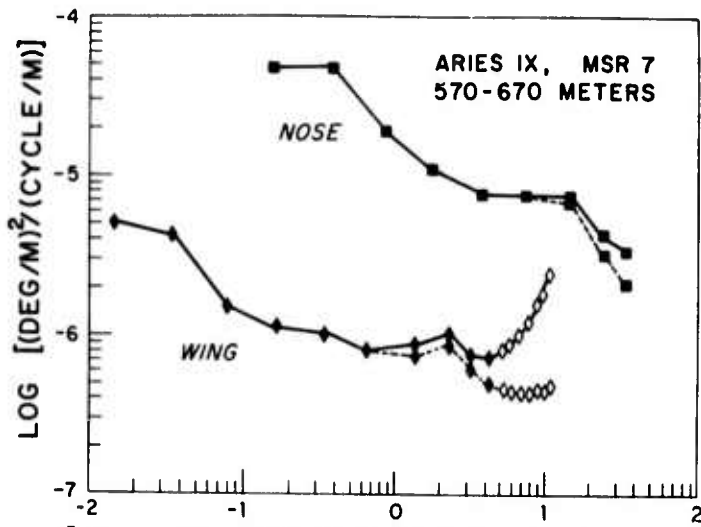

Thermal Microstructure

Part II

Co-Principal Investigators
Drs. Walter H. Munk and Frank E. Snodgrass
Phone (714) 453-2000, Extensions 1741 and 1740

Advanced Ocean Engineering Laboratory

sponsored by

Advanced Research Projects Agency

ONR Contract N00014-69-A-0200-6039

Thermal Microstructure

Part II

Table of Contents

1. Purpose of Project
2. Accomplishments
3. Future Plans
4. Summary

List of Figures

Figure i. Typical Instrument Capsule Configuration

Purpose of Project

The purpose of this project is to examine in detail the history of thermal structure within \approx 10 0meter vertical segments of the water column. The data is gathered by a freely floating instrumented capsule programmed to oscillate vertically about a chosen midwater depth (Fig. 1). The capsule is a modification of one previously developed for bottom-mounted deep-sea tide measurements.¹

The analysis of the resulting thermal history will concentrate on:

- 1) spectra and vertical coherence of internal waves,
- 2) time evolution of thermal microstructure including the equilibrium between generation and destruction, and
- 3) interaction of internal waves and microstructure.

The measurements and subsequent analysis are to yield information on the following:

- 1) the distribution pattern of surface strains induced by naturally occurring internal waves,
- 2) the statistical distribution of shear instabilities in the interior, presumably with a resulting temporary, local destruction of microstructure, and
- 3) the subsequent formation of new micro-layers.

The work under (1) can be correlated to measurements of electromagnetic energy scattered from a roughened surface; those under (2) and (3) to experiments involving acoustic backscatter.

Accomplishments

During the period under consideration the primary emphasis has been on equipment development and procurement. Three sea trips in the Southern California offshore area have been made for equipment evaluation and preliminary data acquisition as follows:

- 1) August - On this trip four capsule drops of one day duration each were made to a depth of one kilometer. Data was obtained on the capsule response to internal waves and on amplitudes of internal waves at this depth. This data has guided further development of the buoyancy control system. These drops also revealed a depth dependent gas loss problem associated with the operation of the buoyancy control system. Due to the gas loss, the capsule did not oscillate as programmed about the chosen operating depth.

1. Snodgrass, Frank E. (1968) Deep Sea Instrument Capsule, *Science*, 162, 78-87.

- 2) September - On this trip a new high speed data-logging system, under continuing development on this contract, and a new commercially obtained high speed, large tape-capacity digital tape recorder were tested. Gas loss tests were also made of the modified buoyancy control system. The back-up, shipboard acoustic data-link from the capsule allowed verification of proper operation of the modified buoyancy control system. The new digital tape recorder failed, however, so no data on the high speed data-logging system was obtained.
- 3) November - On this trip a four day capsule drop was made to obtain internal wave time series in conjunction with related measurements made simultaneously from the research vessel FLIP. These measurements had to be made with the buoyancy control system inactivated because of problems with the control logic. The buoyancy control system logic problems were corrected after completion of the measurements. On two subsequent drops on this trip first tests were made of microstructure sensors and associated electronics developed under this contract. Tilt-metering of the sensor mounting arms was also tested. Although the acoustic data-link again provided limited data, the tape recorder, having been reworked by the manufacturer, malfunctioned once more. We are still working on recovery of data from the faulty tapes, though recovery of data on magnetic tape from this trip is questionable.

Future Plans

Equipment development will be completed. High on the list is modification of the tape recorder, in coordination with the manufacturer, to increase its reliability. It will also be intensively tested prior to the next sea trip. We are developing an at-sea tape reading capability and a test-pattern generator to fully test tape recorder functioning both before and after each capsule launch. A compass system is being added to the microstructure sensing package to monitor the azimuthal orientation of the sensor mounting arms.

This remaining equipment development work can be expected to be completed by the end of March. We then plan a series of sea trips tentatively scheduled as follows:

- April - One week in nearest deep water for final equipment evaluation and gathering of preliminary data.
- June - Two weeks in conjunction with FLIP offshore for data gathering.

October - Three weeks in conjunction with FLIP north of Hawaii for data gathering.

Summary

Development is nearly complete of a midwater instrumented capsule. The capsule will be capable of making detailed measurements of thermal structure history of 100 m segments of the water column to a maximum operating depth of one kilometer. Initial sea trials have yielded engineering data and preliminary geophysical data. In the coming year one additional engineering sea trip will be followed by two data-gathering sea trips in conjunction with the research vessel FLIP.

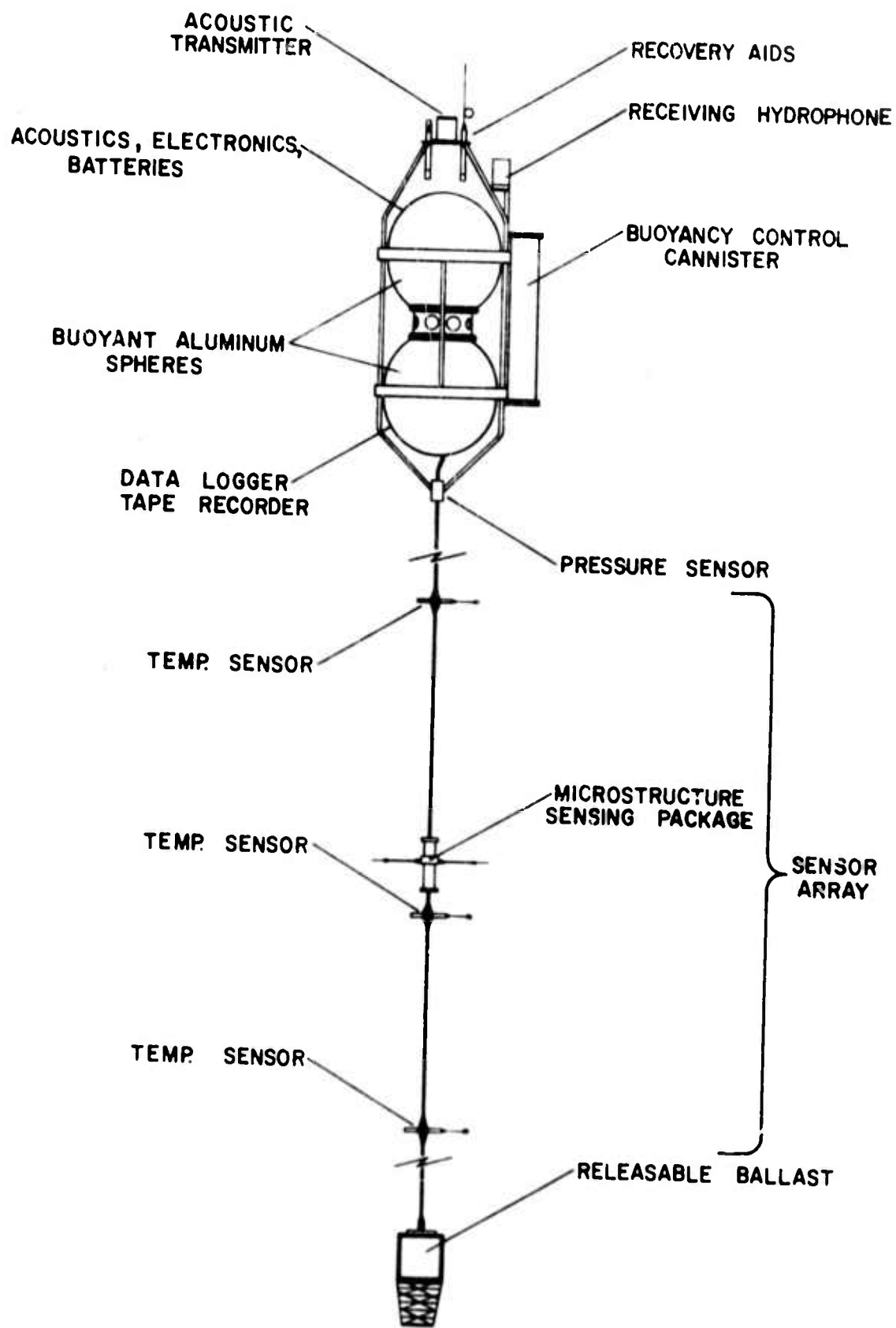

TYPICAL INSTRUMENT CAPSULE CONFIGURATION

Figure 1.

Atmospheric Boundary Layer

Part II

Co-Principal Investigators

Drs. Carl H. Gibson, Carl A. Friehe and Francis H. Champagne
Phone (714) 453-2000, Extensions 1662, 2634 and 1653

Advanced Ocean Engineering Laboratory

sponsored by

Advanced Research Projects Agency

ONR Contract N00014-69-A-0200-6039

Atmospheric Boundary Layer

Part II

Table of Contents

1. Introduction
2. Primary Projects
 - A. Open Ocean Experiment, April, 1972
 - B. OWEX, November, 1972
 - C. Important Equipment Purchased and Developed
3. Analysis

List of Figures

- Figure 1. MITOS 3 Tape 2, U and W Spectra
Figure 2. MITOS 3 Tape 2, Isotropy Test, Ratio of
Wand U Spectra
Figure 3. M3D4. UW and UW(UNC) Co-Spectra
Figure 4. M3D4 Gyro File 6, DEG

Introduction

Understanding and isolating the effects of internal waves on surface waves also requires an understanding and isolation of all other phenomenon which affect the surface waves. The primary source of surface waves is the turbulent wind field. The mechanism of wind-wave generation remains a central unsolved problem of air-sea interaction. With R. E. Davis of SIO we have made attempts in the past to acquire basic near-surface turbulence and wave data over the open ocean. Those early experiments demonstrated that near surface turbulence and surface wave measurements were possible, although some problem areas were found. Our efforts during the contract period April 1 to December 31, 1972, were primarily concerned with correcting those problems as described below. We participated in the ARPA FLIP operation OWEX by developing an instrumentation system to measure environmental variables of interest to the radar/internal wave program. We also purchased and developed instrumentation for a FLIP experiment scheduled for March, 1973. An outline of the experimental plan is attached as an Appendix.

Primary Projects

A. Open Ocean Experiment, April, 1972

In April 1972, a cruise was made on FLIP (operation MITOS 3) partly supported by ARPA to solve the following problems:

1. Improve the measurement of the instantaneous turbulent velocity components required for calculation of the momentum transfer between the air and sea surface.
2. With the vertical gyro system developed by R. E. Davis of SIO, measure the pitch component of FLIP's motion and correct measured vertical velocity data for this motion.

Previous to the April experiment, our attempts at precise measurement of two components of the velocity field with X-hot wire anemometers often failed. Difficult calibration of the X-wire probes in the FLIP laboratory and subsequent drift of the probe calibration in the wind field due to contamination of the hot-wires by salt spray were the primary error sources. For the April cruise, we were able to borrow an EG&G three-component sonic anemometer from Rome Air Development Center for evaluation. The operation of this device is based on the principle of the Doppler-shift of sound waves by wind velocity in the measuring paths. Three paths are used to measure the three components of instantaneous turbulent velocity vector, over a bandwidth from d.c. to 10 Hz. In addition to measuring all three components simultaneously, the instrument is an absolute device, and does not require calibration at the field site. We also tested the cylindrical hot-film type of high frequency anemometer sensor

to determine if it is less susceptible to salt spray contamination than standard hot-wire sensors. The hot-film sensors consist of a 0.001" quartz cylinder over which is plated a platinum film 0.020" long with gold leads at each end. The surface is sputtered with quartz to help protect the platinum film from particle contamination in the air stream. Such a coating process is not available for the standard 0.00015" diameter tungsten hot-wires normally used for turbulence measurements in laboratory experiments.

On the FLIP, the sonic anemometer, hot-film anemometer and vertical gyro were placed on an instrument mount at the end of the then new 60' port boom. The vertical gyro was calibrated in the laboratory at La Jolla, and mounted so that its axis was exactly parallel to the vertical axis of the sonic anemometer. From the recorded signals we were able to correct (during digital analysis) the pitch sensitive vertical velocity sonic anemometer signal for the instantaneous pitch angle of the instrument package at the end of the boom. Unfortunately, a portion of the EG&G circuitry failed, so that we were not able to obtain sonic anemometer signals of horizontal and transverse velocities. For the horizontal velocity measurements we used the hot-film sensor with a constant temperature anemometer (response d.c. to several KHz). With the new type of sensor, drift was greatly reduced.

Partial results of one set of data obtained during the April cruise are summarized in Table 1.

Table I

<u>Variable</u>	<u>W Corrected for Pitch of FLIP</u>	<u>W Uncorrected</u>	<u>Inertial Dissipation Technique</u>
\overline{U} , cm/sec	677	same	-
\overline{W} , cm/sec	36	54	-
rms, W, cm/sec	29	28	-
\overline{UW} , cm ² /sec	-323	-208	-400
\overline{WT} , °C cm/sec	1.1	1.0	1.0
\overline{WQ} , μgm water/cm ² sec	2.1	2.3	1.7

where

U = horizontal velocity component

W = vertical velocity component

T = temperature

Q = humidity

and the overbar symbolizes a time average (2½ hours).

Of primary interest are the values of the three covariances \overline{UW} , \overline{WT} and \overline{WQ} in the atmospheric boundary layer, for these are directly proportional to the shear stress, sensible heat flux and latent heat flux, respectively, at the air-sea interface. For surface wave generation, the shear stress is important, while the heat fluxes and shear stress values determine the effects of buoyancy on the turbulent field in the boundary layer. Correction of the instantaneous vertical velocity signal for the pitch motion of FLIP has a large effect (~ 50%) on the magnitude of the measured shear stress. The magnitudes of the other variables calculated are less-sensitive to the W correction. In the third column of Table 1 are estimates of the covariances obtained from high frequency spectral analysis of the U, T and Q time series (see Stegen, Gibson, Friehe, J. Phys. Ocean., 1973, for details of this method). The high frequency fluctuations should not be affected by FLIP's low frequency motion. The comparison between

the directly calculated covariances corrected for motion and the high frequency estimates are reasonably good for this case.

Low frequency spectral analysis of the U, W, T, Q and pitch angle time series was also obtained. Figure 1 shows the power spectra of the U and W velocity components (plotted with the ordinate of frequency time power spectral density versus "reduced frequency" which is the frequency in Hertz, N, times the mean height above the surface, Z = 12 meters, divided by the mean wind speed, \bar{U}). The spectra have certain characteristics which lend support to the validity of the U and W measurements: at low frequencies ($f < \sim 0.1$), the W spectrum is attenuated below the U spectrum; at high frequencies both spectra exhibit a slope of approximately $-2/3$, which is the value on this type of plot for the Kolmogoroff inertial subrange. Also, at high frequencies, the W spectral level is greater than the U spectral level; Figure 2 shows the ratio of the two spectral levels versus frequency. For $f > \sim 0.05$, the ratio is close to $4/3$, the value predicted by theory for the case of isotropic turbulence. Knowledge of isotropy of the turbulent field at these frequencies may be an important input to development of theoretical models. Figure 3 shows the UW co-spectrum for the two cases of the W signal corrected and uncorrected for FLIP pitch. The primary effect appears to be at about 0.1 Hz, approximately the wave swell frequency. The pitch motion spectrum is shown in Fig. 4 where there are two domination modes at about .015 Hz (close to the resonant frequency of FLIP) and at the wave-induced frequency of 0.1 Hz. Although these results are encouraging, it is recognized that only part of the FLIP-induced motion has been accounted for. With more instrumentation we will attempt to determine the effect of all components of FLIP's motion on the velocity field measurements and consequently be able to isolate wave-induced effects from FLIP-induced effects.

B. OWEX, November 1972

Our participation in the November FLIP operation OWEX was to provide micrometeorological instrumentation. The instrumentation consisted of:

1. Teledyne-Geotech precision cup anemometer.
2. Teledyne-Geotech precision wind-direction vane.
3. Hewlett-Packard quartz thermometer system with:
 - a) a spirated, radiation shielded, mean air temperature probe; b) mean sea-surface temperature probe mounted on a float.
4. Thermo-Systems, Inc., hot-film anemometer system, for turbulence data.
5. Thermistor probes to measure fluctuating air temperature.

6. We also tested and calibrated the vertical gyroscope system developed by R. E. Davis of SIO for measurement of FLIP's pitch and roll fluctuations.
7. Compass angle of FLIP was obtained from the ship's gyro-repeater potentiometer pick-off.
8. Tape recorder calibrating system.

The micrometeorological instrumentation was mounted approximately 20 feet from the hull on the port boom. The gyroscope system was placed in an instrumentation rack in the electronics laboratory area of FLIP.

Personnel from Stanford Research Institute were instructed in the operation of the above instruments for the FLIP operation OWEX. C. Friehe participated in the pre-OWEX trial experiment to instruct the SRI technician in setting up the instruments after FLIP was in the vertical position. The above data, and data from other experiments, was recorded on two rented 14-channel Honeywell portable FM tape recorders. Although we believed these units were reliable, there were malfunctions causing some loss of data. Some data was also recorded on a 3-channel strip chart system, and FLIP's two-channel strip chart recorder. The only total instrument failure was the loss of the small UCSD battery-powered thermistor probe circuit; however, a simple replacement d.c. amplifier system was described to the SRI technician over the radio-telephone, and was put together on board FLIP. SRI is presently reducing the above data.

C. Important Equipment Purchased and Developed

The major scientific instruments purchased were an EG&G three-dimensional sonic anemometer array, a DISA constant temperature anemometer system, a 14-channel Honeywell tape recorder, and a precision quartz thermometer. The sonic anemometer is the best device available for absolute, simultaneous measurement at low-frequencies (0-10 Hz) of the three components of the turbulent velocity vector in air. Particularly advantageous is the fact that the device does not require calibration in a flow of known velocity. We have designed and developed our own sonic anemometer read-out system, rather than purchase the expensive commercial version. For high frequency turbulence measurements (to at least 5 KHz), however, hot-wire or hot-film anemometry instrumentation is required, and we have purchased DISA constant anemometer equipment to add to our existing DISA instruments to provide the capability of two-component simultaneous velocity measurement. The anemometer probes require calibration in a flow of known velocity, and a MKS Baratron pressure transducer system was purchased to accurately measure the pressure corresponding to the exit velocity of a calibration jet facility operated in the FLIP laboratory. Our data-recording system was greatly improved by the acquisition of a Honeywell 14-channel FM instrumentation tape recorder. An extensive survey

of available machines was made, before choosing the Honeywell, with criteria being signal-to-noise ratio, low tape speed flutter, least tape wear and proven reliability. A Hewlett-Packard two-channel quartz probe thermometer system was purchased for precision measurement of sea-surface and mean air temperature. In December, we acquired, through ARPA, a used Litton Industries LTN-51 Inertial Navigation system. This device contains an inertial reference platform with precision gyroscopes and accelerometers with which we plan to accurately measure all components of FLIP's motion.

Other supporting equipment purchased included a storage-type oscilloscope, amplifiers, a time-integrating digital voltmeter, and precision calibration voltage supplies. The above equipment will be operational for the March 1973 FLIP operation.

FIGURE 1

MITOS 3 TAPE2, U AND W SPECTRA

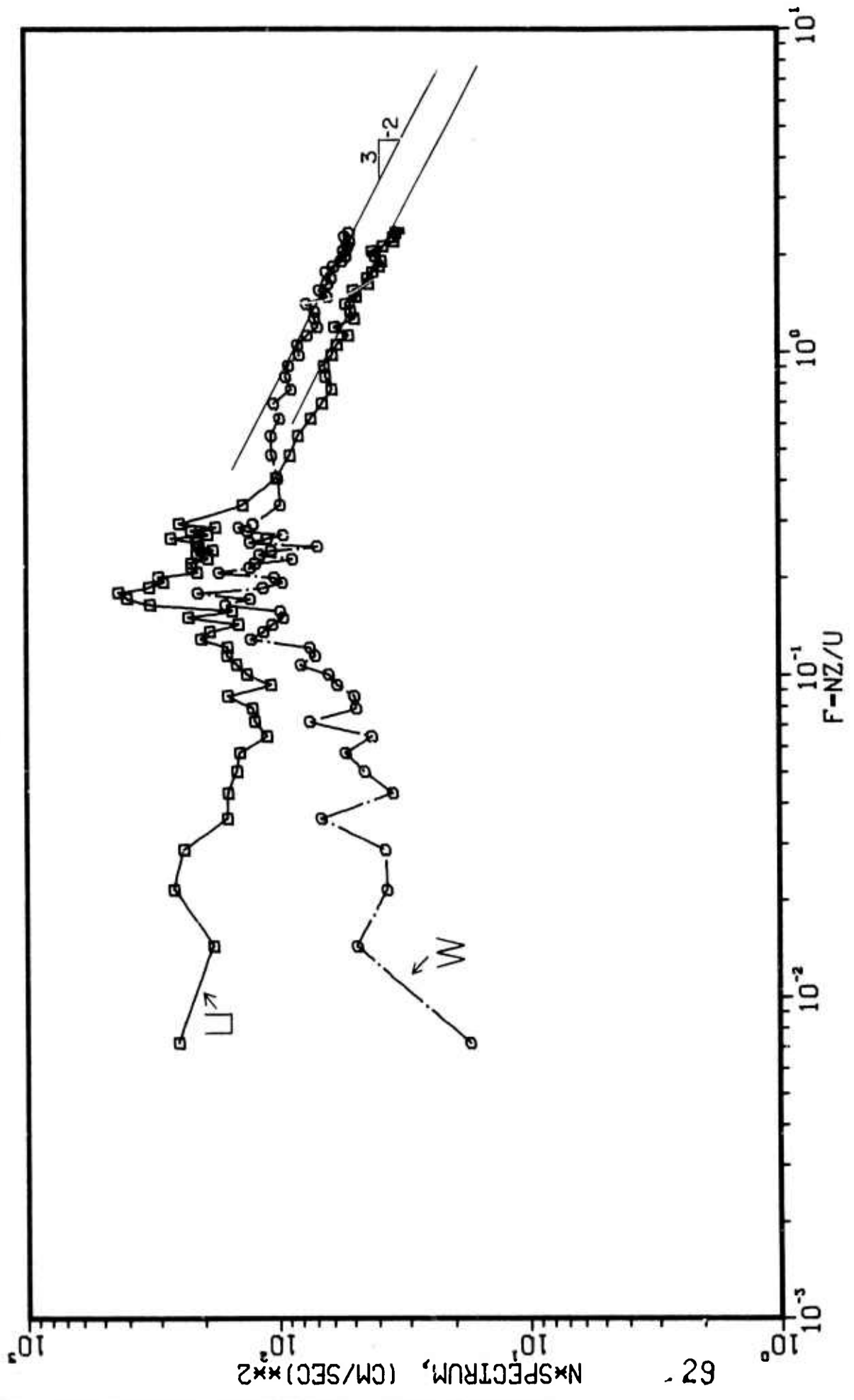

FIGURE 2

MITOS 3 TAPE 2, ISOTROPY TEST, RATIO OF W AND U SPECTRA

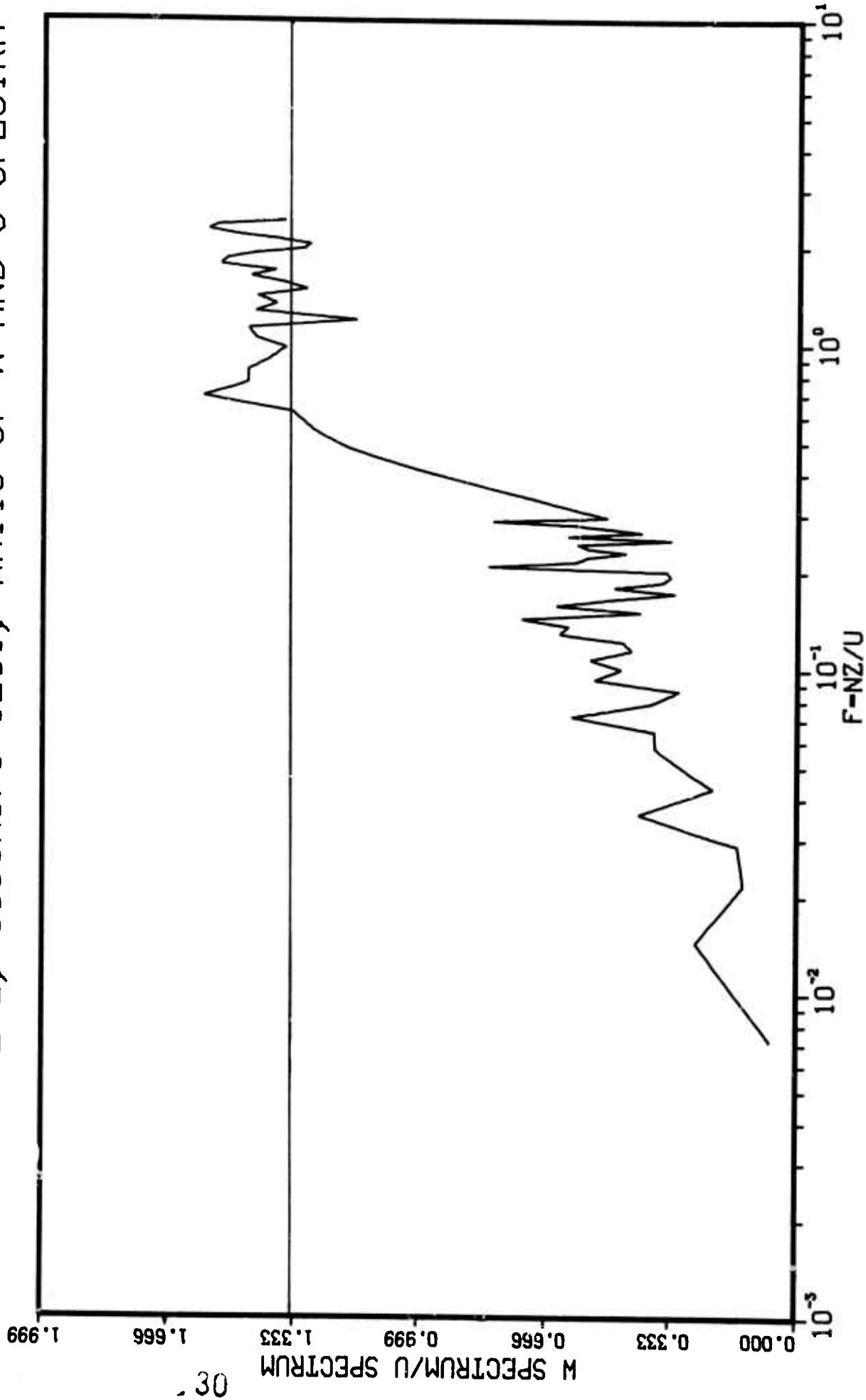

FIGURE 3

M3D4, \overline{UW} AND $\overline{UW(UNC)}$ CO-SPECTRA

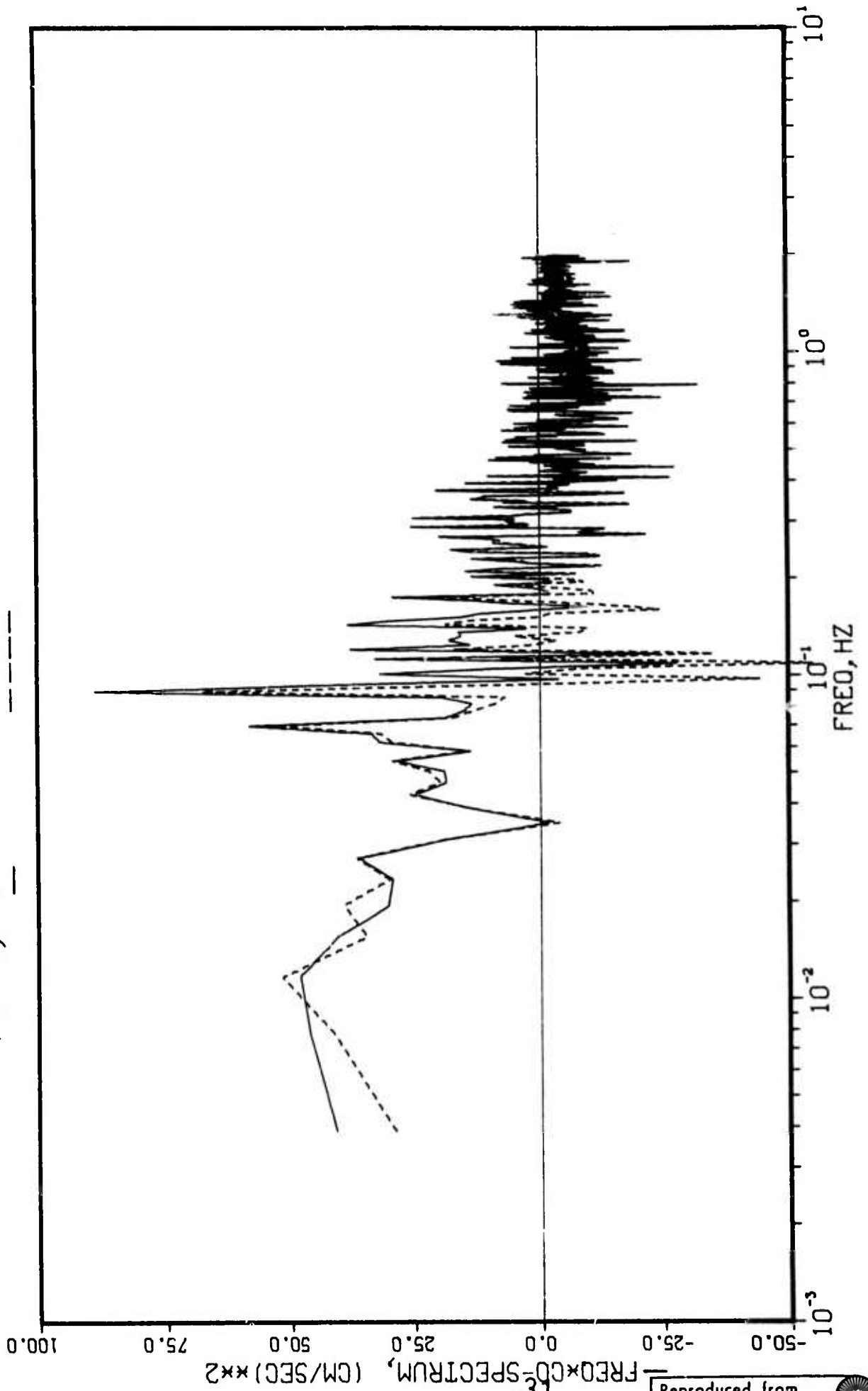
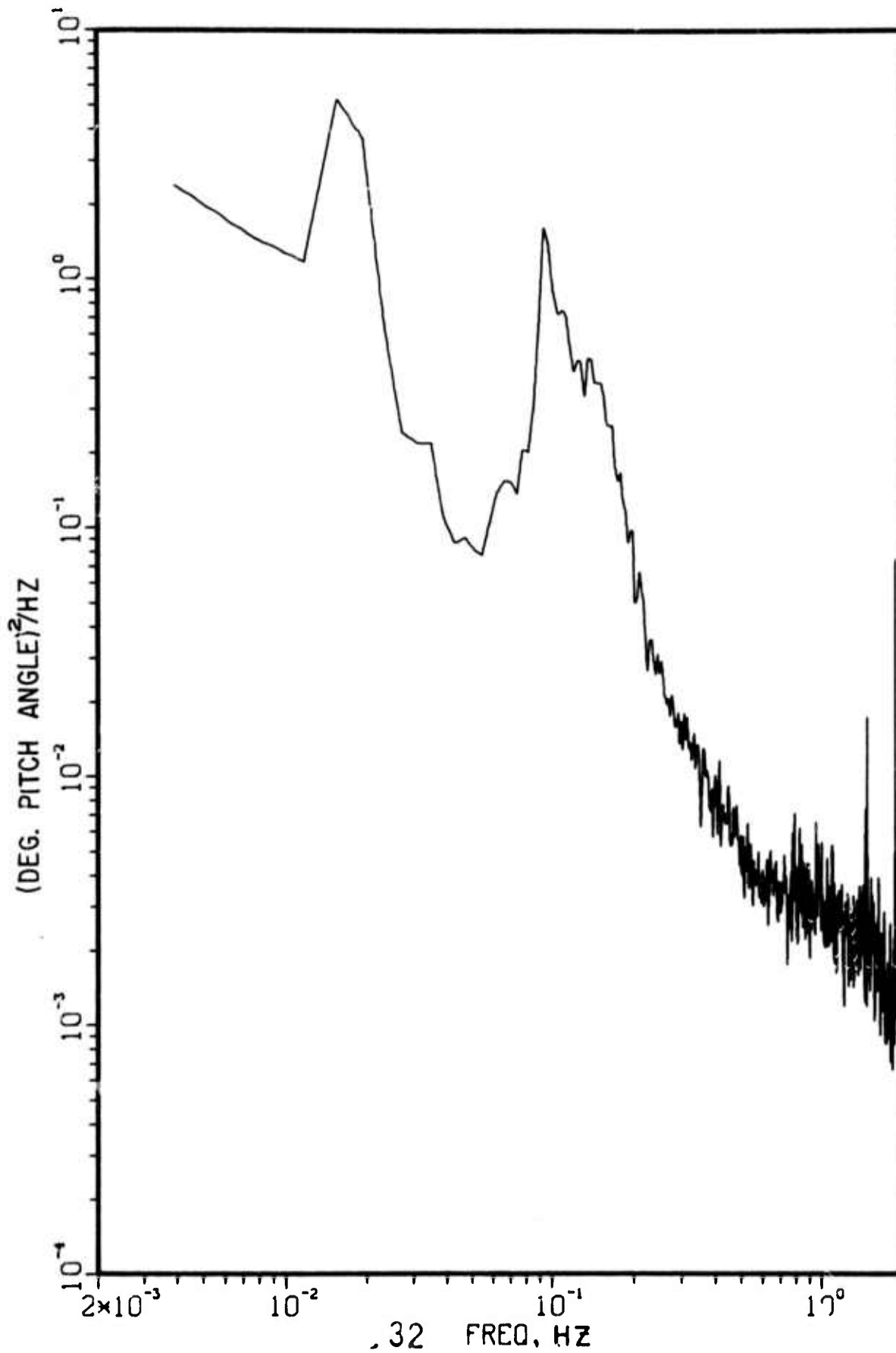

FIGURE 4
M3D4 GYRO FILE 6 , DEG.



FLIP Operation OWAX (Ocean Wave-Atmospheric Experiment)
OUTLINE - March 5-16, 1973

Objectives:

The general objectives of this experiment are: 1) characterize surface waves and their interaction with the air flow, 2) characterize spatial scales of high frequency surface waves, 3) characterize small scale sea surface temperature fluctuations and their relation to air temperature and humidity fluctuations, water temperature and conductivity fluctuations, surface waves, heat transfer and wind stress, and 4) measure the motion of FLIP, determine the response of FLIP to waves, and correct various observed data for FLIP's motion.

Methods:

1. Wave measurement: Small diameter, resistance wire sensors with six channels of a.c. bridge amplifiers with equivalent input noise level of 0.2 mm will be used. Output bandwidth is 500 Hz, with a parallel output of the time derivative for optimum signal-processing and recording. Placement of wave sensors per sketch:

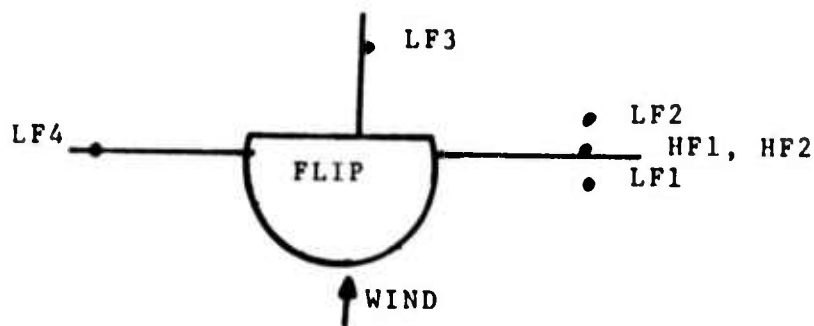

The multi-sensor array on the port boom will be attached to a beam mechanically buffered from unwanted port boom vibrations.

2. Turbulent air flow measurement: An EG&G three-component sonic anemometer will be used for air velocity measurement for frequencies to 10 Hz. The anemometer will be mounted on a vertical pole on the port boom, and positioned as close to the wave crests as possible for the wind-wave data. Other instruments will also be mounted on the pole assembly: a cup anemometer, fast response wind direction vane, a vertical gyroscope system (developed by R. E. Davis), and X-film anemometer probes for high frequency measurements of horizontal and vertical velocity components.

3. Air temperature and humidity measurements: Air temperature fluctuations will be measured using 0.000025 inch diameter platinum wire sensors and d.c. to 8 KHz low-noise a.c. bridges. Low frequency response thermistors will also be used because of their high sensitivity and strength. The spectra and statistics of the temperature signals obtained from the two methods above will be compared to those obtained with the temperature signal from a high frequency response circuit used by Professor Noel E. Boston (U. S. Naval Post-graduate School) to identify any instrument response problems. Humidity fluctuations will be measured by Lyman- α humidimeters, with response d.c. to approximately 5 Hz. The temperature and humidity sensors will be mounted on the vertical pole assembly.

4. Sea surface temperature: A Barnes PRT-5 precision radiation thermometer will be mounted on the port boom. The radiation thermometer has a field of view of 2° and 0.02° C sensitivity in d.c. to 3 Hz bandwidth. Mean sea surface and air temperature will be measured by a Hewlett-Packard quartz thermometer system. Air and water temperature fluctuations near the interface will be measured from a small float with a bandwidth of 20 Hz or better. Conductivity will tentatively be measured from the same float.

5. FLIP's motion: We will attempt to measure all 6 components of FLIP's motion (3 translational, 3 rotational) with the recently acquired Litton LTN-51 Inertial Navigation System. Also, non-gyro stabilized accelerometers and vertical gyroscopes (developed by R. E. Davis) will be used to measure selected motion components.

Equipment

In addition to the instrumentation mentioned above, adequate general purpose test gear and signal conditioning equipment will be

available. Recording equipment will be 1) - 14 channel FM Honeywell tape recorder, 2) Nova digital recording system, 3) 4-channel Hewlett-Packard FM tape recorder, and 4) T.I. computer/digital recorder. It is planned to obtain checks of the data on-board using a Federal Scientific Spectrum Analyzer system and the T.I. computer.

Analysis

1. Waves

a. The FLIP motion study will use the three low frequency probes LF 2, 3, 4 to estimate wave slope at FLIP's axis. Vertical and horizontal translation as well as pitch and roll angle will be measured using the Litton Industries motion sensor and/or a vertical gyro and accelerometers. These signals will be recorded by the NOVA computer and stored on magnetic tape. Onshore analysis will produce wave slope and FLIP motion spectra as well as the response function relating the two (output-2 months).

b. Estimates of frequency and directional distribution of wave energy below 1 Hz will be made from probes LF 1, 2, 3, 4 which will be recorded by the NOVA. Probes LF 1, 2 will be fed to the air study to be recorded with anemometer signals for air velocity/wave correlation.

c. A high frequency probe (HF) will be mechanically buffered from boom motion which will be measured with an accelerometer. Signals LF 1, 2 and HF will be recorded on analog tape for onshore analysis. Some analog spectral analysis will be attempted in real time. High frequency spectra will be correlated with wind speed (3 months).

d. An attempt will be made to deploy two high frequency probes at the position HF. We hope to develop a way of maintaining a stable physical separation of approximately 10 cm. Comparison of direct measurement of slope with that inferred from a single probe and local wave induced water motion will be attempted. This is a very uncertain project and must be considered basically developmental. If all goes well the data will be correlated with wind speed and phase of the large waves (schedule uncertain).

2. Wind Field: Velocity, Temperature and Humidity

a. In conjunction with the air velocity/wave correlation study described above, the basic sonic anemometer, X-film anemometer and Litton LTN-51 Inertial Navigation System data will be reduced to provide velocity data corrected for each component of FLIP's motion. This depends, of course, on obtaining good motion data from the Litton unit; some corrections to the velocity data can be made from the vertical gyro system data should the Litton

unit malfunction. One of the prime results to be calculated from the velocity data is the turbulent shear stress and its co-spectral shape. The spectra of the individual velocity components will also be calculated. With the X-film anemometer data, spectra at high frequencies will be calculated to determine if the velocity field is locally isotropic. It will also be possible to compare absolute outputs of the sonic anemometer, cup anemometer and hot-film anemometer; specifically the problem of cup-anemometer overspeeding will be studied.

Estimated analysis time: 4 months

b. In conjunction with the sea surface temperature measurements, the temperature and humidity data will be analyzed to provide the following: Spectral shapes of the temperature signals from the a.c. bridge, thermistor and Boston circuit will be compared to determine differing instrument response, if any. (It is planned to do this, at least qualitatively, during the experiment on FLIP using a spectrum analyzer and/or mini-computers). Recently, the absolute values and shapes of temperature spectra obtained over water have been found to differ significantly from what was predicted by early theories and spectra of another scalar in the atmosphere, humidity. At the present time, these differences and departures from theory are not understood. The temperature spectrum shape will be precisely determined and compared to the theoretical shape, and to the humidity spectrum. The correlation coefficient of temperature and humidity and the cospectrum will be calculated.

Estimated time: 4 months

3. Sea-Surface Temperature

The surface temperature measurements will be digitized and spectra computed. The relation of surface temperature with wave height and near surface air and water temperature will be investigated by computing spectra of these variables as well as cospectra with the surface temperature. We will investigate the effect of capillary waves on surface temperature (as predicted theoretically by Witting, 1972) by computing cospectra of surface temperature and a suitably time averaged energy of the capillary waves.*

* The spectra and cospectra will be related to simultaneous estimates of wind stress, solar radiation, back radiation, evaporation and heat transfer. 36

The difference between maximum and mean temperatures for each run will be computed and compared to a relation

$$\Delta T = \frac{\lambda Q \nu}{k(\tau/\rho_w)^{1/2}}$$

predicted by Saunders (1967) where λ is an arbitrary constant, Q is the total heat flux through the water just below the interface, ν is the kinematic viscosity, k the thermal conductivity of water, τ the air stress and ρ_w the water density. We hypothesize that the temperature fluctuations are largely due to the destruction of a cool film (~ 1 mm thickness) of water adjacent to the interface where the heat transfer is dominated by molecular processes. The difference between temperature maxima and mean would then closely approximate ΔT which is the difference between the mean surface temperature and the well-mixed water below. The constant λ will be determined.

Estimated analysis time - 4 months

Personnel:

Below is a tentative list of those participating in the experiment. The principal investigators are 1) Waves - Russ E. Davis, SIO, 2) Sea-Surface Temperature - C. Paulson, Oregon State University, and 3) Atmospheric Wind, Temperature and Humidity - C. Gibson/C. Friehe/F. Champagne.

<u>NAME</u>	<u>INSTITUTION</u>	<u>SPECIALTY</u>
1. F. Champagne	UCSD-AMES	Anemometry
2. T. Deaton	UCSD-AMES	Electronics
3. R. Davis	UCSD-SIO	Waves
4. G. Dial	UCSD-AMES	TI Computer
5. C. Friehe	UCSD-AMES	Litton System, Scientist-in-charge
6. C. Gibson or S. McConnell	UCSD-AMES	Temperature, Humidity
7. C. Paulson	OSU	Sea-Surface Temperature
8. L. Regier	UCSD-SIO	Waves, NOVA Computer
9. J. Simpson	OSU	Sea-Surface Temperature
10. Technician	OSU	Electronic maintenance and construction

Atmospheric Boundary Layer

Part I

Principal Investigator - Dr. Charles W. Van Atta
Phone (714) 453-2000, Extension 1624

Advanced Ocean Engineering Laboratory

sponsored by

Advanced Research Projects Agency

ONR Contract N00014-69-A-0200-6039

Atmospheric Boundary Layer

Part I

Table of Contents

1. Summary
2. Purpose
3. Instrumentation
4. Conclusion
5. Symbols
6. References

List of Figures

- Figure 1. Probe Heating and Nanowatt AC Bridge Power
Figure 2. Nanowatt AC Bridge Schematic
Figure 3. Resistance vs Temperature
Figure 4. Calibration curve for A Teledyne Geotech 6-cup Anemometer

Summary

The purpose of this investigation is to measure wind speed, air temperature, and wind direction over the ocean. The primary equipment for the measurements include DISA 55M series anemometers for measurement of high-frequency turbulent velocity and temperature fluctuations. Low frequency velocity data is obtained with a Teledyne Geotech cup anemometer and wind vane and an EG&C sonic anemometer. Calibration equipment has been purchased and assembled for field calibrations of velocity and temperature. The calibration equipment includes a Brinkman/Lauda refrigerated circulator for temperature calibrations, a TSI calibrating jet for velocity calibration of the hot-wire anemometer, and a nanowatt resistance bridge for resistance measurements of temperature and velocity probes. A traversing boom has been designed and built as an instrument platform for the sensors on the Naval Undersea Center Oceanographic Research Tower in San Diego. A systems check of all equipment has been performed in the laboratory. Since the funds for this experiment have been cancelled, data analysis will be completed in conjunction with the preparation of a final report.

1. Purpose

Wind speed, direction, and air temperature are the quantities which are measured over the ocean. The measurements initially were made from the Naval Undersea Center Oceanographic Research Tower in San Diego. A systems check of the field configuration has been completed in the laboratory.

2. Instrumentation

a. Small Scale Velocity and Temperature Measurements -
The small scales of atmospheric turbulence are measured with the DISA 55M series anemometer. Temperature and velocity can be simultaneously measured with a TSI model 1244 parallel sensor probe. The distance between the velocity and temperature sensor is .51 millimeters or approximately a half Kolmogorov length scale. The velocity sensor is a -10 TSI platinum film .025 millimeters in diameter by .51 millimeters long, and the temperature sensor is a .63 micron diameter by .63 millimeter long platinum wire. The frequency response of the film operated with a DISA 55M10 CTA Standard Bridge was measured in the laboratory as 9.4 kilohertz at 10 meters per second. From La Rue and Friehe the temperature sensor should have a frequency response of 6 kilohertz at 10 meters per second. The nominal resistances of the film and wire are, respectively, 8 ohms and 200 ohms.

A DISA 55M20 Temperature Bridge has been modified to accommodate 200 ohm wires for the measurement of temperature. The frequency response of the bridge has been measured with a square wave

which is internal to the bridge as 63 kilohertz. A calibration curve of the bridge has been generated by simulation of a 200-ohm probe with a General Radio Type 1433-W Decade Resistor whose accuracy is $\pm (.02\% + 2m \Omega)$. The gain is .360 ohms per volt or for a platinum wire .52 degrees Centigrade per volt. The output voltage is linear from .5 to 14.5 volts. The rms noise level was measured with a Hewlett-Packard 3400A rms voltmeter as .0025°C with a dummy resistor and .006°C with a platinum wire. In comparison Yeh and Sepri had an rms noise of about .010°C with the Tektronix Q and 3C66 ac bridges and a .25 micron platinum wire.

b. Calibration Equipment

A system has been developed for the calibration of velocity and temperature wires in a field experiment. The components of this systems are a TSI Model 1125 Calibrator, Brinkman/Lauda K-4/RD refrigerated circulator, and a nanowatt ac resistance bridge.

The TSI probe can be calibrated for both temperature and velocity with the TSI calibrator and Brinkman refrigerated circulator. The air for calibration is circulated from the TSI calibrator through a radiator which is suspended in the Brinkman circulator. The air finally returns to the TSI calibrator and then exits through the calibrating jet. Thus, the calibrator controls the air velocity, and the circulator controls the air temperature.

Since the DISA temperature bridge detects changes in resistance, the temperature coefficient of electrical resistivity must be known for determination of bridge output as a function of temperature whenever bridge gain is determined with fixed resistors. The nominal value for platinum wire is .0035/°C (Hinze) to .0038/°C (Bradshaw), but the exact value for a particular spool of wire must be determined experimentally. From Hinze the linear relationship between temperature and resistance is

$$\frac{R}{R_0} = 1 + \alpha(T - T_0) \quad (1)$$

Thus, α can be measured from the slope of a plot of R versus T. The measurement of the above quantities requires a stable temperature bath and an accurate resistance bridge.

The Brinkman bath is a stable temperature environment of $\pm .02^\circ\text{C}$. Since the small resistance wire is very delicate, the probe cannot be submerged directly in the circulator. The probe is mounted in a copper test tube which is submerged in the bath.

A special resistance bridge was designed by Tom Deaton and built by Rich Reineman for the resistance measurement. The bridge was built to meet two criteria: high accuracy and low power.

The accuracy was estimated from Eq (1) as follows. Equation (1) was solved for α and then differentiated.

$$\frac{d\alpha}{\alpha} = - \frac{dT}{T-T_0} + \frac{R}{R-R_0} \frac{\alpha R}{R} \quad (2)$$

For $T_0 = 20^\circ\text{C}$, $T - T_0 = 10^\circ\text{C}$, and $R_0 = 200\Omega$ the above equation becomes for a platinum wire

$$d\alpha/\alpha = 0.1dT + 30dR/R \quad (3)$$

Thus, a thermometer accurate to 0.1°C will affect the accuracy of α by one percent, while a .033 percent (.067%) accurate resistance measurement will affect α by one percent. This calculation demonstrates the necessity for an accurate resistance bridge for the measurement of α .

The second factor in the design of the bridge is the current through the probe. The current must be small enough that the current does not alter the probe resistance. As a design parameter a current which would heat the wire between $.010^\circ\text{C}$ and $.001^\circ\text{C}$ above ambient would be allowable. From Eq(1) a $.01^\circ\text{C}$ temperature is effectively an error in resistance of .0035 percent which is an order of magnitude smaller than the .03 percent bridge accuracy previously stated.

From Collis and Williams the heat transfer with no flow is given by

$$Q = \pi k \Delta T N = I^2 R \quad (4a)$$

$$N^{-1} = 0.88 - 0.43 \log_{10} G \quad (4b)$$

Equation (4b) is an empirical formula which is valid for $10^{-10} < G < 10^{-2}$. The other design parameters selected were an l/d of 1000 and an ambient temperature of 20°C . The results are plotted in Figure 1. For a 200 ohm wire heated $.15^\circ\text{C}$ above ambient temperature the power is 88 nanowatts, the Grashof number is 5.6×10^{-12} , and the current 21 μa . At $.015^\circ\text{C}$ the power is 8.2 nanowatts, the Grashof number 5.5×10^{-13} , and the current 3.6 μa .

The ac resistance bridge in Fig 2 was designed by Tom Deaton for this application. The reference resistance is the GR decade resistor previously mentioned. The accuracy of the bridge is limited by the accuracy of the GR decade resistor. The other two legs of the Wheatstone bridge contain ESI $10 \text{ k}\Omega \pm .01\%$ wire-wound precision resistors. The bridge resolution is .01 ohms, and its accuracy has been verified with several ESI .01 percent resistors. The power output of the bridge is plotted in Fig 1. A temperature-resistance curve for the platinum wire which is presently being mounted on the TSI probes is contained in Fig 3. From the slope of this curve, α is $.00350/^\circ\text{C}$.

c. Large Scale Velocity Measurements

The low frequency components of the atmospheric turbulence are measured with a Teledyne Geotech cup anemometer and wind vane and an EG&G sonic anemometer. The Teledyne equipment has been received and tested in the AMES wind tunnel. The sonic anemometer has been received, but electronics for the analog output signals are under construction in the AMES electronics shop as part of the ARPA contract effort by Prof. C. H. Gibson.

Figure 4 is a calibration curve of a Teledyne Geotech model 170-43 staggered, six-cup anemometer. This figure also contains a plot of the peak-to-peak noise as a function of velocity. The output voltage of the cup anemometer has a low frequency oscillation of about one or two hertz. Apparently the low frequency oscillation is associated with the cup dynamics. The important feature of the noise characteristic is that the noise for a 3-cup anemometer is considerably more. Between 6 and 15 meters per second the peak-to-peak noise for the six cup is about half that of the 3-cup anemometer.

d. Traversing Boom

A traversing boom has been designed and built for the experiment on the NUC Tower. The boom is a three-meter horizontal cantilever which can travel vertically on a 20-meter Tri-Ex radio tower. The azimuth of the cantilever can be changed via a hand-cracked worm-gear mechanism. An instrument platform with levelling screws is fastened at the end of the boom. The sensors for the instrumentation previously described can be mounted on this instrument platform during data acquisition.

e. Instrumentation Recorder

The data for this experiment, which include velocity, temperature, and their derivatives, are recorded on a one inch Sangamo 3500 instrumentation recorder. A total of twelve channels FM record and reproduce are available. Signals are recorded at $7\frac{1}{2}$ ips with a frequency bandwidth from dc to 2.5 khz. At this tape speed 3.2 hours of continuous recording is possible with a 7200 foot of Ampex tape. The signal-to-noise ratio is about 41db. Various amplifiers, two oscilloscopes, and a 400 line Federal Scientific spectrum analyzer are used to amplify and to monitor the signals as they are recorded.

3. Conclusion

During the past nine months equipment has been procured, developed, and tested. To date the performance of the equipment has either met or exceeded expectations. Since this portion of the contract will not be renewed, the research effort being supported herein will be phase out. When data analysis is completed, a final report will be written.

SYMBOLS

English

d	Wire diameter, cm
g	Gravitational constant, 980 cm/sec ²
G	Grashof number, $\frac{gd^3 \Delta T}{\nu^2 T}$
I	RMS current, amperes
k	Thermal conductivity, 2.54 x 10 ⁻⁴ joules/cm-sec-°C for air
l	Wire length, cm
N	Nusselt number, $\frac{Q}{\pi l k \Delta T}$
Q	Heat transfer rate or power, watts
R	Wire resistance, ohms
T	Temperature, °C

Greek

α	Temperature coefficient of electrical resistivity, °C ⁻¹
ν	Kinematic viscosity, 0.15 cm ² /sec for air

REFERENCES

- Bradshaw, P. An Introduction to Turbulence and its Measurement, Pergamon Press, Oxford (1971).
- Collis, D. C. and M. J. Williams, "Two-dimensional convection from heated wires at low Reynolds numbers", Journal of Fluid Mechanics 6:357 (1959).
- Hinze, J. O. Turbulence, McGraw-Hill Book Company, Inc., New York (1959).
- La Rue, John and Carl Friehe, "Some Characteristics of Platinum Wire Temperature Probes", Bulletin of the American Physical Society 16:1324 (1971).
- Sepri, Paavo, Turbulence in Constant Density Fluids with Thermal Fluctuations, Ph.D Dissertation, University of California at San Diego, La Jolla (1971).
- Yeh, Tsyh-Tyan, Scalar Spectral Transfer and Higher-Order Correlations of Velocity and Temperature Fluctuations in Heated Grid Turbulence, Ph.D dissertation, University of California at San Diego, La Jolla (1971).

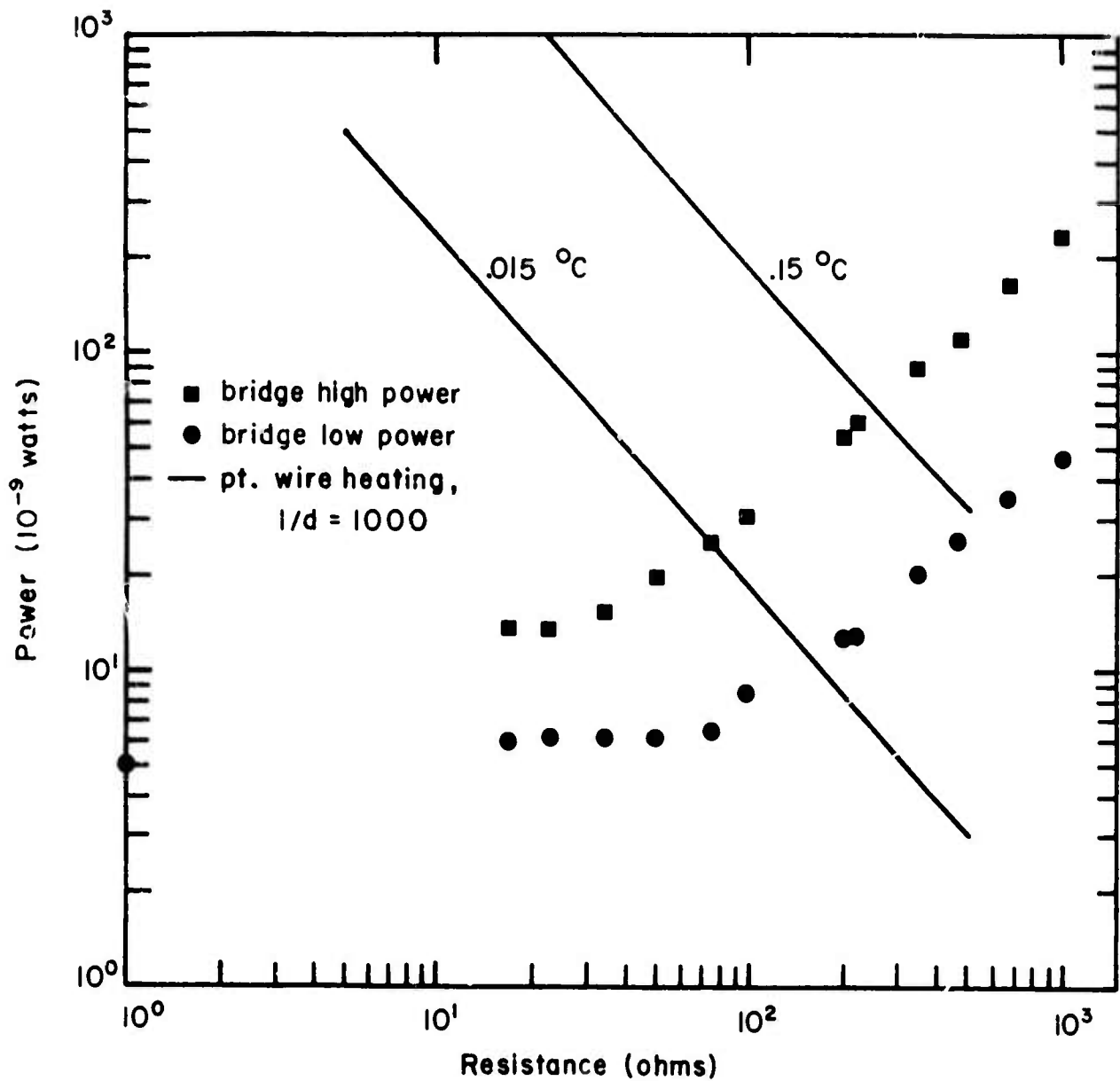

FIGURE 1: PROBE HEATING & NANOWATT
AC BRIDGE POWER

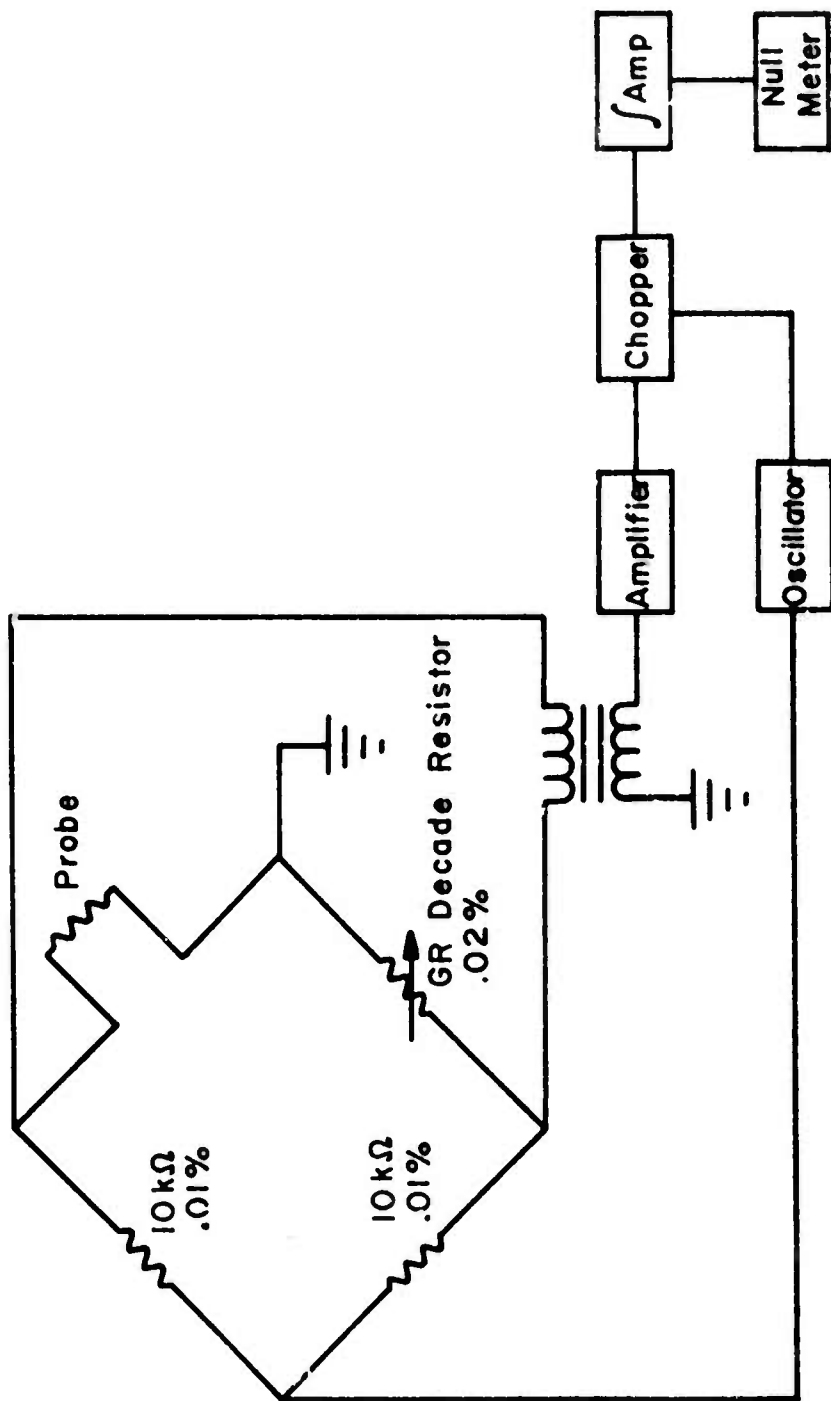

FIGURE 2: NANOWATT AC BRIDGE SCHEMATIC

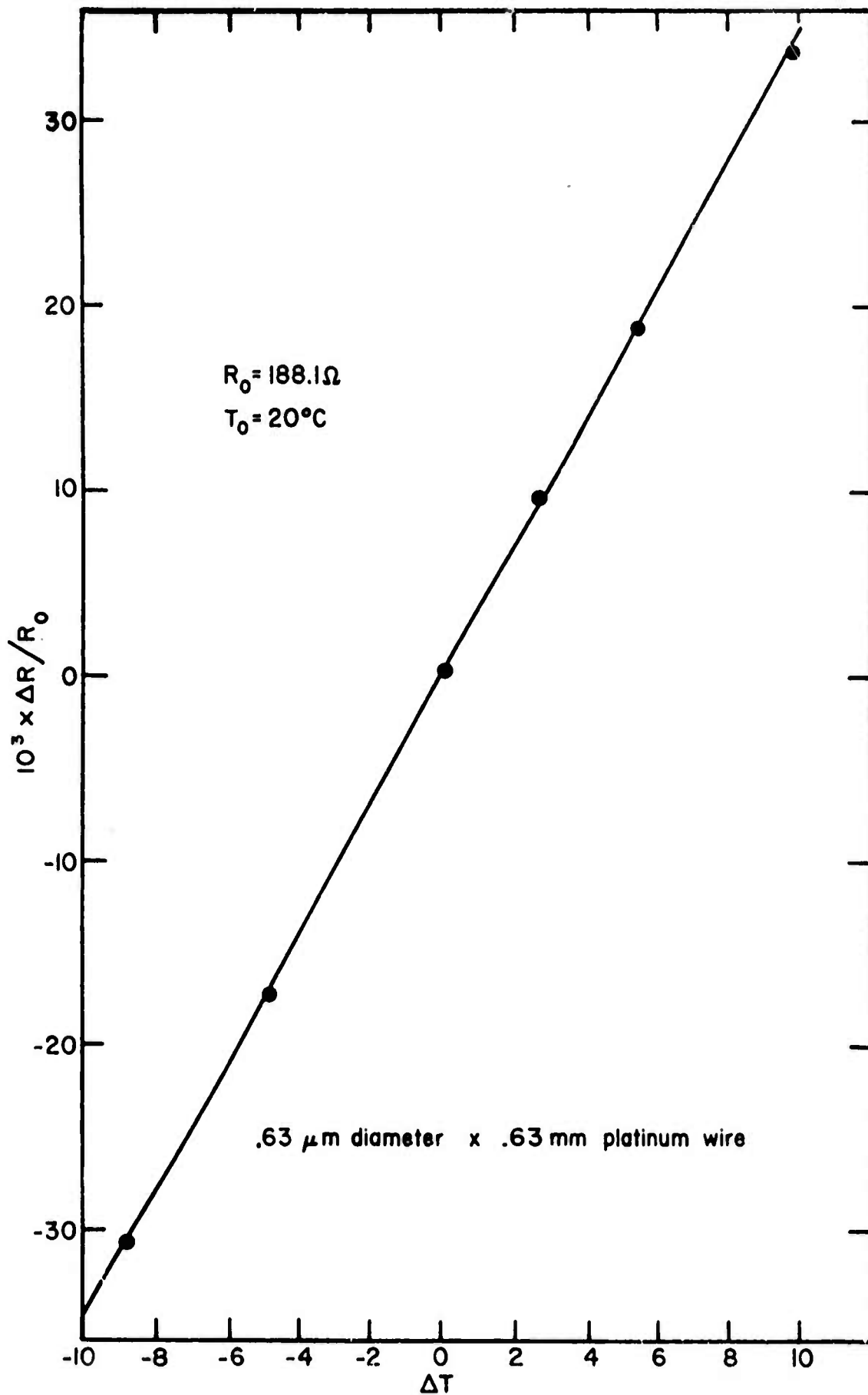

FIGURE 3: RESISTANCE VS TEMPERATURE.

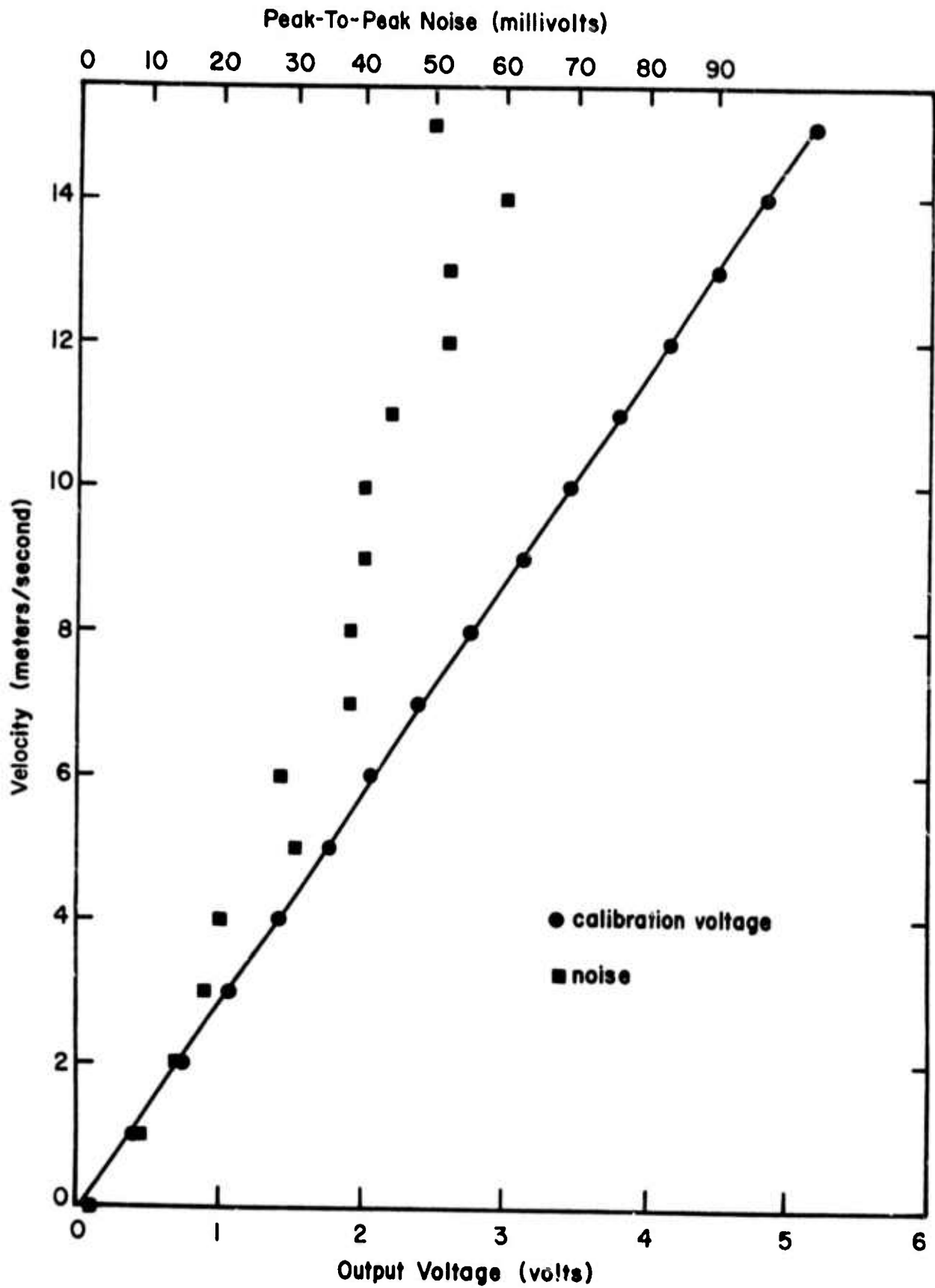

FIGURE 4: CALIBRATION CURVE FOR A
TELEDYNE GEOTECH 6-CUP ANEMOMETER.