

AD-761 124

RESEARCH STUDY IN EVALUATION OF GRAPHITE
RIBBON COMPOSITES

PFIZER INC.

PREPARED FOR
ARMY MATERIALS AND MECHANICS RESEARCH CENTER

DECEMBER 1972

Distributed By:

NTIS

National Technical Information Service
U. S. DEPARTMENT OF COMMERCE



AMMRC CTR 72-28

AD 761124

RESEARCH STUDY IN EVALUATION OF
GRAPHITE RIBBON COMPOSITES

December, 1972

ROBERT W. FROBERG
Pfizer, Inc.
Easton, Penna. 18042



Reproduced by
NATIONAL TECHNICAL
INFORMATION SERVICE
U S Department of Commerce
Springfield VA 22151

FINAL REPORT—CONTRACT NO. DAAG46-72-C-0071

Approved for public release; distribution unlimited.

Prepared for

ARMY MATERIALS AND MECHANICS RESEARCH CENTER
Watertown, Massachusetts 02172

RECORDS for	
DATE	State Section <input checked="" type="checkbox"/>
OFFICE	Self Section <input type="checkbox"/>
ACQUISITION	
BY	
DISTRIBUTION/AVAILABILITY CODES	
Dist.	Avail. and/or Special
A	

The findings in this report are not to be construed as an official Department of the Army position, unless so designated by other authorized documents.

Mention of any trade names or manufacturers in this report shall not be construed as advertising nor as an official indorsement or approval of such products or companies by the United States Government.

DISPOSITION INSTRUCTIONS

Destroy this report when it is no longer needed.
Do not return it to the originator.

AMMRC CTR-72-28

RESEARCH STUDY IN EVALUATION OF
GRAPHITE RIBBON COMPOSITES

Technical Report by

ROBERT W. FROBERG

Pfizer, Inc.

Easton, Penna. 18042

December 1972

FINAL REPORT—CONTRACT NO. DAAG46-72-C-0071

Approved for public release; distribution unlimited.

Prepared for

ARMY MATERIALS AND MECHANICS RESEARCH CENTER

Watertown, Massachusetts 02172

FOREWORD

The program reported herein was authorized by The Army Materials and Mechanics Research Center, Watertown, Massachusetts 02172, under AMMRC Contract DAAG46-72-C-0071, D/A Project 1W962113A661, AMCMS Code 502N. 11.0.7000, Reduction of Vulnerability of ABM System.

The author acknowledges the contribution of the following people to the program: Mr. Harry S. Katz, Utility Research Company, Montclair, New Jersey, for developing the composite fabrication techniques and for valuable technical liaison during the program; Mr. Harold E. Brandmaier for data reduction and analysis; and to Messrs. Philip DeMilio and William Hendershot for assistance in the fabrication and testing of the graphite film.

Unclassified

Security Classification

DOCUMENT CONTROL DATA - R & D

(Security classification of title, body of abstract and indexing annotation must be entered when the overall report is classified)

1. ORIGINATING ACTIVITY (Corporate author) Pfizer, Inc. Easton, Pa.		5a. REPORT SECURITY CLASSIFICATION Unclassified	
		5b. GROUP	
3. REPORT TITLE Research Study in Evaluation of Graphite Ribbon Composites			
4. DESCRIPTIVE NOTES (Type of report and inclusive dates) Final Report 1 Dec 1973			
5. AUTHOR(S) (First name, middle initial, last name) Robert W. Froberg			
6. REPORT DATE Dec 1972		7c. TOTAL NO. OF PAGES 101 99	7d. NO. OF REFS 19
8a. CONTRACT OR GRANT NO. DAAG 46-72-c-0071		8b. ORIGINATOR'S REPORT NUMBER(S) Min RC CTR 72-28	
b. PROJECT NO.		8c. OTHER REPORT NO(S) (Any other numbers that may be assigned to the report)	
c.			
d.			
10. DISTRIBUTION STATEMENT Approved for public release distribution unlimited			
11. SUPPLEMENTARY NOTES		12. SPONSORING MILITARY ACTIVITY Army materials and mechanics research center Watertown, Massachusetts 02172	

13. ABSTRACT

This graphite film, rather than graphite filaments, may be the preferred reinforcement for some advanced composite applications because the 0.0003-inch thick film is more readily adapted to the fabrication of thin planar isotropic laminates in the range of 0.0003-inch to 0.020-inch thick.

This report covers the research program on the preparation and testing of pyrolytic graphite film polymeric matrix laminates. The films that were used ranged between 0.0001-inch 0.0004-inch in thickness with the nominal value about 0.0003-inch. The tensile strength of the material ranged between 30 ksi and 110 ksi and the tensile modulus between 3 million psi respectively. The average density was about 1.6 gm/cc.

The first step in the program was to qualitatively determine the bondability of the graphite film. This was accomplished by the preparation and testing of lap shear bond test samples. An epoxy-polyamide adhesive and a resin based on Union Carbide Epoxy Resin ERLA 4617 both yielded lap shear bond strengths in order of 1000 psi.

Methods for handling the thin high modulus film were developed, and multi-ply laminates were molded. Five different bonding agents or matrices were used. The laminates were about 0.003-inches thick and contained from 4 to 6 plies of graphite film. Different structural configurations were prepared, such as full ply test laminates, longitudinal thin strip laminates, and longitudinal tile structures. The tensile strength of the laminates ranged between 30 ksi and 59 ksi, and elastic moduli between 4 million psi and 5.9 million psi. The higher values compare favorably with those of a quasi-isotropic graphite filament composite, which would be the structure needed for end uses that require a planar isotropic material. Composite efficiencies based upon the rule of mixtures, ranged well above 50%. This indicates that effective and useable composite can be fabricated from the graphite film.

DD FORM 1473

REPLACES DD FORM 1473, 1 JAN 64, WHICH IS OBSOLETE FOR ARMY USE.

UNCLASSIFIED Security Classification

114

14 KEY WORDS	LINK A		LINK B		LINK C	
	ROLE	WT	ROLE	WT	ROLE	WT
Graphite Films Composite Materials Mechanical Properties Laminates Composite Fabrication						

11b

ABSTRACT

Thin graphite film, rather than graphite filaments, may be the preferred reinforcement for some advanced composite applications because the 0.0003-inch thick film is more readily adapted to the fabrication of thin planar isotropic laminates in the range of 0.0003-inch to 0.020-inch thick.

This report covers the research program on the preparation and testing of pyrolytic graphite film polymeric matrix laminates. The films that were used ranged between 0.0001-inch 0.0004-inch in thickness with the nominal value about 0.0003-inch. The tensile strength of the material ranged between 30 ksi and 110 ksi and the tensile modulus between 3 million psi and 13 million psi, with the average about 60 ksi and 7 million psi respectively. The average density was about 1.6 gm/cc.

The first step in the program was to qualitatively determine the bondability of the graphite film. This was accomplished by the preparation and testing of lap shear bond test samples. An epoxy-polyamide adhesive and a resin based on Union Carbide Epoxy Resin ERLA 4617 both yielded lap shear bond strengths in the order of 1000 psi.

Methods for handling the thin high modulus film were developed, and multi-ply laminates were molded. Five different bonding agents or matrices were used. The laminates were about 0.003-inches thick and contained from 4 to 6 plies of graphite film. Different structural configurations were prepared, such as full ply test laminates, longitudinal thin strip laminates, and longitudinal tile structures. The tensile strength of the laminates ranged between 30 ksi and 59 ksi, and elastic moduli between 4 million psi and 5.9 million psi. The higher values compare favorably with those of a quasi-isotropic graphite filament composite, which would be the structure needed for end uses that require a planar isotropic material. Composite efficiencies based upon the rule of mixtures, ranged well above 50%. This indicates that effective and useable composites can be fabricated from the graphite film.

TABLE OF CONTENTS

TITLE PAGE	i
FOREWORD	ii
ABSTRACT	iii
LIST OF TABLES	v
LIST OF FIGURES	vi & vii
SUMMARY	1
I. INTRODUCTION	3
II. TECHNICAL DISCUSSION	4
2.1 Micromechanics	4
2.2 Macromechanics	6
2.3 Applications	8
III. EXPERIMENTAL PROGRAM	10
3.1 Film Preparation	10
3.2 Composite Preparation	10
3.3 Test Program	10
3.4 Data Analysis	10
IV. EXPERIMENTAL RESULTS	12
4.1 Film Preparation	12
4.2 Composite Fabrication	12
4.3 Mechanical Testing	24
V. DISCUSSION OF RESULTS	35
5.1 Criteria for Composite Evaluation	35
5.2 Graphite Film Tensile Properties	36
5.3 Composite Tensile Properties	36
5.4 Composite Flexure Properties	44
5.5 Assessment of Test Results	44
VI. CONCLUSIONS AND RECOMMENDATIONS	47
6.1 Conclusions	47
6.2 Recommendations	47
VII. REFERENCES	48
VIII. APPENDICES	48
A Pyrolytic Film Tensile Data	48
B Film Data Summary	60
C Composite Tensile Data	63
D Composite Tensile Summary	71
E Composite Efficiency Data	76
F Two Material Beam Analysis	81
G Flexure Data	85
H Flexure Data Summary	87

LIST OF TABLES

Table	Page
1 Matrix Materials	15
2 Film Properties as a Function of Film Thickness	36
3 Multi-Ply Efficiency Data	38
4 Effect of Matrix on Composite	40
5 Effect of Film Isotropy on Composite Properties	40
6 Effect of Number of Plies on Composite Properties	40
7 Effect of Structure on Composite Properties	44
8 Tensile/Flexural Data Comparison	45
9 Reproducibility of Film Data	45
10 Reproducibility of Composite Data	45
11 Effect of Thickness on Properties	46

LIST OF FIGURES

1	Composite Types	5
2	Variation of Transverse Modulus with Reinforcement Volume and Aspect Ratio	7
3	Variation of Tensile Modulus with Orientation	7
4	Variation of Tensile Strength with Orientation	9
5	Comparison of Composites with Isotropic Materials	9
6	Film Deposition Apparatus	11
7	Deposition Reactor	11
8	Film Specimen Mount	11
9	Instron Test Machine	11
10	Knife Coating Setup	14
11	Flat Plate Molding	16
12	Laminate Preform Buildup	16
13	Teflon Film Removal	19
14	Teflon Film Removal	19
15	Multi Cavity Mold	20
16	Laminate Preform	20
17	Laminate Cross Section	20
18	Enclosed Panel Mold	21
19	Test Laminate Structures	22
20	Tabbed Tensile Specimen	23
21	Tab Bonding Fixture	23
22	Tensile Specimen Before Test	25
23	Tensile Specimen After Test	25
24	Correction of Load-Elongation Curve	25
25	Testing Machine Calibration	25
26	Load-Elongation No. T-14-A	27
27	Load-Elongation No. 318-4	27
28	Load-Elongation No. 316-4	27

29	Load-Elongation No. 105-5	27
30	Load-Elongation No. 291-4	28
31	Tensile Specimen After Test	28
32	Excellent Laminate No. 304-4	28
33	Good Laminates No. 251-T4C, No. T-13-B	30
34	Fair Laminates No. T-8-A, No. T-14-B	30
35	Poor Laminates No. T-6-B, No. T-11-C	31
36	Effect of Quality on Composite Performance	31
37	Load Elongation Tensile Curves	31
38	Correction for Crosshead Travel	33
39	Effect of Crosshead Speed on Film Properties	33
40	Flexure Test Setup	33
41	Flexure Test Fixture	34
42	Flexure Failure Modes	34
43	Test Laminate Structures	34
44	Distribution of Modulus and Strength	37
45	Effect of Gage Length on Film Properties	37
46	Effect of Film Thickness on Strength and Modulus	37
47	Effect of Specific Gravity on Film Properties	37
48	Effect of Reinforcement Volume on Strength Efficiency	39
49	Effect of Reinforcement Volume on Modulus Efficiency	39
50	Relationship Between Modulus and Strength Efficiency	41
51	Effect of Film Isotropy on Modulus Efficiency	41
52	Effect of Film Isotropy on Strength Efficiency	41
53	Effect of Film Isotropy on Composite Properties	41
54	Effect of Number of Plies on Modulus Efficiency	42
55	Effect of Number of Plies on Strength Efficiency	42
56	Test Laminate Structures	42
57	Effect of Structure on Composite Modulus Efficiency	42
58	Effect of Structure on Composite Strength Efficiency	43
59	Effect of Tile Spacing on Composite Efficiency	43

SUMMARY

A prime objective was accomplished by the demonstration that thin graphite film can be handled and effectively utilized in multi-ply composites employing a number of polymeric matrix materials.

Approximately eight sq. ft. of pyrolytic graphite film was manufactured for this program. The films that were used were between 0.0001-inch and 0.0004-inch in thickness, with the nominal value about 0.0003-inch. Most of the tensile strengths ranged between 30 ksi and 110 ksi and the elastic moduli between 3 million psi and 13 million psi, with the average about 60 ksi tensile strength and 7 million psi elastic modulus. The average density was about 1.6 gm/cc.

A good film-matrix bond is essential for an effective film laminate, and there was concern that the smooth graphite film surface might lead to

low bond strengths. Therefore, a cursory study of graphite film bondability was conducted by the use of lap shear bond tests. Various adhesives were used to bond a 1/4-inch x 1/4-inch square of graphite film between the ends of two 1/4-inch wide stainless steel and/or aluminum panels. An epoxy-polyimide adhesive, a resin based on Union Carbide ERLA 4617 Epoxy Resin, and a phenoxy film adhesive all yielded lap shear bond strengths in the order of 1000 psi.

A prime objective has been accomplished by the demonstration that graphite film properties can be effectively utilized in a multiple ply laminate or composite. For comparison with composite properties achieved with the graphite film the following table shows typical room temperature composite properties at a filament loading of about 52% with a representative graphite filament material.

PROPERTIES OF HERCULES GRAPHITE FILAMENT PREPREG TYPE 2002M

	Longitudinal	Crossplied	(±45°) Angle Plied	Estimated Quasi-Isotropic
Tensile Strength, Ksi	104	53	21.	40
Elastic Modulus, Msi	24	14	2.5	9

The graphite filaments cannot be used in some applications, such as those which require a thin, .003 to .005-inch, planar isotropic composite. This structure could not be produced from the relatively thick, .005-inch, unidirectional filamentary prepregs, especially since a minimum of five to eight plies would be required for a quasi-isotropic structure.

The thin, 0.0003-inch, graphite film can be fabricated into unusually thin composites. The average thickness of the test laminates of this program was in the order of 0.003-inch, and contained from four to six plies of graphite film. A number of the test results were low. However, this can be attributed to factors such as edge defects, non-optimized choice of matrix and fabrication method, and the inherent difficulties in tensile testing a thin high modulus material.

More importantly, a significant number of test samples resulted in relatively high composite physical properties and high composite efficiency. The measured composite tensile strengths ranged up to 60 ksi, and elastic moduli up to 5.9 Msi.

The higher values compare favorably with those of the quasi-isotropic graphite filamentary composite, which is the structure that would be required for end uses that need a thin planar isotropic material. Since this program represents the first exploratory effort in the fabrication of these film composites, it may be anticipated that when the main factors are optimized, such as initial film properties, proper choice of matrix and fabrication procedure, control of film volume and uniformity of matrix thickness, etc., that the film composite properties will exceed those of the quasi-isotropic graphite filament composite.

A fact that is even more significant is the relatively large number of high composite efficiency values. At early stages of composite fabrication with a new reinforcement, low composite efficiency may be anticipated, such as was the case with aluminum oxide whisker composites during the mid 1960's when investigators were not able to obtain polymer composite efficiencies much above 15%. In the current program, we may arbitrarily propose that a composite efficiency of

above 50% for strength and 65% for the elastic modulus would indicate that effective future composites could be made from this new graphite film. This level was exceeded by many samples, and a number of samples (primarily those with film of below average properties) had efficiencies above 100%. This would indicate that, within the composite structure, the matrix may minimize or eliminate the effects of local flaws and that the composite specimens were less likely to fail prematurely. The indications of good composite efficiency makes the further study of graphite film composites appear worthwhile.

Lap-shear bond strength tests indicated that a good level of bond strength, in the order of 1000 psi, could be obtained between the graphite film and an epoxy resin.

Procedures for handling the thin graphite film were developed as well as methods for constructing various film composite test configurations, such as full ply test laminates, longitudinal thin strip laminates, and longitudinal tile structures.

A possible improved method of flexural testing of a thin high modulus material was investigated. This consisted of a two-material flexural strength test, in which the graphite film laminate with a

thickness of about .003-inch was bonded to the tensile side of a 0.060-inch thick acrylic plastic panel. This method merits further study. The flexural tests showed that the addition of only 5% to the thickness of Plexiglas resulted in a panel with twice the modulus of Plexiglas. The graphite film composite may therefore be useful as a stiffener for low modulus structural materials.

The analysis of composite test data was based on composite efficiency with respect to modulus and strength. This basis was used because it provides a better indication of the potential value of a reinforcement material and is less sensitive to errors in measurement of film and composite thicknesses.

The results of this initial development program on graphite film composites are compared in the following table with properties of boron/polyimide composites (1, 2, 3) and with 2024T-62 aluminum alloy. It should be noted that this report represents the first limited exploratory program on graphite film composites. By comparison, the boron/polyimide film composites have been extensively developed for approximately five years and the aluminum alloy is, of course, a well established structural material.

Material	Reinforcement Vol. %	Ts Ksi	E Msi	ρ pci	Ts/ρ in. $\times 10^{-3}$	E/ρ in. $\times 10^{-3}$	Ref.
B/PI (Epoxy)		40	20	0.06	667	333	(1) this report
AL2024-T62		62	10.2	0.1	620	102	
G (Epoxy)	83.3	59.2	5.89	0.055	1060	108	Mil-HDBK-5B

As shown above, the specific tensile strength of the graphite film composites, as defined in this initial program, is comparable to materials which have been under development for longer periods. The specific modulus, however, is somewhat lower and, therefore, should be the subject of further development. In addition, in order to fully characterize the graphite film composite

materials, further work should include measurements of compressive and shear properties.

It should also be noted that since the graphite film is free of any substrate, there is no inherent upper limit to the volume loading attainable in composite fabrication as is the case with existing boron films.

I. INTRODUCTION

There is a continual demand for improved structural materials in military and industrial applications. The advanced composites have proven to be a breakthrough in highly improved and lightweight materials, and have already been adapted for many critical aerospace components. There have been a number of technical surveys that indicate a rapid future growth for advanced composites and an outstanding leader, because of physical properties and projected low cost, is the graphite filament-epoxy system. The future widespread utilization of this material appears certain, and an important adjunct material could be graphite film composites, which would be preferable for many applications.

In comparing the possible choice of film versus filament-reinforced-composites for a specific application, the following facts should be considered. The use of graphite filament as a reinforcement is ideal when the stress pattern on the component is unidirectional and the part can be a unidirectional composite. However, most structural parts are subjected to much more complex stress fields than the simple unidirectional mode, and the filament orientations in a high performance composite should be proportioned in accordance with the stress distribution. When filaments are oriented at an angle, there is a corresponding reduction of the unidirectional or 0° strength and modulus of the composite. Many structural components require a planar or transversely isotropic material, and in these cases the plies of unidirectional filaments must be oriented at various angles to give a quasi-isotropic structure that has approximately equal properties in any planar direction. In this case, the properties are substantially reduced from those of the unidirectional composite made from the same material, and the best graphite film laminates prepared in this program have comparable tensile strength and modulus to those of the quasi-isotropic graphic filament composites. Another fact that must be considered is that a number of potential applications require a thin composite, of the order of 0.005-inches. The current graphite filament unidirectional prepregs are about 0.005-inches per ply and the attainment of a quasi-isotropic structure would require the stacking of a minimum of 5 to 8 plies, so that it would not be practical to build certain structures with the

graphite filament material. However a very thin structure could be made with the graphite film material, which is only 0.0003-inch thick, and occupies less than 0.001-inch per ply in the molded laminate. Another advantageous feature of the film is its capability of being molded at high volume percent. In contrast, the optimum practical loading for graphite filaments in an epoxy matrix is about 60 volume percent. At higher levels, adjacent fibers touch and the physical properties decrease. Another advantageous feature of the film is its relatively low density of 1.6 gm/cc.

An important requirement of advanced composite parts is the capability of reliably joining and fastening such parts to other structural members. This often necessitates a bolted (riveted) connection or mechanical joint. Stress analyses have shown that the tensile stress rises locally to values from five to six times as high as the average value in regions adjacent to a bolt hole. A recent investigation showed that the addition of boron film material to a highly directional graphite fiber laminate increased the joint strength and stiffness up to 200 percent, the chief contribution of the boron film being high bearing strength and resistance to shear distortion (1, 2). The boron film was also effective in reducing the notch sensitivity of graphite fiber laminates, while at the same time substantially raising both the tensile strength and the work-to-fracture of the material (3). The graphite film could conceivably be used in a similar manner to improve the properties of graphite filament composites.

Applications where the graphite film may be the optimum reinforcement include the reinforcement bolt holes in filamentary composites, thin high performance laminates, skins for honeycomb structures, structures requiring high planar isotropic properties, aircraft wings, and tubular components with high specific strength and modulus.

A considerable amount of investigation has been devoted to the fabrication of graphite filament composites (4). However, there was no apparent prior art related to the handling of a thin high-modulus graphite film and its fabrication into good quality laminates. The main objectives of this program were to determine the feasibility of using Pfizer's graphite film as a reinforcement in a polymeric composite and to determine the extent to

which film properties are transferred to composite properties.

In order to meet the program objectives, the following were among the tasks considered necessary:

1. Learning to handle the thin high-modulus film so that edge defects, tears, and breakage could be minimized or avoided, and individual plies could be properly positioned.
2. Establishing that a relatively high level of bond strength could be achieved between the film

II. TECHNICAL DISCUSSION

Filamentary composites are characterized by a high elastic modulus and tensile strength in a direction parallel to the filaments (direction 1 in Figure 1) and relatively low values of these properties in directions perpendicular to the filaments (directions 2 and 3 in Figure 1). This results in large anisotropies in the plane containing the filaments, defined by directions 1 and 2. Conversely, the properties are isotropic in the transverse plane, defined by directions 2 and 3.

To effectively utilize filamentary composites, the designer must take into account the anisotropic nature of these materials. Thus, in specifying the filament orientation pattern in adjacent layers or plies of a laminated plate, he must consider the following effects not present with isotropic materials:

1. Applied normal stresses induce large shear strains similar to the effect of Poisson's ratio.
 - Similarly an applied flexural stress induces torsional strain.
2. Tensile stresses applied to an asymmetric laminate produce bending.
3. Elastic properties in tension differ from those in bending for an odd number of plies in a laminate.
4. Large Poisson's ratios for certain layup patterns.
5. Compressive strength differs significantly from tensile strength due to filament buckling in compression.
6. Negative coefficients of thermal expansion which may result in thermal cracking during the cure cycle.
7. Optimum filament orientation not in the prin-

and a polymeric matrix.

3. Evaluating a number of candidate matrices, to choose the most suitable.
4. Investigating methods for preform preparation, and molding of the test laminates.
5. Laminate testing.
6. Data analysis.

All of these tasks were accomplished, and the results indicated that the graphite film can be handled without due breakage and effective composites can be fabricated.

cipal stress direction when the transverse strength is less than the shear strength as it is for graphite/epoxy composites.

One approach to the solution of the composite anisotropy problem is the development of composites based on thin films rather than small diameter filaments. If the film is isotropic then the resulting composite material will be isotropic in the 1-2 plane in Figure 1; its properties will, however, be anisotropic in the lesser important 2-3 plane. These film composites may be referred to as being planar isotropic.

The characteristics of film, or planar isotropic, composites are described in the following sections. Some comparison is made with filamentary composites to illustrate the merits of planar isotropic composites.

2.1 Micromechanics

Micromechanics utilizes the properties of the matrix and reinforcement to predict the properties of a single ply of composite material.

The longitudinal modulus E_L , Poisson's ratio ν , and longitudinal strength S are satisfactorily predicted using the Rule-of-Mixtures (ROM). Thus,

$$E_L = X_R E_R + X_M E_M \quad 2-1$$

$$\nu = X_R \nu_R + X_M \nu_M \quad 2-2$$

$$S = X_R S_R + X_M S_M \quad 2-3$$

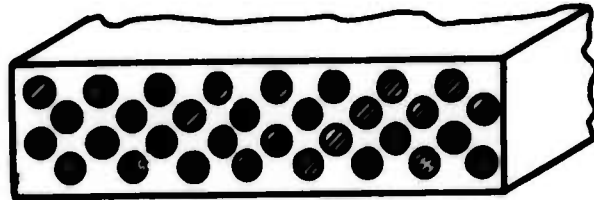
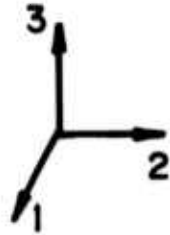

a) FILAMENTARY; $a/b \sim 1$

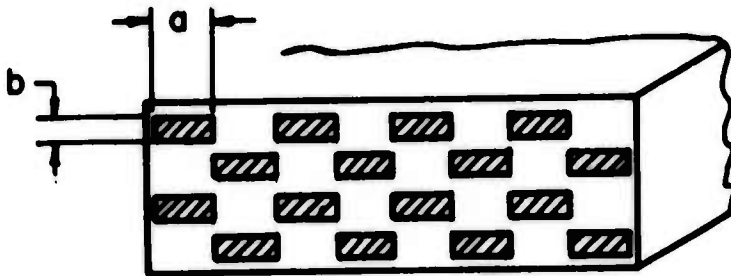

b) RIBBON; $1 < a/b < \infty$

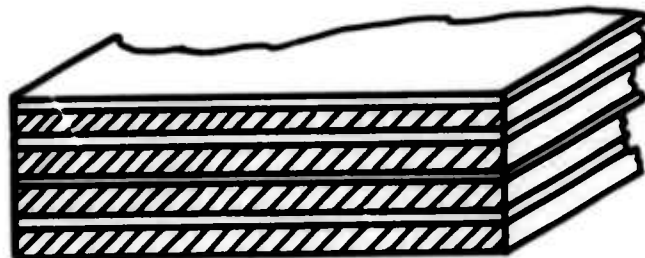

c) FILM; $a/b = \infty$

FIGURE 1. COMPOSITE TYPES

where X is the volume percent and the subscripts R and M refer to reinforcement and matrix respectively. Reliable predictions of the transverse modulus E_T and the shear modulus are considerably more difficult. However, using Hermann's "self-consistent" analytical composite model (5), Halpin (6) developed a simple generalized equation applicable to filamentary and other reinforcements. This yields the following for transverse modulus,

$$E_T = \frac{1 + \epsilon \alpha X_R}{1 - \alpha X_R} \quad 2-4$$

where

$$\alpha = \frac{\frac{E_R}{E_M} - 1}{\frac{E_R}{E_M} + \xi} \quad 2-5$$

and ϵ is a function of the reinforcement type.

For ribbon reinforcement where a and b are the ribbon width and thickness, respectively,

$$\xi = 2(a/b) \quad 2-6$$

Halpin (13) derived this equation by using equation (4-4) with the adjustable factor ϵ to curve fit analytical results obtained using the finite element method.

Figure 2 shows (E/E_M) as a function of reinforcement volume and aspect ratio a/b . The lower limit, corresponding to $a = b$ or a square (or round) filament, yields the familiar result that the transverse modulus is only appreciably greater than the matrix modulus at high reinforcement volumes. The upper limit, corresponding to $a = \infty$ or a film, yields equation (2-4). It is interesting to note that very little difference in modulus exists between a film and a 0.0002 inch thick ribbon whose width exceeds 0.02 inches. This result and crack propagation considerations led to the strip form of composite structure illustrated in Figure 3.

In the case of the strip models tested in this program, a/b was about 250.

Although the transverse modulus of a ribbon approaches that of a film for aspect ratios greater than 100, the strength does not, due to stress concentration at the extremities of the ribbon. The problem is similar to that of the longitudinal strength of short filament composites. In an analytical and photoelastic study of these stress concentrations, Chen and Lewis (7) found that the transverse ribbon stress could exceed the film stress by 50% for a given applied stress. This strength anisotropy of a strip laminate was not measured in the course of this program.

In the case of segmentation in the longitudinal direction, stress concentrations similar to that described by Chen and Lewis for the transverse direction can be assumed to occur, thereby reducing the longitudinal strength as well as the transverse strength. A composite structure based on segmentation in both longitudinal and transverse directions is referred to in this program, as "tile" form of construction. Tests results at least partially bear out the thesis of this brief discussion - that a discontinuous composite structure is weaker than a continuous structure. One aspect of composite behavior which may not support this conclusion is the effect of discontinuities, or resin - film interfaces, on the propagation of cracks originating at the edge of a composite structure (a tensile specimen, for example). Thus, if these interfaces arrest, attenuate, or redirect cracks propagation, the measured strength of a strip or tile composite may exceed the strength of a continuous film composite; some of the experimental evidence presented in Section 5 supports this viewpoint.

2.2 Macromechanics

Macromechanics utilizes the properties of a single ply of composite material to estimate the properties of a composite structure such as a laminated plate.

In the case of a filamentary or fiber composite, the extreme anisotropy of ply properties necessitates changing filament orientation from ply to ply in a laminated plate to achieve the desired combination of properties. Figures 3 and 4 show the variation of tensile modulus and strength with direction for Hercules 2002M graphite/epoxy composite; the 0° and 90° properties are experimental values appearing in Hercules data sheets. The vari-

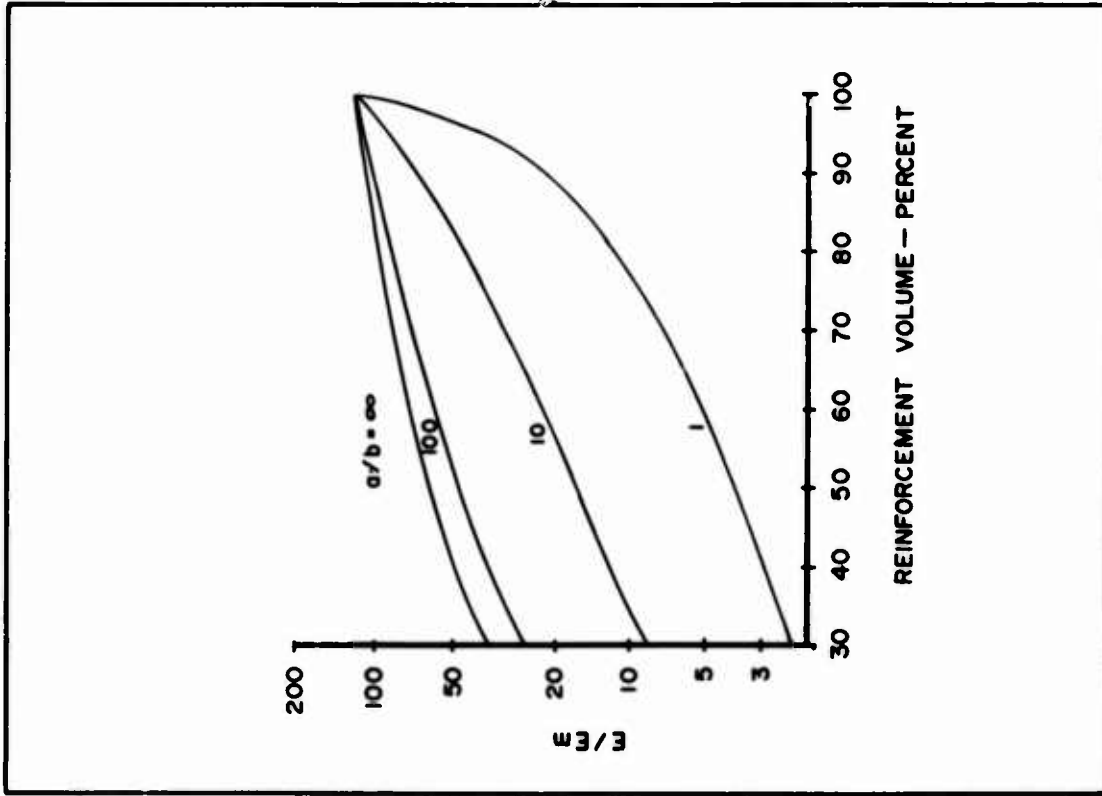

FIGURE 2. VARIATION OF TRANSVERSE MODULUS WITH REINFORCEMENT VOLUME AND ASPECT RATIO

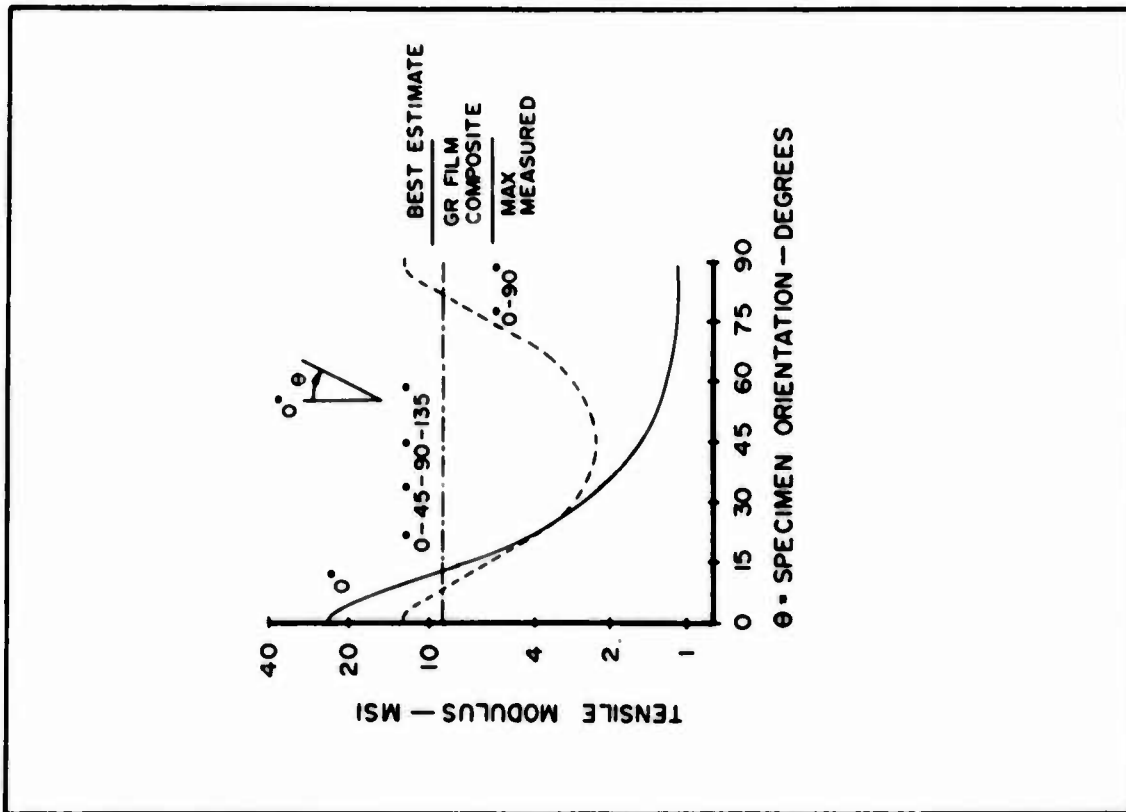

FIGURE 3. VARIATION OF TENSILE MODULUS WITH ORIENTATION

ation between 0° and 90° was calculated using the analytical methods of macromechanics; Tsai's energy approach (8) to estimating composite strength was assumed.

Uni-directional composites perform well when the load is uni-directional, i.e. along the 0° , or fiber, axis, as is the case for a column, or when there is an axial load and a flexural or bending load, but no torsion as in the components of some frames.

If adjacent plies of a laminate are made alternately 0° and 90° , the 90° modulus and strength are increased and the 0° values correspondingly reduced. As shown in Figures 3 and 4, the properties of this cross-ply laminate remain low over much of the intermediate range.

One limit of lamination patterns is the quasi-isotropic composite. Here, the repeat pattern in a laminate is $0^\circ - 45^\circ - 90^\circ - 135^\circ$. To avoid coupling of tension and compression with bending, the pattern must be symmetrical, i.e. $0^\circ - 45^\circ - 90^\circ - 135^\circ - 135^\circ - 90^\circ - 45^\circ - 0^\circ$. As shown in Figures 3 and 4, the tensile modulus is constant with orientation whereas the tensile strength varies slightly. The quasi-isotropic laminate layup pattern is directly applicable to what is currently the major potential application of thin composite plates - the shims of sandwich structures used in advanced aircraft and spacecraft. Planar isotropic composites are, thus, directly comparable to fibrous quasi-isotropic composites.

4.2.1 Comparison of Planar Isotropic and Quasi-Isotropic Composites

Filamentary composite materials are generally limited to reinforcement volumes around 50-60%. The absolute upper limit is 78.5% for a square array and 90.7% for a hexagonal array and these correspond to the conditions at which adjacent filaments touch. The practical limit is less, however, to provide a margin of safety and allow for non-uniform filament spacing. By contrast, there appears to be no upper limit for planar isotropic composites; reinforcement volume fractions close to 90% were obtained during this program. Thus, considering a film modulus of 15 MSI and strength of 116 KSI which appear to be realizable values, (Appendix B) a reinforcement volume fraction of 80% and a composite efficiency of 80% yields a composite modulus of about 10 MSI and a strength of about 75 KSI. These values are shown

in Figures 3 and 4 indicating that the properties of graphite planar isotropic composites (also shown are the maximum measured values of 6 MSI and 59 KSI).

Planar isotropic composites have a distinct advantage in terms of minimum gage. This is an important factor in sandwich construction, particularly where weight is an important consideration.

In theory at least a single ply graphite film composite could be utilized having a thickness of 0.0002 to 0.0003 inches; even 4-6 plies would not exceed 0.002 inches. By contrast, the minimum thickness of a balanced quasi-isotropic composite is about 0.040 inches or twenty times the minimum gage of the planar isotropic composite.

One further factor in this comparison is that the strength of graphite composites have been shown by Foesch (9), for example, to decrease with decreasing number of plies. Thus, the strength of one graphite polyimide composite (9) decreased by 36% as the number of plies decreased from 20 to 5.

2.3 Applications of Planar Isotropic Composites

In addition to skins for thin sandwich type structures, planar isotropic composites have been considered for the following applications:

1. Increasing the transverse modulus and strength of uni-directional composites. These hybrid composites were suggested by Halpin and Thomas (10).
2. Reinforcing mechanical joints in filamentary composites. Successful demonstrations performed by Padawer (1, 2) using a boron/polyimide film composite to reinforce a ± 45 degree graphite fiber/epoxy composite.
3. Single ply reinforcement of low strength, low modulus plastics. The flexure tests in this program showed that the addition of about 5% graphite film composite increased the flexural modulus of an acrylic beam by 100%.
4. Reinforcement of structures to reduce high localized stress and/or deflection.

In conclusion, film and fiber composites are generally compared with conventional structural materials on a modulus to density and strength to density basis. This is done on a limited basis in Figure 5. The superiority of composites to steel and aluminum alloys is clearly indicated. The graphite film composite region also compares favorably with graphite fiber composites.

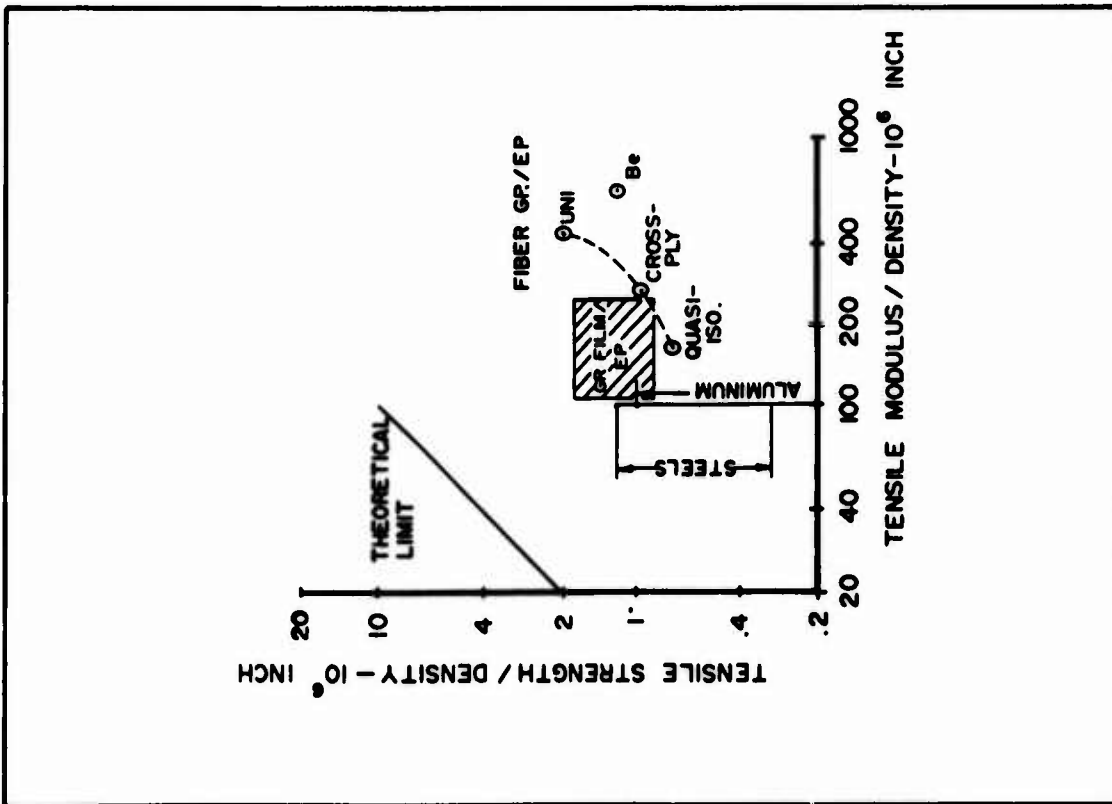

FIGURE 5. COMPARISON OF COMPOSITE WITH ISOTROPIC MATERIALS

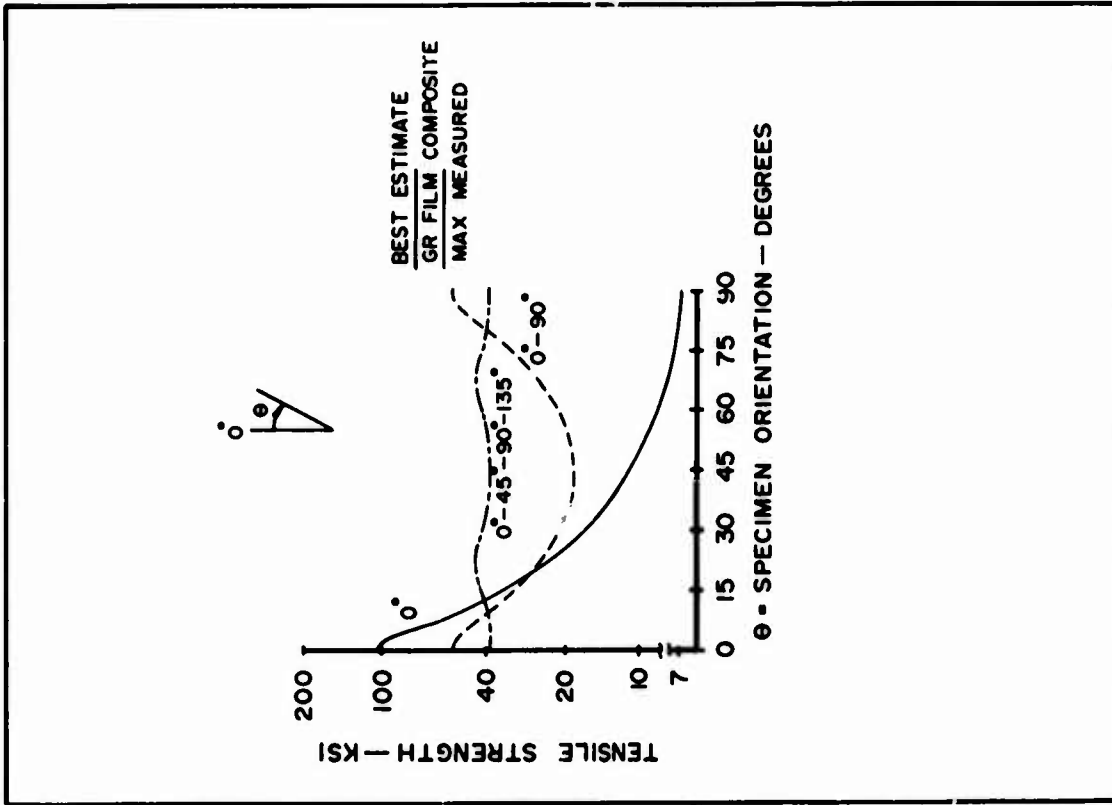

FIGURE 4. VARIATION OF TENSILE STRENGTH WITH ORIENTATION

III. EXPERIMENTAL PROGRAM

The program which was followed in this investigation consisted of four major efforts. These areas of effort were: (1) film preparation; (2) composite preparation; (3) test program; and (4) data analysis. The overall program objective was to demonstrate the feasibility of using pyrolytic graphite film as a reinforcement in polymeric matrix composites.

3.1 Film Preparation

In order to conduct the program, it was necessary to produce the pyrolytic graphite film in sufficient quantity for the necessary test specimens. It was estimated that eight (8) square feet would be prepared with the expectation that a part of this film would prove unsatisfactory for use in composite fabrication.

The film was a nominal 0.3 mils thick and of the best quality achievable within the state-of-the-art. The film was prepared by chemical vapor deposition (CVD) and cut to a standard sheet size (approximately 6.0 x 1.5 x 0.0003-inches) prior to use in the fabrication of composites.

The deposition equipment used to make the graphite film is shown in Figure 6. This equipment consists of an inductively heated reactor which operates at atmospheric pressure. The reactor is in the form of a four (4) inch diameter quartz tube with watercooled brass fixtures. Within the quartz tube is a pyrolytic graphite susceptor which is insulated from the quartz tube by a layer of needled carbon felt. Within the reactor, a rectangular graphite boat served as the area for film deposition. Figure 7 shows the reactor in greater detail with the end cap removed and the boat partially removed from the chamber. It is on this graphite boat that the film was deposited.

Using the equipment shown in Figures 6 and 7, enough material was prepared to satisfy the needs of the program. As noted earlier, this quantity of film amounted to approximately eight (8) square feet.

3.2 Composite Preparation

Because this program marked the first controlled exploration of thin graphite film composites, it was necessary to include in this part of the program certain preliminary tasks such as

bond strength measurements, a determination of film handleability, coating methods, film cutting techniques, and matrix evaluation.

The composites to be prepared in this program task were originally planned to be simple tensile specimens approximately 2.0 x 0.5-inches, with six (6) plies of film reinforcement. Approximately seventy (70) specimens were to be prepared and tested for tensile strength and modulus as well as flexural and compressive properties.

As the program progressed, however, it became obvious that considerable work was required in the area of composite geometry and structure. This part of the program was modified and expanded to include a number of tasks not foreseen in the original program. Detailed discussion of this program task and the results of the work is presented in the next section (4.2).

3.3 Test Program

The test program laid out for this exploratory effort consisted of an evaluation of the tensile properties of the basic film and, separately, an evaluation of the composite specimens.

3.3.1 Film Tests

As the film was being prepared, small tensile specimens were cut from a number of film sheets. These specimens were tested for tensile strength and modulus in both 0° and 90° directions. The test procedure consisted of mounting each film specimen in a "picture frame" holder as shown in Figure 8. After the specimen was mounted in the test machine, the vertical sides of the frame were cut with a hot wire. This method minimized the damage done to the film sample by handling.

Based upon these tests, film was selected for use in the composite fabrication. In addition to tensile properties, a fraction of these film specimens were also checked for micro-structure and density. Approximately one hundred (100) specimens were examined in this phase of the program. The results of these tests are presented in section 4.3.

3.3.2 Composite Tests

Approximately seventy specimens were originally planned to be evaluated in this phase of the

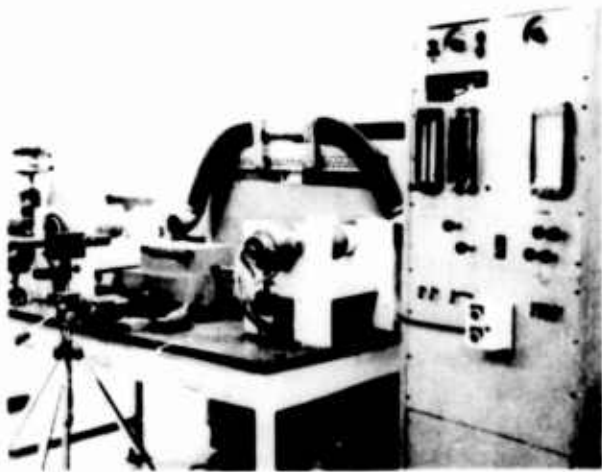

FIGURE 6
FILM DEPOSITION APPARATUS



FIGURE 7
DEPOSITION REACTOR

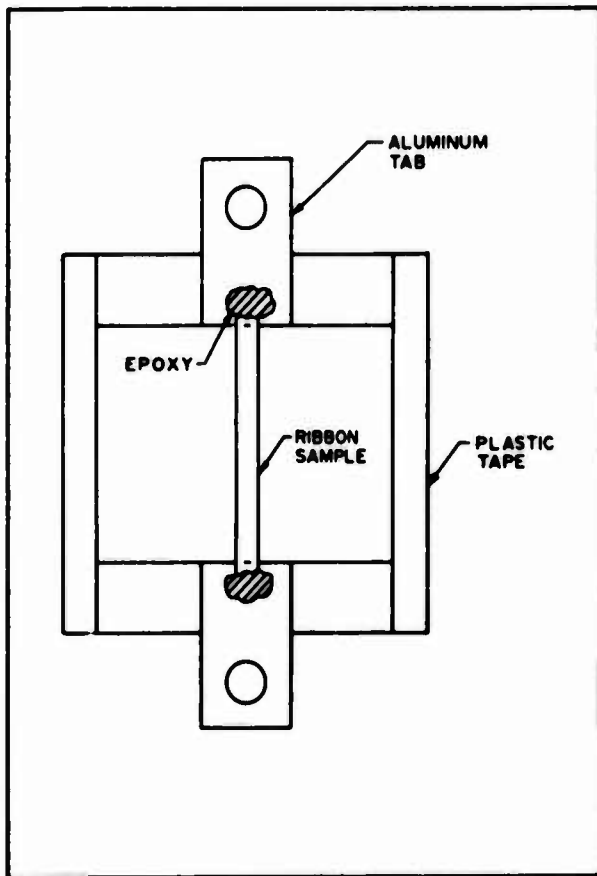

FIGURE 8. FILM SPECIMEN MOUNT

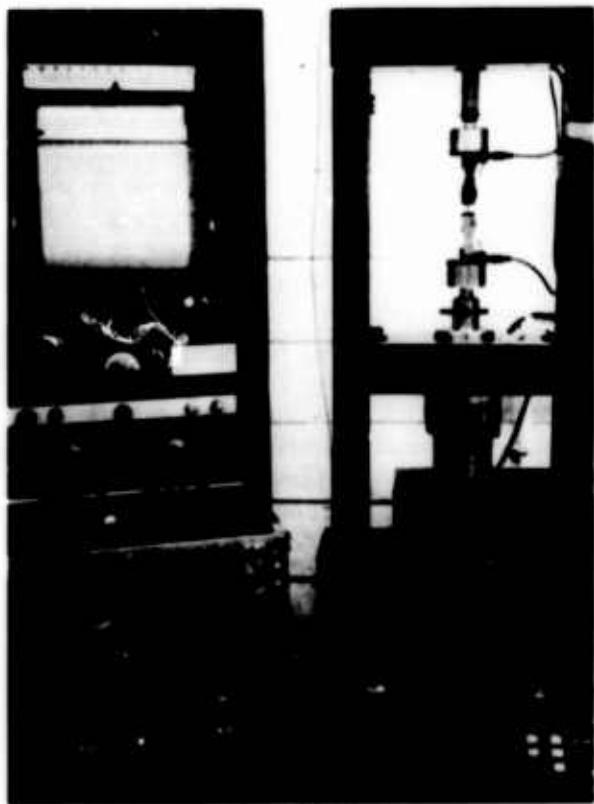

FIGURE 9
INSTRON TEST MACHINE

program. Well over twice that number were actually made and tested. The reason for an increase in the number of tested specimens was that it proved necessary to explore, in detail, a number of variables associated with the composite structure and test method. These variables included volume percent loading of reinforcement, matrix materials, ply geometry (single, discontinuous, parallel strips, perforated, and 0° - 90° orientation), total number of plies, gauge length, specimen width, gripping methods for test purposes, and test procedure.

All tests were run on an Instron machine at Pfizer, Easton. The test frame and associated control console are shown in Figure 9.

In addition to the tensile tests, a small number of tests were performed in which the composite specimen was bonded to the tensile face of an acrylic flexure test bar. The details and results of this test program are given in section 4.3.

IV. EXPERIMENTAL RESULTS

4.1 Film Preparation

After deposition, the film must be removed from the substrate, and in the process of removal the film sheets are easily damaged. This damage usually results in a film sheet with torn or ragged edges. This situation was usually corrected by trimming the sheet to remove such edge flaws. The normal sheet size, after trimming was about 6.0 x 1.5 inches. While the thickness of the film varied from 0.1 to 0.4 mils, the nominal thickness was about 0.3 mils.

The film sheets were free of any carrier film and were free standing. There was a mirror-like appearance to the material and no apparent porosity. Within the film sheets, there were a number of visible ripples perpendicular to the length. These ripples were used as a reference for cutting 0° and 90° film strips for testing and for composite fabrication. The 0° direction was taken as the length of the sheet and this corresponds to the flow direction of the deposition gas.

In most cases, both surfaces of the film sheets appeared identical, although in the case of the thicker films, the last deposited surface (away from the substrates) tended to be grey and not as reflective as the substrate side.

3.4 Data Analysis

The experimental data was analyzed to determine the following points.

1. Average film properties based on a one (1) inch gauge length.
2. The effect of gauge length and load application rates on the tensile properties of the film.
3. The relationship between film properties and composite properties.
4. The efficiency with which ribbon properties could be transferred to the composites.
5. The effect of directional stress (0° , 90°) on the film and composite specimens.
6. The effect of composite geometry on tensile properties.
7. The effect of matrix materials on composite properties.

The method used as well as the results of this analysis are given in section 5.

Because the film was completely unsupported, it tended to roll up or curl. To prevent this, each individual film sheet was placed in a thin plastic case. This packaging also protected the film from being damaged and facilitated the storage of the material during this phase of the program.

Examination of the film cross-section at 400x and 600x revealed that at a thickness of 0.2 mils or less, there were no noticeable growth cones in the microstructure. Above 0.2 mils, some growth cones were present, and it is suggested that these may account for any noticeable loss of tensile properties at greater film thicknesses.

During this phase of the program, approximately 150 sheets of film were prepared which measured about 6 x 1.5 inches with a nominal thickness of 0.3 mils.

The testing procedure and resulting data are discussed in detail in Section 4.3 and Section 5.

4.2 Composite Fabrication

The following sections describe the methods that were investigated and used to handle the graphite film and fabricate laminates and test samples.

4.2.1 Handling of Graphite Film

Graphite and carbon films are high modulus and high strength reinforcements that will be used in many future structural applications. However, in the original uncoated form, these are thin and fragile materials that require special precautions and handling methods in order to avoid film breakage, minimize edge defects, and to obtain proper film positioning within the laminate. Without these precautions, the resultant composites will have much lower physical properties than the true attainable values.

Small sections of the film should be handled carefully with the use of plastic forceps, such as Fisher Scientific Co., Balance Weight Plastic Forceps, Catalog No. 2-354. Even the use of these forceps can result in film tears, if the film is gripped at the edge by the forcep tips and a bending or twisting force is applied.

Whenever feasible, the graphite film should be placed on a carrier film such as Mylar or Teflon, and the extended edges of Mylar gripped as a means of moving the graphite film. Small urethane foam pads can be placed on the graphite as a means of keeping it from curling, or it may be tacked flat prior to coating by adhering the corners to the carrier film with drops of the uncured polymer coating material. Unlike other thin film materials, the graphite film is not bonded to a carrier film in the manufacture process.

The "as produced" graphite film should not be handled or touched since this could leave an oily deposit that would prevent resin adhesion and result in poor composite properties.

If the film edges are rough or frayed, there will be a tendency for crack propagation from these edges during handling or coating, so that it is best to trim the edges to a straight line. Cutting the dry film with scissors results in many edge flaws; it is best to cut with a guillotine cutter or straight knife edge. The film should be placed on an aluminum plate; a knife edge carefully placed on the line to be cut, and the knife hit with a mallet to cut through the film. Graphite film that has been coated with an epoxy or other polymer will usually form less edge flaws when cut.

In the fabrication of laminates, an intermediate coating step necessitates the use of a release film, which will not adhere to the coating. The release film also acts as a handling support for the gra-

phite film, and as the separator that prevents the cured laminate from bonding to the mold surface. A number of release papers were tested for possible use in this program. These included various products of Warren Paper Co., Patapar Parchment Co., and Appleton Papers, Inc., and Daubert Chemical Co. The Warren papers tested included their Transcote PFR C1S, FER C1S, BV C1S, Patent AV, Stripkote VLP and EZR. The most suitable release paper was Daubert Release Paper 2-65KG-1. However, this material was relatively thick (0.003-inch) and led to occasional tearing of the graphite film when these were separated. The best material for this application has proven to be a cast TFE Teflon film, 0.0005-inch thick, manufactured by Dilectrix Corporation, L.I., N.Y. When separating the Teflon film from a coated graphite film or laminate, it is recommended that the graphite be kept supported on a flat surface and the Teflon film peeled off while maintaining a small radius.

4.2.2 Graphite Film Coating

There are a large number of methods that are used industrially for the application of coatings. The spray coating of a polymer solution is a convenient way to obtain a uniform coating thickness. Many commercial reinforcement fabrics, such as glass cloth, are coated by use of a dip tank in a continuous process where the resultant coating thickness can be controlled by factors such as adjusting the solution concentration. This would probably be the preferred method for applying a resin coating to the film at a future date when it is produced in continuous lengths. For small scale laboratory investigations, a convenient method for obtaining a uniform thin coating on a substrate is the knife coating procedure. This method is illustrated in Figure 10. A Teflon film was wrapped onto a glass plate in a manner that avoids the formation of wrinkles. The graphite film was tacked onto the Teflon by placing small drops of uncured resin under the corners of the film. A small amount of resin was then placed along one edge of the graphite, and the knife edge was drawn across the film as shown in the Figure 10. During this procedure, the knife edges rest firmly on the 0.001-inch shims and a smooth continuous movement results in a thin uniform coating. After coating, the knife and shims were removed, and the overlapping ends of Teflon were used as a

PLACE A FINGER IN (3)
APPROX. AREA. HOLDING
FIRMLY, DRAW KNIFE
ACROSS SHIMS IN DIRECTION
OF ARROW

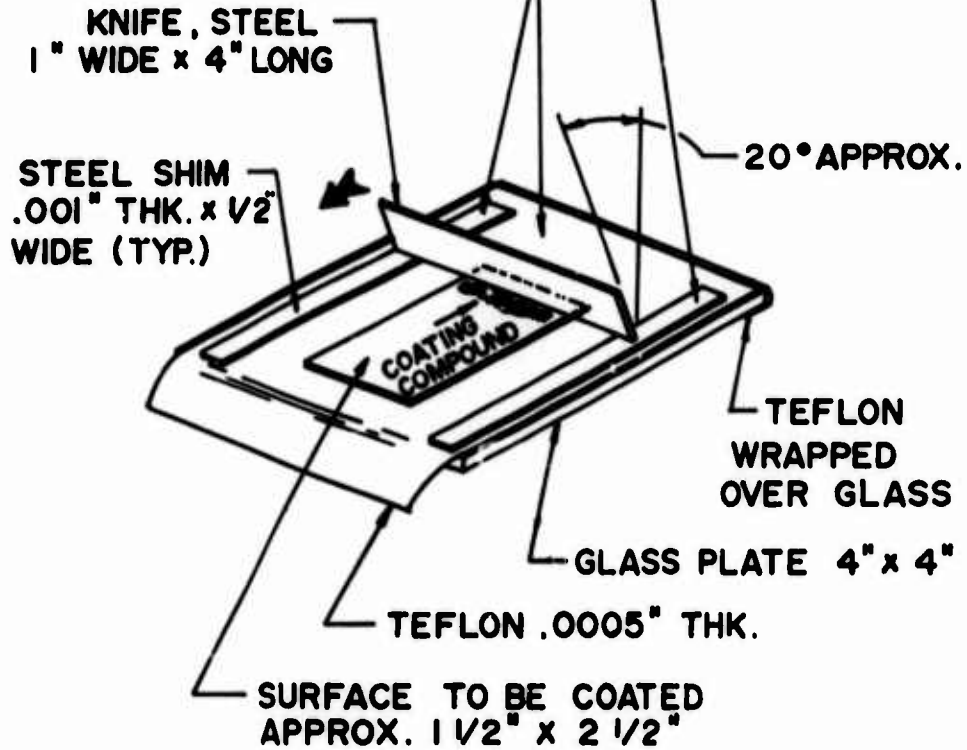

FIGURE 10. KNIFE COATING SETUP

carrying and handling means to carefully transfer the graphite film onto a second Teflon covered glass plate. The first Teflon film was then carefully peeled off, and the second side of the graphite film was knife coated as described above. The coated graphite film was then placed onto a preform laminate stack, or carefully covered with a top sheet of Teflon film and cut into uniform width strips as described in the later Section 4.2.6.

4.2.3 Polymer Matrix Materials

Table 1 is a list of the matrix materials that were used to make the test laminates:

TABLE 1
Matrix Materials

- A. Ciba Araldite 6004 Epoxy Resin + 20 PHR Shell Catalyst Z.
- B. Ciba Araldite 6044 Epoxy Resin + General Mills Versamide 140; Equal parts by weight.
- C. Ciba Araldite 6004 + Hexahydrophthalic Anhydride (70 PHR) + Argus DB-VIII (2 PHR).
- D. Union Carbide ERLA 4617 Epoxy Resin + m-Phenylene diamine (25 PHR) + BF_3 - Monoethylamine (1.5 PHR). E4MB
- E. DuPont Adiprene 315 Urethane Resin + MOCA Catalyst (26 PHR).

Each one of these polymer systems has its advantages and disadvantages. Matrix B, is convenient to use since it can be cured at room temperature (overnight), or within $\frac{1}{2}$ hour at 180° F. Also, the Versamide resin can be used at higher or lower ratios and still yield a good cured product, and it is less likely to cause a dermatitis reaction as is often the case with other epoxy curing agents. Primarily because of its low temperature cure, and because of an early concern that the thermal expansion of the graphite might lead to some debonding on cooling from higher temperature cures, Matrix B was used for many of the early test laminates. However, this is not the type of matrix that is used in high performance composites, where an epoxy with a higher modulus and one that can be "B" staged is preferred. Matrix systems that have received favorable attention recently for advanced composites have been based on the high performance epoxy resin ERLA 4617, manufactured by Union Carbide Corporation. Formulations based on this resin yield physical properties that are considerably above those

of conventional epoxy resins, such as a modulus of 0.7 MSI and tensile strength of 18 KSI, as compared with conventional epoxies at 0.5 MSI modulus and 10 KSI tensile strength. Matrix D was formulated with ERLA 4617, and Matrix A is the more conventional type of epoxy matrix that has been used in reinforced plastics components. Matrix D must be cured at a relatively high temperature; in this program a stepwise cure to 470° F was used, and this may be the reason that lower composite physical properties were obtained than those with Matrix A.

Matrix A laminates were subjected to a final cure at 300° F. The anhydride cure, Matrix C, was tested to determine if this curing agent might lead to improved composite efficiency. In an initial comparison of Matrix A and C with the same Pfizer Film No. 316, the Matrix C resulted in higher properties. However, subsequent laminates with Matrix C did not yield as high absolute physical properties as those obtained with Matrix A, which has led to the highest current values. Matrix C was cured at 325° F. Matrix E, which is a rigid urethane elastomer, which was tested in only a few samples to determine if a tough higher-elongation matrix might be utilized for film composites.

4.2.4 Laminate Molding

Essentially three different procedures were used to produce the test laminates. These were flat plate molding, multi-cavity molding, and enclosed panel molding.

- A. Flat plate molding. This method is illustrated in Figure 11. The graphite film was coated in the manner described in Section 4.2.2, and the desired number of plies was stacked together as an uncured preform. Before placement of the top ply, two steel shim strips were placed parallel to the sides of the laminate as a means of trying to control the final thickness of the laminate. After placement of the last ply, strips of a urethane foam were placed along the outer borders of the laminate in order to prevent any of the graphite film plies from sliding out of the stack when the molding pressure was applied. The use of wrinkle-free Teflon film, good surface quality release paper, and chrome plates were essential to maintain a good surface finish on the molded



FIGURE 11. FLAT PLATE MOLDING

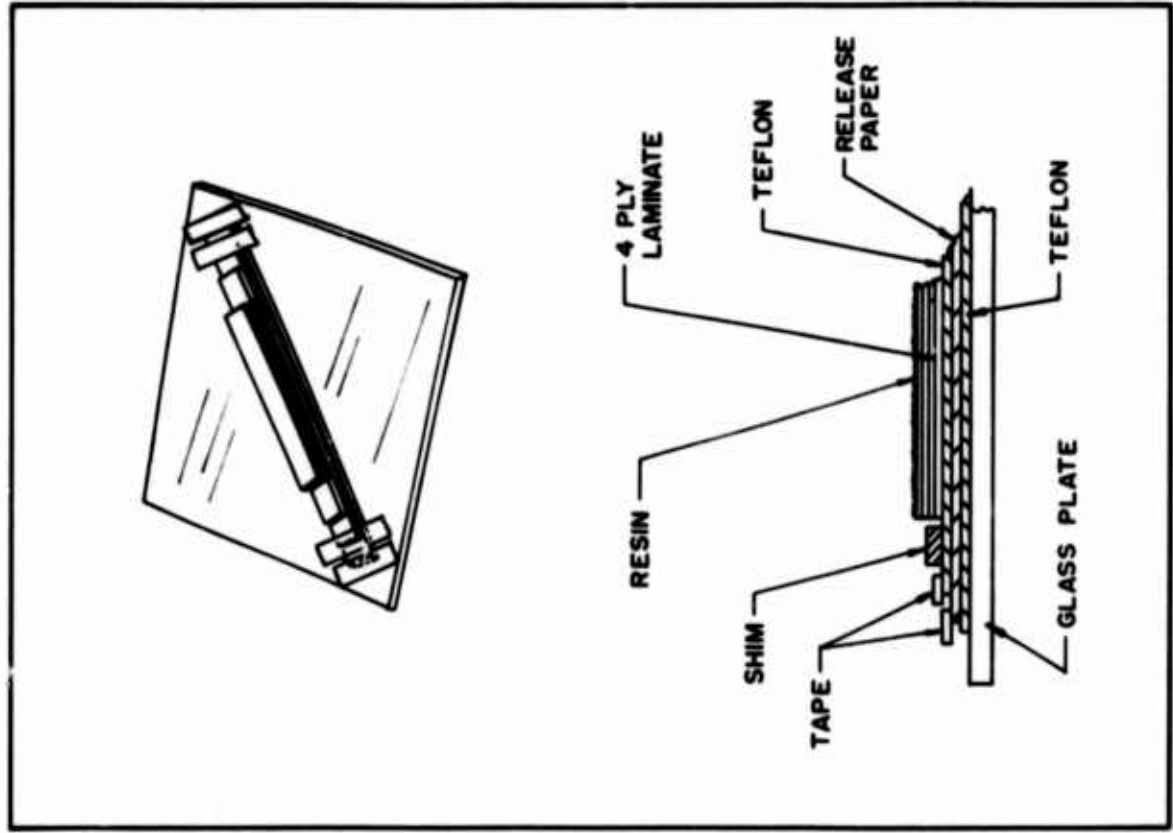

FIGURE 12. LAMINATE PREFORM BUILDUP

laminate. By this method, large area laminates could be produced and, later, cut into a number of smaller panels by the use of steel rule dies. The disadvantages of this method are that in spite of precautions, there may be some movement of the graphite film during molding, and this displacement or any other defects in the laminate will result in composites with poor structure and/or properties. Also, when this type of cured laminate is cut, the edges of the strip are trapped momentarily between the two tapered cutting edges and may be bent sharply and delaminated. Examples of laminates made by this process were a number of the T prefix series, such as T5 and T8 and several test samples were cut from each of these laminates.

B. Multi-cavity Open End Molds. Most of the test samples were prepared by this procedure, as described below.

The graphite film was coated as described in Section 4.2.2, and cut into $\frac{1}{4}$ -inch wide strips as described in Section 4.2.6.

The preform was constructed on a 4" x 4" glass plate. A piece of Teflon film, 1" x 4", was set across the center, and the two sheets were taped in position at the edges, as shown in Figure 12.

The coated graphite film, cut into strips as described previously, was placed on a separate glass plate, and the Teflon was carefully pulled off one side of the coated graphite. In order to avoid damage to the graphite film, it was kept flat, while the Teflon film was peeled off. A small bend radius was maintained so that the graphite film did not tend to lift up while the Teflon was being removed. This is shown in Figures 13 and 14.

The coated graphite film was placed on the preform base, using the ends of the extended Teflon film as a handling means, and placed onto the release paper strip with the epoxy coated side up. Masking tape was placed on the ends of this strip to hold it in place. The top Teflon was peeled off a second coated graphite strip, which was then placed carefully onto the first preform strip, but with the Teflon film on top. The Teflon was carefully peeled off. The later procedure was repeated until the desired number of plies was built

up. In this program, the number of plies per specimen ranged between 2 and 8, with most samples containing 4 or 6 plies. Before securing the last ply, an aluminum shim was placed at the two ends of the preform, as shown in Figure 12. The shim was intended as a means of controlling the volume percent of graphite in the final laminate. The shim dimensions were approximately $\frac{1}{4}$ x $\frac{1}{2}$ inch, and the thickness was chosen to yield a laminate with approximately 50 volume % of graphite film or about 0.6 mil per ply. In early moldings, it was noted that the final laminates were thinner than the shims, so a shim thickness of about 1 mil per ply was used. When the final ply of graphite was in place, the covering Teflon film was retained. Finally a $\frac{1}{4}$ " wide strip of release paper was placed on the assembly and a 1" x 4" piece of Teflon. Care was taken throughout the preforming so that the $\frac{1}{4}$ " wide strips of graphite film were maintained in a good edge alignment.

The laminate mold is shown in Figure 15. The masking tape strips were carefully peeled off or cut off the preform; a mold plunger was then placed onto the preform so the edges coincided with the $\frac{1}{4}$ " wide strips, the overlapping Teflon was lifted along the sides of the plunger and the assembly placed into a mold cavity, as shown in Figure 16. Figure 17 depicts the cross-section of this assembly as it was set into the mold cavity.

After all five preforms and plungers were set into the mold cavities, a sheet of silicone rubber, about 0.1-inch thick, was placed over the plungers to provide equal pressure distribution and the assembly was placed between the heated platens of a hydraulic press. A molding pressure of about 100 psi was used. The initial molding temperature was usually 225°F and was increased stepwise at a rate of about 25°F every 15 minutes until the final cure temperature was reached. The mold assembly was maintained at the final cure temperature for 1 hour. The specific cure temperature used was a function of each particular matrix. The matrices and cure temperatures were: Matrix C, 300°F; Matrix D, 325°F; and Matrix E, 400°F.

The advantage of using this molding proce-

ture was that five test laminates with varying numbers of plies and structure could quickly be molded from a single Pfizer graphite film sheet. Thus, the basic film thickness and quality could be held constant, and the effects of other variables such as composite structure or number of plies on composite efficiency, could be tested.

A disadvantage of this molding procedure is the need for precise edge alignment of each narrow ply. Such precise alignment cannot be consistently maintained so that edge defects occur, which often make it desirable to cut these samples with a steel rule die to a narrower width.

- C. Enclosed Panel Mold. The mold used for this procedure is shown in Figure 18. All of the thin strip laminates were made using this method. An advantage of this mold is that it restricts the movement of graphite film much better than the previous methods. A disadvantage is that only one test sample can be molded at a time.

Figure 19 shows the different laminate structures which were tested. The F structure or full ply contained plies of graphite film that were shown in the sketch, and the Tile laminates were discontinuous, as indicated, along the length of the graphite film. The purpose of the strip and tile structures was to determine to what extent factors such as edge defects, crack arrestors and the cross strip structure (which would be required for large components) would influence composite properties and mode of failure.

4.2.5 Bonding End Tabs on Tensile Test Specimens

A frequent problem in tensile testing of high modulus materials is the occurrence of sample failure at the gripping jaw edge, which results in low and invalid test results. In order to avoid stress concentration at the jaw edge, tensile testing of advanced composites is usually done by bonding tabs onto the ends of straight panel test specimens. In the case of boron filament test panels, fiberglass tabs are bonded to the ends. The tabs are tapered at an angle near the gage section of the test panel.

The basic configuration of the tensile test sample that was used in this program is shown

in Figure 20, although many samples had a shorter gage length with widths of 1/4-inch and 1/6-inch. The tab material was 0.020-inch thick high impact polystyrene. The tabs were cut from sheet material by the use of steel rule dies, and one end of each tab was tapered by the use of 220 grit sandpaper. The tab surface to be bonded to the laminate was roughened with 80 grit sandpaper and cleaned with acetone.

The tab bonding fixture shown in Figure 21 was used to bond the tabs onto the laminate panels. As shown in the sketch, quadrille paper was used beneath a 0.020-inch thick polypropylene sheet in order to permit visual alignment of the tabs. The bonding adhesive consisted of approximately equal volumes of Ciba Araldite 5004 Epoxy Resin and General Mills Versamid 140 resin. The tab was bonded and cured on one end of the test panel before repeating the procedure on the other end. Note in the cross-section view of Figure 21 that a rigid metal or plastic strip is used within the bonding clamp in order to distribute pressure evenly over the bonded area, and a polypropylene strip is used to prevent bonding of the tab to either the clamp or metal strip. The adhesive was usually cured overnight at room temperature, although cure may be accomplished in 1/2-hour at 180°F.

The experimental results show that the use of these tabs has successfully led to satisfactory breaks within the gage length of the tensile specimens.

4.2.6 The Use of Steel Rule Dies

In experimental work with advanced composites, it is often necessary to build up a number of layers of unidirectional prepreg, prepreg fabric, or film. Each layer must usually be cut in a precise pattern. In most future projects, and in large scale production programs, this objective will be met with the use of recently developed sophisticated tape-laying machines. Currently, the best lab method involves the use of steel rule dies. Details on the construction and use of steel rule dies are given in (4).

Steel rule dies, and the similar clicker dies, have been used for many years in the shoe industry and clothing trade to cut production patterns. United Shoe Machinery has a press designed to cut patterns up to about 4-ft. x 2-ft. in size and in cycles of less than 30 seconds.

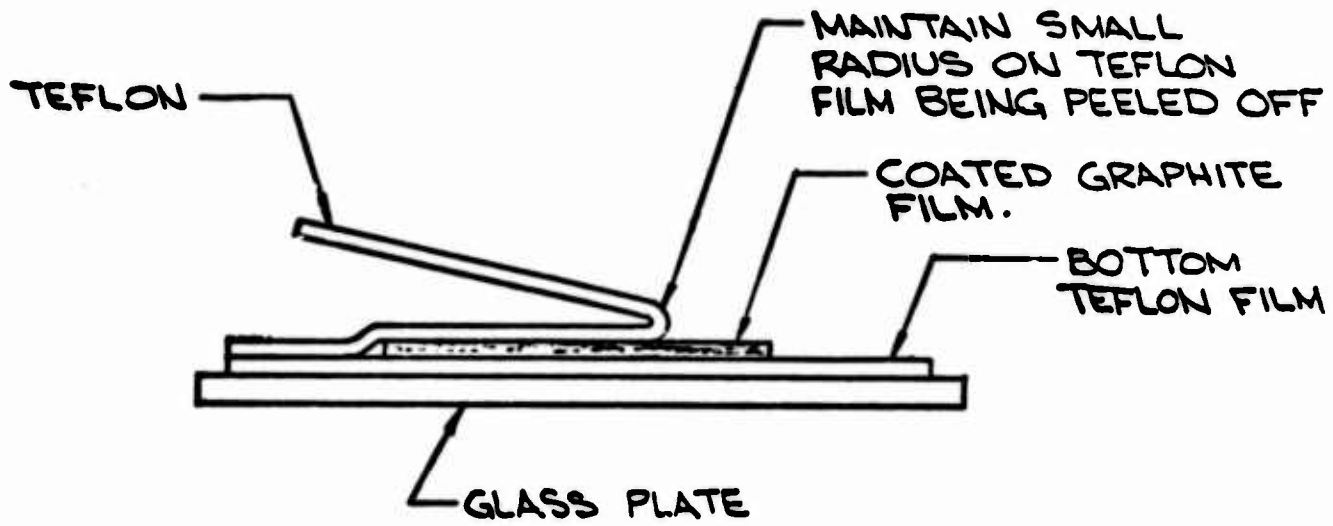

FIGURE 13. TEFLON FILM REMOVAL

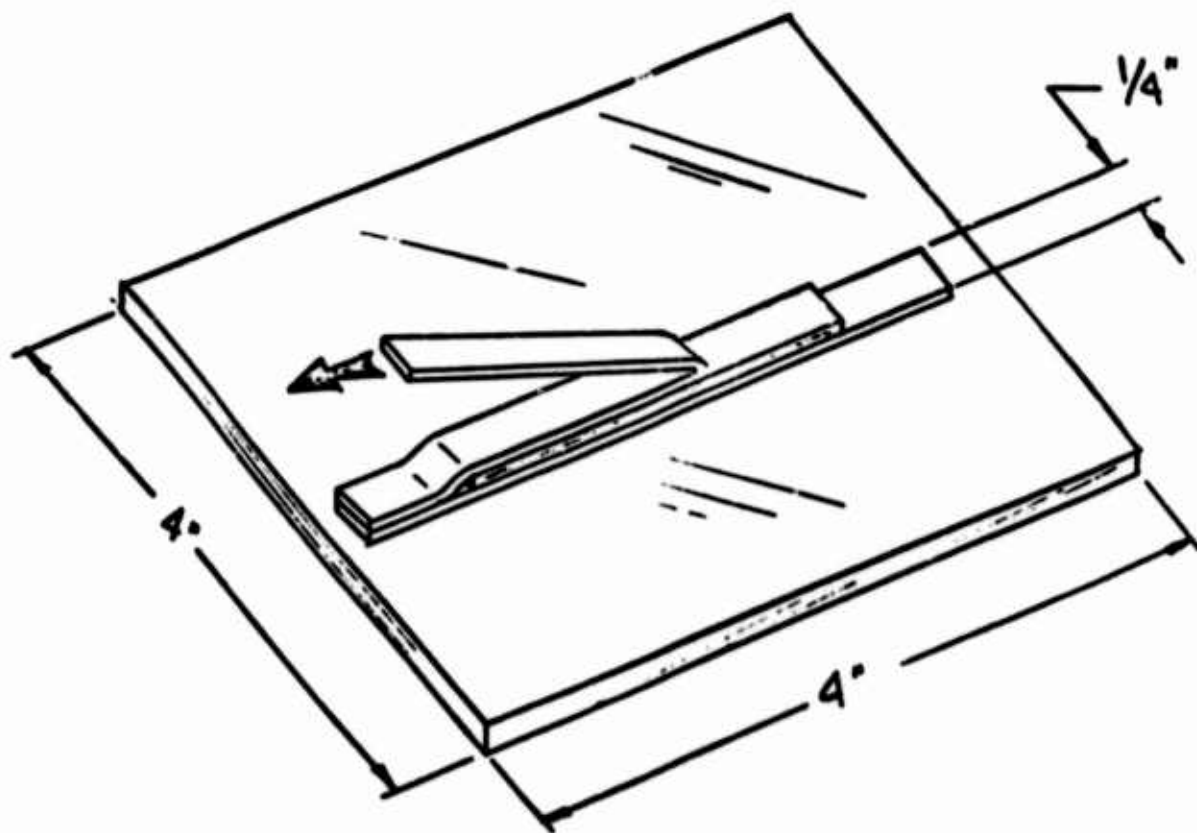

FIGURE 14. TEFLON FILM REMOVAL

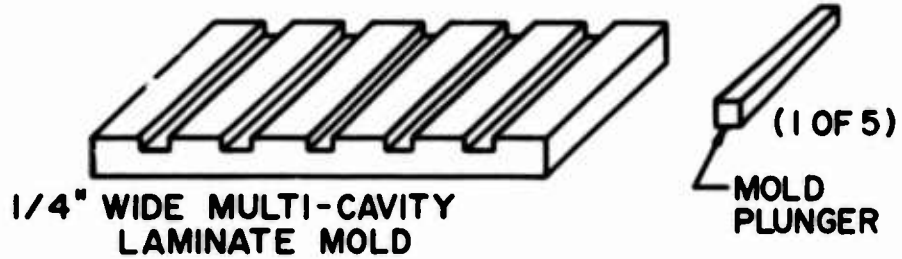

FIGURE 15. MULTI-CAVITY MOLD

FIGURE 16. LAMINATE PREFORM

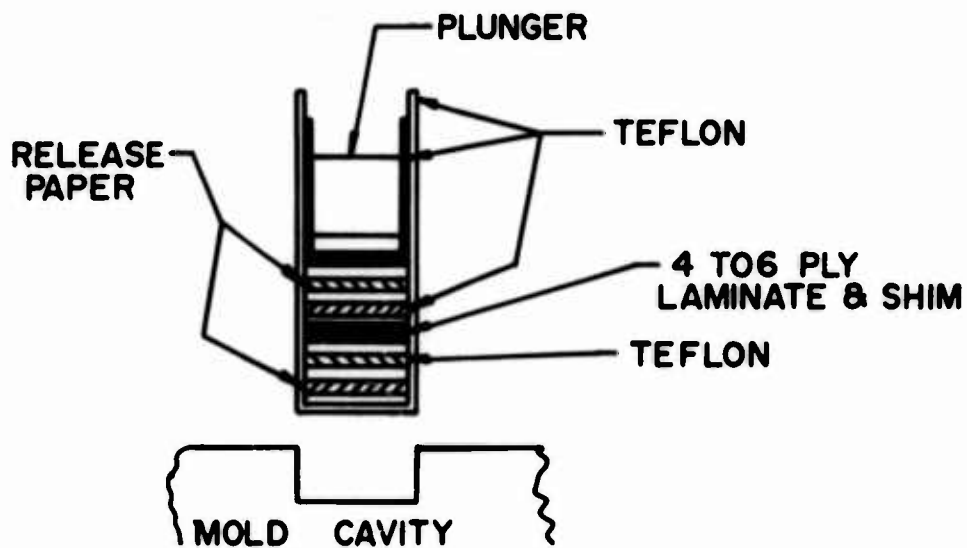

FIGURE 17. ENLARGED VIEW LAMINATE CROSS SECTION

FIGURES 15., 16. & 17.

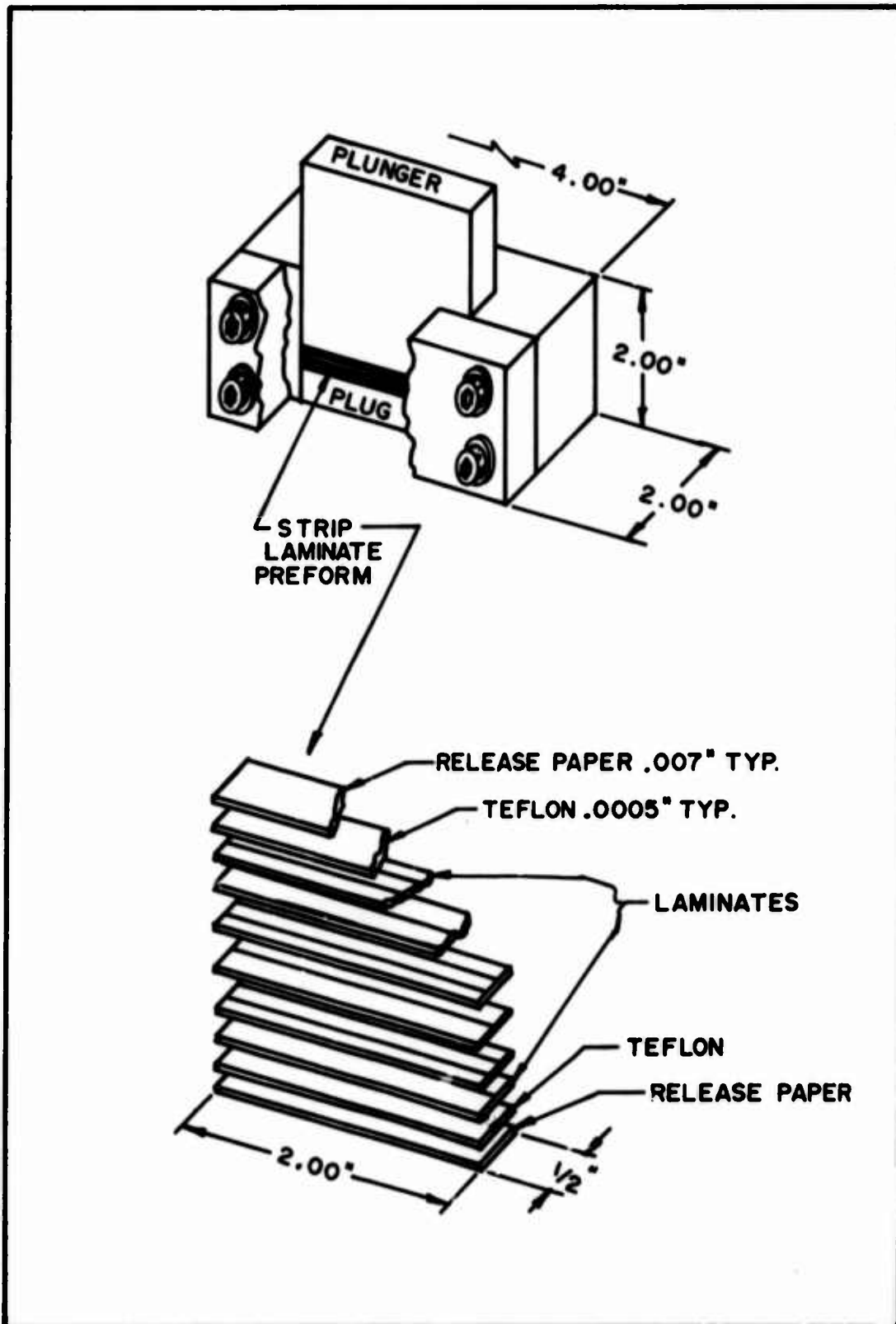
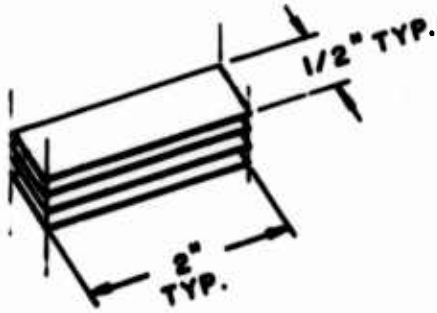
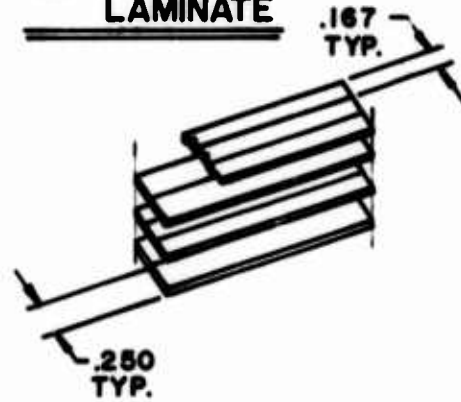

FIGURE 18. ENCLOSED PANEL MOLD

F - FULL PLY



S - STRIP LAMINATE



TS - THIN STRIP LAMINATE

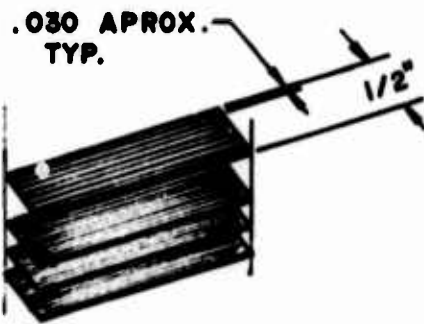

T-1/2 - TILE STRUCTURE 1/2"

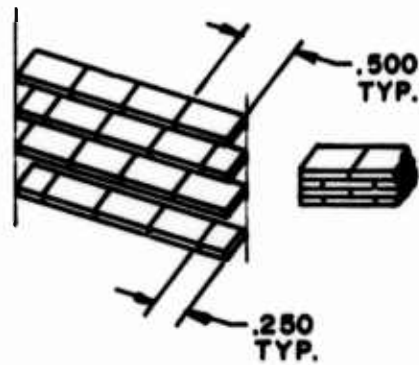

P - PERFORATED INNER PLYS

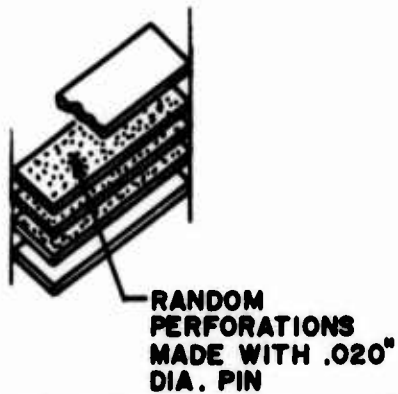

T-1/4 - TILE STRUCTURE 1/4"

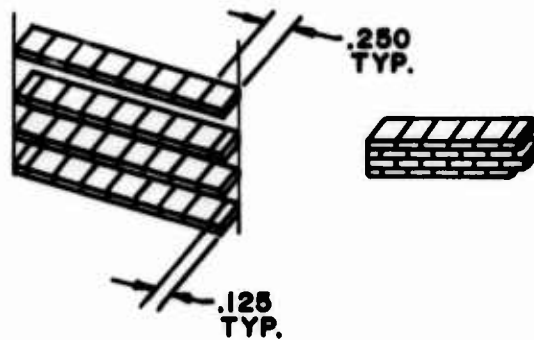

FIGURE 19. TEST LAMINATE STRUCTURES

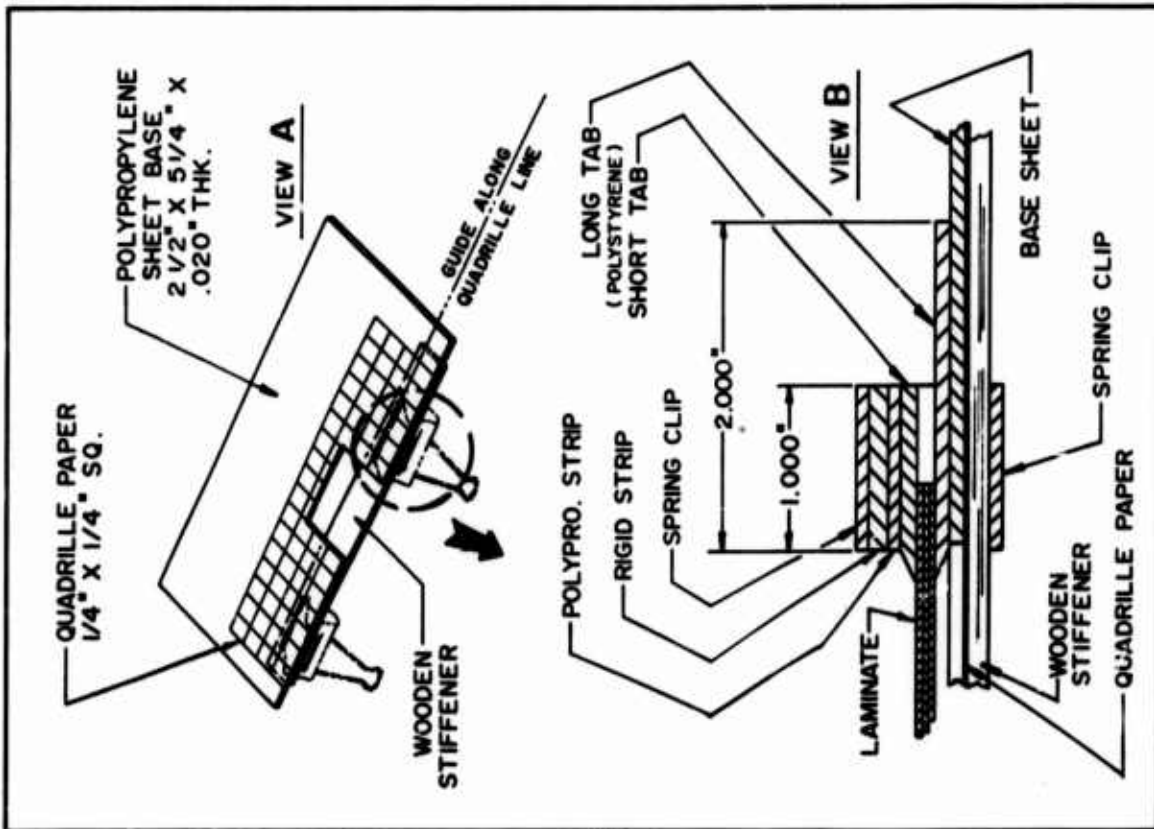

FIGURE 21. TAB BONDING FIXTURE

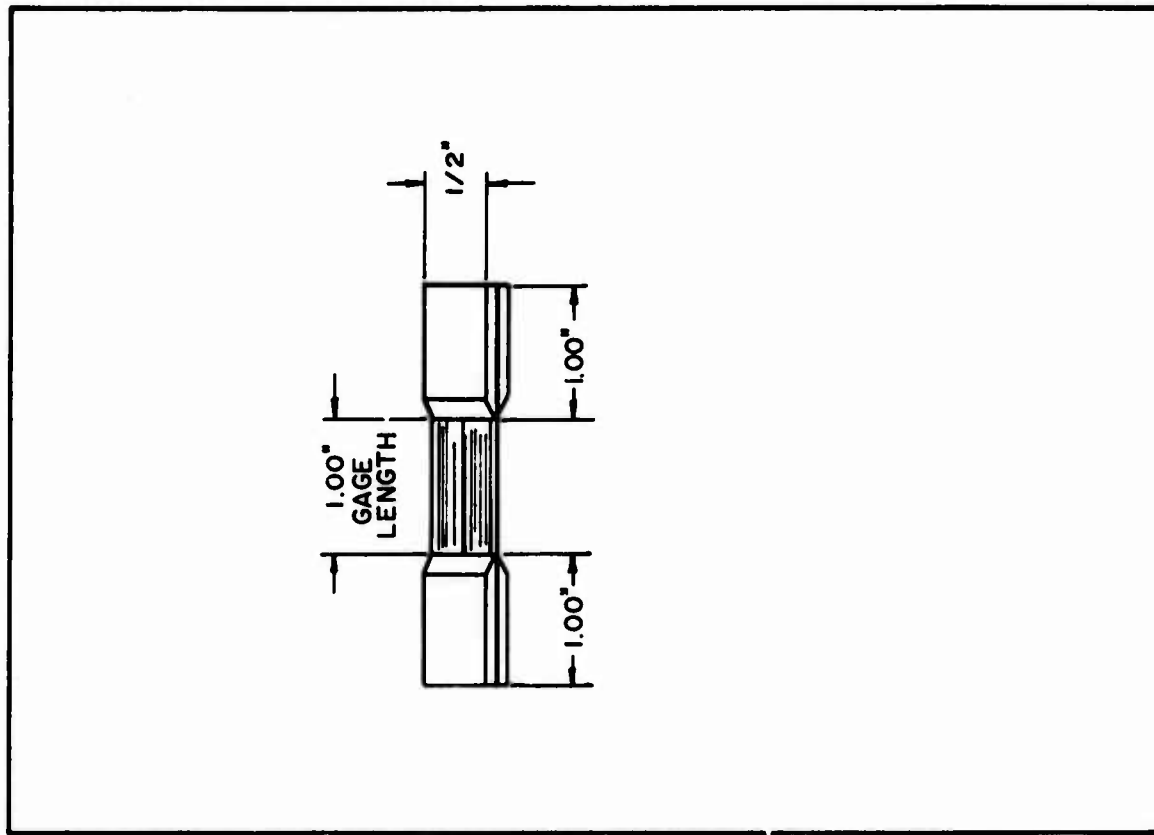

FIGURE 20. TABBED TENSILE SPECIMEN

The steel rule die can be used in a laboratory hydraulic press. Care must be taken that the cutting edge is not pressed directly against the hardened metal platen of the press, or the cutting edge may be dulled. Therefore, a back-up plate is used opposite the steel rule cutting edge. The back-up plate may be plywood, plastic, or an aluminum plate.

The amount of pressure or force that will be required to cut through the film or fabric, will depend on the linear inches of cutting edge in the die, and on the material being cut. The force may be about 150 lbs. per linear inch, and the strip dies used in this program have required about 6,000 lbs. force to cut cleanly through the film. Excessive force should not be used, since the cutting edge is tapered and the film is being pushed into a narrower channel and tends to fold or wrinkle.

The basic steel rule material is available in a number of different styles. The type that has been used in our dies is 2-point, .937-inch wide, #70. This is set into a plywood base that is $\frac{5}{8}$ -inch thick. Inside the cutting area, we request that the die manufacturer place a smooth surface foam rubber, with the upper surface flush with the cutting edge.

In using the die, a layer of .0005-inch Teflon film is placed on the foam, then the Teflon film containing the coated graphite film is fixed in the desired position by use of a piece of masking tape at two edges. Another layer of Teflon film is inserted and finally the aluminum back-up plate. This setup is placed in the hydraulic press, and the appropriate cutting pressure is applied. The assembly is then carefully removed from the press, and the composite strips are removed.

4.3 Mechanical Testing

The minimum mechanical properties required to evaluate a composite material are: elastic modulus in tension and compression, shear modulus, Poissons ratio, strength in tension and compression, and shear strength. In the case of a filamentary composite these properties are measured parallel and perpendicular to the filament direction. The properties of a given layup or filament orientation pattern can then be estimated using the techniques of macromechanics. As a film composite is basically isotropic these analytical

procedures are not required and the material evaluation program becomes much simpler.

The properties considered to be most indicative of the potential of graphite film composites at this stage of their development are their tensile modulus and strength. Accordingly, the test program concentrated on these properties. Additional consideration was given, however, to a "sandwich type" flexure test as a reliable alternate to a tensile test.

4.3.1 Composite Tensile Tests

4.3.1.1 Specimen Geometry

Tensile test specimens for this program were based on recommendations by the Air Force Material Laboratory for filamentary composites (12). Figures 22 & 23 are photographs of a typical composite specimen. It is rectangular in shape, approximately 3 inches long, one-half inch wide, and 0.003 inch thick corresponding to about six plies with polystyrene tabs bonded to each end. During the course of this program, specimen width, number of plies, and specimen structure were varied.

The purpose of the end tabs is to transmit the load from the test machine jaws to the specimen by shear at the tab-composite interface without damaging the outer composite layers. The tabs were one inch long, 0.020 inch thick with a 15° bevel at their intersection with the composite to reduce stress concentration at this point. The tab length is such that the tab/composite contact area multiplied by the adhesive shear strength exceeds the maximum tensile load.

4.3.1.2 Data Reduction

The tensile strength and modulus were deduced directly from the Instron plot of load vs. cross-head travel. Figure 24 is a sketch of a representative load-elongation plot. As cross-head speeds of 0.005 inch per minute and chart speeds of five inches per minute are typical, one inch along the abscissa represents a 0.001 inch cross-head travel.

The ordinate, representing tensile load, is scaled in accordance with the Instron load range being used—two pounds full scale for film testing and ten pounds full scale for composite testing are typical. The scale is thus in the 0.2 to 1 pound per inch range.



FIGURE 22
TENSILE SPECIMEN BEFORE TEST

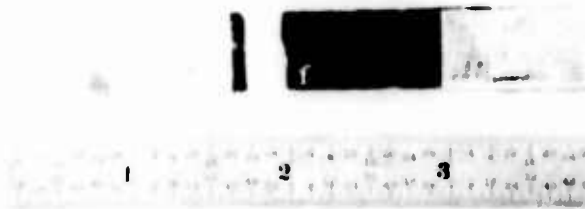

FIGURE 23
TENSILE SPECIMEN AFTER TEST

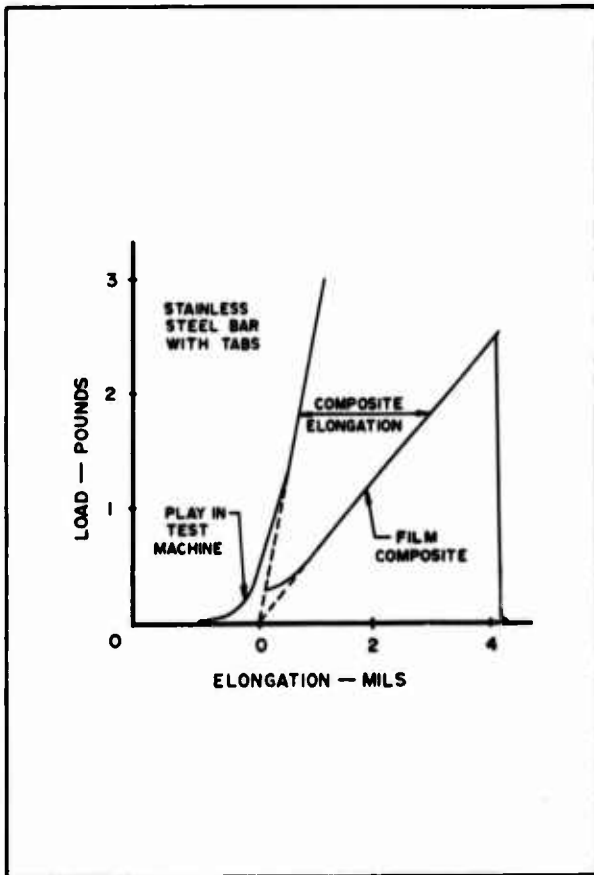

FIGURE 24. CORRECTION OF LOAD-ELONGATION CURVE

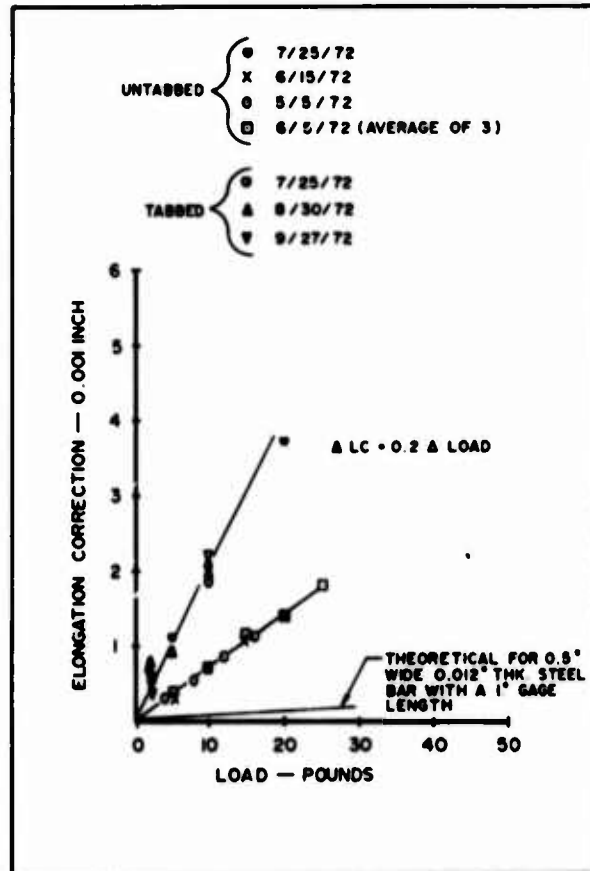

FIGURE 25. TESTING MACHINE CALIBRATION

In addition to test specimen elongation, cross-head travel includes any slack or play in the cross-head mechanism, slippage of the specimen in the jaws, and shear deformation between tabs and specimen. Slack occurs when the load is applied; it appears as the concave upward portion of the curve at low loads. As a result, the true origin of the load-elongation curve is not the origin of the Instron plot. The true origin is located by extending the initial linear portion of the curve to zero load as shown in Figure 24. The effects of jaw and tab slippage on specimen elongation are compensated for by measuring the load-cross-head travel characteristic of a rigid stainless steel bar tabbed similar to the composite test specimen. A typical plot is shown in Figure 25. At a given load the true specimen elongation is the difference between the two curves referenced to the same origin.

The relative magnitudes of jaw slippage and tab slippage are demonstrated in Figure 25. Data for these curves correspond to near full-scale loads for 2, 5, 10 and 20 pound load scales. The lowest curve corresponds to the load-elongation curve for a plain steel bar similar in dimensions to the calibration bar. The second curve includes the effect of jaw slippage and the upper curve includes jaw and tab slippage. The agreement of similar data obtained with different specimens at different times within this program attests to its applicability in transforming cross-head travel into true tensile specimen elongation. Based on this data, the following linear equation was assumed for the correction of all composite strain calculations,

$$\Delta L_c = -0.20 \Delta F$$

Tensile specimen failure was defined as those conditions producing the maximum load, FMAX. The corresponding tensile strength TS is therefore,

$$TS = FMAX/Wt$$

Where W and t are the test specimen width and thickness. The width was measured with a micrometer and was nominally 1/2", 1/4" or 1/6" for the specimens tested. The composite thickness was also measured with a micrometer; corroboration of any questionable value was made using the thickness measured from the corresponding 400x photomicrograph.

Failure strain ϵ corresponds to the elonga-

tion at the failure load and is given by,

$$\epsilon = L \cdot \Delta L_c / L_0$$

Where L_0 is the gage length, assumed to be the distance between the tab/specimen intersections and ΔL_c is the correction which corresponds to the failure load FMAX.

The elastic modulus E is deduced from the slope of the linear portion of the load-cross-head travel curve. This slope is readily obtained from the straight line used to define the origin. Although many curves were linear over their entire range, a number were non-linear near failure, and some were non-linear over most of the load range. Non-linearities were also introduced if one or more films failed prior to reaching the maximum load point. This generally resulted in a change in slope. More will be said about failure types in the following section.

The elastic modulus is thus given by,

$$E = \frac{\Delta F}{Wt} \cdot \frac{L_0}{\Delta L \cdot \Delta L_c}$$

Where ΔL corresponds to ΔF over the linear portion of the curve; ΔF was typically taken as 1 to 5 pounds to obtain reasonably large ΔL values.

4.3.1.3 Tensile Failure Types

Figures 26 to 30 were traced from load-elongation curves representative of the types of composite failure observed during this program. Referring to the tables in Appendices C and D, the letter C refers to catastrophic failure, whereas the letter P refers to progressive failure. Approximately 60% of the composites tested failed catastrophically.

In the case of catastrophic failure, as illustrated in Figure 26, all plies are uniformly strained and fail simultaneously if they are cut from the same sheets of graphite film of uniform properties. If the plies are of different film properties, catastrophic failure occurs if the plies remaining after the weakest ply fails cannot support the additional per ply load. Similarly, if identical plies are not uniformly strained in a tensile test due to a low modulus matrix or poor adhesion between matrix and film, the most highly strained

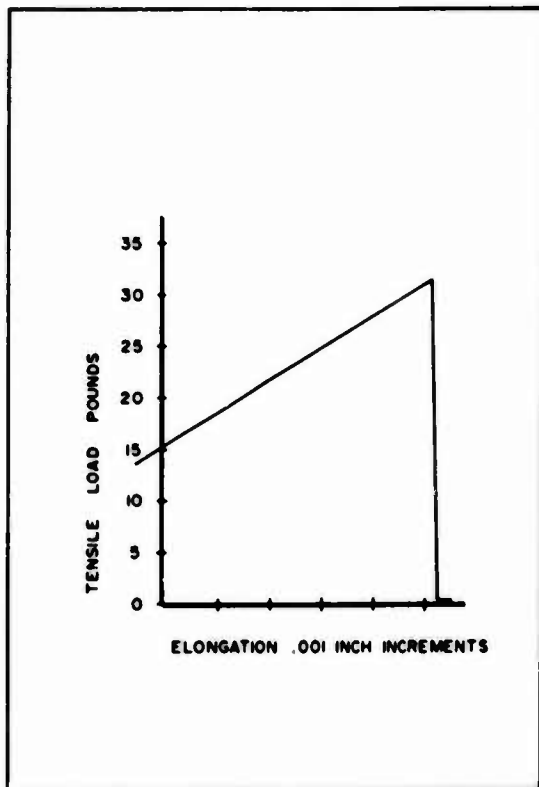

FIGURE 26.
LOAD ELONGATION NO. T-14-A

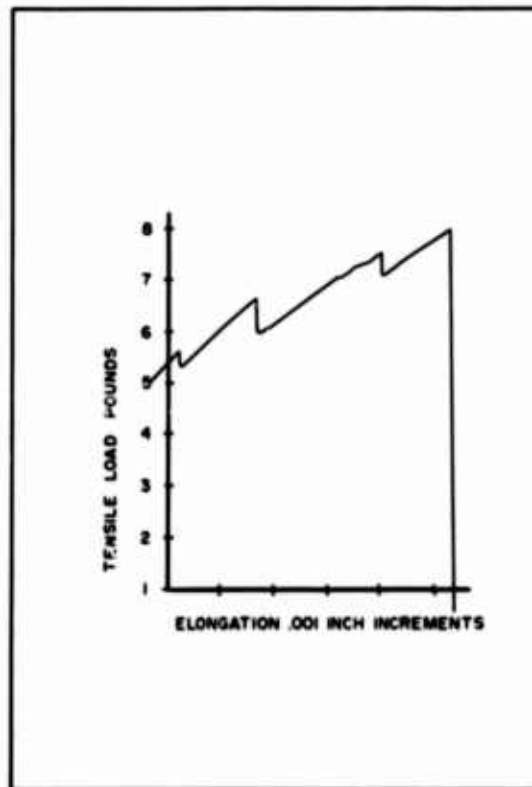

FIGURE 27.
LOAD ELONGATION NO. 318-4

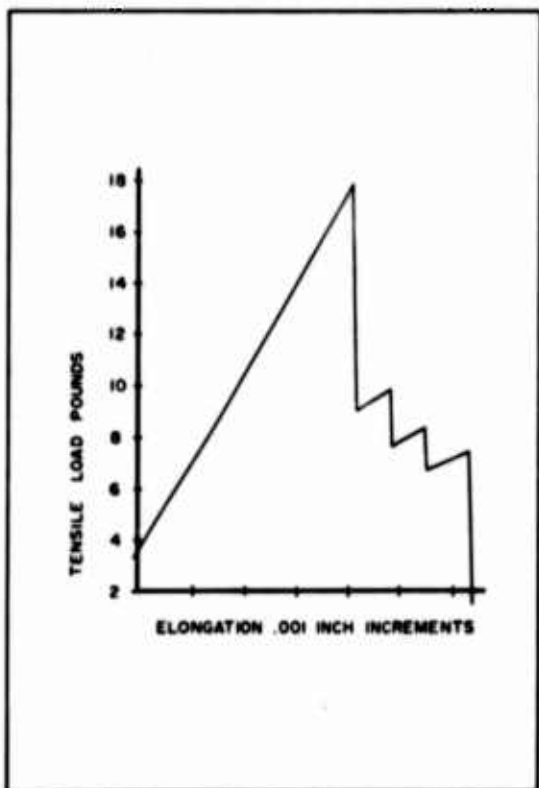

FIGURE 28.
LOAD ELONGATION NO. 316-4

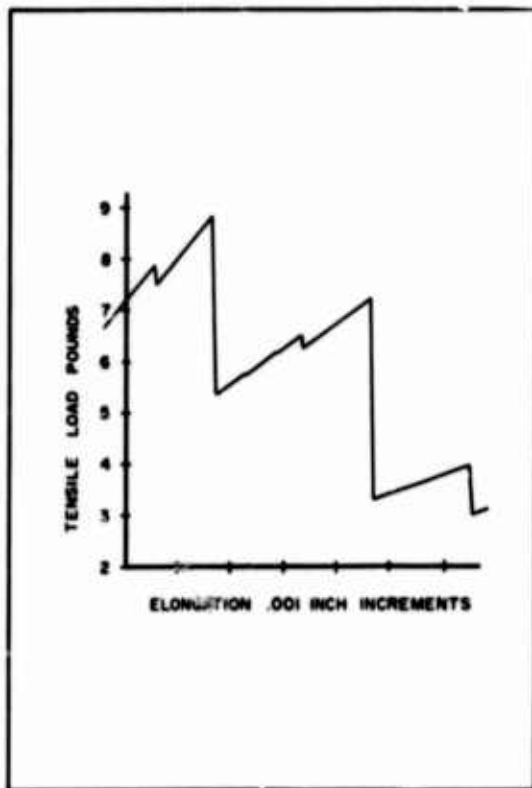

FIGURE 29.
LOAD ELONGATION NO. 105-4

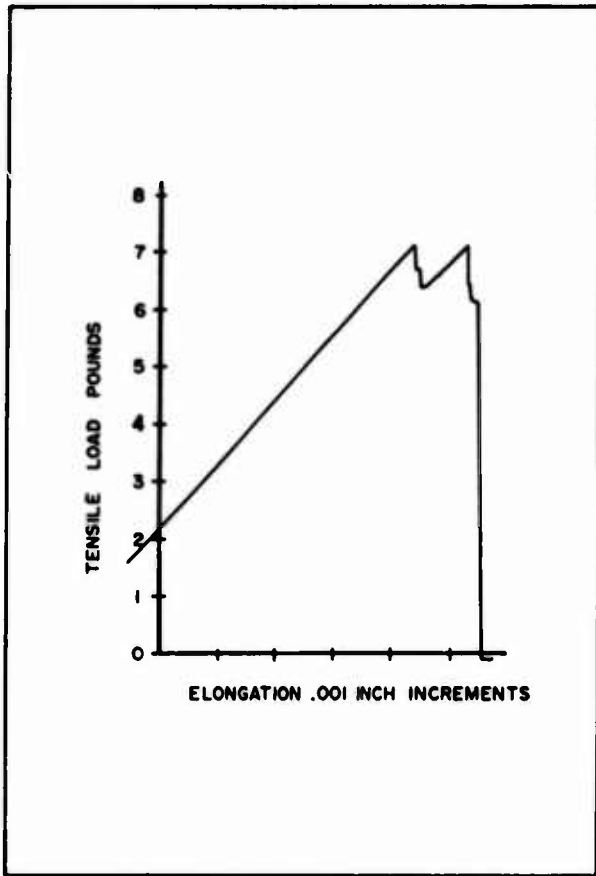

FIGURE 30.
LOAD ELONGATION NO. 291-4



FIGURE 31
TENSILE SPECIMEN
AFTER TEST WITH EDGE DEFECT

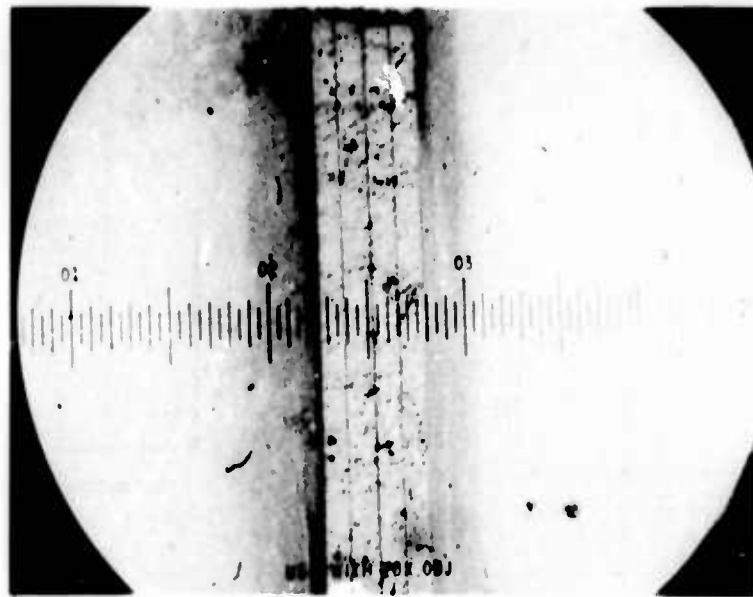

FIGURE 32
EXCELLENT LAMINATE NO. 304-4

ply will fail first. As before, if the remaining plies cannot support the redistributed load, catastrophic failure occurs.

Progressive failure occurs when the plies remaining after the failure of a ply were capable of supporting a significant load. Figure 27 illustrates one case where these discrete ply failures all occur at strains less than the failure strain of the composite, i.e. defined as the strain corresponding to maximum load for this program. The slope of the load-elongation curve decreases after each ply failure, reflecting a decrease in composite modulus. In Figure 28, the initial ply failure corresponds to the maximum load; successive ply failures correspond to decreasing peak loads.

The failure depicted in Figure 29 shows one ply failure before the maximum load is achieved followed by four after this maximum load is reached. If a ply is assumed to support zero load after failure, then the number of ply failures or peaks in the load-elongation curve should be equal to or less than the number of plies. As this curve for a four ply composite exhibits six peaks, it must be assumed that coupling between film and matrix is sufficient for shear stresses in the matrix to reload the fractured film. This may correspond to the peaks of smaller magnitude.

Finally, Figure 30 shows a case where the two peaks are of nearly equal magnitude.

Figure 23 shows a typical fractured composite specimen. Most failures occurred within the gage section. Some were accompanied, however, by longitudinal splitting of the specimen or delamination. Figure 31 shows a fractured specimen where the fracture clearly initiated at an edge flaw.

4.3.3 Composite Quality

The tables in Appendices C and E contain a column for composite quality. This was deduced from external appearance, but mostly from microscopic examination at 400x. In addition to composite quality, composite thickness and total film thickness, from which reinforcement volume fraction was calculated, could be measured. These generally checked composite thickness measured with a micrometer and total film thickness obtained by multiplying the film thickness measured during the graphite film tests by the number of films in the composite.

Composite quality was defined as follows:

1. Excellent (E)—uniform ply spacing, no waviness as shown in Figure 32 .
2. Good (G)
 - a. Uniform spacing, some waviness.
 - b. Some non-uniform spacing, no waviness; Figure 33 .
3. Fair (F)
 - a. One or two plies wavy, non-uniform spacing.
 - b. One or two plies poorly spaced, considerable waviness; Figure 34 .
4. Poor (P)—Gross waviness and/or non-uniformity as shown in Figure 35 .

It should be noted that classification of composite quality is quite subjective. The entries in Appendix D represent agreement by at least two observers.

Using data from Appendices D and E, Figure 36 was drawn showing the relation between composite modulus and strength and composite quality. The quality ratings of excellent, good, fair, and poor were based on Figures 32 to 35 ; the ratings were made by two observers. Most of the composites were rated good; these 'good' composites have efficiencies which encompass the entire range. The excellent composites did not appear to have generally excellent properties; similarly the fair and poor composites did not have uniformly fair and poor properties. However, most of the highest efficiency composites had ratings of good and excellent.

Finally, it should be noted that few voids were found in the composites tested during this program. This is a good indication of the adequacy of the cure cycle and the high quality of the composite specimen fabrication.

4.3.4 Graphite Film Tensile Tests

Analysis of the graphite film tensile data was very similar to analysis of the composite data. The basic data obtained from the load-elongation curves and average film properties are contained in Appendices A and B.

Figure 37 illustrates a number of types of load-elongation curves measured during the course of this program. The majority were linear to failure, typical of brittle materials. Some, however, had a definite yield followed by non-linear behavior to failure. This, however, may have been due to jaw slippage. A few exhibited a concave



NO. 251-T4C



NO. T-13-B

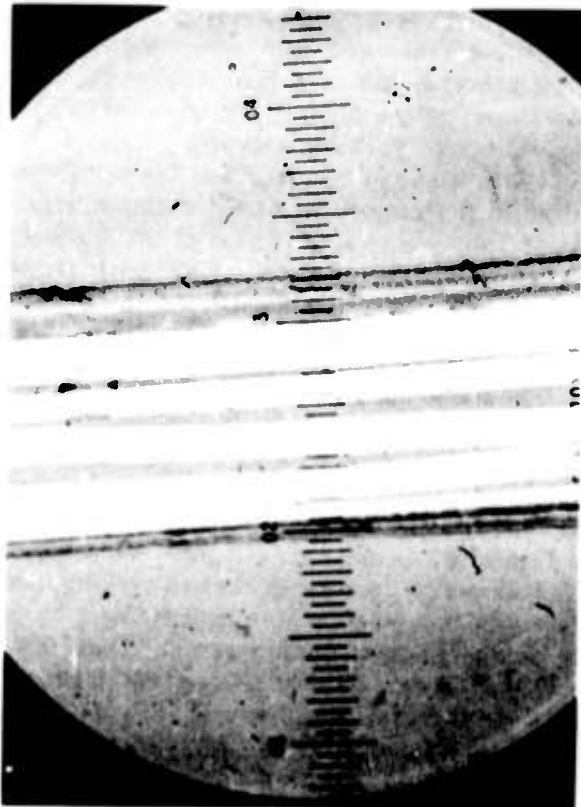

NO. T-8-A

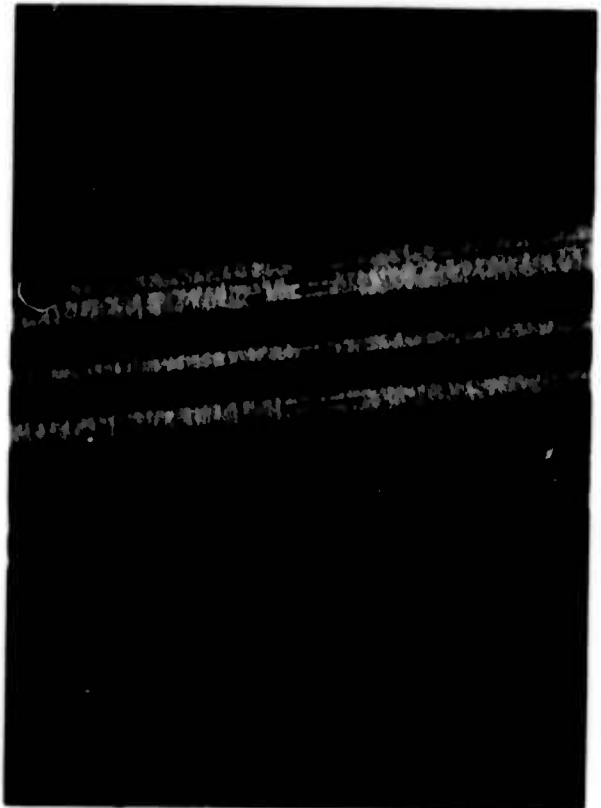

NO. T-14-B

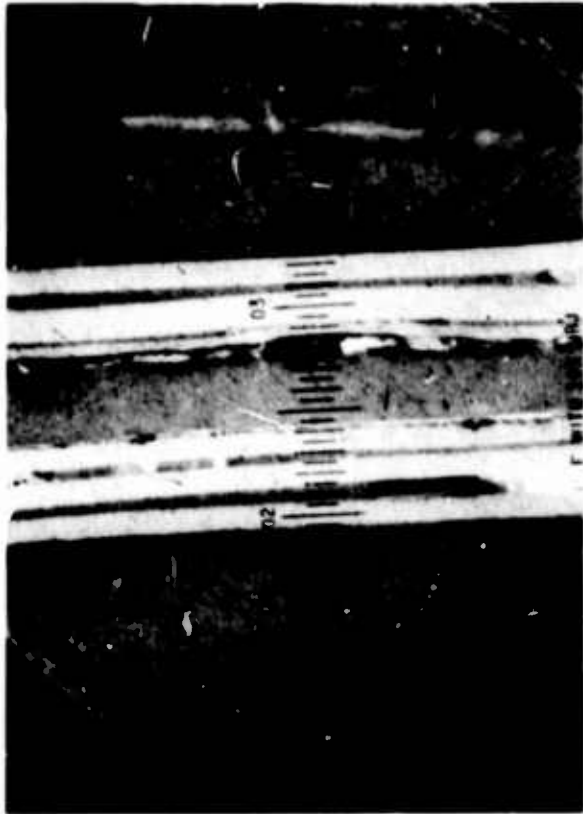

NO. T-6-8

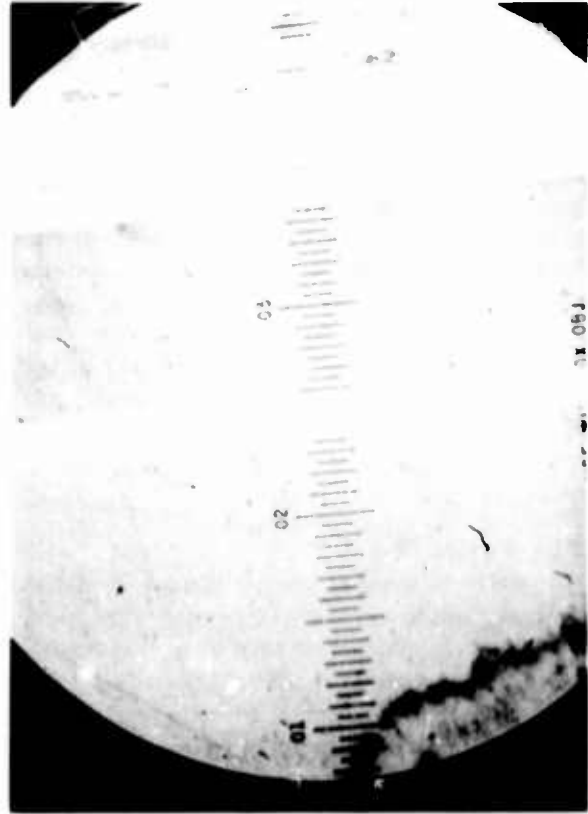

NO. T-11-C

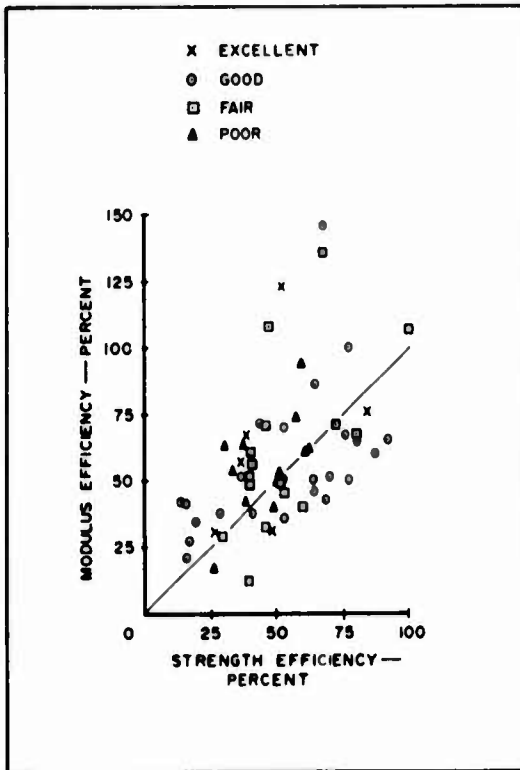

FIGURE 36. EFFECT OF QUALITY ON COMPOSITE PERFORMANCE

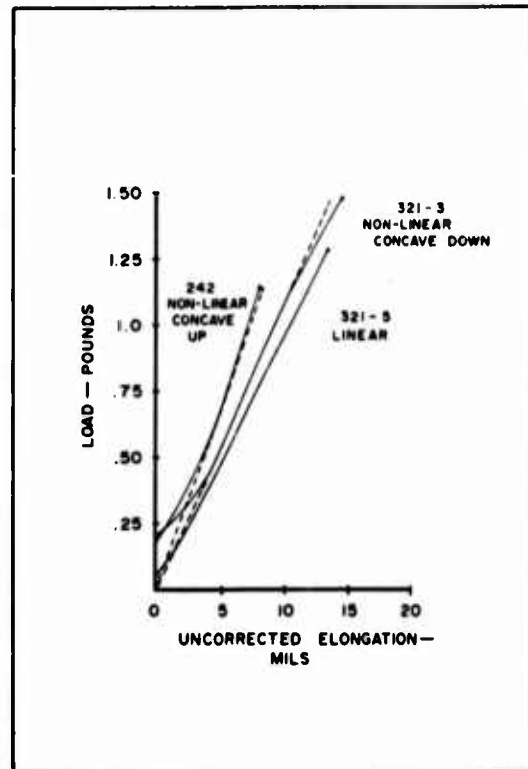

FIGURE 37. LOAD ELONGATION TENSILE CURVES

upward curve over much of the load range; in these cases the modulus recorded corresponds to the maximum slope.

At the lower loads, correction of the elongation, using a calibration curve obtained similar to the composite calibration curve, produced a concave upward rather than a linear curve at low loads as shown in Figure 38. In the case where the inherent film ripples are in the longitudinal direction, this phenomenon may be associated with the tendency for the ripples to straighten. The effect of cross-head speed on film properties for one film was investigated. For each of four speeds, 2 to 3 specimens were tested; the results are shown in Figure 39. Within this range, there appears to be a small effect.

4.3.5 Flexure Tests

To eliminate some of the problems inherent in composite tensile tests, e.g. specimen alignment, tab design, and elongation correction, the applicability of flexure tests to film composite testing was investigated.

To obtain the recommended span to thickness ratio of 15 with a one-inch span would require 150 plies of a 50 volume fraction graphite film composite. As this was considered impractical, the method developed for testing thin filamentary composites was employed. In the filamentary case, a six ply composite is bonded to one side of an aluminum honeycomb core, forming a sandwich structure approximately 22" long, 1" wide, and 1½" thick. If the composite is on the convex side of the beam, tensile properties are measured; if it is on the concave side, compressive properties are measured. As most composites are being applied as skins in sandwich construction, this test seems most appropriate.

In the present case a two to six ply film composite was adhesively bonded to one face of an acrylic beam, 1½" long, 60 mils thick, and ¼" wide. Figure 40 shows a flexure specimen mounted in the Instron testing machine. A cross-head speed of 10-20 mils per minute was used.

4.3.5.1 Data Interpretation

Interpretation of the load-deflection data is not as direct as interpretation of tensile data. Appendix F details the derivation of the equations from which the composite modulus and strength can be deduced. The assumption is made that the

composite thickness f is very small compared to the acrylic beam thickness C . Although a four point flexure test is recommended to minimize the effect of the loading nose on fracture, experience has indicated that, due to asymmetries, failure invariably occurs near a loading nose. Therefore, the analysis and subsequent testing were based on a simple three point flexure test.

Referring to Appendix B and Figure 41, the steps in calculating strength and modulus are:

1. Calculate flexural rigidity from $D = \frac{(\Delta F) I^3}{\Delta 48}$.

For a fixed deflection Δ and span l , D is proportional to the load on the linear portion of the load-deflection curve.

2. Using the acrylic modulus form $\frac{1}{12} E_c b C^3$,

E_c can be found either from a separate test of the acrylic beam or by continuing the flexure test beyond composite failure. The acrylic modulus is proportional to the slope of this curve.

3. Calculate $\beta = D / \frac{1}{12} E_c b C^3$.

4. Determine $a = (\beta - 1) / (4 - \beta)$

5. Finally $E_F = a E_c \frac{C}{f}$

$$\text{and } TS_F = \frac{E_F}{D} \frac{F_{MAX} l}{4} (C + f)$$

It should be noted that the analysis is simplified if a composite is bonded to both sides of the beam. In this case the neutral axis of the beam lies on the geometric centerline, rather than displaced from it.

4.3.5.2 Failure Modes

As in the tensile case, composite failure may either be catastrophic or progressive. The only difference is that the acrylic beam continues to support a load after composite failure. Three failure types are illustrated in Figure 42; the third shows the effect of some delamination prior to failure. In the catastrophic case it was possible to calculate the composite modulus and, therefore, strength from the magnitude of the step in the load-deflection curve. However, these values were smaller than those obtained using the basic method described in section 4.3.5.1.

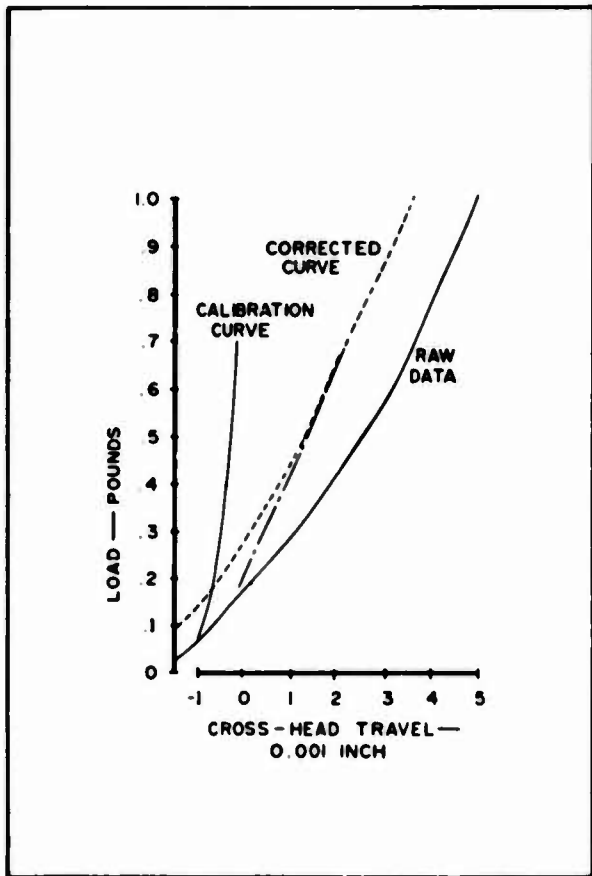

FIGURE 38. CORRECTION FOR CROSS-HEAD TRAVEL

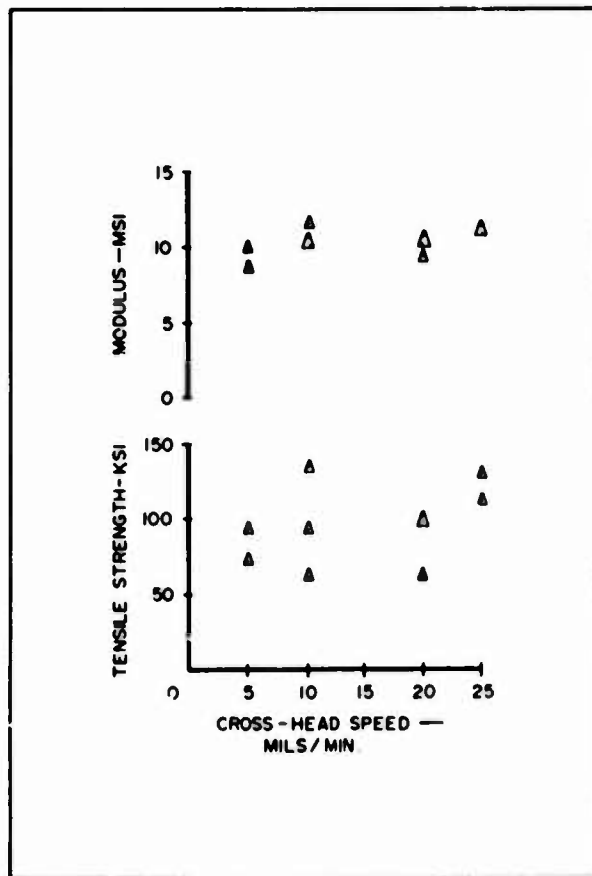

FIGURE 39. EFFECT OF CROSS-HEAD SPEED ON FILM PROPERTIES

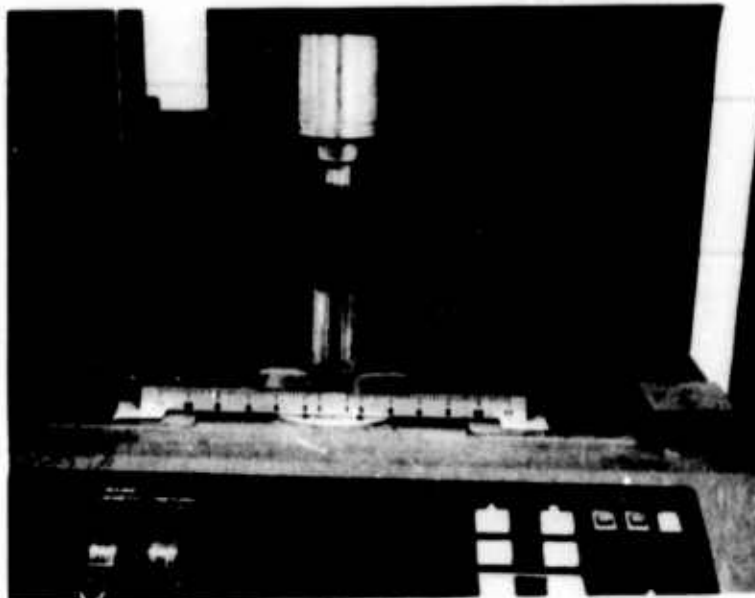

FIGURE 40 FLEXURE TEST SETUP

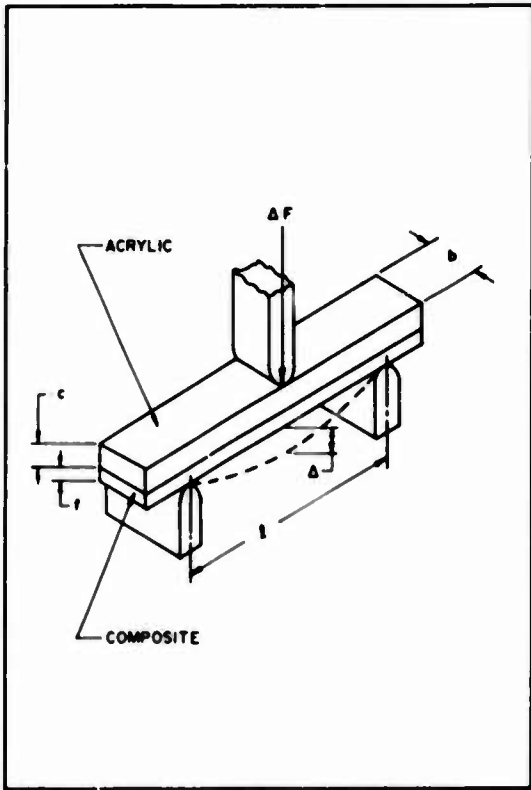

FIGURE 41. FLEXURE TEST FIXTURE

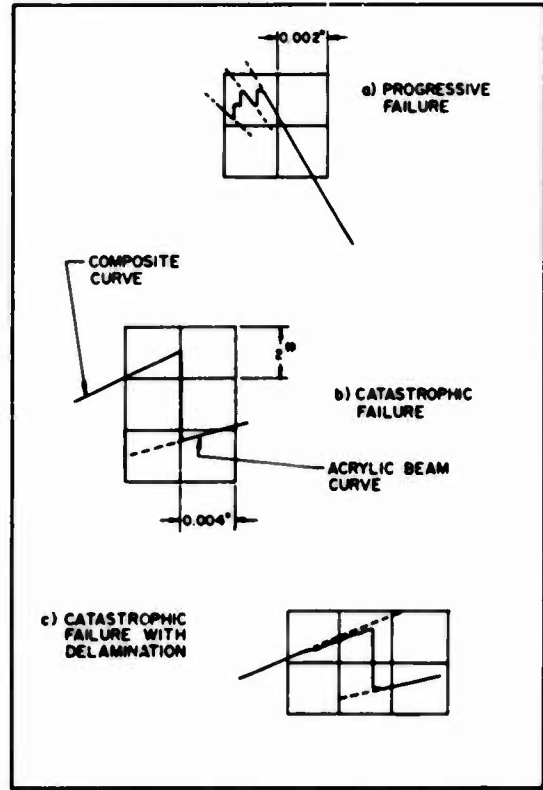

FIGURE 42. FLEXURE FAILURE MODE

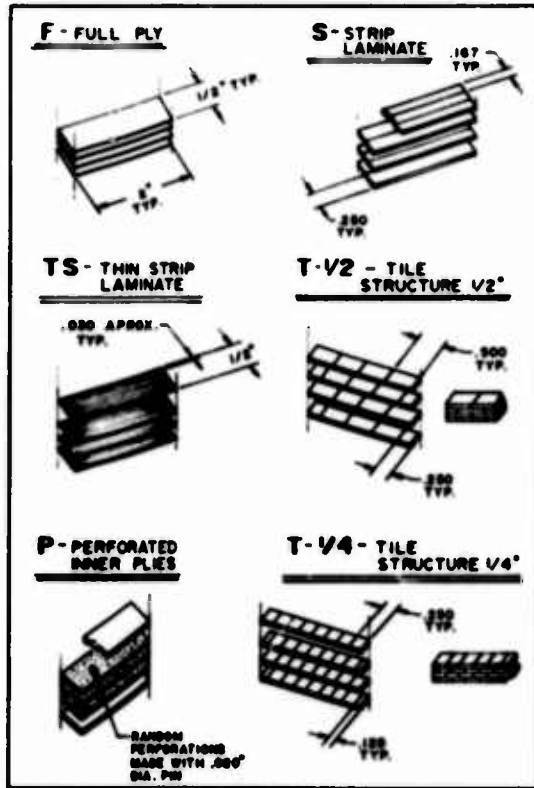

FIGURE 43. TEST LAMINATE STRUCTURES

V. DISCUSSION OF TEST RESULTS

The basic testing procedures used to obtain the mechanical properties of graphite film composites were described in previous sections. In this section, the method of reducing the data and the results based on this data will be discussed.

The measured properties of film type composites depend on the following variables:

1. Film modulus and strength which may depend on:
 - a. film density
 - b. film thickness
 - c. ripples or waves in film
 These are determined by the film processing variables.
2. Matrix characteristics, principally adhesive properties, modulus and strength.
3. Composite structure, e.g. continuous ply, strip, or tile as illustrated in Figure 43.
4. Defects resulting from composite processing, e.g. voids, non-uniform ply distribution, waves or ripples in the transverse direction.
5. Reinforcement volume percent.
6. Number of plies in laminate.
7. Orientation of basic ripples in film relative to load direction.
8. Testing procedure and conditions which include:
 - a. test temperature
 - b. rate of load application
 - c. alignment of test specimen in testing machine jaws
 - d. tab design and adhesive

5.1 Criteria for Composite Evaluation

As a perusal of the basic tensile data shown in Appendix C for the 150 specimens tested indicates, one of the major variables was reinforcement volume percent. At this early stage of development it was not possible to control this variable within close limits. However, its effect can be minimized in the data analysis by considering the effectiveness with which the film properties are transferred into composite properties, i.e. the composite efficiency. The Rule-of-Mixtures states

that the modulus and strength of a composite, either a film type or a filament type parallel to the filaments, can be expressed as,

$$E^1 = X_R E_F + (1-X_R) E_M \quad (5-1)$$

$$S^1 = X_R S_F + (1-X_R) S_M \quad (5-2)$$

Where X is the volume fraction of the composite occupied by the film and the subscripts R and M refer to film and matrix values respectively. If the matrix properties are small compared to the reinforcement properties, they can be neglected.

The composite efficiency is the ratio of the measured value to the rule-of-mixtures value, or

$$\eta(E) = E / E^1 \quad (5-3)$$

$$\eta(S) = S / S^1 \quad (5-4)$$

Note that $\eta(E) \neq \eta(S)$ in general. In cases where the matrix properties are small these equations simplify to,

$$\eta(E) = E / V_F E_F \quad (5-5)$$

$$\eta(S) = S / V_F S_F \quad (5-6)$$

Since $S = F/A$, $E \sim F/A$, and $A_F = V_F A$, the modulus and strength efficiencies depend only on the filament and are independent of the film volume fraction. Thus,

$$\eta(E) = E''/E_F \quad (5-7)$$

$$\eta(S) = S''/S_F \quad (5-8)$$

Where E'' and S'' are based only on the filament area.

In cases where the film properties are below

average, or at low film volume fractions, the general expressions for efficiency should be used. However, this requires knowledge of the matrix properties and how they are affected by acting in combination with the film. For the present analysis, the matrix modulus and strength were included by assuming a matrix modulus of 0.5 MSI and that, at composite failure, the stress in the matrix was 0.5 MSI multiplied by the failure strain. This is equivalent to assuming perfect and linear behavior of the matrix. As noted, the matrix contribution was only significant at low volume fractions and low film properties.

5.2 Graphite Film Tensile Properties

Appendices A and B contain raw and reduced film data for 161 of the films tested during this program. Histograms were constructed for strength and modulus and are shown in Figure 44 along with cumulative distribution curves. The average modulus was 7.1 MSI and average strength was 57.6 KSI. Though not shown, a number of films failed at greater than 150 KSI. The most probable values are less than previously reported (13). This was attributed to the effects of gage length on film properties. In the present tests a one-inch gage length was used; in the previous tests the gage length was $\frac{1}{4}$ ". Due to the effect of edge defects, the $\frac{1}{4}$ " strength, at least, is expected to be greater. To verify this hypothesis, samples of the same film were tested at nominal $\frac{1}{4}$ ", $\frac{1}{2}$ ", $\frac{3}{4}$ ", and 1" gage lengths.

The results are shown in Figure 45. Considerable scatter exists attesting to the difficulty of mechanically testing thin films. However, the average curve through these points shows a drop in both modulus and strength with increasing gage length between $\frac{1}{2}$ " and 1". Curiously, the modulus and strength appear to increase between $\frac{1}{4}$ " and $\frac{1}{2}$ "; more data with different films would be required to establish the existence of an optimum gage length.

Figure 46 and Table 2 show the effect of film thickness on modulus and strength. Except for the 0.1 mil value, the modulus appears to be independent of film thickness over the 0.1 to 0.3 mil range. The strength does, however, appear to decrease with increasing film thickness; this is masked to a great extent by scatter due to edge defects and testing technique.

Finally, Figure 47 shows the effects of specific gravity on modulus and strength for 0.2 mil films. Note that over 1/3 of the films tested were 0.2 mil thick. From the plot, it can be inferred that specific gravity does not have a strong influence on graphite film properties.

TABLE 2

Film Properties as a Function of Film Thickness

Thk. -Mils	# Samples	SG Avg.	TS-KSI	E-MSI
.14	2	6.00	60.9	6.00
.18	4	1.79	42.2	6.76
.20	62	1.69	56.8	7.72
.21	5	1.58	84.0	7.05
.22	8	1.29	41.3	7.02
.23	3	1.94	46.2	7.23
.24	7	1.73	61.4	6.43
.25	19	1.79	44.3	6.53
.26	6	1.76	53.0	6.64
.27	5	1.87	63.2	6.44
.29	2	1.61	35.1	3.67
.30	8	1.59	37.2	6.37
.31	9	1.68	51.6	5.08
.32	5	1.81	69.1	5.89
.34	3	2.19	16.6	3.51
.38	5	1.51	46.9	5.61
.41	2	1.19	45.3	3.04

5.3 Composite Tensile Properties

Raw and reduced data for all specimens tested in this program are contained in Appendices C to E. For purposes of calculating composite efficiency using equations 5 - 3 and 5 - 4, the following graphite film data bases were used:

1. Measured tensile modulus and strength when available for the specific films used for a composite specimen.
2. Film modulus and strength deduced from single ply test data assuming 100% efficiency.
3. The average film modulus and strength based on all films tested. These were 7.1 MSI and 57.6 KSI respectively for a sample size of 161.

The variables investigated include reinforcement volume fraction, matrix film isotropy, number of plies, and composite structure.

5.3.1 Volume Fraction

Table 3 and Figures 48 to 49 give modulus

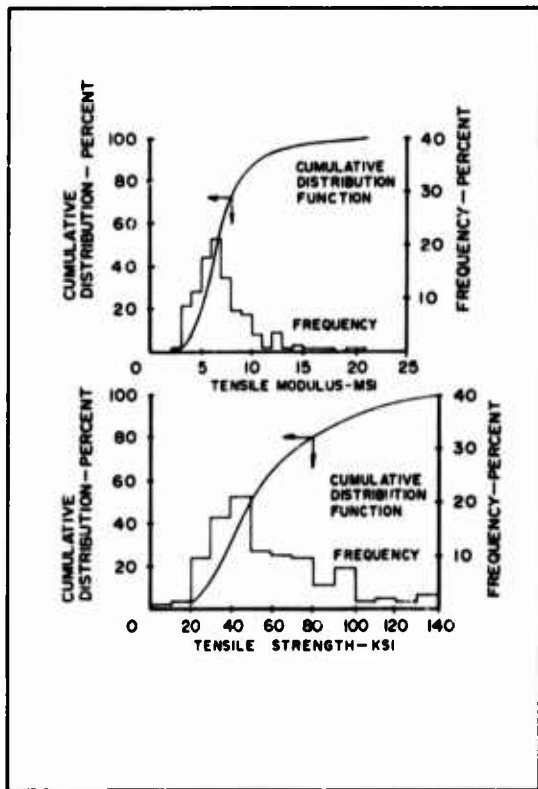

FIGURE 44. DISTRIBUTION OF MODULUS AND STRENGTH OF GRAPHITE FILM

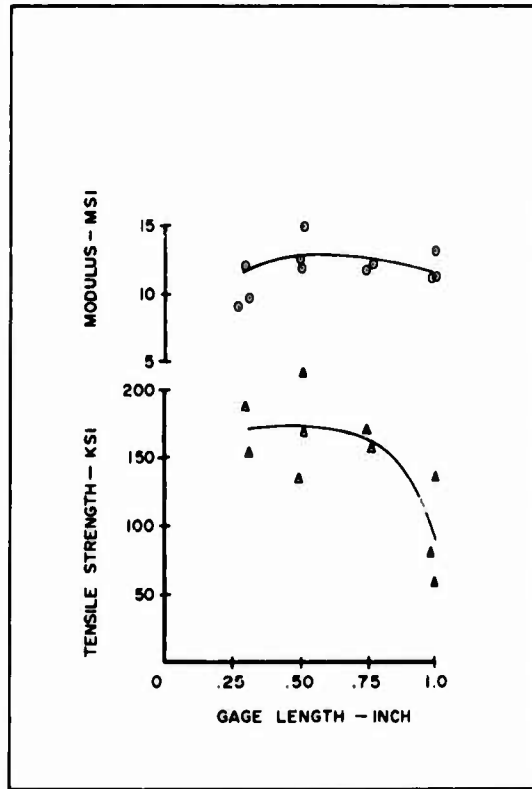

FIGURE 45. EFFECT OF GAGE LENGTH ON FILM PROPERTIES

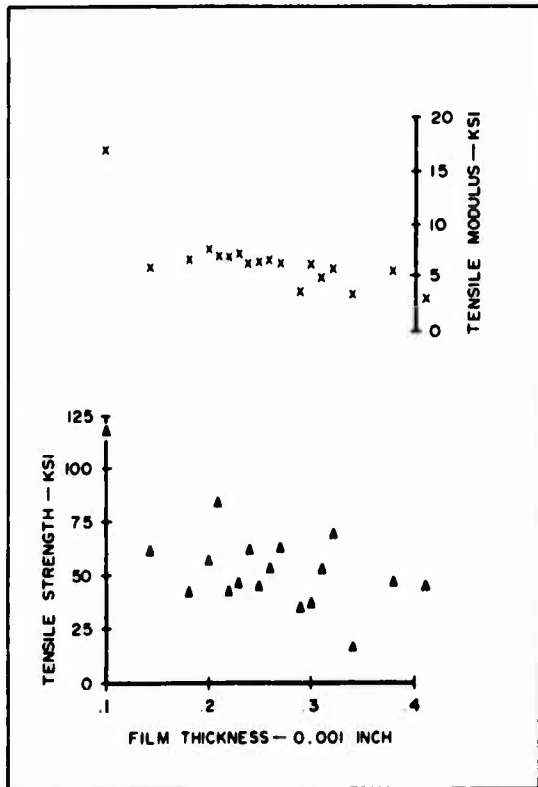

FIGURE 46. EFFECT OF FILM THICKNESS ON STRENGTH & MODULUS

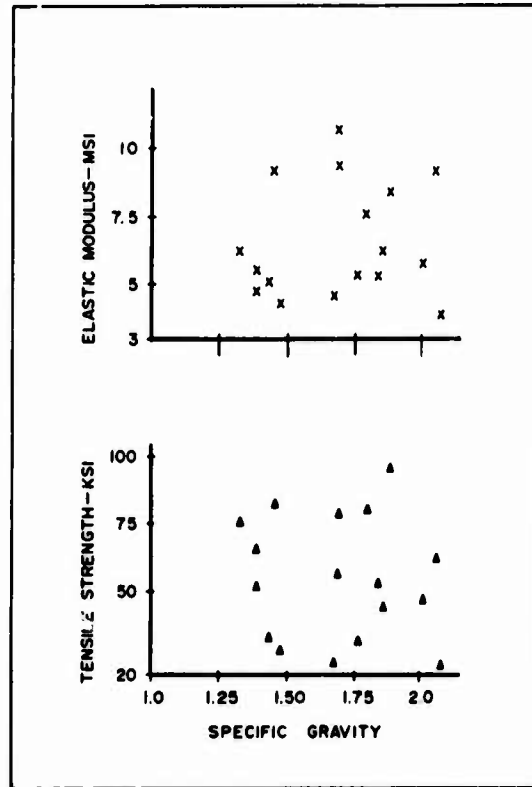

FIGURE 47. EFFECT OF SPECIFIC GRAVITY ON FILM PROPERTIES

and strength efficiency data as functions of reinforcement volume fraction. This data is limited to laminates with greater than four plies and to those for which graphite film data is available. The data was divided into two groups: those for which the film modulus or strength were below average and those for which the reverse is true.

Within the 15 to 75% reinforcement volume range, there appears to be no pronounced effect of reinforcement volume fraction on efficiency. However, it should be noted that the highest strength efficiency at any volume fraction decreased with increasing volume fraction. The average of all values is 0.527 based on modulus and 0.537 based on strength; values above 0.50 are considered excellent at this early stage of graphite film composite development.

TABLE 3
Basic Multi-Ply Laminate Efficiency Data

Sample	Less Than Average Properties	No. Plies	XR	$\eta(E)$	$\eta(TS)$	Fail. Mode
13-4		4	.147	31.6	45.5	C
13-6		6	.591	29.9	47.1	P*
20-4		4	.258	30.9	68.5	C
20-4A		4	.160	32.6	33.6	C
97-8	X	8	.591	70.8	33.4	P*
102-4A	X	4	.187	84.3	85.4	P
102-6	X	6	.255	85.8	81.0	C
111-4L		4	.444	56.7	36.1	C
124-4		4	.367	40.6	76.0	P*
179-4L		4	.500	18.4	14.7	P*
205-6		6	.444	31.9	58.1	P*
242-4	X	4	.256	89.9	74.5	P*
248-6		6	.512	42.7	68.1	P*
248-6A		6	.667	34.9	57.0	C
249-4		4	.235	29.5	40.8	C
249-4A		4	.714	29.7	48.5	C
269-4		4	.250	65.2	60.8	P*
278-4	X	4	.476	83.1	66.1	P
279-4	X	4	.600	89.2	49.3	P*
291-4	X	4	.571	66.1	42.5	C
297-4	X	4	.522	28.7	23.4	C
297-4A	X	4	.500	53.6	51.7	C
304-4		4	.524	30.9	47.8	C
318-4	X	4	.348	79.9	69.4	P*
318-6	X	6	.429	80.7	62.9	P*

*Film fracture prior to reaching peak load.

One important aspect is the relationship between film properties and the properties of com-

posites made from these films. This involves the effects of the matrix on cracks propagating from edge defects in the film and in restraining the film during tensile loading. Perusal of the data indicates that the highest modulus efficiency values were obtained with below average film modulus. However, over the range of modulus efficiencies the poorer film properties resulted in lower strength efficiencies. Perhaps the only conclusion that can be reached, at this time, is that films with poor properties do not necessarily produce composites with correspondingly poor properties. This may also explain the greater than 100% efficiencies obtained in some cases, e.g. composites made from film number 291.

This result is demonstrated further in Figure 50 in which modulus efficiency is plotted against strength efficiency and the line drawn in the figure represents equal efficiencies.

5.3.2 Matrix

Matrices investigated in this program were:

- A. CIBA Araldite 6004 Epoxy + 20PHR Shell Catalyst Z
- B. 50% by weight CIBA Araldite 6004 Epoxy Resin + 50% General Mills Versamide 140
- C. CIBA Araldite 6004 + 70PHR Hexahydrophthalic Anhydride + 2PHR Aragus DB-VIII
- D. Union Carbide ERLA 4617 Epoxy Resin + 25PHR m-Phenylene + diamine + 1.5PHR BF₃ · Monoethylamine
- E. DuPont Adiprene 315 Urethane Resin + 26PHR Moca Catalyst

The letter designations correspond to those in Appendices C and D. Table 4 compares matrices A and C for graphite film 316. On the basis of the composite property data, plus handling and composite fabrication considerations, Matrix A is considered the best of the matrices investigated in this program. Most of the higher absolute values were obtained by use of Matrix A.

5.3.3 Film Isotropy

Due to the film fabrication process, well defined ripples appear in the film. For purposes of identification, the 0° or L direction refers to ripples in the longitudinal specimen direction, whereas 90° or C refers to ripples in the transverse specimen direction. Table 5 gives efficiency data for 4 to 6

ply laminates for which the same film was oriented in the 0° and in the 90° directions. Figures 51 and 52 show the 90° modulus and strength values plotted against the corresponding 0° values; where duplicate tests of the same combination exist, average values were used. The strength efficiencies of 90° composites appears higher than those of 0° composites. This may be due to fewer edge defects arising from cutting 90° film compared to 0° film.

Figure 53 shows all data as functions of reinforcement volume fraction; the peak values at any fraction are generally greater for 90° than for 0° with the difference more apparent in strength than modulus.

As Figures 51 and 52 only contain four data points, the basic conclusion may be modified when the data base is expanded.

TABLE 4

Effect of Matrix on Composite Properties

Sample	Matrix	XR	$\eta(E)$	$\eta(TS)$
316-4	A	.148	66.9	75.7
316-4A	C	.111	74.2	92.9
316-6	A	.906	50.4	63.3
316-6A	C	.400	93.7	124.0

TABLE 5

Effect of Film Isotropy on Composite Properties

Sample	Direction	XR	$\eta(E)$	$\eta(TS)$
111-4L	0	.444	56.7	36.1
111-4C	90	.556	48.0	39.6
178-6L	0	.323	62.5	29.3
178-4C	90	.438	55.6	40.7
266-5AL	0	.571	49.9	51.4
266-5C	90	.542	65.5	91.7
266-4C	90	.391	76.1	84.1
322-T4L	0	.173	29.7	29.5
322-T4L'	0	.225	59.3	39.5
322-T4C	90	.244	60.4	40.9
322-T4C'	90	.242	65.7	60.5

5.3.4 Number of Plies

One assumption in tensile testing is that the tab/tab adhesive design and composite matrix act to uniformly distribute the applied load over the plies. To verify that this indeed was the case, a

number of composites having one to six plies were tested. Table 6 and Figures 54 and 55 give the basic results. The points in the figures were connected by straight line segments, only to assist in tracing the effects of number of plies on composites made from the same film. Based on this data, no general trend can be established. It can thus be assumed, subject to further testing, efficient composites can be made with any number of plies.

5.3.5 Composite Structure

During the course of this program four composite specimen structures were investigated—continuous or full film (F) per ply, strip(s), and tile or brick (T). These are illustrated in Figure 56. The basic premise in strip and tile construction is that discontinuities in the film may act to arrest cracks propagating from edge defects in the film.

TABLE 6

Effect of Number of Plies on Composite Properties

Sample	No. Plies	XR	$\eta(E)$	$\eta(TS)$
242-1	1	.150	33.2	22.0
242-1A	1	.250	77.2	61.9
242-2	2	.239	164.0	15.9
242-3	3	.400	92.0	51.0
242-4	4	.256	89.9	74.5
253-1	1	.094	100.0	100.0
253-2	2	.100	73.5	70.9
253-2A	2	.125	78.9	68.1
253-4	4	.294	207.0	205.0
253-4A	4	.262	110.0	142.0
269-1	1	.150	56.4	39.7
269-1A	1	.117	49.6	18.1
269-2	2	.238	50.2	57.7
269-3	3	.181	46.6	56.7
269-4	4	.250	65.2	60.8
291-1	1	.154	30.1	65.8
291-2	2	.308	12.4	70.4
291-2A	2	.308	16.4	19.3
291-4	4	.571	66.1	42.5
296-1	1	.750	100.0	100.0
296-2	2	.763	92.3	82.4
296-6	6	.600	86.4	84.8
318-3	3	.750	96.2	64.4
318-4	4	.348	79.9	69.4
318-6	6	.429	80.7	62.9

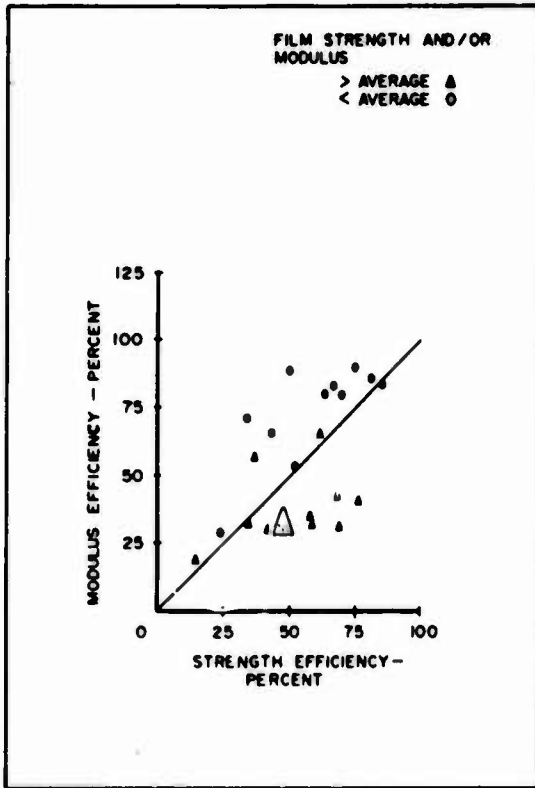

FIGURE 50. RELATIONSHIP BETWEEN MODULUS AND STRENGTH EFFICIENCIES

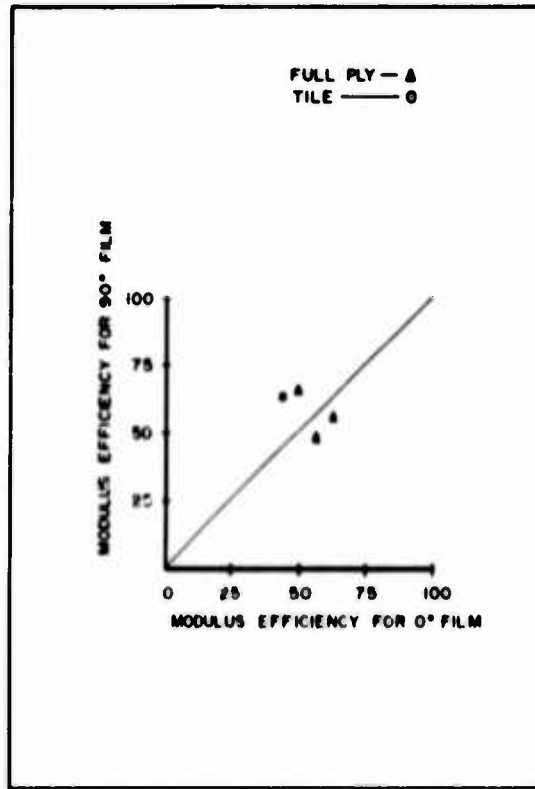

FIGURE 51. EFFECT OF FILM ISOTROPY ON MODULUS EFFICIENCY

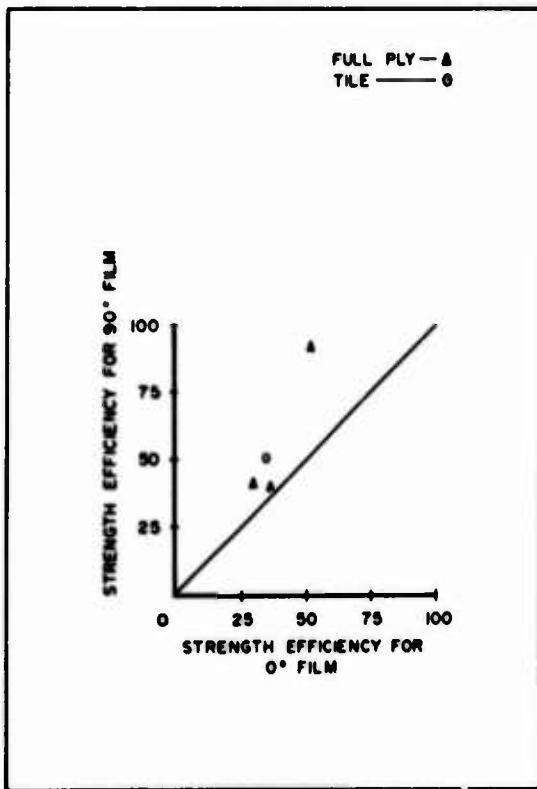

FIGURE 52. EFFECT OF FILM ISOTROPY ON STRENGTH EFFICIENCY

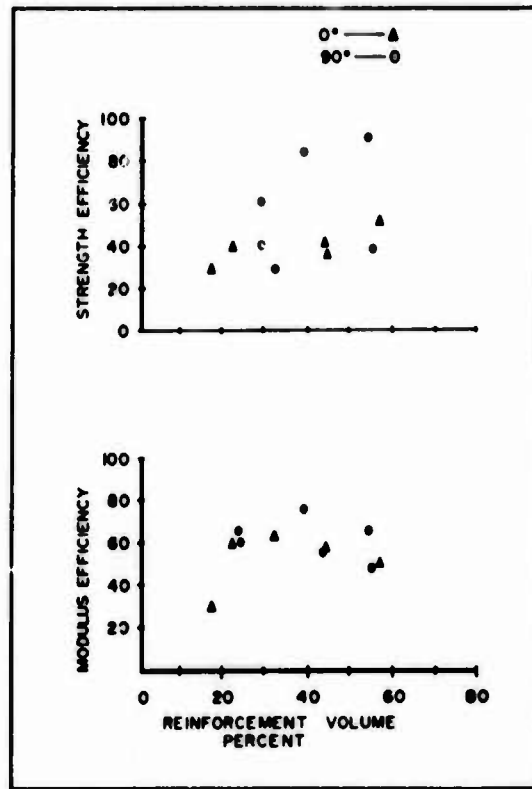

FIGURE 53. EFFECT OF FILM ISOTROPY ON COMPOSITE PROPERTIES

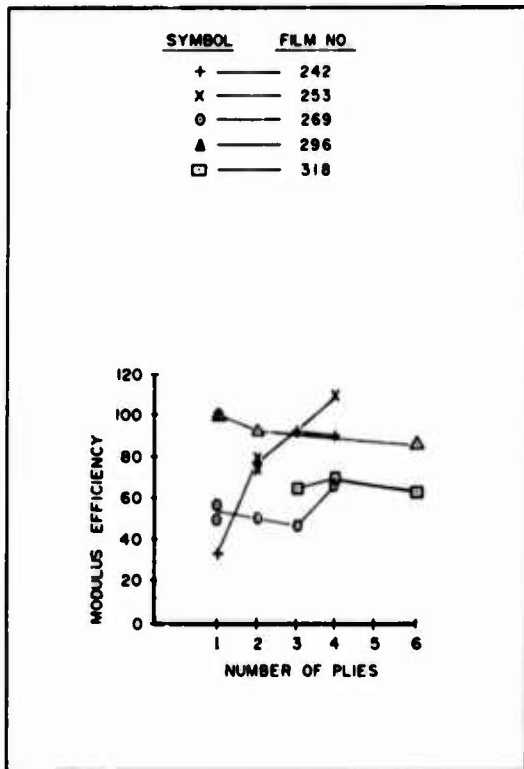

FIGURE 54. EFFECT OF NUMBER OF PLYS ON MODULUS EFFICIENCY

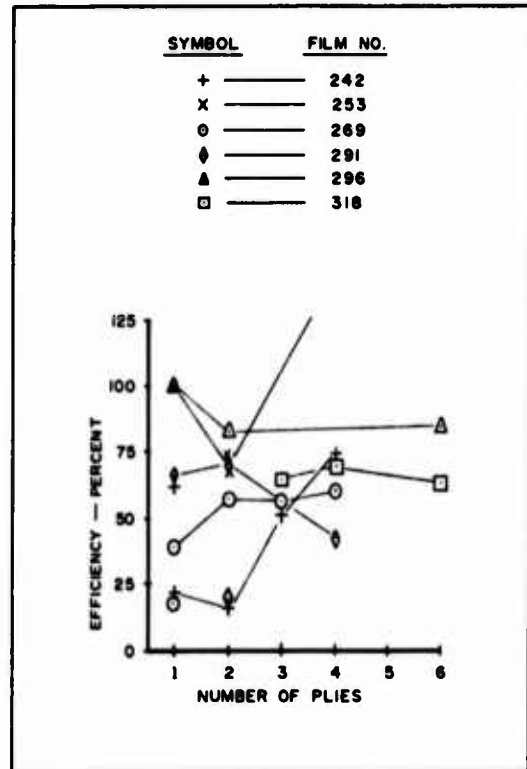

FIGURE 55. EFFECT OF NUMBER OF PLYS ON STRENGTH EFFICIENCY

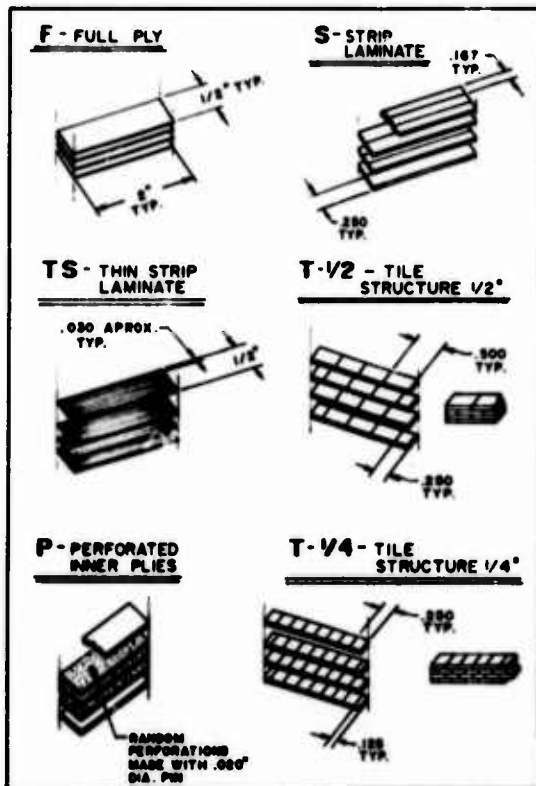

FIGURE 56. TEST LAMINATE STRUCTURES

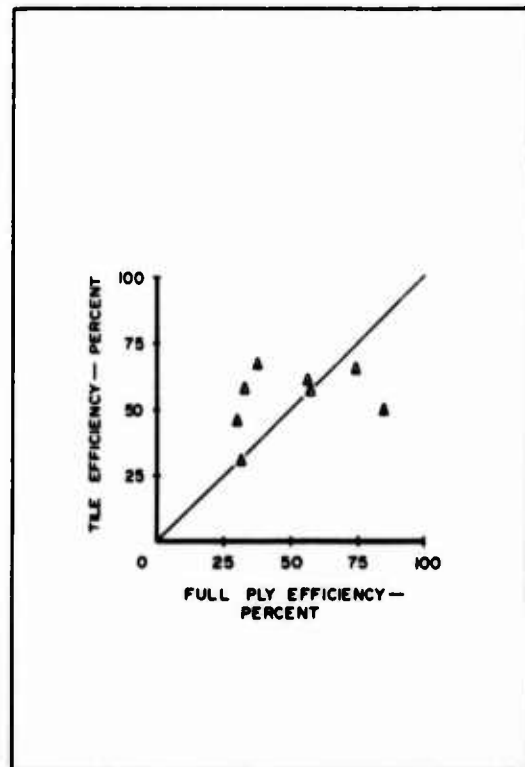

FIGURE 57. EFFECT OF STRUCTURE ON COMPOSITE MODULUS EFFICIENCY

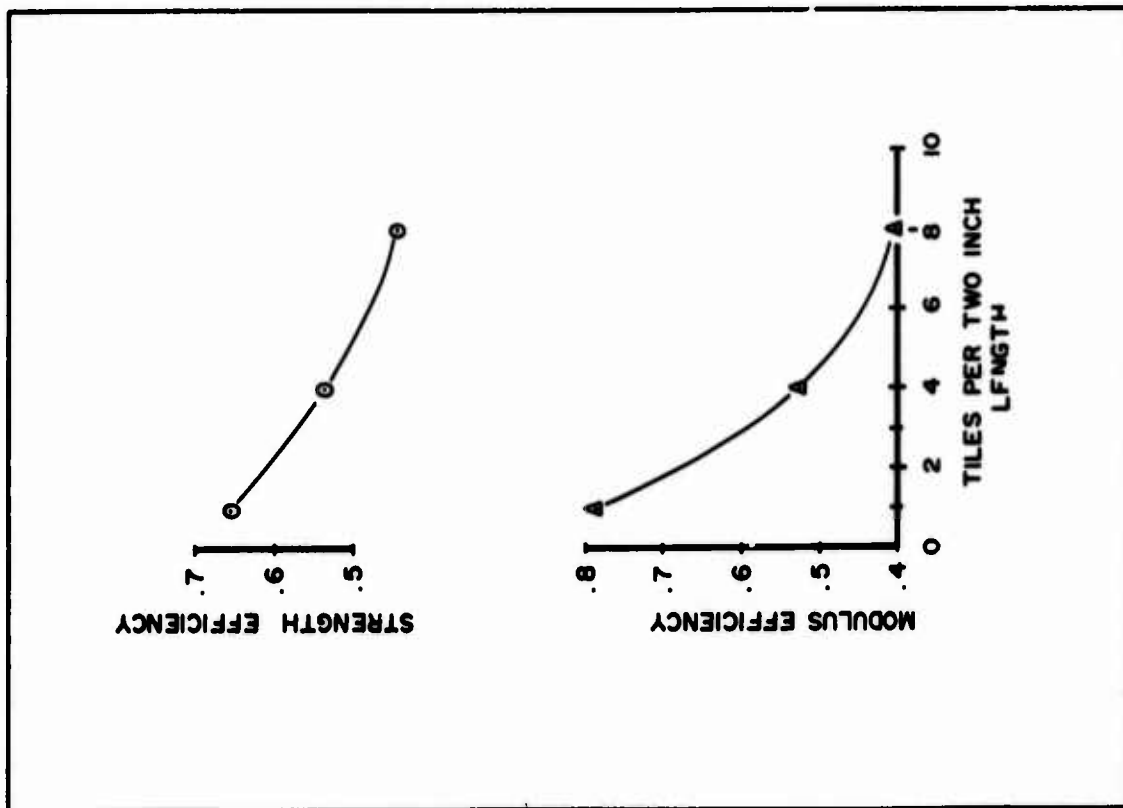

FIGURE 59. EFFECT OF TILE SPACING ON COMPOSITE EFFICIENCY

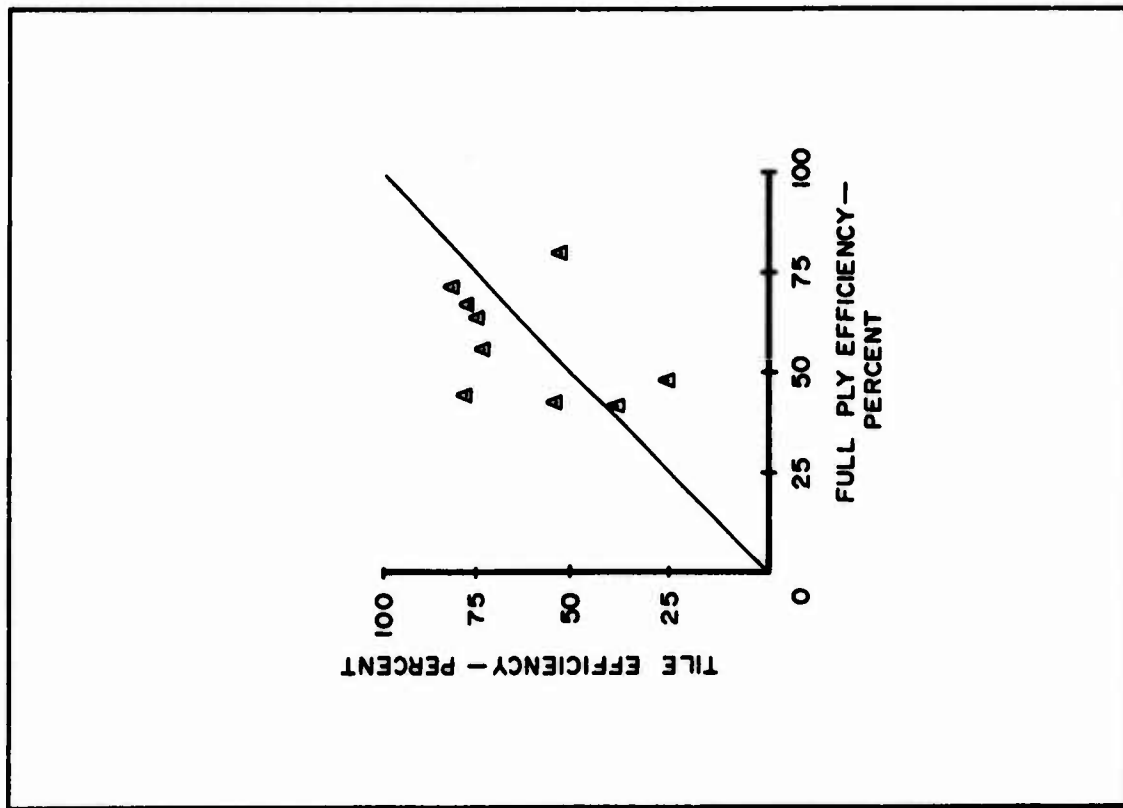

FIGURE 58. EFFECT OF STRUCTURE ON COMPOSITE STRENGTH EFFICIENCY

The results are given in Table 7 and Figures 57 and 58. In these figures the tile efficiency is plotted against the full ply efficiency. From this limited data it would appear that the more difficult tile structure is superior. This may be a result of fewer defects in shorter film lengths as illustrated in Figure 45, as well as the effects of discontinuities or crack propagation. However, when all comparable tile and full ply data are considered, the superiority of the tile structure is less apparent. From this fact and the considerations discussed in Sec. 2.0 as well as the relative ease of preparing full ply composites, it was concluded that the full ply structure would be preferred for most applications.

TABLE 7

Effect of Structure on Composite Properties

Sample	Structure	XR	$\eta(E)$	$\eta(TS)$
105-4*	F	.300	84.3	52.7
105-4A	T	.533	85.8	89.8
105-4B	T	.429	49.4	81.4
246-4C*	F	.170	37.5	41.4
246-T6C	T	.278	67.1	38.7
249-4	F	.235	29.5	40.8
249-4A	F	.714	29.7	48.5
249-4B	T	.258	45.9	77.3
251-3C*	F	.167	61.4	61.5
251-3C ¹	F	.110	52.3	51.6
251-T4C	T	.288	64.4	86.7
251-T4C ¹	T	.325	49.8	59.3
291-4	F	.571	66.1	42.5
291-4B	T	.229	225.0	53.4
293-3C*	F	.318	74.1	80.3
293-T3C	T	.267	49.4	37.9
293-T3C ¹	T	.308	80.6	66.5
304-4	F	.524	30.9	47.8
304-4T	T	.500	30.4	25.8
304-6T	T	.394	32.6	45.8
307-4C*	F	.237	56.2	64.1
307-T4C	T	.281	60.9	74.4
308-4*	F	.196	32.2	67.1
308-4B	T	.354	58.2	77.3

*Data based on averages

Figure 59 was constructed to demonstrate possible effects of tile length on composite performance. The abscissa represents the number of tiles per 2-inch length. There appears to be little difference between $\frac{1}{2}$ " and $\frac{1}{4}$ " tiles. Also shown is the average strip laminate data obtained early in

the program. The two thin strip composite specimens tested showed poorer average efficiencies than the strip specimen average. This is probably due to the difficulty of fabricating these specimens, and resultant damage to the film during the composite fabrication.

Finally the specimens made from film 53 had film perforations in the middle plies to improve load transfer; the efficiencies did not differ from those without perforations, however, and this approach was not pursued further.

5.4 Composite Flexure Properties

Three-point flexure tests were performed on a number of specimens; the method described in Section 4.3.4 analyzes the data. Appendices G and H give the basic data which is summarized in Table 8. Table 8 also gives equivalent tensile data. In the three cases where comparison was possible, the flexure efficiencies were significantly higher than the tensile efficiencies. More tests are required before conclusions can be made as to the adequacy of this alternate to tensile testing.

5.5 Assessment of Test Results

In Sections 5.3 and 5.4 the results of 150 tensile tests and six flexure tests were used to study the effects of many of the variables listed in Section 5.1 on the modulus and strength of single graphite film and film composites. The purpose of this section is to comment on these test results.

5.5.1 Reproducibility of Test Data

At the onset, it must be recognized that tensile testing of very thin composite specimens is a difficult procedure. One major problem is alignment of the specimen in the test jaws. In the film tests this was accomplished by initially mounting the film in a frame and then carefully cutting the vertical members of the frame. In the case of composite specimens, alignment was principally visual. Any residual bending or twisting movements tend to reduce the apparent film or composite tensile strength. A second problem concerns measurement of specimen elongation. Because of the small specimen size, strain gages and conventional extensometers cannot be used. Instead cross-head travel experimentally corrected for tab/specimen adhesive bond line slippage

TABLE 8
Tensile/Flexural Data Comparison

Flex. No.	XR-%	(E)	(TS)	Tens. No.	XR-%	η (E)	η (TS)
T5	0.900	31.7	33.8	T5A	0.690	26.3	35.8
T5D	0.857	83.6	68.9				
T6	0.650	123.0	103.0	T6B	0.500	73.3	56.9
T8B	0.571	90.9	99.7				
T8D	0.571	126.0	77.0				
T10	0.400	113.0	120.0	T10	0.400	86.0	63.9

and/or jaw slippage, was used. This affects only the calculated modulus and not the strength of the specimen.

Alignment and elongation correction effects can be assessed by repeating tests of similar specimens. Table 9 compares similar data for a few graphite film specimens, whereas Table 10 compares tensile data for film composites. Differences are attributable to film thickness variations within a single film from which the specimens were cut; errors in physical measurements as discussed below; the sensitivity of strength to specimen edge defects; and to composite quality, e.g. film ripples and non-uniform spacing. Due to edge defects, scatter in strength measurements is generally greater than scatter in modulus measurements. As an example, an edge defect was noted in the case of tile specimen 297-4 which accounts for the difference in strength efficiency compared with 297-4A; the modulus efficiency difference, however, remains unexplained.

TABLE 9
Reproducibility of Graphite Film Data

Specimen	E (MSI)	TS (KSI)
20	9.81	78.6
	8.37	62.3
248	10.20	84.5
	10.70	89.4
297	6.52	63.4
	6.12	72.3
	6.40	81.9

5.5.2 Suitability of Evaluation Criteria

Composite efficiency, defined by equations (5-3) and (5-4) was chosen to represent composite performance because of their relative insensitivity to measurements of film and composite thickness within the reinforcement volume range

TABLE 10
Reproducibility of Composite Data

Specimen	η (E)	η (TS)
20-4	30.9	68.5
20-4A	32.6	33.6
248-6	42.7	68.1
248-6A	34.9	57.0
249-4	29.5	40.8
249-4A	29.7	48.5
297-4	28.7	23.4
297-4A	53.6	51.7

of interest, i.e. greater than 50%. Considering modulus efficiency, the following relation applies wherein lower case symbols refer to the film, upper case to the composite and N is the number of plies.

$$\eta(E) = \frac{\Delta F}{\Delta L} \frac{L_0}{WT} \sqrt{\frac{0.5 + (\Delta f l_0 \cdot 0.5)}{\Delta l wt}} \frac{Nt}{T}$$

As Nt approaches T at large reinforcement volumes, the matrix modulus becomes negligible and (E) reduces to,

$$\eta(E) = \frac{1}{N} \frac{\Delta F / \Delta L}{\Delta f / \Delta l} \frac{L_0}{l_0} \frac{w}{W} \frac{(t)}{Nt}$$

which shows, at least to a first approximation, that $\eta(E)$ is independent of composite thickness T, and film thickness t if the total film thickness is taken as the number of plies multiplied by t. Similar reasoning applies to strength efficiency. In cases where Nt is much less than T at low reinforcement volumes; when average film rather than specific film properties are used; or when the product Nt is measured; η becomes dependent on t and on T.

The thickness of a single film and of multiple films in a composite were measured from photo-

micrographs at 400x to 600x magnification. The smallest division on the reticle scale is 0.0001 inch; assuming a measurement to be within $\frac{1}{2}$ this amount, the possible maximum error is 25% for a 0.0002 inch thick film. As Nt is measured using the same reticle scale, the error in the average t may thus only be 5%, for $N = 5$. Therefore, η is affected directly by the accuracy in measuring t for a single film compared to Nt for the composite. As noted above, if the total film thickness is assumed to be Nt this error disappears. In addition to its effect on η , errors in measuring t affect absolute values of film strength and modulus; a 25% error in t produces 25% errors in both parameters.

For all the specimens tested, composite thickness was measured using a micrometer; this value was used to calculate composite modulus, strength, and reinforcement volume for the specimens tested. Toward the end of the program it was realized that this measurement included coatings that were applied to specimens to facilitate handling and minimize surface damage.

Examination of photomicrographs corresponding to these specimens showed that the actual reinforcement volume was greater than that deduced from the micrometer measurement. The net effect is to increase the composite modulus and strength and leave efficiency relatively unchanged. This is illustrated in Table 11 for Specimen 111-4C. Although the strength and modulus increased inversely with composite thickness, both moduli remained nearly the same.

TABLE 11
Effect of Composite Thickness Measurement
on Properties
Specimen 111-4C

Composite Thickness, Mils	1.20	1.80
Total Film Thickness, Mils	1.00	1.20
XR - %	83.30	55.60
Modulus - MSI	3.84	2.56
Strength - KSI	26.70	17.80
ROM - E	7.74	5.33
ROM - S	69.70	47.70
η (E)	49.60	48.00
η (TS)	38.30	39.60

Finally it should be remarked that the Rule-of-Mixture estimate of composite strength and effi-

ciency assumes that the properties of the matrix and film in the composite are the same as those measured separately. As a result of the difference in film support during test, (i.e. at the end during film test and along its length, by the matrix, during composite testing) the effective ROM value may be different than that calculated.

5.5.3 Comments on Results

In the course of this program, the effects of film properties, matrix, reinforcement volume, film isotropy, structure, and number of plies on the modulus, strength, and efficiency of graphite film/epoxy composites were investigated. The results, in terms of composite efficiency based on modulus and strength, indicated that:

1. Properties were somewhat greater in the C or 90° film direction compared with the L or 0° direction. This may be due to edge defects which reduce strength, and as indicated previously, the cut edge of the L direction is likely to have more edge defects.
2. Tile structured composites appeared superior to continuous film composites probably due to the effect of discontinuities on the propagation of cracks from edge defects. However, data showing the effect of tile length on performance indicated the superiority of strip and continuous film composites. From the viewpoint of isotropy and ease of fabrication, either strip composites with alternating 0° and 90° plies or continuous films are recommended.
3. Number of plies and reinforcement volume appeared to have little effect on modulus and strength efficiencies. Both average efficiencies were greater than 50% with more scatter in the strength than in the modulus values.
4. Average film strength and modulus were less than measured in a previous study (13) probably due in the case of strength to use of a 1-inch rather than a $\frac{1}{4}$ -inch gage length. The modulus difference may be due to quality control of the small batches of film produced for this program. This may also be attributable to the fact that stress levels attained in the 1.0 inch gage length were not high enough to display the true modulus of the material.
5. The few flexural specimens tested gave higher modulus and strength values than those meas-

ured in tensile tests of nearly identical specimens. Further study of this test method is required.

6. Composites made with films with less than average properties appeared to give at least as high modulus and strength efficiencies compared with composites made with films of

above average properties. The maximum composite modulus and strength measured were about 6 MSI and 60 KSI for specimen 179-6. The film used had a 20 MSI modulus and a 133 KSI strength. These values indicate the level of composite properties which can be achieved with graphite film composites.

VI. CONCLUSIONS & RECOMMENDATIONS

6.1 Conclusions

As a result of the investigative work done in this program and the analysis of the data previously discussed, we conclude that:

1. thin, multi ply composites can be constructed using Pfizer's thin pyrolytic graphite film and a polymeric matrix;

2. composites can be fabricated, with the existing graphite film, which are equal to or superior to quasi isotropic composites fabricated with graphite fibers of higher strength and modulus than this film.

3. film composites can be fabricated with an average efficiency greater than 50 percent with respect to reinforcement strength and modulus.

4. the film composites may exhibit strength levels higher than those predicted by single film tests;

In addition, based on the experimental results of this program, we tentatively conclude that:

1. the graphite film and full ply composites fabricated using this material are isotropic within the plane of the film and differences observed in this program are attributable to ripples in the film and edge defects;

2. the preferred composite structure is that which consists of either full sheet plies or narrow, parallel strips of film (ribbon) in 0°-90° alternating plies. (It should be noted that discontinuous film reinforcement gave higher efficiencies in a limited number of tests.)

3. a film reinforcement loading over eighty (80) volume percent is attainable without adversely affecting composite properties;

4. the testing of the graphite film should be carried out using a one-half (1/2) inch gage length tensile specimen; and

5. a material flexural test may be used in alignment problems associated with the latter. place of the tensile test in order to eliminate

6.2 Recommendations

In order to verify the tentative conclusions made on the basis of this exploratory work and to further develop pyrolytic graphite film as a composite reinforcement material, we make the following recommendations.

6.2.1 Test Methods

1. Further work should be carried out on the two material flexure test with both the basic graphite film and composite structures.

2. Optical strain measuring methods should be developed for use in measuring the tensile properties of the film and composite specimens. This should include both 0° and 90° measurements for the calculation of Poissons ratio.

3. Quantitative test methods should be developed to measure the bond strength of the film/matrix combination.

6.2.2 Composite Structures

1. Additional work should be carried out on film composites to verify the conclusions drawn from the present program on isotropy, composite structure, and reinforcement volume percent.

2. Large film composite specimens should be prepared in the form of flat plates in order that measurements can be made of shear strength shear modulus and information can be collected on the fabrication of large film composite panels.

3. A research program should be conducted on the bonding mechanism between the film and various matrix materials in an effort to optimize the material system.

4. Properties normal to the composite plane should be measured for graphite film composites and compared with those for fiber composites.

5. Methods for reducing the scatter of both film and composite properties should be investigated.

VII. REFERENCES

1. PADAWER, G. E. *The Strength of Bolted Connections in Graphite/Epoxy Composites Reinforced by Colaminated Boron Film*. Composite Materials: Testing and Design (Second Conference), ASTM STP 497, American Society for Testing Materials, 1972, p. 396-414.
2. PADAWER, G. E. *Film Reinforced Multi-Fastened Mechanical Joints in Fibrous Composites*. National Research Corporation, NAVAIR Contract N00019-71-C-0435, AIAA Paper No. 72-382, American Institute of Aeronautics and Astronautics, New York, 1972.
3. PADAWER, G. E. *The Notch Sensitivity of Boron Film Reinforced Composites*. National Research Corporation, Contract F 33615-71-C-1606, AFML, June, 1972.
4. BRANDMAIER, H. E., KATZ, H. S., and McINNIS, W. F. *Molding Composite Compressor Blades from Preimpregnated Composite Materials*. SAMPE Quarterly, v. 6, no. 3, April 1970, p. 1-14.
5. HERMANS, J. J. *Elastic Properties of Fiber Reinforced Materials When the Fibers are Aligned*. Proceedings Royal Academy Amsterdam, v. B70, 1967, p. 1-9.
6. HALPIN, J. C. *Effect of Environmental Factors on Composite Materials*. AFML-TR-67-423, June 1969.
7. CHEN, P. E. and LEWIS, T. B. *Stress Analysis of Ribbon Reinforced Composites*. Polymer Engineering and Science, v. 10, no. 1, January 1970, p. 43-47.
8. TSAI, S. W. *Strength Theories of Filamentary Structures*. Fundamental Aspects of Fiber Reinforced Plastic Composites, Interscience Publishers, New York, 1968.
9. POESCH, J. G. *Development of Lightweight Graphite/Polyimide Sandwich Panels*. Fourth National SAMPE Technical Conference, October 17-19, 1972.
10. HALPIN, J. C. and THOMAS, R. L. *Ribbon Reinforcement of Composites*. AFML-TR-69-33, 1969.
11. HALPIN, J. C. and THOMAS, R. L. *Ribbon Reinforcement of Composites*. Journal of Composite Materials, v. 2, no. 4, October 1968, p. 488-497.
12. *Composite Design Guide for Advanced Composite Applications, VI Material Characterization*. Second Edition, AFML, January 1971, Section 7.
13. FROBERG, R. W.; CONABEE, E. E.; and STANLEY, H. D. *Properties of Thin Pyrolytic Graphite Film*. Abstracts of Tenth Biennial Conference on Carbon, Lehigh University, 1971, p. 231-232.

GENERAL REFERENCES

1. JONES, B. H. *Strength and Fracture Characteristics of Filamentary Composites*. ASME 70-DE-31, 1970.
2. McDULLOUGH, R. L. *Fundamental Concepts of Composite Materials*. Boeing Scientific Research Laboratory, Report D 1-82-0970, April 1970, p. 41-58.
3. BEECHER, N.; FEAKES, F.; and ALLEN, L. R. *Laminar Film Reinforcements for Structural Applications*. Paper NR-3, Advances in Structural Composites, SAMPE, v. 12, Western Periodicals Co., Hollywood, California, 1967.
4. CHADSEY, E. E. and FEAKES, F. *Thin Film Structural Reinforcements for High Performance Composites*. AFML-TR-68-92, April 1968.
5. CRAWFORD, R. F. *An Evaluation of Boron-Polymer Film Layer Composites for High Performance Structures*. NASA CR-1114, September 1968.
6. STANLEY, H. D. and FORBERG, R. W. *Unusual Structural Characteristics of a Unique Thin Pyrolytic Graphite Film*. Tenth Biennial Conference on Carbon, Lehigh University, 1971.

APPENDIX A

Raw Pyrolytic Graphite Film Tensile Data

COLUMN HEADINGS

1. Sample Number
2. Test Data
3. Thickness - Mills
4. Width - Inches
5. Gage Length - Inches
6. Failure Load - Pounds
7. Tensile Strength - KSI
8. & 9. Change in elongation ΔL for a change in load ΔF over the linear portion of the curve.
10. Linear (L) or non-linear (N) load-elongation curve.
11. Modulus - MSI
12. Failure Strain - Mills per inch. (This is ten times percent elongation at failure.)
13. Specific Gravity
14. Indication of which films were not included in averaging due to low modulus and/or strength compared to other values in sample.

PYROLYTIC GRAPHITE FILM TENSILE DATA

Sample	Date	Thk. Mils	Width In.	Gage In.	Load Lbs.	Failure	TS KSI
101	4/18	.20	.0671	.961	.59		44.0
101		.20	.0671	.986	.65		51.4
101		.20	.0646	.968	.35		27.1
108		.30	.0670	.980	.43		21.4
108		.30	.0591	.968	.38		21.4
108		.30	.0561	.947	.54		32.1
117		.24	.0660	.959	.58		36.6
117		.24	.0850	.952	1.31		64.2
117		.24	.0800	.983	1.06		55.2
125		.22	.0661	.964	.62		42.6
125		.22	.0602	.967	.40		30.2
125		.22	.0582	.973	.46		35.9
267		.26	.0571	.977	.74		49.8
267		.26	.0501	.957	.66		50.7
267		.26	.0545	.962	.64		45.2
268		.30	.0516	.941	.43		27.8
268		.30	.0503	.965	.58		38.4
268		.30	.0563	.972	.69		40.9
33	4/20	.34	.0800	.961	.24		8.82
33		.34	.0820	.958	.34		12.2
33		.34	.0840	.966	.82		28.7
107		.25	.0654	.966	.19		11.6
107		.25	.0651	.964	1.22		75.0
110		.26	.0700	.950	.98		53.8
110		.26	.0577	.966	1.40		93.3
110		.26	.0620	.954	.40		24.8
126		.21	.0800	.965	.84		50.0
126		.21	.0647	.958	1.00		73.6
126		.21	.0671	.958	.82		58.2
139		.20	.0600	.964	.70		58.3
139		.20	.0680	.923	.67		49.3
139		.20	.0658	.960	.72		54.7
146		.24	.0740	.941	1.22		68.7
146		.24	.0631	.966	.28		18.5
245		.20	.0687	.939	.40		29.1
245		.20	.0840	.986	.33		19.6
245		.20	.0800	.956	.35		21.9
255		.18	.0694	.969	.54		43.2
263		.20	.0692	.954	.34		24.6

PYROLYTIC GRAPHITE FILM TENSILE DATA

Sample	Date	Linear		N or L	Modulus E MSI	Fail. Str. Mils./In.	SG	Not in Avg.
		ΔF Lbs.	ΔL Mils					
101	4/18	.59	8.15	L	5.32	8.27	2.01	
101		.65	8.75	L	6.16	8.34		
101		.35	5.4	L	4.97	5.46		X
108		.43	3.8	L	5.74	3.73	1.46	
108		.31	3.0	N	7.16	5.85	1.35	
108		.54	4.7	L	6.73	4.77		
117		.3	3.4	N	5.51	6.62	1.46	
117		1.31	10.2	L	6.14	10.20	1.79	
117		1.06	9.75	L	5.78	9.55		
125		.62	9.45	L	4.44	9.58	1.41	
125		.4	6.7	L	4.45	6.79	1.46	
125		.46	7.05	L	5.07	7.03		
267		.74	7.55	L	6.67	7.47	1.63	
267		.66	7.25	L	6.91	7.34	1.39	
267		.66	6.65	L	6.77	6.68		
268	.41	4.3	N	5.99	4.42	1.53		
268	.5	5.1	N	6.49	6.32			
268	.57	4.9	N	8.45	4.84			
33	4/20	.24	2.6	L	3.35	2.63	2.193	
33		.34	3.4	L	3.55	3.44		
33		.82	7.9	L	3.62	7.92		
107		.19	2.55	L	4.50	2.58	2.146	X
107		.4	4.6	N	5.29	15.50		
110		.98	8.7	L	6.08	8.85	2.003	
110		.4	3.75	N	7.09	13.30		
110		.4	3.85	L	6.34	3.91		
126		.84	8.35	L	5.96	8.39	1.597	
126		1.02	11.8	L	6.13	12.00		
126		.82	8.85	L	6.48	8.98		
139		.7	9.55	L	6.02	9.69	1.827	
139		.67	9.40	L	4.94	9.97		
139		.72	10.8	L	4.97	11.00		
146		1.22	11.45	L	5.82	11.80	1.914	
146	.28	3.15	L	5.84	3.17		X	
245	.40	7.0	L	3.97	7.33	2.081		
245	.33	5.2	L	3.79	5.17			
245	.35	5.45	L	3.92	5.59			
255	.54	7.75	L	5.52	7.83	1.901		
263	.34	5.25	L	4.56	5.40	1.665		

PYROLYTIC GRAPHITE FILM TENSILE DATA

Sample	Date	Thk. Mils	Width In.	Gage In.	Load Lbs.	Failure TS KSI
272	4/20	.20	.081	.951	1.67	103.0
272		.20	.059	.936	1.29	109.0
272		.20	.0645	.961	1.00	77.5
276		.20	.066	.974	1.26	95.5
276		.20	.0602	.953	.54	44.9
276		.20	.0631	.946	.61	48.3
280		.20	.0584	.970	.80	68.5
280		.20	.0810	.939	1.46	90.1
280		.20	.0796	.931	.37	23.2
282		.27	.0710	.960	1.10	57.4
282		.27	.0736	.960	.92	46.3
282		.27	.0723	.955	.52	26.6
285		.24	.0628	.972	.72	47.8
285		.24	.0675	.940	1.21	74.7
285		.24	.0770	1.002	1.53	82.8
29	3/29	.2	.0626	.943	.20	16.0
29		.2	.0514	.943	.31	30.2
29		.2	.0500	.923	.65	65.0
29		.2	.0496	.963	.20	20.2
39		.25	.0683	.960	.65	38.1
39		.25	.0700	.960	.73	41.7
39		.25	.0480	.940	.48	40.0
111		.2	.0630	.926	1.19	94.4
111		.2	.0631	.948	1.18	93.5
111		.2	.0700	.969	.92	65.7
111		.2	.0720	.954	1.13	78.5
124		.2	.0665	.960	.53	39.8
124		.2	.0720	.945	1.33	92.4
124		.2	.0624	.978	.49	39.3
124		.2	.0540	.967	.63	58.3
135		.2	.0491	.970	.43	43.8
135		.2	.0684	.954	.44	32.2
135		.2	.0460	.975	.22	23.9
142		.2	.0532	.965	.23	21.6
142		.2	.0595	.954	.31	26.1
142		.2	.0600	1.006	.45	37.5
142		.2	.0605	.969	.30	24.8

PYROLYTIC GRAPHITE FILM TENSILE DATA

Sample	Date	Linear		N or L	Modulus E MSI	Fail. Str. Mils./In.	SG	Not in Avg.
		ΔF Lbs.	ΔL Mils					
272		1.67	12.3	L	8.31	12.40	1.880	X
272		1.29	12.3	L	8.58	12.70		
272		1.00	8.5	L	9.09	8.53		
276		1.26	10.35	L	9.18	10.40	2.063	
276		.54	4.85	L	9.13	4.92		
276		.61	5.2	L	9.29	5.30		
280		.82	7.05	L	9.77	7.01	1.692	
280		1.46	11.6	L	7.57	11.90		
280		.37	3.5	L	6.37	3.64		X
282		1.10	9.2	L	6.21	9.24	1.743	
282		.92	7.1	L	6.51	7.11		
282		.52	4.6	L	5.72	4.65		X
285		.72	6.55	N	7.33	6.52	1.803	
285		1.21	9.95	L	7.32	10.20		
285		1.53	12.1	L	7.14	11.60		
29	3/29	.2	3.3	L	4.66	3.43	1.764	X
29		.31	5.7	L	5.08	5.95		
29		.65	10.1	L	6.07	10.70		
29		.2	3.6	L	5.50	3.67		
39		.65	6.5	L	5.81	6.56	1.520	
39		.73	7.35	L	5.62	7.42		
39		.48	9.0	L	4.25	9.42		
111		1.19	9.8	L	9.25	10.20	1.451	
111		1.18	9.75	L	9.44	9.90		
111		.92	7.55	L	8.76	7.50		
111		1.13	8.4	L	9.30	8.44		
124		.53	3.8	L	10.50	3.79	1.686	
124		1.33	7.45	L	12.40	7.45		
124		.49	3.9	L	9.90	3.97		
124		.63	5.8	L	10.10	5.80		
135		.43	7.9	L	5.47	8.01	1.434	
135		.44	6.6	L	4.75	6.78		
135		.22	4.8	L	4.93	4.85		
142		.23	4.9	L	4.32	5.00	1.471	
142		.31	5.8	L	4.36	5.98		
142		.39	7.55	N	4.40	7.37		
142		.3	5.85	L	4.18	5.94		

PYROLYTIC GRAPHITE FILM TENSILE DATA

Sample	Date	Thk. Mils	Width In.	Gage In.	Load Lbs.	Failure TS KSI
152	3/29	.25	.0624	.976	.49	31.4
152		.25	.0590	.963	.56	38.0
152		.25	.0658	.969	.51	31.0
152		.25	.0558	.983	.42	30.1
152		.25	.0634	.962	.60	37.9
175		.25	.0631	.962	.49	31.1
175		.25	.0520	.949	.32	24.6
175		.25	.0610	.966	.56	36.7
175		.25	.0648	.948	.60	37.0
175		.25	.0616	.953	.49	31.8
97	5/22	.25	.073	.950	1.44	78.9
97		.25	.080	.937	1.05	52.5
97		.25	.081	.960	1.54	76.0
262		.30	.0693	1.075	1.12	53.9
262		.30	.0603	.961	1.12	61.9
269		.20	.07	.969	1.06	75.7
269		.20	.06	.950	1.22	102.0
269		.20	.0635	.965	.84	66.1
292		.32	.0552	.952	1.71	96.8
292		.32	.0551	.972	.63	35.7
292		.32	.052	.946	1.30	78.1
297		.32	.06	.930	1.18	63.4
297		.31	.0598	.981	1.34	72.3
297		.31	.0788	.957	2.00	81.9
300		.20	.08	.967	.78	48.8
300		.20	.0825	.955	.71	43.0
300		.20	.0671	.971	.58	43.2
302		.23	.0671	.974	.63	40.8
302		.23	.072	.961	.90	54.3
302		.23	.078	.962	.78	43.5
310		.18	.067	.997	.41	34.0
310		.18	.065	.986	.60	51.3
310		.18	.0692	1.005	.50	40.1
312		.27	.06	.910	1.06	65.4
312		.27	.078	.963	1.43	67.9
312		.27	.0651	.961	1.39	79.1
314		.22	.077	.953	.84	49.6
314		.22	.080	.951	.72	40.9
314		.22	.0657	.967	.80	55.3
315		.25	.0775	.958	.93	48.0

PYROLYTIC GRAPHITE FILM TENSILE DATA

Sample	Date	Linear		N or L	Modulus E MSI	Fall. Str. Mils/In.	SG	Not in Avg.
		ΔF Lbs.	ΔL Mils					
152	3/29	.5	4.3	L	7.39	4.25	2.011	
152		.54	5.0	N	7.30	5.02		
152		.51	4.95	L	6.26	4.95		
152		.42	4.0	L	7.64	3.94		
175		.6	4.75	L	8.00	4.74		
175		.49	4.1	L	7.59	4.10		1.722
175	.32	3.05	L	7.91	3.11			
175	5/22	.56	4.6	L	7.98	4.58		
175		.6	4.7	L	7.77	4.76		
175		.39	6.15	N	5.02	6.33		
97		.4	4.2	N	5.14	14.60	1.774	
97		1.05	12.85	L	3.95	13.30		X
97		.4	4.15	N	4.74	16.80		
262		1.12	5.8	L	10.80	5.00	1.964	
262		1.12	8.15	L	7.70	8.04		
269		1.06	11.2	L	6.82	11.10	1.789	
269		.4	4.05	N	8.12	13.00		
269		.84	8.5	L	7.79	8.48		
292	.4	3.2	N	7.07	14.50	1.904		
292	.63	5.75	L	6.30	5.67			
292	.4	4.1	N	5.76	14.10			
297	1.18	9.5	L	6.52	9.73	1.943		
297	.4	3.4	N	6.12	12.40			
297	.4	2.6	N	6.40	13.30			
300	.4	3.95	N	6.37	7.97	1.852		
300	.71	8.1	L	5.24	8.20			
300	.4	4.2	N	7.15	7.03			
302	.63	6.25	L	6.61	6.17	1.935		
302	.90	8.2	L	6.64	8.18			
302	.78	5.25	L	8.45	5.15			
310	.41	4.9	L	7.12	4.76	1.747		
310	.61	6.8	L	7.70	6.66			
310	.5	6.2	L	6.71	5.98			
312	1.06	9.4	L	6.61	9.89	1.957		
312	.4	3.25	N	5.90	12.40			
312	.4	3.3	N	6.95	11.80			
314	.4	2.9	N	8.19	6.17	1.169		
314	.4	3.0	N	7.59	5.86			
314	.8	6.2	L	9.07	6.10			
315	.4	3.4	N	6.09	8.09	1.713		

PYROLYTIC GRAPHITE FILM TENSILE DATA

Sample	Date	Thk. Mils	Width In.	Gage In.	Load Lbs.	Failure	TS KSI
315	5/22	.25	.0463	.967	.56		48.4
315		.25	.0687	.960	1.14		66.4
319		.38	.0785	.979	1.12		37.5
319		.38	.0690	.984	1.10		42.0
319		.38	.0721	.977	1.86		67.9
281	6/27	.20	.0663	.966	.15		11.3
321		.21	.0596	.935	1.47		117.0
321		.21	.0504	.933	1.28		121.0
319		.20	.060	.960	1.56		130.0
319		.20	.0603	.962	.51		42.3
319		.20	.062	.960	.71		57.2
318		.20	.0586	.960	.56		47.8
318		.20	.058	.954	.78		82.2
318		.20	.0543	.951	.75		69.1
291		.20	.064	.955	.82		64.1
291		.20	.0676	.966	.56		41.2
286		.29	.080	.979	.90		38.8
286		.29	.085	.970	.62		25.2
284		.32	.0534	.930	1.30		76.1
284		.32	.0505	.975	.47		29.1
284		.32	.0542	.974	1.02		58.8
279		.22	.044	.975	.44		45.6
279		.22	.0482	.975	.32		30.2
278		.38	.07	.963	.22		11.7
278		.38	.0496	.972	.85		45.1
278		.38	.0575	1.132	.92		42.1
260		.31	.0565	.977	.54		30.8
260		.31	.0559	.953	.88		50.8
260		.31	.0697	.942	.93		43.0
242		.31	.071	.945	.95		43.2
242		.31	.0578	.967	.74		41.3
242		.31	.08	.971	.94		37.9
102		.14	.0649	.965	.71		78.1
102		.14	.0573	.969	.35		43.6
102		.14	.0560	.951	.12		15.3
53		.41	.0605	.964	1.09		43.9
53		.41	.0668	.956	1.28		46.7
53		.41	.06	.943	.48		19.5

PYROLYTIC GRAPHITE FILM TENSILE DATA

Sample	Date	Linear		N or L	Modulus E MSI	Fall. Str. Mils/In.	SG	Not in Avg.
		ΔF Lbs.	ΔL Mils					
315	5/22	.56	7.1	L	6.80	7.12		
315		1.14	8.9	L	7.53	8.82		
319		1.12	6.2	L	6.36	5.90	1.691	
319		1.1	6.05	L	7.34	5.72		
319		1.86	11.75	L	6.01	11.30		
281	6/27	.15	.35	L	3.15	3.59	1.254	X
321		.4	3.75	N	8.16	15.20	1.559	
321		1.28	13.5	L	8.52	14.20		
319		.4	3.85	N	8.51	16.00	1.323	
319		.4	5.2	N	6.24	8.10		
319		.4	7.9	N	3.96	7.85		
318		.4	7.8	N	4.42	11.70	1.375	
318		.4	7.4	N	4.81	15.20		
318		.4	7.0	N	5.07	14.40		
291		.4	5.0	N	6.08	10.80	1.382	
291		.56	8.0	L	5.06	8.15		
286		.4	4.95	N	3.47	11.90	1.614	
286		.62	6.45	L	3.87	6.51		
284		.4	4.35	N	5.11	16.80	1.648	
284		.47	4.7	L	6.18	4.71		X
284		.4	4.4	N	5.21	12.90		
279		.44	11.05	L	4.07	11.20	1.248	
279		.2	5.7	N	3.25	12.20		
278		.22	2.3	L	5.06	2.31	1.235	X
278		.4	5.3	N	3.96	14.10		
278		.4	4.85	N	4.35	10.20		
260		.54	5.5	L	5.59	5.51	1.549	
260		.4	4.25	N	5.29	10.20		
260		.4	3.55	N	5.04	8.70		
242		.4	5.5	N	3.17	15.00	1.563	
242		.4	5.45	N	4.03	10.40		
242		.94	10.5	L	3.58	10.60		
102		.4	7.4	N	5.81	15.60	1.237	
102		.35	6.9	L	6.19	7.04		
102		.12	2.25	L	6.54	2.34		X
53		.4	5.3	N	2.98	17.10	1.190	
53		.4	4.6	N	3.09	15.70		
53		.4	5.7	N	2.73	7.63		X

PYROLYTIC GRAPHITE FILM TENSILE DATA

Sample	Date	Thk. Mils	Width In.	Gage In.	Load Lbs.	Failure TS KSI
13	10/10	.1	.0580	1.003	.57	98.3
13		.1	.0562	.983	.66	117.4
13		.1	.0575	.998	.76	132.1
20		.2	.0725	.968	1.14	78.6
20		.2	.0578	1.046	.72	62.3
20		.2	.0609	.954	.40	32.8
179		.1	.0578	.993	.78	135.0
179		.1	.0583	.994	.76	130.0
205		.2	.0427	.957	.69	80.8
205		.2	.0500	.966	.60	60.0
248		.2	.0497	.999	.84	84.5
248		.2	.0492	1.013	.88	89.4
248		.2	.0449	.985	.42	60.2
249		.1	.0601	1.022	1.05	95.2
304		.2	.0525	.956	1.00	95.2
304		.2	.0437	.936	1.07	122.0
304		.2	.0601	.942	1.32	110.0
305		.2	.0623	.960	1.12	89.9
305		.2	.0566	.962	.80	70.7
309		.2	.0524	.967	1.04	99.2
309		.2	.0601	1.054	.78	64.9
309		.2	.0577	.950	1.10	95.3
77	10/18	.2	.0421	.270	.56	66.5
77		.2	.0462	.288	1.74	188.0
77		.2	.0422	.307	1.30	154.0
77		.2	.0468	.488	1.27	135.7
77		.2	.0389	.506	1.66	213.0
77		.2	.0412	.502	1.40	169.9
77		.2	.0475	.758	1.50	157.9
77		.2	.0356	.739	1.22	171.3
77		.2	.0532	.987	.86	80.8
77		.2	.0469	.999	.54	57.6
77		.2	.0500	1.001	1.36	136.0
181		.2	.0540	.990	1.00	92.6
181		.2	.0513	.995	.96	93.6
181		.2	.0501	.984	.72	71.9
181		.2	.0452	.977	.56	61.9
181		.2	.0590	.980	1.10	93.2
181		.2	.0568	.997	1.53	134.7
181		.2	.0458	.995	.90	98.3

PYROLYTIC GRAPHITE FILM TENSILE DATA

Sample	Date	Linear		N or L	Modulus E MSI	Fail Str. Mils/In.	SG	Not in Avg.
		Δ F Lbs.	Δ L Mils					
13	10/10	.57	6.5	L	15.6	6.31		
13		.40	5.7	N	12.5	9.77		
13		.76	7.7	L	17.6	7.49		
20		1.14	8.1	L	9.81	8.01		
20		.72	8.0	L	8.37	7.44		
20		.40	6.8	L	4.69	7.00		X
179		.40	3.5	N	20.3	6.78		
179		.40	3.7	N	19.0	7.72		
205		.69	5.9	L	13.6	5.95		
205		.60	4.95	L	12.1	4.94		
248		.84	8.50	L	10.2	8.26		
248		.88	8.45	L	10.7	8.34		
248		.42	7.3	L	8.27	7.28		X
249		.40	4.3	N	16.3	11.10		
304		1.00	7.75	L	12.2	7.79		
304		.40	3.15	N	14.1	9.17		
304		1.32	7.75	L	14.1	7.81		
305		1.12	8.00	L	11.3	7.98		
305		.40	4.3	N	8.13	9.63		
309		1.04	8.1	L	12.3	8.05		
309		.40	2.8	N	13.1	7.27		X
309		.40	2.7	N	12.8	7.86		
77	10/18	.56	2.1	L	9.10	7.31		
77		1.74	4.85	L	12.1	15.5		
77		1.30	5.1	L	9.81	15.7		
77		.4	1.75	N	12.6	14.1		
77		1.66	7.55	L	15.0	14.2		
77		1.40	7.45	L	12.0	14.2		
77		1.50	10.15	L	12.2	12.9		
77		1.22	11.0	L	11.8	14.5		
77		.86	7.3	L	11.2	7.2		
77		.54	5.2	L	11.3	5.08		
77		1.36	10.6	L	13.2	10.3		
181		1.00	9.30	L	10.1	9.17		
181		.96	9.60	L	9.93	9.43		
181		.72	8.4	L	8.56	8.37		
181		.56	6.2	L	10.2	6.22		
181		.4	3.3	N	10.7	4.65		
181		.4	3.2	N	11.6	6.18		
181		.9	9.2	L	10.7	9.04		

PYROLYTIC GRAPHITE FILM TENSILE DATA

Sample	Date	Thk. Mils	Width In.	Gage In.	Load Lbs.	Failure	TS KSI
181	10/18	.2	.0573	.995	1.16		101.2
181		.2	.0500	.986	.62		62.0
181		.2	.0491	.990	1.1		112.0
181		.2	.0578	.965	1.5		129.8
143		.2	.0600	.989	.99		85.6
143		.2	.0452	.994	.80		88.5
143		.2	.0535	1.005	1.12		104.7
233		.2	.0485	.995	.64		66.0
233		.2	.0478	.982	.84		87.9
233		.2	.0484	.950	.72		74.4
254		.3	.0470	.991	.53		37.6
254		.3	.0519	.991	.82		52.7
254		.3	.0415	1.026	1.13		90.8
256		.3	.0472	1.022	.56		39.5
256		.3	.0480	.974	.65		45.1
256		.3	.0478	.990	.94		65.6
301		.3	.0550	.982	.66		40.0
301		.3	.0408	.994	.69		56.4
301		.3	.0473	1.014	1.29		90.9

PYROLYTIC GRAPHITE FILM TENSILE DATA

Sample	Date	Linear AF Lbs.	Δ L Mils	N or L	Modulus E MSI	Fail. Str. Mils/in.	SG	Not in Avg.
181	10/18	.4	3.6	N	10.3	3.36		
181		.62	6.6	L	9.39	6.55		
181		1.1	10.0	L	11.4	9.85		
181		.8	6.25	N	11.0	10.0		
143		.99	7.4	L	11.8	7.26		
143		.80	7.8	L	11.5	7.67		
143		1.12	10.8	L	9.97	10.5		
233		.64	6.85	L	9.79	6.74		
233		.84	9.3	L	9.47	9.28		
233		.4	4.55	N	8.80	8.51		
254		.4	3.9	N	7.38	5.73		
254		.82	8.0	L	6.68	7.89		
254		.4	3.95	N	8.54	11.9		
256		.56	6.35	L	6.49	6.09		
256		.4	4.15	N	7.29	7.19		
256		.94	7.25	L	9.23	7.11		
301		.66	4.95	L	8.18	4.89		
301		.69	6.4	L	8.98	6.28		
301		1.40	3.3	N	8.90	11.8		

APPENDIX B
Pyrolytic Graphite Film Data Summary

COLUMN HEADINGS

1. Sample Number
2. Thickness - Mils
3. Specific Gravity
4. Number of Specimens Tested
5. Average Tensile Strength - KSI
6. Average Failure Strain - Mils per inch
7. Average Modulus - MSI

PYROLYTIC GRAPHITE FILM DATA SUMMARY

Sample	Thk. Mils	SG	No. of Samples	TS KSI	Fall. Str. Mils/In.	E MSI
13	.10	—	3	116.0	7.86	15.2
20	.20	—	2	70.5	7.73	9.09
29	.20	1.76	4	32.9	6.77	5.33
33	.34	2.19	3	16.6	4.66	3.51
39	.25	1.52	3	39.9	7.80	5.23
53	.41	1.19	2	45.3	16.40	3.04
97	.25	1.77	2	77.5	14.90	15.10
101	.20	2.01	2	47.7	8.31	5.74
102	.14	1.24	2	60.9	11.30	6.00
107	.25	2.15	1	75.0	15.50	5.29
108	.30	1.41	3	25.0	4.80	3.83
110	.26	2.00	3	57.3	8.69	6.50
111	.20	1.45	4	83.0	9.01	9.19
117	.24	1.61	3	52.0	8.79	5.81
124	.20	1.69	4	57.5	5.25	10.70
125	.22	1.44	3	36.2	7.80	4.65
126	.21	1.60	3	60.6	9.79	6.19
135	.20	1.43	3	33.3	6.55	5.05
139	.20	1.83	3	54.1	10.20	5.31
142	.20	1.47	3	29.5	6.07	4.31
146	.24	1.91	1	68.7	11.80	5.82
152	.25	2.01	5	33.7	4.58	7.32
175	.25	1.72	5	32.2	4.58	7.25
179	.10	—	2	133.0	7.25	19.70
205	.20	—	2	70.4	5.45	12.90
242	.31	1.56	3	40.8	12.00	3.59
245	.20	2.08	3	23.5	6.03	3.89
248	.20	—	2	87.0	8.30	10.50
249	.10	—	1	95.2	11.10	16.30
255	.18	1.90	1	43.2	7.83	5.52
260	.31	1.55	3	41.5	8.14	5.31
262	.30	1.96	2	57.9	6.52	9.25
263	.20	1.67	1	24.6	5.40	4.56
267	.26	1.51	3	48.6	7.16	6.78
268	.30	1.53	3	35.7	5.19	6.98
269	.20	1.79	3	81.3	10.90	7.58
272	.20	1.88	3	96.5	11.60	8.66
276	.20	2.06	3	62.9	6.87	9.20
278	.38	1.24	2	43.6	12.20	4.16
279	.22	1.25	2	37.9	11.70	3.66

PYROLYTIC GRAPHITE FILM DATA SUMMARY

Sample	Thk. Mils	SG	No. of Samples	TS KSI	Fail. Str. Mils/in.	E MSI
280	.20	1.69	2	79.3	9.45	8.67
282	.27	1.74	2	51.9	8.18	6.36
284	.32	1.68	2	67.5	14.90	5.16
285	.24	1.80	3	68.4	9.44	7.26
286	.29	1.61	2	35.1	9.21	3.67
291	.20	1.38	2	52.7	9.48	5.57
292	.32	1.90	3	70.2	11.40	6.38
297	.31	1.94	3	72.5	11.80	6.35
300	.20	1.85	3	45.0	7.73	6.25
302	.23	1.94	3	46.2	6.50	7.23
304	.20	—	3	109.0	8.26	13.50
305	.20	—	2	80.3	8.81	9.72
309	.20	—	2	97.3	7.96	12.60
310	.18	1.75	3	41.8	5.80	7.18
312	.27	1.96	3	70.8	11.40	6.49
314	.22	1.17	3	48.6	6.04	8.28
315	.25	1.71	3	54.3	8.01	6.81
318	.20	1.38	3	66.4	13.80	4.77
319	.20	1.32	3	76.5	10.70	6.24
319	.38	1.69	3	49.1	7.64	6.57
321	.21	1.56	2	119.0	14.70	8.34

$TS_{Av} = 57.6 \text{ KSI}$

$E_{Av} = 7.1$

No. of Samples = 161

APPENDIX C
Raw Composite Tensile Data

COLUMN HEADINGS

1. Sample Number
2. Test Date
3. Number of Plies
4. Filament Orientation
 - L—Ripples parallel to specimen length
 - C—Ripples transverse to specimen length
5. Composite Structure (Geometry)
 - F—Full Ply T—Tile
 - S—Strip
 - TS—Thin Strip
 - P—Middle Plies Perforated
6. Matrix
 - A—Ciba Araldite 6004 Epoxy Resin + 20 PHR Shell Catalyst Z.
 - B—Ciba Araldite 6004 Epoxy Resin + General Mills Versamide 140; equal parts by weight.
 - C—Ciba Araldite 6004 + Hexahydrophthalic Anhydride (70 PHR) + Argus DB-VIII (2 PHR).
 - D—Union Carbide ERLA 4617 Epoxy Resin + m-Phenylene diamine (25 PHR) + BF₃-Mono ethylamine (1.5 PHR). E4MB
 - E—Dupont Adiprene 315 Urethane Resin + MOCA Catalyst (26 PHR).
7. Specimen Width, Inches
8. Gage Length, Inches
9. Total Film Thickness, Mils
10. Composite Thickness, Mils
11. Failure Load, Pounds
12. Failure Mode
 - P—Progressive
 - C—Catastrophic
- 13 and 14. Change in observed elongation for a given change in load over the linear portion of the curve.
15. Failure Elongation

Sample	Date	No. Plies	Orient.	Structure	Matrix	Specimen	
						Width Ins.	Gage Ins.
T6B	4-27	6	C	F	B	0.494	1.0
T7	4-27	4	C	F	B	0.486	1.0
T8A	4-27	6	C	F	B	0.494	1.0
T9B	4-27	6	C	F	B	0.492	1.0
T10A	4-27	6	C	F	B	0.492	1.0
T11A	5-26	6	C	F	E	0.495	1.0
T11B	5-26	6	C	F	E	0.504	1.0
T11C	5-26	6	C	F	E	0.266	1.0
T12	5-6	6	C	F	D	0.500	1.0
T13B	5-6	6	C	F	D	0.502	1.0
T14A	6-7	6	C	F	D	0.500	1.0
T14B	6-7	6	L	F	D	0.500	1.0
276-1	5-26	6	C	F	B	0.188	0.62
TM1	5-1	6	C	F	B	0.18	0.5
TM2	5-1	6	C	F	B	0.18	0.5
TM3	5-1	6	C	F	B	0.19	0.5
TM4	5-1	6	C	F	B	0.18	0.5
TM5	5-1	6	C	F	B	0.18	0.5
SL1	5-5	4	C	S	B	0.509	1.0
SL2	5-5	4	C	S	B	0.525	1.0
SL3	5-19	6	C	S	B	0.5	1.0
SL4	5-19	6	C	S	B	0.5	1.0
SL5	5-26	6	C	S	B	0.501	1.0
SL6	6-7	6	L	S	D	0.5	1.0
SL7	6-15	6	C	S	E+D	0.5	1.0
13-4	8-9	4	C	F	A	0.244	0.595
13-6	8-9	6	C	F	A	0.259	0.561
20-4	8-9	4	C	T	A	0.257	0.352
20-4A	8-15	4	C	T	A	0.165	0.593
29-4	8-15	4	C	F	A	0.165	0.563
29-5	8-21	5	C	F	A	0.165	0.581
53-3	7-20	3	C	P	A	0.167	0.750
53-5	7-20	5	C	P	A	0.167	0.750
72-T3L	9-27	3	L	T	C	0.167	0.363
72-3C	9-27	3	C	F	C	0.250	0.449
97-8	7-25	8	C	F	A	0.167	0.609
102-4A	8-9	4	C	F	A	0.167	0.421
102-6	8-9	6	C	F	A	0.262	0.423
105-4	8-21	4	C	F	A	0.165	0.579
105-4A	8-21	4	C	F	A	0.162	0.513
105-4B	8-21	4	C	T	A	0.161	0.520
111-2L	9-15	2	L	F	C	0.170	0.440
111-4L	9-15	4	L	F	C	0.160	0.730
111-4C	9-15	4	C	F	C	0.250	0.690
124-4	8-21	4	C	F	A	0.163	0.420
178-4C	9-27	4	C	F	C	0.250	0.851

Sample	Date	Dimensions		Failure		Linear E		Failure Elong. (Mils)
		Film (Thk- Mils)	Comp (Thk- Mils)	Load (Lbs.)	Mode	ΔF (Lbs.)	ΔL (Mils)	
T6B	4-27	1.3	2.6	22.7	P	5.0	2.4	13.9
T7	4-27	0.7	3.5	25.0	P	5.0	2.5	13.0
T8A	4-27	1.6	3.5	34.5	—	—	—	—
T9B	4-27	1.3	3.0	26.0	C	4.0	1.35	10.5
T10A	4-27	1.2	3.0	23.7	C	5.0	2.25	11.8
T11A	5-26	1.8	3.4	19.5	P	5.0	2.45	11.3
T11B	5-26	1.7	3.8	28.0	C	5.0	2.5	14.5
T11C	5-26	1.5	4.2	14.8	P	3.0	1.6	8.5
T12	5-6	1.35	1.5	7.5	P	5.0	4.0	6.0
T13B	5-6	1.50	2.6	7.5	P	5.0	4.3	6.2
T14A	6-7	1.6	3.2	31.5	C	5.0	1.6	10.0
T14B	6-7	1.5	3.2	21.0	P	5.0	1.8	7.7
276-1	5-26	0.3	0.38	9.5	P	5.0	4.6	9.2
TM1	5-1	1.8	4.9	5.7	P	4.0	4.05	6.4
TM2	5-1	1.8	5.0	4.1	P	3.0	4.7	5.7
TM3	5-1	1.9	11.0	11.7	C	2.0	1.8	11.0
TM4	5-1	1.8	3.4	6.8	C	3.0	2.9	5.7
TM5	5-1	1.8	4.6	8.8	C	5.0	3.7	5.6
SL1	5-5	1.0	2.7	27.0	C	5.0	3.45	19.0
SL2	5-5	1.0	2.5	27.5	C	5.0	2.8	16.5
SL3	5-19	1.9	3.3	26.5	C	10.0	4.1	11.5
SL4	5-19	1.5	3.9	30.5	C	10.0	4.2	14.0
SL5	5-26	1.5	5.7	31.5	P	5.0	2.3	14.8
SL6	6-7	1.5	1.9	23.0	C	5.0	1.75	8.1
SL7	6-15	—	4.8	16.5	C	5.0	1.9	6.3
13-4	8-9	0.85	5.8	14.1	C	2.0	1.4	9.6
13-6	8-9	1.30	2.2	19.6	P	6.0	3.35	16.2
20-4	8-9	1.80	3.1	14.0	C	2.0	1.45	10.2
20-4A	8-15	1.80	5.0	4.0	C	2.0	2.75	5.7
29-4	8-15	1.80	3.2	7.7	P	2.0	1.95	10.3
29-5	8-21	1.10	2.8	6.8	C	3.0	3.00	7.0
53-3	7-20	0.60	3.4	3.1	P	1.0	1.70	5.1
53-5	7-20	0.95	2.5	4.4	C	2.0	2.70	6.0
72-T3L	9-27	0.45	1.3	2.1	P	2.1	2.50	2.5
72-3C	9-27	0.55	3.4	7.0	C	7.0	6.70	6.7
97-8	7-25	1.30	2.2	6.0	P	2.0	1.90	10.2
102-4A	8-9	0.56	3.0	6.7	P	2.0	1.70	5.8
102-6	8-9	0.84	3.3	16.6	C	4.0	2.00	13.5
105-4	8-21	1.35	4.5	8.9	P	3.0	2.50	7.6
105-4A	8-21	1.60	3.0	14.2	P	3.0	2.30	6.7
105-4B	8-21	0.90	2.1	7.7	P	3.0	2.60	7.5
111-2L	9-15	0.40	1.3	0.8	C	0.8	1.35	1.4
111-4L	9-15	0.80	1.8	4.4	C	4.4	5.40	5.4
111-4C	9-15	1.00	1.8	8.0	P	8.0	6.40	6.4
124-4	8-21	1.10	3.0	9.8	P	3.0	2.60	8.8
178-4C	9-27	1.00	3.1	4.5	C	4.5	3.90	3.9

Sample	Date	No. Plies	Orient.	Structure	Matrix	Specimen	
						Width Ins.	Gage Ins.
178-6L	9-27	6	L	F	C	0.167	0.642
179-4L	8-30	4	L	F	A	0.266	0.533
179-6	8-30	6	C	F	A	0.164	0.541
205-3	8-9	3	C	F	A	0.163	0.560
205-6	8-9	6	C	F	A	0.174	0.602
242-1	7-14	1	C	F	A	0.167	0.750
242-1A	7-14	1	C	F	A	0.167	0.500
242-2	7-14	2	C	F	A	0.167	0.625
242-3	7-14	3	C	F	A	0.167	0.750
242-4	7-14	4	C	F	A	0.167	0.750
248-6	7-25	6	C	F	A	0.167	0.652
248-6A	7-25	6	C	F	A	0.167	0.551
249-4	8-9	4	C	F	A	0.267	0.563
249-4A	8-9	4	C	F	A	0.163	0.520
249-4B	8-9	4	C	T	A	0.163	0.530
252-1	7-14	1	C	F	A	0.25	0.750
252-1A	7-14	1	C	F	A	0.25	0.750
252-3	7-14	3	C	F	A	0.25	0.625
252-4	7-14	4	C	F	A	0.25	0.750
253-1	8-16	1	C	F	C	0.157	0.365
253-2	8-16	2	C	F	C	0.176	0.280
253-2A	8-16	2	C	F	C	0.177	0.269
253-4	8-16	4	C	F	C	0.159	0.535
253-4A	8-16	4	C	F	C	0.163	0.486
266-4	8-30	4	C	F	A	0.168	0.500
266-5	8-30	5	C	F	A	0.164	0.449
266-5A	8-30	5	L	F	A	0.166	0.448
269-1	7-20	1	C	F	A	0.167	0.750
269-1A	7-20	1	C	F	A	0.167	0.750
269-2	7-20	2	C	F	A	0.167	0.750
269-3	7-20	3	C	F	A	0.167	0.750
269-4	7-20	4	C	F	A	0.167	0.750
271-1	7-3	1	C	F	A	0.250	0.750
274-1	7-3	1	C	F	A	0.250	—
274-1A	7-3	1	C	F	A	0.250	—
274-2	7-3	2	C	F	A	0.250	—
275-4	8-15	4	C	T	A	0.165	0.528
275-5	8-21	5	C	F	A	0.165	0.531
278-2	7-3	2	C	F	A	0.250	0.500
278-2A	7-3	2	C	F	A	0.250	0.500
278-4	7-3	4	C	F	A	0.250	0.500
279-1	6-27	1	C	F	D	0.250	0.500
279-4	6-27	4	C	F	D	0.250	0.750
281-1	7-3	1	C	F	D	0.250	0.500
281-2	7-3	2	C	F	D	0.250	0.750
281-2A	7-3	2	C	F	D	0.250	0.750

Sample	Date	Dimensions		Failure		Linear E		Failure Elong. (Mils)
		Film (Thk- Mils)	Comp (Thk- Mils)	Load (Lbs.)	Mode	ΔF (Lbs.)	ΔL (Mils)	
178-6L	9-27	1.40	3.2	5.80	P	5.8	4.85	4.9
179-4L	8-30	1.10	1.2	6.40	C	2.0	1.30	4.5
179-6	8-30	2.00	2.4	13.60	P	2.0	1.20	8.8
205-3	8-9	0.90	2.3	5.50	P	1.0	1.10	5.8
205-6	8-9	1.60	3.6	14.80	P	4.0	2.80	10.8
242-1	7-14	0.30	2.0	0.52	C	0.2	0.7	1.8
242-1A	7-14	0.30	1.2	1.54	C	1.0	2.75	3.2
242-2	7-14	0.55	2.3	0.64	C	0.4	0.90	1.4
242-3	7-14	0.80	2.4	3.00	C	1.0	1.60	4.8
242-4	7-14	1.10	4.3	7.30	P	2.0	2.20	8.8
248-6	7-25	1.28	2.5	13.80	P	2.0	1.70	13.5
248-6A	7-25	1.60	2.4	14.00	P	2.0	1.50	13.6
249-4	8-9	0.80	3.4	9.40	C	2.0	1.40	6.5
249-4A	8-9	1.00	1.4	7.70	C	2.0	1.70	7.2
249-4B	8-9	0.80	3.1	11.20	C	2.0	1.40	7.8
252-1	7-14	0.25	2.1	0.84	C	0.4	0.85	1.8
252-1A	7-14	0.25	1.3	0.56	C	0.2	0.50	1.3
252-3	7-14	0.80	1.3	5.00	C	2.0	1.80	4.5
252-4	7-14	1.20	1.8	18.50	C	5.0	3.90	14.2
253-1	8-16	0.15	1.6	1.64	C	0.4	0.80	3.2
253-2	8-16	0.20	2.0	1.62	P	0.4	0.60	2.4
253-2A	8-16	0.25	2.0	1.68	C	0.4	0.50	2.2
253-4	8-16	0.50	1.7	6.80	C	2.0	1.70	6.0
253-4A	8-16	0.55	2.1	6.15	C	2.0	2.30	7.1
266-4	8-30	0.90	2.3	8.20	C	2.0	1.50	6.1
266-5	8-30	1.30	2.4	12.20	P	2.0	1.25	7.6
266-5A	8-30	1.60	2.8	8.50	P	2.0	1.30	7.5
269-1	7-20	0.21	1.4	1.40	C	0.6	2.30	5.4
269-1A	7-20	0.21	1.8	0.62	C	0.2	0.80	3.3
269-2	7-20	0.50	2.1	4.60	P	2.0	4.30	7.6
269-3	7-20	0.65	3.6	6.90	P	2.0	3.40	11.6
269-4	7-20	0.80	3.2	8.40	P	2.0	2.30	12.6
271-1	7-3	0.20	0.7	2.1	C	1.0	2.20	4.3
274-1	7-3	0.30	1.1	3.4	C	1.0	1.90	7.5
274-1A	7-3	0.30	1.6	2.1	C	1.0	1.50	3.2
274-2	7-3	0.50	0.6	5.7	P	2.0	2.80	8.0
275-4	8-15	0.80	2.0	4.1	C	2.0	2.55	5.1
275-5	8-21	0.95	2.1	6.6	C	3.0	3.35	7.8
278-2	7-3	0.50	1.0	4.8	C	3.0	3.20	5.0
278-2A	7-3	0.50	3.4	4.1	P	2.0	1.85	4.3
278-4	7-3	1.00	2.1	8.2	P	5.0	3.55	6.9
279-1	6-27	0.30	1.6	1.7	C	1.0	3.50	6.0
279-4	6-27	1.20	2.0	5.9	P	1.0	0.90	5.6
281-1	7-3	0.20	—	1.4	C	0.5	1.00	2.8
281-2	7-3	0.40	0.6	9.2	C	5.0	6.40	11.9
281-2A	7-3	0.45	2.9	5.7	C	2.0	3.00	7.1

Sample	Date	No. Plies	Orient.	Structure	Matrix	Specimen	
						Width Ins.	Gage Ins.
281-4	7-3	4	C	F	D	0.250	0.750
284-2	7-3	2	C	F	D	0.250	1.000
286-2	6-27	2	C	F	D	0.250	0.500
286-2	6-27	2	C	F	D	0.250	0.500
286-3	7-3	3	C	F	D	0.250	1.000
288-1	8-16	1	C	F	C	0.164	0.555
288-4	8-16	4	C	F	C	0.165	0.580
288-6	8-16	6	C	F	C	0.157	0.608
291-1	6-27	1	C	F	D	0.250	1.000
291-2	7-3	2	C	F	D	0.250	0.750
291-2'	7-3	2	C	F	D	0.250	0.750
291-4B	6-27	4	C	B	D	0.250	1.000
291-4	6-27	4	C	F	D	0.250	0.750
296-1	7-25	1	C	F	A	0.167	0.634
296-2	7-25	2	C	F	A	0.167	0.695
296-6	7-25	6	C	F	A	0.167	0.686
297-4	8-9	4	C	T	A	0.265	0.620
297-4A	8-15	4	C	T	A	0.165	0.582
304-4T	8-30	4	C	T	A	0.163	0.766
304-4	8-30	4	C	F	A	0.166	0.572
304-6T	8-30	6	C	T	A	0.164	0.643
305-2	7-14	2	C	F	A	0.167	0.750
305-2(TS)	7-14	2	C	TS	A	0.167	0.750
305-6(TS)	7-14	6	C	TS	A	0.167	0.750
308-4	8-21	4	C	F	A	0.170	0.313
308-4B	8-21	4	C	T	A	0.163	0.519
309-6T	8-30	6	C	T	A	0.172	0.710
309-6AT	8-30	6	C	T	A	0.167	0.804
313-T3C	9-27	3	C	T	C	0.167	0.314
313-T3C'	9-27	3	C	T	C	0.167	0.446
313-T4C'	9-27	4	C	T	C	0.250	0.566
313-T6C	9-27	6	C	T	C	0.167	0.524
313-T6C'	9-27	6	C	T	C	0.250	0.784
316-4	7-25	4	C	F	A	0.167	0.533
316-4A	8-16	4	C	F	C	0.167	0.539
316-6	7-25	6	C	F	A	0.167	0.650
316-6A	8-16	6	C	F	C	0.167	0.492
318-3	8-9	3	C	F	A	0.162	0.508
318-4	8-9	4	C	F	A	0.172	0.488
318-6	8-9	6	C	F	A	0.166	0.545
322-T4L	9-27	4	L	T	C	0.250	0.348
322-T4L'	9-27	4	L	T	C	0.167	0.434
322-T4C	9-27	4	C	T	C	0.167	0.650
322-T4C'	9-27	4	C	T	C	0.167	0.423
307-4C	10-6	4	C	F	C	0.260	0.660
307-T4C	10-6	4	C	T	C	0.265	0.726

Sample	Date	Dimensions		Failure		Linear E		Failure Elon. (Mils)
		Film (Thk- Mils)	Comp (Thk- Mils)	Load (Lbs.)	Mode	ΔF (Lbs.)	ΔL (Mils)	
281-4	7-3	0.90	—	13.0	C	4.0	3.20	12.3
284-2	7-3	1.44	2.5	3.8	P	1.0	1.70	6.4
286-2	6-27	0.60	0.7	3.1	C	1.0	2.05	6.5
286-2	6-27	0.60	2.1	5.1	P	1.0	1.20	8.7
286-3	7-3	0.35	1.3	8.8	C	3.0	2.10	6.2
288-1	8-16	0.20	1.4	1.9	C	1.0	2.20	4.1
288-4	8-16	0.75	—	6.9	P	2.0	1.65	5.6
288-6	8-16	0.90	—	13.6	P	2.0	1.40	9.4
291-1	6-27	0.20	1.3	1.8	C	0.5	1.10	1.1
291-2	7-3	0.40	1.3	4.1	C	1.0	1.10	4.5
291-2'	7-3	0.40	1.3	1.1	C	1.0	1.25	2.9
291-4B	6-27	0.80	1.4	4.6	C	2.0	2.00	4.3
291-4	6-27	0.80	3.5	7.1	P	5.0	4.40	7.4
296-1	7-25	0.30	0.4	4.2	C	1.8	2.25	9.0
296-2	7-25	0.61	0.8	5.4	C	1.0	1.40	7.2
296-6	7-25	1.50	2.5	14.4	P	2.0	1.40	13.1
297-4	8-9	1.20	2.3	5.7	C	1.0	1.20	6.8
297-4A	8-15	1.20	2.4	8.0	C	2.0	2.00	8.1
304-4T	8-30	1.10	2.2	5.2	C	2.0	2.40	6.3
304-4	8-30	1.10	2.1	10.0	C	2.0	1.85	9.2
304-6T	8-30	1.30	3.3	11.6	C	2.0	1.70	10.2
305-2	7-14	0.40	1.7	1.5	P	0.8	1.50	3.0
305-2(TS)	7-14	0.25	2.0	4.0	P	1.0	1.75	7.3
305-6(TS)	7-14	1.30	3.5	10.0	C	2.0	1.85	8.7
308-4	8-21	1.10	5.6	11.0	P	5.0	3.85	6.9
308-4B	8-21	0.85	2.4	9.2	P	3.0	3.00	9.5
309-6T	8-30	2.10	2.3	9.0	P	2.0	2.30	7.1
309-6AT	8-30	0.60	2.0	3.4	C	1.0	1.30	4.6
313-T3C	9-27	0.60	3.4	1.4	C	1.0	1.00	1.7
313-T3C'	9-27	0.60	2.8	4.0	C	4.0	3.65	3.7
313-T4C'	9-27	0.90	2.3	10.4	C	4.0	2.60	7.0
313-T6C	9-27	1.10	2.9	4.4	C	4.4	3.35	3.4
313-T6C'	9-27	1.60	3.7	18.2	P	4.0	2.55	11.8
316-4	7-25	0.80	5.4	9.8	P	2.0	1.60	9.3
316-4A	8-16	0.60	5.4	10.6	P	2.0	1.70	9.7
316-6	7-25	1.45	1.9	10.6	P	2.0	1.65	10.5
316-6A	8-16	1.00	2.5	13.8	P	2.0	1.20	8.8
318-3	8-9	0.60	0.8	4.2	C	1.0	1.30	5.3
318-4	8-9	0.80	2.3	8.0	P	2.0	1.95	10.6
318-6	8-9	1.20	2.8	9.6	P	2.0	1.65	10.3
322-T4L	9-27	0.90	5.2	5.1	C	5.1	3.80	3.8
322-T4L'	9-27	0.90	4.0	3.9	P	2.0	1.50	2.8
322-T4C	9-27	1.10	4.5	5.4	P	4.0	3.50	5.3
322-T4C'	9-27	0.80	3.0	5.1	C	5.1	4.1	4.1
307-4C	10-6	0.90	3.8	11.7	C	2.0	1.80	10.6
307-T4C	10-6	0.90	3.2	11.1	P	2.0	1.80	5.0

Sample	Date	No. Piles	Orient.	Structure	Matrix	Specimen	
						Width Ins.	Gage Ins.
246-4C	10-6	4	C	F	C	0.163	0.234
246-T6C	10-6	6	C	T	C	0.168	0.749
251-T4C		4	C	T	C	0.254	0.646
251-T4C'		4	C	T	C	0.162	0.638
251-3C		3	C	F	C	0.164	0.56
251-3C'		3	C	F	C	0.163	0.645
293-3C		3	C	F	C	0.260	0.481
293-T4C		4	C	F	C	0.262	0.727
293-T3C		3	C	T	C	0.168	0.687
293-T3C'		3	C	T	C	0.165	0.777
194-T4C		4	C	T	C	0.261	0.555
194-T4C'		4	C	T	C	0.268	0.519
194-T3C		3	C	T	C	0.267	0.675

Sample	Date	Dimensions		Failure		Linear E		Failure Elon. (Mils)
		Film (Thk-Mils)	Comp (Thk-Mils)	Load (Lbs.)	Mode	ΔF (Lbs.)	ΔL (Mils)	
246-4C	10-6	0.8	4.7	4.80	C	2.0	1.40	4.0
246-T6C	10-6	1.5	5.4	6.50	P	2.0	1.80	6.4
251-T4C		0.75	2.6	12.20	C	2.0	1.75	10.9
251-T4C'		0.65	2.0	4.10	C	2.0	2.85	5.9
251-3C		0.5	3.0	3.90	C	2.0	2.70	5.2
251-3C'		0.45	4.1	3.45	C	2.0	3.40	6.0
293-3C		0.7	2.2	10.00	C	2.0	1.40	6.9
293-T4C		0.7	4.4	7.20	C	2.0	1.90	6.8
293-T3C		0.8	3.0	3.25	C	2.0	3.30	3.7
293-T3C'		0.8	2.6	5.80	C	2.0	2.45	7.0
194-T4C		1.2	3.0	5.55	C	2.0	1.60	4.7
194-T4C'		1.0	3.1	9.25	P	2.0	1.60	7.9
194-T3C		0.7	1.6	5.00	P	1.0	4.10	11.6

APPENDIX D
Composite Tensile Data Summary

COLUMN HEADINGS

1. Sample Number
2. Geometry
 - a. F—Full
 - b. S—Strip
 - c. T—Tile
 - d. P—Middle Plies Perforated
 - e. a to d followed by $1 \cdot 0^\circ$ Film Orientation. Others are 90° Orientation
3. Number of Plies
4. Matrix—See Appendix C for designations
5. Composite Quality—See Section 6.3.3 for Designations
6. Reinforcement Volume Fraction XR-%
7. Elastic Modulus—MS1
8. Tensile Strength—KS1
9. Strain at Failure—Mils per inch
10. Failure Mode
 - Progressive (P)
 - Catastrophic (C)
11. For Progressive Failure, number of peaks at less than (<) or greater than (>) failure strain
12. Notes
 - a—Non-Linear Curve
 - b—Small Peaks
 - c—Second peak almost same magnitude as failure load

TENSILE DATA SUMMARY

Sample	Geom	Plies	Mat	Qual	XR	E-MSI	TS-KSI	Failure Strain	C or P	Peaks < >	Notes
T6B	F	6	B	P	.500	2.80	17.7	9.36	P	1	a
T7	F	6	B	F	.200	1.96	14.7	8.00	C		
T8A	F	6	B	F	.457	—	20.0	—	—		
T9B	F	6	B	G	.433	4.93	17.6	5.30	C		a
T10A	F	6	B	G	.400	2.71	16.1	7.06	C		a
T11A	F	6	E	G	.529	2.05	11.6	7.40	P	1	a
T11B	F	6	E	G	.447	1.74	14.6	8.90	C		a
T11C	F-1	6	E	P	.357	2.68	13.2	5.54	P	2 2	
T12	F	6	D	G	.900	2.22	10.00	4.50	P	3	
T13B	F-1	6	D	G	.577	1.16	5.75	4.70	P	1	
T14A	F-1	6	D	F	.500	5.21	19.70	3.70	C		
T14B	F-1	6	D	F	.469	3.91	13.10	3.50	P	1	b
276-1	F	6	B	G	.789	12.10	133.00	4.53	P	1 1	
TM1	F	6	B		.367	0.70	6.46	10.50	C		
TM2	F	6	B		.360	0.41	4.56	9.76	P	1	b
TM3	F	6	B		.173	0.34	5.60	17.30	C		a
TM4	F	6	B		.529	1.04	11.10	8.68	C		
TM5	F	6	B		.391	1.12	10.60	7.68	C		
SL1	S	4	B	G	.370	1.48	19.60	13.60	C		a
SL2	S	4	B	F	.400	2.12	21.00	11.00	C		a
SL3	S	6	B	F	.576	2.89	16.10	9.50	C		a
SL4	S	6	B	G	.278	2.33	15.60	12.00	C		a
SL5	S	6	B	P	.263	1.35	11.10	8.50	P	1	b
SL6	S-1	6	D	E	.789	7.02	24.20	3.50	C		
SL7	S	6	E+D		—	2.31	6.88	3.00	C		a
13-4	F	4	A		.147	0.84	9.96	11.40	C		
13-6	F	6	A		.591	2.75	34.4	21.90	P	1 1	
20-4	T	4	A		.258	0.84	17.80	21.00	C		
20-4A	T	4	A		.160	0.61	4.97	8.23	C		
29-4	F	4	A		.250	1.38	14.60	15.60	P	2	
29-5	F	5	A		.393	1.57	14.70	9.71	C		
53-3	P	3	A		.176	1.57	5.46	5.97	P	1	
53-5	P	5	A		.380	1.56	10.50	6.83	C		
72-T3L'	T-1	3	C	G	.346	3.00	9.44	5.76	P	1	c
72-3C'	T	3	C	F	.162	0.70	8.24	11.80	C		
97-8	F	8	A		.591	2.21	16.30	14.80	P	1 1	
102-4A	F	4	A		.187	1.29	13.40	10.60	P	2	
102-6	F	6	A		.255	1.63	19.20	21.70	C		
105-4	F	4	A		.300	1.23	12.00	10.10	P	1 4	
105-4A	F	4	A		.533	1.86	29.20	7.52	P	2	
105-4B	T	4	A		.429	2.31	22.80	11.50	P	1	
111-2L	F-1	2	C	G	.308	1.34	3.62	2.70	C		
111-4L	F-1	4	C	E	.444	2.47	15.30	6.10	C		
111-4C	F	4	C	F	.556	2.56	17.80	16.96	P	1	
124-4	F	4	A		.367	1.72	20.00	16.30	P	1 1	
178-4C	F	4	C	P	.323	1.65	5.81	3.53	C		
178-6L	F-1	6	C	F	.438	1.89	10.90	5.75	P	3	

TENSILE DATA SUMMARY

Sample	Geom	Plies	Mat	Qual	XR	E-MS1	TS-MS1	Failure Strain	C or P	Peaks < >	Notes
179-4L	F-1	4	A	G	.917	3.71	20.10	6.04	P	1	b
179-6	F	6	A	G	.833	5.89	59.2	11.20	P	2 1	b
205-3	F	3	A		.391	1.66	14.70	8.39	P	1	
205-6	F	6	A		.444	1.92	23.60	13.00	P	2 2	b
242-1	F	1	A		.150	0.68	1.56	2.26	C		
242-1A	F	1	A		.250	0.978	7.68	5.78	C		
242-2	F	2	A		.239	2.03	1.67	2.04	C		
242-3	F	3	A		.400	1.60	8.98	4.20	C		a
242-4	F	4	A		.256	1.16	10.20	9.79	P	1	
248-6	F	6	A	G	.512	2.40	33.10	16.50	P	1	
248-6A	F	6	A		.667	2.50	34.90	19.10	P	1	
249-4	F	4	A		.235	1.24	10.40	8.21	C		
249-4A	F	4	A		.714	3.51	33.70	10.90	C		a
249-4B	T	4	A		.250	2.10	22.20	10.50	C		
252-1	F	1	A		.119	1.00	1.60	2.18	C		
252-1A	F	1	A		.192	1.78	1.72	1.58	C		
252-3	F	3	A		.615	2.75	15.40	5.60	C		
252-4	F	4	A		.667	2.87	41.10	14.00	C		
253-1	F	1	C		.094	0.81	6.53	7.87	C		
253-2	F	2	C		.100	0.61	4.60	7.41	P	1	
253-2A	F	2	C		.125	0.72	4.75	6.93	C		a
253-4	F	4	C		.294	3.05	25.20	8.67	C		
253-4A	F	4	C		.262	1.49	18.00	12.10	C		
266-4	F	4	A	E	.391	2.35	21.20	8.92	C		
266-5	F	5	A	G	.542	2.68	31.00	11.40	P	2	
266-5AL	F-1	5	A	F	.571	2.14	18.30	12.80	P	3 1	b
269-1	F	1	A		.150	0.88	5.99	6.83	C		
269-1A	F	1	A		.117	0.66	2.06	4.23	C		
269-2	F	2	A		.238	1.10	13.10	8.91	P	1	
269-3	F	3	A		.181	0.83	11.50	13.60	P	1	
269-4	F	4	A		.250	1.48	15.70	14.60	P	2 1	
271-1	F	1	A		.286	2.14	12.00	5.17	C		
274-1	F	1	A		.273	—	12.40	—	C		
274-1A	F	1	A		.188	—	5.25	—	C		
274-2	F	2	A		.833	—	38.00	—	P	1 1	b
275-4	T	4	A		.400	1.49	12.40	8.11	C		
275-5	F	5	A		.452	1.67	19.00	12.20	C		
278-2	F	2	A		.500	2.31	19.50	8.08	C		
278-2A	F	2	A		.147	0.81	4.82	6.96	P	1	
278-4	F	4	A		.476	1.87	15.60	10.50	P	3	
279-1	F	1	D		.188	0.38	4.25	11.30	C		a
279-4	F	4	D		.600	2.14	11.80	5.89	P	1	b
281-1	F	1	D		—	—	—	5.04	C		
281-2	F	2	D		.667	4.62	61.30	13.40	C		
281-2A	F	2	D		.155	0.81	7.86	7.75	C		
281-4	F	4	D		—	—	—	—	C		
284-2	F	2	D		.576	1.07	6.08	5.64	C	1	

TENSILE DATA SUMMARY

Sample	Geom	Plies	Mat	Qual	XR	E-MSI	TS-KSI	Failure Strain	C or P	Peaks < >	Notes
286-2	F	2	D		.860	1.54	17.70	11.80	C		
286-2	F	2	D		.286	.95	9.71	15.40	P	2	
286-3	F	3	D		.654	6.15	27.10	4.44	C		
288-1	F	1	C		.143	1.20	8.28	6.70	C		
288-4	F	4	C		—	—	—	7.28	P	1	
288-6	F	6	C		—	—	—	11.00	P	1	
291-1	F	1	D		.154	3.85	5.54	0.74	C		
291-2	F	2	D		.308	2.56	12.60	4.91	C		
291-2'	F	2	D		.308	2.20	3.38	3.57	C		
291-4B	T	4	D		.571	2.24	13.10	7.97	P	1	c
291-4	T	4	D		.229	3.57	8.11	3.40	C		
296-1		1	A		.750	4.63	62.90	12.90	C		
296-2		2	A		.763	4.34	40.40	8.81	C		
296-6		6	A		.600	3.29	34.50	14.90	P	1	
297-4	T	4	A		.522	1.02	9.35	9.13	C		
297-4A	T	4	A		.500	1.84	20.20	11.20	C		
304-4	F	4	A	E	.524	2.26	28.70	12.60	C		
304-4T	T	4	A	E	.500	2.13	14.50	6.87	C		
304-6T	T	6	A	F	.394	1.83	21.40	12.30	C		
305-2	F	2	A		.235	1.58	5.28	3.60	P	1	
305-2(TS)	T	2	A		.125	1.45	12.00	8.67	P	1	
305-6(TS)	T	6	A		.371	1.77	17.10	8.93	C		a
308-4	F	4	A		.196	0.58	11.60	15.00	P	1	b
308-4B	T	4	A		.354	1.66	23.50	14.80	P	2	b
309-6T	T	6	A	P	.913	1.89	22.80	7.46	P	2	a
309-6AT	T	6	A	P	.300	2.10	10.20	4.88	C		a
313-T3C	T	3	C	G	.176	0.69	2.47	4.52	C		a
313-T3C'	T	3	C	G	.214	1.34	8.55	6.39	C		
313-T4C'	T	4	C	F	.391	2.19	18.10	8.60	P	1	b
313-T6C	T	6	C	P	.379	1.90	8.98	4.73	C		
313-T6C'	T	6	C	F	.432	1.94	19.70	10.40	P	2	b
316-4	F	4	A	G	.148	0.99	10.90	13.80	P	3	
316-4A	F	4	C	H	.111	0.92	11.80	14.10	P	2	
316-6	F	6	A	G	.906	3.28	33.40	12.90	C		a
316-6A	F	6	C	H	.400	2.95	33.10	12.30	P	1 2	
318-3		3	A		.750	3.56	32.40	8.78	C		
318-4		4	A		.348	1.59	20.20	18.40	P	3	
318-6		6	A		.429	1.88	20.70	15.40	P	5	
322-T4L	T-1	4	C	F	.173	0.49	3.92	7.99	C		
322-T4L'	T-1	4	C	F	.225	1.18	5.84	4.65	P	1	
322-T4C	T	4	C	F	.244	1.28	7.24	9.72	P	1	
322-T4C'	T	4	C		.242	1.38	10.10	7.30	C		
307-4C	F	4	C	G	.237	0.95	11.80	12.50	C		
307-T4C	T	4	C	G	.281	1.22	13.10	3.83	P	2	
246-4C	F	4	C	G	.170	0.611	6.30	13.00	C		
246-T6C	T	6	C	E	.278	1.57	7.16	6.81	P	1	
251-T4C	T	4	C	G	.288	1.45	18.50	13.10	C		

TENSILE DATA SUMMARY

Sample	Geom	Plies	Mat	Qual	XR	E-MS1	TS-MS1	Failure Strain	C or P	Peaks < >	Notes
251-T4C'	T	4	C	F	.325	1.060	12.70	7.96	C		
251-3C	F	3	C	P	.167	0.989	7.93	7.89	C		
251-3C'	F	3	C	P	.110	0.643	5.15	8.23	C		
293-3C	F	3	C	G	.318	1.680	17.50	10.20	C		
293-4C	F	4	C	F	.159	0.841	6.25	7.37	C		
293-T3C	T	3	C	F	.267	0.940	6.45	4.44	C		
293-T3C'	T	3	C		.308	1.770	13.50	7.52	C		
194-T4C	T	4	C	G	.400	1.180	7.06	6.47	C		
194-T4C'	T	4	C	P	.323	1.040	11.10	11.70	P	1	
194-T3C	T	3	C	F	.438	0.405	11.70	15.70	P	1	

APPENDIX E
Composite Efficiency Data

COLUMN HEADINGS

1. Sample Number
2. Reinforcement Volume Fraction—%
3. Composite Tensile Strength—KS1
4. Composite Modulus—MS1
5. Film Tensile Strength—KS1
 - a. If no entry, value = 57.6 KS1
6. Film Modulus—MS1
 - a. If no entry, value = 7.1 MS1
7. Rule-of-mixtures tensile strength
8. Rule-of-mixtures modulus
9. Efficiency based on modulus
10. Efficiency based on tensile strength

COMPOSITE EFFICIENCY

Sample	XR-%	TS-KSI	E-MSI	TFS-KSI	EF-MSI	ROMTS	ROME	"(E)	"(TS)
T6B	50.0	17.70	2.80			31.1	3.82	73.3	56.9
T7	20.0	14.70	1.96			14.7	1.83	107.0	100.0
T8A	45.7	20.00	—			—	—	—	—
T9B	43.3	17.60	4.93			26.4	3.37	146.0	66.7
T10A	40.0	16.10	2.71			25.2	3.15	86.0	63.9
T11A	52.9	11.60	2.05			32.2	4.01	51.1	36.0
T11B	44.7	14.60	1.74			28.2	3.46	50.3	51.8
T11C	35.7	13.20	2.68			22.3	2.87	93.4	59.2
T12	90.0	10.00	2.22			52.1	2.87	34.3	19.2
T13B	57.5	5.75	1.16			34.2	4.33	26.8	16.8
T14A	50.0	19.70	5.21			29.7	3.82	136.0	66.3
T14B	46.9	13.10	3.91			28.0	3.61	108.0	46.8
TM6-1	78.9	133.00	12.10	168.0*	15.4*	168.0	15.40	168.0	1,540.0
TM1	36.7	6.45	0.70			24.5	2.93	23.9	26.4
TM2	36.0	4.56	0.41			23.9	2.89	14.2	19.1
TM3	17.3	5.60	0.34			17.1	1.65	20.6	32.7
TM4	52.9	11.10	1.04			32.5	4.01	25.9	32.2
TM5	39.1	10.60	1.12			24.9	3.09	36.2	42.6
SL1	37.0	19.60	1.48			25.6	2.95	50.2	76.7
SL2	40.0	21.00	2.12			26.3	3.15	67.3	79.8
SL3	57.6	16.10	2.89			35.2	4.32	70.4	45.7
SL4	27.8	15.60	2.33			20.3	2.34	99.6	76.8
SL5	26.3	11.10	1.35			18.3	2.24	60.3	60.7
SL6	78.9	24.20	7.02			45.8	5.73	123.0	52.8
SL7	—	6.88	2.31			—	—	—	—
13-4	14.7	9.96	0.84	116.0	15.20	21.9	2.66	31.6	45.5
13-6	59.1	34.40	2.75	116.0	15.20	73.1	9.19	29.9	47.1
20-4	25.8	17.80	0.84	70.5	9.09	26.0	2.72	30.9	68.5
20-4A	16.0	4.97	0.61	70.5	9.09	14.8	1.87	32.6	33.6
29-4	25.0	14.60	1.38			20.3	2.16	63.9	71.9
29-5	39.3	14.70	1.57			25.6	3.11	50.4	57.4
53-3	17.6	5.46	1.57			12.6	1.67	94.0	43.3
53-5	38.0	10.50	1.56			24.0	3.02	51.7	43.8
72-T3L'	34.6	9.44	2.00			21.8	2.79	71.7	43.3
72-3C'	16.2	8.24	0.70			14.3	1.57	44.6	57.6
97-8	59.1	16.30	2.21	77.5	4.94	48.8	3.12	70.8	33.4
102-4A	18.7	13.40	1.29	60.9	6.00	15.7	1.53	84.3	85.4
102-6	25.5	19.30	1.63	60.9	6.00	23.7	1.90	85.8	81.0
105-4	30.0	12.00	1.23			20.8	2.49	49.4	52.7
105-4A	53.3	29.20	1.86			32.5	4.30	46.2	89.8
105-4B	42.9	22.80	2.31			28.0	3.34	69.2	81.4
111-2L	30.8	3.62	1.34	83.0	9.19	26.5	3.18	42.1	13.7
111-4L	44.4	15.30	2.47	83.0	9.19	38.6	4.36	56.7	36.1
111-4C	55.6	17.50	2.56	83.0	9.19	47.7	5.33	48.0	39.6
124-4	36.7	20.00	1.72	57.5	10.70	26.3	4.24	40.6	76.0
178-4C	32.3	5.81	1.65			19.8	2.64	62.5	29.3

*Deduced from average single ply composite properties

COMPOSITE EFFICIENCY

Sample	XR-%	TS-KSI	E-MSI	TFS-KSI	EF-MSI	ROMTS	ROME	η (E)	η (TS)
178-6L	43.8	10.90	1.89	—	—	26.80	3.40	55.6	40.7
179-4L	91.7	20.10	3.71	133.0	19.70	125.00	18.10	20.5	16.1
179.6	93.3	59.20	5.89	133.0	19.70	112.00	16.50	35.7	52.9
205.3	39.1	14.70	1.66	70.4	12.90	30.10	5.35	31.0	48.8
205.6	44.4	23.60	1.92	70.4	12.90	40.60	6.01	31.9	58.1
242-1	15.0	1.56	0.68	40.8	3.59	7.08	2.05	33.2	22.0
242-1A	25.0	7.68	0.98	40.8	3.59	12.40	1.27	77.2	61.9
242-2	23.9	1.67	2.03	40.8	3.59	10.50	1.25	164.0	15.9
242-3	40.0	8.98	1.60	40.8	3.59	17.60	1.74	92.0	51.0
242-4	25.6	10.20	1.16	40.8	3.58	13.70	1.29	89.9	74.5
248-6	51.2	33.10	2.40	87.0	10.50	48.60	5.62	42.7	68.1
248-6A	66.7	34.90	2.50	87.0	10.50	61.20	7.17	34.9	57.0
249-4	23.5	10.40	1.24	95.2	16.80	25.50	4.21	29.5	40.8
249-4A	71.4	33.70	3.51	95.2	16.30	69.50	11.80	29.7	48.5
249-4B	25.8	22.20	2.10	95.2	16.30	28.50	4.58	45.9	77.9
252-1	11.9	1.60	1.00	—	5.94*	7.80	1.15	87.0	20.5
252-1A	19.2	1.72	1.78	—	5.94*	11.70	1.54	116.0	14.7
252-3	61.5	15.40	2.75	—	5.94*	36.50	3.85	71.4	42.2
252-4	66.7	41.10	2.87	—	5.94*	40.80	4.13	69.5	101.0
253-1	9.4	6.53	0.81	31.5*	3.80*	6.54	0.81	100.0	100.0
253-2	10.0	4.60	0.81	31.5*	3.80*	6.49	0.83	73.5	70.9
253-2A	12.5	4.75	0.72	31.5*	3.80*	6.97	0.91	78.9	68.1
253-4	29.4	25.20	3.05	31.5*	3.80*	12.30	1.47	207.0	205.0
253-4A	26.2	18.00	1.49	31.5*	3.80*	12.70	1.36	110.0	142.0
266-4C	39.1	21.20	2.34	—	—	25.20	3.09	76.1	84.1
266-5C	54.2	31.00	2.68	—	—	33.80	4.09	65.5	91.7
266-5AL	57.1	18.30	2.14	—	—	35.60	4.29	49.9	51.4
269-1	15.0	5.99	0.88	81.3	7.58	15.10	1.56	56.4	39.7
269-1A	11.7	2.06	0.66	81.3	7.58	11.40	1.33	49.6	18.1
269-2	23.8	13.10	1.10	81.3	7.58	22.70	2.19	50.2	57.7
269-3	18.1	11.50	0.83	81.3	7.58	20.30	1.78	46.6	56.7
269-4	25.0	15.70	1.48	81.3	7.58	25.80	2.27	65.2	60.8
271-1	28.6	12.00	2.14	—	—	18.30	2.40	89.2	65.6
274-1	27.3	12.40	—	—	—	21.50	2.31	—	57.7
274-1A	18.8	5.25	—	—	—	19.90	1.75	—	29.3
274-2	0.833	38.00	—	—	—	48.0**	6.02	—	79.2
275-4	40.0	12.40	1.49	—	—	25.50	3.15	47.3	48.6
272-5	45.2	19.00	1.67	—	—	29.40	3.50	47.7	64.6
278-2	50.0	19.50	2.31	43.6	4.16	23.80	2.33	99.1	81.9
278-2A	14.7	4.82	0.81	43.6	4.16	9.78	1.04	77.9	49.3
278-4	47.6	15.60	1.87	43.6	4.16	23.60	2.25	83.1	66.1
279-1	18.8	4.25	0.38	37.9	3.66	11.70	1.09	34.9	36.3
279-4	60.0	11.80	2.14	37.9	3.66	23.90	2.40	89.2	49.3
281-2	66.7	61.30	4.62	—	—	40.70	4.92	93.9	151.0

*Deduced from average single ply composite properties

**Matrix contribution excluded

COMPOSITE EFFICIENCY

Sample	XR-%	TS-KSI	E-MSI	TFS-KSI	EF-MSI	ROMTS	ROME	η (E)	η (TS)
281-2A	15.5	7.86	0.81	—	—	12.7	1.53	52.9	61.9
284-2	57.6	6.08	1.07	67.5	5.16	40.1	3.18	33.6	15.2
286-2	86.0	17.70	1.54	35.1	3.67	50.3	3.23	47.7	35.2
286-2	28.6	9.71	0.95	35.1	3.67	15.5	1.41	67.4	62.6
286-3	65.4	27.10	6.15	35.1	3.67	23.7	2.57	239.0	114.0
288-1	14.3	8.28	1.20	—	—	11.1	1.45	82.8	74.6
291-1	15.4	5.54	3.85	52.7	5.57	8.42	1.28	301.0	65.8
291-2	30.8	12.60	2.56	52.7	5.57	17.9	2.06	124.0	70.4
291-2A	30.8	3.38	2.20	52.7	5.57	17.5	2.06	164.0	19.3
291-4	57.1	13.10	2.24	52.7	5.57	30.8	3.39	66.1	42.5
291-4B	22.9	8.11	3.57	52.7	5.57	15.2	1.66	215.0	53.4
296-1	75.0	62.90	4.63	81.7*	6.01*	62.9	4.63	100.0	100.0
296-2	76.3	40.40	4.34	81.7*	6.01*	49.0	4.70	92.3	82.4
296-6	60.0	34.50	3.29	81.7*	6.01*	40.7	3.81	86.4	84.8
297-4	52.2	9.35	1.02	72.5	6.35	40.0	3.55	28.7	23.4
297-4A	50.0	20.20	1.84	72.5	6.35	39.1	3.43	53.6	51.7
304-4	52.4	28.70	2.26	109.0	13.50	60.1	7.31	30.9	47.8
304-4T	50.0	14.50	2.13	109.0	13.50	56.3	7.00	30.4	25.8
304-6T	39.4	21.40	1.83	109.0	13.50	46.7	5.62	32.6	45.8
305-2	23.5	5.28	1.58	80.3	9.72	20.2	2.67	59.2	26.5
305-2(TS)	12.5	12.00	1.45	80.3	9.72	13.8	1.65	87.9	21.6
305-6(TS)	37.1	17.1	1.77	80.3	9.72	32.7	3.92	45.2	52.3
308-4	19.6	11.60	0.58	—	—	17.3	1.80	32.2	67.1
308-4B	35.4	23.50	1.66	—	—	30.4	2.85	58.2	77.3
309-6T	91.3	22.80	1.89	97.3	12.6	89.2	11.50	16.4	25.6
309-6AT	30.0	10.20	2.19	97.3	12.6	30.9	4.13	53.0	33.0
313-T3C	17.6	2.47	0.69	—	—	12.0	1.67	41.3	20.6
313-T3C'	21.4	8.55	1.34	—	—	14.8	1.92	69.8	57.8
313-T4C'	39.1	18.10	2.19	—	—	25.1	3.09	70.9	72.1
313-T6C	37.9	8.98	1.90	—	—	24.5	3.01	63.1	36.7
313-T6'	43.2	19.70	1.94	—	—	27.8	3.36	57.7	70.9
316-4	14.8	10.90	0.99	—	—	14.4	1.48	66.9	75.7
316-4A	11.1	11.80	0.92	—	—	12.7	1.24	174.2	92.9
316-6	90.6	33.40	3.28	—	—	52.8	6.51	50.4	63.3
316-6A	40.0	33.10	2.95	—	—	26.8	3.15	193.7	124.0
318-3	75.0	32.40	3.56	66.4	4.77	50.3	3.70	96.2	64.4
318-4	34.8	20.20	1.59	66.4	4.77	29.1	1.99	79.9	69.4
318-6	42.9	20.70	1.88	66.4	4.77	32.9	2.33	80.7	62.9
322-T4L	17.3	3.92	0.49	—	—	13.3	1.65	29.7	29.5
322-T4L'	22.5	5.84	1.18	—	—	14.8	1.99	59.3	39.5
322-T4C	24.4	7.24	1.28	—	—	17.7	2.12	60.4	40.9
322-T4C'	24.2	10.10	1.38	—	—	16.7	2.10	65.7	60.5
307-4C	23.7	11.80	0.95	—	—	18.4	2.07	45.9	64.1
307-T4C	28.1	13.10	1.22	—	—	17.6	2.36	51.7	74.4
246-4C	17.0	6.30	0.61	—	—	15.2	1.63	37.5	41.4
246-T6C	27.8	7.16	1.57	—	—	18.5	2.34	67.1	38.7

*Deduced from average single ply composite properties

COMPOSITE EFFICIENCY

Sample	XR-%	TS-KS1	E-MS1	TFS-KS1	EF-MS1	ROMTS	ROME	$\eta(E)$	$\eta(TS)$
251-T4C	28.8	18.50	1.450			21.3	2.41	60.2	86.9
251-T4C'	32.5	12.70	1.060			21.4	2.65	40.0	59.3
251-3C	16.7	7.93	0.989			12.9	1.61	61.4	61.5
251-3C'	11.0	5.16	0.643			10.0	1.23	52.3	51.6
293-3C	31.8	17.50	1.680			21.8	2.61	64.4	80.3
293-T4C	15.9	6.25	0.841			12.3	1.69	49.8	50.8
293-T3C	26.7	6.45	0.940			17.0	2.27	41.4	37.9
293-T3C'	30.8	13.50	1.770			20.3	2.54	69.7	66.5
194-T4C	40.0	7.06	1.180			25.0	3.15	37.5	28.2
194-T4C'	32.3	11.10	1.040			22.6	2.64	39.4	49.1
194-T3C	43.8	11.70	0.405			29.6	3.40	11.9	39.5

APPENDIX F

Two-Material Beam Analysis

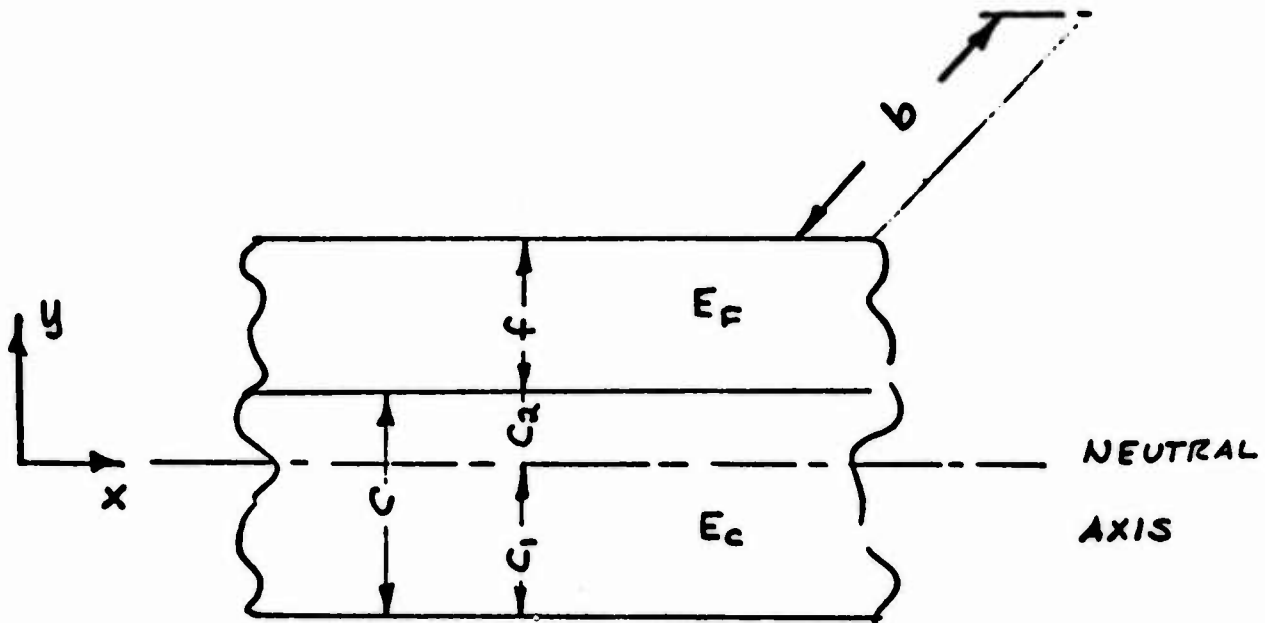

The neutral axis is located from $\int E y dA = 0$; $dA = b dy$

$$E_c b \int_{-c_1}^{c_2} y dy + E_F b \int_{c_2}^{c_2+f} y dy = 0$$

$$\frac{b}{2} \{ E_c (c_2^2 - c_1^2) + E_F [(c_2 + f)^2 - c_2^2] \} = 0$$

$$E_c \underbrace{(c_2 - c_1)}_{-(c - 2c_2)} \overbrace{(c_2 + c_1)}^c + E_F [c_2^2 + 2c_2 f + f^2 - c_2^2] = 0$$

$$E_c \cdot c \cdot (c - 2c_2) = E_F f (f + 2c_2)$$

Solving for C_2 ,

$$C_2 = \frac{1}{2} \frac{E_c C^2 - E_F f^2}{E_c C + E_F f}$$

Letting $a = E_F f / E_c C$

$$C_2 = \frac{C}{2} \left[1 - \frac{a f}{1 + a} \right] \quad (1)$$

Since $C_1 = C - C_2$,

$$C_1 = \frac{C}{2} \left[1 + \frac{a}{1+a} \left(1 + \frac{f}{C} \right) \right] \quad (2)$$

The flexural rigidity is given by,

$$\begin{aligned} D &= \int E y^2 dA = b \int E y^2 dy \\ &= b \left\{ E_c \int_{-C_1}^{C_2} y^2 dy + E_F \int_{C_2}^{C_2+f} y^2 dy \right\} \\ &= \frac{b}{3} \left\{ E_c (C_2^3 + C_1^3) + E_F \left[(C_2 + f)^3 - C_2^3 \right] \right\} \quad (3) \end{aligned}$$

Assuming $\frac{f}{C} \ll 1$ as in the present case

results in simplifications of EQS (1) - (3)

$$\text{Thus, } \left. \begin{aligned} \frac{C_1}{C/2} &\sim 1 + \frac{a}{1+a} \\ \frac{C_2}{C/2} &\sim 1 - \frac{a}{1+a} \end{aligned} \right\} \begin{aligned} a \rightarrow 0, & C_1 \rightarrow C_2 \rightarrow \frac{C}{2} \\ a \rightarrow \infty, & C_1 \rightarrow C, C_2 \rightarrow 0 \end{aligned}$$

Substituting into equation (3) results in,

$$D = \frac{1}{3} E_c b C^3 \left\{ \left(\frac{C_2}{C}\right)^3 + \left(\frac{C_1}{C}\right)^3 + \frac{E_F}{E_c} \left[\left(\frac{C_2 + f}{C}\right)^3 - \left(\frac{C_2}{C}\right)^3 \right] \right\}$$

Expanding,

$$\left(\frac{C_2 + f}{C}\right)^3 - \left(\frac{C_2}{C}\right)^3 = \cancel{\left(\frac{C_2}{C}\right)^3} + 3 \frac{f}{C} \left(\frac{C_2}{C}\right)^2 + 3 \left(\frac{f}{C}\right)^2 \frac{C_2}{C}$$

$$+ \left(\frac{f}{C}\right)^3 - \cancel{\left(\frac{C_2}{C}\right)^3}$$

$$\approx 3 \left(\frac{C_2}{C}\right)^2 \frac{f}{C} \quad \text{for } \frac{f}{C} \ll 1$$

$$= \frac{3}{4} \frac{f}{C} (1/1+a)^2$$

$$\begin{aligned} \left(\frac{C_2}{C}\right)^3 + \left(\frac{C_1}{C}\right)^3 &= \frac{1}{8} \left\{ 1 - 3 \frac{a}{1+a} + 3 \left(\frac{a}{1+a}\right)^2 - \left(\frac{a}{1+a}\right)^3 \right. \\ &\quad \left. + 1 + 3 \frac{a}{1+a} + 3 \left(\frac{a}{1+a}\right)^2 + \left(\frac{a}{1+a}\right)^3 \right\} \\ &= \frac{1}{4} \left[1 + 3 \left(\frac{a}{1+a}\right)^2 \right] \end{aligned}$$

Finally,

$$D = \frac{1}{3} E_c b C^3 \left\{ \left[\frac{1}{4} + \frac{3}{4} \left(\frac{a}{1+A} \right)^2 \right] + \frac{3}{4} \frac{E_F}{E_c} \frac{f}{C} \left(\frac{1}{1+a} \right)^2 \right\}$$

$$= \frac{1}{12} E_c b C^3 \{ (1+a)^2 + 3a^2 + 3a \} \div (1+a)^2$$

$$= \frac{1}{12} E_c b C^3 \{ (1+a)^2 + 3a(1+a) \} \div (1+a)^2$$

$$\text{or } \frac{D}{\frac{1}{12} E_c b C^3} = \frac{1+4a}{1+a}$$

$$\text{Letting } \beta = D / \frac{1}{12} E_c b C^3, \quad \beta = \frac{1+4a}{1+a}$$

$$\text{As } a \rightarrow 0, \quad \beta \rightarrow 1$$

$$a \rightarrow \infty, \quad \beta \rightarrow 4$$

$$\text{Solving for } a, \quad a = \frac{\beta - 1}{4 - \beta}$$

APPENDIX G

Raw Flexure Data

For symbols refer to Appendix F.

RAW FLEXURE TEST DATA

Sample	1	T5D	T8D	T5	T8B	T6	T-10
No. Plies	6.0	6.0	6.0	6.0	6.0	6.0	6.0
Matrix	—	—	—	—	—	—	—
Film Thk. - Mils	—	1.8	1.6	1.8	1.6	1.3	1.2
f - Mils	1.8	2.1	2.8	2.0	2.8	2.0	3.0
XR	—	0.857	0.571	0.900	0.571	0.650	0.400
C - Mils	60.4	77.0	59.0	62.7	62.8	61.9	62.2
b - Inches	0.485	0.5	0.5	0.482	0.510	0.462	0.501
l - Inches	1.0	1.0	1.0	1.0	1.0	1.0	1.0
ΔF_c - Lbs.	1.3	3.1	1.4	1.6	1.7	1.4	1.4
ΔL_c - Mils	6.0	6.0	6.0	6.0	6.0	6.0	6.0
E_c - MSI	0.507	0.566	0.568	0.561	0.561	0.532	0.484
ΔF - Lbs.	2.8	4.95	2.7	2.1	2.9	2.5	2.5
ΔL - Mils	6.0	6.0	6.0	6.0	6.0	6.0	6.0
D	9.72	17.2	9.38	7.29	10.1	8.68	8.68
B	2.154	1.596	1.929	1.313	1.706	1.786	1.786
a	0.625	0.248	0.449	0.116	0.308	0.355	0.355
E_f - MSI	10.6	5.15	5.37	2.04	3.88	5.85	3.56
Failure Load Lbs.	5.3	11.6	5.9	7.8	11.0	7.4	9.2
t - Mils/In.	4.24	6.66	4.86	8.68	8.94	6.80	8.65
Strength - KSI	44.9	34.3	26.1	17.7	34.7	39.8	30.8

APPENDIX H

Flexure Data Summary

COLUMN HEADINGS

1. Sample Number
2. Reinforcement Fraction (XR)
3. Failure Strain—Mils per inch
4. Rule of Mixture Modulus (ROME)
5. Rule of Mixture Tensile Strength (ROMTS)
6. Modulus (E)—MSI
7. Tensile Strength (TS)—KSI
8. Composite Efficiency Modulus
9. Composite Efficiency Tensile Strength

FLEXURAL DATA SUMMARY

Sample	XR	Fail Str. Mils./In.	ROME	ROMTS	E MSI	TS KSI	η (E)*	η (TS)*
1	—	4.24	—	—	10.60	44.9	—	—
T5	0.900	8.68	6.44	52.3	2.04	17.7	31.7	33.8
T5D	0.857	6.66	6.16	49.8	5.15	34.3	83.6	68.9
T6	0.650	6.80	4.76	38.6	5.85	39.8	123.0	103.0
T8B	0.571	8.94	4.27	34.8	3.88	34.7	90.9	99.7
T8D	0.571	4.86	4.27	33.9	5.37	26.1	126.0	77.0
T10	0.400	8.65	3.14	25.6	3.56	30.8	113.0	120.0

*Efficiencies based on average film properties.