

AD-762 548

AN EVALUATION OF ALTERNATIVE MOBILE
FIELD KITCHEN CONCEPTS

John C. Perry, et al

Army Natick Laboratories
Natick, Massachusetts

February 1972

DISTRIBUTED BY:

NTIS

National Technical Information Service
U. S. DEPARTMENT OF COMMERCE
5285 Port Royal Road, Springfield Va. 22151

DISCLAIMER NOTICE

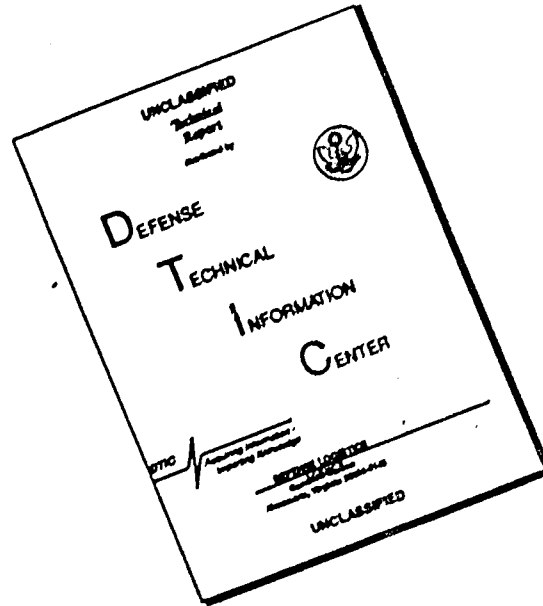

THIS DOCUMENT IS BEST QUALITY AVAILABLE. THE COPY FURNISHED TO DTIC CONTAINED A SIGNIFICANT NUMBER OF PAGES WHICH DO NOT REPRODUCE LEGIBLY.

AD 762548

AD

TECHNICAL REPORT

73-44-6P

**AN EVALUATION OF ALTERNATIVE
MOBILE FIELD KITCHEN CONCEPTS**

by

J. C. Perry

G.D. Bell, and

CPT H M. Toczyłowski

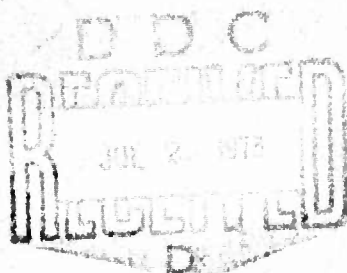

Approved for public release,
distribution unlimited.

February 1972

UNITED STATES ARMY
NATIONAL LABORATORIES
Natick, Massachusetts 01760



General Equipment & Packaging Laboratory

63 4

Approved for public release;
distribution unlimited.

AD _____

TECHNICAL REPORT

73-44-GP

AN EVALUATION OF
ALTERNATIVE MOBILE FIELD KITCHEN CONCEPTS

by

John C. Perry

Gordon D. Bell, and

CPT Henry M. Toczylowski

Project Reference:
1J664713D548

February 1972

Food Systems Equipment Division

General Equipment & Packaging Laboratory

U. S. ARMY NATICK LABORATORIES

Natick, Massachusetts 01760

FOREWORD

This Food Systems Equipment Division's effort was conducted as Task 22 under Project 1J664713D548 Mobile Kitchen. The objective was to evaluate six alternative mobile field kitchen concepts

The authors wish to express their appreciation to all those who participated in the study. A special acknowledgment is accorded to Dr. Carolyn Benschel, Pioneering Research Laboratory, Mr. Jack Gilmette, Quality Assurance and Engineering Office and MSG David Dexter, Food Service Equipment and Evaluation Team, General Equipment and Packaging Laboratory.

TABLE OF CONTENTS

	<u>Page</u>
Foreword	ii
List of Appendices	iv
List of Illustrations	v
Abstract	vi
Background	1
Design Parameters and Assumptions	2
Analytical Procedure	3
Analysis	5
<u>Phase I:</u>	
Menu	5
Production Quantities and Manpower	5
Equipment Selection	5
Storage Requirements	6
Disposables	7
Shelters and Vehicles	8
Ancillary Equipment	10
<u>Phase II:</u>	
Concept Development	10
Final Configuration	11
<u>Phase III:</u>	
Concept Analysis	12
Summary	17
Conclusion	19
Recommendations	20
Appendices	21

LIST OF APPENDICES

	<u>PAGE</u>
A. Letter, AMXRE-GFS, USANLABS, 27 December 71, Subject: Field Kitchen System	21
B. Letter, CDCMS-0, USACDC, 27 January 72, Subject: Field Kitchen System	24
C. Fort Lee Questionnaire Summary	25
D. Daily a-la-Carte Breakfast Menu	32
E. Supper/Dinner Menu Pattern	33
F. Shelter, and Vehicle (Trailer) Analysis	34
G. S-280 Shelter Configuration	43
H. M-116, 3/4-ton Trailer Configuration	44
I. M-103, 1-1/2-ton Trailer Configuration	45
J. M-35, 2-1/2-ton Truck Configuration	46
K. Production Cost Estimates	47

LIST OF ILLUSTRATIONS

	<u>PAGE</u>
Figure 1. Flow Chart of Methodology for Field Kitchen Evaluation Study	4
Figure 2. M116 Chassis, Trailer, 3/4 ton, 2 wheel	37
Figure 3. M103 Chassis, Trailer, 1-1/2 ton, 2 wheel	38
Figure 4. M794 Trailer, Flatbed, 4 ton, 4 wheel	39
Figure 5. M390 Chassis, Trailer, 2 ton, 2 wheel	40
Figure 6. M200 Chassis Trailer, 2-1/2 ton, 2 wheel.	41
Figure 7. M35 Truck, Cargo, 2-1/2 ton, 6 x 6	42
Figure 8. S280 Shelter Configuration	43
Figure 9. M116 3/4-ton Trailer Configuration.	44
Figure 10. M103 1-1/2-ton Trailer Configuration.	45
Figure 11. M35 2-1/2-ton Truck Configuration	46
Table I. Equipment Selected for Cooking Operation.	6
Table II. Storage Requirements Summary	6
Table III. Cost and Storage of Disposable Mess Gear.	7
Table IV. Advantages and Disadvantages of using Disposable Mess Gear	8
Table V. Factor Analysis of Field Kitchen System Concepts	15
Table VI. Estimated Production Cost Schedule	16
Table VII. Shelter Analysis	35
Table VIII. Vehicle Analysis	36

ABSTRACT

Six field feeding concepts were studied and evaluated for potential use as a mobile field kitchen for the U. S. Army.

A thorough analysis of the major design consideration and parameters was conducted. They are:

<u>Factors</u>	<u>Definition</u>
1. Storage	Ability to store all food, equipment and ancillary gear.
2. Transportability	Ease of assembly/disassembly and movement between locations.
3. Cook Enroute	Ability to prepare food while in transit.
4. Shelter	Adequate protection from the elements.
5. Safety	Ability of system to function without fear of injury to personnel.
6. Anthropometrics	Man's physical characteristics as related to his working environment.
7. Sanitation	Free from agents injurious to health.
8. Environment	Ability to control and maintain workable atmospheric conditions.
9. Workspace	Sufficient worktable space for food preparation.
10. Functional	Configuration conducive to efficient work flow.

It is concluded that two of the six concepts evaluated be considered. They are a self-contained soft shelter kitchen mounted on a standard 1 1/2-ton trailer chassis and a self-contained soft shelter kitchen mounted on 2 1/2-ton wheel cargo truck vehicle.

AN EVALUATION OF ALTERNATIVE MOBILE FIELD KITCHEN CONCEPTS

BACKGROUND

The high degree of mobility and wide dispersal of troop units characteristic of the modern Army make it essential to use fast, easily operated, mobile feeding equipment. The feeding concepts of the Army provide for the feeding of the fresh A-Ration to troops in the field whenever possible. At present, the size of the basic unit that must be supported is the company consisting of a troop strength of 200 \pm 50 men.

The present system, the M-1959 Field Kitchen that is being utilized in the field, has undergone little change since the development of the M-1937 Field Kitchen. The M-59 range outfit is a value-engineered version of the earlier model. The system consists of a range cabinet with a burner unit, pots, utensils, roast pan, and a baking rack set. This equipment is normally used in the field with the kitchen tent. A primary limitation of this system is its relatively low degree of mobility as represented by the time and effort required to set up and strike the tentage and to load the kitchen equipment on and off transport vehicles.

To overcome these limitations in the field feeding of a company-sized unit, the concept of a mobile kitchen was developed. A QMR was written and the design of the Modular Mobile Kitchen formulated. As a parallel project the SPEED Kitchen was also designed to fulfill the same requirement. Both of these units were self-contained in a hard shelter with the main differences in energy sources being that the Modular Mobile Kitchen was liquid-fuel-fired and the SPEED Kitchen was operated by both electric and electronic means.

To determine the military potential of the feeding systems, a test was designed to compare the standard M-59 Field Kitchen, the Modular Mobile Kitchen and the SPEED Kitchen. Following the review of the results of the test, a decision was made to hold up all further developmental work on either of these two systems pending the results of a system analysis study on field feeding to be performed by the Operations Research/Systems Analysis Office of the U. S. Army Natick Laboratories (NIABS).

However, as a result of a meeting held on 9-10 December 1971 at NIABS between U.S. Army Combat Developments Command (CDC), U.S. Army Materiel Command (AMC), and NIABS, it was determined that immediate development of a field kitchen that would be mobile, yet of simple design and relatively inexpensive, would be desirable. NIABS was assigned the responsibility of conducting an evaluation of several different configurations to determine the best approach to the design of such a Field Kitchen System. The various design parameters to be followed in the study were discussed and determined at that time.

DESIGN PARAMETERS AND ASSUMPTIONS

By a determination of the 9-10 December meeting, five configurations were to be evaluated. This was confirmed by letter from NLABS to CDC dated 27 December 1971 (Appendix A). One additional configuration was added to the study as a result of a letter from CDC to NLABS dated 27 January 1972 (Appendix B). The configurations are as follows:

1. A rigid shelter mounted on a 2 1/2-ton wheeled vehicle.
2. A rigid shelter mounted on a standard 1 1/2-ton trailer chassis.
3. A rigid shelter mounted on a standard dual axle trailer chassis.
4. A self-contained soft shelter kitchen mounted on a standard 3/4-ton trailer chassis.
5. A self-contained soft shelter kitchen mounted on a standard 1 1/2-ton trailer chassis.
6. A self-contained soft shelter kitchen mounted on a 2 1/2-ton wheeled vehicle chassis.

The following assumptions were adopted for this study:

1. Feeding level: 200 \pm 50 personnel.
2. Type of food: A-Ration.
3. Storage: Five consecutive meals.
4. Bread, fuel, and water: Same methods of handling as in the present system.

Bread: Issue item.

Fuel: Five-gallon cans.

Water: Standard water trailer.

5. Equipment: Maximum use of standard TO&E equipment. M-59 range cabinet and the M-2 burner unit must be used; all must be detachable.
6. Transport: Essential: (1) Highway. (2) Cross country.
Desirable: Helicopter transportable.

7. Small Unit Feeding: Use of insulated containers.
8. Prime Mover: 2 1/2-ton cargo vehicle.

ANALYTICAL PROCEDURE

The evaluation was focused on the study of six different field kitchen systems as defined by CDC. Once the parameters and assumptions were stated and the problem area defined, an objective approach to evaluating the equipment systems had to be developed. The researcher's plan was divided into three phases. Phase I was concerned with the basic subsystems that comprise a field feeding kitchen. The major subsystems that were researched were: (1) menu, (2) shelters/vehicles, and (3) ancillary equipment. Each of these areas will be discussed in the analysis section. Phase II of the study was concerned with attempting to "idealize" each of the six field kitchen concepts that were defined earlier in the report. From this process, final configurations were developed for each concept.

An evaluation of each of the six systems was conducted in Phase III of the study. The three major areas of concentration were: (1) advantages/disadvantages of each system, (2) production cost of each system, and (3) R&D program schedule. At the same time a trip was made to the U.S. Army Quartermaster School at Fort Lee, Virginia in order to solicit the comments and opinions of experienced mess personnel with regard to field feeding systems. A summary of the results of the questionnaire are in Appendix C. From the results of the evaluation of the major areas of concentration and the data generated by the Fort Lee Study, an NLABS recommendation was formulated.

Figure 1 depicts each of the three phases and how they interface with one another.

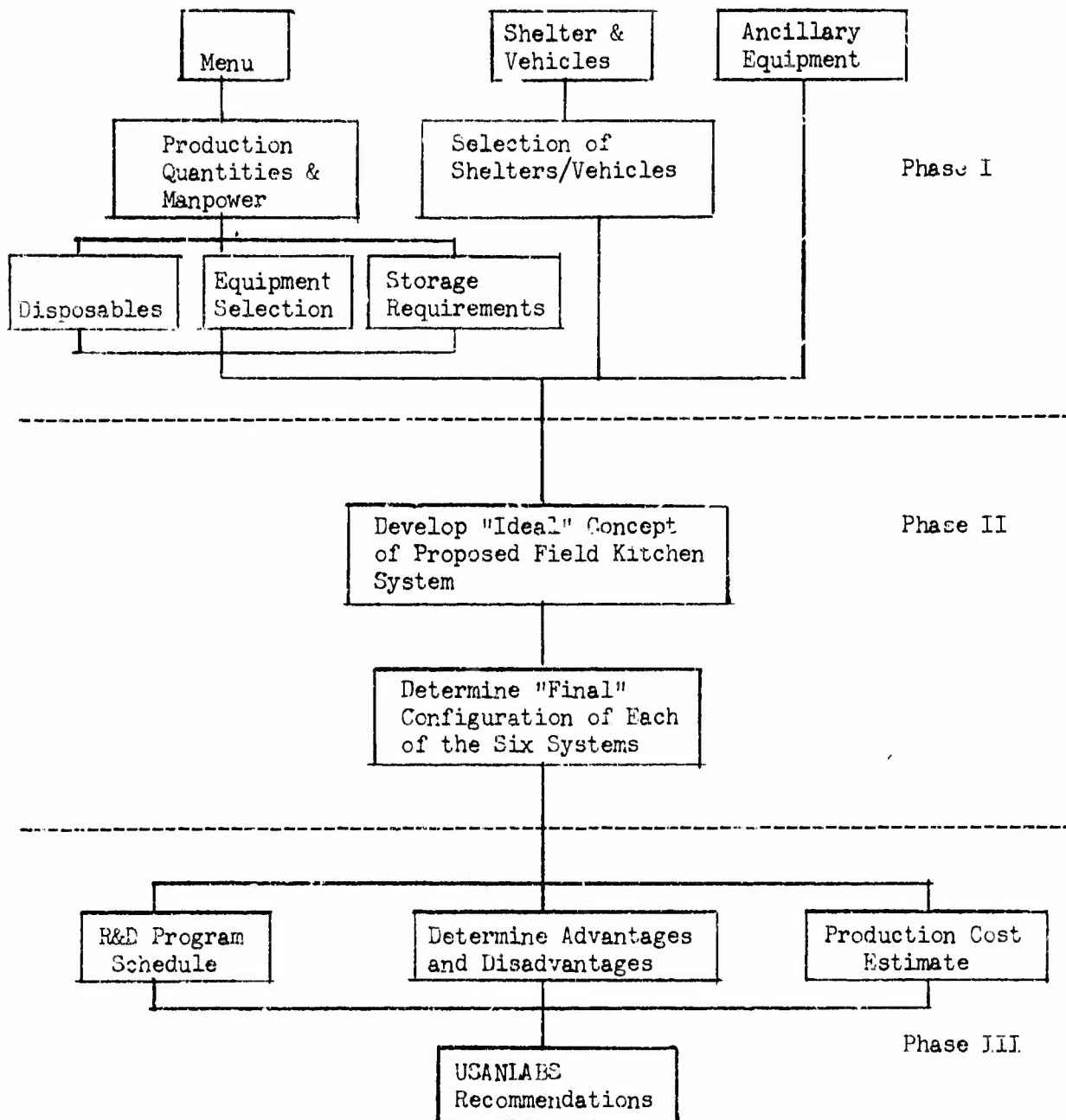

Figure 1. Flow Chart of Methodology for Field Kitchen Evaluation Study

ANALYSIS

Phase I

1. Menu

The A-Ration was utilized for determining the production quantities. The SB 10-260 Master Menu¹ was used as a basis for all calculations. In order to determine the maximum food quantities that would have to be stored, the five most difficult to prepare consecutive meals (dinner/supper/breakfast/dinner/supper) were selected. The menus were selected on the basis of their demand on equipment capacities and storage cube.

2. Production Quantities and Manpower

The Military Food Service Equipment and Evaluation Team of NLABS was consulted in order to determine the most difficult to prepare menus for the study. The daily a-la-carte breakfast menu pattern as listed on page 4 of the Master Menu was utilized. Appendix D contains the necessary data on the quantities of food needed to prepare the breakfast meal for 250 men. Because the Master Menu is based on a 42-day cycle, many different combinations of food items occur. In order to determine the total amount of food that was to be prepared at each meal, each major cooking operation was identified. The quantities of food required were then calculated. A summary of the operations and quantities needed to prepare food for 250 men for the dinner or supper meal can be found in Appendix E. The manpower requirement for this system consists of two cooks per shift. This was determined through open discussion with Military mess personnel at Fort Lee, Virginia.

3. Equipment Selection

As defined in the design parameters, the M-2 burner unit and the M-59 range outfit were required to be utilized in the design of the new kitchen system. Based on the quantity of food to be prepared (Appendices D and E), the following table shows the equipment selected for the cooking operation:

¹DA Supply Bulletin SB 10-260 Master Menu for Jan 72.

Table I. Equipment Selected for Cooking Operation.

<u>QUANTITY</u>	<u>ITEM</u>	<u>JUSTIFICATION</u>
1	Grill, 2' x 3' with 2 M-2 burner units	Grilling of eggs, hot cakes, French toast, hamburgs, steak, etc.
2	Cooking racks, 2' x 2' each with 1 M-2 burner unit	Heating of liquids for beverages, vegetables, sauces, soups, deep fried foods, etc.
2	M-59 Range Outfit	Baking and roasting of food products.
2	Jugs, Insulated, 5-gallon	Holding and dispensing of beverages.
8	Food Container, Insulated	Holding and transporting of prepared food items.

Items such as utensils, pots, pans, and small equipment will be specified when an actual system is agreed upon and field tested. The above items are those that are required for the preparation of food in all the six kitchen concepts.

4. Storage Requirements

There is a Research and Development study at Natick Laboratories which is attempting to determine the net volume of perishable and non-perishable storage space required for food items issued in the Master Menu. Preliminary results of this study indicate that for 250 men, a five-meal storage capacity of 72.46 cubic feet is required for perishables and 52.12 cubic feet for nonperishables. The addition of disposable mess gear adds an additional 11.43 cubic feet. The following table summarizes the storage requirements:

Table II. Storage Requirements Summary.

<u>ITEM</u>	<u>NET CUBIC FEET</u>
Perishables	72.46
Nonperishables	52.12
Disposables	11.43

The perishables will be adequately stored in five-cubic-foot insulated containers or in a mechanically operated refrigerator. Mechanical refrigeration is definitely required if the issue of perishable food is on a 2-2-3-day delivery cycle. As an interim recommendation, the 70-cubic foot mechanical refrigeration box should be utilized on the 2-2-3-day delivery cycle. The disposable mess gear and the nonperishable food items will be stored in both the trailer and truck depending upon the configuration selected. Ice will be stored in an insulated chest under the worktable in each kitchen system except for the 3/4-ton trailer concept. In this concept the ice will be stored in the truck.

5. Disposables

The use of disposable mess gear in lieu of using plastic trays or metal mess gear was investigated as requested by CDC.

According to the results of the Fort Jackson, South Carolina test, "Military Potential Test of Food Service Systems",² the use of disposable mess gear reduced the potable water requirements and showed a significant savings in KP manpower reduction. The total KP manhours were reduced from 18.98 hours per meal using plastic trays to 10.57 hours per meal using disposables. Theoretically, this results in a 44.31% decrease in KP manhours per meal. Also a savings of 810 gallons of water with the use of disposables was realized. This was based on the amount of water for 250 men for three meals.

Following is a chart of the cost of disposable mess gear for one man per year and the net volume required to store the gear:

Table III. Cost and Storage Data of Disposable Mess Gear.

<u>QUANTITY</u>	<u>ITEM</u>	<u>COST PER MAN PER YEAR (EST)</u>	<u>VOLUME PER MAN PER YEAR</u>
1	Tray, 5-Compartment	\$24.09	4.93 ft ³
1.5	Cup, 6-oz.	31.47	2.47
2	Napkin	1.62	2.63
1	Tableware Set	27.38	3.07
		<u>\$66.56</u>	<u>13.10</u>

²Burt et al, Military Potential Test of Food Service Systems, US Army GETA, USATECOM Proj No. 7-ES-765-000-001, Oct 71.

From this the required storage cube for 250 men for the disposable mess gear for five meals would be 11.43 net cubic feet. Storage requirements are calculated from the space required to store supplies for the next day's meal and the two meals remaining once the supplies are picked up.

Following is a list of advantages and disadvantages of using disposable mess gear:

Table IV. Advantages and Disadvantages of using Disposable Mess Gear.

<u>ADVANTAGES</u>	<u>DISADVANTAGES</u>
1. KP Reduction	1. Possible Storage Problem
2. Less water required	2. How and where to dispose
3. Cleaning supplies reduced	3. Supply problem
4. Fewer immersion heaters required	
5. Improved sanitation	

If disposable mess gear were utilized, fewer immersion heaters and 32-gallon cans for the mess kit laundry would have to be issued to wash and rinse the pots and pans.

6. Shelters and Vehicles

The guidelines previously defined specified that a rigid shelter and standard Army vehicles (specifically a 3/4-ton trailer, a 1 1/2-ton trailer dual-axle trailer, and 2 1/2-ton truck) would be utilized to develop the field feeding concept.

In order to choose those components that would provide the desired characteristics for the proposed field feeding system, a study was performed encompassing all shelters in the Department of Defense inventory and all standard Army trailers. Utilizing the "Reference Manual for Shelters"³ Natick Laboratories, January 1972, which describes all types of standard or experimental shelters and by working with the Army Tank Automotive Command with reference to trailers, the desirable characteristics were identified and the determination as to which items would most adequately adapt to the field kitchen application was made.

³Reference Manual on Shelters, USANLABS, Jan '72.

All of the shelters in the Department of Defense inventory were considered. However, because most shelters are special purpose, consequently, of high cost, several were disqualified on that basis. The physical configuration of many did not adapt readily to the truck-mounted or trailer-mounted concepts and were subsequently disqualified. The three best choices were considered to be three rigid non-expandable, standard shelters: the S-280 Shelter, electrical equipment; the S-141 Shelter, electrical equipment; and the US Marine Corps Shelter, electrical equipment. In comparing the S-280 and the S-141 shelters, it was determined that the difference in weight was 100 pounds and the difference in price \$152.00, with the S-280 shelter being the heavier and more expensive of the two. However, the S-280 shelter is slightly larger in configuration (length, 4", width, 6", height, 1"). The differences in the overall dimensions are considered significant in the already compact shelter. As a result, the decision between the two was made in favor of the S-280. The overall dimensions of the S-280 and the Marine Corps shelters are length 146", width 87" and height 83". The differences in the cost and weight of the shelters are \$1,000.00 and 4,840 pounds, respectively, with the Marine Corps shelter being the cheaper and heavier of the two. The final choice between the two was based on the 4,840-pound weight differential. The weight of the Marine Corps shelter exceeds the cross-country capability of the 1 1/2-ton trailer. This excessive weight would increase those problems in ground handling and helicopter transportability. Consequently, the S-280 was the final selection.

The choice between trailers was somewhat simplified as the M-116, 3/4-ton and the M-103A3, 1 1/2-ton trailer chassis are those standard Army trailer chassis from which all but certain special purpose 3/4-ton and 1 1/2-ton trailers are derived. Both the M-116 and M-103A3 chassis will accept the field kitchen trailer beds with minimum modifications. Based on this capability, their load-bearing capacity, and their relatively low cost, they are considered to be the best possible choices.

As most dual axle trailers are primarily special purpose in nature, the M-794, 4-ton, 4-wheel flat-bed trailer was considered to be that trailer which would most readily adapt to the field-feeding shelter-mounted trailer concept due to its physical configuration.

The truck-mounted concept was also considered utilizing as a prime mover the standard Army M-35, 2 1/2-ton truck.

The shelter and vehicles which were selected as the best choices were the Shelter, electrical equipment S-280, the chassis trailer (Military design), M-116, 3/4-ton, 2-wheel; the chassis trailer (Military design), M-103A3, 1 1/2-ton, 2-wheel; Trailer, Flat bed (Military design), M-794, 4-ton, 4-wheel; and the M-35, Truck, Cargo, 2 1/2-ton, 6 x 6 (See Appendix F for physical configuration and characteristic data for each item).

7. Ancillary Equipment

The equipment analysis indicated several items are required to support the operation of a field kitchen which are ancillary to the kitchen proper. These include:

- a. Bag, water, sterilizing
- b. Can, Ash & Garbage
- c. Heater, Immersion
- d. Tableware Outfit, Field
- e. Trailer, Tank, Water, 400-Gallon

Phase II

1. Concept Development

The following list of factors must be considered in the design of the optimum field feeding system:

Table V. Factors to be Considered.

<u>Factors</u>	<u>Definition</u>
1. Storage	Ability to store all food, equipment and ancillary gear.
2. Transportability	Ease of assembly/disassembly and movement between locations.
3. Cook Enroute	Ability to prepare food while in transit.
4. Shelter	Adequate protection from the elements.
5. Safety	Ability of system to function without fear of injury to personnel.
6. Anthropometrics	Man's physical characteristics as related to his working environment.
7. Sanitation	Free from agents injurious to health.
8. Environment	Ability to control and maintain workable atmospheric conditions.
9. Workspace	Sufficient work table space for food preparation.
10. Functional	Configuration conducive to efficient work flow.

2. Final Configurations

CONCEPT I

Standard S-280 Shelter mounted on the bed of a standard M-35 2 1/2-ton truck. For internal configuration, see Appendix G. The food will be prepared while working inside the shelter. Food will be served across the grill (through windows cut in the side of the shelter in front of the grill and cooking rack) to the troops who will be moving across step-up ramp elevated to the height of the bed of the 2 1/2-ton truck. All subsistence will be stored in the accompanying 1 1/2-ton trailer. Ancillary equipment will be stored and transported in the shelter. A jacking system will be incorporated to allow for the loading and off-loading of the shelter on the bed of the truck without assistance of materiel handling equipment.

CONCEPT II

Standard S-280 Shelter mounted on a standard 1 1/2-ton trailer. For internal configuration see Appendix G. The concept of operation is similar to Concept I. A step-up ramp would be assembled at the height of the bed of the trailer. Subsistence will be stored in the 2 1/2-ton truck along with the ancillary equipment.

CONCEPT III

Standard S-280 Shelter mounted on a standard dual axle M-794 trailer. For internal configuration see Appendix G. The concept of operation is identical to that of Concept II.

CONCEPT IV

A standard 3/4-ton trailer with a self-contained soft shelter for protection from the elements. For configuration see Appendix H. Food will be prepared by personnel working around the trailer on elevated platforms at the grill, cook rack, and oven areas. Food will be served directly from the trailer. All subsistence will be stored on the 2 1/2-ton truck with the ancillary gear.

CONCEPT V

A standard 1 1/2-ton trailer with a self-contained soft shelter for protection from the elements. For configuration see Appendix I. Food will be prepared by mess personnel working on the trailer platform. Troops will be served across the grill as they move across a step-up ramp elevated to the height of the trailer bed. All subsistence will be stored in the 2 1/2-ton truck with the ancillary gear.

CONCEPT VI

A standard M-35, 2 1/2-ton truck with a three-part sectionalized, helicopter transportable platform with kitchen equipment mounted on each of the three platform sections. For internal configuration see Appendix J. The use of extensions in the bows will increase the height of the canvas cover. The food will be prepared while working in the rear of the truck and served across the grill to the troops as they move along a step-up ramp elevated to the height of the bed of the truck. Subsistence will be stored in both the truck and the accompanying 1 1/2-ton trailer.

Phase III

Concept Analysis

CONCEPT I

The S-280 shelter mounted on the M-35, 2 1/2-ton truck has several advantages and disadvantages. The primary advantage of the hard shelter concept over the soft shelter configurations is that the hard shelter does not necessitate any time-consuming steps in the assembly and disassembly of the overhead cover. Also, as a self-contained field kitchen in an enclosed shelter, the problems involved in sanitation are greatly reduced.

The ability to cook enroute between locations while the shelter is mounted in the rear of the M-35, 2 1/2-ton truck appears to be a definite desirable advantage of the truck-mounted shelter over the trailer-mounted concepts. In reality, the ability to cook enroute exists. However, the M-2 burner unit is by nature unstable and by compounding the instability of the burner by placing it (while in transit) within a closed container with limited exit routes constitutes an extremely dangerous situation which renders the practice almost infeasible. The ability of the shelter when mounted on the bed of the 2 1/2-ton truck to be moved quickly upon alert notification is an obvious advantage. However, in the event of vehicular breakdown the effort that must be expended to remove the kitchen shelter from the vehicle is extensive. To facilitate the loading and off-loading of the shelter, a jacking system must be developed or some other ancillary method must be utilized.

Additional disadvantages are those problems related to space and storage. Under the present M-59 Field Kitchen Concept, the 2 1/2-ton truck would maintain the bulk of the storage while in transit. In the truck-mounted shelter configuration, the storage capacity is considerably reduced. Also, the 2 1/2-ton vehicle is not able to be utilized for obtaining rations from the ration supply point or water point. (For a 250-man company for mess facilities alone, 1167 gallons of water are needed per day.) The inability of the mess section to use their vehicle for water and ration runs renders the section dependent upon other sections of the unit. Consequently, it greatly reduces efficiency and the ability of the mess section to perform.

Another problem which must be considered is that of ventilation. As there will be an excessive amount of heat generated within the shelter (up to 360,000 Btu's) the need for mechanical ventilation exists. There are three main problems associated with the problem of ventilation, those being: (1) the shelter must be modified to accept ventilation equipment, (2) with the already cramped internal configuration, internal ventilation ducts would further reduce the available work space inside the shelter, (3) MIL Standard generator must be added to the system to provide power to operate the ventilating system. Additionally, one complete side of the shelter must be modified to provide windows through which the troops may be served. This, again, would incur an additional cost in adapting the shelter to field-feeding.

CONCEPTS II & III

The 1 1/2-ton trailer is a smaller, lighter, less durable trailer than the dual axle trailer. However, the concept of operation and the advantages and disadvantages of each trailer-mounted hard shelter system are relatively the same.

The main difference in the trailer-mounted and the truck-mounted shelter concepts is that in the trailer-mounted configuration, the 2 1/2-ton truck is not committed to housing a kitchen. Consequently, it is able to obtain rations and water from the ration supply point or the water point as is done in the present M-59 field kitchen system.

CONCEPT IV

The 3/4-ton trailer concept has several advantages. Safety is perhaps the main advantage this system has over all of the other systems that were considered. This configuration is the only one in which the system is positioned at the ground level with free access from all sides. With no confining walls or barriers, the system lends itself to quick exit routes in case of fire or other mishap. Also, storage may be divided between the 2 1/2-ton truck and the trailer-mounted kitchen in a manner very similar to the method that is used in the present system. The 2 1/2-ton mess truck, therefore, is free to obtain rations and water. Additionally, ventilation should be as good as atmospheric conditions allow.

The main disadvantage in the system is one of sanitation. With all work being performed on the ground, the situation exists where it would be nearly impossible to keep personnel, food, or equipment entirely clean. Also, as with all the trailer concepts considered, the ability to cook enroute does not exist.

A cover must be erected over the trailer which constitutes a disadvantage when compared to a hard type shelter. Helicopter lift of either trailer concept (3/4-ton, 1 1/2-ton) provides the capability of being entirely independent of the 2 1/2-ton truck as a prime mover.

CONCEPT V

The 1 1/2-ton trailer concept will adequately meet those factors considered to be desirable in a field feeding system with the exception of the ability to cook enroute.

The main advantage that the 1 1/2-ton trailer concept has over the 3/4-ton trailer concept is sanitation. As the 1 1/2-ton trailer concept is basically a kitchen mounted on an elevated platform, those sanitation problems encountered with working with food at ground level are minimized. Additionally, this system can be considered to be one of the safer systems that was developed as there are no confining walls which would prevent a quick exit. Other advantages and disadvantages pertaining to a soft shelter trailer concept correlate directly with those of CONCEPT IV.

CONCEPT VI

The main advantage the 2 1/2-ton kitchen truck system has over the others considered is flexibility. The system is mounted on a lightweight platform which may be separated into three separate sections. This capability makes it a relatively simple task to load and off-load the vehicle. This would increase the mess section's ability to make the system ready for transport in a relatively short period of time. Also, the system would not permanently commit a vehicle as the platform could be off-loaded and assembled on the ground with canvas cover. A further advantage of this system is its ability to be helicopter-lifted from one location to another. Rations, water, canvas cover, and ancillary gear could be secured to the platform and helicopter-lifted to any location without requiring further commitment of a 2 1/2-ton truck or trailer.

The 2 1/2-ton truck concept will adequately meet all the factors that were identified as desirable in a field-feeding system. The kitchen truck concept is not new in field-feeding. Kitchen trucks have been constructed since World War II for feeding troops in tactical situations. TM-10-405⁴ describes one method (utilizing standard TO&E equipment) of constructing a mobile kitchen truck. There are, however, several differences between the kitchen truck in TM-10-405 and the proposed truck mounted kitchen system. An attempt was made to provide the cooks in the field with those standard items that for many years were fabricated out of necessity. Items such as cooking racks and an efficient grill are examples of this. By providing field personnel with these items as standard equipment, the need to construct them in some makeshift fashion out of whatever materials are available is eliminated.

Safety, again, is a major advantage in this system as the ability of a man to escape from a fire or other mishap is not prevented by a rigid wall structure, as the soft shelter can be rolled up on the sides when the

⁴Technical Manual, TM-10-405, Army Mess Operations, Hq DA, Aug 67.

kitchen is in operation. However, although personnel are not stringently confined within an enclosed area as in the shelter concept, it is considered unsafe from a safety standpoint to cook enroute.

As a disadvantage when the truck is committed to housing the platform and kitchen components, the storage capacity would be reduced, and the truck would not be able to obtain rations and water.

The following table depicts the ability of each of the six systems evaluated to meet the desirable characteristics:

Table VI. Factor Analysis of Field Kitchen System Concepts.

FACTORS											% Factors Met
	Storage	Transportability	Cook Enroute	Shelter	Safety	Anthropometrics	Sanitation	Environment	Workspace	Functional	
CONCEPTS	1	2	3	4	5	6	7	8	9	10	
I	0	x	x	x	0	0	x	0	0	0	40
II	x	x	0	x	0	0	x	0	0	0	10
III	x	x	0	x	0	0	x	0	0	0	40
IV	x	x	0	x	x	x	0	x	0	0	60
V	x	x	0	x	x	x	x	x	x	x	90
VI	x	x	x	x	x	x	x	x	x	x	100

x = Yes, meets factors

0 = No, does not meet factors

The final step in the evaluation was to perform a cost analysis of the six concepts in the study. A tabulation of the estimated costs is shown in Table VII. (See Appendix K for a detailed cost breakdown).

Table VII. Estimated Production Cost Schedule.

	KITCHEN*	TRUCK	TRAILER	TOTAL
CONCEPT I	16,090.00	9,380.00	947.00	26,417.00
CONCEPT II	12,790.00	9,380.00	947.00	23,117.00
CONCEPT III	12,790.00	9,380.00	7,000.00	29,170.00
CONCEPT IV	4,308.00	9,380.00	760.00	14,448.00
CONCEPT V	4,308.00	9,380.00	947.00	14,635.00
CONCEPT VI	4,077.00	9,380.00	947.00	14,404.00

*Estimates include the costs of preparation and storage equipment, shelter or tentage, ramps, platforms, and ventilation equipment, where applicable. However, not included are the costs of standard TO&E equipment presently available to troop units such as the M-59 range outfits, insulated food containers and mess kit laundry gear. Where additional TO&E equipment is required the costs have been included.

Cost estimates were then compared with the factor analysis shown in Table V to determine the best cost effective concept.

SUMMARY

Six field feeding concepts were developed based on the following areas:

1. Menu: The A-Ration was utilized for determining the production quantities. The SB 10-260 Master Menu was used as a basis for all calculations.

2. Production Quantities and Manpower Requirements: The daily a-la-carte breakfast menu pattern of the Master Menu was utilized. The total amount of food that must be prepared at each meal was calculated for each major cooking operation. The manpower requirement for this system is two cooks per shift.

3. Storage: Results indicate that for 250 men for a five-meal storage capacity 72.46 net cubic feet are required for perishables and 52.12 net cubic feet are required for nonperishables. The addition of disposable mess gear adds an additional 11.43 net cubic feet to the nonperishable storage. The perishables will be adequately stored in five-cubic-foot insulated containers or in a mechanically operated refrigerator. However, mechanical refrigeration is definitely required if the issue of perishable food is on a 2-2-3-day delivery cycle.

4. Disposable mess gear utilization: If disposable mess gear were utilized, fewer immersion heaters or cans for the mess kit laundry would have to be issued to wash and rinse the pots and pans.

5. Shelters and Vehicles: The shelters and vehicles which were selected as the best choices were the Shelter, electrical equipment S-280; the chassis trailer (Military design), M-116, 3/4-ton, 2-wheel; the chassis trailer (Military design), M103A3, 1 1/2-ton, 2-wheel; Trailer, Flat bed (Military design), M-794, 4-ton, 4-wheel; and the M-35, Truck, Cargo, 2 1/2-ton, 6 x 6.

6. Ancillary Equipment: The equipment analysis indicated several items are required to support the operation of a field kitchen which are ancillary to kitchen proper. These include: (1) Bag, water, sterilizing, (2) Can, Ash and Garbage, (3) Heater, Immersion, (4) Tableware Outfit, Field, and (5) Trailer, Tank, Water, 400-Gallon.

From an analysis of the data generated in the preceding areas, the design requirements were identified. From this an optimum system capable of meeting all of the physical characteristics of a field feeding system could be developed. Certain key factors were recognized as those desirable characteristics in the development of a field feeding system. They are:

<u>Factors</u>	<u>Definition</u>
1. Storage	Ability to store all food, equipment, and ancillary gear.
2. Transportability	Ease of assembly/disassembly and movement between locations.
3. Cook Enroute	Ability to prepare food while in transit.
4. Shelter	Adequate protection from the elements.
5. Safety	Ability of system to function without fear of injury to personnel.
6. Anthropometrics	Man's physical characteristics as related to his working environment.
7. Sanitation	Free from agents injurious to health.
8. Environment	Ability to control and maintain workable atmospheric conditions.
9. Workspace	Sufficient work tables space for food preparation.
10. Functional	Configuration conducive to efficient work-flow.

Based on these factors, the six concepts were evaluated. A list of the advantages and disadvantages of each system was developed along with a production cost estimate.

From the factor analysis and the estimated production cost, it has been demonstrated that CONCEPT VI meets the greatest number of desirable characteristics for the optimum field feeding system. However, it was recognized that CONCEPT V was able to meet all the requirements with the exception of the ability to cook enroute.

The low ratings on the factor analysis evaluation and the relatively high cost of CONCEPTS I through III eliminate them as feasible solutions. The disadvantages inherent in CONCEPT IV render it an undesirable solution when compared with the relative advantage of CONCEPTS V and VI.

CONCLUSION

Only CONCEPTS V and VI meet sufficient criteria to warrant consideration.

However, tactical considerations are required to determine the final selection. Trade-off analysis should be utilized for the following criteria:

1. Vehicle availability for ration and water support.
2. Requirements for cooking enroute as defined in TM 10-405.
3. Degree of rough terrain capability required for a mobile kitchen to include a decision to determine if a track vehicle can act as a prime mover for a 1 1/2-ton kitchen trailer over rough terrain.

RECOMMENDATIONS

The Combat Developments Command evaluate the two technically adequate concepts (Concepts V & VI) to determine the one that best meets the tactical requirements of the Field Army.

The QMR for a Mobile Field Kitchen be modified in accordance with the concept selected and that an appropriate requirements document be issued.

Development of the selected concept be initiated in FY72 utilizing currently available funds which must be obligated by 30 June 1972. Program funding will be required through completion of development in the amount of \$155,000.00. The following R&D schedule applies to either concept selected:

FIELD KITCHEN CONCEPT

<u>DEVELOPMENT STAGES</u>	<u>TIME</u>	<u>SIX PROTOTYPES COST (X1000)</u>
Phase I ED (Design)	4 months	\$ 75*
Phase II ED (Prototype)	9 months	130*
Phase III ET/ST	9 months	150
Phase IV TC	<u>3 months</u>	<u>5</u>
TOTAL	25 months	\$ 360

<u>FISCAL YEAR BUDGET</u>	<u>COST (X1000)</u>
FY72	\$ 205*
FY73	105
FY74	<u>50</u>
	\$ 360

*FY72 funds currently available

APPENDICES

	<u>Page</u>
A. Letter, AMXRE-GFS, USANLABS, 27 December 1971, Subject: Field Kitchen System	21
B. Letter, CDCMS-U, USACDC, 27 January 1972, Subject: Field Kitchen System	24
C. Fort Lee Questionnaire Summary	25
D. Daily a-la-Carce Breakfast Menu	32
E. Supper/Dinner Menu Pattern	33
F. Shelter, and Vehicle (Trailer) Analysis	34
G. S-280 Shelter Configuration	43
H. M-116, 3/4-ton Trailer Configuration	44
I. M-103, 1-1/2-ton Trailer Configuration	45
J. M-35, 2-1/2-ton Truck Configuration	46
K. Production Cost Estimates	47



APPENDIX A

DEPARTMENT OF THE ARMY
U S ARMY NATICK LABORATORIES
NATICK, MASSACHUSETTS 01760

IN REPLY REFER TO

C O P Y

AMXRE-GFS

27 December 1971

SUBJECT: Field Kitchen System

THRU: Commanding General
US Army Materiel Command
ATTN: AMCRD-JI
Washington, D. C. 20315

TO: Commanding General
US Army Combat Developments Command
ATTN: CDCMS-O
Ft. Belvoir, Virginia 22060

1. These Laboratories have been undertaking development of a modular mobile field kitchen in response to an approved DA Qualitative Materiel Requirement. It was recommended by CDC during this development that a field experiment be conducted to provide a comparison of the SPEED, Mobile and M-59 Kitchens. AMC concurred in this recommendation and a 17-week evaluation was undertaken. The experiment was completed in June 1971 and a report of findings was submitted by USATECOM in late November 1971. It was determined by all concerned that continuing development of either the SPEED or Modular Mobile Kitchen was not warranted at this time.

2. A meeting was held at these Laboratories on 9-10 December 1971 to discuss field kitchens. As a result of these discussions, these Laboratories agreed to perform an Equipment Evaluation Study for the purpose of determining the proper course of development for an interim Field Kitchen.

C O P Y

AMXRE-GFS

27 December 1971

SUBJECT: Field Kitchen System

3. There are five specific configurations to be evaluated, as follows:
 - a. A rigid shelter mounted on a 2 1/2-ton wheeled vehicle.
 - b. A rigid shelter mounted on a standard dual wheel trailer chassis.
 - c. A rigid shelter mounted on a standard 1 1/2-ton trailer chassis.
 - d. A self-contained soft shelter kitchen mounted on a standard 3/4-ton trailer chassis.
 - e. A self-contained soft shelter kitchen mounted on a standard 1 1/2-ton trailer chassis.
4. The parameters for this study include the following:
 - a. Feeding Level - 200 \pm 50 personnel.
 - b. Type of Food - A-Ration.
 - c. Food Preparation - Two dinners, two suppers and one breakfast (selected from Master Menu and considered to be most difficult to prepare).
 - d. Storage - Capable of storing five meals.
 - e. Bread - Issued item, no preparation.
 - f. Equipment - To be standard to maximum practical extent, which will include the Range Cabinet, M-59 and Burner Unit, M-2.
 - g. Water - Water trailer towed by company supply vehicle.
 - h. Utensils - Disposables and nondisposables to be studied.
 - i. Helicopter transport to be considered.
 - j. Fuel - 5-gallon cans.

C O P Y

AMXRE-GFS
SUBJECT: Field Kitchen System

27 December 1971

5. The study will include the advantages and disadvantages of the various configurations as well as cost information and an NLABS recommendation for the final configuration to be pursued with the development schedule through type classification. The system will include the packaging and transport of all auxiliary equipment required for operation. The schedule for completion of this study is 15 February 1972.
6. Upon approval of this study an operation "breadboard" model will be fabricated by these laboratories for use as a concept model which will be available for demonstrations as required. This model will not be a prototype capable of withstanding formal field testing. A trailer-mounted kitchen utilizing a soft shelter could be made available approximately two months following study approval. A model utilizing a rigid shelter would require additional time.
7. Field kitchen systems used by fourteen foreign nations have been studied by these Laboratories. Of these, eleven utilize a trailer concept using a soft or semi-soft shelter for mobility with only two using the 2 1/2-ton cargo vehicle with a similar arrangement as that shown in TM-10-405. The basic method of cooking by foreign countries is boiling or stewing in contrast to the larger amount of frying, baking and roasting common to the US Military ration. Direct adoption of the foreign equipment is not feasible due to the varied equipment requirements that exist as a result of this difference in ration and other factors such as "buy American" and use of non-standard trailers and equipment which would cause serious supply and maintenance problems and be more costly in production.
8. The QMR for the modular mobile kitchen will be used as the basis for the current effort. It was agreed at the 10 December meeting that NLABS would recommend to CDC the kitchen concept which shows the most promise. A meeting will then be scheduled at which time CDC, as agreed, would approve the design (either as presented or with modifications offered by CDC) and issue a change to the requirement to properly reflect the new kitchen parameters.

FOR THE COMMANDER:

CF:
OCDR
DCSLOG
ACSPOR

/s/
JAMES H. FLANAGAN
Deputy Scientific Director
for Engineering

APPENDIX B



DEPARTMENT OF THE ARMY
HEADQUARTERS LTC Brumit/gls/35-41458
UNITED STATES ARMY COMBAT DEVELOPMENTS COMMAND
FORT BELVOIR, VIRGINIA 22060

CDCMS-0

27 JAN 1972

SUBJECT: Field Kitchen System (USACDC ACN 6214)

Commanding Officer
US Army Natick Laboratories
ATTN: AMRE-GFS
Natick, Massachusetts 01760

1. Reference, letter, AMRE-GFS, HQ USANLABS, 27 Dec 71, subject as above.
2. This command has reviewed referenced letter and agrees with the Equipment Evaluation Study, subject to the previously agreed clarification of paragraphs 5 and 8 concerning completeness of the study and milestones for CDC review.
3. Request a sixth specific configuration be added to the study or at least considered in sufficient detail to insure a total appraisal of the possible technical approaches. The sixth approach would be a self-contained soft shelter kitchen mounted on a 2 1/2 ton wheeled vehicle.
4. Attached at Inclosure 1 is a basic design approach for such a kitchen. It was shown in the September 1971 issue of Army Reservist Magazine.

FOR THE COMMANDER:

1 Incl
as

CF:
CG, USACDCPALSG, ATTN: PLSC-M
CG, USAMC, ATTN: AMCRD-JI
CO, USACDCSUA

Robert L. Cronin
ROBERT L. CRONIN
2LT, AGC
Asst AG

APPENDIX C

FORT LEE QUESTIONNAIRE SUMMARY

A lack of feedback pertaining to problem areas in field feeding exists between the "man in the field" and the personnel who develop their equipment. The purpose of this study was (1) to establish a form of communication between the ultimate user and the designer, (2) to solicit new ideas from experienced mess personnel, and (3) to identify those problem areas that are inherent in the present field feeding system.

A questionnaire was developed to gather information and attitudes on various phases of field feeding: (1) rations, (2) equipment, (3) operations, (4) maintenance and safety, and (5) future concepts. The questionnaire was administered to experienced mess personnel at the US Army Quartermaster School at Fort Lee, Virginia and at the US Army Natick Laboratories, Natick, Massachusetts.

This survey reflects over 800 man-years of military experience with an average experience level of 16.52 years. The general consensus of the comments of those mess personnel responding to questionnaire are as follows:

Rations. The preparation and serving of a CONUS type ration under field conditions was not considered feasible by 70% of the personnel. Extensive problems were encountered due to the lack of refrigeration. A trailer-mounted refrigeration system was considered highly desirable.

Equipment. The current equipment was considered adequate by 91% of the personnel, however, there seems to be definite need for an independent grill and an improvement in the design of the M-2 burner. Storage space was felt to be a major deficiency in the present system. A self-contained, standardized mobile field unit is needed to increase the transportability of the kitchen system. The existing M-1948 tent was found to be very time-consuming and awkward to erect and strike.

Operations. The current field feeding system was considered to be adequate by 81% of the personnel. The current system was considered to be mobile by 77% of the respondents; however, the time required to assemble and disassemble the mess equipment was considered too excessive by 82% of mess personnel. The ability to prepare food enroute was an extremely desirable capability.

Maintenance and Safety. Excessive time was required to perform maintenance on the M-2 Burner Unit. The pressure release valve, air gauge, and preheater were the prime problem areas of the burner. There seems to be a definite safety hazard inherent in the M-2 burner unit, specifically with the pressure build-up and the air gauge.

Future Concepts. The most important considerations in designing a field feeding system were (1) mobility, (2) menu, (3) serving time, (4) sanitation, and (5) burner units. The use of convenience foods will not eliminate the need for the skilled cook and baker.

It was concluded that the comments and responses by experienced mess personnel be further reviewed for an eventual improvement in the present field feeding system.

DEPARTMENT OF THE ARMY
U. S. Army Natick Laboratories
Food Systems Equipment Division
General Equipment & Packaging Laboratory
Natick, Massachusetts 01760

FIELD FEEDING QUESTIONNAIRE

RANK _____ DATE _____
PRESENT DUTY ASSIGNMENT _____ YEARS IN SERVICE _____
FIELD FEEDING EXPERIENCE (In Months)
SOUTH EAST ASIA _____ WW II _____
GERMANY _____ OTHER _____
KOREA _____

All of the following questions relate to the present field feeding system as described in TM 10-405 Army Mess Operations. The response to these questions will be utilized to improve the design of the field feeding system. Please feel free to "Tell it like it is." Thank you for your participation in this survey.

1. Is the field feeding system currently in use adequate for field food preparation and feeding?
2. In your opinion, what is the feasibility of preparing and serving a CONUS type ration under tactical conditions?

3. How much time should be allotted to serve food to a 200-man company under tactical conditions?

4. How could a typical serving line be modified to increase its speed or efficiency?

5. What has been your experience with regard to the ration issue cycle (in days) in a tactical environment? What problems are involved in storage?

6. Is the field feeding system currently in use mobile? Is it easy to assemble and disassemble?

7. What problems related to the prime mover (2½-ton truck, helicopter, etc.) are associated with the movement of field feeding apparatus (to include all equipment, rations and accessories)?

8. What could be done to increase the mobility of the current field feeding equipment?

9. What is your opinion of preparing food while moving between locations?
Advantages? Disadvantages?

10. What methods could be used to store perishables in the field in a satisfactory manner?

11. What is the greatest problem associated with field feeding?

12. What equipment do you consider necessary to feed a standard A-ration menu to a 200-man company in the field?

13. What equipment do you consider necessary to provide adequate facilities for cleaning of kitchen equipment and personal mess gear?

14. What additional accessory equipment would facilitate the preparation, and/or serving of food in field situations?

15. What are the advantages and disadvantages of mechanical field refrigeration? In your opinion, is it practical?

16. What type of shelter or protective cover would be most adequate for field food preparation?

17. What major item(s) of equipment not currently in the system, if added, would be of most benefit to field feeding?

18. What advantages and/or disadvantages (KP reduction, equipment, time, convenience) could be achieved through the use of disposable mess gear vs. non-disposable mess gear?

19. Is extensive maintenance required on any piece of field mess equipment currently in the system? What is the cause of the excessive maintenance?

20. What modifications to those item(s) of field mess equipment currently in the system could be performed to increase their usefulness as field feeding apparatus?

21. What, if any, safety hazards have you encountered with the present field feeding systems?

22. If you were designing a field feeding system, what would be your most important consideration(s)?

23. What is your opinion of the following concept? "The food service system for the Army in the field will be characterized by the extensive use of convenience foods. High quality food service will not be dependent on the skill of the cooks and bakers."

APPENDIX D

DAILY A-LA-CARTE BREAKFAST MENU

ITEM	QUANTITY
Chilled Fruit or Juice	Five gallons (juice) 45 pounds/4 gallons (fruit)
Ready-to-Eat Cereal	63-125 packages
Hot Cereal	17.5 gallons
Fresh Milk	31.25 gallons
Eggs to Order	41.68 dozen
Griddle Cakes/Syrup	4 recipes/month
French Toast/Syrup	2 recipes/month
Meat	30 pounds
Potatoes	57.5 pounds
Special Hot Breads	500 rolls (20 pans)
Toast/Butter	Issued (bread) 7.5 lbs. (butter)
Jam/Jelly	Condiment
Tea/Coffee	15.62 gallons (coffee) Condiment (tea)

APPENDIX E

SUPPER/DINNER MENU PATTERN

MAJOR OPERATION	QUANTITY
Grill	125 pounds
Deep Fry	95 pounds
Pot Cookery	
Soup	15.62 gallons
Vegetable 1	20 pounds
Vegetable 2	20 pounds
Potatoes, Mashed	10 gallons
Beverages (coffee)	7.81 gallons
Roast	100-125 pounds
Bake	43 pies 6 pans (field)
Salad	7.8 gallons
Milk	15.62 gallons

APPENDIX F

- I. SHELTER ANALYSIS
- II. VEHICLE ANALYSIS

Table VIII. Shelter Analysis

<u>Representative Shelter</u>	<u>Length</u>	<u>Width</u>	<u>Height</u>	<u>Weight (In lbs.)</u>	<u>Unit Cost</u>
1. Shelter, Electrical Equipment, S-280, rigid, non-expandable	146"	87"	83"	1,300	\$ 2,668.65
2. Shelter, Electrical Equipment, US Marine Corps, FSN 5410-830-0143, rigid, non-expandable	146"	87"	83"	6,140	1,500.00
3. Electrical Equipment Shelter (Hawk Air Defense Missile System) rigid, non-expandable, limited procurement	190"	85"	90 $\frac{1}{4}$ "	5,300	8,700.00
4. Shelter, Electrical Equipment, US Marine Corps, FSN 5410-380-3103, rigid, non-expandable	142"	81"	83"	1,412	5,000.00
5. MUST Expandable Shelter, rigid, expandable	144"***	216"	96"	4,200	39,000.00
6. Shelter, Electrical Equipment, S-141C, rigid, non-expandable	142"	81"	82"	1,200	2,516.00
7. Shelter, Electrical Equipment, S-354, US Marine Corps, rigid, non-expandable	142"	83"	74"	5,000	33,000.00

*All shelters are standard length except No. 3

**Expanded length. All shelters are non-expandable except No. 5

Table IX. Vehicle Analysis

Type*	Military Design No.	Capacity (In tons)	Wheels	Curb Weight (In lbs)	Maximum Weight (Vehicle + Payload)	Unit Cost	
					Cross-Country (In lbs)	Highway (In lbs)	
Chassis Trailer	M-116	3/4	2	875	3,000	3,750	\$ 760.24
Chassis Trailer	M-103	1-1/2	2	1,660	5,750	7,250	947.00
Flatbed Trailer	M-794	4	4	4,162	12,162	12,162	7,000.00
Chassis Trailer	M-390	2	2	3,650	7,650	7,650	3,746.25
Chassis Trailer	M-200	2-1/2	2	2,410	7,410	9,410	1,315.00
Truck Cargo (with winch)	M-35	2-1/2	6 x 6	12,880	17,880	23,380	9,380.00

*See Figures 2 to 7

FED. SUP CLASS
2330

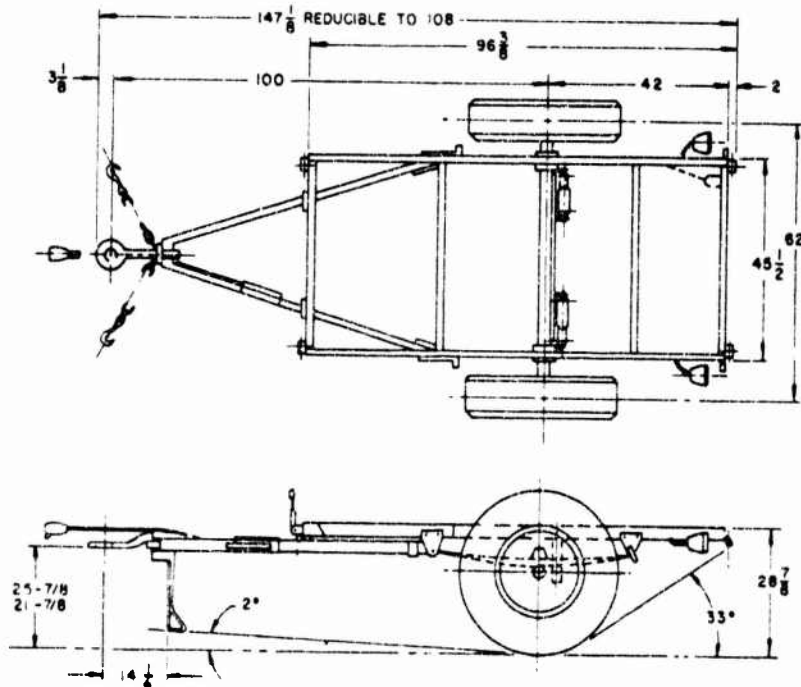
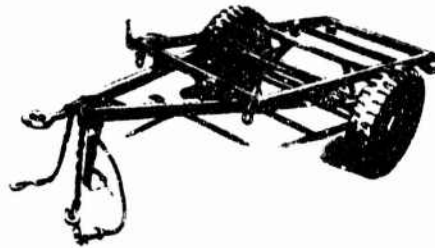

REVIEW ACTIVITIES
USER ACTIVITIES

This military standard is mandatory for use by all Departments and Agencies of the Department of Defense. Selection for all new engineering and design applications and for repetitive use shall be made from this document.

CERTAIN PROVISIONS OF THIS STANDARD, IDENTIFIED BY AN ASTERISK (*) ARE THE SUBJECT OF INTERNATIONAL STANDARDIZATION AGREEMENT NATO-STANAG 2803-A (EDITION 3). WHEN REVISION OR CANCELLATION OF THIS STANDARD IS PROPOSED WHICH WILL AFFECT OR VIOLATE THE INTERNATIONAL AGREEMENT CONCERNED, THE PREPARING ACTIVITY WILL TAKE APPROPRIATE RECONCILIATION ACTION THROUGH INTERNATIONAL STANDARDIZATION CHANNELS, INCLUDING DEPARTMENTAL STANDARDIZATION OFFICES, IF REQUIRED.

DIMENSIONS ARE IN INCHES AND ARE SHOWN FOR ENGINEERING REFERENCE ONLY.

(A) UPDATED IN ACCORDANCE WITH ASD PROGRAM FOR FIVE YEAR CYCLIC REVIEW.

APPROVED 11 SEPT 1962 REVISED (A) 6 DEC 1969

MS PART NO.	ENGINEERING PARTS LIST
MS 53028-1	8736398

P.A. ARMY-AT Other Cust NAVY-MC	INTERNATIONAL INTEREST	TITLE CHASSIS, TRAILER, 3/4 TON, 2 WHEEL, MILITARY DESIGN, M 116 A1	MILITARY STANDARD MS 53028
PROCUREMENT SPECIFICATION MIL-C-48180	SUPERSEDES		SHEET 1 OF 2

DD FORM 872-1 (Continued)

PREVIOUS EDITIONS OF THIS FORM ARE OBSOLETE

Figure 2. M-116 Chassis Trailer, 3/4-ton, 2-wheel.

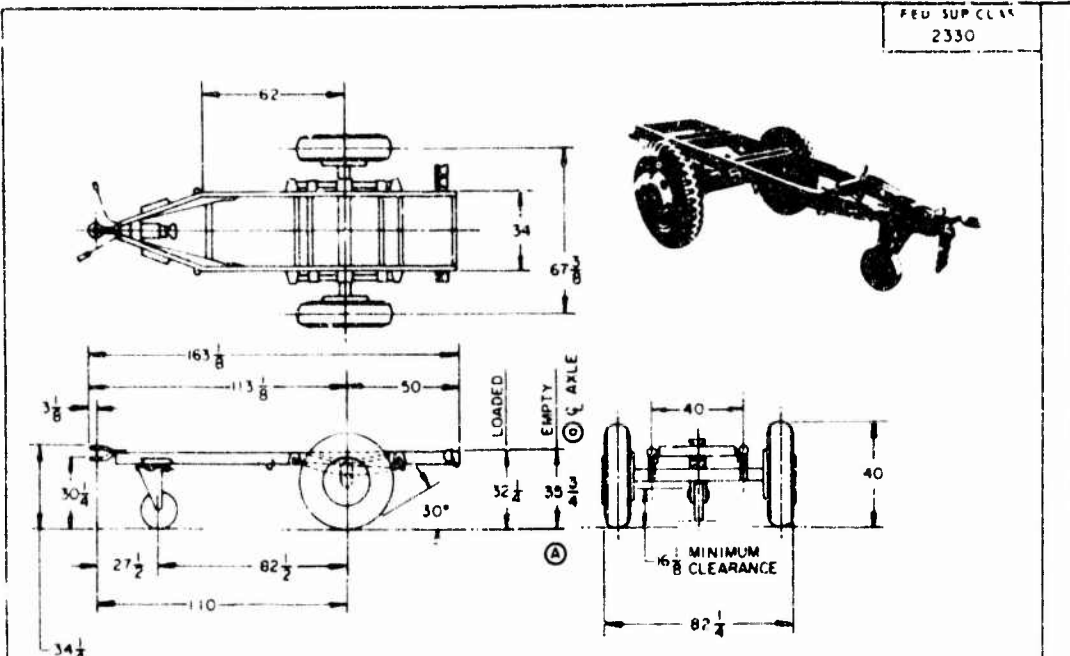

VEHICLE CHARACTERISTICS

(REFERENCE WEIGHTS INFORMATION ONLY)

(A) REVIEW ACTIVITIES: ARMY-GL
 (A) USER ACTIVITIES: ARMY-EL, MI, NAVY-DOCKS, AF-11, 25, 84

CURB WEIGHT: 1660 LBS.
WEIGHT DISTRIBUTION:
 LUNETTE EYE 198 LBS.
 AXLE 1472 LBS.
 LANDING GEAR 250 LBS.
 AXLE 1410 LBS.

WHEELS: Disc, offset MS 53044-5 (A)

TIRES: 9.00x20 8 PLY, MS 35388-16
 TREAD DESIGN NDCC, Tube MS 35392-13

MAX. WEIGHT: INCLUDING BODY AND PAYLOAD
 WITH PAYLOAD EVENLY DISTRIBUTED

	CROSS COUNTRY	HIGHWAY
LUNETTE	360 LBS.	473 LBS.
AXLE	5370 LBS.	7757 LBS.
TOTAL	5730 LBS.	8230 LBS.

BRAKES: SERVICE INSTALL.
 PART NO. 8724497
 DRUM SIZE - 15x3
 ACTUATION - AIR/HYDRAULIC

BRAKES: PARKING - INSTALL.
 PART NO. 8742446
 DRUM SIZE - 15x3
 ACTUATION - MANUAL

FORDING DEPTH: SUBMERSIBLE FOR 15 MINUTES

MAXIMUM TOWING SPEED:

CROSS COUNTRY	20 M.P.H.
HIGHWAY	50 M.P.H.

LUNNETTE: COUPLER - DRAWBAR, RING MS 51339-2 (A)

TIE DOWNS: NO. AND LOCATION - 3
 3 EACH SIDE OF FRAME PART No. 7979507

LANDING GEAR: HAND LIFT, OFFSET SWIVEL, SPRING STRUT TYPE
 LANDING WHEEL - BASTER TYPE PART NO. 7979980

ADDITIONAL EQUIPMENT AVAILABLE:

SHOCK ADSORBER KIT - PART No. 8358778
 SUPPORT LEG KIT - PART No. 8481929

ELECTRICAL SYSTEM: INSTALLATION PART NO. 8747900
 POTENTIAL - 24 VOLTS
 STOPLIGHT - TAILLIGHT, VEHICULAR: RH & LH MS 51329-1
 STOPLIGHT - VEHICULAR: BLACKOUT (1) REQ'D MS 51302-1

THIS VEHICLE SHALL BE IN ACCORDANCE WITH REFERENCED DRAWINGS PART NO. 8358991 COPIES OF WHICH MAY BE OBTAINED FROM ARMY TANK AUTOMOTIVE CENTER, DETROIT ARSENAL, WARREN, MICHIGAN 48090. ATTN: STANDARDIZATION BRANCH

FRAME: ASSEMBLY PART No. 7979967
 CROSS MEMBERS - 6
 SIDE RAIL - CHANNEL - 5 1/16 x 2 x 3/16
 SECTION MODULUS - 2.41 IN.³
AXLE: TUBULAR MS 35865-A1

DIMENSIONS ARE IN INCHES AND ARE SHOWN FOR ENGINEERING REF. ONLY.

SPRINGS: FLAT LEAF, EYE PART No. 7368628
 2 1/2 WIDE x 48 LONG, 12 LEAVES
 AUXILIARY SPRING, 5 LEAVES PART No. 7411042

MS PART NO	ENGINEERING PARTS LIST
MS 53029-1	8358991

P.A. MOTOACT

Drawn by
 NOV MC

**CHASSIS, TRAILER, (MILITARY DESIGN)
 M 103 A3, 1-1/2 TON, 2 WHEEL**

MILITARY STANDARD

MS 53029

ARMY FORCE PARA (84) (A)
 REVISIONS SPECIFICATION SUPERSEDES
 MIL-C 45150

SHEET 1 OF 1

DD FORM 672-1

APPROVED 11 SEP 1962 REVISED 11 MARCH 1965

Figure 3. M-103 Chassis Trailer, 1-1/2-ton, 2-wheel.

FED. SUP CLASS
2330

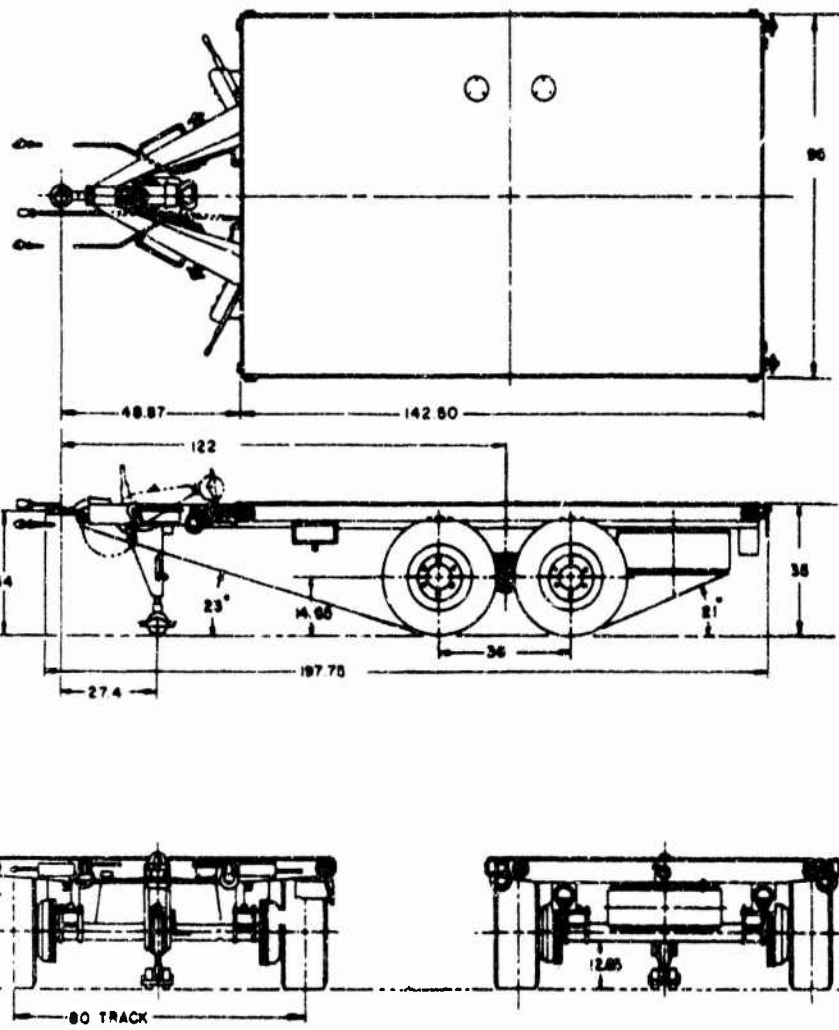

CERTAIN PROVISIONS OF THIS STANDARD, IDENTIFIED BY AN ASTERISK (*) ARE THE SUBJECT OF INTERNATIONAL STANDARDIZATION AGREEMENT NATO STANAG 2803-A (EDITION 3). WHEN REVISION OR CANCELLATION OF THIS STANDARD IS PROPOSED WHICH WILL AFFECT OR VIOLATE THE INTERNATIONAL AGREEMENT CONCERNED, THE PREPARING ACTIVITY WILL TAKE APPROPRIATE RECONCILIATION ACTION THROUGH INTERNATIONAL STANDARDIZATION CHANNELS, INCLUDING DEPARTMENTAL STANDARDIZATION OFFICES, IF REQUIRED.

DIMENSIONS ARE IN INCHES AND ARE SHOWN FOR ENGINEERING REFERENCE ONLY.

REVIEW ACTIVITIES -
USAR ACTIVITIES - ARMY-ME NAVY-YO, MC

THIS MILITARY STANDARD IS MANDATORY FOR USE BY ALL DEPARTMENTS AND AGENCIES OF THE DEPARTMENT OF DEFENSE. SELECTION FOR ALL NEW ENGINEERING AND DESIGN APPLICATIONS AND FOR REPETITIVE USE SHALL BE MADE FROM THIS DOCUMENT.

APPROVED 14 7-DECEMBER 1958 REVISED

P.A. ARMY-AT Other Cui: AF-84		INTERNATIONAL INTEREST?	TITLE TRAILER, FLATBED, 4 TON, 4 WHEEL, MILITARY DESIGN, M 794	MS PART NO. MS 52114 -1	ENGINEERING PARTS LIST 0739788
PROCUREMENT SPECIFICATION MIL-T-82073		SUPERSEDES		MILITARY STANDARD MS 52114	
				UNIT 1 0 1	

DD FORM 672-1 (Continued)

PREVIOUS EDITIONS OF THIS FORM ARE OBSOLETE

Figure 4. M-794 Trailer, Flatbed, 4-ton, 4-wheel.

CHARACTERISTIC SHEET

ORDNANCE TANK AUTOMOTIVE COMMAND

CHASSIS TRAILER, 2-TON, 2-WHEEL, M390
 TYPE:

SECTION: DWT-4
 CODE: DWT-623
 STATUS: LIMITED PRODUCTION (LP)
 DATE: 5 APRIL 1961

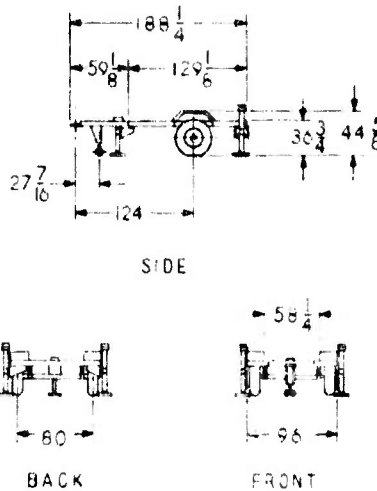

PRIME MOVER (TRUCK, D400, 2-1/2 TON, 4 X 4)

MANUFACTURER: BIRD'S NEST PATENTING CO., INC.

MODEL: M390

ORDNANCE STOCK NO.: M390A1A

PUBLICATIONS:

TECHNICAL MANUAL, TM 9-2250-01-15

OPERATING INSTRUCTIONS, OI 9-2250-01-10

CURBWEIGHT: 1610 LBS.

WEIGHT DISTRIBUTION:

FRONT AXLE: 1500 LBS.

REAR AXLE: 1110 LBS.

GROSS WEIGHT (INCL. BODY & PAYLOAD): 2710 LBS.

SHIPPING DATA:

WEIGHT: 2710 LBS.

HEIGHT: 48 INCHES.

LOADS DATA:

MAXIMUM WEIGHT: 2710 LBS.

WEIGHT LIMIT: 1355 LBS.

PERCENT OF AXLE: 100%.

PERCENT OF FRONT AXLE: 100%.

MINIMUM GROUND CLEARANCE: 16-1/2 INCHES

DEPARTURE ANGLE: 30 DEGREES

FORDING DEPTH: 12 INCHES

TREAD: 60 INCHES

WHEEL: NONE

LANDING GEAR:

TYPE: TWIN WHEEL

WHEEL: WHITE

ELECTRICAL SYSTEM:

TYPE: 24 VOLTS

TYPE: 24 VOLTS

WARRANTY: 1 YEAR

WARRANTY: 1 YEAR

AXLE TYPE:

TYPE: 2 INCHES

SPRING TYPE:

TYPE: 2 INCHES

TYPE: 2 INCHES

DATE: 1961

WARRANTY: 1 YEAR

AUXILIARY SPRINGS:

TYPE: NONE

SHOCK ABSORBER TYPE:

TYPE: NONE

WHEELS TYPE:

TYPE: 2 INCHES

TYPE: 2 INCHES

TIRE SIZE & PLY: 1400 X 20 - 8 PLY

TYPE: 1400

TYPE: 20 INCHES

BRAKE SERVICE:

TYPE: 1400 X 20

TYPE: 1400 X 20

TYPE: 1400 X 20

TYPE: 1400 X 20

PARKING BRAKE:

TYPE: 1400 X 20

TYPE: 1400 X 20

TYPE: 1400 X 20

TYPE: 1400 X 20

MAXIMUM TOWING SPEED:

TYPE: 20 MPH

TYPE: 20 MPH

TIE DOWNS NO. & LOCATION:

TYPE: 20 MPH

TYPE: 20 MPH

PROJECT ENGINEER: *[Signature]*
 SECTION CHIEF: *[Signature]*
 BRANCH CHIEF: *[Signature]*
 DIVISION CHIEF: *[Signature]*
 DIRECTOR, R & E: *[Signature]*
 DATE APPROVED: 20 April 1961

240 FORM 100-100 100-100 100-100 100-100 100-100 100-100 100-100 100-100 100-100 100-100

Figure 5. M-390 Chassis Trailer, 2-ton, 2-wheel.

CHARACTERISTIC SHEET

ORDNANCE TANK AUTOMOTIVE COMMAND

ORGANIC TRAILER, GENERATOR, 2-1/2 TON, 2 WHEEL, M200AL
TYPE:

SECTION: SWV-4
CODE: SWV-404
STATUS: STANDARD
DATE: 16 DECEMBER 1958

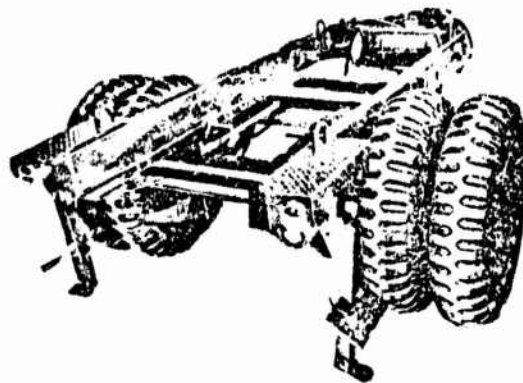

PRIME NOTES

MANUFACTURER UTILITY TOOL & BODY CO., INC.
MODEL M200AL
FEDERAL STOCK NO. 2330-331-2307

PUBLICATIONS

TECHNICAL MANUAL TM 9-8210
SHE. URL 9-SM-0736
LUBRICATION ORDER LO 9-8210
OCM ITEM 35151 DATED 28 JAN. 54

WEIGHT

WEIGHT DISTRIBUTION

NO LOAD
LUNETTE EYE 232 LBS.
AXLE 2178 LBS.
LANDING GEAR LBS.
ALL LBS.

WEIGHT INCL. BODY & PAYLOAD

CROSS COUNTRY 7410 LBS.
HIGHWAY 9410 LBS.

CRIPPING DATA

CUBIC FEET 354
SQUARE FEET 107
D. A. LENGTH 165 IN. REDUCIBLE TO IN.
D. A. WIDTH 93 IN. REDUCIBLE TO IN.
D. A. HEIGHT 40 IN. REDUCIBLE TO IN.

LUNETTE DATA

ORDNANCE NO. 7354577
HEIGHT EMPTY 37-3/4 OR 33-3/4 IN.
TO C. L. OF AXLE 33-1/2 IN.
TO C. L. OF LANDING GEAR 23-3/8 IN.

MINIMUM GROUNDE CLEARANCE 9 IN.

DEPARTURE ANGLE 20°

FORNIBLE DEPTH TOP OF FRAME IN.

TREAD INNER 57 1/2 IN.
OUTER 82 1/2 IN.

LANDING LEG 7392845

SPRING STRUT TYPE
LANDING WHEEL

ELECTRICAL SYSTEM 8742398

POTENTIAL 24 VOLTS
TAIL LAMP ORDNANCE NO. 8378785, 8378786
BLACKOUT LAMP ORDNANCE NO.
REFLECTORS ORDNANCE NO. 506101, 506102

WHEEL TYPE TUBULAR; 10,000 LB.

ORDNANCE NO. 8742397, 7263711

SPRINGER TYPE

SIZE 2 1/2 W X 4 1/2 L0.
NO. OF LEAVES 14
RATE 1200 ± 60 LB./IN.
ORDNANCE NO. 7392819

ORIGINATOR ORDNANCE

ORDNANCE NO.

ORDER NUMBER TYPE

ORDNANCE NO.

WHEELS TYPE

SINGLE OR DUAL WHEELS
ORDNANCE NO. 739621

TIRE SIZE & PLY 9.00 X 20 (8 PLY)
MILITARY PNEUMATIC
TREAD DESIGN NON-DIRECTIONAL, CROSS-COUNTRY
75 PWT. B C C.
RECOMMENDED PRESS 15 MFD, SNOW & SAND LBS.

ORDER SERVICE 8669543, 7411425

DRUM SIZE 15 DIA. X 7
ACTUATION AIR/HYDRAULIC
EMERGENCY RELAY VALVE
AIR RESERVOIR 7411078

ORDER SERVICE 7392815

DRUM SIZE 15 DIA. X 2 1/2
ACTUATION MANUAL
MOUNTING BOTH SIDES (OPERATE INDEPENDENTLY)
EFFECTIVE SLOPE 101 50

MAXIMUM TOWING SPEED

CROSS COUNTRY 30 MPH
HIGHWAY 55 MPH

TIE RODS NO. & LOCATION 8659492

6 TIES - 3 ON EACH SIDE OF FRAME,
POSITIONED FORWARD, CENTER, REAR

PROJECT ENGINEER *James C. Douglas, Jr.*
UNIT CHIEF *W. H. Jones*
SECTION CHIEF *James J. Martinson*
BRANCH CHIEF *James J. Martinson*
CHIEF ENGINEER *A. B. Hayes*
DATE APPROVED 16 Dec 1958

Figure 6. M-200 Chassis Trailer, 2-1/2-ton, 2-wheel.

REVIEW ACTIVITIES: ARMY-EL
 USER ACTIVITIES: NAVY-DOCKS

FED. SUP CLASS
 2320

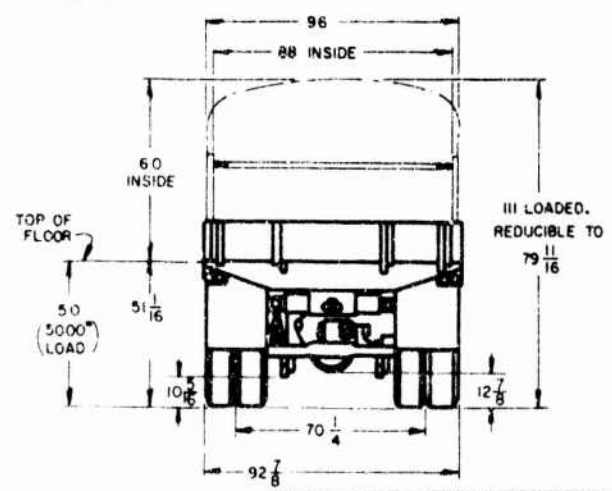
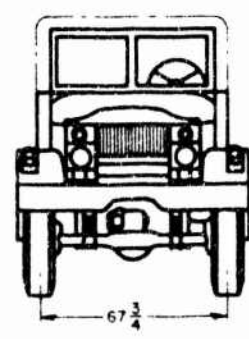
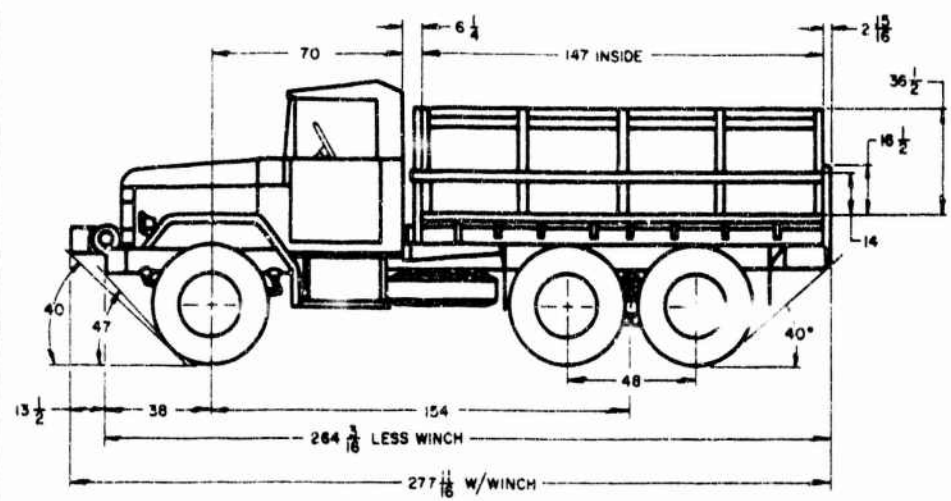

MS PART NO.	DRAWING NO.	
MS 53071-1	8358464	WITH WINCH
MS 53071-2	8358463	LESS WINCH

P.A. MO (ATAC) Other Cust NAVY-MC	TITLE TRUCK, CARGO, 2-1/2 TON, 6 X 6, 154 IN. WHEEL BASE, M35	MILITARY STANDARD MS 53071
PROCUREMENT SPECIFICATION MIL-T-45362	SUPERSEDES	SHEET 1 OF 2

APPROVED 15 MAY 1964 REVISED

This military standard is approved by the Department of Defense and is mandatory for all activities. Submission for all new engineering and design requirements and for repetitive use shall be made from this document.

DD FORM 672-1 (Continued)

Figure 7. M-35 Truck, Cargo, 2-1/2-ton, 6 x 6.

APPENDIX G.

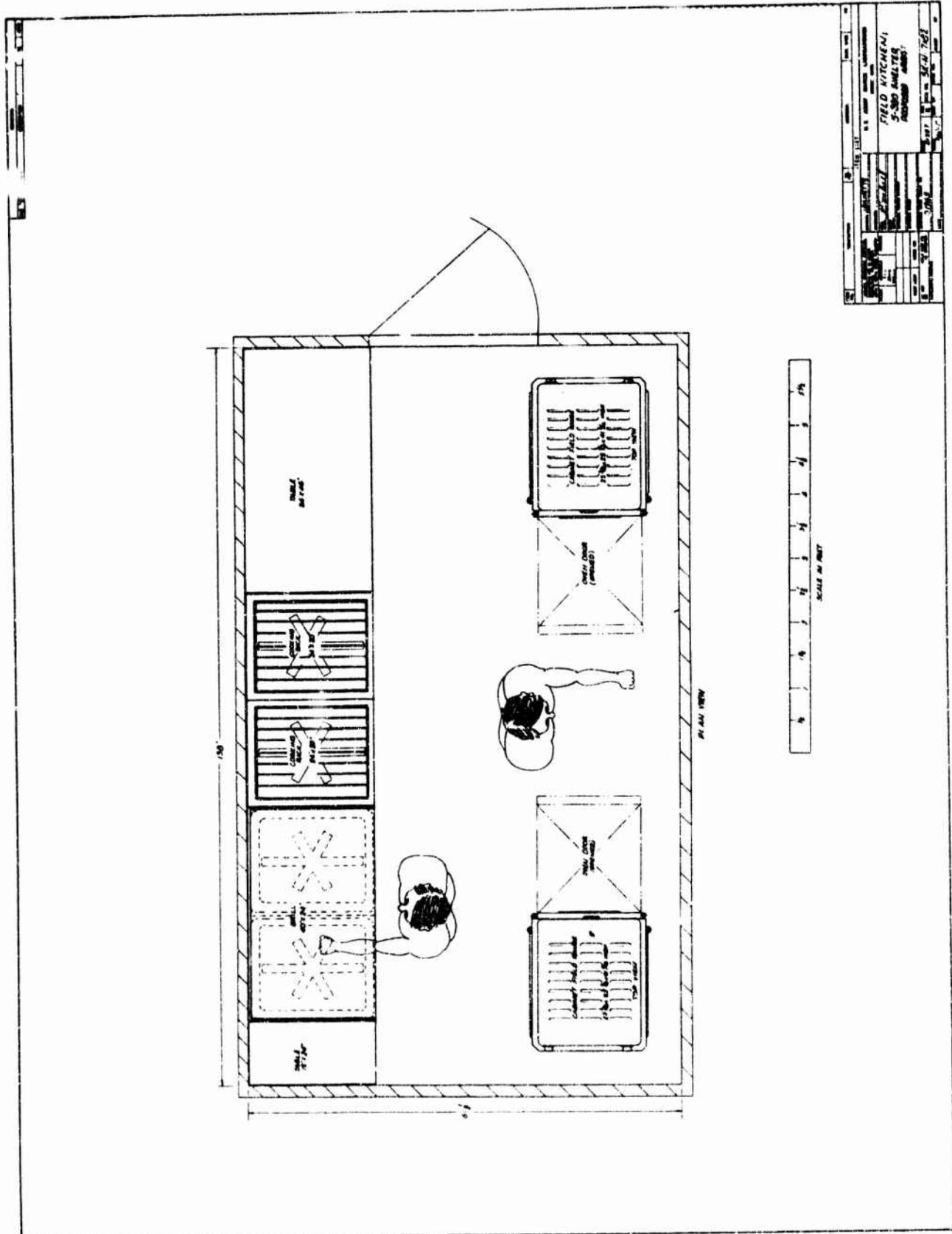

Figure 8. 3-280 Shelter Configuration.

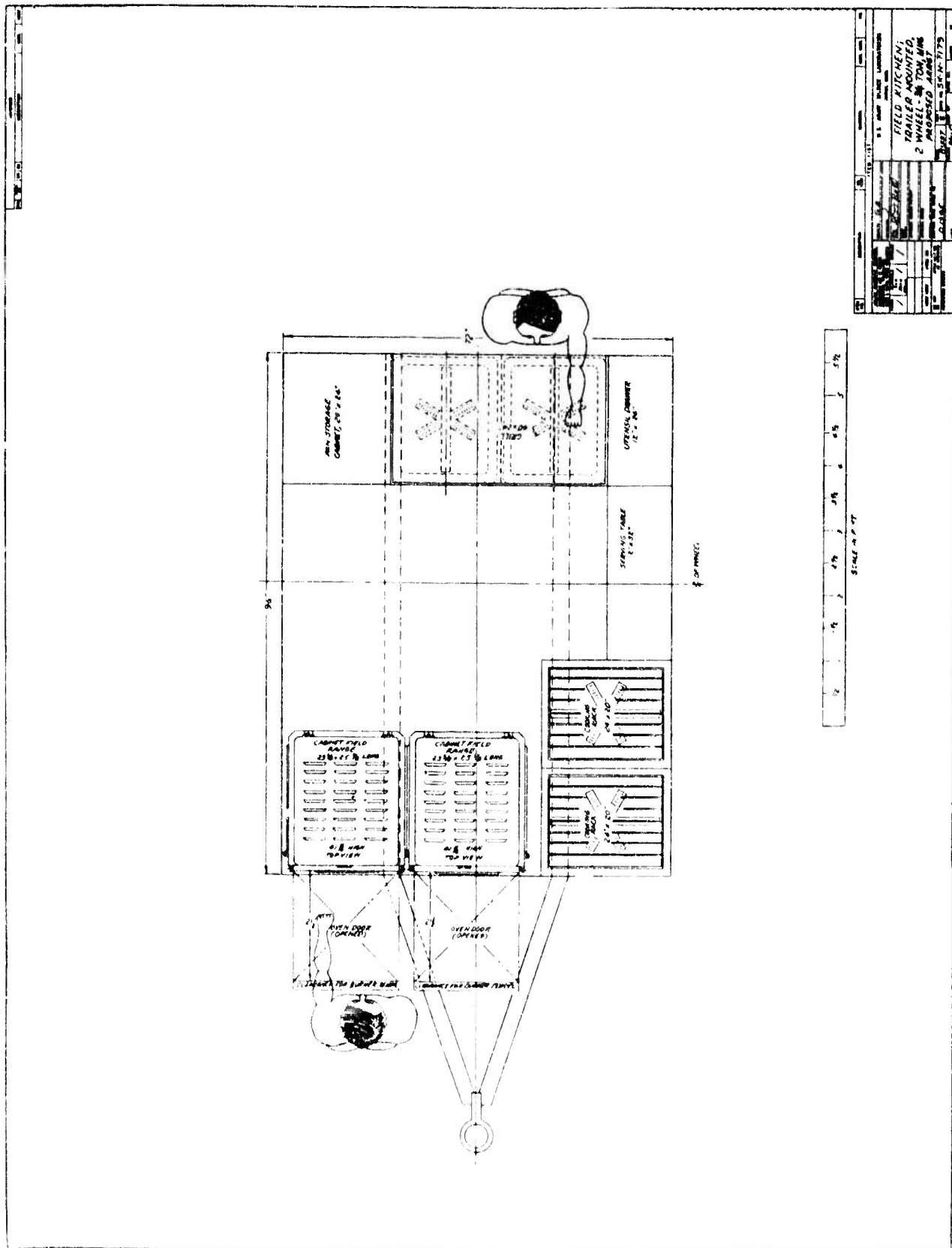

Figure 9. M-116 3/4-ton Trailer Configuration.

APPENDIX I.

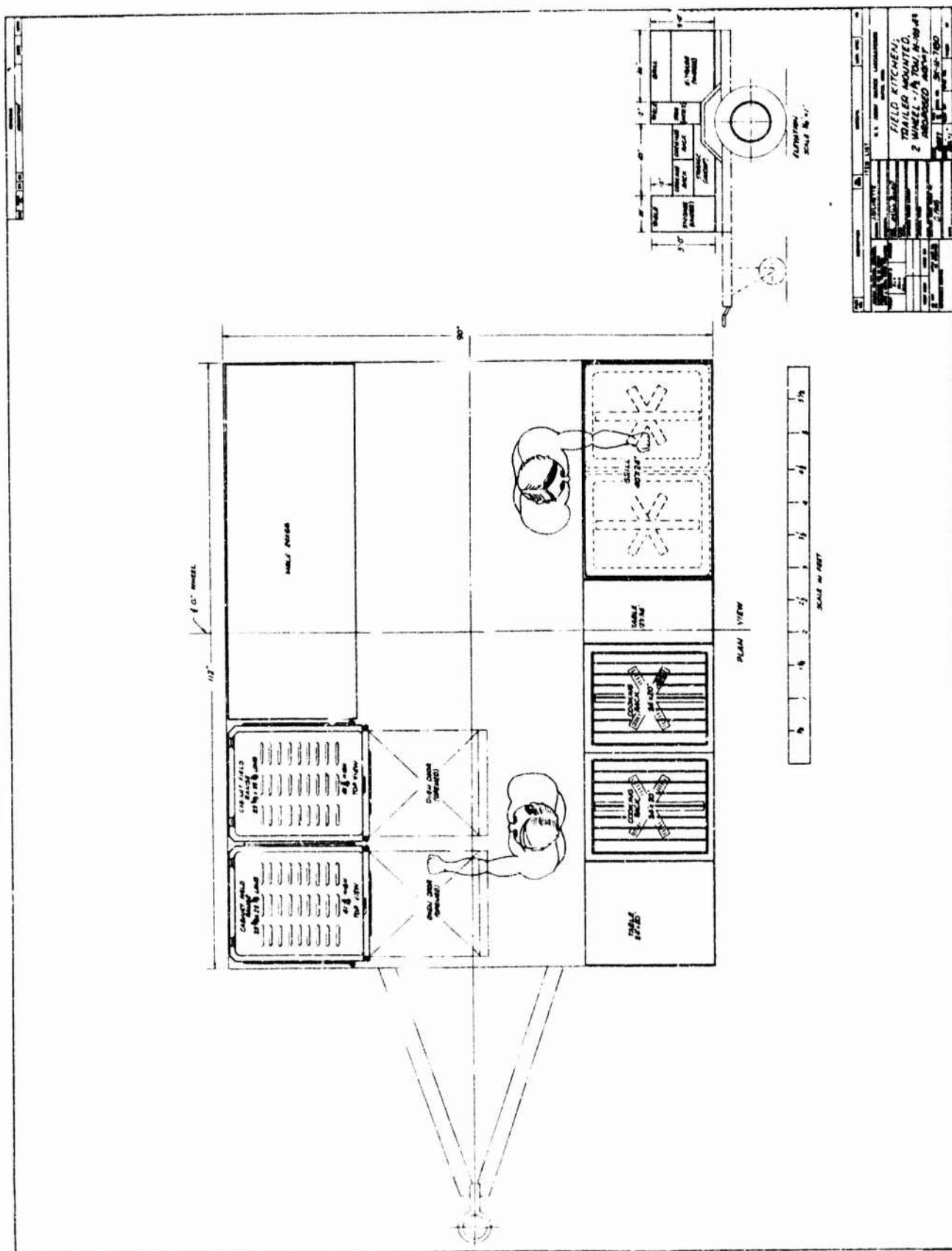

Figure 10. M-103 1-l/2-ton Trailer Configuration.

APPENDIX J.

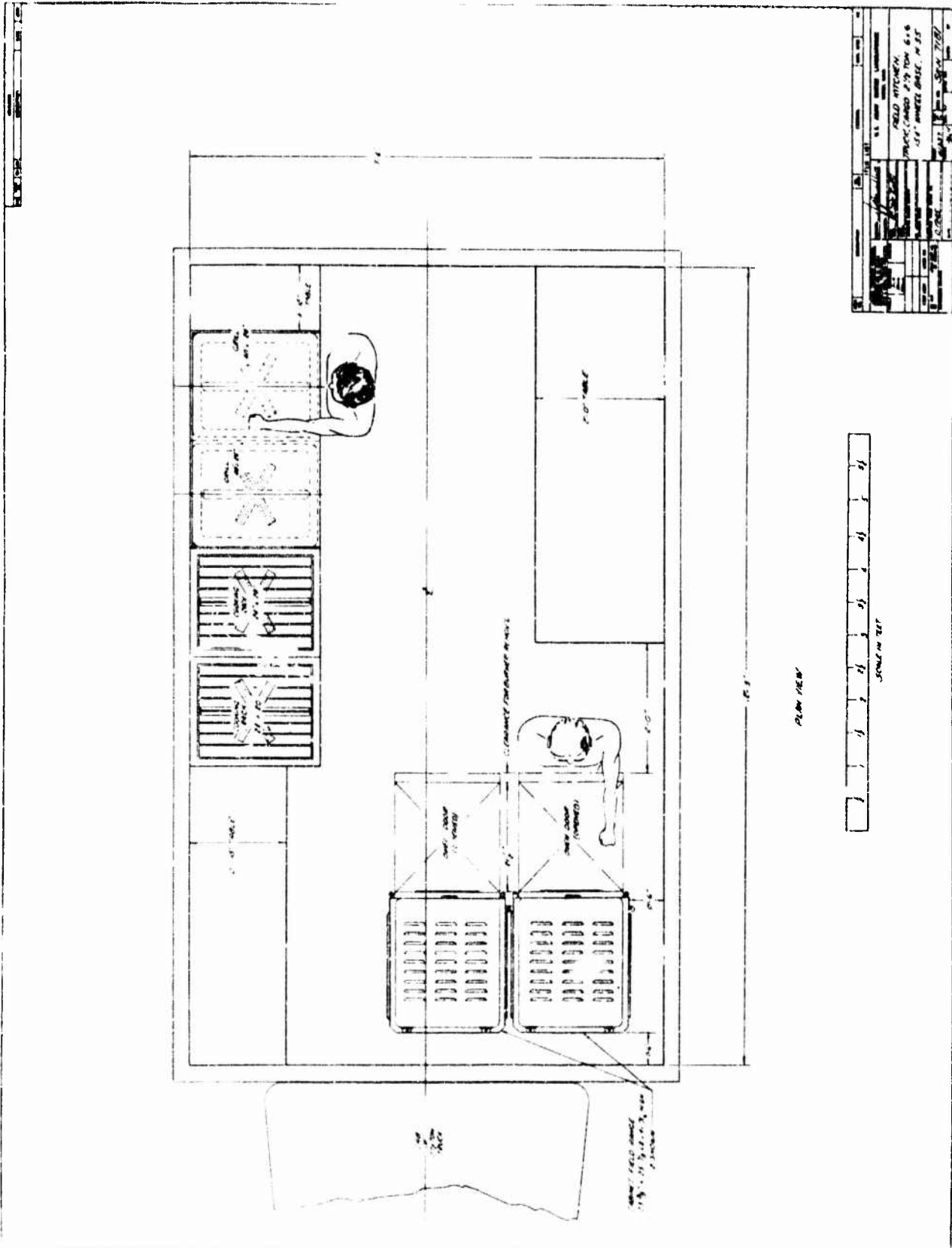

Figure 11. M-35 2-1/2-ton Truck Configuration.

APPENDIX K

PRODUCTION COST ESTIMATES, FIELD KITCHEN LESS VEHICLES

Concept I. Rigid Shelter 2-1/2-ton truck	48
Concept II. Rigid Shelter 1-1/2-ton truck	48
Concept III. Rigid Shelter Dual Axle Trailer	48
Concept IV. Self-contained Soft Shelter 3/4-ton trailer	49
Concept V. Self-contained Soft Shelter 1-1/2-ton trailer	49
Concept VI. Self-contained Soft Shelter 2-1/2-ton truck.	49

PRODUCTION COST ESTIMATE, Food Service Equipment

Design Criteria	51
---------------------------	----

EQUIPMENT COST ESTIMATES

Standard Equipment	52
Non-Standard Equipment	52
Raw Costs	54

APPENDIX K

PRODUCTION COST ESTIMATES, FIELD KITCHEN LESS VEHICLES

CONCEPT I	RIGID SHELTER - 2-1/2-Ton Truck			
	<u>Material (\$)</u>	<u>Labor (\$)</u>	<u>Total (\$)</u>	<u>Weight (lbs.)</u>
A. Shelter	2,668.00	500.00	3,168.00	1200
B Ramps	200.00	75.00	275.00	250
C. Food Service Equipment	1,748.20	120.00	1,868.20	1289
D. Ventilation	400.00	1,000.00	1,400.00	400
E. Generator	1,283.00		1,283.00	285
F. Jack System	500.00	1,000.00	1,500.00	250
TOTAL	6,799.20	2,695.00	9,494.20	3674

Contract Recapitulation

Basic Cost - = 9,494.00
 Overhead @ 100% - (2695)(1.00) + 9,494 = 12,189.00
 G & A @ 20% - (12,189)(.2) + 12,189 = 14,627.00
 Profit @ 10% - (14,627)(.1) + 14,627 = 16,090.00

CONCEPT II	RIGID SHELTER - 1-1/2-Ton Truck			
CONCEPT III	RIGID SHELTER - Dual Axle Trailer			
	<u>Material (\$)</u>	<u>Labor (\$)</u>	<u>Total (\$)</u>	<u>Weight (lbs.)</u>
A. Shelter	2,668.00	500.00	3,168.00	1200
B. Ramps	200.00	75.00	275.00	250
C. Food Service Equipment	1,748.20	120.00	1,868.20	1289
D. Ventilation	400.00	1,000.00	1,400.00	400
E. Generator	1,283.00		1,283.00	285
TOTAL	6,299.20	1,695.00	7,994.20	3424

Contract Recapitulation

Basic Cost - = 7,994.00
 Overhead @ 100% - (1695)(1.00) + 7,994 = 9,689.00
 G & A @ 20% - (9,689)(.2) + 9,689 = 11,627.00
 Profit @ 10% - (11,627)(.1) + 11,627 = 12,790.00

CONCEPT IV SELF-CONTAINED SOFT SHELTER - 3/4-Ton Trailer

CONCEPT V SELF-CONTAINED SOFT SHELTER - 1-1/2-Ton Trailer

	<u>Material (\$)</u>	<u>Labor (\$)</u>	<u>Total (\$)</u>	<u>Weight (lbs.)</u>
A. Tentage - Trailer	75.00	75.00	150.00	15
B. Ramps - Trailer	400.00	75.00	475.00	800
C. Platform - Trailer	350.00	75.00	425.00	250
D. Food Service Equipment	1,748.20	120.00	1,868.20	1289
TOTAL	2,573.20	345.00	2,918.20	2354

Contract Recapitulation

Basic Cost - = 2,918.00
 Overhead @ 100% - (345)(1.00) + 2,918 = 3,263.00
 G & A @ 20% - (3263)(.2) + 3,263 = 3,916.00
 Profit @ 10% - (3916)(.1) + 3,916 = 4,308.00

CONCEPT VI SELF-CONTAINED SOFT SHELTER - 2-1/2-Ton Truck

	<u>Material (\$)</u>	<u>Labor (\$)</u>	<u>Total (\$)</u>	<u>Weight (lbs.)</u>
A. Tentage - Truck	100.00	50.00	150.00	50
B. Ramps - Truck	200.00	75.00	275.00	250
C. Food Service Equipment	1,748.20	120.00	1,868.20	1289
D. Platform - Truck	450.00	50.00	500.00	105
TOTAL	2,498.20	290.00	2,793.20	1694

Contract Recapitulation

Basic Cost - = 2,793.00

Overhead @ 100% - (295)(1.00) + 2,793 = 3,088.00

G & A @ 20% - (3088)(.2) + 3,088 = 3,706.00

Profit @ 10% - (3706)(.1) + 3,706 = 4,077.00

PRODUCTION COST ESTIMATE - Food Service Equipment

Design Criteria

1. Food Service Equipment is identical for all concepts.
2. T. O. & E equipment on hand by troop units will not be reissued and costs for these items will not be charged against production costs, supplementary quantities of T. O. & E items are included.

ITEM	Unit Cost (\$)	Labor	Require- ment	Total Cost (\$)	Unit Weight (lbs.)	Total Weight (lbs.)
1. Cooking Racks	35.00	(10)	4	140.00	30	120
2. Grill	85.00	(5)	1	85.00	120	120
3. Burner, M-2	73.00		2	146.00	42	84
4. Pans, Bake & Roast	36.00		2	72.00	4	8
5. Pans, Baking	3.35		12	40.20	1	12
6. Jugs, Insulated	67.00		4	268.00	5	20
7. Containers, Insulated	57.00		16	912.00	45	820
8. Counters & Cabinetry	135.00	(75)	1	135.00	75	75
9. Tables (two each)	70.00	(30)	1	70.00	30	30
TOTAL		(120)		1,868.20		1,289

EQUIPMENT COST ESTIMATES

	Unit/ Material Cost (\$)	Labor (\$)	Total Unit Cost (\$)	Weight per unit (lbs.)
1. Standard Equipment				
A. Vehicles				
(1) Truck - 2-1/2 ton	9,380.00	-	9,380.00	-
(2) Trailer - 1-1/2 ton	947.00	-	947.00	1660
(3) Trailer - 3/4 ton	760.00	-	760.00	875
(4) Trailer - dual axle	7,000.00	-	7,000.00	-
B. Other				
(1) Generator	1,283.00	-	1,283.00	285
(2) Refrigerator - 70 Cu. Ft.	2,000.00	-	2,000.00	-
C. Food Service Equipment				
(1) Range, M-1959	301.00	-	301.00	275
(2) Burner, M-2	73.00	-	73.00	42
(3) Accessory Outfit	83.00	-	83.00	10
(4) Container, Food Insulated	28.90	-	28.90	10
(5) Pan, Baking and Roasting	36.00	-	36.00	4
(6) Pan, Baking	3.35	-	3.35	1
(7) Jug, Insulated	67.00	-	67.00	5
2. Non-Standard Equipment				
A. Non-Food Service Equipment				
(1) Ramps - Trailer	400.00	75.00	475.00	800
(2) Ramps - Truck	200.00	75.00	275.00	250

	Unit/ Material Cost (\$)	Labor (\$)	Total Unit Cost (\$)	Weight per unit (lbs.)
(3) Platform - Trailer	350.00	75.00	425.00	250
(4) Platform - Truck	450.00	50.00	500.00	105
(5) Shelters, S-280	2,668.00	500.00	3,168.00	1,200
(6) Shelter Jack System	500.00	1,000.00	1,500.00	250
(7) Shelter Ventilation	400.00	1,000.00	1,400.00	150
(8) Tentage - Trailer	75.00	75.00	150.00	15
(9) Tentage - Truck	100.00	50.00	150.00	50
B. Food Service Equipment				
(1) Cooking Racks	25.00	10.00	35.00	30
(2) Grill Top	80.00	5.00	85.00	120
(3) Tables	40.00	30.00	70.00	30
(4) Counter and Cabinets	60.00	75.00	135.00	75
(5) Insulated Containers	57.00	-	57.00	45

RAW COSTS

1. Tentage - 9.8502 duck - 43¢ per yard
12.2902 duck - 70¢ per yard
2. Steel - Hot Rolled - 55¢ per pound
Cold Rolled - 75¢ per pound

3. Truck Platform

9' x 4' Sections

Weight - 45 pounds
Cost - \$180

7' x 4' Sections

Weight - 105 pounds
Cost - \$140 per section

Platform Cost $\$140 \times 3 = \$420 + \$80 = \500
Accessories - \$80

4. Refrigerator - 70 Cubic Feet
FSN 4110-965-1222
Cost \$749.00

Refrigeration Unit, Mechanical 5000, Gasoline Engine operated
FSN 4110-933-6114
Cost \$1,409.00

UNCLASSIFIED

Security Classification

DOCUMENT CONTROL DATA - R & D

(Security classification of title, body of abstract and indexing annotation must be entered when the overall report is classified)

1. ORIGINATING ACTIVITY (Corporate author) U. S. Army Natick Laboratories Natick, Massachusetts 01760		2a. REPORT SECURITY CLASSIFICATION UNCLASSIFIED															
		2b. GROUP															
3. REPORT TITLE An evaluation of alternative mobile field kitchen concepts.																	
4. DESCRIPTIVE NOTES (Type of report and inclusive dates) Technical report.																	
5. AUTHOR(S) (First name, middle initial, last name) John C. Perry, Gordon D. Bell, and CPT Henry M. Toczykowski																	
6. REPORT DATE Feb 72	7a. TOTAL NO. OF PAGES 54	7b. NO. OF REFS 4															
8a. CONTRACT OR GRANT NO. b. PROJECT NO. 1J664713D548		8a. ORIGINATOR'S REPORT NUMBER(S) 73-44-GP															
c. d.		8b. OTHER REPORT NO(S) (Any other numbers that may be assigned this report)															
10. DISTRIBUTION STATEMENT Approved for public release; distribution unlimited.																	
11. SUPPLEMENTARY NOTES		12. SPONSORING MILITARY ACTIVITY U. S. Army Natick Laboratories Natick, Massachusetts 01760															
13. ABSTRACT Six field feeding concepts were studied and evaluated for potential use as a mobile field kitchen for the U. S. Army. A thorough analysis of the major design consideration and parameters was conducted. They are: <table border="0"><thead><tr><th><u>Factors</u></th><th><u>Definition</u></th></tr></thead><tbody><tr><td>1. Storage</td><td>Ability to store all food, equipment and ancillary gear.</td></tr><tr><td>2. Transportability</td><td>Ease of assembly/disassembly and movement between locations.</td></tr><tr><td>3. Cook Enroute</td><td>Ability to prepare food while in transit.</td></tr><tr><td>4. Shelter</td><td>Adequate protection from the elements.</td></tr><tr><td>5. Safety</td><td>Ability of system to function without fear of injury to personnel.</td></tr><tr><td>6. Anthropometrics</td><td>Man's physical characteristics as related to his working environment.</td></tr></tbody></table>				<u>Factors</u>	<u>Definition</u>	1. Storage	Ability to store all food, equipment and ancillary gear.	2. Transportability	Ease of assembly/disassembly and movement between locations.	3. Cook Enroute	Ability to prepare food while in transit.	4. Shelter	Adequate protection from the elements.	5. Safety	Ability of system to function without fear of injury to personnel.	6. Anthropometrics	Man's physical characteristics as related to his working environment.
<u>Factors</u>	<u>Definition</u>																
1. Storage	Ability to store all food, equipment and ancillary gear.																
2. Transportability	Ease of assembly/disassembly and movement between locations.																
3. Cook Enroute	Ability to prepare food while in transit.																
4. Shelter	Adequate protection from the elements.																
5. Safety	Ability of system to function without fear of injury to personnel.																
6. Anthropometrics	Man's physical characteristics as related to his working environment.																

DD FORM 1473
NOV 68

REPLACES DD FORM 1473, 1 JAN 64, WHICH IS OBSOLETE FOR ARMY USE.

UNCLASSIFIED
Security Classification

14. KEY WORDS	LINK A		LINK B		LINK C	
	ROLE	WT	ROLE	WT	ROLE	WT
Acceptability	8					
Evaluation	8					
Operations	8					
Cooking Devices	9					
Kitchen Equipment & Supplies	9					
Kitchens	9					
Mobile Equipment	9					
Field Feeding System	9					
Field Cooking	9					
Military Feeding	4					
Military Rations	4					

Abstract (Con't)

- | | |
|----------------|--|
| 7. Sanitation | Free from agents injurious to health. |
| 8. Environment | Ability to control and maintain workable atmospheric conditions. |
| 9. Workspace | Sufficient worktable space for food preparation. |
| 10. Functional | Configuration conducive to efficient work flow. |

It is concluded that two of the six concepts evaluated be considered. They are a self-contained soft shelter kitchen mounted on a standard 1 1/2-ton trailer chassis and a self-contained soft shelter kitchen mounted on 2 1/2-ton wheel cargo truck vehicle.