

AD-764 376

MEASURED WATER VAPOR ABSORPTION  
COEFFICIENTS FOR TWO HIGHLY ABSORBED CO  
LASER LINES

Ronald K. Long, et al

Ohio State University

Prepared for:

Advanced Research Projects Agency  
Rome Air Development Center

June 1973

DISTRIBUTED BY:

**NTIS**

National Technical Information Service  
U. S. DEPARTMENT OF COMMERCE  
5285 Port Royal Road, Springfield Va. 22151

RADC-TR-73-225  
Final Technical Report  
June 1973



AD 764376

MEASURED WATER VAPOR ABSORPTION COEFFICIENTS  
FOR TWO HIGHLY ABSORBED CO LASER LINES

The Ohio State University  
**ElectroScience Laboratory**

Department of Electrical Engineering  
Columbus, Ohio 43212

Sponsored by  
Defense Advanced Research Projects Agency  
ARPA Order No. 1279

Approved for public release;  
distribution unlimited.

The views and conclusions contained in this document are those of the authors and should not be interpreted as necessarily representing the official policies, either expressed or implied, of the Defense Advanced Research Projects Agency or the U. S. Government.

Reproduced by  
**NATIONAL TECHNICAL  
INFORMATION SERVICE**  
U S Department of Commerce  
Springfield VA 22151

Rome Air Development Center  
Air Force Systems Command  
Griffiss Air Force Base, New York



82

MEASURED WATER VAPOR ABSORPTION COEFFICIENTS  
FOR TWO HIGHLY ABSORBED CO LASER LINES

R. K. Long  
F. S. Mills  
G. L. Trusty

Contractor: The Ohio State University  
Contract Number: F30602-72-C-0016  
Effective Date of Contract: 23 June 1971  
Contract Expiration Date: 30 June 1973  
Amount of Contract: \$211,000.00  
Program Code Number: OE20

Principal Investigator: Dr. Ronald K. Long  
Phone: 614 422-6077

Research Associate: Mr. Frank S. Mills  
Phone: 614 422-6726

Project Engineer: Mr. James W. Cusack  
Phone: 315 330-3145

Approved for Public release;  
distribution unlimited.

This research was supported by the Defense  
Advanced Research Projects Agency of the  
Department of Defense and was monitored by  
James W. Cusack, RADG (OCSE), GAFB, NY  
13441 under Contract F30602-72-C-0016.

*ia*

PUBLICATION REVIEW

This technical report has been reviewed and is approved

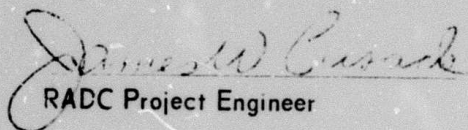
  
RADC Project Engineer

UNCLASSIFIED

SECURITY CLASSIFICATION OF THIS PAGE (When Data Entered)

REPORT DOCUMENTATION PAGE		READ INSTRUCTIONS BEFORE COMPLETING FORM
1. REPORT NUMBER RADC-TR-73-225	2. GOVT ACCESSION NO.	3. RECIPIENT'S CATALOG NUMBER
4. TITLE (and Subtitle) Measured Water Vapor Absorption Coefficients for two Highly Absorbed CO Laser Lines		5. TYPE OF REPORT & PERIOD COVERED Final Apr.-Jun 73
		6. PERFORMING ORG. REPORT NUMBER
7. AUTHOR(s) Dr. R. Long Mr. F. Mills Mr. G. Trusty		8. CONTRACT OR GRANT NUMBER(s) F30602-72-C-0016
9. PERFORMING ORGANIZATION NAME AND ADDRESS Electro Science Laboratory Department of Electrical Engineering The Ohio State Univ., Columbus, OH 43212		10. PROGRAM ELEMENT, PROJECT, TASK AREA & WORK UNIT NUMBERS
11. CONTROLLING OFFICE NAME AND ADDRESS Advanced Research Projects Agency 1400 Wilson Blvd Arlington, VA 22209		12. REPORT DATE June 1973
		13. NUMBER OF PAGES 15 23
14. MONITORING AGENCY NAME & ADDRESS (if different from Controlling Office) Rome Air Development Center Griffiss AFB NY 13441		15. SECURITY CLASS. (of this report) Unclassified
		15e. DECLASSIFICATION/DOWNGRADING SCHEDULE
16. DISTRIBUTION STATEMENT (of this Report) Approved for public release; distribution unlimited		
17. DISTRIBUTION STATEMENT (of the abstract entered in Block 20, if different from Report) Same as above		
18. SUPPLEMENTARY NOTES Monitored by: James W. Cusack Griffiss AFB, NY 13441		
19. KEY WORDS (Continue on reverse side if necessary and identify by block number) CO Laser                      Laser Propagation Water Vapor                  Infrared Spectroscopy Molecular Absorption      Atmospheric Transmittance Spectrophone Opto Acoustic Cell		
20. ABSTRACT (Continue on reverse side if necessary and identify by block number) Previous reports have presented measurements of water vapor absorption coefficients for those CO laser lines which are least attenuated by the atmosphere. This report gives measurements for two CO laser lines [1837.436/cm <sup>-1</sup> , 11-10 P (12) and 1872.236/cm <sup>-1</sup> , 9-8 P (16)] which are highly attenuated by water vapor. Although these CO lines are not likely to be useful in systems which transmit through the atmosphere the results are important nevertheless as is discussed in the report.		

DD FORM 1 JAN 73 1473

EDITION OF 1 NOV 65 IS OBSOLETE

UN CLASSIFIED

SECURITY CLASSIFICATION OF THIS PAGE (When Data Entered)

## FOREWORD

This report, Ohio State University Research Foundation Report Number 3271-6 (sixth Quarterly Report), was prepared by The Ohio State University ElectroScience Laboratory, Department of Electrical Engineering at Columbus, Ohio. Research was conducted under Contract F30602-72-C-0016. Mr. James W. Cusack, RADC (OCSE), of Rome Air Development Center, Griffiss Air Force Base, New York, is the Project Engineer.

## ABSTRACT

Previous reports have presented measurements of water vapor absorption coefficients for those CO laser lines which are least attenuated by the atmosphere. This report gives measurements for two CO laser lines [ $1837.436\text{ cm}^{-1}$ , 11-10 P(12) and  $1872.236\text{ cm}^{-1}$ , 9-8 P(16)] which are highly attenuated by water vapor. Although these CO lines are not likely to be useful in systems which transmit through the atmosphere the results are important nevertheless as is discussed in the report.

## TABLE OF CONTENTS

	Page
I. INTRODUCTION	1
II. COMPARISON OF CALCULATED AND MEASURED ABSORPTION COEFFICIENTS FOR WATER VAPOR-NITROGEN MIXTURES AT A HIGHLY ABSORBED CO LASER FREQUENCY [1837.436 $\text{cm}^{-1}$ 11-10 P(12)]	2
III. EXPERIMENTAL AND CALCULATED RESULTS FOR THE 9-8 P(16) CO LINE [1873.236 $\text{cm}^{-1}$ ]	11
REFERENCES	15

## I. INTRODUCTION

Previous reports[3,6] have reported the search for the CO laser frequencies having the lowest absorption coefficients in water vapor-nitrogen mixtures. Table I of Reference [6] listed 53 CO lines in

TABLE I  
COMPUTED ABSORPTION COEFFICIENTS AT  $1837.436 \text{ cm}^{-1}$   
FOR VARIOUS CONDITIONS AS NOTED

NEAR WATER LINE	k ( $\text{km}^{-1}$ )	LINE SHAPE	ENTRY	COMMENT
1837.200	67.5	Lorentz	a	original table values
1837.200	55.4	OSU	b	
1837.185	62.06	Lorentz	c	measured Rao position
1837.185	61.16	OSU	d	
1837.185	15.29	Lorentz	e	background only
1837.185	16.31	OSU	f	
1837.185	46.77	Lorentz	g	one H <sub>2</sub> O line only
1837.185	44.85	OSU	h	one H <sub>2</sub> O line only

$$P_{\text{H}_2\text{O}} = 5 \text{ torr} \quad P = 745 \text{ torr}$$

$$B = 5 \quad \text{BOUND} = 25 \text{ cm}^{-1}$$

$$\text{BX} = \quad \text{CX} =$$

$$\text{FOR OSU SHAPE: } \nu_m = 3; \quad n = 1.77$$

$$\text{Note} \quad \begin{aligned} c &= e + g \\ d &= f + h \end{aligned}$$

order of their expected transmittance as computed using the Calfee-Benedict line-data tables[1]. Eleven of the most highly transmitting lines (Nos. 1,2,4,6,8-13, and 18 of Table I) were studied experimentally and reported in Reference [6].

This report presents experimental data for lines 28 [ $1873.236 \text{ cm}^{-1}$  9-8 P(16)] and 50 [ $1837.436 \text{ cm}^{-1}$  11-10 P(12)].

The present study was undertaken to compare the multiple traversal absorption cell and the laser irradiated spectrophone techniques. Also the additional data is useful in further developing the comparison between the actual absorption coefficients and those which are predicted by computations from the line-data tables.

II. COMPARISON OF CALCULATED AND MEASURED ABSORPTION  
COEFFICIENTS FOR WATER VAPOR-NITROGEN MIXTURES AT  
A HIGHLY ABSORBED CO LASER FREQUENCY  
[1837.436  $\text{cm}^{-1}$  11-10 P(12)]

Very few accurate water vapor absorption coefficient measurements at infrared laser frequencies are currently available. Further, measurements made by different workers are often in disagreement. The experiment described here was undertaken to show that absorption data taken by using different experimental methods (multitraversal White cell and laser irradiated spectrophone) can yield equivalent results. Finally the measured results are compared to "synthetic spectrum" calculations using the Benedict-Calfee[1] line data tables. The experimental results are also compared with those obtained by D.K. Rice using yet a third method.

The laser frequency selected for study was the 11-10 P(12) line of CO which was assumed to have a frequency of 1837.436  $\text{cm}^{-1}$ . This frequency was computed using the latest molecular constants by Rao[3]. The laser source was a highly stabilized CO laser with grating line selection which was designed by Dr. Charles Freed of MIT Lincoln Laboratory.

Figure 1 shows a transmittance plot which was computed using the Benedict-Calfee tables. As noted on the figure the water vapor pressure was 5 torr, the total pressure 745 torr, the temperature was 73°F, and the path length was 12 meters. Other parameters used in the calculation[4] were: BOUND = 25  $\text{cm}^{-1}$ ; BX = 1.5; CX = .62; and B = 5. A Lorentz line shape was used. It can be seen from Fig. 1 that the parameters of the strong water vapor line at approximately 1837.2  $\text{cm}^{-1}$  will have a strong influence on the computed transmittance. For this reason additional data concerning the frequency of this line was sought from Professor Rao[5]. He reported the frequency to be 1837.1854  $\text{cm}^{-1}$  compared to the value 1837.200 listed in the Benedict-Calfee tables. Calculations were made with both these values for the frequency of the close water line. The remaining line-data was unaltered. Also a computation was made with this line removed to obtain a value for the background. Table I lists the results of this computation. The computations were made with two line shapes. They were the conventional Lorentz and the Ohio State University shape as described in a recent report[6]. The Ohio State University shape has an enhanced wing contribution but it can be seen from Table I that this has only a minor effect on the calculated results in this region. This is in contrast to the results reported in Reference [6] for the highly transmitting CO lines where the line shape had a large effect on the calculated absorption coefficients. From the entries in Table I it can be seen that approximately 75% of the calculated absorption at 1837.436  $\text{cm}^{-1}$  is caused by the single water line at 1837.185  $\text{cm}^{-1}$  with the remaining 25% caused by the other water lines within 25  $\text{cm}^{-1}$  of the laser frequency.

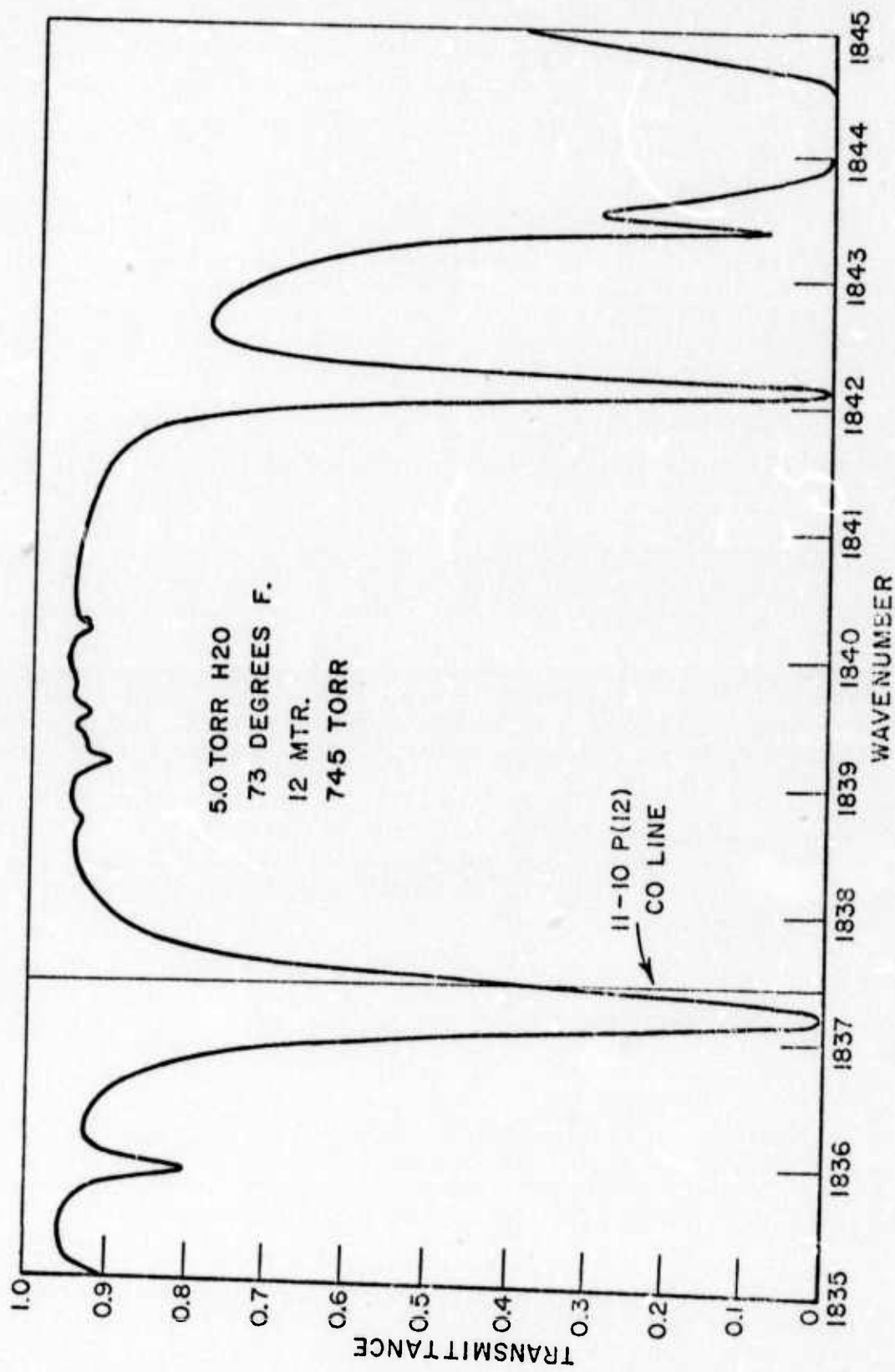

Fig. 1. Calculated water vapor absorption spectrum near  $1837 \text{ cm}^{-1}$ .

Two experiments were then performed to see if these calculated results could be confirmed. One used a multi-traversal absorption cell and the other used a laser irradiated spectrophone technique. The first experiment used a Perkin-Elmer model 193 one meter White cell set for 12 traversals, i.e., a path length of 12 meters. The water vapor pressure was measured using a Cambridge Systems model 880 condensation type dew point hygrometer. The hygrometer had previously been calibrated by comparison to measurements made with a mercury micro-manometer. The complete calibration procedure is described in a separate Reference [7]. During the experiment the sensor head of the hygrometer was in series with a small pump and the absorption cell. The pump maintained the proper flow rate to the sensor head and also aided in mixing the water vapor-nitrogen sample in the absorption cell. The laser radiation was detected with Eppley thermopiles which were connected to amplifiers and an XDS-920 laboratory computer. Figure 2 is a schematic diagram of the experimental arrangement. A similar measurement system has been described in detail in an earlier report[6]. The total pressure in the absorption cell was measured using a one meter Hg manometer. The equipment was arranged so that the room air path lengths from chopper to reference detector and from chopper to signal detector were equal to within one centimeter in order to reduce effects of room air humidity changes on the results.

The cell was first evacuated and the background ratio of signal voltage to reference voltage was measured. Water vapor was then admitted to the cell. The signal to reference ratio was monitored until the transmittance with pure water vapor was approximately 60%. From previous runs it was known that this would be equivalent to 15-16 torr water vapor. Filling the cell with water vapor took approximately 5 minutes. Dry nitrogen was then admitted to the cell until a total pressure of 760 torr was reached. Next the hygrometer pump was turned on and the mixture was allowed to circulate past the sensor head for about fifteen minutes. For at least the last five minutes of that period the dew point temperature was observed to remain constant. After the 15 minute period the dew point temperature was recorded, the pump was turned off, and the signal to reference ratio was measured. Then a portion of the sample was pumped out of the cell and the cell was again filled to 760 torr with dry nitrogen. Then the dew point sensor pump was again turned on and after fifteen minutes the dew point of the new sample and the signal to reference ratio were recorded. This procedure was repeated in order to obtain points on a curve of absorption coefficient versus water vapor pressure. The entire experiment took about four hours to complete.

Figure 3 and Table II show the experimental results of both this experiment and those obtained with the spectrophone. A total of thirteen points were obtained with the White cell, five on 30 March 1973 and eight on 1 April 1973. An additional eight points were obtained with the spectrophone.

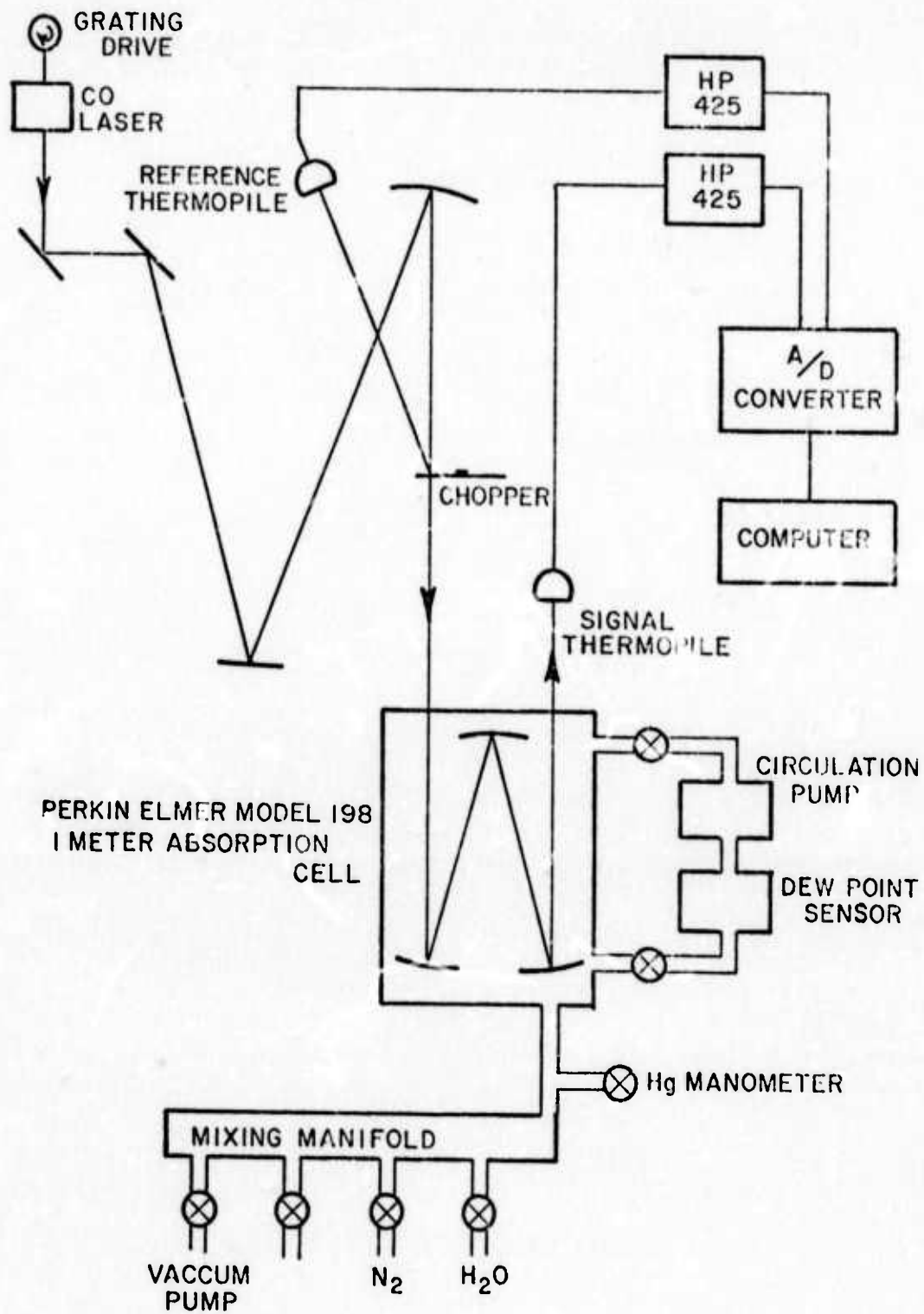

Fig. 2. Schematic diagram of the White cell experiment.

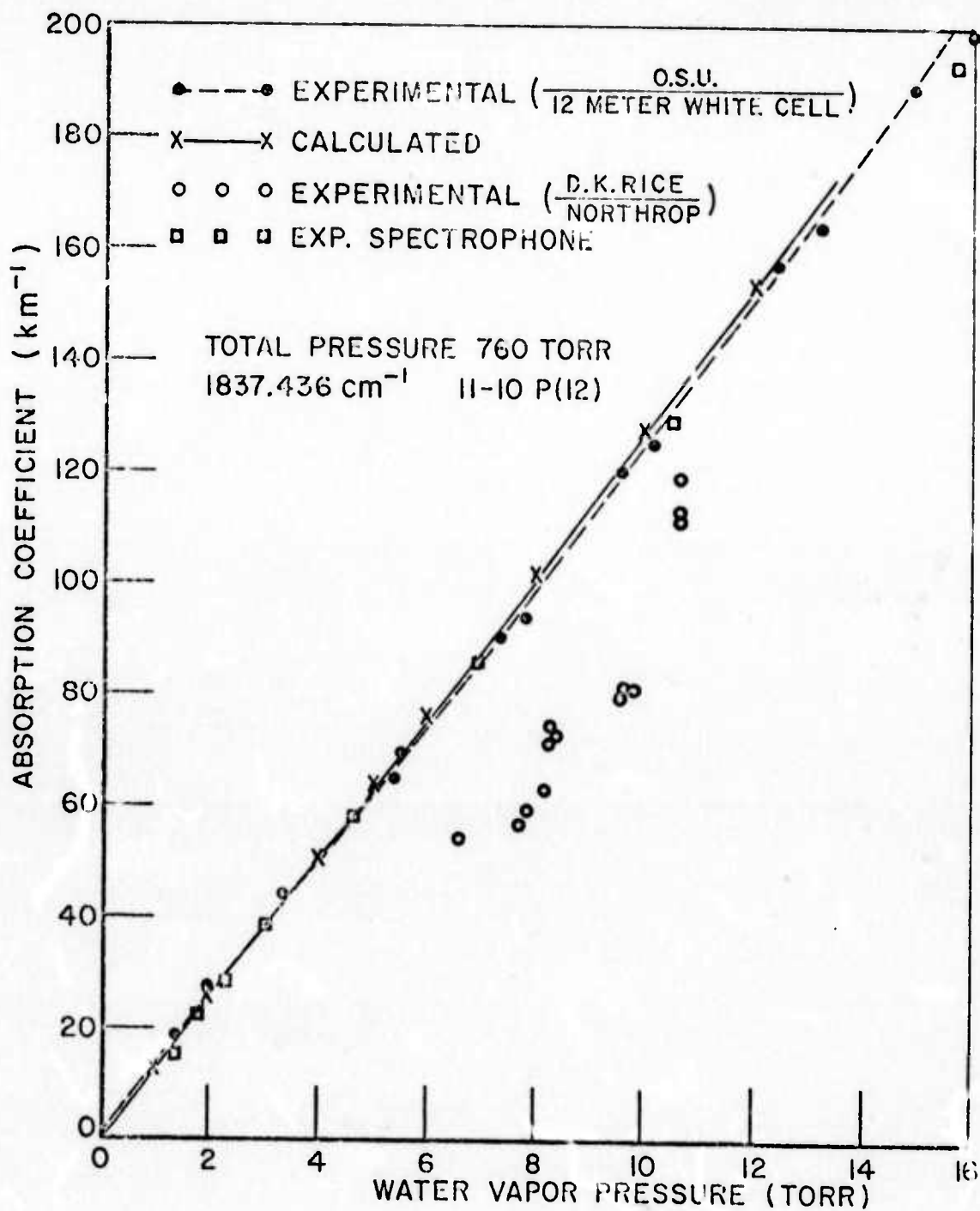

Fig. 3. Measured and calculated data for water vapor absorption coefficient at  $1837.436 \text{ cm}^{-1}$ .

TABLE II  
 COMPARISON OF CALCULATED AND MEASURED ABSORPTION COEFFICIENTS AT  
 $1837.436 \text{ cm}^{-1}$ . SEE TEXT FOR DISCUSSION OF CALCULATED RESULTS

$P_{\text{H}_2\text{O}}$ Torr	$k_{\text{meas}}$ $\text{km}^{-1}$	Code (see below)	$k_{\text{calc}}$ Lorentz 1837.185 B=5	$k_{\text{calc}}$ Lorentz 1837.200 B=5	% Diff Measured and Calc(1837.185)
1.37	17.1	S	17.	18.5	.6
1.4	18.4	12B	17.4	18.9	5.4
1.8	22.3	S	22.3	24.3	0
2.0	26.4	12B	24.8	27.0	6.1
2.32	28.7	S	28.6	31.1	.3
3.06	38.8	S	38.6	42.	.5
3.4	43.5	12B	42.4	46.1	2.5
4.6	57.9	S	57.5	62.6	.7
5.4	64.2	12A	67.5	73.6	5.3
5.5	69.6	12B	68.9	75	1.
6.9	86.1	S	86.8	94.4	.8
7.3	90.1	12B	91.9	100.	2.
7.8	93.4	12A	98.3	107.	5.2
9.6	120.1	12B	121.6	132.3	1.2
10.2	125	12A	129.4	140.8	3.5
10.5	129	S	133.3	145.	3.3
12.4	157.4	12B	158.1	172.	.4
13.2	164	12A	168.7	183.6	2.9
14.9	189.2	12B	191.2	208.	1.1
15.7	193	S	201.9	219.7	4.6
16.	199	12A	205.9	224.	3.5

Code: 12 Meter Cell, 30 March 1973 - 12A  
 12 Meter Cell, 1 April 1973 - 12B  
 Spectrophone, - S

Additional discussion of the results is given after a discussion of the spectrophone equipment.

Recent investigations at The Ohio State University[8] have shown that a laser irradiated spectrophone of simple construction can provide accurate measurements of infrared absorption coefficients. Although this method has received most attention with respect to the measurement of small absorption coefficients it is, of course, equally useful in situations of large absorption. An adequate pressure signal always involves both the absorption and the available laser power. In the present case the available laser power was 50 mW and it was found possible to easily measure the smallest absorption coefficients which were encountered.

Figure 4 shows a diagram of the spectrophone equipment. The spectrophone cell is of a relatively simple design. The cell consists of a 43 cm long piece of 1-1/2 inch aluminum round bar stock which has a 3/8 hole bored lengthwise. The end windows were NaCl flats 5 mm thick and were vacuum sealed with O-rings. A side port near the center allowed attachment of the differential pressure sensor, a CGS Datametrics model 523-15 capacitive manometer (Barocel). This device is not as sensitive as some microphone sensors which have been used in spectrophone work but it was determined that the lower limit of absorption detection even with one watt laser power was due to the false pressure signal which arises from absorption at the end windows and not to the pressure sensor sensitivity.

Another side port near one end was for attaching a leak valve which allowed an equilibrium pressure to be obtained. In operation the leak valve was set at a very small leak rate such that the time constant of the pressure signal was many times longer to the back of the sensor than to the front.

The vacuum system consisted of a small roughing pump and an 8 e/S Vacion pump. A pressure of  $2 \times 10^{-6}$  torr could be obtained. All lines were made of metal to assure that the system would remain free of water. Heating tape wrapped around the cell provided a modest bakeout capability.

Difficulty was encountered with adsorption of water vapor to the walls of the cell which, with time, reduced the partial pressure to a lower and unknown value. To alleviate this problem the arrangement shown in Fig. 4 was used. A water vapor-nitrogen mixture was allowed to flow through the spectrophone cell in series with a small reservoir tank, a circulation pump, a flowmeter, and a Cambridge Systems model 880 dew point hygrometer. After allowing the mixture to circulate for a few minutes the valves to the cell were closed and a measurement of the absorption coefficient taken. The partial pressure of H<sub>2</sub>O was computed from the dew point just as in the multi-traversal cell experiment. The system was first filled with a mixture having a large concentration of water vapor. The successive measurements were taken by partially evacuating the system and refilling to 760 torr with nitrogen, thus reducing the partial pressure to a lower value.

The BaF<sub>2</sub> lens (f.l. = 30 cm) collimated the laser beam so that it did not contact the spectrophone cell walls.

The quantities measured in the experiment were the pressure signal level from the output of the Barocel (using the PAR 128) and the laser power level. The output of the Barocel is 1 volt full scale for any given range. The range chosen was one that was high enough to prevent excessive dc drift due to ambient temperature fluctuations. The PAR then detected the small ac pressure signal which was superimposed on the

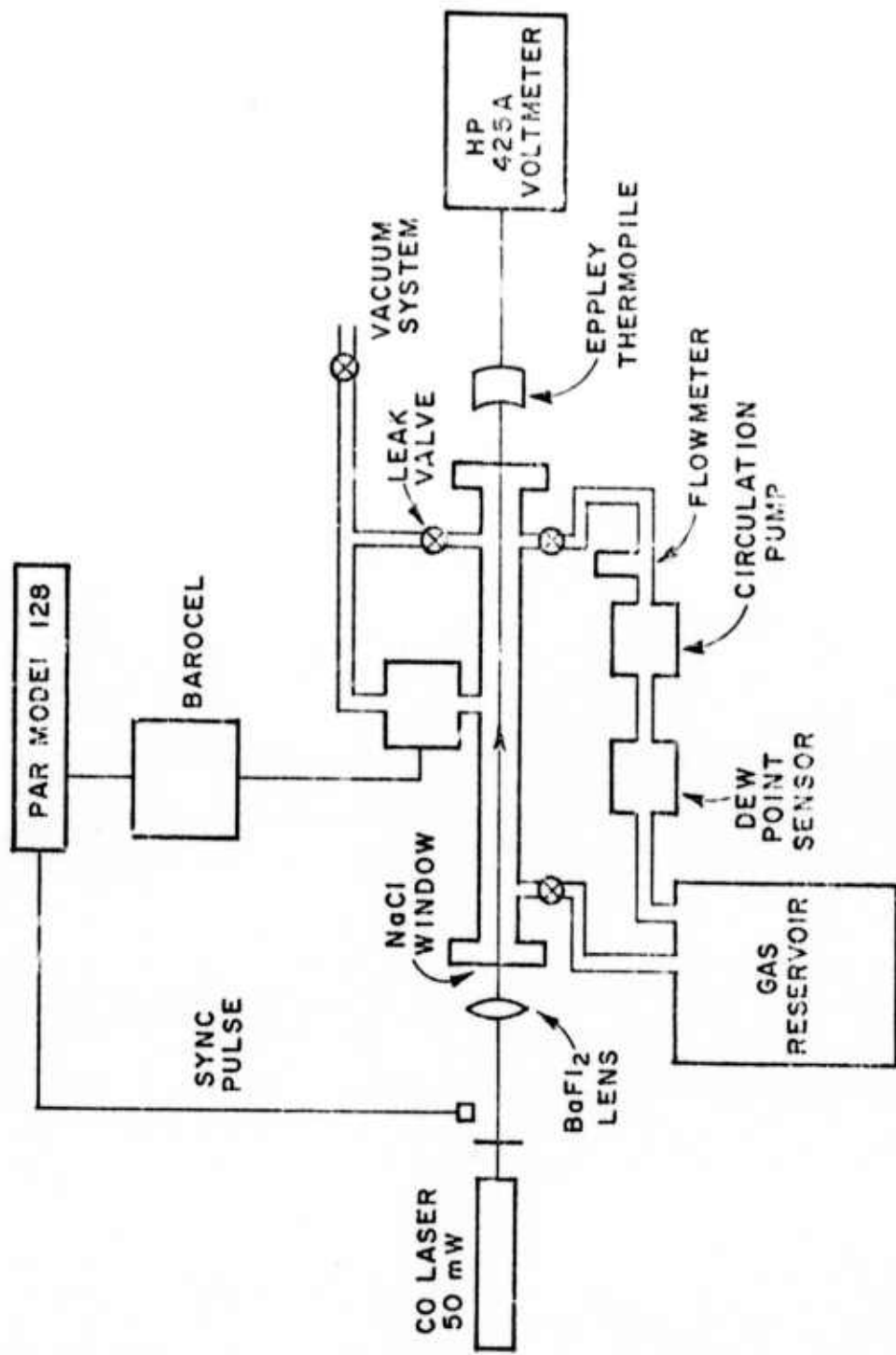

Fig. 4. Schematic diagram of laser irradiated spectrophone apparatus.

larger dc level. The absorption coefficient is proportional to the ratio of the pressure signal and the laser power. The pressure signal is also a function of temperature and total pressure but these remained unchanged during the set of measurements. The proportionality constant for the absorption coefficient is found by measuring a known absorption under conditions similar to those of the desired measurement.

In reducing the spectrophone data a background signal equivalent to an absorption coefficient of  $3.3 \text{ km}^{-1}$  was subtracted from the measured signal. It should be noted that the background signal would have been smaller if new windows had been used. Also when the absorption coefficient to be measured is smaller a greater laser power is needed in order to obtain an adequate pressure signal. However, the advantage gained by the increased laser power is diminished somewhat by the larger window signal at the higher power.

For this experiment the known absorbing medium was a mixture of near 2 torr ethylene with nitrogen added to a total of 1 atmosphere. The small partial pressure of ethylene means that the conductivity properties of the ethylene-nitrogen calibrating gas will be similar to those of the water vapor-nitrogen mixture. The transmittance through this mixture at the line of interest was approximately 72% as measured in the 12 meter White cell equipment described previously. This level of absorption is considered to be an accurate region for measurements using the White cell technique.

To increase confidence in the knowledge of the quantity of ethylene in the mixtures in the White cell and the spectrophone, the same micrometric manometer was used to measure the pressure during both filling procedures. It is noted that by connecting the White cell and the spectrophone to give a common gas mixture the micrometric manometer would not even be required.

It may appear trivial that the results of the measurements of water vapor using the two techniques were so similar since the White cell was used to calibrate the spectrophone. However the main point of suspicion in the White cell measurements of water vapor has been that this gas is not well behaved under many circumstances. In particular it has been suggested that condensation on the White cell mirrors at high concentrations might give an apparent larger absorption. Since ethylene is not expected to ill behave in this manner the results show that the suspected condensation of water vapor does not occur at the concentrations measured. Furthermore for small absorptions the spectrophone directly determines absorption whereas the White cell measures transmittance by subtracting nearly equal numbers so that the precision of the spectrophone technique is greater. Thus the best method for determining small water vapor absorption coefficients may be to use a spectrophone

which has been calibrated using another gas and a White cell as described here. For these more sensitive measurements we have a 15 meter White cell with path lengths up to one km.

Referring again to Table II and Fig. 3 it is seen that there is a close correspondence between the water vapor absorption coefficients measured using the White cell and the spectrophone. Also the "synthetic spectrum" calculation using Lorentz line shape and conventionally accepted values for the various calculation parameters[4] yields a result in excellent agreement with measurement. Table II also shows the extent of the inaccuracy introduced by the use of the original value for the frequency of the nearest water line.

For laser frequencies located in the atmospheric windows near  $5\mu$  we have previously shown that calculation and measurement are in substantial disagreement[6] apparently due to the greater importance of line shape in the latter calculation.

In Fig. 3 we also have shown the measured points obtained by Rice and referred to in the introduction[2]. We conclude that these results, which have considerable scatter, are probably less accurate. We are not in a position to assess the most probable reason but could speculate that it may involve the short path length (1 meter) or the water vapor measurement method which Rice used. For 8 torr pressure Rice measured  $k = 60 \text{ km}^{-1}$  or a transmittance of 94% on a one meter path whereas we measured  $k = 100 \text{ km}^{-1}$  on a 12 meter path or a transmittance of 30%.

### III. EXPERIMENTAL AND CALCULATED RESULTS FOR THE 9-8 P(16) CO Line [ $1872.236 \text{ cm}^{-1}$ ].

The Freed CO laser which was used for these studies is unable to resolve some of the more closely spaced lines. In some cases one of the line pairs may be enhanced by proper setting of the grating and the piezoelectric end mirror position voltage. An external etalon would have been useful but was not available.

This section presents data obtained for one of the blended line pairs. In this case measurement with a high resolution spectrometer was used to determine that 96% of the laser power was on the 9-8 P(16) line at  $1872.236 \text{ cm}^{-1}$  while the remaining 4% was on the 10-9 P(10) line at  $1870.620 \text{ cm}^{-1}$ .

Figure 5 shows the computed water vapor absorption spectrum for this region. The water vapor pressure was 5.8 torr, the path length 12 meters, and the total pressure 760 torr. A Lorentz line shape was used. It is seen that the  $1872.236 \text{ cm}^{-1}$  line is in a transmission window in that it is located several line widths from the nearest

5.8 TORR H<sub>2</sub>O. 73 DEG F. 12 MTR. 760 TORR

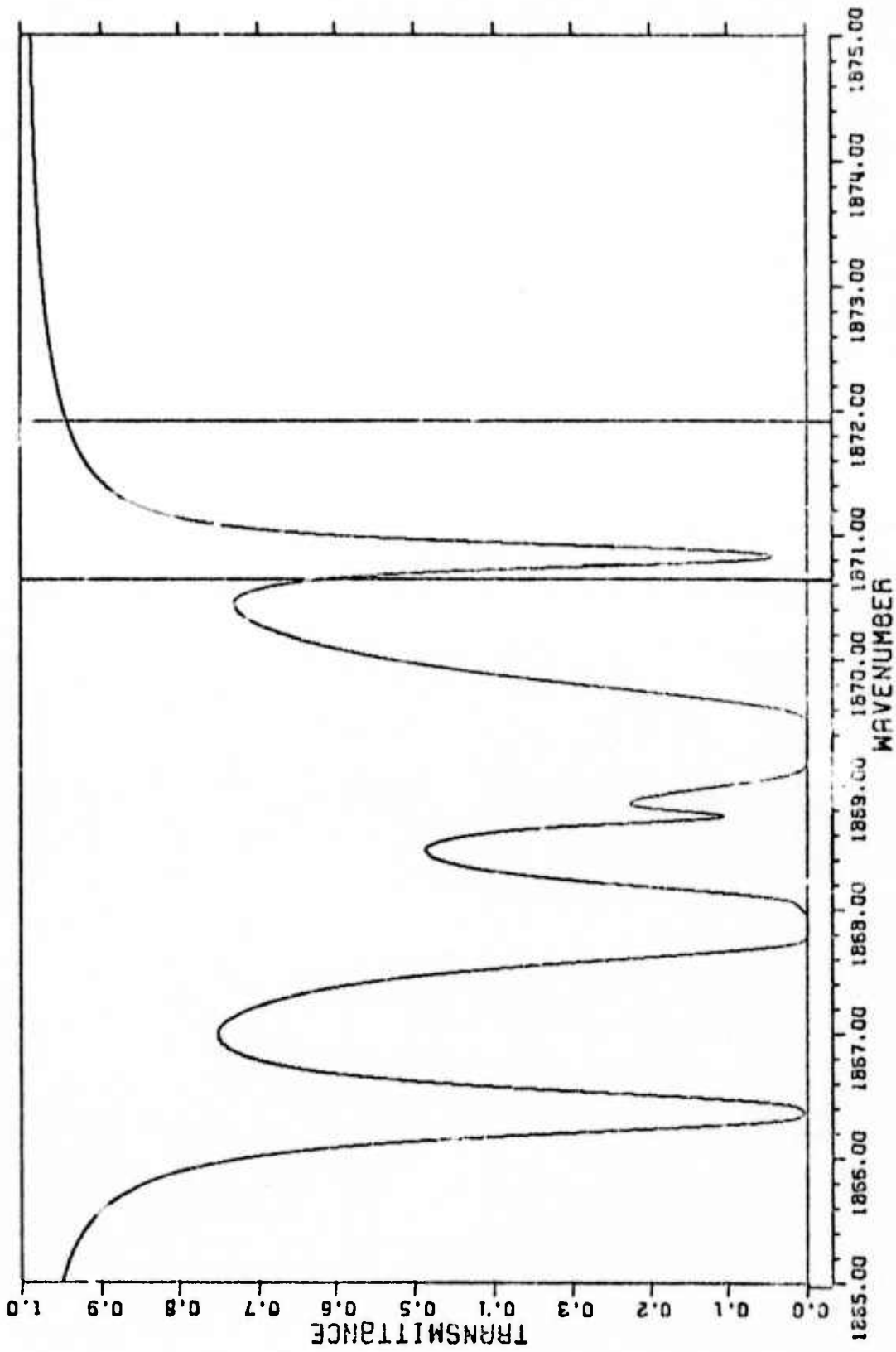

Fig. 5. Calculated transmittance 1865-1875  $\text{cm}^{-1}$  for 5.8 torr H<sub>2</sub>O at 760 torr total pressure.

absorption line. However, the predicted absorption coefficient is 2.6 times as large as the most highly absorbing line reported in Table I of Reference [6]. It was decided to conduct the measurement to see whether the pattern observed for the highly transmitting window lines would be observed here also. In those cases the calculated absorption coefficient using the Lorentz line shape was low by as much as 50%.

Figure 6 shows the experimental data. The absorption of laser energy when the power is distributed between several frequencies can be described by

$$(1) \quad T = e^{-k_c \ell}$$

$$(2) \quad k_c = \sum_{i=1}^N P_i k_i$$

where  $k_i$  is the absorption coefficient at frequency  $\nu_i$  and the fraction of the total laser power at frequency  $\nu_i$  is  $P_i$ . The composite coefficient is  $k_c$ . Using this approach the composite absorption coefficient was computed using a Lorentz line shape and also using the previously discussed "Ohio State University shape"[6]. Both results are shown in Fig. 6. No attempt was made to adjust the parameters in the OSU line shape in order to improve the agreement.

The results are consistent with those previously reported for more highly transmitting lines[6].

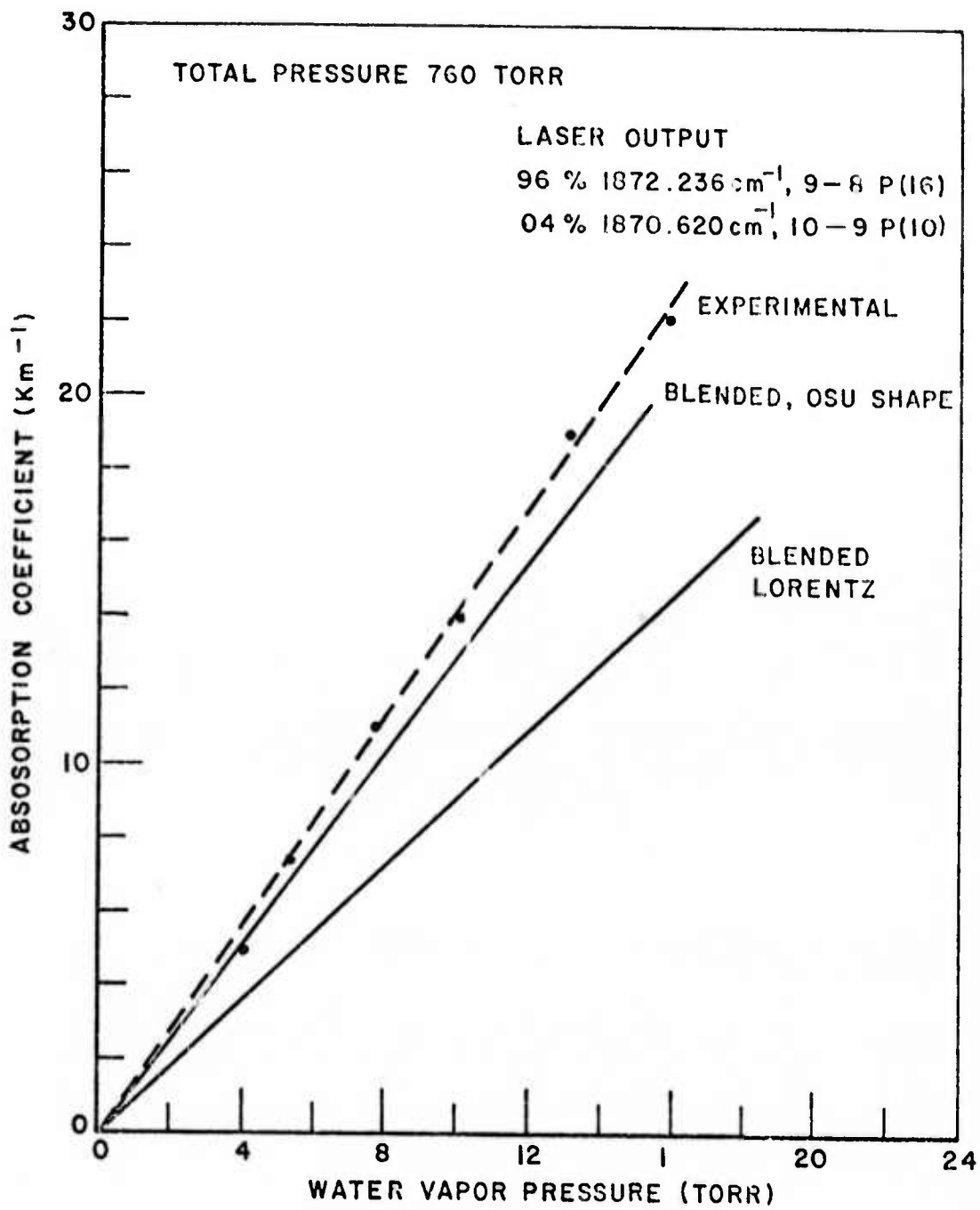

Fig. 6. Experimental absorption coefficients for  $1872.236 \text{ cm}^{-1}$  CO laser line compared with computed values.

## REFERENCES

1. Benedict, W.S. and Calfee, R.F., "Line Parameters for the 1.9 and 6.3 Micron Water-Vapor Bands," ESSA Professional Paper No. 2, 1967.
2. Rice, D.K., "Atmospheric Attenuation Measurements for Several Highly Absorbed CO Laser Lines," submitted to applied Optics, 1973.
3. Mantz, Watson, Rao, Albritton, Schmeltekopf, and Zare, J. Molec. Spec., Vol. 39, No. 1, July 1971, p. 180.
4. Ford, D.L., Mills, F.S. and Long, R.K., "Laser Absorption in the 5 Micron Band," Report 3271-3, July 1972, The Ohio State University ElectroScience Laboratory, Department of Electrical Engineering; prepared under Contract F30602-72-C-0016 for Rome Air Development Center. (RADC-TR-720195) (AD 748 437)
5. Rao, K.N. and Yin, P.K.L., Private Communication.
6. Long, R.K., Mills, F.S. and Trusty, G.L., "Experimental Absorption Coefficients for Eleven CO Laser Lines," Report 3271-5, March 1973, The Ohio State University ElectroScience Laboratory, Department of Electrical Engineering; prepared under Contract F30602-72-C-0016 for Rome Air Development Center.
7. Mills, F.S. and Trusty, G.L., "Simplified Calibration Procedures for Dew Point Hygrometers," to be published.
8. Trusty, G.L., "Absorption Measurements of the 10.4 Micron Region Using a CO<sub>2</sub> Laser and a Spectrophone," Report 2819-4, January 1973, The Ohio State University ElectroScience Laboratory, Department of Electrical Engineering; prepared under Contract F33615-69-C-1807 for Air Force Avionics Laboratory. (AFAL-TR-72-413) (AD 907 549)