

AD-766 681

MECHANICAL PROPERTIES AND FRACTURE TOUGHNESS OF
Ti-6Al-2Sn-4Zr-2Mo

ARMY MATERIALS AND MECHANICS RESEARCH CENTER

PREPARED FOR
ARMY MATERIEL COMMAND

MAY 1973

DISTRIBUTED BY:

NTIS

National Technical Information Service
U. S. DEPARTMENT OF COMMERCE

AMMRC TR 73-23

AD

AD 76681

MECHANICAL PROPERTIES AND
FRACTURE TOUGHNESS OF
Ti-6Al-2Sn-4Zr-2Mo

CHARLES F. HICKEY, Jr., and THOMAS S. DeSISTO
METALS RESEARCH DIVISION

May 1973

Approved for public release; distribution unlimited.

Reproduced by
NATIONAL TECHNICAL
INFORMATION SERVICE
U.S. Department of Commerce
Springfield, VA. 22151

DDC
RECEIVED
SEP 17 1973
RECEIVED
B

ARMY MATERIALS AND MECHANICS RESEARCH CENTER
Watertown, Massachusetts 02172

ACCESSION for	
NTIS	Write Section <input checked="" type="checkbox"/>
DEC	E. O. S. Item <input type="checkbox"/>
UNANNOUNCED	<input type="checkbox"/>
JUSTIFICATION	
BY	
DISTRIBUTION/AVAILABILITY CODES	
Dist.	AVAIL. and/or SPECIAL
A	

The findings in this report are not to be construed as an official Department of the Army position, unless so designated by other authorized documents.

Mention of any trade names or manufacturers in this report shall not be construed as advertising nor as an official indorsement or approval of such products or companies by the United States Government.

DISPOSITION INSTRUCTIONS

Destroy this report when it is no longer needed.
Do not return it to the originator.

DOCUMENT CONTROL DATA - R & D

(Security classification of title, body of abstract and indexing annotation must be entered when the overall report is classified)

1. ORIGINATING ACTIVITY (Corporate author) Army Materials and Mechanics Research Center Watertown, Massachusetts 02172		2a. REPORT SECURITY CLASSIFICATION Unclassified	
		2b. GROUP	
3. REPORT TITLE MECHANICAL PROPERTIES AND FRACTURE TOUGHNESS OF Ti-6Al-2Sn-4Zr-2Mo			
4. DESCRIPTIVE NOTES (Type of report and Inclusive dates)			
5. AUTHOR(S) (First name, middle initial, last name) Charles F. Hickey, Jr., and Thomas S. DeSisto			
6. REPORT DATE May 1973		7c. TOTAL NO. OF PAGES 14	7d. NO. OF REFS 7
8a. CONTRACT OR GRANT NO.		9a. ORIGINATOR'S REPORT NUMBER(S) AMMRC TR 73-23	
b. PROJECT NO. D/A 1T062105A328			
c. AMCMS Code 612105.11.294		9b. OTHER REPORT NO(S) (Any other numbers that may be assigned this report)	
d. Agency Accession Number DA OD4766			
10. DISTRIBUTION STATEMENT Approved for public release; distribution unlimited.			
11. SUPPLEMENTARY NOTES		12. SPONSORING MILITARY ACTIVITY U. S. Army Materiel Command Alexandria, Virginia 22304	
13. ABSTRACT The purpose of this program was to obtain mechanical property and toughness parameter data for Ti-6Al-2Sn-4Zr-2Mo in two heat-treated conditions. Solution temperatures of 1650 and 1790 F followed by an aging treatment at 1100 F were selected. Variables considered include specimen location and orientation, plus notch orientation for the toughness specimens. Light microscopy, X-ray, and fatigue crack growth patterns were also studied and correlated with the above parameters. The most significant finding in this investigation was the enhancement in toughness parameter data with increased heat treatment temperature. Impact and precracked Charpy (W/A) values were approximately doubled and plane-strain fracture toughness values were increased roughly 17%. (Authors)			

14 KEY WORDS	LINK A		LINK B		LINK C	
	ROLE	WT	ROLE	WT	ROLE	WT
Titanium alloys Microstructure Heat treatment Mechanical properties Fracture toughness Impact Anisotropy						

AMMRC TR 73-23

MECHANICAL PROPERTIES AND FRACTURE TOUGHNESS OF Ti-6Al-2Sn-4Zr-2Mo

Technical Report by
CHARLES F. HICKEY, Jr., and THOMAS S. DeSISTO

May 1973

D/A Project 1T062105A328
AMCMS Code 612105.11.294
Metals Research for Army Materiel
Agency Accession Number DA OD4766

Approved for public release; distribution unlimited.

METALS RESEARCH DIVISION
ARMY MATERIALS AND MECHANICS RESEARCH CENTER
Watertown, Massachusetts 02172

AMMRC Ex. O. 33A04

ARMY MATERIALS AND MECHANICS RESEARCH CENTER

MECHANICAL PROPERTIES AND FRACTURE TOUGHNESS OF Ti-6Al-2Sn-4Zr-2Mo

ABSTRACT

The purpose of this program was to obtain mechanical property and toughness parameter data for Ti-6Al-2Sn-4Zr-2Mo in two heat-treated conditions. Solution temperatures of 1650 and 1790 F followed by an aging treatment at 1100 F were selected. Variables considered include specimen location and orientation, plus notch orientation for the toughness specimens. Light microscopy, X-ray, and fatigue crack growth patterns were also studied and correlated with the above parameters.

The most significant finding in this investigation was the enhancement in toughness parameter data with increased heat treatment temperature. Impact and precracked Charpy (W/A) values were approximately doubled and plane-strain fracture toughness values were increased roughly 17%.

INTRODUCTION

Titanium alloys are assuming an ever-increasing role in aircraft systems. Although the Ti-6Al-4V has been and still is the "work horse" of the titanium family, newer alloys such as Ti-6Al-2Sn-4Zr-2Mo are now assuming greater importance. This material is a super-alpha titanium alloy and is characterized by excellent creep resistance and stress stability to 1050 F. It is currently being used in jet engine compressor parts and airframe skin components.

Titanium Metals Corporation of America developed Ti-6Al-2Sn-4Zr-2Mo and their personnel have authored several publications dealing with its mechanical properties at room and elevated temperatures.¹⁻³ A review of the literature reveals that there is little, if any, fracture toughness data available for Ti-6Al-2Sn-4Zr-2Mo. Thus, in an effort to more fully characterize this alloy, the authors have evaluated its plane-strain fracture toughness properties. Tensile, Charpy impact, and precracked Charpy toughness data and microstructural variations are presented in this report.

MATERIAL AND PROCEDURE

The material was supplied by Titanium Metals Corporation of America in the form of 2 x 4-1/2 x 12-inch rectangular bar. The chemical composition as determined by the supplier is shown in Table I. The alloy was tested in an as-received heat-treated condition and also after an in-house heat treatment. The heat treatments are defined in Table II. The lower solution temperature (as-received

Table I. CHEMICAL COMPOSITION
(in weight percent)

Al	Sn	Zr	Mo	O	N	C	Fe
5.97	2.04	4.00	1.99	0.08	0.006	0.023	0.076

Table II. HEAT TREATMENT

Condition	Solution Treatment	Aging Treatment
A (as-received)	1650 F - 1 Hr - AC	1100 F - 8 Hr - AC
B	1790 F - 1 Hr - AC	1100 F - 8 Hr - AC

¹*Metallurgical and Mechanical Properties of Titanium Alloy Ti-6Al-2Sn-4Zr-2Mo Sheet, Bar, and Forgings.* TMCA Bulletin, September 1966.

²RUSSELL, H. A. *Long Time Creep-Stability and Low Cycle Fatigue Properties of Ti-6Al-2Sn-4Zr-2Mo (Case Study M-113).* TMCA Bulletin, May 1967.

³RUSSELL, H. A. *Elevated Temperature Properties of Ti-6Al-2Sn-4Zr-2Mo Bar and Forgings (Case Study M-121).* TMCA Bulletin, September 1967.

condition) will be referred to as condition A and the higher solution temperature as condition B. Tension specimens were tested in both the longitudinal and transverse directions. Fracture toughness and Charpy bars were tested in three orientations as defined in Figure 1.

Tension testing using a 0.252-inch-diameter tension bar was conducted on a 60,000-pound hydraulic testing machine. A mark was scribed on the threaded end of the bars parallel to the plate surface, thus providing a reference to measure the thickness and width strain (anisotropy) within each bar. The slow-bend type bar, shown in Figure 2, was used for the plane-strain fracture toughness investigation. Specimen dimensions were $4 \times 1 \times 0.5$ inches. Testing was conducted in accordance with ASTM E 399-70T.⁴ Pre-cracked Charpy toughness (W/A) data were obtained from Charpy V-notch impact specimens which had been fatigue cracked approximately 0.055 inch. The fatiguing operation was conducted on a Sonntag SF-1U fatigue machine and the specimens were broken in a 240-foot-pound Sonntag Charpy machine. The Charpy impact specimens were also broken on this machine.

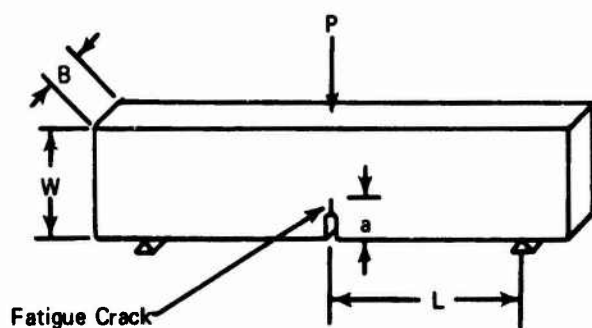
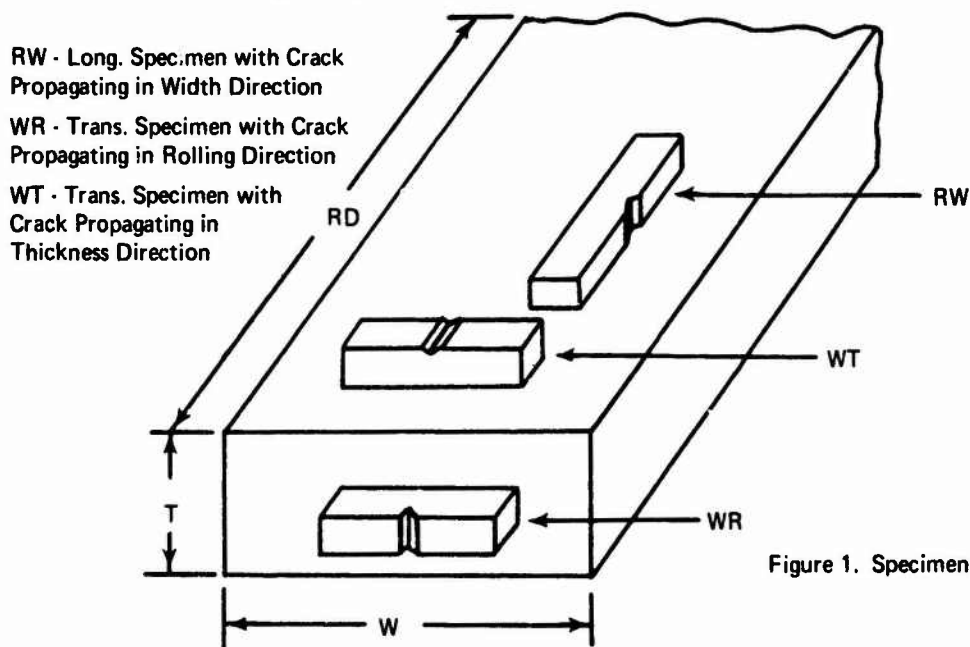

⁴Tentative Method of Test for Plane-Strain Fracture Toughness of Metallic Materials (E 399-70T). ASTM Standards, part 31, July 1971, p. 919-935.

Specimens in condition A were machined from the heat-treated $2 \times 4\text{-}1/2 \times 12$ -inch bar and tested; for condition B the specimens were machined to blank form, heat treated, finish machined, and tested. All testing was conducted at room temperature.

MICROSTRUCTURE

Titanium 6Al-2Sn-4Zr-2Mo is a super- α alloy with a beta transus temperature of $1815 \text{ F} \pm 10^\circ$. Typical micrographs for conditions A and B are shown in Figure 3. There is a significant difference in the appearance between the two conditions. Condition A is characterized by a predominance of blocky-type alpha which is mainly attributed to the processing history of the material. Based on results obtained by standard X-ray diffraction techniques the microstructure of condition A consists of approximately 85% α (primary α + transformed β) plus retained β .

Increasing the solution temperature to 1790 F (condition B) and heat treating specimens in blank form results in a decrease in the amount of primary α plus a significant change in its appearance, Figure 3b. At this higher temperature much of the primary alpha has dissolved and the portion remaining is more equiaxed, although there is still evidence of some blocky-type alpha. X-ray analysis indicates approximately the same α/β ratio as found for condition A, however the α for condition B contains much more transformed β . Hickey and Fopiano⁵ have shown

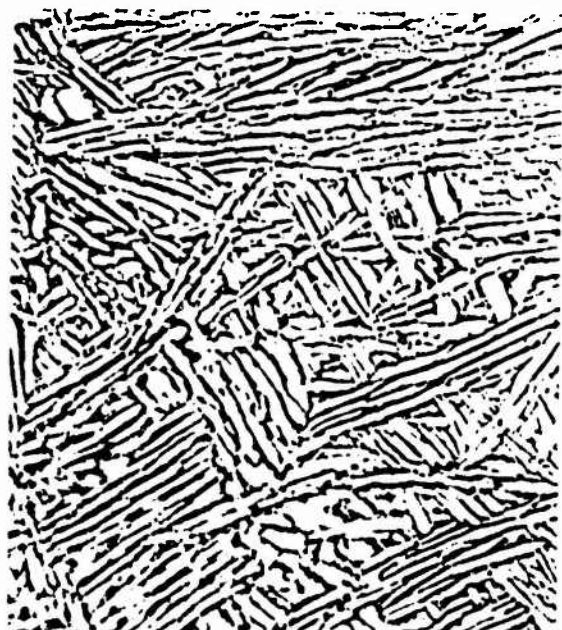

a. Condition A - 1650 F-1hr-AC; 1100 F-8hr-AC



b. Condition B - 1790 F-1hr-AC; 1100 F-8hr-AC

Figure 3. Microscopy of Specimens for Conditions A and B
Etchant: 30 Glycerin, 10 HNO₃, 10 HF. Mag. 500X

⁵HICKEY, C. F., Jr., and FOPIANO, P. J. *Some Observations on the Hardenability of Ti-6Al-6V-2Sn*. ASM Metallurgical Transactions, v. 1, June 1970, p. 1775.

that the nonmartensitic form of transformed β in numerous α - β titanium alloys consists of Widmanstätten α (W- α) + β . The authors feel it to be also true for this alloy. It was not possible to differentiate by X-rays between primary α and (W- α), thus it is concluded that both phases have the same lattice parameter. The (W- α) is needle-like in appearance and in many cases originates at the α - β phase boundary.

RESULTS AND DISCUSSION

Tensile Properties

Tensile properties for conditions A and B are listed in Table III. Outside and center-plate locations for both the longitudinal and transverse directions were considered. In condition A, heat treated in plate form, the longitudinal strength properties are higher in the outside plate than center plate location with no significant difference in ductility. Transverse properties, both strength and ductility, are higher for the outside than center plate location. In condition B, where the specimens were heat treated in blank form, there was little difference between outside and center plate properties for both the longitudinal and transverse orientations.

Final diameter readings were obtained in the thickness and the width directions on the fractured tension bars using a micrometer. Although in some cases the maximum and minimum diameters may not have occurred at precisely these locations, it was established that this alloy, in its investigated conditions, exhibited only a slight degree of anisotropy. For example, the maximum and minimum values of R are 1.4 and 0.84. (R is the ratio of straining in the width versus thickness direction.) Any type of anisotropy trend based upon the test variables (specimen location, orientation, or heat treatment) was not found to exist. All tensile data were based on duplicate tests.

Table III. TENSILE PROPERTIES IN THE HEAT-TREATED CONDITIONS

Condition	Location	Orientation	YS 0.2 % Offset (ksi)	TS (ksi)	Elongation (%)	Reduction of Area (%)
A	O	L	127	137	14.8	32.8
	C	L	122	134	15	32.1
	O	T	127	137	14	27.4
	C	T	119	130	10	21.8
B	O	L	118	136	18.5	27.3
	C	L	119	137	16	27.5
	O	T	125	139	11.5	23.4
	C	T	121	140	10	24

O = Outside Plate Location

C = Center Plate Location

Data represents average of two tests.

A pole figure of the basal plane (0002) was also obtained for both of the conditions. Results indicate only a small degree of preferred crystallographic orientation (texturing), thus confirming the low R values and the small change as a function of orientation. Since texturing is not a factor in this material, property changes as a function of orientation are attributed to microstructural features.

Toughness Properties

Table IV contains Charpy V-notch impact and W/A data as a function of heat treatment and specimen orientation. In contrast to the tensile properties, a large difference exists in toughness properties between conditions A and B. Impact data range from 13.2 to 16.3 ft-lb for condition A and 24.7 to 29.8 ft-lb for condition B. The corresponding range for W/A data is 713 to 1195 in.-lb/in.² and 1440 to 2185 in.-lb/in.². For both conditions the impact and W/A values were greater in the RW orientation than in either the WR or WT orientation. This is expected since in the RW orientation the crack propagates in a direction perpendicular to the elongated type microstructure which was produced by the prior fabrication history of the material. A discussion as to the effect of microstructure on the toughness properties is included later in the report.

Plane-strain fracture toughness values (K_Q) and pertinent test information are presented in Table V as a function of heat treatment and specimen orientation. All conditions specified by E 399-70T⁴ were not met, thus the data are expressed as K_Q . However, the values do represent a qualitative measure of the fracture toughness of this alloy in the investigated conditions. The K_Q values are higher for condition B than for condition A, as was also the case with the impact and W/A data. Average values for the respective conditions ranged from 63 to 73 ksi $\sqrt{in.}$ and from 55.3 to 63 ksi $\sqrt{in.}$. The RW orientation afforded the greatest resistance to crack growth for both conditions and the WT orientation resulted in the lowest K_Q values for both conditions.

Table IV. TOUGHNESS PROPERTIES IN THE HEAT-TREATED CONDITIONS

Condition	Orientation	Impact Energy (ft-lb)*	W/A (in.-lb/in. ²) [†]
A	RW	16.3	1195 [‡]
	WR	13.5	713
	WT	13.2	865
B	RW	29.7	2185
	WR	24.7	1627
	WT	25.1	1440

*Average of two tests

†Average of three tests

‡One test

Table V. FRACTURE TOUGHNESS VALUES IN THE HEAT-TREATED CONDITIONS

Condition	Orientation	Specimen Thickness B, inch	Specimen Width W, inch	Crack Depth A, inch	Fracture Toughness K _Q , ksi√in.	
A	RW	0.503	1.003	0.524	62*†	
	RW	.504	1.001	.494	63*†	
	RW	.506	1.004	.527	64†	
						63 (AVG)
	WR	.504	1.004	.507	51*	
	WR	.502	1.001	.523	68†	
	WR	.505	1.001	.511	56†	
						58.3 (AVG)
	WT	.501	0.971	.489	55*	
WT	.501	1.010	.511	59*†		
WT	.502	1.010	.521	52		
					55.3 (AVG)	
B	RW	0.504	1.001	0.498	71*†	
	RW	.504	1.001	.569	81†	
	RW	.504	1.001	.587	64†	
						72 (AVG)
	WR	.506	1.002	.533	75*†	
	WR	.506	1.001	.555	70†	
	WR	.505	1.001	.523	67*†	
						70.7 (AVG)
	WT	.502	0.982	.501	61*†	
WT	.502	0.971	.538	65*†		
					63 (AVG)	

*Fatigue crack control did not meet E399-71 Criteria

$$†\text{Thickness} < 2.5 \left(\frac{K_Q}{\sigma_{YS}} \right)^2$$

Crack Growth Characteristics

There currently exists a great deal of interest in the effect of microstructure on the toughness properties of titanium alloys. Gerberich and Baker⁶ have shown that the fracture toughness of Ti-6Al-4V can be enhanced by introducing a platelet-like phase of α into a β matrix by a duplex heat treatment (slow cooling from above the β transus, followed by a re-resolution anneal just below the β

⁶GERBERICH, W. W., and BAKER, G. S. *Toughness of Two-Phase 6Al-4V Titanium Microstructure*. ASTM STP 432, ASTM, Philadelphia, 1968, p. 80.

transus). Greenfield and Margolin⁷ have indicated that in Ti-5.25Al-5.5V-0.9Fe-0.5Cu the fracture follows the beta matrix grain boundaries for both an equiaxed alpha-aged beta and Widmanstätten plus grain boundary alpha-aged beta microstructure. They further find that in the latter case an increase in the size of the grain boundary α results in increased fracture toughness.

In this investigation, based upon the toughness data, it is apparent that the microstructure of condition B can tolerate a longer fatigue crack than condition A. However, an examination of the crack growth pattern did not reveal an adequate explanation. Typical fatigue crack growth paths are shown in Figure 4. In condition A, there is a high degree of grain or phase anisotropy. In some cases the crack propagates parallel to the α phase while in other cases the growth is perpendicular or at an angle across the α phase. Crack width with respect to the α phase was large, therefore when the crack did propagate parallel to the α phase it was not possible to determine whether it preferred the α phase or its boundary.

The crack growth path for condition B is shown in Figure 4b. It can be seen that at the higher temperature most of the blocky-type α transforms into an elongated and equiaxed type, plus there is a large increase in the amount of transformed β . Again, the fatigue crack path does not reveal phase preference. It is evident that a more detailed investigation is necessary to define the fatigue crack growth pattern of this alloy.



a. Condition A



b. Condition B

Figure 4. Fatigue Crack Path of Conditions A and B for RW Orientation.
Etchant: 30 glycerin, 10 HNO₃, 10 HF
Mag. 500X

⁷GREENFIELD, M. A. and MARGOLIN, H. *Fracture Toughness and Microstructure in an Alpha-Beta Titanium Alloy*. Presented at the spring meeting of the Metallurgical Society of AIME, May 11-14, 1970, Las Vegas, Nevada.

CONCLUSIONS

1. Increasing the solution temperature from 1650 F (condition A) to 1790 F (condition B) resulted in a small change in the tensile properties and a large increase in toughness. Impact and W/A values were approximately doubled and plane-strain fracture toughness values (K_{Ic}) were increased roughly 17%.

2. Toughness anisotropy was evidenced as a function of specimen and notch orientation. Higher toughness values (impact, W/A, and K_{Ic}) resulted from the RW than from the WR or WT specimen orientation.

3. Based upon the toughness data, the microstructure of condition B can tolerate a longer fatigue crack than that of condition A; however, an examination of the fatigue crack pattern did not reveal an explanation. A detailed investigation is warranted in this area.