

AD-769 482

UNITED STATES AIR FORCE AIRCRAFT
POLLUTION EMISSIONS

Dennis F. Naugle, et al

Air Force Weapons Laboratory
Kirtland Air Force Base, New Mexico

November 1973

DISTRIBUTED BY:

NTIS

National Technical Information Service
U. S. DEPARTMENT OF COMMERCE
5285 Port Royal Road, Springfield Va. 22151

UNCLASSIFIED

Security Classification

DOCUMENT CONTROL DATA - R & D

(Security classification of title, body of abstract and indexing annotation must be entered when the overall report is classified)

AD-769482

1. ORIGINATING ACTIVITY (Corporate author) Air Force Weapons Laboratory (DEE) Kirtland Air Force Base, NM 87117		2a. REPORT SECURITY CLASSIFICATION UNCLASSIFIED	
		2b. GROUP	
3. REPORT TITLE United States Air Force Aircraft Pollution Emissions			
4. DESCRIPTIVE NOTES (Type of report and inclusive dates) 1 January 1973 to 13 July 1973			
5. AUTHOR(S) (First name, middle initial, last name) Dennis F. Naugle, Capt, USAF, BSC Bernard T. Delaney			
6. REPORT DATE November 1973		7a. TOTAL NO. OF PAGES 5451	7b. NO. OF REFS 29
8a. CONTRACT OR GRANT NO.		9a. ORIGINATOR'S REPORT NUMBER(S) AFWL-TR-73-199	
b. PROJECT NO. 19003W06		9b. OTHER REPORT NO(S) (Any other numbers that may be assigned this report)	
c.			
d.			
10. DISTRIBUTION STATEMENT Approved for public release; distribution unlimited.			
11. SUPPLEMENTARY NOTES		12. SPONSORING MILITARY ACTIVITY Air Force Weapons Laboratory (DEE) Kirtland Air Force Base, NM 87117	
13. ABSTRACT (Distribution Limitation Statement A) The interest in pollution emissions from aircraft has been enhanced by Environmental Protection Agency's recent determination that major civilian airports are significant contributors to localized air-quality degradation. This report summarizes the USAF aircraft and engines in common use, presents normalized engine pollution emission factors (emission indices), reviews deficiencies in present emission data, and recommends future efforts to better analyze aircraft emissions. Primary goals of the report are to provide aircraft emission data which can be used in environmental impact assessments at many locations and to stimulate comment on the direction of future USAF efforts concerning the recommended projects.			

Reproduced by
NATIONAL TECHNICAL
INFORMATION SERVICE
U S Department of Commerce
Springfield VA 22151

14. KEY WORDS	LINK A		LINK B		LINK C	
	ROLE	WT	ROLE	WT	ROLE	WT
Environics Civil Engineering Air Pollution Aircraft Shelters Environmental Testing						

ia

AIR FORCE WEAPONS LABORATORY
Air Force Systems Command
Kirtland Air Force Base
New Mexico 87117

When US Government drawings, specifications, or other data are used for any purpose other than a definitely related Government procurement operation, the Government thereby incurs no responsibility nor any obligation whatsoever, and the fact that the Government may have formulated, furnished, or in any way supplied the said drawings, specifications, or other data, is not to be regarded by implication or otherwise, as in any manner licensing the holder or any other person or corporation, or conveying any rights or permission to manufacture, use, or sell any patented invention that may in any way be related thereto.

DO NOT RETURN THIS COPY. RETAIN OR DESTROY.

A

if

FOREWORD

The research was performed under Program Element 62601F, Project 19008W06.

Inclusive dates of research were 1 January 1973 through 13 Jul 1973. The report was submitted 4 September 1973 by the Air Force Weapons Laboratory Project Officer, Captain Dennis F. Naugle (DEE).

The authors wish to thank Captain William S. Blazowski and Mr. Robert Henderson of the Air Force Aero-Propulsion Laboratory, Wright-Patterson Air Force Base, Ohio, for his assistance in data collection.

This report has been reviewed and is approved.

Dennis F. Naugle
DENNIS F. NAUGLE
Captain, USAF, BSC
Project Officer

Donald G. Silva
DONALD G. SILVA
Major, USAF, BSC
Chief, Environics Branch

William B. Liddicoet
WILLIAM B. LIDDICOET
Colonel, USAF
Chief, Civil Engineering Research
Division

ABSTRACT

(Distribution Limitation Statement A)

The interest in pollution emissions from aircraft has been enhanced by Environmental Protection Agency's recent determination that major civilian airports are significant contributors to localized air-quality degradation. This report summarizes the USAF aircraft and engines in common use, presents normalized engine pollution emission factors (emission indices), reviews deficiencies in present emission data, and recommends future efforts to better analyze aircraft emissions. Primary goals of the report are to provide aircraft emission data which can be used in environmental impact assessments at many locations and to stimulate comment on the direction of future USAF efforts concerning the recommended projects.

CONTENTS

<u>Section</u>		<u>Page</u>
I	INTRODUCTION	1
	Engine Emission Factors (Indices)	1
	Total Emissions Inventory	3
	Air-Quality Assessment	4
	Summary of Public Laws and Executive Orders	7
II	CONCLUSIONS AND RECOMMENDATIONS	11
	Conclusions	11
	Recommendations	11
III	PRESENT AIRCRAFT EMISSION FACTORS	13
	Emission Factors Literature Review	13
	Composite Emission Factors	15
IV	SHORTCOMINGS IN EMISSION DATA	19
	Published Emission Data	19
	Collection of Reproducible Emission Data--Problems and Limitations	20
	Future Emission Factors	26
V	EFFORTS TO MEASURE AIRCRAFT EMISSION FACTORS	28
	Engine Priorities	28
	Measurement Locations	31
	Measurement Techniques	31
VI	EFFORTS TO OBTAIN AIRCRAFT LANDING AND TAKE-OFF CYCLES	35
	LTO Cycle Components	35
	LTO Data Collection Sheets	37
	References	41
	Distribution	46

ILLUSTRATIONS

<u>Figure</u>		<u>Page</u>
1	Ambient Air-Quality Analysis	2
2	Proposed Engine Testing Schedule	30
3	Engine Testing Equipment Schematic	32
4	Landing and Take-Off Cycles	36

TABLES

<u>Table</u>		<u>Page</u>
I	USAF Aircraft Included in AFWL Air-Quality Assessment Program	i
II	USAF Aircraft Engine Usage	6
III	Composite A/C Engine Emission Factors	16
IV	Survey of A/C Engine Emission Factors	21
V	A/C Engine Testing Priority List	29
VI	Mobile Emission Lab Instrumentation	33
VII	Landing and Take-Off Sample Data Sheet-Fixed Wing Aircraft	38
VIII	Landing and Take-Off Sample Data Sheet-Rotary Wing Aircraft	39

SECTION I

INTRODUCTION

Emission standards for control of pollution from civilian aircraft, as recently promulgated by Environmental Protection Agency (ref. 1) have intensified the need for an accurate evaluation of the Air Force's contribution to degradation of ambient air quality. While airbases are not intuitively considered to have as great an impact on the local environment as large civilian airports, the fact remains that the Air Force burns approximately 45 percent* of the jet fuel used in this country (more than any other single agency). Since it would be incongruous to force stiff emission controls on civilian airlines yet not control or even analyze the impact of DOD aircraft, several related projects have been initiated by Air Force System Command laboratories. The interrelationship of these projects will necessitate full cooperation between many Air Force and Department of Defense agencies. Figure 1 illustrates the applicable regulations, related projects, and uses of aircraft emissions analysis. An accurate environmental assessment of aircraft operations has three primary components: the measurement of pollution emissions per engine, accurate descriptions of aircraft operating procedures to calculate total emissions released, and a dispersion model to predict the resulting ambient air quality upon which potential health and welfare effects are based. Each component is described separately in the following sections.

1. ENGINE EMISSION FACTORS (INDICES)

An aircraft engine pollution emission factor (PEF) is the measured pollutant emitted per engine operating mode (i.e., idle, cruise, military, afterburner). Most data are normalized per 1000 pounds of fuel flow for ease of comparison. The term emission factor is most often used in air pollution engineering and can be used interchangeably with emission index (EI) usually used in aeronautical engineering. Measuring emission factors is a difficult and expensive procedure but it is essential for any overall environmental assessment of aircraft operations.

*Air Force JP-4 and JP-5 usage in 1971 was 6.782 billion gallons (ref. 2) while all other civilian jet fuel during that year was 8.165 billion gallons (ref. 3).

AMBIENT AIR QUALITY ANALYSIS

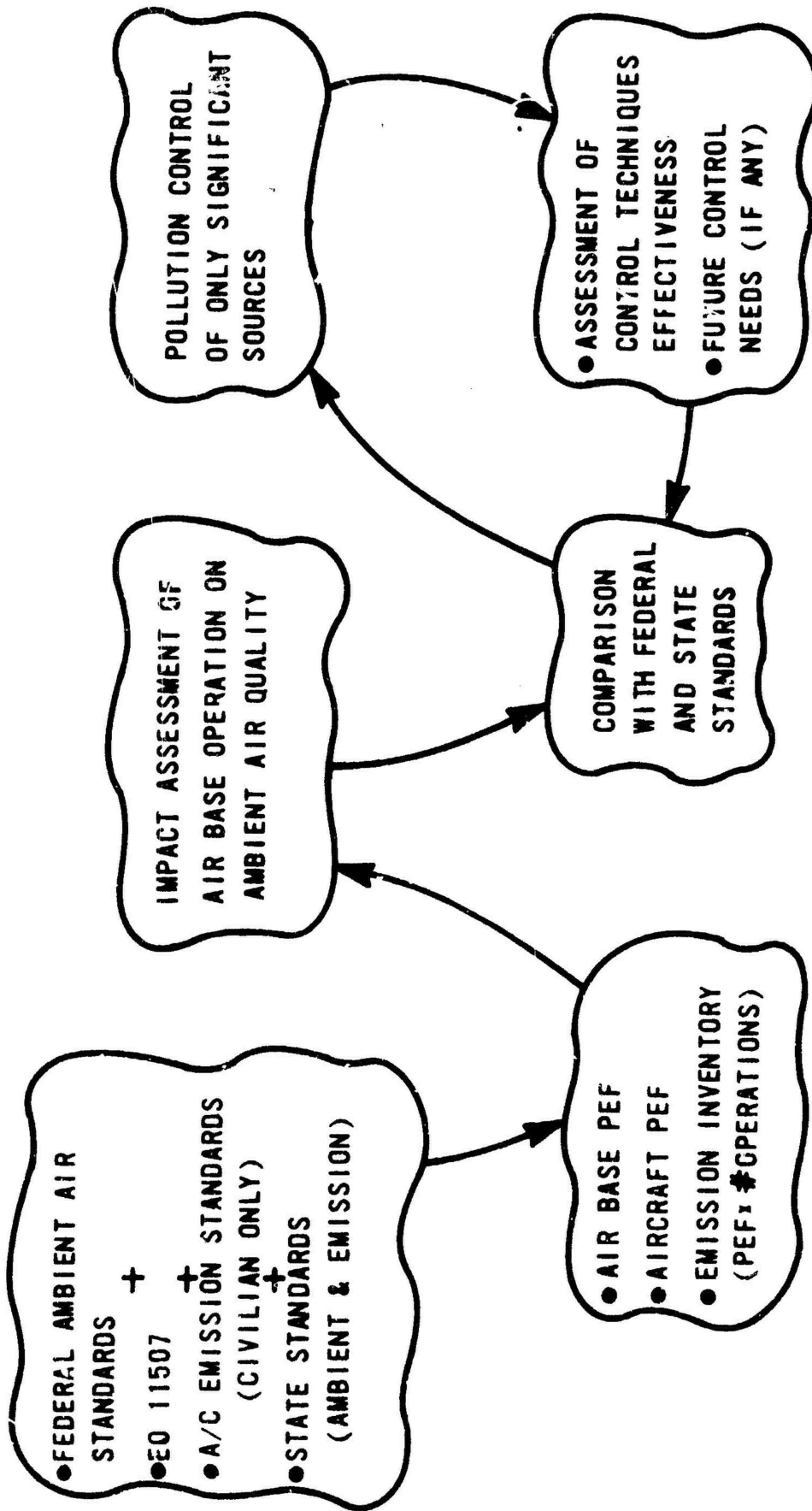

Figure 1. Ambient Air-Quality Analysis

By working closely with EPA, personnel from the Air Force Aeropropulsion Laboratory (AFAPL) developed pollution emission factor goals proposed for future Air Force aircraft engines (ref. 4). The term "goals" is used since goals are proposed to be used as design criteria by engine manufacturers but will not necessarily be issued as procurement regulations. Maximum allowable idle combustion inefficiencies of 1 percent are proposed in order to limit carbon monoxide (CO) and unburned hydrocarbon (UHC) emissions. Nitrogen oxide (NO_x) reduction of 50 percent (75 percent for large noncombat transport engines) are proposed. Smoke numbers which will ensure invisible aircraft smoke plumes have also been developed. The promulgated EPA regulations were changed to be less stringent compared to the EPA regulations proposed on 12 December 1972, and are now in close agreement with the AFAPL goals.

The establishment of military engine emission reduction goals is an example of taking the initiative to reduce pollution emission levels prior to the establishment of Federal regulations to force such reductions. In this manner, regulations which produce effective pollution reductions yet do not produce unacceptable cost or performance penalties will hopefully be developed. However, the environmental effectiveness of the proposed goals or even the necessity of such goals on all USAF aircraft cannot be evaluated without an emission inventory and a thorough air-quality assessment as described in the following two sections.

2. TOTAL EMISSIONS INVENTORY

Since engine emission factors are normalized per 1000 pounds of fuel burned per hour per engine operation mode, these factors are of limited usefulness without knowing the time periods that aircraft operate, the number of aircraft operations at each location of interest, and the engine fuel flow for each aircraft mode.

a. Landing and Take-Off Cycles

The time period to be used with each emission factor is obtained by developing an average landing and take-off (LTO) cycle for each aircraft. The EPA LTO cycles originally included the duration, in minutes, of five phases of aircraft operations:

- (1) taxi/idle (out)
- (2) take-off
- (3) climb-out (up to 3000 ft altitude)

- (4) approach (below 3000 ft altitude)
- (5) taxi/idle (in)

Some recent EPA studies have an expanded 10-phase LTO cycle (ref. 5) which is very similar to the proposed USAF cycle.

The LTO cycles used by EPA are not applicable to military aircraft due to both performance and operational differences. Unfortunately, military LTO cycles are not now available (see the proposed effort in section VI). Consequently, the major emissions study by EPA (ref. 6) did measure some military engine emissions factors but could not apply them due to the lack of LTO information.

Developing accurate LTO cycles for each aircraft is equally as important as engine emission measurement since both values are multiplied to obtain the quantity of pollutant per aircraft operation.

b. Operational Information

The final component to enable calculation of a total emissions inventory is the number of operations per aircraft per time of interest. Most air-quality assessments are done on both an annual and a short-term (1 to 24 hours) basis since the Federal ambient air-quality standards have the same basis. Consequently an inventory of operations on a short term through 1-year basis must be performed. Since the local airbase environment is of prime concern, the operations inventory must be compiled individually at each locale of interest. This information is often available from existing operational records but is quite time-consuming to compile. Also some operational information, such as the number of "touch and go" operations used to improve pilot proficiency, is not accurately recorded.

A listing of USAF aircraft, engine types, and percent usage is presented as tables I and II to indicate the many aircraft and corresponding engine types for which this operational information will be obtained.

3. AIR-QUALITY ASSESSMENT

Finally, a computerized model is needed to handle the vast amount of emission and operational input data. This model will also use climatological and meteorological data so that the total emission information will be converted to ambient air-quality values. An impact assessment is therefore made by the comparison of these predicted results with Federal air-quality standards for potential health and welfare effects.

Table I
USAF AIRCRAFT INCLUDED IN THE AFWL AIR QUALITY ASSESSMENT PROGRAM

<u>AIRCRAFT</u>	<u>NUMBER AIRCRAFT*</u>	<u>ENGINE TYPE**</u>	<u>ENGINES FOR AIRCRAFT</u>	<u>AFTERBURNER</u>
<u>Bombers</u>				
B-1	N/A	F-101 (GE)	4	Yes
B-52 C-E	268	J-57-19W (P)	8	No
F-G	247	J-57-43WB (P)	8	No
H	99	TF-33-3 (P)	8	No
B-57A-3C	60	J-65 (W)	2	No
E-G	67	TF-33-11 (P)	2	No
Subtotal = 7	= 741			
<u>Fighters</u>				
F-100A-F	734	J-57-21 (P)	1	Yes
F-101 A-H	472	J-57-55 (P)	2	Yes
F-102A	318	J-57-23 (P)	1	Yes
F-104A-G	149	J-79-3B (GE)	1	Yes
F-105B-G	259	J-75-19W (P)	1	Yes
F-106A-B	259	J-75-17 (P)	1	Yes
F-4A-D	1265	J-79-15 (GE)	2	Yes
E	634	J-79-17 (GE)	2	Yes
F-5A-B	24	J-85-13 (GE)	2	Yes
F-111A-F	304	TF-30-9 (P)	2	Yes
F-15	N/A	F-100 (P)	2	Yes
Subtotal = 11	= 4368			
<u>Attack Aircraft</u>				
A-7D	195	TF-41-A-1 (A)	1	No
A-10	N/A	TF-34-2(GE)	2	No
A-37A	24	J69-25 (Cont)	2	No
B	207	J-85-17A (GE)	2	No
Subtotal = 4	= 421			
<u>Cargo Aircraft</u>				
C-5A	53	TF-39 (GE)	4	No
C-9A	14	JT-8D-9 (P)	2	No
C-130A-S	715	T56-7 (A)	4	No
KC-135A	619	J-57-39W (P)	4	No
B-U	143	TF33-5 (P)	4	No
C-141A	281	TF-33-7 (P)	4	No
C-7	116	R2000	2	No
C-47A-Q	198	R-1830-SIC3-G (P)	2	No
C-97D-L	143	R-4360 (P)	4	No
C-119 G/K	125	R-3350-89BW/J-85	2/4 (plus 2 J-85's in "K" model only)	No
Subtotal = 9	= 2407			
<u>Training Aircraft</u>				
T-29	333	R-2800-99 (P)		NO
T-33A-B	882	J33-35 (A)	1	No
T-37B	812	J69-T25 (C)	2	No
T-38	1053	J85-5 (GE)	2	Yes
T-39A-F	141	J60-3A (P)	2	No
T-41A-C	240	O-300(C)	1	NO
Subtotal = 5	= 3461			
<u>Observation Aircraft</u>				
O-1A		O470 (C)	1	No
O-2A,B	394	O360D (C)	2	No
OV-10A	110	T-76	2	No
Subtotal = 3	= 516			
<u>Helicopters</u>				
HH-3	94	T58-5 (GE)	1	No
HH-43B-F	149	T53-1 (L)	1	No
HH-53BC	57	T64-7 (GE)	2	No
UH-1F	69	T58-3 (GE)	1	No
H,N,P	127	T53-13 (L)	1	No
Subtotal = 5	= 496			
<u>TOTALS</u>				
45 Aircraft types	12,410 Aircraft	8 Turbojets		7 Afterburning Engines
		8 Turboprops		
		5 Turboprops		
		8 Pistons		
		29 Basic Engine Models		

* The number of aircraft per model was compiled from the AFPLC prepared Aerospace Vehicle Inventory report dated 21 March 1973 which was declassified on 21 March 1973.

** Engine Manufacturers Code: GE - General Electric; P - Pratt & Whitney Aircraft; A - Allison; C - Continental; G - Garrett Air Research; L - Lycoming.

Table II
USAF AIRCRAFT ENGINE USAGE*

Engine	Percentage of Major Engines	Percentage of Flying Hours
J-57	30.1	26.3
TF-33	9.3	17.8
T-56	11.2	15.8
J-85	10.5	10.5
J-79	15.6	9.5
J-69	6.6	7.2
J-60	1.4	2.5
T-76	.9	1.6
TF-30	2.8	1.5
J-33	2.2	1.5
TF-39	.9	1.1
J-75	2.0	1.0
T-58	1.4	1.0
TF-41	1.7	.8
J-65	1.1	.5
T-64	.5	.4
T-53	.6	.3
T-400	.5	.3
J-71	.4	.3
J-47	.3	.1

* Based on data from AFLC/WPAFB for 19,036 installed active engines for the first quarter of 1972.

Development of this computerized air-quality assessment model is currently underway using the general Gaussian dispersion equations and incorporating the puff theory and stagnation condition treatments as developed by Argonne National Laboratory. This model will place major emphasis on developing characterizing pollution from the take-off and landing of Air Force aircraft. Additionally, dispersion from municipal, industrial, and vehicular pollution sources as previously developed by EPA and others will be included as an integral part of this model so that comparisons to aircraft can directly be made.

Application of the air-quality assessment model will be initially made at five Air Force bases. Bases with large numbers of aircraft operations as flown by SAC, MAC, TAC, ATC, and AFLC will be chosen.

4. SUMMARY OF PUBLIC LAWS AND EXECUTIVE ORDERS

The Federal Government has initiated laws for the specific purpose of preventing further degradation of the atmosphere. The clean air act of 1963 is the first major legislation to be enacted for the purpose of investigating and controlling air pollution, mainly at the regional and local level. The Act gives the Federal Government authority to intervene in interstate problem areas. Another vehicle that the Federal Government has used to express concern in pollution is that of the Executive Order. One of the earliest of these dealing with air pollution is Executive Order 10779 (ref. 7) (August, 1958) which directs Federal agencies to cooperate with state and local officials.

The first mention of aircraft emissions as a possible source of air pollution in a Federal law came about in the Air Quality Act of 1967. Under section 2116 of the Emission Standards Act of 1967 is the following statement (ref. 8):

"The Secretary shall conduct a full and complete investigation and study of the feasibility and practicability of controlling emission from jet and piston aircraft engines and of establishing national emission standards with respect thereto..."

This statement concerning the establishment of national emission standards for aircraft engines is the primary reason that considerable public interest has been generated in the area of aircraft emissions determination.

The Clean Air Act of 1970 (ref. 9) which created the Environmental Protection Agency contains additional specific references to possible pollution being emitted from aircraft operations. The Clean Air Act contains in section 231.1 the following statement:

"The Administrator shall commence a study and investigation of emissions of air pollutants from aircraft in order to determine:

- A. The extent to which such emissions affect air quality in air quality regions throughout the United States and,
- B. The technological feasibility of controlling such emission."

Based on the information obtained from this study the administrator (EPA) was to issue proposed emission standards applicable to the emission of any air pollutant from any class or classes of aircraft or aircraft engines (ref.10). The Clean Air Act of 1970 also contains a section (118) that directs all Federal facilities to:

"...comply with Federal, State, Interstate and local requirements respecting control and abatement of air pollution to the same extent that any person is subject to such requirements."

The next sentence in this section does allow the President to exempt any Federal emission source if he determines that it is in the best interest of the country to do so.

Prior to the passage of the Clean Air Act of 1970 (December 1970) the President issued Executive Order 11507 (ref. 11) (February 4, 1970), "Control of Air and Water Pollution." The following statement, made by the President upon signing Executive Order 11507 shows the intent of the executive order:

"The order I am issuing today will require that all projects or installations owned by or leased to the federal government be designed, operated, and maintained so as to conform with air and water quality standards present and future--which are established under federal legislation."

The first section of the Executive Order, the policy statement, intends to broaden the responsibility of the Federal Government from maintaining its own facility to providing leadership to the nation in the areas of air and water pollution control and abatement.

One could assume from the intent of this Executive Order that the Air Force (in the following case) should take the lead in determining the extent of air pollution produced by military aircraft operations, and when once determined, should derive a plan to eliminate as much of the pollution as is practicably possible. This task should be met and accomplished irrespective of the speed of

compliance in the civilian sectors. Also, this order requires the Federal facilities to comply with all present and, more importantly, future air and water quality standards.

The proposed standards for aircraft and aircraft engines were published in the Federal Register (ref. 12) on Tuesday, December 12, 1972 at the same time proposed standards for ground operation of aircraft to control emissions were published (ref. 13). Three major reasons for proposing these standards are stated as follows:

"...(1) that the public health and welfare is endangered in several air quality control regions by violation of one or more of the national ambient air quality standards,

...(2) that airports and aircraft are now, or are projected to be, significant sources of emissions of carbon monoxide, hydrocarbons and nitrogen oxides in some of the air quality control regions in which the national ambient air quality standards are being violated, as well as being significant source of smoke;

...(3) that maintenance of the national ambient air quality standards and reduced impact of smoke emission requires that aircraft and aircraft engines be subjected to a program of control compatible with their significance as pollution sources."

The first of the proposed standards, "Control of Air Pollution From Aircraft and Aircraft Engines," was promulgated on 17 July 1973. Emission standards are set for total hydrocarbons, carbon monoxide, oxides of nitrogen, and smoke. Standards apply to newly manufactured engines and in some cases, in-use engines. Test procedures are also indicated. These standards, however, do not currently apply to military aircraft.

The second of the proposed standards, entitled "Ground Operation of Aircraft to Control Emission," deals mainly with suggesting ways of modifying ground operations so as to reduce emissions of the aircraft when they are on the ground during idle and taxi modes. Promulgation of these standards is being delayed to allow these modifications to be investigated more fully by the Secretary of Transportation since they could possibly lead to unsafe operating conditions.

The summary of the public laws and executive orders just presented clearly states that emissions from aircraft operations are a significant cause of pollution in some areas and can become more significant in the future. With this in mind, EPA has proposed standards that should be implemented to remedy the

situation. Section 118 of the Clean Air Act of 1970 places responsibility on the Federal Government to comply with the Clean Air Act, but Executive Order 11507 (although signed before the Clean Air Act) places even greater responsibility on the Federal Government, in that the government should take the lead in controlling air pollution. Therefore, the Air Force must take the lead and do all that is possible to determine the significance of the aircraft pollution problem and then do as much as required to reduce the pollution from military aircraft operation.

SECTION II

CONCLUSIONS AND RECOMMENDATIONS

The following conclusions and recommendations are presented as a very brief summary of the material which is treated in greater depth in later sections.

1. CONCLUSIONS

Present aircraft emission factors for military aircraft are based on an inadequate data base due to the sparse number of engines tested. Engine to engine variability is therefore largely unknown.

Data on particulate emissions in all engine modes and on all pollutants in afterburner engine modes are particularly lacking.

While EPA has determined that large civilian airports can significantly contribute to the exceeding of Federal ambient air-quality standards, a detailed study of the impact of large USAF airbases on surrounding air quality has never been accomplished. Neither the requirement nor the degree of need for USAF emission controls has therefore been established.

Average landing and take-off (LTO) cycle emissions characteristics for USAF aircraft have not been determined. The accuracy of this determination is a major factor in the overall accuracy of any aircraft impact assessment.

2. RECOMMENDATIONS

The AFSC project for the construction of an aircraft engine mobile emission testing laboratory by Arnold Engineering Development Center (AEDC) should be continued to develop a capability to measure relatively large numbers of engines presently in the USAF inventory.

Emission measurements of ten engines per model (J-69, TF-30, etc.) are initially recommended to investigate engine to engine variability.

Use of a mobile emission laboratory to performing tests at engine rebuilding facilities (such as AFLC Air Material Areas) is recommended as opposed to transporting large numbers of aircraft engines to a central testing location such as AEDC. In this way, the logistical problems of obtaining and operating active engines are minimized.

AFLC permission to allow emission tests at their AMA engine test facilities should be sought. While every effort will be made to perform these tests on a minimum interference basis, engine operating times longer than normally used are needed to obtain the complex emission measurements.

A thorough impact analysis using the best available aircraft emission factors is recommended. Primary goals include:

- a. Determination of airbase effects on surrounding air quality as compared to civilian airport contributions and Federal standards.
- b. Determination of the significance of each type of USAF aircraft on air quality.
- c. Suggestion of pollution control strategies which are sufficient to prevent significant environmental degradation yet not overly stringent so that high costs are incurred to produce minimal environmental benefits.

Obtaining average LTO cycles for each type of active USAF aircraft is recommended. The suggested method of data collection is through Command channels using the sample data sheet format as presented in section VI.

SECTION III

PRESENT AIRCRAFT EMISSION FACTORS

The determination of aircraft emission factors has been proceeding for approximately the last 13 years, with the only significant contributions coming in the last 5 years. The progress over this 5-year period in obtaining the emission factor information is reviewed in the following section.

1. EMISSION FACTORS LITERATURE REVIEW

a. Nature and Control of Aircraft Engine Exhaust Emissions (ref. 14)

In November 1968, Northern Research and Engineering Corporation (NREC) published a report prepared for the National Air Pollution Control Administration entitled as above. The pollutant emissions published in this report (ref. 15) were gathered from three previously published reports: Air Pollution From Commercial Jet Aircraft in Los Angeles County (ref. 16), Oxides of Nitrogen From Gas Turbines (ref. 17) and Air Pollution Emissions From Jet Engines (ref. 18) and from direct communications with engine manufacturers (refs. 19 through 23). Although this report presents the largest source of emission data to November 1968, it is of limited use for Air Force objectives. The major drawback is that the data are presented by engine category (turbofan, turbojet and turboprop) and not by specific engine type or aircraft type. The 1960 report, "Air Pollution From Commercial Jet Aircraft in Los Angeles County", was based on an intensive study of only one type of turbojet, the Pratt & Whitney JT3C-6 (ref. 16). The article "Oxides of Nitrogen From Gas Turbines" published in January 1968 in the Journal of the Air Pollution Control Association contains data from two commercial aircraft turbine engines, mainly the Pratt and Whitney JT3C-6 and the Pratt and Whitney JT8D (ref. 17). The article entitled "Air Pollution Emissions From Jet Engines" published in June 1968 in the Journal of the Air Pollution Control Association contained data on three representative Air Force jet engines (T-56, J-57) and TF-33) that have counterparts in the civilian airlines (ref. 18).

b. Jet Engine Test Cell Emissions

In December of 1970 the USAF Environmental Health Laboratory published a preliminary report (ref. 24) with the above title. This report included the

results of a literature survey on emission potentials of jet engines and a project status report. The emission potentials were obtained from the following three reports: Air Pollution From Commercial Jet Aircraft in Los Angeles County (ref. 13), Air Pollution Emissions From Jet Engines (ref. 15), and from Nature and Control of Aircraft Engine Exhaust Emissions (ref. 12). As in the Northern Report, the data were presented by the three major categories, turbofan, turbojet, and turboprop.

c. The Potential Impact of Aircraft Emission Upon Air Quality

The second report of Northern Research and Engineering Corporation, with the above title, was published in December 1971 (ref. 25). The emission factors in this report were presented in a similar manner as the first NREC report with the major modification that the engines were designated by the class of aircraft on which they were used, and an example engine in each class was listed by series name. This report was the first major report that contained data in any quantity on emissions specifically from military engines.

d. Analysis of Aircraft Exhaust Emission Measurements

During the same time period that NREC was conducting its study under contract to EPA, work was progressing under another EPA contract by Cornell Aeronautical Laboratories to gather emission factors. The raw data on emission factors were submitted by eight contractors to Cornell Aeronautical Laboratory for data reduction. Cornell then prepared the formal report entitled as above which was published in October 1971 (ref. 6). The Cornell report contains emission data on 392 engine tests, comprised of 199 turbine/turboprop tests, 140 piston engine tests and 53 tests on auxiliary power units (ref. 26). The emission data are reported by series, model and serial number of the engine tested instead of the method previously used of reporting by aircraft class or engine category. The emission data contained in this report are mainly for engines used by civilian aviation; however, the report does contain a limited quantity of data from military engines.

e. Noise and Air Pollution Emissions from Noise Suppressors for Engine Test Stands and Aircraft Power Check Pads

In January of 1972, the USAF Environmental Health Laboratory at McClellan AFB published a report (ref. 27), entitled as above, on emission factors that was the result of work completed after his preliminary report of 1970. The 1972 report contains data on military aircraft engines operating in the afterburner

mode. This report also represents one of the few sources of quantitative information concerning particulate loading in exhaust gases from military or civilian jet engines.

f. Assessment of Pollutant Measurements and Control Technique and Development of Pollutant Reduction Goals for Military Aircraft Engines (ref. 4)

The above AFAPL report was published in November of 1972 and therefore represents the most recent compilation of emission factors for military aircraft engines. The emission factors tabulated in this report were gathered from the following titles: "Analysis of Aircraft Exhaust Emission Measurements" (ref. 6), "Measurement of Pollution Emissions From Afterburning Turbojet Engine at Ground Level Part II-Gaseous Emissions" (ref. 28), "Letter Report on Gaseous Emissions from the J-57-F21A Engine" (ref. 29), "Exhaust Emission Characteristics-GE Engines" (ref. 30), and personal correspondence of the authors (ref. 31). The format for presenting the emission factors in this report varies from the reports previously reviewed. The emission factors are presented only for the mode that is considered significant for the particular pollutant under consideration. The pollutants and the modes are as follows: CO and hydrocarbons for the idle mode and NO_x for the take-off mode.

2. COMPOSITE EMISSION FACTORS

The emission factors presented in table III are composite values of air pollutant emissions from military turbine and piston engines. While many of these values are not supported by a strong statistical data base, they represent the numbers which in the authors' best judgment should be used as the most accurate emission factor based on present data. These values should satisfy the immediate need for preliminary emission factors to be used in Environmental Impact Assessments and Statements. The emission factors presented in this table are a composite of published data or in some cases represent the only measurement presently available for the specific engine series. The footnotes that accompany each emission factor provide the reference or references that were used in determining the composite value and the method used in determining the numerical value.

Emission factors in table III represent the emissions from about 43 percent of all engine models currently in use by the Air Force but account for about 82 percent of the total engine usage. To one who is not familiar with engine model and associated aircraft, the data could have only limited usefulness. Therefore,

Table III
COMPOSITE A/C ENGINE EMISSION FACTORS

Military	Engine	Civilian	Mode	Fuel Rate Average (1000 lb/hr)	Pollutant Emission Rate (lbs/1000 lb of fuel)			
					Particulates	Nitrogen Oxides	Carbon Monoxide	Unburned Hydrocarbons
J-79			IDLE	1.068 ¹	32.4 ¹	3.69 ¹	59.0 ¹	6.18 ¹
			NORMAL-Cruise	8.33 ¹	20.0	7.96 ¹	2.25 ¹	0.03 ¹
			MILITARY	9.47 ¹	12.8 ¹	11.39 ¹	1.9 ¹	0.5 ¹
			AFTERBURNER	30.55 ¹	7.18 ¹	5.08 ¹	31.9 ¹	0.4 ¹
J-57			IDLE	1.17 ⁷	8.3 ⁹	2.02 ⁹	80.0 ⁹	85.0 ⁹
			NORMAL-Cruise	7.28 ⁷	10.0	9.26 ⁹	1.95 ⁹	.84 ⁹
			MILITARY	8.68 ⁷	12.0 ⁹	10.50 ⁹	1.28 ⁹	.22 ⁹
J-52			IDLE	0.71 ¹⁰	7.3 ¹¹	6.74 ¹⁰	66.9 ¹⁰	21.85 ¹⁰
			NORMAL-Cruise	5.34 ¹⁰	49.0 ¹¹	10.0 ¹⁰	1.90 ¹⁰	.08 ¹⁰
			MILITARY	6.56 ¹⁰	22.0 ¹¹	9.36 ¹⁰	1.73 ¹⁰	.07 ¹⁰
TF-33			IDLE	1.18 ¹²	8.0 ¹³	1.65 ¹⁰	116.7 ¹⁰	107.6 ¹⁰
			NORMAL-Cruise	7.32 ¹²	14.0 ¹³	11.26 ¹⁰	1.54 ¹⁰	.37 ¹⁰
			MILITARY	8.60 ¹²	14.0 ¹³	13.63 ¹⁰	.71 ¹⁰	.27 ¹⁰
TF-30			IDLE	1.25 ¹	26.5 ¹	1.51 ¹⁰	72.9 ¹⁰	17.72 ¹⁰
			NORMAL-Cruise	6.65 ¹⁰	24.0	12.16 ¹⁰	1.20 ¹⁰	0.08 ¹⁰
			MILITARY	7.12 ¹	23.7 ¹	13.79 ¹⁰	1.37 ¹⁰	0.10 ¹⁰
			AFTERBURNER	42.85 ¹	5.36 ¹	4.47 ⁰	24.8 ⁰	0.1 ⁰

Footnotes:

- ¹ Data from Burnett, R. D.: Noise and Pollution Emissions from Noise Suppressors for Engine Test Stands and Aircraft Power Check Pads. Flow Rates are averaged. Report 71M-19 January, 1972 USAF Environmental Health Laboratory.
- ² Rogdan, Leonard and McAdams, H. T.: Analysis of Exhaust Emission Measurements. CAL Report No. MA-5007-K-1: October, 1971. Averages by similar fuel flow rates at 80-90° T.O. Power.
- ³ Data from (1). This includes organic soluble and insoluble particulates.
- ⁴ Average of raw data from (1 & 2). For J-79.
- ⁵ Average of raw data from (2). For J-79.
- ⁶ Data for one engine test obtained from (1).
- ⁷ PMA specification A-1730 February, 1958 Guaranteed Rating.
- ⁸ Data from Nature and Control of Aircraft Engine Exhaust Emissions: Northern Research and Engineering Corporation. Report No. 1134-1. Eng. A - JTC. Data does not specify whether soluble particulates are included or not.
- ⁹ Average of one set of data on the J-57 from (2) and two sets of average data from H. T. McAdams: Analysis of Exhaust Emission Measurements: Statistics CAL Report No. MA-5007-K-2; November, 1971 - for the JTC.
- ¹⁰ Average of raw data from (2) for J-52.
- ¹¹ Data from Contract Status Report No. 3. Fred Robson, United Aircraft Research Laboratories; Original Data Source: measurements by Environment-One as reported in Report on Abatement of Particulate Emissions and Noise from Jet Engine Test Cells Including Reduction of Gas Flow with TEST Augmentor-Scrubber System. Teller Environmental Systems, Inc.
- ¹² PMA Specification A-17586 March, 1962 Guaranteed Rating.
- ¹³ Data from (1) does not specify if soluble particulates are included.
- ¹⁴ Average of 4 data sets from (2), JT30, and 1 set of data from (1).
- ¹⁵ PMA Specification A-6123-A September, 1970 Guaranteed Rating.
- ¹⁶ Average of 12 sets of raw data from (2) for TF-30.

Table III (Cont'd)
COMPOSITE A/C ENGINE EMISSION FACTORS

Engine	Civilian	Mode	Fuel Rate Average (1000 lb/hr)	Particulates	Nitrogen Oxides	Carbon Monoxide	Unburned Hydrocarbons
J-45		IDLE	.65 ¹		5.3 ¹	150.0 ¹	42.0 ¹
		NORMAL-Cruise	1.8 ¹		3.6 ¹	58.0 ¹	9.4 ¹
		MILITARY	2.65 ¹		5.4 ¹	46.0 ¹	5.8 ¹
		AFTERBURNER	7.70 ¹		3.1 ¹	35.0 ¹	4.0 ¹
J-5		IDLE	1.7 ²	.5	1.29 ³	76.2 ³	56.86 ³
		NORMAL-Cruise	11.3 ²		11.9 ²	1.4 ²	.1 ²
		MILITARY	13.2 ²	1.05	3.2 ³	.6 ³	.23 ³
		AFTERBURNER	57.7 ²				
TF-55		IDLE	1.19 ²		5.36 ²	50.0 ²	17.0 ²
		NORMAL-Cruise	6.5 ²		42.8 ²	3.0 ²	.3 ²
		MILITARY	12.85 ²		3.93 ³	28.10 ³	11.92 ³
		IDLE	.546 ³		11.11 ³	1.57 ³	.25 ³
T-76		NORMAL-Cruise	1.908 ³		10.98 ³	1.04 ³	.20 ³
		MILITARY	2.079 ³				
		IDLE	.192 ⁵		7.35 ⁵	23.78 ⁵	7.42 ⁵
		NORMAL-Cruise	.347 ⁵		9.88 ⁵	5.92 ⁵	.11 ⁵
O-470 R		MILITARY	.387 ⁵		10.27 ⁵	2.28 ⁵	.064 ⁵
		IDLE	.01512 ⁶		1.02 ⁶	742.5 ⁶	191.4 ⁶
		NORMAL-Cruise	.0855 ⁶		9.37 ⁶	691.66 ⁶	9.46 ⁶
		MILITARY	.13125 ⁶		1.11 ⁶	1155.8 ⁶	20.40 ⁶
10-360		IDLE	.01517 ⁷		1.09 ⁷	848.18 ⁷	144.50 ⁷
		NORMAL-Cruise	.06788 ⁷		6.60 ⁷	371.97 ⁷	17.40 ⁷
		MILITARY	.0887 ⁷		5.32 ⁷	1031.25 ⁷	22.47 ⁷

Footnotes:

- ¹ Lazellier, G. R. and Gearhart, J. M.: Measurement of Pollutant Emissions From an Afterburning Turbojet Engine at Ground Level.
- ² Bobson, F. L., Kristen, A. S. and Lessard, P. D.: Analysis of Jet Engine Test Cell Pollution Abatement Methods. AFWL-TR-73-13.
- ³ Average of data from reference 2.
- ⁴ Bogdan, Leonard and McAdams, H. T.: Analysis of Exhaust Emission Measurements. CAL Report No. MA-5007-A-1. Oct. 15, 1971.
- ⁵ Engineering Staff: "Exhaust Emissions Test Aircraft Propulsion and Auxiliary Power Gas Turbine Engines", Air Research Manufacturing Company of Arizona.
- ⁶ Bogdan, Leonard and McAdams, H. T.: Analysis of Exhaust Emission Measurements. CAL Report No. MA-5007-K-1. October 15, 1971. Page 11-35.
- ⁷ Bogdan, Leonard and McAdams, H. T.: Analysis of Exhaust Emission Measurements. CAL Report No. MA-5007-K-1. October 15, 1971. Page 1-108.

table I in section I gives the aircraft's common name with number of aircraft in service, the type of power plant including model and series, the number of engines per aircraft, and whether or not the engine has an afterburner. A comparison of tables I and III will indicate the degree of unavailability of emission factors. For example, of the 21 turbine engine models presented in table I, only 10 are presented in the composite table II as having emission factors available.

The emission factors presented in table III were given by model number only and not further subdivided by series. This procedure was taken even though there are many series within some models (as indicated by the 5 series of model J-57 presented in table I) due to the limited availability of emission data from specific series. The emission factors table will be expanded to include specific series when additional data becomes available. Until then, care should be exercised in the use of the data contained in table III, especially when applying the emission factors to engines that have possibly been retrofitted with so-called "clean combustors."

SECTION IV
SHORTCOMINGS IN EMISSION DATA

1. PUBLISHED EMISSION DATA

The composite emission factors presented in the previous sections were derived from the data contained in table IV. This table contains the majority jet engines or their civilian counterparts. Emission factor data contained in this table is often inconsistent for any particular engine. The primary reasons for this lack of consistency among the emission factor data are as follows:

a. The number of tests performed in obtaining the emission data are too few (in many cases only one test) to obtain generalized information about emissions of engines of a specific series or model. Actual variability between apparently similar engines is therefore unknown.

b. The emission factors presented in table IV were not always obtained under the same engine operating conditions for any specified operational mode. For example, the fuel flow rate could vary by 500 to 1000 pounds per hour and the test still would be considered to be in one specific operational mode such as normal cruise. This variation in fuel flow rate would naturally cause differences in the quantities of specific pollutant emissions produced. Although actual emissions may exhibit this kind of variation in operating conditions, collected data have to be reduced to general engine categories in order to give an indication of the quantity of emission likely to be produced under identifiable operational modes.

c. Specific series within a particular model of aircraft engines will exhibit differences in the quantities of pollutants emitted. Yet most of the data prior to the Cornell report presented data only by engine model and not series. This variability is illustrated in the data in the Cornell report on various series of the TF-30 engines.

d. Not all of the data presented were obtained by the same testing procedures. The location of sampling equipment, sampling lines, probe designs, analysis procedures and testing skill can cause wide variations in the quantities of specific pollutants measured. The wide variety of sampling and reporting procedures used

for particulate matter is especially critical. A discussion on sampling procedure is presented later in this portion of the report.

e. Different ambient conditions, especially temperature and humidity, can cause actual differences in emission characteristics.

2. COLLECTION OF REPRODUCIBLE EMISSION DATA--PROBLEMS AND LIMITATIONS

The problems and limitations of obtaining reproducible and/or statistically significant emissions factors are the direct result of sampling problems connected with the actual testing of the engines or the sizable expense involved in aircraft engine testing, thus negating a large sample size.

The majority of the problems associated with the actual sampling of turbine engines should become of less significance as test procedures become more standardized. The use of a specific sampling procedure by all investigators should eliminate many of the specific problems that become evident in the compilation of table IV. Some of the specific problems are discussed in the following paragraphs.

a. Test Location

At present, there are three major configurations for testing the emissions from jet engines. These are:

(1) Engine Exhaust Plane Testing

Measurements are made at the engine exhaust plane inside a test cell.

(2) Engine Exhaust Plume Testing

This method uses an outdoor test stand instead of a confined exhaust stream as in a test cell. The sampling probe is inserted in the plume at various predetermined locations.

(3) Stack Testing

The sampling probe is located in the exhaust area of a jet engine test cell or runup stand, with the sampling of the plume across the known cross section area.

All of the above testing configurations have major limitations in their use and ability to give a true representation of the exhaust products that exist in the ambient atmosphere.

Table IV
SURVEY OF A/C ENGINE EMISSION FACTORS

Engine	Mode	Fuel Rate Average (1000 lb/hr)	Carbon Monoxide	Pollutant Emission Rate (lbs/1000 lb of fuel)	Unburned Hydrocarbons
J-79	Idle	1.068 ¹	62.5 ¹	6.18 ^{1,10}	9.0 ¹⁰
	NORMAL-Cruise	8.54 ¹	2.25 ^{1,10}	0.03 ¹⁰	
	MILITARY	8.47 ¹	2.73 ¹	.5 ^{1,10}	
	AFTERBURNER	30.55 ¹	31.9 ¹	.4 ^{1,10}	
J-57	Idle	1.17 ⁵	63.4 ⁷	4.2 ⁷	72.9 ⁶
	NORMAL-Cruise	7.28 ⁴	2.45 ⁶	MIL ⁶	MIL ⁹
	MILITARY	8.68 ⁴	6.5 ⁷	1.5 ⁷	MIL ⁹
				2.14 ¹⁰	
J-52	Idle	1.0 ¹⁰	66.9 ¹⁰	21.85 ¹⁰	
	NORMAL-Cruise	8.3 ¹⁰	1.99 ¹⁰	.08 ¹⁰	
	MILITARY	10.0 ¹⁰	1.73 ¹⁰	.07 ¹⁰	
				2.14 ¹⁰	
TF-33	Idle	1.18 ²	104.2 ¹¹	91.0 ⁹	60.0 ¹¹
	NORMAL-Cruise	7.32 ²	1.4 ⁹	MIL ⁹	MIL ⁹
	MILITARY	8.60 ²	NIL ⁹	0.3 ¹¹	0.3 ¹¹
				17.72 ¹⁰	
TF-30	Idle	1.25 ¹	46.4 ¹	3.47 ^{1,10}	
	NORMAL-Cruise	6.63 ^{1,9}	1.2 ¹⁰	0.08 ¹⁰	
	MILITARY	7.12 ¹	3.04 ¹	.38 ^{1,10}	0.10 ^{1,10}
	AFTERBURNER	42.85 ¹	24.8 ¹	.1 ^{1,10}	

Footnotes:
¹ Data from Burnett, R. D.: Noise and Pollution Emissions from Noise Suppressors for Engine Test Stands and Aircraft Power Check Pads. Report 71M-19 January, 1972 USAF Environmental Health Laboratory.
² PMAA Specification A-17586 March 1962 Guaranteed Rating.
³ Data from Nelson, A. H.: Collection and Assessment of Aircraft Emissions Baseline Data - Turbine Engines PMAA report PMA-4339 February 1972 JT30 Data.
⁴ Sum of ethylene and gaseous hydrocarbons (hexane), reported here as CH₄.
⁵ G.I. Specification E-2027 24 September 62 Guaranteed Rating.
⁶ PMAA Specification A-1730 February 1958 Guaranteed Rating.
⁷ Data from Nature and Control of Aircraft Engine Exhaust Emissions: Northern Research and Engineering Corp. Report No. 1134-1, Eng. A-JT3C.
⁸ Data from McAdams, H. T.: Analysis of Exhaust Emission Measurements: Statistics. CAL Report No. MA-5007-K-2 November 1971. JT3C Data.
⁹ Approximately 50% of this table was compiled by Dr. Fred Robeson of United Aircraft Research Laboratories. His table was presented in Contract Status Report No. 3 May 1, 1972.
¹⁰ Data from Burnett, R. D.: Noise and Pollution Emissions from Noise Suppressors for Engine Test Stands and Aircraft Power Check Pads. Report 71M-19 January, 1972 USAF Environmental Health Laboratory.
¹¹ PMAA Specification A-6123-A September 1970 Guaranteed Rating.
¹² Leonard Bogdan and H. T. McAdams: Analysis of Exhaust Emission Measurements. CAL Report No. MA-5007-K-1 October 15, 1971.
¹³ Data from Ref. B above; JT30 Data not JT3C.

Table IV (Cont'd)
SURVEY OF A/C ENGINE EMISSION FACTORS

Engine	Civilian	Mode	Fuel Rate Average (1000 lb/hr.)	Particulates	Pollutant Emission Rate (lb./1000 lb of fuel)	Nitrogen Oxides
J-79		IDLE	1.068 ¹	32.4 ¹	14.7 ² 24.7 ² 4.6 ³	5.14 ¹⁷ 2.24 ¹⁷
		NORMAL-Cruise	8.54 ¹	9.6 ²	5.4 ³	7.96 ¹⁷
		MILITARY	8.47 ¹	12.8 ¹	9.25 ² 17.1 ³ 28.7 ³	13.8 ¹ 8.99 ¹⁷
		AFTERSURNER	30.55 ¹	7.18 ¹	5.85 ² 8.63 ³	5.08 ¹
J-57	JT3C	IDLE	1.17 ⁶	8.3 ⁷	1.5 ⁷ 2.5 ⁸	1.40 ⁹ 2.2 ¹⁰ 2.07 ¹¹
		NORMAL-Cruise	7.28 ⁶	12.0 ⁷	10.4 ⁸ 5.2 ⁹	8.19 ¹⁷
		MILITARY	8.68 ⁶	17.7 ²	10.5 ⁹ 8.52 ¹⁷	
J-52	JT80	IDLE	1.0 ¹⁷	5.0 ² 8.8 ³	6.74 ¹⁷	
		NORMAL-Cruise	8.3 ¹⁷	49.0 ²	10.0 ¹⁷	
		MILITARY	10.0 ¹⁷	17.7 ² 26.3 ³ 123.0 ³	9.36 ¹⁷	
TF-33	JT30	IDLE	1.18 ¹²	8.0 ^{12,13} 2.4 ¹¹	1.5 ¹⁰ 1.6 ¹⁰	1.06 ¹⁰ 1.5 ¹¹ 2.08 ¹⁰
		NORMAL-Cruise	7.32 ¹²	14.0 ^{12,13}	13.0 ¹⁰ 10.87 ¹⁰	10.23 ¹⁰ 9.92 ¹⁰
		MILITARY	8.60 ¹²	14.0 ^{12,13} 1.9 ¹⁰	14.0 ¹³ 2.1 ¹¹ 13.96 ¹⁰	12.27 ¹⁰ 12.26 ¹⁰ 14.72 ¹⁰
TF-30	JT11	IDLE	1.25 ¹	26.5 ¹ 10.8 ¹ 8.2 ¹	6.52 ¹ 1.5 ¹⁷	
		NORMAL-Cruise	6.63 ¹⁰	3.1 ⁵ 3.2 ⁹	12.16 ¹⁷	
		MILITARY	7.12 ¹	23.7 ¹ 4.0 ³ 22.7 ³	19.7 ¹ 13.79 ¹⁷	
		AFTERSURNER	42.95 ¹	5.36 ¹	4.47 ¹	

Footnotes:

- Data from Burnett, R. D.: Noise and Pollution Emissions from Noise Suppressors for Engine Test Stands and Aircraft Power Check Pads. Report 71H-19 January, 1972 USAF Environmental Health Laboratory.
- Measurements by Environment-One as reported in Report on Abatement of Particulate Emissions and Noise from Jet Engine Test Cells Including Reduction of Gas Flow with TESI Augmentor-Scrubber System. Teller Environmental Systems, Inc.
- Based on analysis of scrubber water as reported in reference 2 above.
- Sum of ethylene and gaseous hydrocarbons (as hexane).
- G.E. Specification E-2027, 24 September 1962 Guaranteed Rating.
- PMA Specification A-1730, February 1958 Guaranteed Rating.
- Data from Nature and Control of Aircraft Engine Exhaust Emissions: Northern Research and Engineering Corporation, Report No. 1134-1, Eng. A-JT3C.
- Data from McAdams, H. T.: Analysis of Exhaust Emission Measurements: Statistics. CAL Report No. MA-5007-k-2 November, 1971. JT3C Data.
- Approximately 50 percent of this table was compiled by Dr. Robeson of United Aircraft Research Laboratories. His table was presented in Contract Status Report No. 3, May 1, 1972.
- SWRI data from above for JT3C.
- Data from reference 7 above; Eng. B - JT3C.
- Data from reference 7 above; Eng. C - J57.
- PMA Specification A-17586 March 1962 Guaranteed Rating.
- Data from Nelson, A. W.: Collection and Assessment of Aircraft Emissions Baseline Data - Turbine Engines. PMA Report PHA-6339 February 1972 JT3D Data.
- Average for LACAPCD method JT3D.
- Data from reference 7 above; Eng. M - TF33.
- PMA Specification A-6123-A September 1970 Guaranteed Rating.
- Bogdan, Leonard and McAdams, H. T.: Analysis of Exhaust Emission Measurements. CAL Report No. CA-5007-k-1 October 15, 1971.
- Data from reference 8 above; JT3D Data not JT3C.

Table IV (Cont'd)
SURVEY OF A/C ENGINE EMISSION FACTORS

Engine	Civilian	Mode	Fuel Rate Average (1000 lb/hr)	Carbon Monoxide	Pollutant Emission Rate (lbs/1000 lb of fuel)	Unburned Hydrocarbons
J-85	--	IDLE	.65 ¹	150.0 ¹	42.0 ¹	
		NORMAL-Cruise	1.8 ¹	58.0 ¹	9.4 ¹	
		MILITARY	2.65 ¹	46.0 ¹	5.8 ¹	
		AFTERBURNER	7.70 ¹	35.0 ¹	4.0 ¹	
J-75	--	IDLE	1.7 ²	75.2 ²	41.5 ²	82.2 ²
		NORMAL-Cruise	11.3 ²	1.4 ²	.1 ²	
		MILITARY	13.2 ²	.6 ²	.5 ²	.1 ²
		AFTERBURNER	53.7 ²			
TF-39	JT4A	IDLE	1.198 ²	50.0 ²	17.0 ²	
		NORMAL-Cruise	12.42 ²			
		MILITARY	12.85 ²	3.0 ²	.3 ²	
T-56	--	IDLE	.548 ³	28.10 ³	11.92 ³	
		NORMAL-Cruise	1.908 ³	1.57 ³	.25 ³	
		MILITARY	2.079 ³	1.04 ³	.20 ³	
T-76	--	IDLE	.192 ⁴	23.78 ⁴	7.42 ⁴	
		NORMAL-Cruise	.347 ⁴	5.92 ⁴	.11 ⁴	
		MILITARY	.387 ⁴	2.28 ⁴	.064 ⁴	
O-470 R	--	IDLE	.01512 ⁵	742.5 ⁵	191.4 ⁵	
		NORMAL-Cruise	.0855 ⁵	691.66 ⁵	9.46 ⁵	
		MILITARY	.13125 ⁵	1155.8 ⁵	20.40 ⁵	
10-360	--	IDLE	.01517 ⁶	848.18 ⁶	144.50 ⁶	
		NORMAL-Cruise	.06788 ⁶	971.97 ⁶	17.40 ⁶	
		MILITARY	.0887 ⁶	1031.25 ⁶	22.47 ⁶	

Footnotes:

¹ Lazalier, G. R. and Gearhart, J. M.: Measurement of Pollutant Emissions From an Afterburning Turbojet Engine at Ground Level.

² Robson, F. L., Kesten, A. S. and Lessard, R. D.: Analysis of Jet Engine Test Cell Pollution Abatement Methods. AFWL-TR-73-18.

³ Leonard Bogdan and H. T. McAdams: Analysis of Exhaust Emission Measurements. CAL Report No. MA-5007-K-1, October 15, 1971.

⁴ Engineering Staff: "Exhaust Emissions Test Aircraft Propulsion and Auxiliary Power Gas Turbine Engines", Air Research Manufacturing Company of Arizona.

⁵ Bogdan, Leonard and McAdams, H. T.: Analysis of Exhaust Emission Measurements. CAL Report No. MA-5007-K-1, October 15, 1971. Pages 11-35.

⁶ Bogdan, Leonard and McAdams, H. T.: Analysis of Exhaust Emission Measurements. CAL Report No. MA-5007-K-1, October 15, 1971. Pages 1-108.

Table IV (Cont'd)
SURVEY OF A/C ENGINE EMISSION FACTORS

Engine	Civilian	Mode	Fuel Rate Average (1000 lb/hr.)	Particulates	Pollutant Emission Rate (lbs/1000 lb of fuel)	Nitrogen Oxides
J-85		IDLE	.65 ¹		5.3 ¹	
		NORMAL-Cruise	1.8 ¹		3.6 ¹	
		MILITARY	2.65 ¹		5.4 ¹	
		AFTERBURNER	7.70 ¹		3.1 ¹	
J-75		IDLE	1.7 ²	.3 ²	1.07 ^{2,3}	.9 ^{2,3}
		NORMAL-Cruise	11.3 ²		11.9 ²	
		MILITARY	13.2 ²	.6 ²	1.2 ^{2,3}	15.2 ²
		AFTERBURNER	53.7 ²	1.5 ²		
TF-39		IDLE	1.198 ²	.1 ²	5.36 ^{2,3}	
		NORMAL-Cruise	12.42 ²			
		MILITARY	12.85 ²	.1 ²	42.8 ^{2,3}	
T-56		IDLE	.548 ⁴		3.93 ⁴	
		NORMAL-Cruise	1.908 ⁴		11.11 ⁴	
		MILITARY	2.079 ⁴		10.98 ⁴	
T-76		IDLE	.192 ⁵		7.35 ⁵	
		NORMAL-Cruise	.347 ⁵		9.88 ⁵	
		MILITARY	.387 ⁵		10.27 ⁵	
U-470 R		IDLE	.01512 ⁶		1.02 ⁶	
		NORMAL-Cruise	.0855 ⁶		9.37 ⁶	
		MILITARY	.13125 ⁶		1.11 ⁶	
F0-360		IDLE	.01517 ⁷		1.09 ⁷	
		NORMAL-Cruise	.06788 ⁷		6.60 ⁷	
		MILITARY	.0887 ⁷		5.32 ⁷	

Footnotes:

- ¹ Lenzler, G. R. and Gearhart, J. M.: Measurement of Pollutant Emissions From an Afterburning Turbojet Engine at Ground Level.
- ² Bobgan, Leonard and McAdams, H. T.: Analysis of Jet Engine Test Cell Pollution Abatement Methods. AFWL-TR-73-18.
- ³ Bobgan, Leonard and McAdams, H. T.: Analysis of Exhaust Emission Measurements. CAL Report No. MA-5007-K-1. October 15, 1971.
- ⁴ Bobgan, Leonard and McAdams, H. T.: Analysis of Exhaust Emission Measurements. CAL Report No. MA-5007-K-1. October 15, 1971.
- ⁵ Engineering Staff: "Exhaust Emissions Test Air Research Aircraft Propulsion and Auxiliary Power Gas Turbine Engines", Air Research Manufacturing Company of Arizona.
- ⁶ Bobgan, Leonard and McAdams, H. T.: Analysis of Exhaust Emission Measurements. CAL Report No. MA-5007-K-1. October 15, 1971. Page 11-35.
- ⁷ Bobgan, Leonard and McAdams, H. T.: Analysis of Exhaust Emission Measurements. CAL Report No. MA-5007-K-1. October 15, 1971. Page 1-108.

b. Fuel Flow Rate

The fuel flow rate is one of the critical parameters of jet engine plume testing that can be controlled.

The fuel flow rates presented in table IV for the various modes varied among individual tests by as much as 500 to 1000 pounds per hour. This variance in fuel flow rate which may or may not be intentional can affect the resultant emission factor considerably. Thus, applying this emission factor in an individual case will not represent the actual emission if the operating mode for some aircraft has a fuel flow rate much different than the fuel flow rate at which emission measurements were taken.

c. Exhaust Emission Sampling

Problems and limitations of exhaust sampling fall into two general areas; these are (a) variability of sample collection methods, and (b) variability of analytical procedures used to determine concentration of material in the gas stream.

The first of these, variability of sample collection method, can affect the measured emissions of all pollutants. The most critical single variables for sampling of gaseous material are the temperature and location of the sampling probe. Temperature is critical in that some of the material may condense out on the sampling probe and not be detected or conversely a further chemical reaction can take place in the probe or line. Location of the sampling probe is critical in obtaining a representative sample. This cannot be accurately done by equal area methods due to the very high and unpredictable gradients of pollutants in the exhaust stream.

The second, variability of analytical procedures, is critical, especially when considering the concentration of particulate matter. Four major methods are used to obtain samples for particulate mass analysis. The Environmental Protection Agency (EPA), Bay Area Air Pollution Control District (BAAPCD), the Los Angeles Air Pollution Control District (LAAPCD), and dilution tube methods all give considerably different results. These differences occur because of differences in sampling and analysis of the collected material. Problems are associated with the lack of a specific definition of which condensable material should be included in particulate matter category. Therefore, one has to be very careful when comparing particulate emission results.

d. Lack of Data

This problem covers the broad area from not having sufficient data to determine if the emission factor is statistically significant to the complete lack of any test data. For example, all of the tests conducted in the civilian sector were on non-afterburning jet engines and did not include particulate mass measurements. The three of four individual tests that have been conducted on afterburning military engines are hardly sufficient to draw a conclusion about the effect of afterburners on the ambient air quality.

e. Cost Limitations

Source testing of jet engines is still in the early development stages, and therefore a costly venture at best. In addition to sampling and analysis procedure difficulties, the costs in terms of facilities and manpower to get statistically significant data on the many operational modes (including afterburner) of jet engines are considerable. The Air Force actively uses 21 basic turbine models of which 16 are either turbojets or turbofans. Many tests are required in each mode of each aircraft before a meaningful pollution emission factor can be obtained. Overall testing costs are not only in terms of manpower for the test, but also for the disruption of a standardized test cell or other maintenance operations.

3. FUTURE EMISSION FACTORS

The Environmental Protection Agency has published in the Federal Register a sampling procedure to obtain emission data for turbine and piston aircraft engines and auxiliary power units. The procedure outlined does not presently include a provision for directly sampling particulate matter and the problems associated with its collection and analysis. Instead the procedures employ the smoke-number method for emission standard compliance, which temporarily avoids the particulate matter question. This avoidance of the particulate matter question could create considerable problems, especially if the engine is being tested in a test cell. It is entirely possible that an engine could meet the smoke-number criterion at the exhaust nozzle but still be in violation of the Ringelman standard or a process weight standard at the exhaust port of a test cell, due to further reaction with augmentation air or visibility path length differences in the test cell exhaust.

The EPA proposed standard also does not currently define sampling procedures for engine afterburner operation which is at this time entirely a military

application of jet engine technology (except for proposed civilian supersonic transport engines). Standard techniques in these two areas will have to be developed before consistent emission factors can be determined for military aircraft engines.

SECTION V

EFFORTS TO MEASURE AIRCRAFT EMISSION FACTORS

As a result of inadequate data on USAF aircraft pollution emissions, a new project was initiated in FY 73 to perform measurements on large numbers of USAF aircraft engines. The goals of this project are to improve the very limited data base of current military aircraft emissions, to supply particulate mass loading data which is generally absent from previous measurements, to study engine series to engine series variability, and to correlate pollution measurements made at the exit plane of the aircraft engine exhaust with measurements made at the exit plane of a test cell exhaust.

1. ENGINE PRIORITIES

A USAF aircraft engines priority list was prepared according to the need for pollution data (table V). The percentage of engine hours flown, availability of previous emission measurements, and the likelihood of local community impact were used as priority criteria.

The actual sequence of measurements may have to vary, however, due to location and difficulty constraints. For example, J-79, J-75, J-57, TF-30, TF-33, and TF-41 engines are overhauled at Tinker AFB; T-56, T-39, and all auxiliary power unit engines are overhauled at Kelly AFB; and J-85 and J-69 engines are overhauled at contractor facilities. Certain engines may also present special sampling difficulties and may be deferred until completion of other more routinely measured engines. An example is the TF-30, a mixed flow engine which is difficult to sample due to the large volume of air which by-passes the combustion process but is internally mixed with the exhaust.

Tests of approximately 10 engines per model are needed to obtain data which is not biased by engine to engine variability. Differences between engine series (i.e., T-79-15 versus J-79-17) are also to be determined. From past experience, engine testing run times of up to 5 hours per engine can be expected in order to obtain representative pollution levels over the strong gradients existing in the exhaust stream. A proposed testing schedule is presented in figure 2.

Table V
A/C ENGINE TESTING PRIORITY LIST

Priority	Engine Type	Aircraft Types
1	J-57	B-52 (C-G Models) KC-135A, F-100, F-101 F-102
2	J-69	T-37
3	J-79	F-4, F-104
4	J-85	T-38
5	TF-33	B-52H, C-141
6	T-56	C-130
7	TF-30	F-111
8	J-75	F-105, F-106
9	J-33	T-33
10	TF-41	A-7
11	TF-39	C-5
12	J-60	T-39
13	T-76	OV-10
14	J-65	B-57
15	JT-8D	C-9

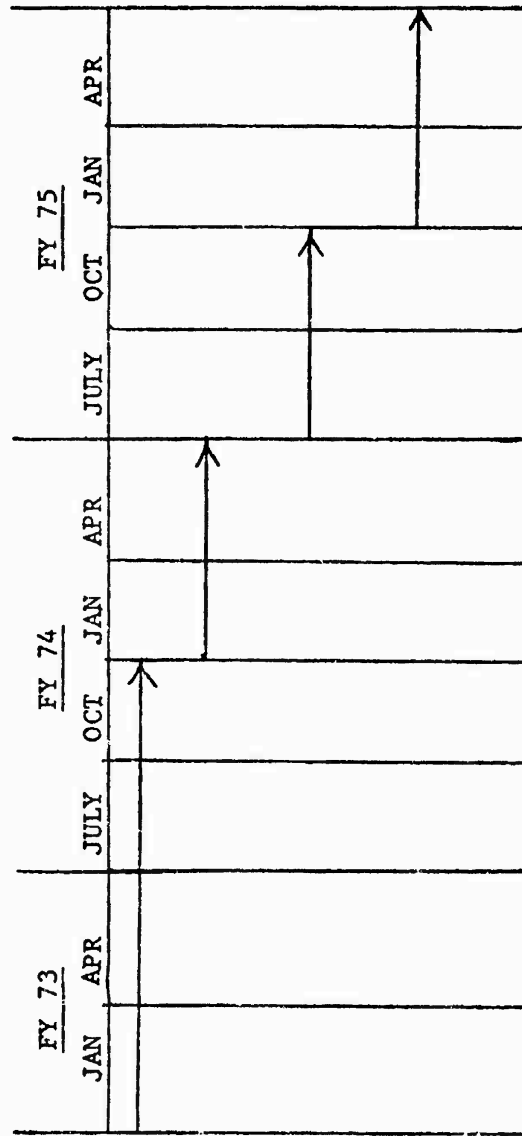

- * TRAILER INSTRUMENTATION
- * 3 ENGINE MODELS
(NON A/B - 30 ENGINES)
- * 3 ENGINE MODELS
(NON A/B - 30 ENGINES)
- * 3 MODELS IN A/B
(9 ENGINES)

Figure 2. Proposed Engine Testing Schedule

2. MEASUREMENT LOCATIONS

Arnold Engineering Development Center (AEDC) was a candidate location for the testing of all engines. AEDC has both the required concrete test facilities and outdoor test stands needed for such testing. However, due to the extreme difficulty and expense in acquiring, shipping, and installing large numbers of operational engines, the decision was made to construct an emission measurement bus which could be driven to engine overhaul facilities where engines are most available. Tinker AFB, Kelly AFB, and the J-85 and J-69 contractor facilities are the most desirable testing locations. Hq AFLC support for the required additional engine running time at these locations is currently being sought.

3. MEASUREMENT TECHNIQUES

Emission measurement techniques are generally those as detailed in the Society of Automotive Engineer's "Aerospace Recommended Practice" #1179 for smoke measurement and #1256 for gaseous emission measurement. Sampling probes, heated transport lines, and continuous measurement instrumentation will be used (figure 3, table VI). While remote instrumentation for "in-situ" measurements would be highly desirable, the long term development program to accurately measure the pollutants of interest and to eliminate all interferences, dictated that the currently accepted instrumentation be used. Correlations between sampling line and "in-situ" measurements should be in future efforts.

There is currently no ARP measurement technique to obtain particulate mass emissions although strong efforts to develop an acceptable technique are underway. The dilution tube and smoke-number methods will both be used in initial testing. The EPA technique for dry particulates and the LAAPCD technique for total particulates (includes water and solvent soluble components) may be used sparingly to obtain some correlation with past studies.

Emission measurements in engine afterburning modes present major sampling difficulties. While all other engine modes can be sampled at the exhaust plane of an engine inside a maintenance test cell, the afterburning mode has chemical reactions occurring downstream from the engine exhaust. Also, abnormal quenching of the reaction caused by the test cell itself makes measurements at the exit plane of a test cell highly suspect. Consequently, measurements in the A/B mode will be taken downstream from engines in an open outdoor "test stand." Data collection is tentatively planned in early FY 75 to take advantage of a concurrent program at AFAPL for the development of techniques for afterburning emission

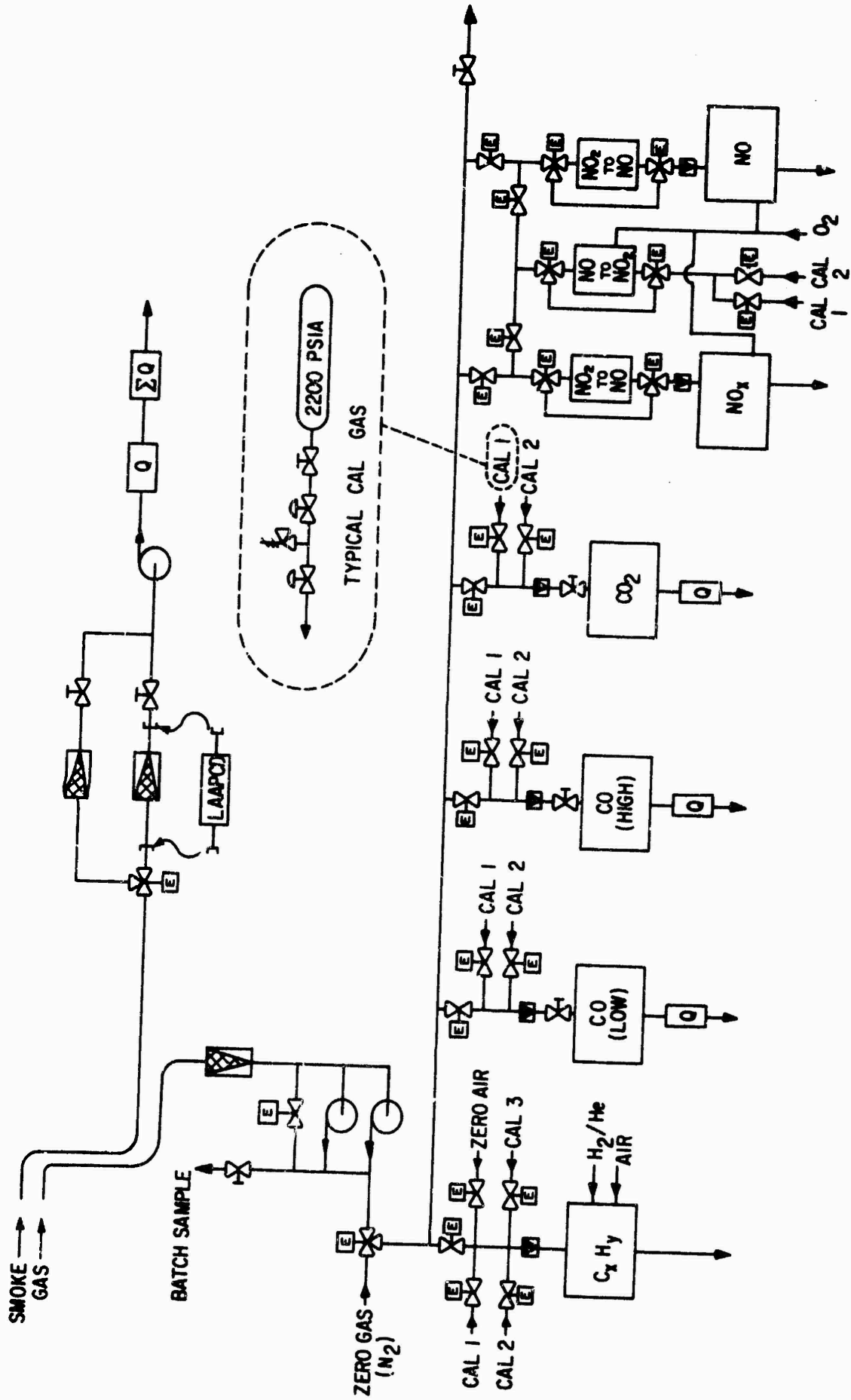

Figure 3. Engine Testing Equipment Schematic

Table VI
MOBILE EMISSION LAB INSTRUMENTATION*

EMISSION SPECIES	SENSING METHOD	INSTRUMENT TYPE	FULL-SCALE RANGES
C _x H _y	Flame Ionization	Beckman 402	5 to 250,000 ppmC in 8 steps
CO	Nondispersive Infrared	Beckman 865 Beckman 864	100, 300, 1000 ppmv 1000, 3000, 7000 ppmv
CO ₂	Nondispersive Infrared	Beckman 864	5, 10, 20 percent
NO	Chemi-Illuminescence	TECO 10B	2.5 to 10,000 ppmv in 8 steps
NO _x	Chemi-Illuminescence	TECO 10B with Converter	2.5 to 10,000 ppmv in 8 steps
Smoke	ARP 1179	Filter Reflectometer	---
Particulates	Gravimetric; Not Determined for Aeromatics and Sulfates.	Environmental Research	---
Dry Particulates	Gravimetric	Filter and Wet Test Meter	---
Wet Particulates	LAAPCD	Impactors and Wet Test Meter	---

*Prepared by Mr. Donald Davidson, ARO Project Engineer for AEDC.

measurements. The AFAPL project will intensively study one engine each of the J-79, J-85, and F101 engine models. The survey program outlined here will then perform briefer measurements on larger numbers of the above engines as well as possible measurements on the J-75, J-57, and TF-30 engines in the A/B mode.

SECTION VI

EFFORTS TO OBTAIN AIRCRAFT LANDING AND TAKE-OFF CYCLES

Obtaining an accurate characterization of USAF aircraft operational procedures is equally as important as obtaining engine emission factors when performing any kind of analysis of aircraft effects on air quality. Operations are characterized by the total number of takeoffs and landings for a given aircraft model (which can be readily obtained from records) and an accurate description of average aircraft landing and takeoff (LTO) cycles. Average LTO cycle information is not now available for USAF aircraft and is therefore being proposed in the following sections.

1. LTO CYCLE COMPONENTS

Three essential components are required to describe the LTO cycle for each aircraft. The aircraft mode of operation (as a function of engine operation such as fuel flow), average time in each of the aircraft modes, and location of aircraft in each of the aircraft modes are described separately.

a. Aircraft Modes

Aircraft modes of operation must be categorized in a way that emission information can be accurately compiled to describe all of the actions taken by aircraft. Each category must have only one significant engine thrust setting since the engine emission factors are based on thrust (i.e., fuel flow). A nine-category aircraft LTO cycle is proposed for USAF usage as pictured in figure 4. The nine categories are intended to be specific for each aircraft type but generally averaged over all Air Force bases. If two aircraft types have vastly different operating cycles, they may be handled separately. Climb and approach are defined as being only below a 3000-foot actual ground level (AGL) which is in agreement with EPA studies.

Two additional categories are needed to completely describe all emissions in a cycle. Category 10 describes aircraft "touch and go" operations which are used as a training method at many Air Force bases. Operations will generally have the same engine fuel flows and power settings as category 6, approach from 3000 feet, and category 5, climb to 3000 feet, but must be counted separately when compiling total aircraft operations.

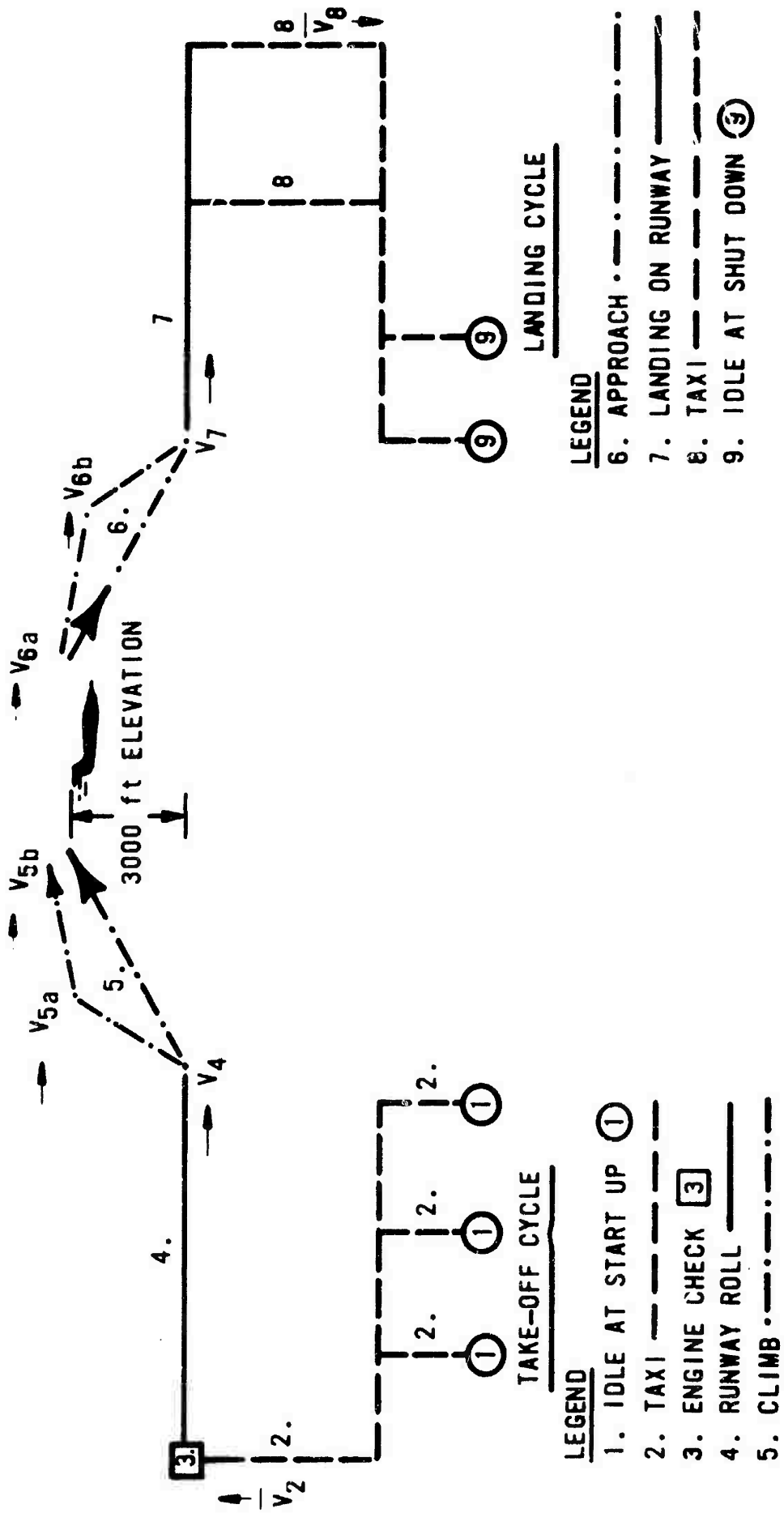

Figure 4. Landing and Take-Off Cycles

Category 11 describes the amount of raw fuel which is spilled, dumped, or vented in an average LTO cycle. This value will vary considerably from aircraft to aircraft and by operating procedures between similar aircraft.

b. Time Per Aircraft Mode

For the first 9 aircraft mode categories described above, an average time per operation is required. Some of the times such as taxi duration before takeoff are more a function of airbase design than of aircraft type. Other times such as the duration of climb out to 3000 feet are almost exclusively a function of aircraft type. Despite these variables, overall average times for each LTO category must be obtained per aircraft.

c. Locations Per Aircraft Mode

When determining the effects of aircraft on air quality, the location where pollutants are emitted is quite important. Only some of this information is considered as part of the generalized LTO cycle per aircraft type. Relationships to describe the length of runway roll on takeoff, climb rates, and descent rates and aircraft speeds can be developed independently from the area of concern. Other data such as the location of parking ramps, taxiways, runways, as well as wind frequencies to describe runway directions, will have to be described specifically for each airbase of interest.

2. LTO DATA COLLECTION SHEETS

Standard data sheets for the collection of necessary LTO cycle information are proposed in tables VII (fixed wing aircraft) and VIII (rotary wing aircraft). One data sheet for each aircraft type is needed. The 11 aircraft mode categories are in chronological sequence of the LTO cycle. Engine modes are most accurately described in fuel flow (pounds per minute), but may be converted from percent of maximum thrust which is the normal indicator in the cockpit. This data will eventually be reduced to engine mode categories of idle, cruise, military (full rated thrust), and maximum afterburner.

Distance values on this general data sheet are only needed in the blank columns. All other distances vary with airbase design and therefore must be obtained specifically for the local area which is under investigation.

Raw fuel loss during ground operations has proven to be significant in some civilian aircraft operations. Obtaining accurate estimates of quantities lost and aircraft modes during loss will help define the need for any Air Force

Table VII

LANDING AND TAKE-OFF SAMPLE DATA SHEET-FIXED WING AIRCRAFT

AIRCRAFT TYPE _____
 COMMAND/BASE _____

AIRCRAFT MODE	ENGINE MODE (LBS FUEL/NR)	TIME* (SEC)	DISTANCE** (FT)	SPEED*** (FT/SEC)	ADDITIONAL DATA
1. IDLE AT START UP					
2. TAXI BEFORE TAKE-OFF					
3. ENGINE CHECK AT RUNWAY END					
4. RUNWAY ROLL					AVG TAKE-OFF WEIGHT _____
5a. CLIMBOUT-STEP #1					STEP #1 HEIGHT _____ AVG CLIMB ANGLE _____
b. CLIMBOUT TO 3000° AGL-STEP #2					AVG CLIMB ANGLE _____
6a. APPROACH FROM 3000° AGL-STEP #1					AVG DESCENT ANGLE _____
b. APPROACH FROM-STEP #2					STEP #2 HEIGHT _____ AVG DESCENT ANGLE _____
7. LANDING ON RUNWAY					DRAG CHUTE: YES _____ NO _____ % OF TIME USED _____
8. TAXI AFTER LANDING					
9. IDLE AT SHUTDOWN					
10. TOUCH & GO OPERATIONS			(ON RUNWAY)		

11. AMOUNT OF FUEL LOST (SPILLED, VENTED, PURGED) DURING FOLLOWING OPERATION

A. REFUELING _____ C. TAXI _____ E. ENGINE SHUT-DOWN _____
 B. ENGINE START-UP _____ D. TAKE-OFF _____ F. OTHER _____

* WHERE POSSIBLE, CALCULATE: TIME - DISTANCE ÷ AVG SPEED

** DISTANCE HORIZONTAL COMPONENT ONLY

*** SPEED AS INDICATED IN ATTACHED FIGURE: \bar{V} -AVG SPEED, V-INSTANTANEOUS SPEED

Table VIII

LANDING AND TAKE-OFF SAMPLE DATA SHEET-ROTARY WING AIRCRAFT

Aircraft Type _____ Base _____

Mode	Time in Seconds		Engine Mode	Distance	Additional Data
	Min.	Max.			
Idle at Start up				N/A	
Run-up or Engine Test				N/A	
Ascent					Avg. Takeoff Weight _____ Speed _____ Acceleration _____
Level Flight				N/A	
Descent					Avg. Landing Weight _____ Speed _____ Deceleration _____
Idle at Shutdown				N/A	

When does fuel venting from the engines occur?
How much fuel is vented?

concern. Accidental full spills should also be noted by indicating average quantities and frequency of occurrence.

Additional data, such as average aircraft velocities at lift-off, average velocities at touchdown, average descent angles, and average climb angles will be used to characterize the aircraft location throughout the LTO cycle. The touch and go category assumes aircraft modes as described in the approach and climb out categories with only a momentary touchdown of the aircraft wheels on the runway. Practice cycles which are typically different should be described (such as "low fly-overs" where the aircraft does not descend below 50 feet AGL, or "touch and go's" with a 400-foot or greater runway roll).

REFERENCES

1. "Control of Air Pollution From Aircraft and Aircraft Engines," Federal Register, Volume 38, Number 136, Part II, 17 July 1973.
2. Lavalley, William F, Commander, USN, "Procurement of Jet Aviation Fuel by DOD," Defense Systems Analysis, 1972.
3. "Jet Fuel Requirements and How They Will Be Met in 1968 - 1975," FAA Staff Study, March 1968.
4. Blazowski, W. S. and Henderson, R. F., Assessment of Pollution Measurement and Control Technology and Development of Pollution Reduction Goals for Military Aircraft Engines, AFAPL-TR-72-102, November 1972.
5. Jones, Holmes, and Sampson, "The Federal Aircraft Emission Control Program: Standards and Their Basis," Air Pollution Control Association Paper 73-241 presented at the 66th Annual APCA Meeting, 24 to 28 June 1973.
6. McAdams, H. T., Aanalysis of Aircraft Exhaust Emission Measurements: Statistics and Measurements, Cornell Aeronautical Laboratory, Inc., Report NA-5007-K-1 for EPA Contract 68-04-0040, 9 November 1971.
7. Executive Order 10779, Eisenhower, Dwight D., 20 August 1958.
8. Public Law 90-148, Title II National Emission Standards Act, Section 2116, 21 November 1967.
9. Clean Air Act (42 U.S.X. 1857 et seq.) includes the Clean Air Act of 1963 (P.L. 88-206) and amendments made by the Motor Vehicle Air Pollution Control Act (P.L. 89-272) (October 20, 1965), the Clean Air Act Amendments of 1966 (P.L. 89-675 (October 15, 1966), the Air Quality Act of 1967 (P.L. 90-148) (November 21, 1967), and the Clean Air Act Amendments of 1970 (P.L. 91-604) (December 31, 1970).
10. Ibid, Section 231.
11. Executive Order 11507, Nixon, Richard M., 4 February 1970.
12. Federal Register, Volume 37, Number 239, Part II, 12 December 1972.
13. Federal Register, Volume 37, Number 239, Part III, 12 December 1972.
14. Nature and Control of Aircraft Engine Exhaust Emissions, NREC Report No. 1134-1, Northern Research and Engineering Corporation, Cambridge, Massachusetts, November 1968, page 24.
15. Ibid, Page 110.
16. George, R. E. and Burlin, R. M., Air Pollution From Commercial Jet Aircraft in Los Angeles, County, Air Pollution Control Division, County of Los Angeles, April 1960.

REFERENCES (Cont'd)

17. Smith, D. S., Sawyer, R. F., and Starkman, E. S., "Oxides of Nitrogen From Gas Turbines," APCA Journal, Volume 18, No. 1, January 1968.
18. Lozano, E. R., Melvin, W. W., and Hochheiser, S., "Air Pollution Emissions from Jet Engines," APCA Journal, Volume 18, No. 6, June 1968.
19. Aircraft Engine Group, General Electric Company, direct communication, 30 July 1968.
20. Allison Division, General Motors Corporation, direct communication, 7 August 1968.
21. Pratt & Whitney Aircraft Division, United Aircraft Corporation, direct communication, 3 October 1968.
22. Pratt & Whitney Air Craft Division, United Aircraft Corporation, direct communication, 18 June 1968.
23. Aero Engine Division, Rolls-Royce Limited, direct communication, 9 September 1968.
24. Burnett, R. D., Preliminary Report Jet Engine Test Cell Emissions, USAF Environmental Health Laboratory, McClellan AFB, CA, Report No. 70M-37 (Project No. E-70-33), December 1970, page 1.
25. The Potential Impact of Aircraft Emissions Upon Air Quality, NREC Report No. 1167-1, Northern Research and Engineering Corporation, Cambridge, MA, December 29, 1971.
26. Ibid, pages 1-4.
27. Burnett, R. D., Noise and Air Pollution Emissions from Noise Suppressors for Engine Test Stands and Aircraft Power Check Pads, USAF Environmental Health Laboratory, McClellan AFB, CA, Report No. 71M-19.
28. Lazalier, G. R. and Gearhart, J. W., Measurements of Pollution Emissions From an Afterburning Turbojet Engine at Ground Level, Part II--Gaseous Emissions, AEDC-TR-72-70, August 1972.
29. Lazalier, G., Letter Report on Gaseous Emissions from the J-57-F21A Engine, ARO Inc. (AEDC), May 1972.
30. Bahr, D., "Exhaust Emission Characteristics--G.E. Engines," AFAPL correspondence, March 1971.
31. Dodd, R., USAAMRDL/SAVDL-EV-PP, personal correspondence.