

AD-770 195

BOUND-BOUND RADIATION/COLLISIONAL  
RADIATIVE RECOMBINATION IN OXYGEN  
AND NITROGEN PLASMAS

Larry A. Jones, et al

Naval Research Laboratory

Prepared for:

Defense Nuclear Agency

24 September 1973

DISTRIBUTED BY:

**NTIS**

National Technical Information Service  
U. S. DEPARTMENT OF COMMERCE  
5285 Port Royal Road, Springfield Va. 22151

UNCLASSIFIED

SECURITY CLASSIFICATION OF THIS PAGE (When Data Entered)

AD 770 195

REPORT DOCUMENTATION PAGE		READ INSTRUCTIONS BEFORE COMPLETING FORM
1. REPORT NUMBER DNA 3163T	2. GOVT ACCESSION NO.	3. RECIPIENT'S CATALOG NUMBER
4. TITLE (and Subtitle) BOUND-BOUND RADIATION/COLLISIONAL RADIATIVE RECOMBINATION IN OXYGEN AND NITROGEN PLASMAS		5. TYPE OF REPORT & PERIOD COVERED Topical Report for Period 1 January 1973-30 June 1973
7. AUTHOR(s) Larry A. Jones Hans R. Griem Edgar A. McLean		6. PERFORMING ORG. REPORT NUMBER
9. PERFORMING ORGANIZATION NAME AND ADDRESS Naval Research Laboratory Washington, D. C. 20375		8. CONTRACT OR GRANT NUMBER(s) DNA MIPR 73-636 ARPA Order 1433/7/Task 3E50
11. CONTROLLING OFFICE NAME AND ADDRESS Director Defense Nuclear Agency Washington, D. C. 20305		10. PROGRAM ELEMENT, PROJECT, TASK AREA & WORK UNIT NUMBERS DNA SUBTASK M99 QAN HI 002-03
14. MONITORING AGENCY NAME & ADDRESS (if different from Controlling Office)		12. REPORT DATE 24 September 1973
		13. NUMBER OF PAGES 22
		15. SECURITY CLASS. (of this report) UNCLASSIFIED
		16. DECLASSIFICATION/DOWNGRADING SCHEDULE
16. DISTRIBUTION STATEMENT (of this Report)  Approved for public release; distribution unlimited.		
17. DISTRIBUTION STATEMENT (of the abstract entered in Block 20, if different from Report)		
18. SUPPLEMENTARY NOTES		
19. KEY WORDS (Continue on reverse side if necessary and identify by block number)  Plasma Physics Bound-Bound Radiation Oxygen-Nitrogen Plasma		
20. ABSTRACT (Continue on reverse side if necessary and identify by block number)  An existing $\theta$ -pinch device has been modified to produce a low density, slowly decaying, nonthermal plasma. Using this plasma as a light source, the absolute intensity of visible line radiation originating, via dipole transitions, from the upper levels of interest can be measured. These measurements in conjunction with known atomic transition probabilities directly yield the population number densities of these upper levels. Of course, to		

FORM DD 1 JAN 73 1473 EDITION OF 1 NOV 65 IS OBSOLETE

UNCLASSIFIED

SECURITY CLASSIFICATION OF THIS PAGE (When Data Entered)

Reproduced by  
**NATIONAL TECHNICAL  
 INFORMATION SERVICE**  
 U S Department of Commerce  
 Springfield VA 22151

**UNCLASSIFIED**

**SECURITY CLASSIFICATION OF THIS PAGE(When Data Entered)**

20. Abstract (Continued)

make these measurements meaningful, the plasma parameters; i. e., electron density, temperature, and effective optical length, must be known.

Thus far, laser scattering has been used as a diagnostic tool at early times. The electron density and temperature have been measured versus time over the range  $10^{15} - 10^{14} \text{ cm}^{-3}$  and 2.0 - 0.8 eV, respectively. Number densities of three levels of atomic nitrogen have been measured at these early times and show a marked time dependent discrepancy with those calculated from the Saha equation.

**UNCLASSIFIED**

**SECURITY CLASSIFICATION OF THIS PAGE(When Data Entered)**

## TABLE OF CONTENTS

<u>Section</u>		<u>Page</u>
I	Introduction - - - - -	3
II	Apparatus modifications - - - - -	4
III	Measurements (to date) - - - - -	7
IV	Conclusions - - - - -	17
V	Future work - - - - -	18
	A. 1st Quarter - - - - -	18
	B. 2d Quarter - - - - -	18
	C. 3d Quarter - - - - -	18
	D. 4th Quarter - - - - -	18

## LIST OF ILLUSTRATIONS

<u>Figure</u>		<u>Page</u>
1	Hybrid schematic of $\theta$ -pinch electrical circuit -----	5
2	Current flowing in $\theta$ -pinch main coil after addition of inductors and crowbar switches to main bank -----	6
3	Schematic of optical detection system used to take spectra and to measure absolute line intensities-----	8
4	Spectrum of emission by the $\theta$ -pinch device when filled to a pressure of 10 $\mu$ with gaseous nitrogen -----	9
5	Time resolved emission by the various species present in the pure gaseous nitrogen discharge -----	10
6	Electron density and electron temperature plotted versus time after initiation of main bank discharge-----	12
7	Upper level number density divided by the level degeneracy plotted versus level ionization energy-----	13
8	Species number densities of electrons, $N_e$ , atomic ionized nitrogen, $N_{N^+}$ , and molecular ionized nitrogen, $N_{N_2^+}$ plotted versus time after initiation of main bank discharge -----	16

## SECTION I

### INTRODUCTION

The experimental program to determine the bound-bound emissivity in the near infrared (1-10  $\mu\text{m}$ ) of a low density, decaying, nonthermal nitrogen and/or oxygen plasma got underway at Naval Research Laboratory in mid-January 1973. Our approach to the problem was to modify an existing  $\theta$ -pinch device to produce a slowly decaying plasma (on the order of 0.1 msec). Using the plasma as a light source, we can measure the absolute intensity of visible radiation originating via dipole transitions from upper levels of interest. This information in conjunction with the known atomic transition probabilities directly yields the number densities of these upper levels. From this we can then calculate the infrared bound-bound emissivity due to dipole transitions from these upper levels to the appropriate lower levels.

It should be pointed out that in order to make these measurements meaningful the plasma parameters; i. e., electron density, temperature, and effective length, must be known. Thus, a major part of our effort must be directed toward plasma diagnostics.

## SECTION II

### APPARATUS MODIFICATIONS

The original  $\theta$ -pinch device gave plasma parameters unsuitable for this study, electron density  $\sim 10^{17}$  cm<sup>-3</sup>, electron temperature  $\sim 100$  eV, and plasma lifetime on the order of microseconds. We modified this apparatus by adding large inductors and crowbar switches to the main bank. The main bank, instead of heating the plasma, now acts as a containment bias field. A hybrid schematic of the electrical circuitry is shown in Figure 1.

The mode of operation is as follows:

1. A 0.12  $\mu$ F capacitor charged to  $\sim 16$  kV is discharged through small side coils. This fast ringing discharge, called the pre-preheater, is designed to partially ionize and heat the gas in the tube.
2. About 5  $\mu$ sec later a 2  $\mu$ F capacitor charged to  $\sim 16$  kV is discharged through the main  $\theta$ -pinch coil. This is called the preheater. It heats the plasma still further, to about 3 eV, and nearly totally ionizes it.
3. Six microseconds later the main bank, charged to  $\sim 17$  kV and having a total capacity of 250  $\mu$ F, is discharged through the main  $\theta$ -pinch coil and the large inductor. This produces a large bias field ( $\sim 9$  kG) inside the coil which tends to hold the plasma away from the tube walls. This is important because the plasma by being confined to the center of the tube during its initial hot stage will not become contaminated with ablated wall material. Later, as the plasma cools, it no longer is capable of ablating the quartz walls of the tube, and thus containment is not critical.
4. When the current reaches its peak, about 16.5  $\mu$ sec after the discharge of the main bank is initiated, crowbar switches are triggered. These essentially short out the main bank capacitors. Thus, the current will continue to flow through the circuit fed by inductive energy storage and exponentially damped by ohmic losses until the switches stop conducting. A current trace is shown in Figure 2, and as can be seen this happens about 240  $\mu$ sec after initiation of a main bank discharge.

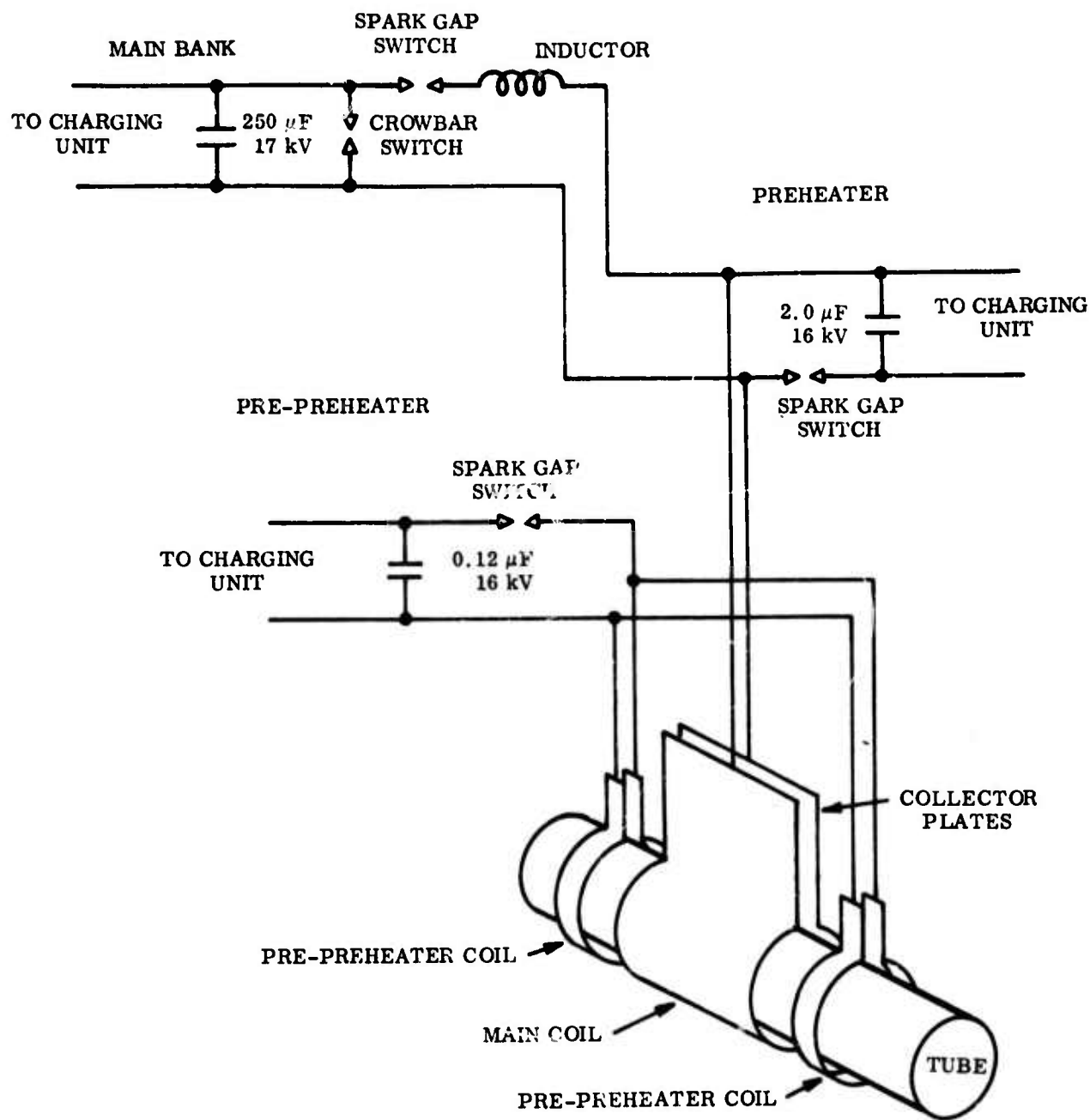

Figure 1. Hybrid schematic of  $\theta$ -pinch electrical circuit.

A further modification to the  $\theta$ -pinch device was to put a longer coil on it. Since our optical measurements are to be done axially, the longest possible plasma length will enable us to detect optical radiation from the lowest possible density.

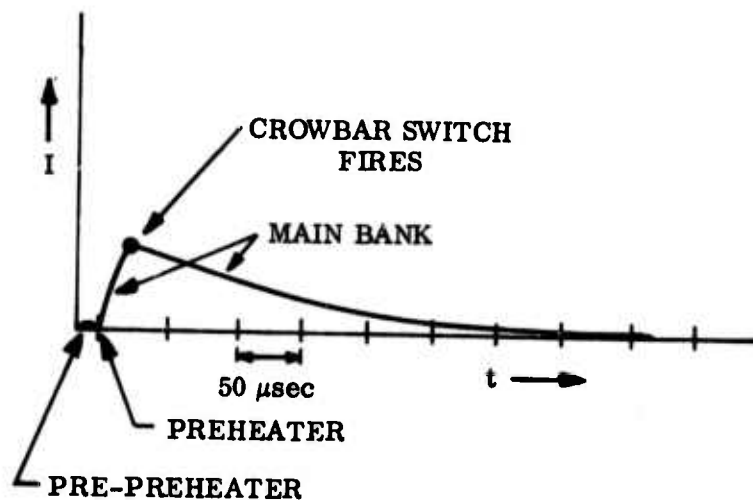

Figure 2. Current flowing in  $\theta$ -pinch main coil after addition of inductors and crowbar switches to main bank.

## SECTION III

### MEASUREMENTS (TO DATE)

Once satisfactory current characteristics were obtained in the  $\theta$ -pinch device, diagnostic measurements were undertaken. Because of the ease in working with nitrogen, we felt all our diagnostics should first be tried with nitrogen. Thus, to date, we have results with a pure nitrogen fill gas at 10  $\mu$  of mercury pressure.

We first took a time integrated spectrum of the light being emitted by our plasma with the optical detection setup shown in Figure 3. Upon identifying the lines of the time integrated emission spectrum shown in Figure 4, we found that the plasma was relatively impurity free emitting mainly atomic nitrogen, ionized atomic nitrogen, molecular nitrogen, and ionized molecular nitrogen lines ( $N$ ,  $N^+$ ,  $N_2$ ,  $N_2^+$ ).

Our next task was to measure the time variation of the various emitting species in our plasma. Some oscilloscope traces are shown in Figure 5. Notice how the neutral nitrogen line at 4935  $\text{\AA}$  decays slowly with time while the traces of the ionized atomic nitrogen line at 4895.1  $\text{\AA}$  quickly decays. It is important to note here that the emission from the molecular nitrogen ion bandhead at 3914  $\text{\AA}$  rapidly decays at first but then levels off for about 40  $\mu$  sec before decaying further. This foot in the light emission versus time may indicate a competition between production and destruction processes.

As a test of our experimental method, we decided to take measurements at early times when the electron density and temperature are high enough to insure that some detectable neutral atom levels will be in collisional (Saha) equilibrium with the ground state of the ion. Laser scattering was done by directing the beam of a pulsed ruby laser down the axis of our tube and detecting scattered light perpendicular to this beam through a slot in the  $\theta$ -pinch coil. The resulting Doppler-broadened profiles were scanned shot-to-shot with a monochromator. Calibration of the system to get the absolute value of Thomson-scattered light was done using Rayleigh scattering from molecular nitrogen at known pressure.

OPTICAL DETECTION

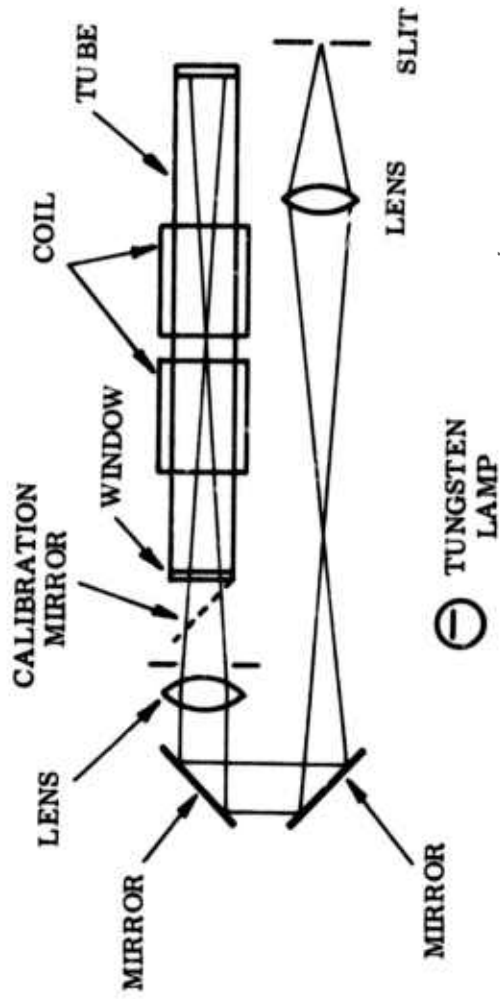

Figure 3. Schematic of optical detection system used to take spectra and to measure absolute line intensities.

Reproduced from  
best available copy.

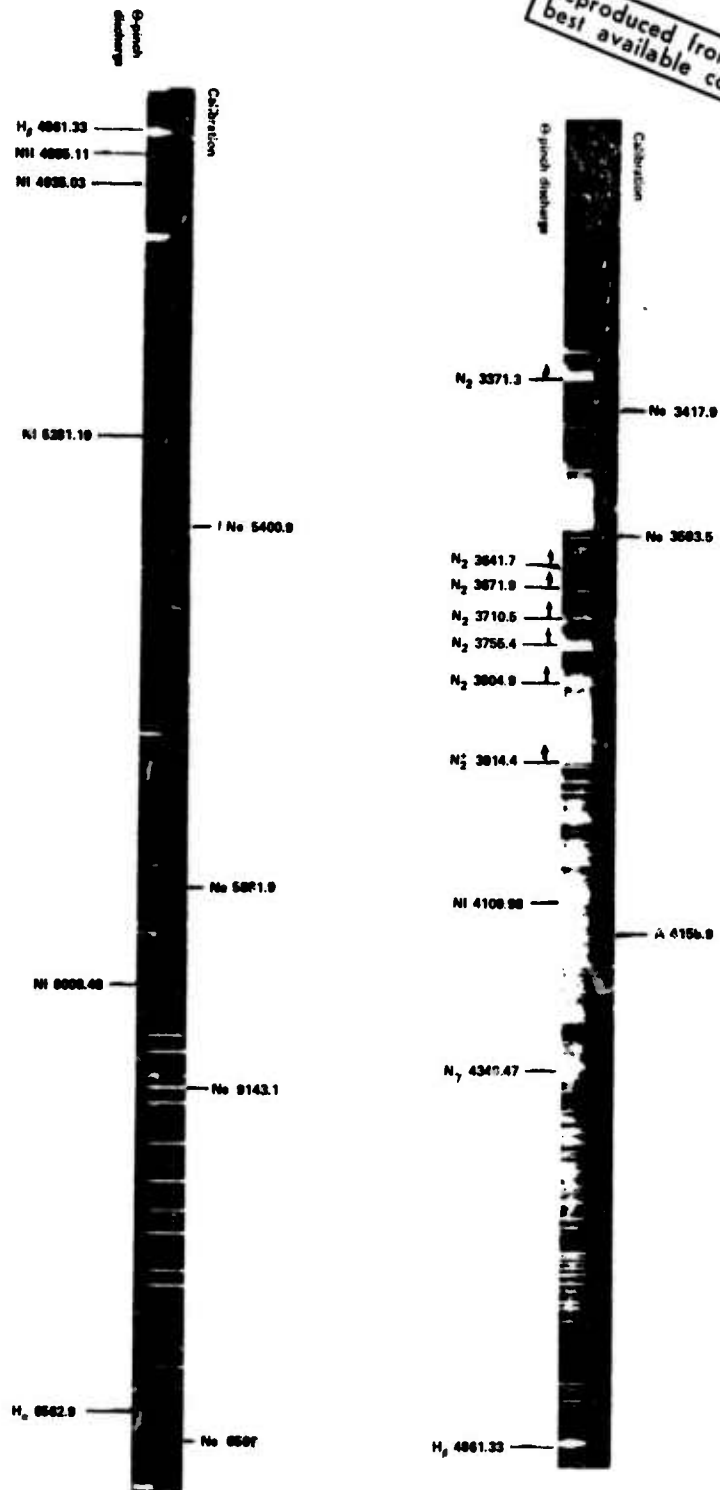

Figure 4. Spectrum of emission by the  $\theta$ -pinch device when filled to a pressure of  $10 \mu$  with gaseous nitrogen.

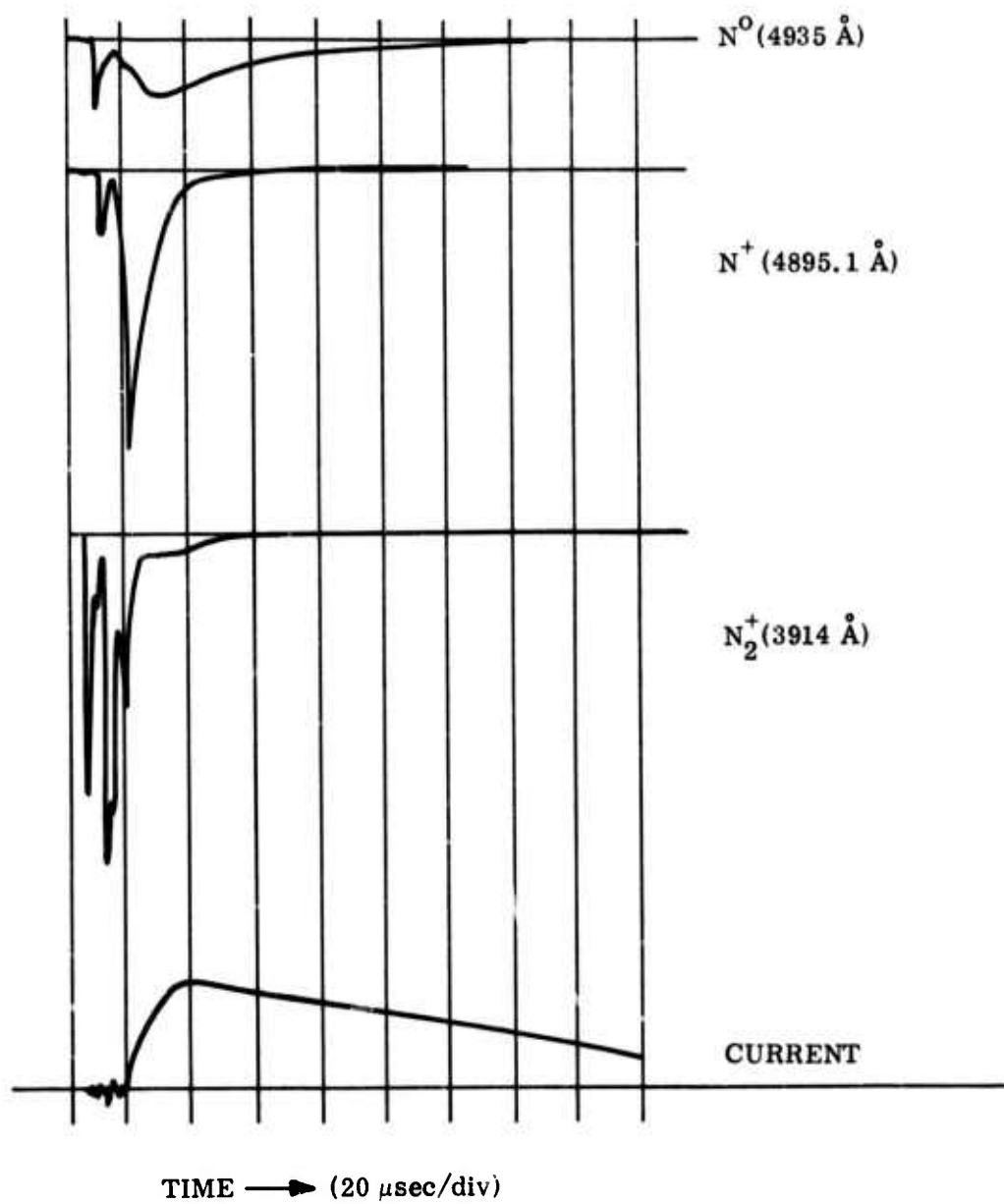

Figure 5. Time resolved emission by the various species present in the pure gaseous nitrogen discharge.

The data were fitted via least squares to a Gaussian. The electron density and temperature obtained in this way are plotted versus time from main bank discharge initiation in Figure 6.

Next, we picked three visible atomic nitrogen lines with known atomic transition probabilities. Using the tungsten lamp shown schematically in Figure 3 as a standard source, we then measured the absolute intensity of these three lines versus time. These lines are 4110 Å, 4935 Å, and 7468 Å and the upper levels from which these lines originate have ionization energies of 0.83, 1.34, and 3.54 eV, respectively. We picked these three upper levels because under our conditions the two with lower ionization energies should be in collisional (Saha) equilibrium with the ground state of the ion.

Assuming the plasma length (L) to be equal to the length of the  $\theta$ -pinch coil (80 cm) one can easily calculate the number densities ( $N_u$ ) of the three upper levels involved using known atomic transition probabilities,

$$N_u = I_{\text{exp}} / \left( \frac{\hbar \omega}{4\pi} A_{1u} L \right) \quad (1)$$

where,  $A_{1u}$  ~ atomic transition probability

L ~ length of plasma

$\omega$  ~ angular frequency of light emitted

$I_{\text{exp}}$  ~ measured absolute line intensity

$N_u$  ~ number density of upper level

The number densities of these three energy levels divided by the level degeneracy (g-factor) are plotted versus level ionization energy for various times after main bank discharge initiation in Figure 7.

Using the electron density and temperature obtained previously from laser scattering Figure 6 and the Saha equation,

$$\frac{N_u}{g_u} = \frac{N_e N_1^+}{2 g_1^+} \left( \frac{mkT}{2\pi\hbar^2} \right)^{-3/2} \exp(-E_u/kT) \quad (2)$$

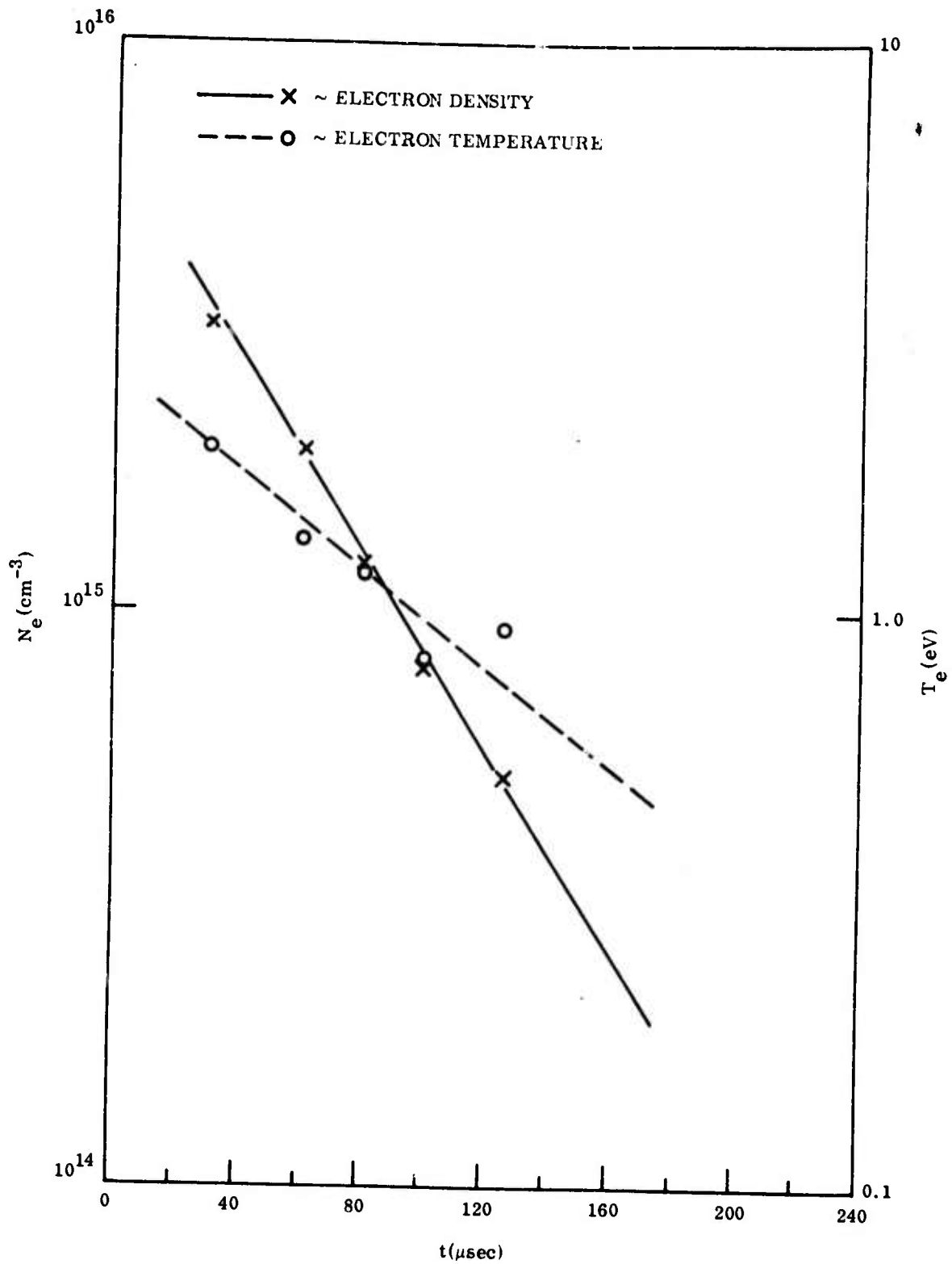

Figure 6. Electron density and electron temperature plotted versus time after initiation of main bank discharge. [This data was obtained from laser scattering at the coil center]

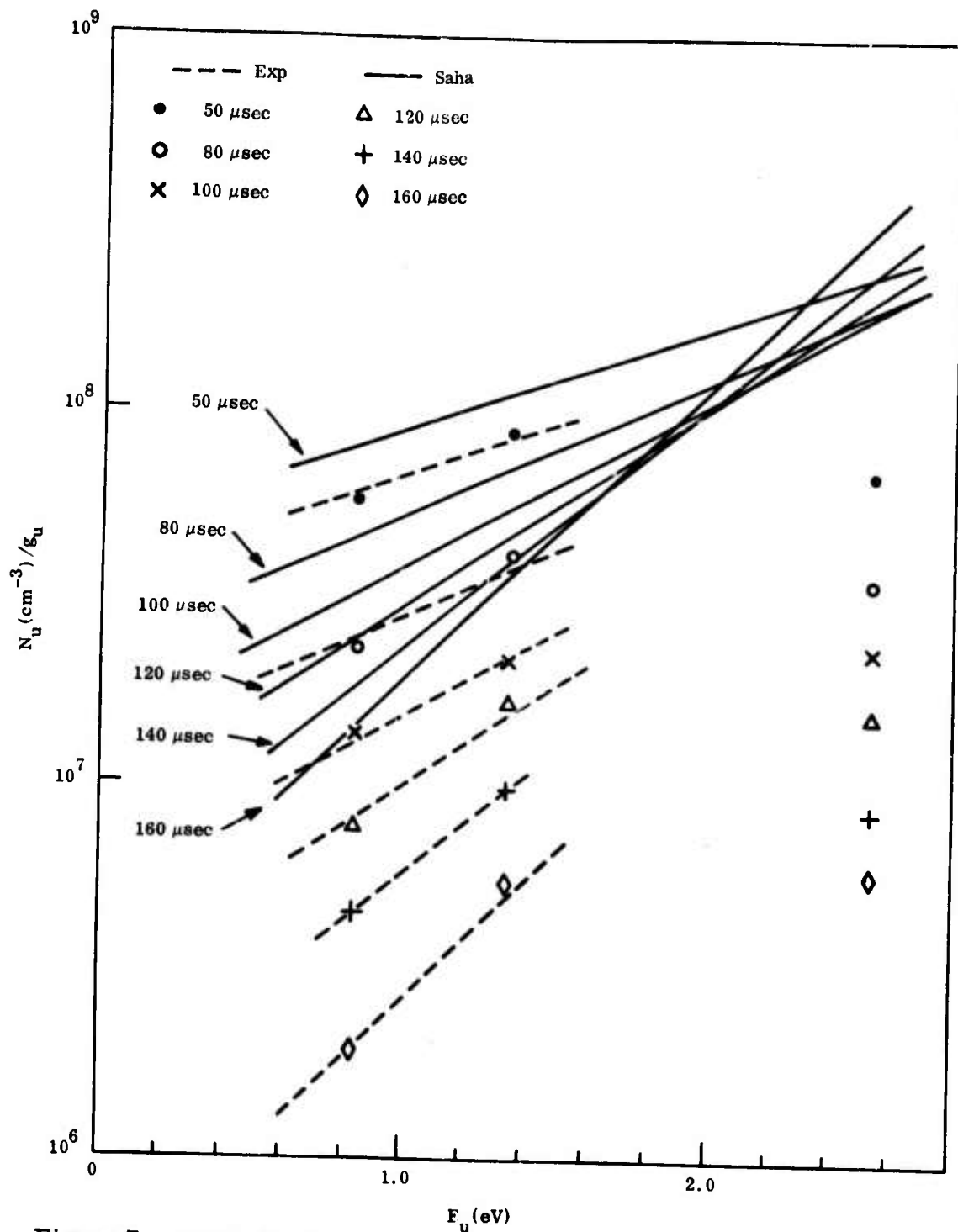

Figure 7. Upper level number density divided by the level degeneracy plotted versus level ionization energy. [Broken line is drawn through experimental points parallel to results calculated from the Saha equation (solid line).]

- where,  $N_u$  ~ upper state number density  
 $g_u$  ~ upper state degeneracy  
 $N_e$  ~ electron density  
 $N_{N_1}^+$  ~ atomic nitrogen ion ground state number density  
 $g_1^+$  ~ atomic nitrogen ion ground state degeneracy  
 $m$  ~ electron mass  
 $k$  ~ Boltzmann's constant  
 $T$  ~ electron temperature  
 $\hbar$  ~ Planck's constant divided by  $2\pi$   
 $E_u$  ~ upper state ionization energy

we can calculate what one would expect if local thermodynamic equilibrium prevailed. To do this we have assumed that the atomic nitrogen ion ground state number density equals the electron density. These results for the relevant times are also shown in Figure 7.

As can be seen, the experimentally obtained number densities do not agree with those calculated from the Saha equation using  $N_e = N_{N_1}^+$ . It should be noted, however, that the slope of the line connecting data from the two states with the lower ionization potential; i. e., those states expected to be in collisional (Saha) equilibrium with the free electron gas, is essentially the same as the slope of the line obtained from Saha's equation. This indicates that the temperature obtained from laser scattering is consistent with the absolute line intensity measurements, since the slope in both cases is proportional to  $1/T$ . It should also be noted that the discrepancy increases with time. One possible reason for this discrepancy is that our assumption  $N_e = N_{N_1}^+$  is incorrect and that in actuality we should have used  $N_e = N_{N_1}^+ + N_{N_2}^+$ , where  $N_{N_2}^+$  is the number density of molecular nitrogen ions, as our statement of quasi-neutrality. Using this statement of quasi-neutrality we have calculated the number density of molecular nitrogen ions necessary to obtain agreement between our experimental results

and those obtained from Saha's equation. This number density along with the number density of atomic nitrogen ions and the electron density is shown graphically in Figure 8.

At present, we are conducting a laser scattering experiment off the end of the  $\theta$ -pinch coil. This is to determine whether or not the use of the coil length as the plasma length in equation (1) is justified. A knowledge of the homogeneity of our plasma will also help us later when we do microwave interferometry to obtain the electron density, since this diagnostic method yields the integral of electron density over the entire plasma length.

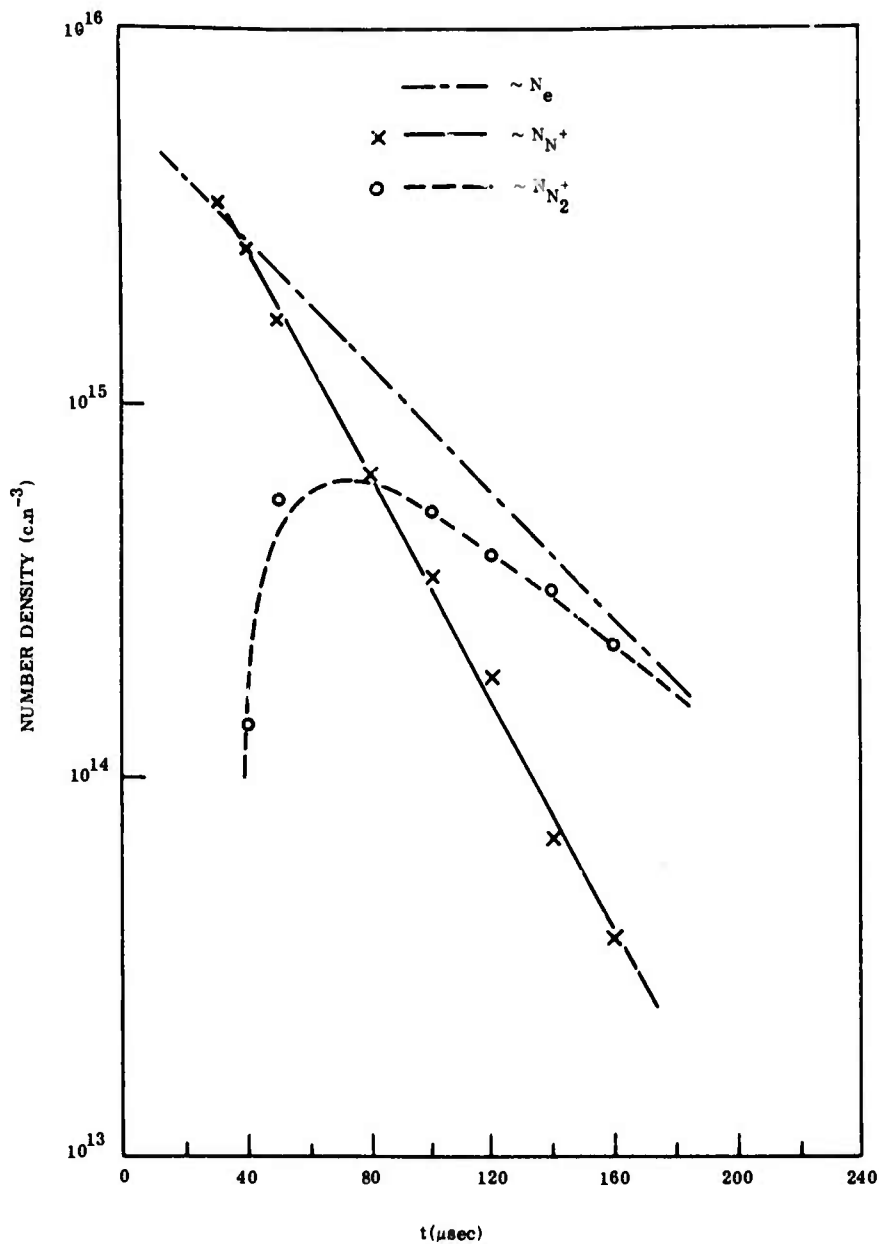

Figure 8. Species number densities of electrons,  $N_e$ , atomic ionized nitrogen,  $N_{N^+}$ , and molecular ionized nitrogen,  $N_{N_2^+}$ , plotted versus time after initiation of main bank discharge.

## SECTION IV

### CONCLUSIONS

Since this project began in mid-January 1973, we have successfully modified our plasma device, the 50 kj  $\theta$ -pinch, to give a slowly decaying nonthermal plasma as well as a measurement of a few level populations in nitrogen. These measurements show a marked discrepancy with what we expected and gives evidence that there may be some means of efficiently producing molecular ions.

## SECTION V

### FUTURE WORK

The following program is proposed for FY 74:

A. 1st Quarter.

1. Complete the study to measure the axial homogeneity of our plasma. This should take only a few more weeks of data taking. As pointed out above, this will be of great help later when a microwave interferometer will be used.
2. Test our explanation for the discrepancy between our experimental number densities and those calculated from the Saha equation. This we can do by placing a flashlamp behind the plasma and looking in absorption for the molecular ion bandhead at 3914.4 Å.

B. 2d Quarter.

We will set up the 8 mm microwave interferometer to determine the electron density at later times,  $N_e \lesssim 10^{13} \text{ cm}^{-3}$ .

C. 3d Quarter.

The electron temperature will be measured at later times by using a Langmuir probe. During this period we also plan on measuring level number densities of atomic nitrogen at later times. This should complete the nitrogen part of the experiment.

D. 4th Quarter.

During this quarter we will begin the oxygen studies by doing laser scattering at early times. We plan on completing the oxygen studies during the first two quarters of FY 75. This will be followed in the second half of the year by measurements in various oxygen-nitrogen gas mixtures. The possibility of quenching collisions and other phenomenon occurring should make this study most interesting as well as informative.