

AD-771 088

THE ELECTROMAGNETIC COMPATIBILITY OF  
AERONAUTICAL COMMUNICATION AND  
NAVIGATION SYSTEMS WITH RADIO  
FREQUENCY DIELECTRIC HEATERS AND  
SUPERREGENERATIVE RECEIVERS

Fred Tabor, et al

IIT Research Institute

Prepared for:

Department of the Air Force  
Federal Aviation Administration

October 1972

DISTRIBUTED BY:

**NTIS**

**National Technical Information Service  
U. S. DEPARTMENT OF COMMERCE  
5285 Port Royal Road, Springfield Va. 22151**

REPORT No. FAA-RD-72-80,II

**THE ELECTROMAGNETIC COMPATIBILITY OF AERONAUTICAL  
COMMUNICATION AND NAVIGATION SYSTEMS WITH RADIO  
FREQUENCY DIELECTRIC HEATERS AND SUPERREGENERATIVE  
RECEIVERS**

AD 771088

Harry Martin & Fred Tabor  
of  
IIT Research Institute  
Under Contract With  
DEPARTMENT OF DEFENSE  
Electromagnetic Compatibility Analysis Center  
Annapolis, Maryland 21402



October 1972

FINAL REPORT

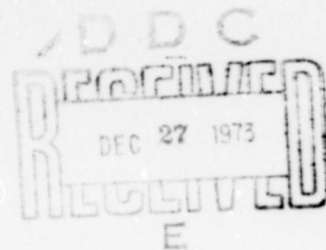

Availability is unlimited. Document may be released to the  
National Technical Information Service, Springfield,  
Virginia 22151, for sale to the public

Prepared for

DEPARTMENT OF TRANSPORTATION

FEDERAL AVIATION ADMINISTRATION  
SYSTEMS RESEARCH & DEVELOPMENT SERVICE  
Washington, D.C. 20591

Reproduced by  
NATIONAL TECHNICAL  
INFORMATION SERVICE  
U S Department of Commerce  
Springfield VA 22151

132

The contents of this report reflect the views of the DOD Electromagnetic Compatibility Analysis Center which is responsible for the facts and the accuracy of the data presented herein. The contents do not necessarily reflect the official views or policy of the Department of Transportation. This report does not constitute a standard, specification or regulation.

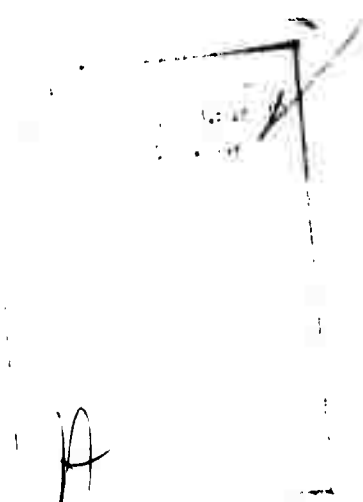

TECHNICAL REPORT STANDARD TITLE PAGE

1. Report No. <b>FAA-RD-72-80,11</b>	2. Government Accession No.	3. Recipient's Catalog No.	
4. Title and Subtitle <b>The Electromagnetic Compatibility of Aeronautical Communication and Navigation Systems with Radio Frequency Dielectric Heaters and Superregenerative Receivers</b>		5. Report Date <b>October 1972</b>	6. Performing Organization Code
		8. Performing Organization Report No. <b>ECAC PR-72-045</b>	
7. Author(s) <b>F. Tabor &amp; H. Martin of IIT Research Institute</b>		10. Work Unit No. <b>Project 213-516-035</b>	
9. Performing Organization Name and Address <b>Department of Defense Electromagnetic Compatibility Analysis Center North Severn Annapolis, Maryland 21402</b>		11. Contract or Grant No. <b>DOT-FA70WAI-175 Task 10</b>	
		13. Type of Report and Period Covered <b>Final Report</b>	
12. Sponsoring Agency Name and Address <b>Department of Transportation Federal Aviation Administration Systems Research and Development Service Washington, D. C. 20591</b>		14. Sponsoring Agency Code	
		15. Supplementary Notes <b>Performed for Frequency Management Division, Spectrum Plans and Programs Branch, FAA.</b>	
16. Abstract <p>Degradation thresholds of interference from radio frequency dielectric heaters and superregenerative receivers to aircraft communication and navigation receivers were established. Degradation thresholds so established were employed to assess the degradation to the aeronautical communication and navigation services under operational conditions. The adequacy of the present regulatory limits governing the radiation from dielectric heaters and superregenerative receivers was examined from the standpoint of prevention of interference to the aeronautical services.</p>			
17. Key Words <b>DIELECTRIC HEATER ELECTROMAGNETIC COMPATIBILITY GARAGE DOOR OPENER ILS/LOC NAVIGATION SUPERREGENERATIVE RECEIVER</b>		18. Distribution Statement <b>VOR Availability is unlimited. Document may be released to the National Technical Information Service, Springfield, Virginia, 22151, for sale to the public.</b>	
19. Security Classif. (of this report) <b>UNCLASSIFIED</b>	20. Security Classif. (of this page) <b>UNCLASSIFIED</b> <i>ia</i>	21. No. of Pages <b>132</b> <b>133</b>	22. Price

**PREFACE**

The Electromagnetic Compatibility Analysis Center (ECAC) is a Department of Defense facility, established to provide advice and assistance on electromagnetic compatibility matters to the Secretary of Defense, the Joint Chiefs of Staff, the military department and other DOD components. The Center, located at North Severn, Annapolis, Maryland 21402, is under executive control of the Director of Defense Research and Engineering and the Chairman, Joints Chiefs of Staff or their designees who jointly provide policy guidance, assign projects, and establish priorities. ECAC functions under the direction of the Secretary of the Air Force and the management and technical direction of the Center are provided by military and civil service personnel. The technical operations function is provided through an Air Force sponsored contract with the IIT Research Institute (IITRI).

This report was prepared for the Systems Research and Development Service of the Federal Aviation Administration in accordance with Interagency Agreement DOT-FA70WAI-175, as part of AF Project 649E under Contract F-19628-73-C-0031, by the staff of the IIT Research Institute at the Department of Defense Electromagnetic Compatibility Analysis Center.

To the extent possible, all abbreviations and symbols used in this report are taken from American Standard Y10.19 (1967) "Units Used in Electrical Science and Electrical Engineering" issued by the United States of America Standards Institute.

Reviewed by:

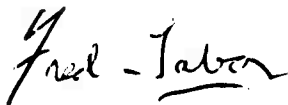

FRED TABOR  
Project Engineer, IITRI



J. M. DETERDING  
Director of Contractor Operations

Approved by:

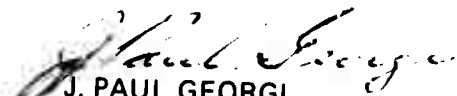

J. PAUL GEORGI  
Technical Director, DOD ECAC



M. A. SKEATH  
Special Projects  
Deputy Director

**TABLE OF CONTENTS**

Subsection	Page
<b>SECTION 1</b>	
<b>INTRODUCTION</b>	
BACKGROUND . . . . .	1- 1
OBJECTIVES . . . . .	1- 1
APPROACH . . . . .	1- 2
<b>SECTION 2</b>	
<b>AIRCRAFT RECEIVERS AND INTERFERENCE SOURCES</b>	
GENERAL . . . . .	2- 1
DESCRIPTION OF INTERFERING SOURCES . . . . .	2- 1
The Dielectric Heater . . . . .	2- 1
The Superregenerative Receiver . . . . .	2- 1
RECEIVER DESCRIPTION . . . . .	2- 2
VHF Communication Receiver . . . . .	2- 2
VHF Omni-Directional Radio Range (VOR) Receiver . . . . .	2- 2
Instrument Landing System Localizer (ILS-LOC) Receiver . . . . .	2- 2
<b>SECTION 3</b>	
<b>DEVELOPMENT OF DEGRADATION CRITERIA</b>	
INTERFERING SOURCE MODELS . . . . .	3- 1
Dielectric Heater . . . . .	3- 1
Superregenerative Receiver . . . . .	3- 1
COMMUNICATION RECEIVER DEGRADATION . . . . .	3- 5
Receiver Model . . . . .	3- 5
Desired Signal . . . . .	3- 5
Dielectric Heater Interference . . . . .	3- 5
Superregenerative Receiver Interference . . . . .	3- 8
Summary of Communication Receiver Degradation . . . . .	3- 8

**TABLE OF CONTENTS (Continued)**

**SECTION 3 (Continued)**

Subsection	Page
<b>ILS LOCALIZER NAVIGATION RECEIVER DEGRADATION</b> . . . . .	<b>3-13</b>
Receiver Model . . . . .	3-13
Desired Signal . . . . .	3-15
Measurement Observations . . . . .	3-15
Dielectric Heater Interference . . . . .	3-18
Superregenerative Receiver Interference . . . . .	3-18
Summary of ILS/LOC Receiver Degradation . . . . .	3-21
<b>VOR NAVIGATION RECEIVER DEGRADATION</b> . . . . .	<b>3-22</b>
Receiver Model . . . . .	3-22
Desired Signal . . . . .	3-22
Dielectric Heater Interference . . . . .	3-24
Superregenerative Receiver Interference . . . . .	3-26
Summary of VOR Navigation Receiver Degradation . . . . .	3-26
<b>SUMMARY OF COMMUNICATION AND NAVIGATION RECEIVER DEGRADATION</b> . . . . .	<b>3-29</b>

**SECTION 4**

**APPLICATION OF DEGRADATION CRITERIA TO VHF COMMUNICATION AND NAVIGATION SERVICES**

<b>DEGRADATION TO COMMUNICATION SERVICES</b> . . . . .	<b>4- 1</b>
Dielectric Heater Interference to Airborne Receivers . . . . .	4- 1
Dielectric Heater Interference to Ground Receivers . . . . .	4- 6
Superregenerative Receiver Interference to Airborne Receivers . . . . .	4- 8
Superregenerative Receiver Interference to Ground Receivers . . . . .	4-10
<b>DEGRADATION TO ILS LOCALIZER NAVIGATION SERVICES</b> . . . . .	<b>4-11</b>
,Dielectric Heater Interference to Airborne Receivers . . . . .	4-11
Superregenerative Receiver Interference to Airborne Receivers . . . . .	4-15
<b>DEGRADATION TO VOR NAVIGATION SERVICES</b> . . . . .	<b>4-15</b>
Dielectric Heater Interference to Airborne Receivers . . . . .	4-15
Superregenerative Receiver Interference to Airborne Receivers . . . . .	4-19
,Summary of Radiation Limits to Prevent Interference . . . . .	4-21

**TABLE OF CONTENTS (Continued)**

Subsection	Page
<b>SECTION 5</b>	
<b>CONCLUSIONS</b>	
	5- 1

**LIST OF ILLUSTRATIONS**

Figure		
2- 1	Indicator Meter . . . . .	2- 3
3- 1A	Time Waveform of a Single-Phase, Full-Wave Dielectric Heater Signal . . . . .	3- 2
3- 1B	Spectrum of Single Phase, Full-Wave Dielectric Heater Signal . . . . .	3- 2
3- 2A	Time Waveform of a Three-Phase, Half-Wave Dielectric Heater Signal . . . . .	3- 3
3- 2B	Spectrum of Three-Phase, Half-Wave Dielectric Heater Signal . . . . .	3- 3
3- 3A	Time Waveform of Three-Phase, Full-Wave Dielectric Heater Signal . . . . .	3- 4
3- 3B	Spectrum of Three-Phase, Full-Wave Dielectric Heater Signal . . . . .	3- 4
3- 4	Communication Receiver Model Diagram . . . . .	3- 6
3- 5	Communication Receiver Output Signal-to-Noise Plus Interference Ratio vs. $\Delta f$ for Dielectric Heater Interfering Signals . . . . .	3- 7
3- 6	Degradation to a Communication Receiver from a Dielectric Heater with a Low Sweep Rate . . . . .	3- 9
3- 7	Analytical Degradation to a Communication Receiver from a Dielectric Heater with a High Sweep Rate . . . . .	3-10
3- 8	Analytical Degradation to Communication Receivers due to Superregenerative Receiver Radiation . . . . .	3-11
3- 9	The Effect of Radiations from Superregenerative Receivers on Articulation Index in Communications Receivers . . . . .	3-12
3-10	Block Diagram of the Audio Stages of the ILS Localizer Navigation Receiver . . . . .	3-14
3-11	Simulated ILS Localizer Receiver Diagram . . . . .	3-16
3-12	Localizer Navigation Receiver Audio Stage Model . . . . .	3-17
3-13	Analytical Localizer Navigation Receiver Degradation due to Dielectric Heater . . . . .	3-19

**TABLE OF CONTENTS (Continued)**

**LIST OF ILLUSTRATIONS (Continued)**

Figure	Page
3-14 Analytical Degradation to ILS/Localizer Receivers due to Superregenerative Receiver Radiations . . . . .	3-20
3-15 VOR Navigation Receiver Audio Stages . . . . .	3-23
3-16 Simulated VOR Receiver Diagram . . . . .	3-25
3-17 Analytical Degradation to a VOR Navigation Receiver from Dielectric Heater Emissions . . . . .	3-27
3-18 Analytical Degradation to a VOR Navigation Receiver from Superregenerative Receiver Radiations . . . . .	3-28
4- 1 Basic Transmission Loss . . . . .	4- 2
4- 2 Communication Receiver Input Signal-to-Interference Ratio at Various Aircraft Locations for a Dielectric Heater Radiation of 10 $\mu$ V/meter at 5280 feet . . . . .	4- 4
4- 3 Communication Receiver Input Signal-to-Interference Ratio at Various Aircraft Locations for a Dielectric Heater Radiation of 10 $\mu$ V/meter at 5280 feet . . . . .	4- 7
4- 4 Communication Receiver Input Signal-to-Interference Ratio at Various Aircraft Locations for a Family of Interfering Path Distances with a Dielectric Heater Radiating 10 $\mu$ V/m at 5280 feet . . . . .	4- 9
4- 5 Communication Receiver Input Signal-to-Interference Ratios at Various Aircraft Locations for a Family of Interfering Path Distances with a Superregenerative Receiver Interferer Radiating 50 $\mu$ V/meter . . . . .	4-12
4- 6 ILS Localizer Receiver Input Signal-to-Interference Ratios at Various Aircraft Locations for a Dielectric Heater Radiation of 10 $\mu$ V/meter at 5280 feet . . . . .	4-14
4- 7 ILS Localizer Receiver Input Signal-to-Interference Ratio at Various Aircraft Locations for a Dielectric Heater Radiation of 10 $\mu$ V/meter at 5280 feet . . . . .	4-16
4- 8 VOR Receiver Input Signal-to-Interference Ratio at Various Aircraft Locations for a Dielectric Heater Radiation of 10 $\mu$ V/meter at 5280 feet . . . . .	4-18

**TABLE OF CONTENTS (Continued)**

**LIST OF ILLUSTRATIONS (Continued)**

<b>Figure</b>		<b>Page</b>
4- 9	VOR Receiver Signal-to-Interference Ratio at Various Aircraft Locations for a Dielectric Heater Radiation of 10 $\mu$ V/meter at 5280 feet . . . . .	4-20

**LIST OF TABLES**

<b>Table</b>		
3-1	INPUT S/I (dB) FOR COMMUNICATION RECEIVERS FOR VARIOUS ARTICULATION INDICES . . . . .	3-13
3-2	INPUT S/I RATIOS FOR DOT AND FLAG RESPONSES FOR INPUT S/N RATIO = 66 dB . . . . .	3-21
3-3	INPUT S/I (IN dB) FOR TWO INDICATOR RESPONSES FOR INPUT S/N RATIO = 66 dB . . . . .	3-29
3-4	INPUT (S/I) IN dB REQUIRED TO DEGRADE COMMUNICATION AND NAVIGATION RECEIVERS FOR VARIOUS INTERFERERS . . .	3-30
4-1	REQUIRED INTERFERER RADIATION LIMITS . . . . .	4-22
5-1	DIELECTRIC HEATER INTERFERENCE . . . . .	5- 2

**LIST OF APPENDICES**

**Appendix**

- A THE RECEIVER WAVEFORM SIMULATION (RWS) MODEL
- B MEASUREMENTS
- C DERIVATION OF EQUATIONS
- D RECEIVER SELECTIVITIES

**REFERENCES**

## SECTION 1

### INTRODUCTION

#### BACKGROUND

The Federal Aviation Administration (FAA) has reported instances of harmful interference to the aeronautical communication and navigation services from two classes of generally unlicensed radio frequency emitters (Reference 1). The first class comprises those Industrial, Scientific and Medical (ISM) devices which employ radio frequency energy to perform their function. Arc welders, dielectric heaters and medical diathermy machines belong to this class. The second class is composed of those emitters whose radio frequency emissions are a by-product of their operation. Automobile ignition systems, television receivers and superregenerative receivers are included in the second class.

The Electromagnetic Compatibility Analysis Center (ECAC) was tasked by the FAA (Reference 2) to determine the nature and severity of interference to communication and navigation services from ISM and incidental radiation devices. The overall project consists of a measurement program to determine the emission spectra of such devices, the development of specific procedures for use by FAA and other agencies to measure the spectra of superregenerative receivers and dielectric heaters, and the assessment of the degradation effects of only the latter devices on communications and navigation equipment.

The material herein assesses the degradation of Aeronautical Communication and Navigation Services as a result of radiation from dielectric heaters and superregenerative receivers. The measurements and measurement procedures were reported in Reference 3.

#### OBJECTIVES

The objectives of this task were to:

1. Determine the susceptibility of the Aeronautical Communication and Navigation Services to interference from the radiation of dielectric heaters and superregenerative receivers.

2. Develop criteria for the prevention of interference to the aeronautical services from the radiation of dielectric heaters and superregenerative receivers.

## APPROACH

Degradation in performance to VHF communication and navigation receiving equipment due to interference from dielectric heaters and superregenerative receivers was determined in two ways.

In the measurement portion of the project, desired and undesired signals were injected into the "victim" receivers concerned and degradation thresholds were established. Signal generators were employed to simulate the desired communication or navigation signals and the undesired dielectric heater or superregenerative receiver interference. APPENDIX B reports on these measurements.

As a parallel effort, receiver degradation thresholds were established mathematically. A computerized Receiver Waveform Simulation (RWS) model (Reference 4 and APPENDIX A) was employed to determine degradation under the same conditions of desired-to-undesired power ratios that were examined in the measurement program. Since the two methods of determining degradation produced results that agreed closely, the RWS model was then employed to extend the analysis to cases not covered by measurements. Degradation thresholds so established were then employed in operational situations to determine degradation to communication and navigation services.

The existing regulatory criteria specifying the upper limits of radiation from dielectric heaters and superregenerative receivers were employed to define the maximum allowable radiation levels of the potential interfering sources. Two aircraft operational deployments (Flight Profiles) were assumed in order to establish the distance separation between the aircraft and the desired signal source and between the aircraft and the interfering signal source. Signal-to-Interference (S/I) power ratios were thus established for all points along the flight profiles. The previously determined (S/I) ratio criteria for degradation was then applied, and the degree of degradation along the flight path was determined. Lastly, modifications to regulatory criteria were developed that would be effective in controlling interference from dielectric heaters and superregenerative receivers.

## SECTION 2

### AIRCRAFT RECEIVERS AND INTERFERENCE SOURCES

#### GENERAL

The degradation in performance of aircraft VHF communication and navigation receivers was determined for interference from dielectric heaters and superregenerative receivers. The degradation analysis is reported in Sections 3 and 4. This section describes in general terms the two interfering sources, and the three receivers for which degradation in performance was determined.

#### DESCRIPTION OF INTERFERING SOURCES

##### The Dielectric Heater

The dielectric heater is an industrial machine employing radio frequency energy to heat plastics or other dielectric material. The heater applies a high frequency potential, approximating 10,000 volts, across the dielectric material to be heated. Dielectric heaters produce output powers from 1,000 to 100,000 watts in the frequency range of 5.1 MHz to 100 MHz. The sound of the interference from these heaters is a raspy hum with possibly a transitory beat note between the heater carrier and a desired signal carrier caused by the frequency drift characteristics of the heater. Reference 3 describes the electrical characteristics of dielectric heaters in detail.

##### The Superregenerative Receiver

The superregenerative receiver is unlike the conventional superheterodyne receiver in that no intermediate amplifier (IF) stages are employed. Instead, the functions of amplification and detection are performed by an oscillating detector. The popularity of this receiver derives from the fact that it is much simpler in design and costs less to manufacture than does the superheterodyne design. As a consequence such receivers are found in inexpensive versions of "handi talkies", garage door openers and converters in the police and aircraft band. The disadvantage of the superregenerative receiver is that the oscillating detector acts as a transmitter and radiates through the receiver antenna. In the absence of an incoming signal the radiation from this receiver is a broad-band, random noise-modulated signal. In the presence of an incoming signal, a combination of CW signals are superimposed in the noise output from the detector. The CW signals are separated in frequency by the "quench" frequency as described in Reference 3.

## RECEIVER DESCRIPTION

### VHF Communication Receiver

Aircraft VHF communication receivers are crystal-controlled for the reception of amplitude modulated voice signals in the 118-136 MHz band of frequencies. They employ 50 kHz channeling capability and generally have intermediate amplifier (IF) bandwidths of 40 kHz. Squelch is employed to mute the audio output in the absence of an incoming signal. They are employed for communications with FAA controllers in air terminal areas and with en route controllers. The air lines use them in addition, for communications concerning company business.

### VHF Omni-Directional Radio Range (VOR) Receiver

The VOR system shares the VHF band between 108 and 112 MHz, occupying alternate (even) 100 kHz channels with the ILS-LOC system, and uses the 112-118 MHz band exclusively at 100 kHz intervals. The VOR receiver and its associated indicator furnishes to the pilot azimuth information of a VOR transmitter station at a specific ground location. The VOR ground station transmits two 30 Hz modulation tones whose phase with respect to one another is a function of angular separation from magnetic north. The airborne receiver performs the phase comparison of the 30 Hz signals, and thus determines the azimuth of the ground station with respect to the aircraft. A left-right indicator in the aircraft's dash panel shows the deviation from a pre-set flight path towards or from the ground station.

### Instrument Landing System Localizer (ILS-LOC) Receiver

The ILS-LOC receiver and its indicator provide lateral guidance information to the pilot. This receiver shares the VHF band from 108-112 MHz on odd 100 kHz channels with the VOR. The ground ILS-LOC station transmits, by directional arrays, tones of 150 Hz and 90 Hz. The aircraft ILS-LOC receiver demodulates these tone signals and uses them to actuate a left-right indicator on the pilot's dash panel. If the aircraft were flying to the right of the center line of the landing runway, the 150 Hz tone would predominate; conversely if the aircraft were to the left, the 90 Hz tone would be dominant. If the aircraft were exactly on course, equal amounts of 90 and 150 Hz tones would be received, and the left-right indicator would be centered.

In many cases the functions of VOR and ILS-LOC are combined into one receiver and indicator; such a system is called a VOR/LOC receiver. Figure 2-1 is a

representation of the pilot's left-right indicator. Note that the scale is calibrated in "dots" rather than degrees. Since the pilot's task is to fly the aircraft such that the needle is always centered, absolute calibration in degrees is not required. The "To-From" indicator, together with the bearing selector, gives an indication of whether the aircraft is flying toward or away from a VOR station. The "flag" will appear in the window when the signal is too weak, will peep intermittently at marginal signal-plus-noise levels, and disappear altogether when a usable signal is imposed.

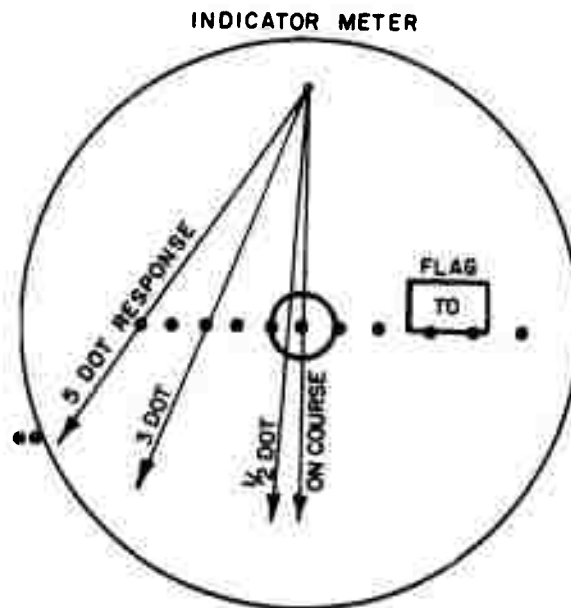

Figure 2-1. Indicator Meter

## SECTION 3

### DEVELOPMENT OF DEGRADATION CRITERIA

The Receiver Waveform Simulation (RWS) model (Reference 4) was used to predict signal-to-noise-plus-interference ratios at the outputs of VHF communication and navigation receivers. Additionally the model predicts the Articulation Index (AI), a measure of voice intelligibility as described in Reference 5, at the output of the communication receivers.

The RWS is a computerized model that accepts a desired and an interfering signal at its input. It processes these signals through a selectable number of intermediate frequency stages, an envelope detector, and a selectable number of audio frequency stages. It then calculates an output signal-to-noise-plus-interference ratio. A description of the model is contained in APPENDIX A.

#### INTERFERING SOURCE MODELS

Four interfering signals were used. Three were simulated dielectric heater waveforms, and one was a simulated superregenerative receiver waveform.

##### Dielectric Heater

The three dielectric heater waveforms simulated were carrier frequencies modulated by 1) single phase, full wave, 2) three phase, half wave and 3) three phase, full wave rectified signals. The time waveforms and emission spectra of these signals are shown in Figures 3-1, 3-2 and 3-3.

To simulate the carrier frequency variation of the dielectric generator, the RWS model was programmed for frequency differences ( $\Delta f$ ) between the desired and interfering frequencies of 0, 100, 500, 1,000, 2,000, 6,000, 10,000 and 20,000 Hz.

##### Superregenerative Receiver

A broadband random noise signal was used to simulate the superregenerative receiver waveform. Random noise is generated in the RWS model by using 8192 equal amplitude sine waves spaced 20 Hz apart. The phase of each sine wave is selected from a random number table.

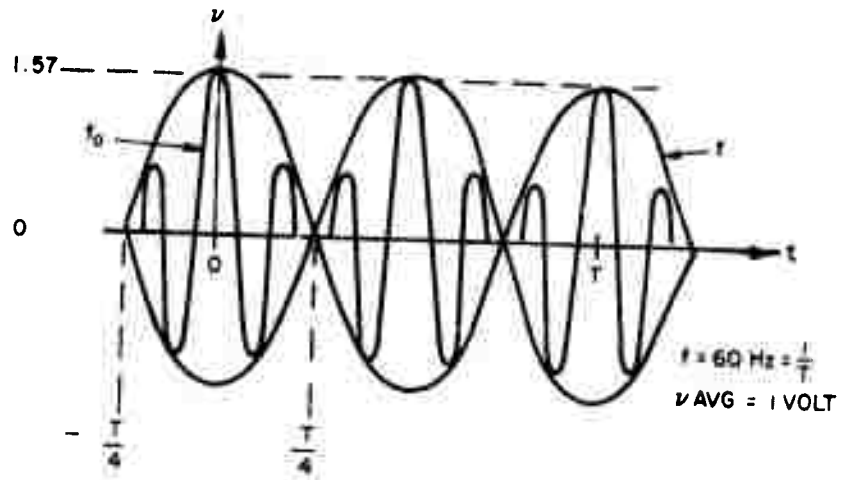

$$v = [1.57 \cos(377t) - 1] \cos 2\pi f_0 t + \cos 2\pi f_0 t, \text{ FOR } -\frac{T}{4} \leq t \leq \frac{T}{4}$$

Figure 3-1A. Time Waveform of a Single-Phase, Full-Wave Dielectric Heater Signal

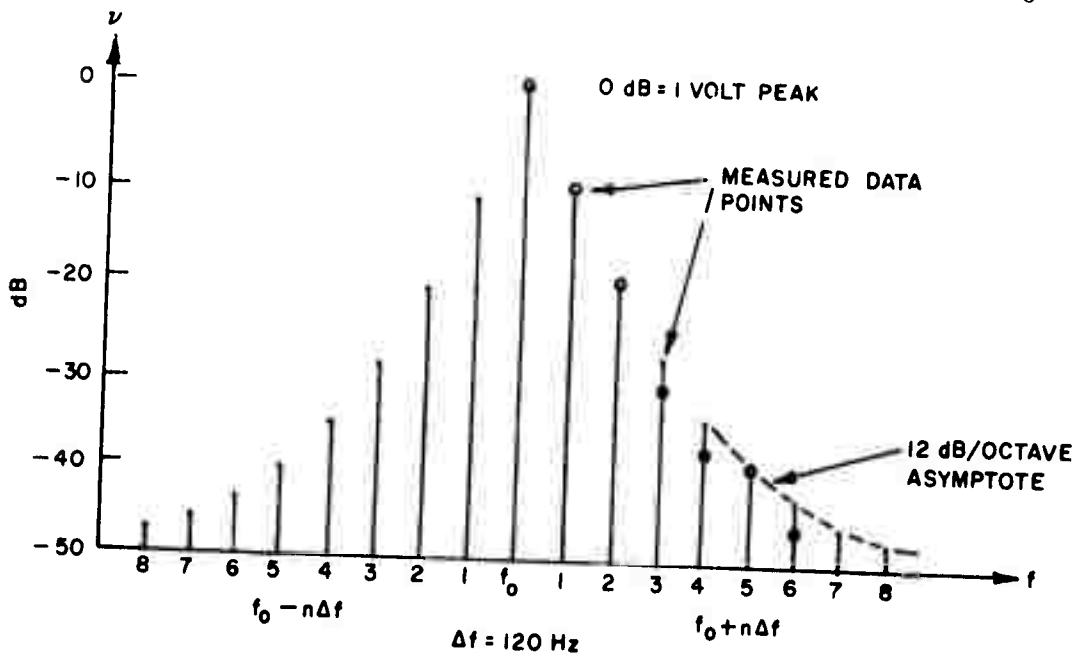

Figure 3-1B. Spectrum of Single-Phase, Full-Wave Dielectric Heater Signal

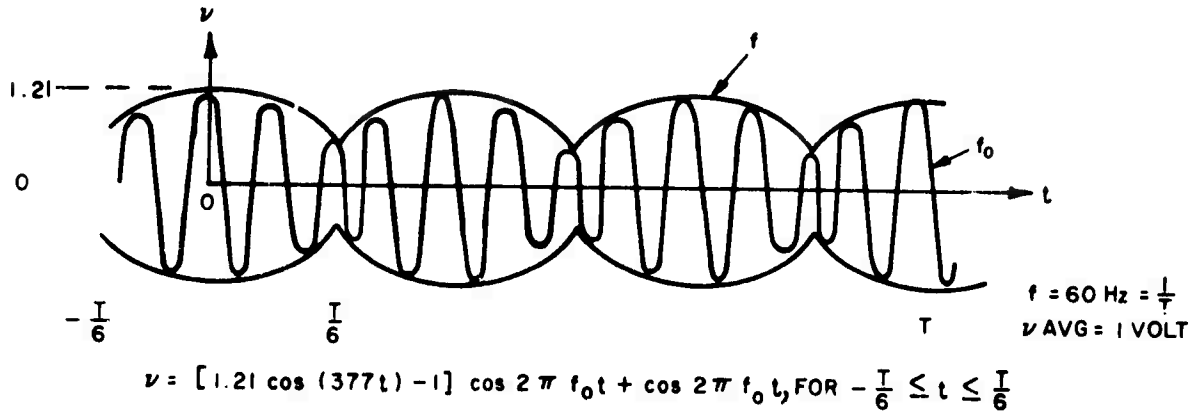

Figure 3-2A. Time Waveform of a Three-Phase, Half-Wave Dielectric Heater Signal

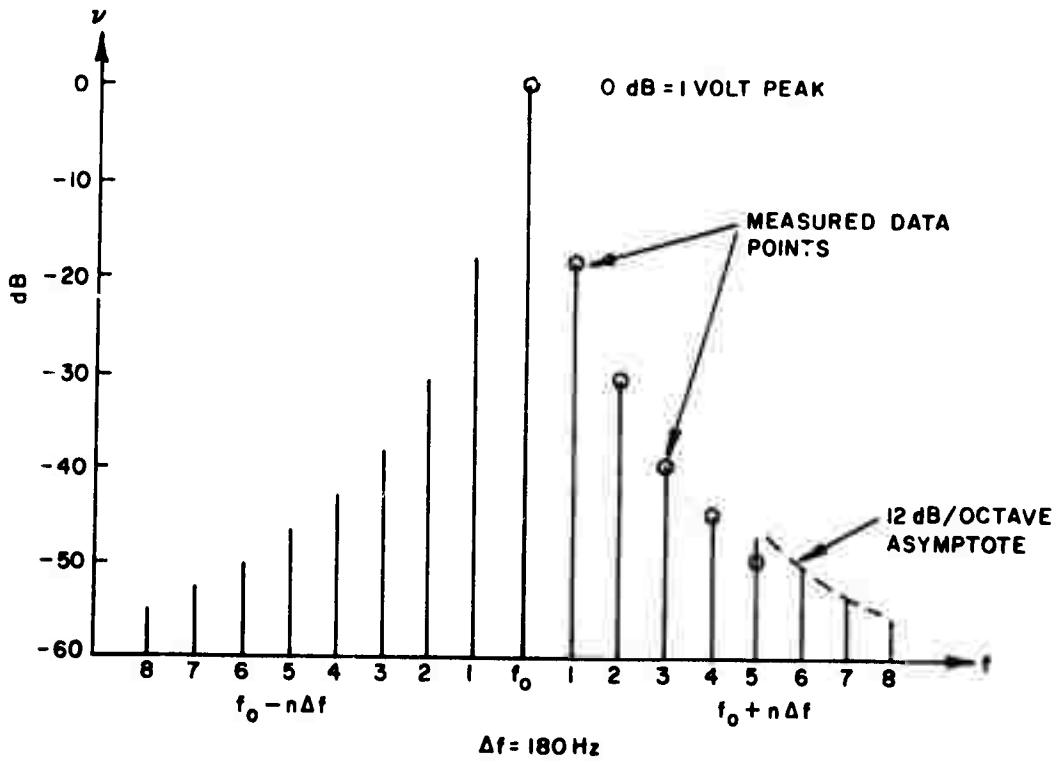

Figure 3-2B. Spectrum of Three-Phase, Half-Wave Dielectric Heater Signal

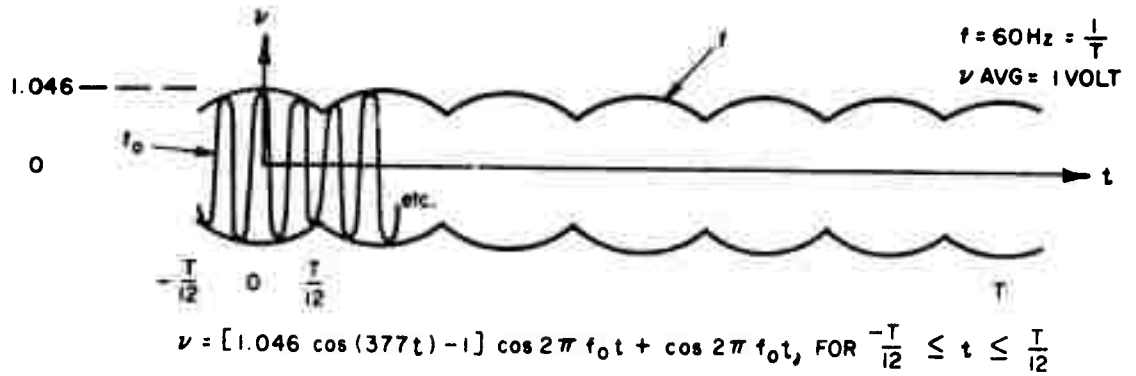

Figure 3-3A. Time Waveform of Three-Phase, Full-Wave Dielectric Heater Signal

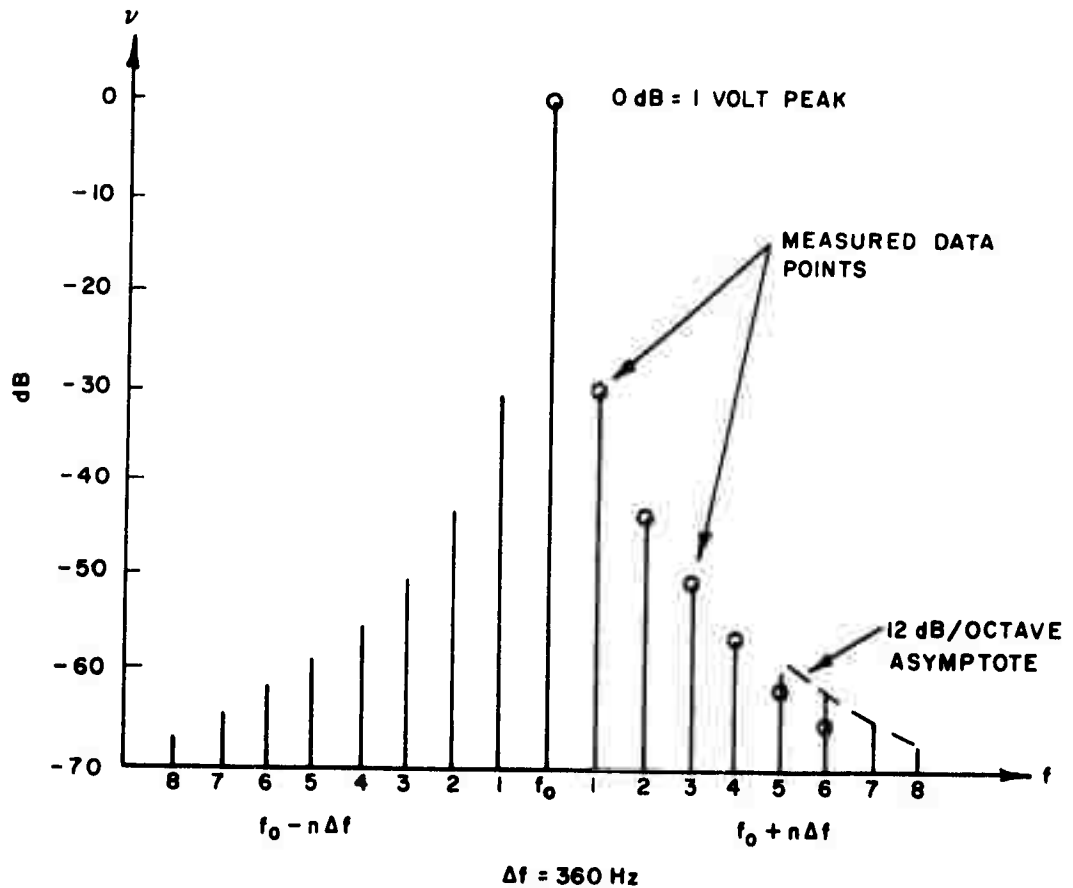

Figure 3-3B. Spectrum of Three-Phase, Full-Wave Dielectric Heater Signal

## COMMUNICATION RECEIVER DEGRADATION

### Receiver Model

The communication receiver that was synthesized in the RWS model for this analysis consisted of three double-tuned intermediate frequency stages with a 3 dB bandwidth of 40 kHz. The audio circuitry model was synthesized by a four-stage low pass filter and a two-stage high pass filter with upper and lower 3 dB points of 2 kHz and 100 Hz respectively. A block diagram of a communication receiver is shown in Figure 3-4. This figure shows where the ratios of the desired signal power (S), the interfering power (I), and the noise power (N) are referenced.

### Desired Signal

A carrier frequency ( $f_o$ ) located in the center of the 40 kHz IF passband of the communication receiver was modulated 30% with a 400 Hz tone. The frequency spectrum of this time waveform (a pair of symmetrically located sidebands, 16.5 dB less than the carrier) was used as the desired signal input to the RWS.

### Dielectric Heater Interference

Desired signal levels of 5  $\mu$ V and 1,000  $\mu$ V were chosen as representative of weak and strong signal situations; these levels correspond to input Signal-to-Noise ratios (S/N) of 20 dB and 66 dB respectively.

*Interference Mechanisms.* Interference from the dielectric heater to the communication receiver is caused by either the beat frequency of the desired and interfering carriers, or the dielectric carrier's sideband intermodulation, or both. When the input S/I ratio is greater than approximately -10 dB, and the interfering  $\Delta f$  is within the audio passband, interference is caused by the beat note. When the interfering  $\Delta f$  is outside the audio passband, but within the IF passband, interference is caused by intermodulation products between the desired and interfering sidebands. When the input S/I ratio is less than approximately -30 dB, interference is due to the modulation sidebands.

Figure 3-5 shows the audio output signal-to-noise-plus-interference ratio of a communication receiver as a function of  $\Delta f$ . As the interfering frequency sweeps through the IF and audio passband, the output S/(N + I) ratio changes from a lower

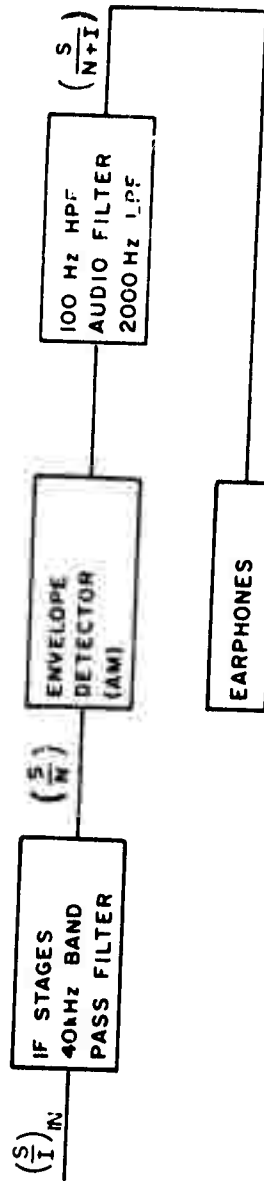

Figure 3-4. Communication Receiver Model Diagram

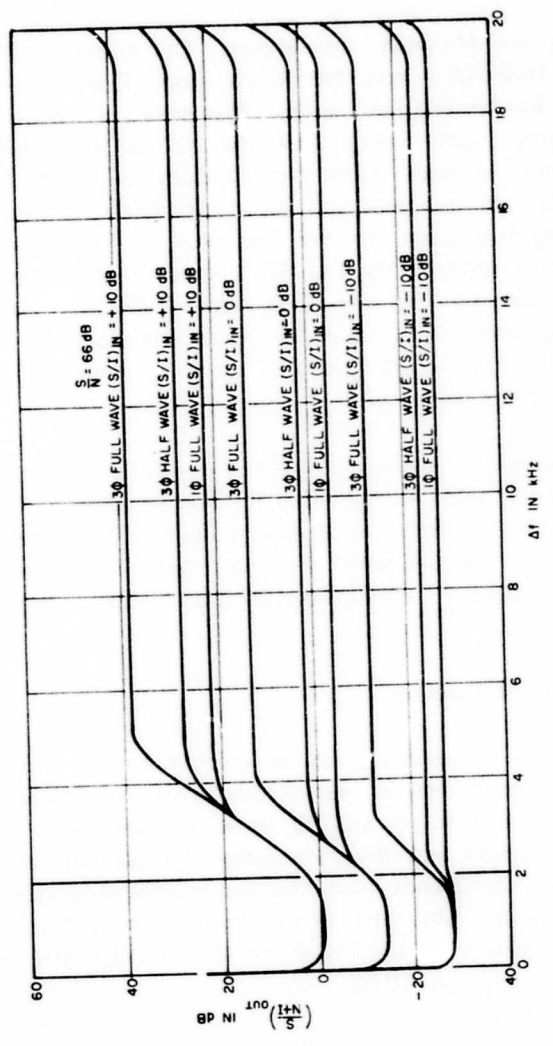

Figure 3-5. Communication Receiver Output Signal-to-Noise Plus-Interference Ratio vs.  $\Delta f$  for Dielectric Heater Interfering Signals

level (at  $\Delta f < 2$  kHz) to a higher level (at  $\Delta f > 4$  kHz). The higher level is caused by intermodulation products between the desired and interfering signals (but not the beat note), and the lower level is caused by the beat note of the desired and interfering carriers.

*Cases of Maximum and Minimum Interference.* The output S/(N+I) ratio and the voice Articulation Index (AI) may be found from Figures A-4 through A-15 (APPENDIX A) when the interfering carrier frequency is constant. When the interfering carrier frequency varies with time, the AI becomes difficult to assess because, as the interfering frequency sweep rate increases (or spends less time in the IF passband), the interference decreases and the AI increases. The problem is better understood by examining two cases. In the first case, the interfering frequency is sweeping slowly enough to approximate the RWS model's constant carrier frequency mode; for this case the minimum AI occurs at a  $\Delta f = 1,000$  Hz. In the second case, the interfering frequency varies fast enough to prevent the beat note from causing significant degradation. For this second case the detected modulation sidebands and intermodulation products cause degradation.

The maximum interfering situation is when the interfering carrier is sweeping slowly (the first case above), and the minimum interfering situation (the second case above) is when the interfering carrier is sweeping rapidly. These results have been extracted from Figures A-4 through A-15 and are shown in Figures 3-6 and 3-7. Measured data from Figure B-7 (APPENDIX B) are plotted on Figure 3-6 for comparison with the RWS results.

#### **Superregenerative Receiver Interference**

The synthesis of the degradation to a communication receiver from the radiation of a superregenerative receiver was accomplished by employing the random noise discussed previously. Figures 3-8 and 3-9 show the calculated receiver output Signal-to-Noise ratio (S/N) values and the Articulation Indices (AI), as a function of the input S/I ratio. Since interference from the superregenerative receiver is random noise in character, the output S/N ratio is directly proportional to the input S/N ratio. This effect can be seen in Figure 3-8 where, for an input S/N ratio change of 10 dB, the output S/N ratio changes 10 dB.

#### **Summary of Communication Receiver Degradation**

TABLE 3-1 summarizes the input Signal-to-Interference (S/I) ratios required to

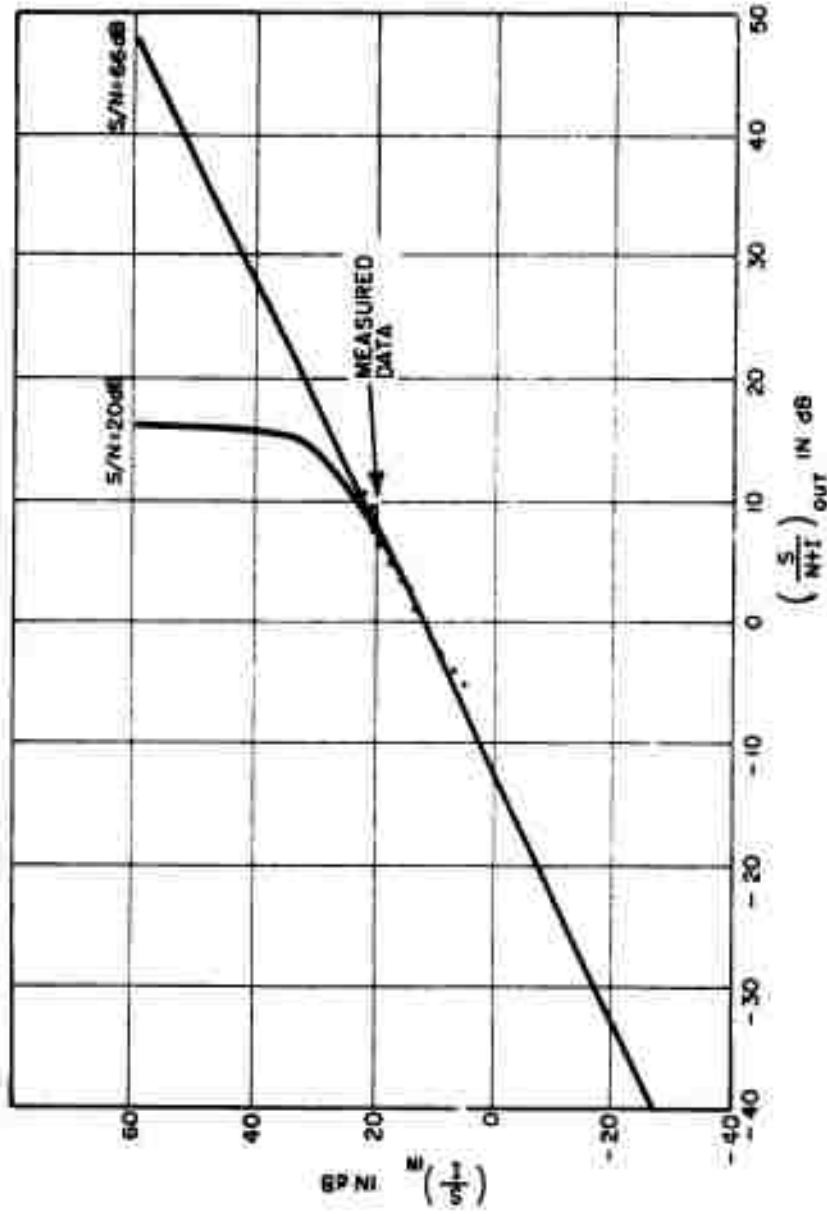

Figure 3-6. Degradation to a Communication Receiver from a Dielectric Heater with a Low Sweep Rate (maximum interfering case, single phase and three phase)

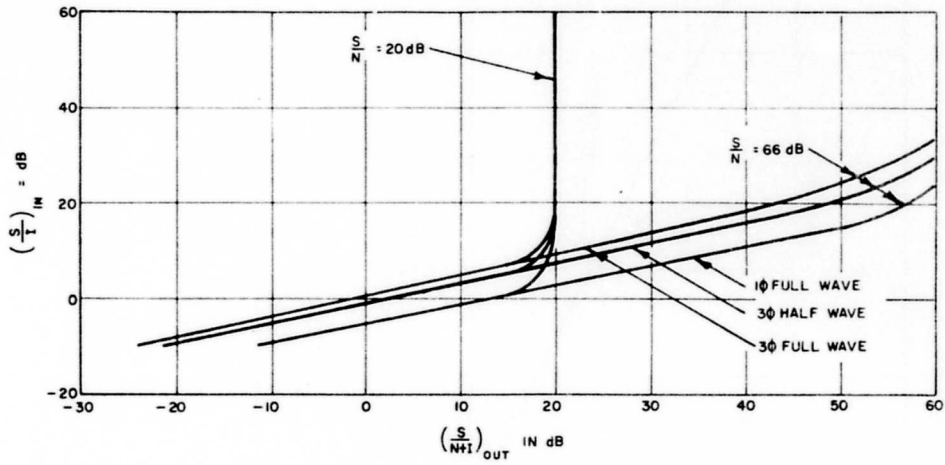

Figure 3-7. Analytical Degradation to a Communication Receiver from a Dielectric Heater with a High Sweep Rate (minimum interfering case)

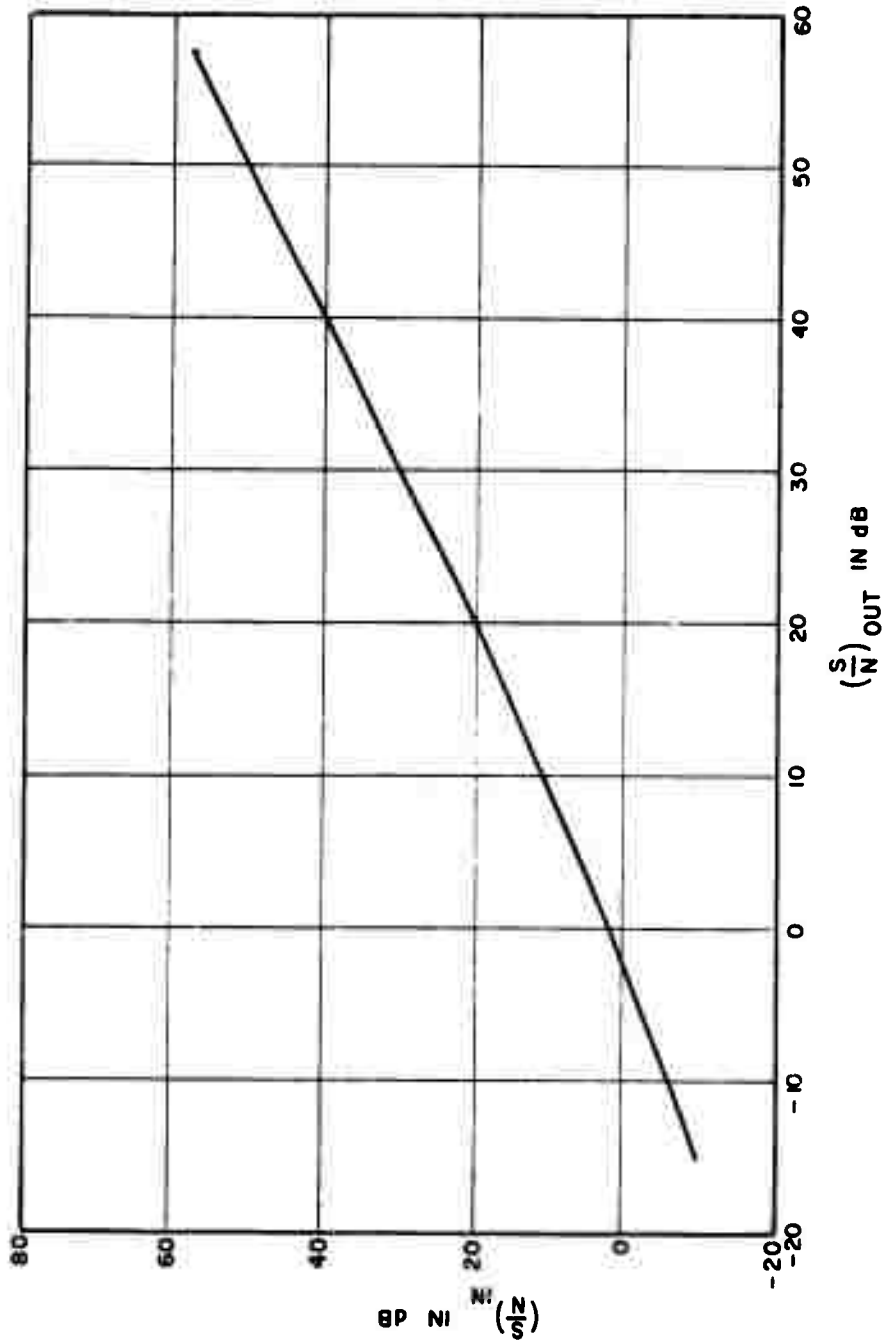

Figure 3-8. Analytical Degradation to Communication Receivers due to Superregenerative Receiver Radiation

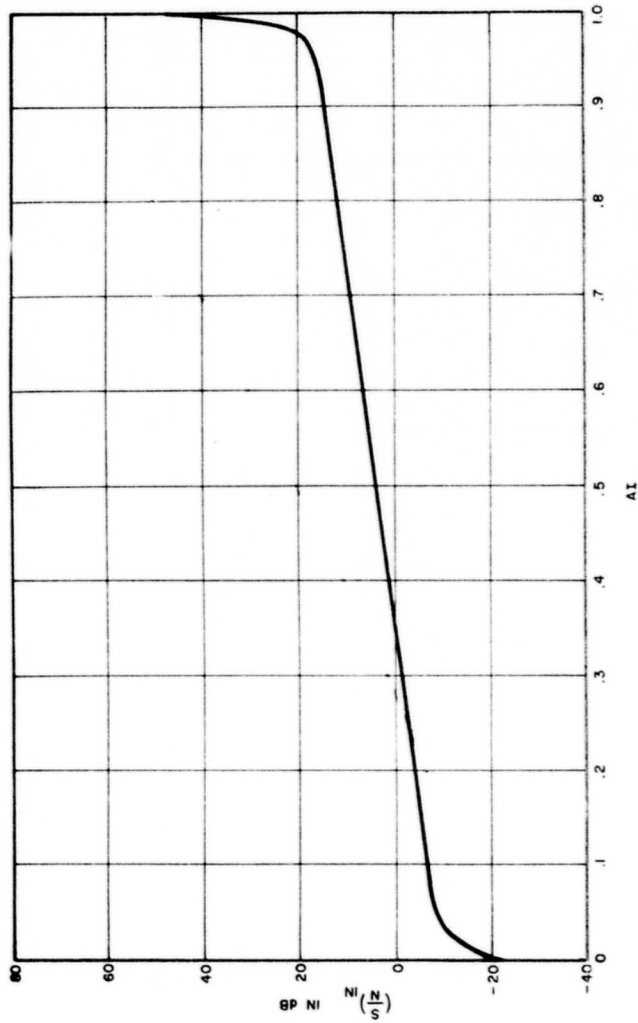

Figure 3-9. The Effect of Radiations from Superregenerative Receivers on Articulation Index in Communications Receivers

produce an AI of .5, .7, or .9 for interference from dielectric heaters and superregenerative receivers. The results shown in this table will be used in Section 4 to assess the degradation to the aeronautical VHF communication services.

**TABLE 3-1**  
**INPUT S/I (dB) FOR COMMUNICATION RECEIVERS**  
**FOR VARIOUS ARTICULATION INDICES**

Interferer	Input S/I (dB)					
	Fast Sweep (> 50 kHz/s)			Slow Sweep (< 5 kHz/s)		
	AI 0.5	AI 0.7	AI 0.9	AI 0.5	AI 0.7	AI 0.9
Dielectric Heater	-11	-5	0	1	7	18
Superregenerative Receiver	4	10	16	4	10	16

(all S/I are for one input S/N = 66 dB.)

**ILS LOCALIZER NAVIGATION RECEIVER DEGRADATION**

**Receiver Model**

The IF stages of the ILS localizer navigation receiver were modeled in the same manner as the communication receiver; however, the audio stages are different. The synthesis of the audio stages will be developed below. A simplified block diagram of the audio stages of this navigation receiver is shown in Figure 3-10.

Section 2 described the overall receiver operation; therefore, only the audio will be described in detail here.

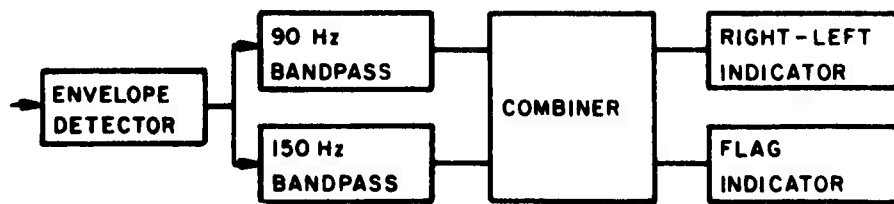

Figure 3-10. Block Diagram of the Audio Stages of the ILS Localizer Navigation Receiver

The amplitudes of the desired 90 Hz and 150 Hz tones are rectified and added in the combiner. The resultant  $\pm$  dc level operates the RIGHT-LEFT indicator meter. When the sum of the amplitudes of the two tones exceeds a preset level, the "flag" disappears.

The receiver audio selectivity consists of two tuned circuits centered at 90 Hz and 150 Hz with 3 dB bandwidths equal to one half the tuned frequency, and an amplitude vs. frequency slope of 6 dB/octave. Figure 3-11 is a block diagram of the simulated ILS localizer receiver. The figure shows where the S/I, S/N and S/(N + I) are referenced. The modeled selectivity curve is shown in Figure 3-12. Because the two selectivity curves intersected at a level only 3 dB below the maximum level, a simplified model was used which consisted of a high pass filter and low pass filter with 3 dB points at 70 Hz and 190 Hz respectively. Measurements of the actual receiver selectivity are plotted on Figure 3-12 for comparison.

#### **Desired Signal**

The desired signal for the ILS localizer consists of a VHF carrier frequency 30% amplitude modulated by a 90 Hz and 150 Hz tone. Since the RWS was developed to use a single desired tone, the desired input selected was a carrier frequency amplitude-modulated 30% by a 150 Hz tone.

#### **Measurement Observations**

It was observed during the degradation measurements that the dielectric heater interference to the ILS Localizer Navigation Receiver was caused by the modulation sidebands of the dielectric heater signal instead of the sweeping beat note between the desired and interfering carriers as noted previously in the communication receiver. This observation is better understood by realizing that the slowly varying beat frequency will not remain in the audio pass band long enough to allow the indicator to respond. For example, if the dielectric signal frequency sweep rate is 1 kHz/sec (low for dielectric heaters) the beat note will remain in a 100 Hz audio passband for only 0.1 seconds. Using the same example, the significant interfering modulation sidebands will remain in the audio passband of a 40 kHz IF passband receiver for 40 seconds.

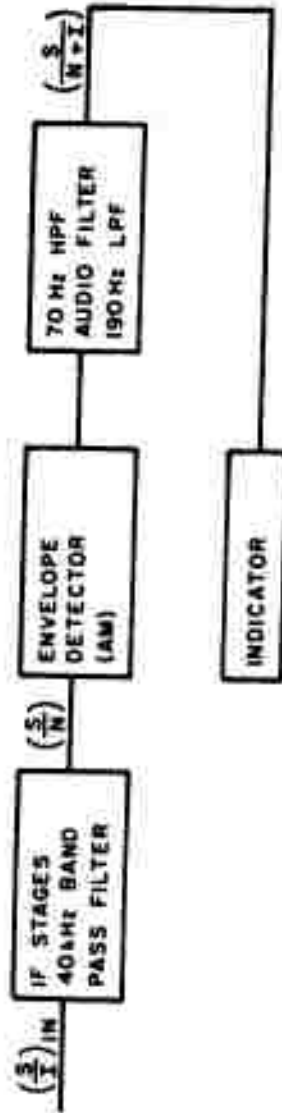

Figure 3-11. Simulated ILS Localizer Receiver Diagram

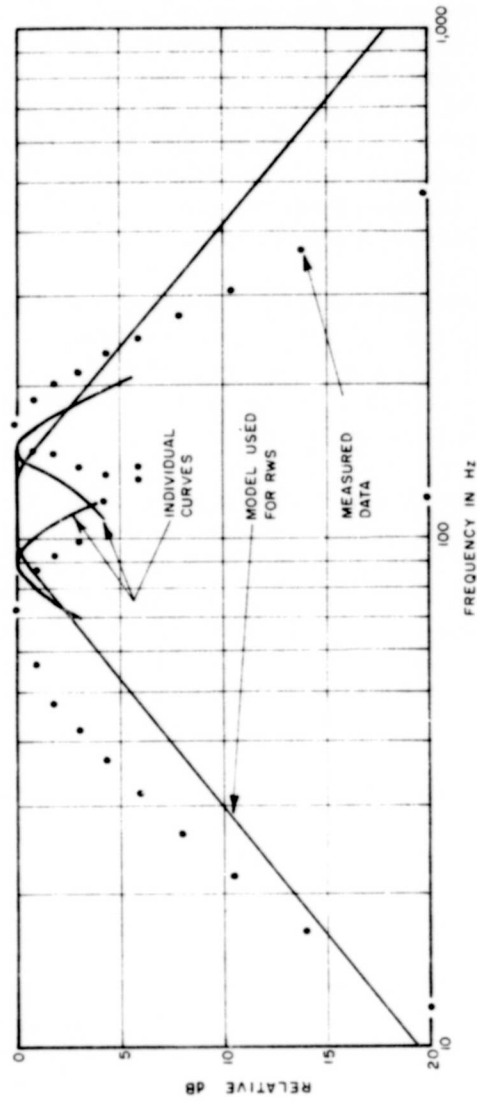

Figure 3-12. Localizer Navigation Receiver Audio Stage Model

### Dielectric Heater Interference

The RWS model results are plotted in Figure 3-13 for desired input Signal-to-Noise (S/N) ratios of 20 dB and 66 dB when the interfering source is a dielectric heater. Measured results are also shown in Figure 3-13 so that indicator interference can be assessed. When the interfering signal is modulated by a three-phase half-wave signal, measurements indicate that a receiver input S/I ratio between 4 dB and 6 dB results in a ½ dot response and corresponds to an output S/(N + I) ratio between 6 dB and 8 dB. These three-phase half-wave results are applied to the three-phase full-wave curve on Figure 3-13 so that the S/I ratio between 6 dB and 8 dB can be determined. In a similar manner the input S/I ratio for three-phase full-wave interference is determined for 3 dot and 5 dot responses.

The presence of the dielectric heater signal produces low frequency noise and interference in the output of the receiver from below 90 Hz to above 150 Hz. If the frequencies of the (N + I) energy are above 150 Hz, as in the case of three-phase interference, the indicator meter will deflect in one direction; if below 90 Hz, meter deflection in the opposite direction will occur.

If the interfering dielectric heater is modulated by either a full- or half-wave three-phase signal, all modulation sideband frequencies will be above 150 Hz. For these cases an audio output S/(N + I) ratio of between 6 and 8 dB will cause a half-dot indicator movement. However, for the single-phase full-wave modulation case, the predominant sideband frequency is 120 Hz. Since the sideband frequencies lie between the 90 and 150 Hz peaks of the receiver audio filters, the interference has much less effect. The measured results indicate this phenomenon; an audio output S/(N + I) ratio between -4 and -2 dB produces the half dot deflection.

As the S/(N + I) ratio three-phase half-wave modulation changes from +6 to -12 dB, the indicator moves from ½ dot to 5 dot deflection. This relationship was confirmed through measurements and is presented in Figure 3-13.

### Superregenerative Receiver Interference

Figure 3-14 shows the RWS results when the interfering source has the broad-band random noise signal characteristics of the superregenerative receiver radiation.

The amplitude of the interfering random noise is evenly distributed in

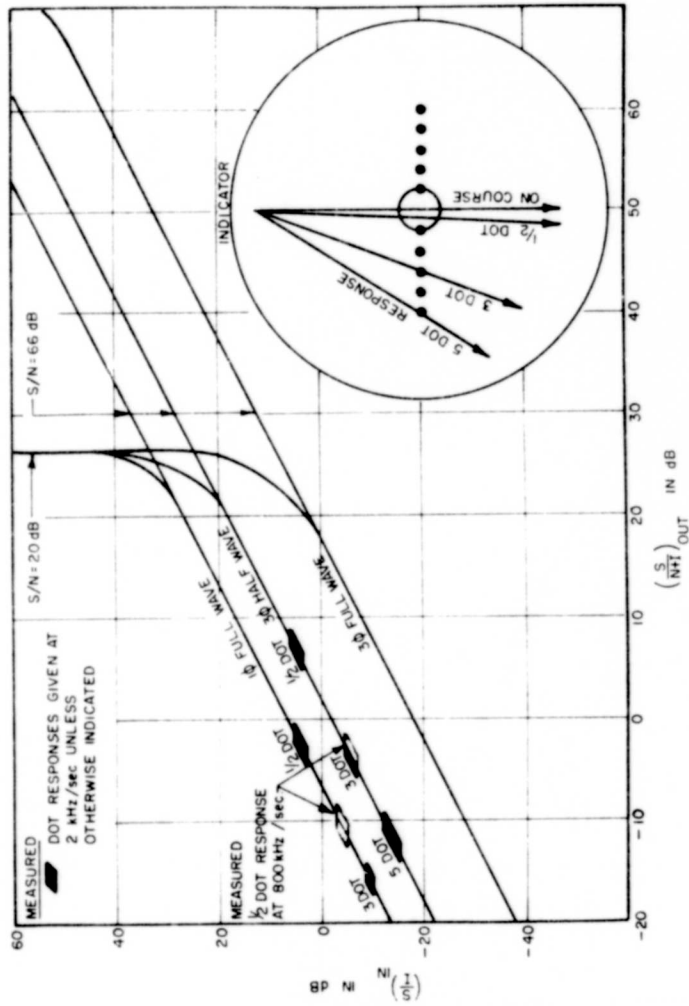

Figure 3-13. Analytical Localizer Navigation Receiver Degradation due to Dielectric Heater

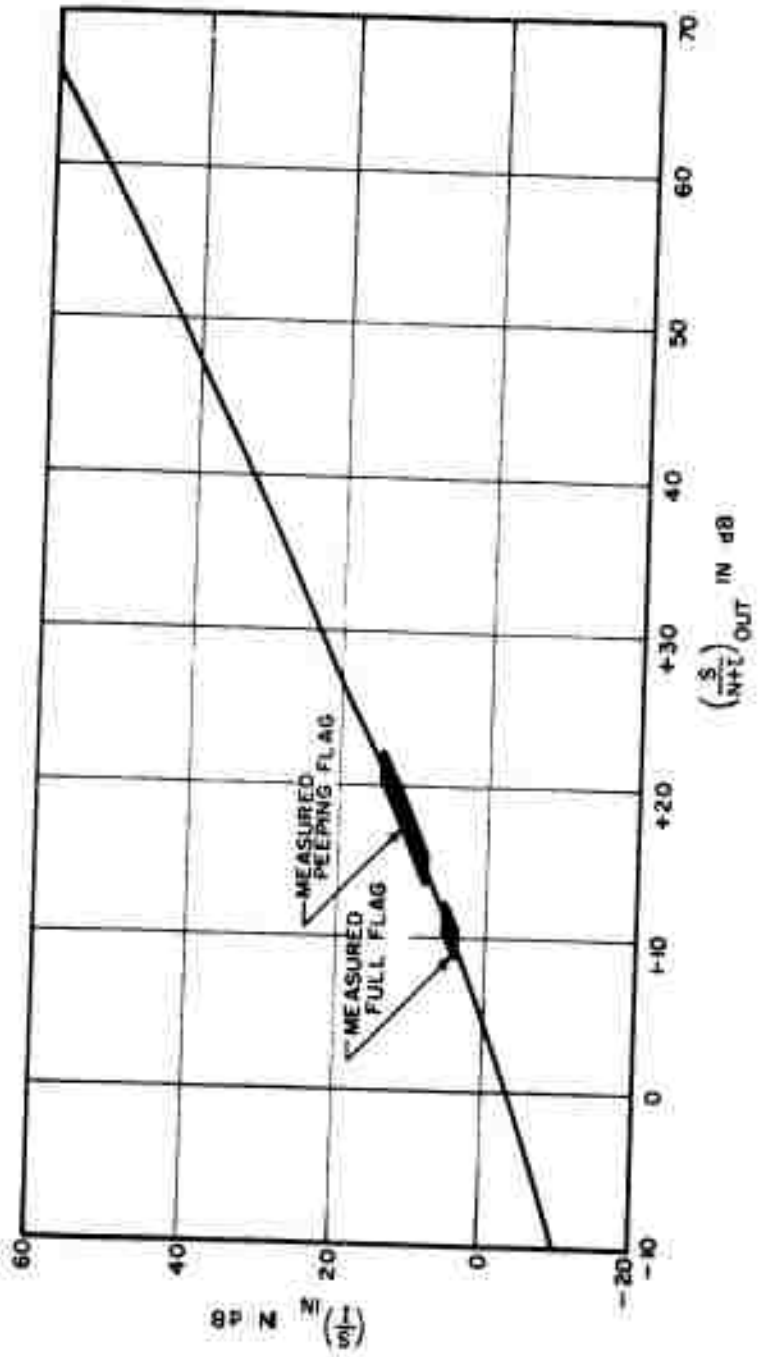

Figure 3.14. Analytical Degradation to ILS/Localizer Receivers due to Superregenerative Receiver Radiations.

frequency and produces approximately equal levels of energy at the outputs of the 150 Hz and 90 Hz filters. Consequently, the noise interfering source does not cause the indicator to deflect predominantly in one direction. The noise interference does cause the flag, normally in the "TO" position, to move to the "peeping flag" position (flag just begins to move) or the "full flag" or "OFF" position. The measured S/I input ratios that produce a "peeping flag" and "full flag" condition are shown in Figure 3-14.

**Summary of ILS/LOC Receiver Degradation**

TABLE 3-2 lists the input Signal-to-Interference (S/I) ratios that produce ½, 3 and 5 dot deflections caused by dielectric heater interference; also shown are the input S/I ratios that result in flag responses caused by interference from a superregenerative receiver. The results shown in this table will be used in Section 4 to assess the interference to the ILS localizer services.

**TABLE 3-2**

**INPUT S/I RATIOS FOR DOT AND FLAG RESPONSES  
FOR INPUT S/N RATIO = 66 dB**

Interferers	S/I in dB				
	Dot Responses			Flag Responses	
	½ dot dB	3 dot dB	5 dot dB	Peeping dB	Full dB
<b>Dielectric Heater</b>					
1 φ Full wave	3 to 5	-10 to -9		3 to 5	no data
3 φ ½ wave	4 to 6	-7 to -5	-15 to -12	4 to 6	no data
3 φ Full wave	-12 to -10	-23 to -21		-12 to -10	no data
<b>Superregenerative Receiver</b>	*	*	*	8 to 14	4 to 5

\* no response (see discussion on page 3 22)

## VOR NAVIGATION RECEIVER DEGRADATION

### Receiver Model

The IF stages of the VOR receiver were modeled in the same manner as the communications receiver. The synthesis of the audio stages is developed below. A simplified block diagram of the audio stages of the VOR receiver is shown in Figure 3-15.

Section 2 described the overall receiver operation; therefore, only the audio stages will be described in detail here.

The detector output consists of a variable-phase 30 Hz tone and a 9960 Hz signal frequency-modulated with another 30 Hz tone. The 9960 Hz signal is slope-detected and the reference phase of its detected 30 Hz tone is compared with the phase of the 30 Hz tone of the variable phase channel. This comparison takes place in the RIGHT-LEFT discriminator and any phase difference will cause the meter needle to respond to the right or left. The phase comparison also takes place in a "TO-FROM" discriminator and a 180° phase change will cause the flag to change from "TO" to "FROM", and vice versa.

*Measurement Observations.* It was observed that an interfering signal always caused the "RT-LF" indicator to move to the left. This was caused by interfering signals degrading the reference phase channel more than the variable phase channel. The bandwidth of the variable phase channel was approximately 30 Hz whereas the bandwidth of the reference phase channel, before the limiter, was approximately 14,000 Hz. Consequently, interfering signals distributed over the 20 kHz audio baseband would concentrate much more energy in the reference phase channel than in the variable phase channel.

### Desired Signal

The VOR signal consists of a 30 Hz reference tone that deviates a 9960 Hz subcarrier approximately 480 Hz.\* The subcarrier amplitude modulates the carrier frequency 30%. Additionally, a 30 Hz variable-phase tone amplitude-modulates the carrier 30%. The resulting signal is expressed in Equation (3-1).

---

\* In the only available VOR simulator (the SG-13 illustrated in Figure B-1, APPENDIX B), the deviation was approximately 900 Hz.

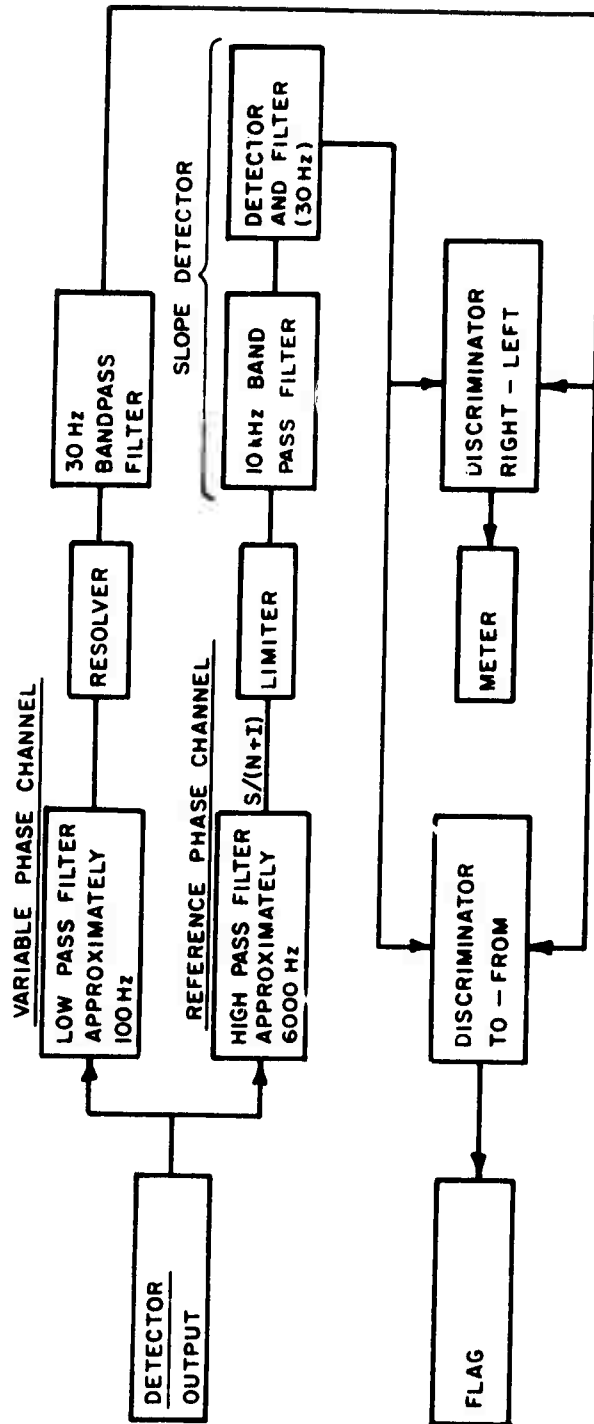

Figure 3-15. VOR Navigation Receiver Audio Stages

$$e = \left\{ 1 + .3 \cos (2 \pi 9960t + \beta \sin 2 \pi 30.t) + .3 \cos (2\pi 30t + \phi) \right\} \cos 2\pi f_o t \quad (3-1)$$

where,

$e$  = VOR input signal

$\beta$  = modulation index

$\phi$  = variable phase shift

$t$  = time in sec

Since the interference was observed to occur in the reference phase channel, Equation 3-1 was simplified for use with the RWS model. The equation used as the desired signal input to the RWS was:

$$e = (1 + .3 \cos 2 \pi 9960t) \cos 2 \pi f_o t \quad (3-2)$$

and the output  $S/(N + I)$  was referenced to the input of the limiter.

Figure 3-16 shows the simulated VOR receiver system diagram and reference points for  $S/I$ ,  $S/N$  and  $S/(N + I)$  ratios.

Using the above desired signal as input to the RWS model and the dielectric heater as the interference, the model was run for various  $S/I$  ratios. These results for the VOR navigation receiver are shown in Figures A-16 through A-21 (APPENDIX A).

### Dielectric Heater Interference

Since the low pass (100 Hz) variable phase channel has been determined previously to be relatively immune from interference, any interference effects will be due largely to the reference phase channel. In all cases the interference is caused by the beat note between the desired and interfering carriers as determined by measurements and RWS model analysis. As the interfering carrier sweeps through the receiver IF passband, its beat frequency with the desired carrier remains in the reference phase channel audio passband 70% of the time. This figure is obtained by,

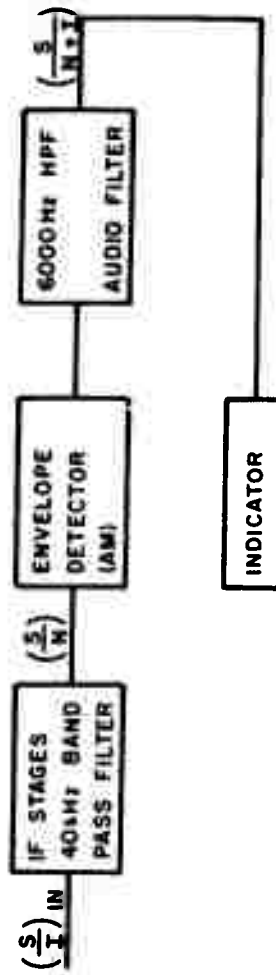

Figure 3-16. Simulated VOR Receiver Diagram

$$70\% = \left( \frac{\frac{1}{2} BW_{IF} - HPF}{\frac{1}{2} BW_{IF}} \right) 100 \quad (3-3)$$

where

$BW_{IF}$  = IF bandwidth = 40 kHz

HPF = high pass filter cutoff frequency = 6 kHz

Since the beat note remains in the reference phase channel audio passband for a large percentage of the time, the RWS result at  $\Delta f = 10$  kHz was selected to represent the amount of dielectric heater degradation to a VOR navigation receiver. This result is shown on Figure 3-17 for desired levels of  $5 \mu V$  and  $1,000 \mu V$  which correspond to input S/N ratios of 20 dB and 66 dB respectively.

From the tests, S/I input ratios were measured that cause a one degree bearing shift response and a full flag response. These S/I ratios, which correspond to an interfering frequency sweep rate of 10 kHz/sec, are shown on Figure 3-17.

Tests also indicated that, as the sweep rate was increased, the interference effects were lowered, resulting in a lower input S/I ratio required for a constant receiver output response (Figure B-11). Specifically, the input S/I ratios had to be decreased 10 dB when the sweep rate was increased from 10 kHz/sec to 800 kHz/sec.

#### **Superregenerative Receiver Interference**

Figure 3-18 shows the RWS model results when the interfering source has the broadband random noise signal characteristic of the superregenerative receiver radiation. Included also in the figure are the measured input S/I ratios for a one degree bearing change and a "full flag" response.

#### **Summary of VOR Navigation Receiver Degradation**

TABLE 3-3 lists the input signal-to-interference S/I ratios that produce a one degree indicator deflection and a full flag response caused by interference from dielectric heaters and superregenerative receivers. The results shown in this table will be used in Section 4 to assess the interference to the VOR navigation services.

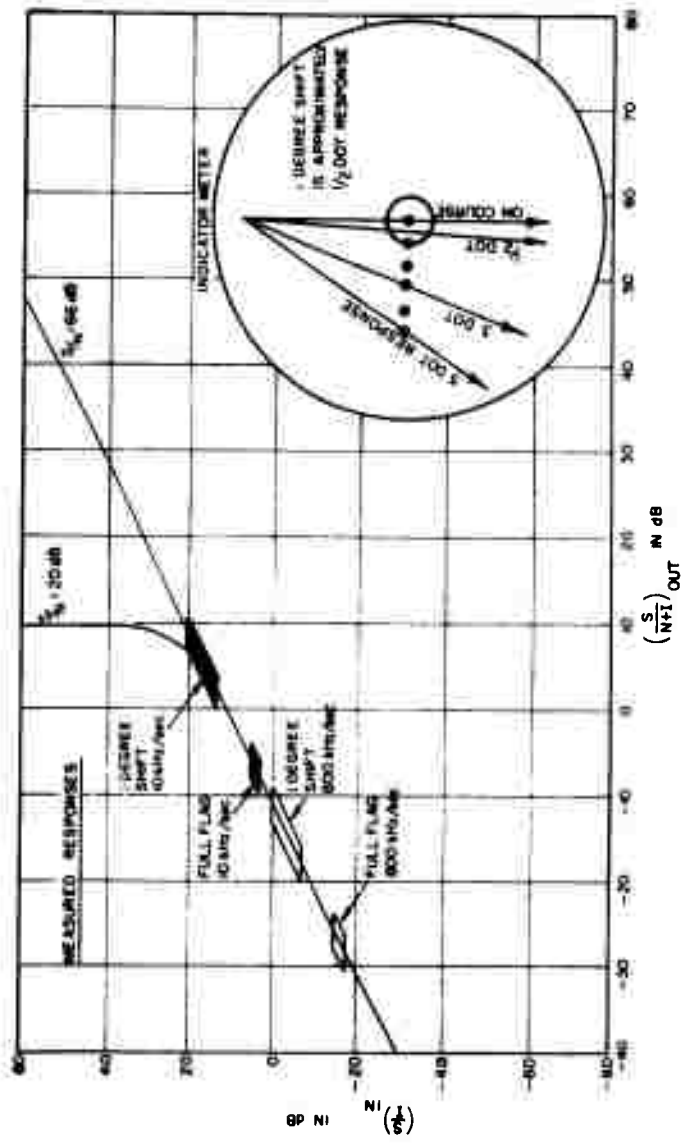

Figure 3-17. Analytical Degradation to a VOR Navigation Receiver from Dielectric Heater Emissions

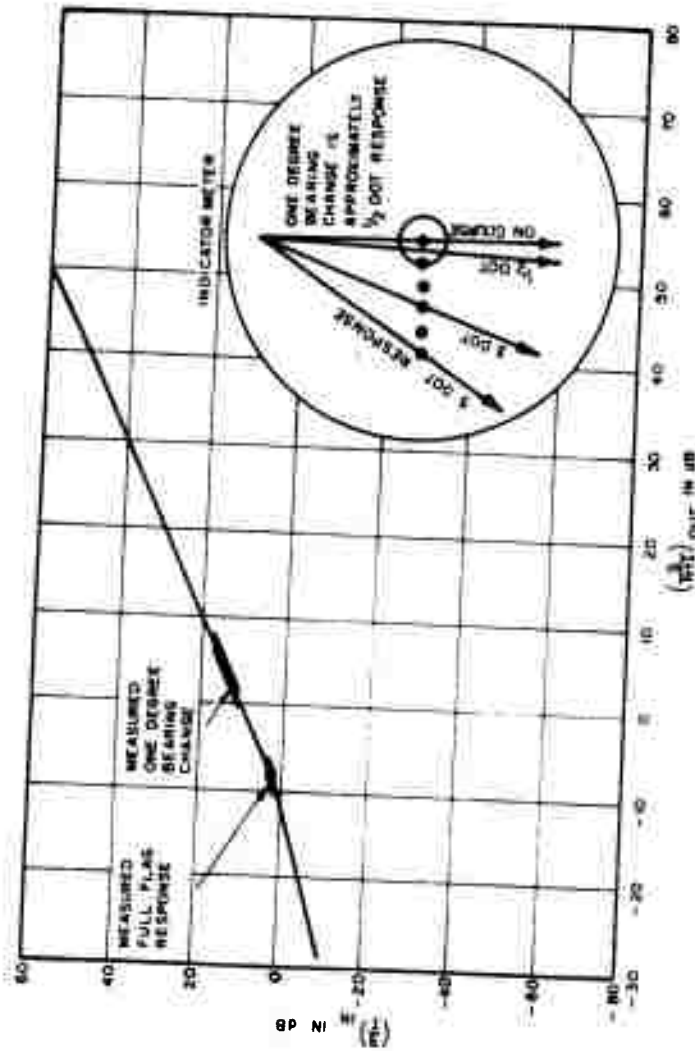

Figure 3-18. Analytical Degradation to a VOR Navigation Receiver from Superregenerative Receiver Radiations

TABLE 3-3

INPUT S/I (IN dB) FOR TWO INDICATOR RESPONSES  
FOR INPUT S/N RATIO = 66 dB

Interferers	S/I in dB	
	Indicator Meter Responses	
	One degree shift	Full flag response
Dielectric heater sweeping at 10 kHz/sec	13 to 20	3 to 5
Dielectric heater sweeping at 800 kHz/sec	-7 to 0	-17 to -15
Superregenerative Receiver	11 to 17	2 to 3

SUMMARY OF COMMUNICATION AND NAVIGATION  
RECEIVER DEGRADATION

Dielectric heater interference to COMM/NAV receivers may be separated into two categories. The first is a sweeping beat note due to the interfering and desired carriers. The second is caused by the modulation sidebands of the interfering carrier. Superregenerative receiver interference to COMM/NAV receivers is caused by the interfering signal adding random noise to the receiver baseband noise. Input S/I ratios required to degrade COMM/NAV receivers are listed in TABLE 3-4.

Degradation to the communication receiver is due to the sweeping beat note when the interfering carrier is sweeping slowly (< 5 kHz/sec). When the carrier is sweeping fast (> 50 kHz/sec) the degradation is due to the modulation sidebands. The sweep rate at which the beat note and the modulation sideband contribute equally to the receiver degradation depend upon input S/I ratio, modulation type, audio bandwidth and method used to determine degradation. Consequently, only the slow sweep and fast sweep cases were presented. The superregenerative receiver will degrade the communication receiver by adding random noise to the communication receiver baseband noise.

**TABLE 3-4**  
**INPUT (S/I) IN dB REQUIRED TO DEGRADE COMMUNICATION**  
**AND NAVIGATION RECEIVERS FOR VARIOUS INTERFERERS**

Interferer	S/I in dB									
	Dielectric Heater					Superregenerative Receiver (Random noise)				
	Slow Sweep (< 5 kHz/sec)					Fast Sweep (> 50 kHz/sec)				
Output Response	1 $\phi$ full wave	3 $\phi$ half wave	3 $\phi$ full wave	1 $\phi$ full wave	3 $\phi$ half wave	3 $\phi$ full wave	1 $\phi$ full wave	3 $\phi$ half wave	3 $\phi$ full wave	Superregenerative Receiver (Random noise)
Communication Receiver AI = .5 AI = .7 AI = .9	7	7	7	-11	-11	-11	-11	-11	-11	4
	13	13	13	-5	-5	-5	-5	-5	-5	10
	20	20	20	0	0	0	0	0	0	16
ILS LOC Navigation Receiver 1/2 dot 3 dot 5 dot peeping flag full flag	4	5	-11	-4	-6	-22	-4	-6	-22	**
	-9	-6	-22	**	**	**	**	**	**	**
	**	-13	**	**	**	**	**	**	**	**
	***	***	***	***	***	***	***	***	***	11
VOR Navigation Receiver 1 degree shift full flag	17	17	17	-3	-3	-3	-3	-3	-3	14
	4	4	4	-16	-16	-16	-16	-16	-16	2

\*\* Unable to obtain response  
 \*\*\* S/I required for 1/2 flag response is approximately equal to S/I required for 1/2 dot response

Degradation to the ILS localizer navigation receiver is due primarily to the modulation sidebands of the dielectric heater. Sidebands of the three-phase signal will cause the energy in the 150 Hz tone channel to increase and produce an erroneous bearing indication. Sidebands of the single-phase full-wave signal will cause the energy in both the 90 Hz and 150 Hz tone channels to increase. An erroneous flag indication will appear when the interfering signal shifts the bearing indication approximately  $\frac{1}{2}$  dot. Superregenerative receiver noise will be equally distributed in the audio passband and will not cause severe deflections of the bearing indication. However, an erroneous flag indication will be seen for average input S/I ratio levels less than 14 dB.

Degradation to the VOR navigation receiver is due to the sweeping beat note of the desired and interfering carriers. An erroneous one degree bearing indication will occur at interfering levels approximately 13 dB less than those levels required to cause an erroneous flag indication. Superregenerative noise has approximately the same effect on the VOR navigation receiver as the sweeping beat note.

## SECTION 4

APPLICATION OF DEGRADATION CRITERIA TO VHF COMMUNICATION  
AND NAVIGATION SERVICES

It was demonstrated in the previous section of this report that radiation from dielectric heaters and superregenerative receivers can interfere with VHF communication and navigation receivers. The following development will determine the degree of degradation to these receivers in operational service. The existing regulatory limits controlling the amount of radiation from dielectric heaters and superregenerative receivers will be employed.

## DEGRADATION TO COMMUNICATION SERVICES

## Dielectric Heater Interference to Airborne Receivers

*Radiation Limit.* The present limit for field strength radiated by a dielectric heater is  $10 \mu\text{V/m}$  at 5280 feet. Based on the basic transmission loss curves in Figure 4-1, a dielectric heater that produced  $10 \mu\text{V/m}$  at one mile would have an effective radiated power of +15 dBm at 110 MHz.

To determine what the equipment field strength is at horizontal distances less than 5280 feet, the following equation is employed.

$$E \text{ (at X feet)} = E \text{ (at 5280 feet)} + \Delta L_b \quad (4-1)$$

where

$$E \text{ (at 5280 feet)} = 10 \mu\text{V/m or } 20 \text{ dB}/\mu\text{V/m}$$

$$\Delta L_b = \text{difference in basic transmission losses for 5280 feet and X feet.}$$

In Figure 4-1, which was excerpted from Reference 3, basic transmission loss curves for a family of frequencies are shown. The curves were developed using the N  $\lambda$  Propagation Model described in Reference 6. For an X distance of 40 feet and a frequency of 110 MHz,  $\Delta L_b$  (from Figure 4-1) is 78 dB. Therefore, the field strength at 40 feet =  $20 \text{ dB}/\mu\text{V/m} + 78 \text{ dB} = 98 \text{ dB}/\mu\text{V/m}$ ;  $98 \text{ dB}/\mu\text{V/m} = 80,000 \mu\text{V/m}$ .

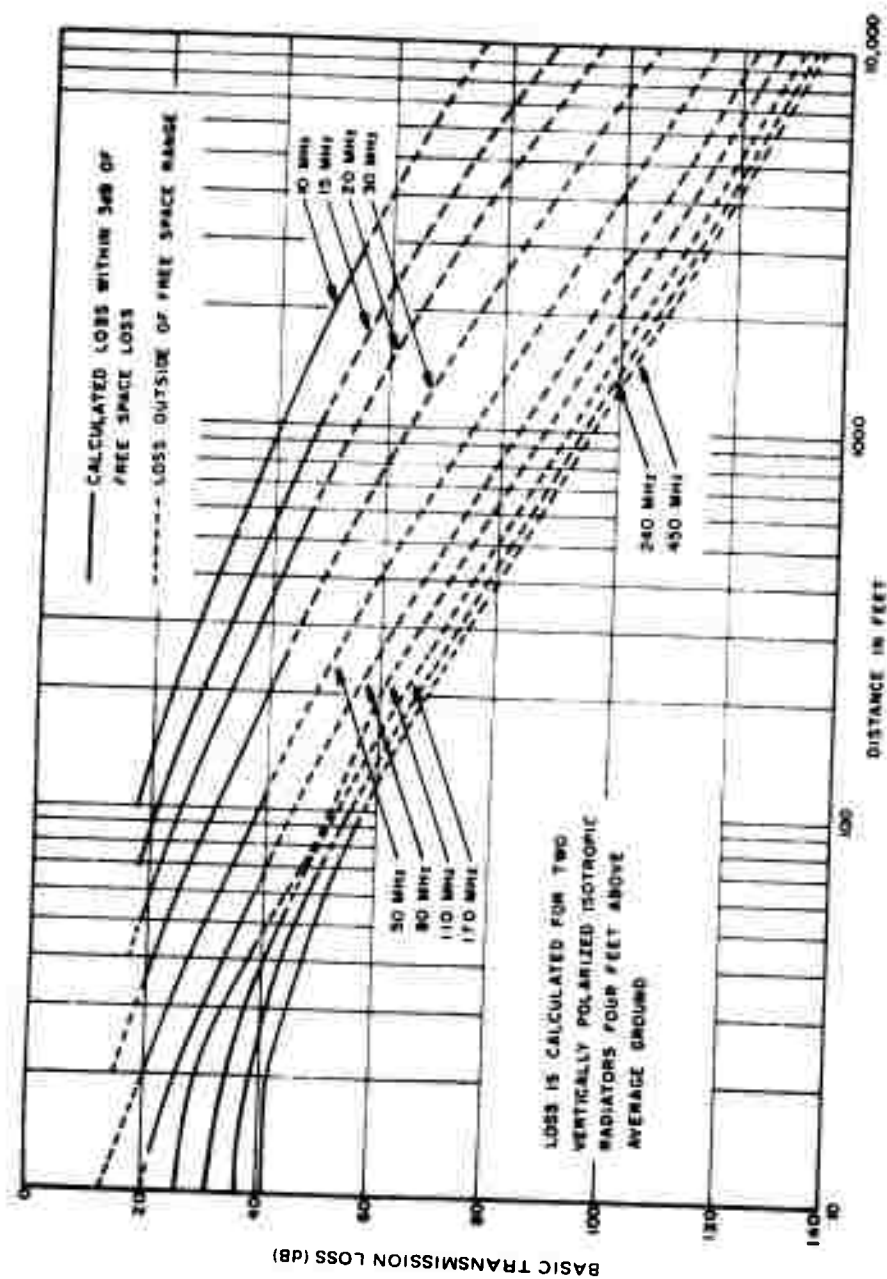

Figure 4-1. Basic Transmission Loss

*Description of the Aircraft Flight Profiles.* For the purpose of analyzing the degradation to the airborne receivers, two flight profiles have been chosen for the analysis.

*Case 1.* It is assumed that the aircraft flies at a cruise altitude of 4 nautical miles and begins its descent when 60 nautical miles from the airfield. The aircraft descends to an altitude of one half nautical mile when 20 nautical miles from the airfield and maintains the one half nautical mile altitude until starting its final descent 5 nautical miles from the airfield.

*Case 2.* It is assumed that the aircraft flies at a cruise altitude of one nautical mile and begins its descent when 26 nautical miles from the airfield. The remaining approach is identical to Case 1.

*Determination of Receiver Signal-to-Interference Ratio.* It is assumed that the ground communication transmitter has an effective radiated power of 25 watts (+ 44 dBm) and an antenna height of 50 feet. The input Signal-to-Interference ratio (S/I) at the airborne receiver is given in the following equation (See APPENDIX C for derivation):

$$S/I = 29 + 20 \log \frac{d_i}{d_s}, \quad (\frac{1}{2} \leq d_s \leq 125 \text{ for Case 1}) \quad (4-2)$$

$$(\frac{1}{2} \leq d_s \leq 55 \text{ for Case 2})$$

where

$d_s$  = desired signal path distance

$d_i$  = interfering signal path distance

Free space propagation loss is assumed.

It is assumed that the interfering dielectric heater is always directly below the aircraft for each calculation of S/I. Because of the geometry of the flight path,  $d_s$  is assumed equal to the horizontal distance between the airfield and the aircraft. Equation 4-2 is rewritten in four sections to correspond to the four sections of the flight profile shown at the bottom of Figure 4-2.

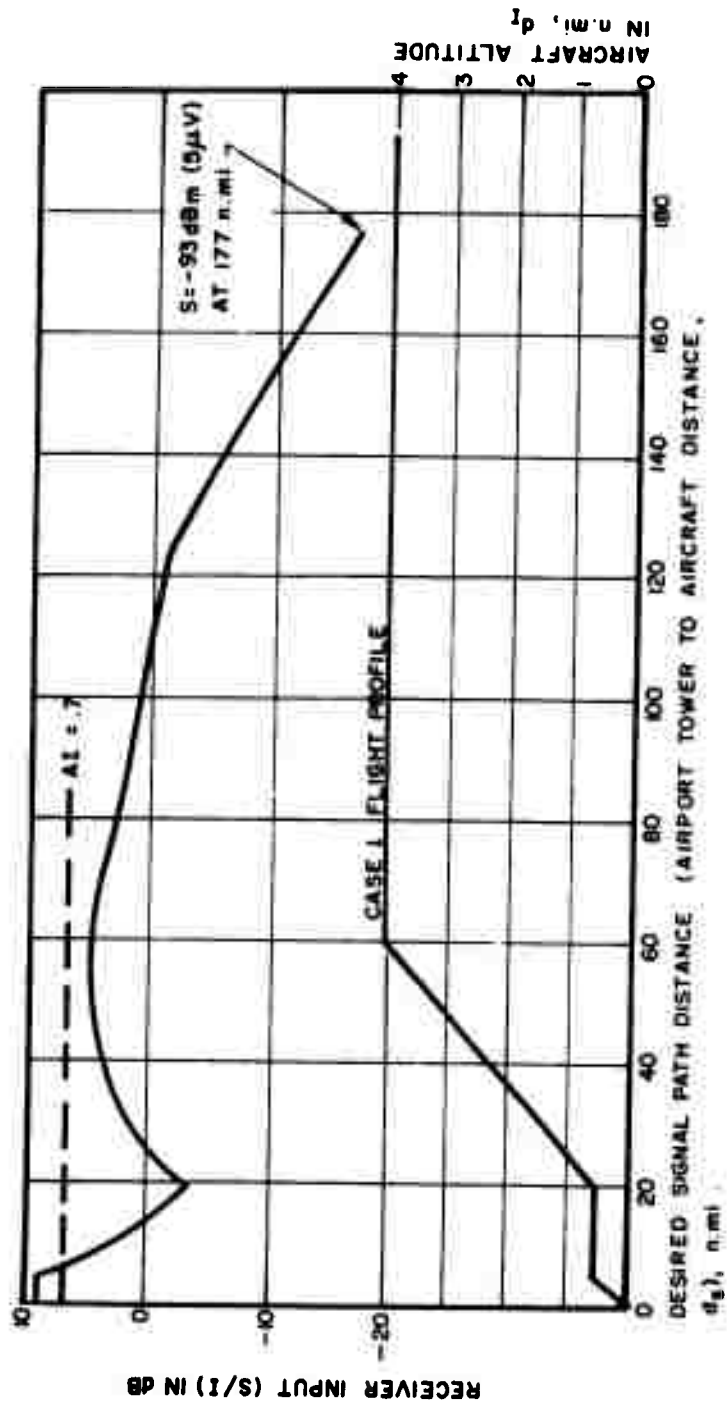

Figure 4-2. Communication Receiver Input Signal-to-Interference Ratio at Various Aircraft Locations for a Dielectric Heater Radiation of 10 μV/meter at 5280 feet.

For Case 1.

$$\frac{S}{I} = 9 \text{ dB}, \frac{1}{2} \leq d_s \leq 5 \text{ miles} \quad (4-2A)$$

$$\frac{S}{I} = 29 - 20 \log 2d_s, 5 \leq d_s \leq 20 \text{ miles} \quad (4-2B)$$

$$\frac{S}{I} = 29 + 20 \log \frac{7 d_s - 100}{80 d_s}, 20 \leq d_s \leq 60 \text{ miles} \quad (4-2C)$$

$$\frac{S}{I} = 29 - 20 \log \frac{d_s}{4}, 60 \leq d_s \leq 125 \text{ miles} \quad (4-2D)$$

Input S/I ratios calculated using Equations 4-2A through 4-2D for ranges out to 125 nautical miles are plotted in Figure 4-2. Beyond 125 nautical miles those equations are no longer valid because of the effects of earth curvature. For ranges between 125 and 190 nautical miles, FAA transmission loss curves were employed to determine the S/I ratio (Reference 7, Figure A-5).

The degradation threshold of the airborne communications receiver to maintain an Articulation Index (AI) of .7 (Reference 5), is plotted as a dashed horizontal line. At distances where the input S/I ratio is below the dashed line, interference from dielectric heaters is expected.

For Case 2.

$$\frac{S}{I} = 9 \text{ dB}, \frac{1}{2} \leq d_s \leq 5 \text{ miles} \quad (4-2E)$$

$$\frac{S}{I} = 29 - 20 \log 2 d_s, 5 \leq d_s \leq 20 \text{ miles} \quad (4-2F)$$

$$\frac{S}{I} = 29 + 20 \log \frac{d_s - 14}{12 d_s}, 20 \leq d_s \leq 26 \text{ miles} \quad (4-2G)$$

$$\frac{S}{I} = 29 - 20 \log d_s, \quad 26 \leq d_s \leq 55 \text{ miles} \quad (4-2H)$$

The input S/I ratios to the airborne communications receiver are calculated out to a range of 55 nautical miles using Equations 4-2E through 4-2H. Because of the earth's curvature the transmission loss curves of Reference 7, Figure A-2, were employed to determine the S/I ratios from 55 out to 98 nautical miles.

The Case 2 flight profile and the resulting input S/I ratios are plotted in Figure 4-3. The dashed horizontal lines indicate the degradation threshold for an Articulation Index (AI) of .7.

*Prevention of Interference.* To prevent the receiver input signal-to-interference ratio from being degraded less than the AI = .7 threshold, the interference level must be decreased by 36 dB. The reduction factor is obtained from Figure 4-3 by subtracting the level that produces an AI = .7 (+7 dB) from the level that produces the minimum S/I ratio, -29 dB. A reduction in the limit level of 36 dB corresponds to a reduction of the present limit of 10  $\mu\text{V}/\text{m}$  at 5280 feet to 0.6  $\mu\text{V}/\text{m}$  at 5280 feet. In terms of the limit measured at 100 feet, the reduction would be from 84 dB/ $\mu\text{V}/\text{m}$  to 48 dB/ $\mu\text{V}/\text{m}$ .

#### Dielectric Heater Interference to Ground Receivers

*Radiation Limit.* A radiation limit of 10  $\mu\text{V}/\text{m}$  at 5280 feet, as in the case of interference to airborne receivers, is employed.

*Description of Flight Profile.* The flight profile of Case 2 is employed. This flight profile now determines what the desired signal level at the ground communication receiver will be.

*Determination of Input Signal to Interference (S/I) Ratio.* The Effective Radiated Power (ERP) of the airborne communications transmitter is assumed to be +44 dBm. The ERP of the dielectric heater radiating at the limit is +15 dBm. Basic transmission loss for the desired signal between the aircraft and the ground station receiver (50 foot high antenna) follows free space phenomenon out to 55 nautical miles. Because of the earth's curvature, transmission loss between 55 and 97 nautical miles was determined from Figure A-2 of Reference 7. The basic transmission loss between the interfering dielectric heater and the ground receiver was determined by a theoretical ground wave prediction model (Reference 6).

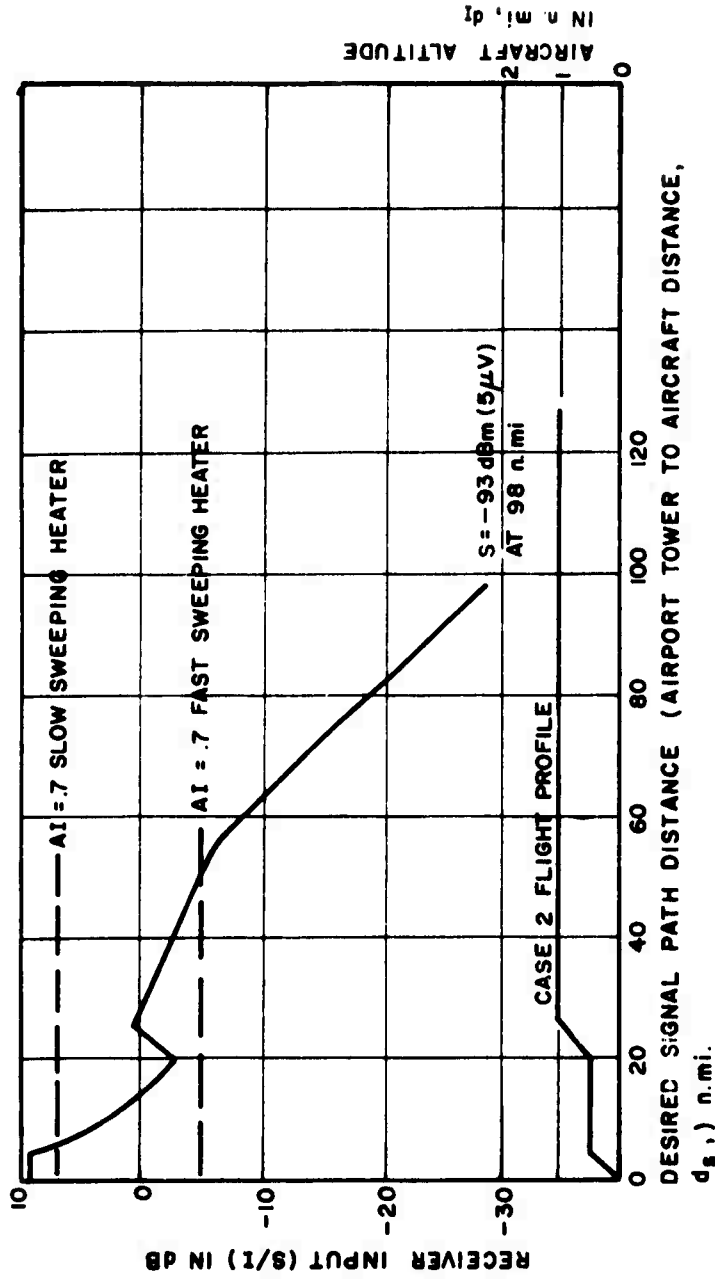

Figure 4-3. Communication Receiver Input Signal-to-Interference Ratio at Various Aircraft Locations for a Dielectric Heater Radiation of  $10 \mu\text{V}/\text{meter}$  at 5280 feet

The receiver input S/I ratios were determined by using Equation 4-3:

$$\frac{S}{I} = 29 - L_{P_s} + L_{P_i}, \quad (4-3)$$

where  $L_{P_s}$  and  $L_{P_i}$  are the transmission losses of the desired and interfering signals respectively. The constant 29 dB is the difference between the desired ERP (+44 dBm) and the dielectric heater ERP (+15 dBm).

Equation (4-3) was solved for interfering distances of  $\frac{1}{2}$ , 1, 2 and 4 nautical miles and the results are shown on Figure 4-4. Degradation thresholds listed in Figure 4-4 determine the articulation index as a function of the desired and interfering signal distances. For example, for an aircraft transmitting 65 nautical miles from the ground station an articulation index of 0.7 will result due to a dielectric heater 0.5 nautical miles removed from the ground station tower. The AI will decrease to 0.5 at about 75 nautical miles and continue to deteriorate beyond 75 nautical miles.

*Prevention of Interference.* To prevent the receiver input S/I from being less than 7 dB (AI = .7) when the desired input level is  $5 \mu\text{V}$ , either one of two steps may be taken.

1. The dielectric heater, radiating  $10 \mu\text{V}/\text{meter}$  at 5280 feet, should be at distances greater than 1.5 nautical miles from the ground station antenna.
2. The dielectric heater interfering level (I) should be decreased by 17.5 dB so that a dielectric heater may be located as close as .5 nautical miles from the ground station antenna. The 17.5 dB is obtained from Figure 4-4 by subtracting -10.5 dB (the S/I that occurs at  $5 \mu\text{V}$ ) from 7 dB (the S/I tha. causes AI = .7).

#### **Superregenerative Receiver Interference to Airborne Receivers**

*Radiation Limit.* The present radiation limit at VHF frequencies for superregenerative receivers (Garage Door Opener Receivers) is  $50 \mu\text{V}/\text{m}$  at 100 feet, measured with a receiver of 200 kHz bandwidth. This limit is for peak voltage density and corresponds to peak Effective Radiated Power (ERP) of -41 dBm in a 200 kHz bandwidth. This value is converted to average power by subtracting 14 dB, resulting in an average ERP of -55 dBm in a 200 kHz bandwidth [see Equation (2-8), Reference 3]. A further correction must be made to equate the power to the airborne receiver bandwidth of 40 kHz. The bandwidth correction factor would be  $\frac{200}{40} = 5$ , or 7 dB. The limit, therefore, in terms of average ERP in a 40 kHz bandwidth is -62 dBm.

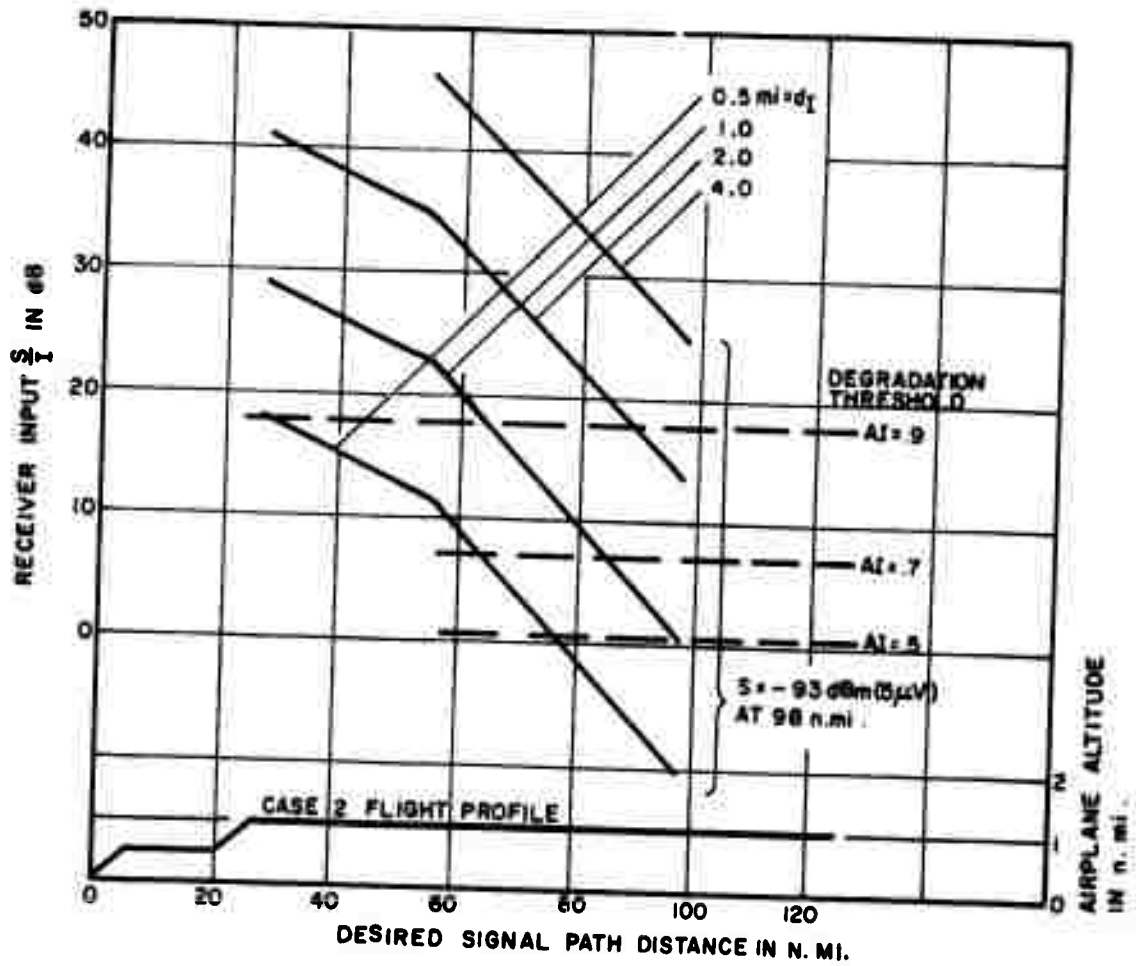

Figure 4-4. Communication Receiver Input Signal-to-Interference Ratios at Various Aircraft Locations for a Family of Interfering Path Distances with a Dielectric Heater Radiating  $10 \mu V/m$  at 5280 feet

*Description of Flight Profiles.* The flight profiles considered are the same as those employed in the dielectric heater interference analysis.

*Determination of Receiver Signal-to-Interference (S/I) Ratio.* Since, at the limit level, the average ERP of the superregenerative receiver is  $-62$  dBm in a  $40$  kHz receiver bandpass and the ERP at the limit of a dielectric heater is  $+15$  dBm, the ERP of the superregenerative receiver is  $15 + 62 = 77$  dB less than the ERP of the dielectric heater. The equations used to determine the input S/I ratio are the right hand sides of Equations 4-2A through 4-2H (used in the dielectric heater analysis)  $+ 77$  dB. For the worst case situation the input S/I ratio is  $-29$  dBm  $+ 77$  dB  $= +48$  dB. This situation occurs at the minimum operational desired signal level input of  $5 \mu\text{V}$ .

*Prevention of Interference.* Since a  $+7$  dB S/I ratio is the threshold for an Articulation Index AI of  $.7$ , and since the worst case S/I ratio produced by a superregenerative receiver is  $+48$  dB, interference will not occur provided the superregenerative receiver conforms to the assumed limits.

#### **Superregenerative Receiver Interference to Ground Receivers**

*Radiation Limit.* The limit of radiation is the same as employed in the analysis of superregenerative receiver interference to airborne receivers.

*Description of Flight Profiles.* The aircraft flight profiles are the same as those employed in the analysis of superregenerative receiver interference to airborne receivers. These profiles determine the desired signal level at the ground receiver.

*Determination of Receiver Signal-to-Interference (S/I) Ratio.* The receiver input S/I for desired path distances ( $d_i$ ) less than  $55$  nautical miles was computed using Equation 4-4.

$$\frac{S}{I} = 106 + 20 \log \frac{d_i}{d_s} \quad (4-4)$$

Equation 4-4 was solved for interfering distances ( $d_i$ ) of  $.001$ ,  $.002$ ,  $.005$ ,  $.01$ ,  $.02$  and  $.04$  nautical miles and the results are plotted in Figure 4-5. The value  $106$  dB is the difference between the desired signal ERP ( $+44$  dBm) and the interfering signal ERP ( $-62$  dBm).

For  $55 < d_s \leq 98$  nautical miles, Figure A-2 of Reference 7 was used to compute the desired level. The interfering signal propagation loss was always assumed to follow the free space equation.

Degradation thresholds of  $AI = .5, .7,$  and  $.9$  are listed on Figure 4-5. Use of the degradation threshold is illustrated by the following example. When the superregenerative receiver is 0.1 mile from the communication receiving antenna an  $AI \leq .7$  (which corresponds to  $S/I \leq 10$  dB) will occur when an aircraft is more than 94 nautical miles away.

*Prevention of Interference.* To prevent the receiver input (S/I) from being less than 10 dB ( $AI = .7$ ) at desired levels of  $-93$  dBm, a distance  $\geq .0133$  nautical miles (80 feet) should be maintained between the superregenerative receiver radiating  $-41$  dBm peak ERP (200 kHz bandwidth) and the ground communication receiving antenna.

## DEGRADATION TO ILS LOCALIZER NAVIGATION SERVICES

### Dielectric Heater Interference to Airborne Receivers

*Radiation Limit.* The dielectric heater radiation limit is the same as that employed in the degradation to communication services analysis.

*Flight Profiles.* The two flight profiles are the same as those employed in the degradation to communication services analysis.

*Determination of Receiver Signal - to - Interference (S/I) Ratio.* The same procedures and constraints that were employed for the determination of ILS/LOC Signal-to-Interference (S/I) ratio were employed for determination of the communication receiver (S/I) ratio. The only change has been modification of the 4-2 family of equations to reflect the higher power (6 dB) of the ground ILS transmitter and the antenna gain (16 dB). For the Case 1 profile the (S/I) ratio is calculated employing the following equations:

$$\frac{S}{I} = 31 \text{ dB}, \frac{1}{2} \leq d_s \leq 5 \text{ nautical miles} \quad (4-5A)$$

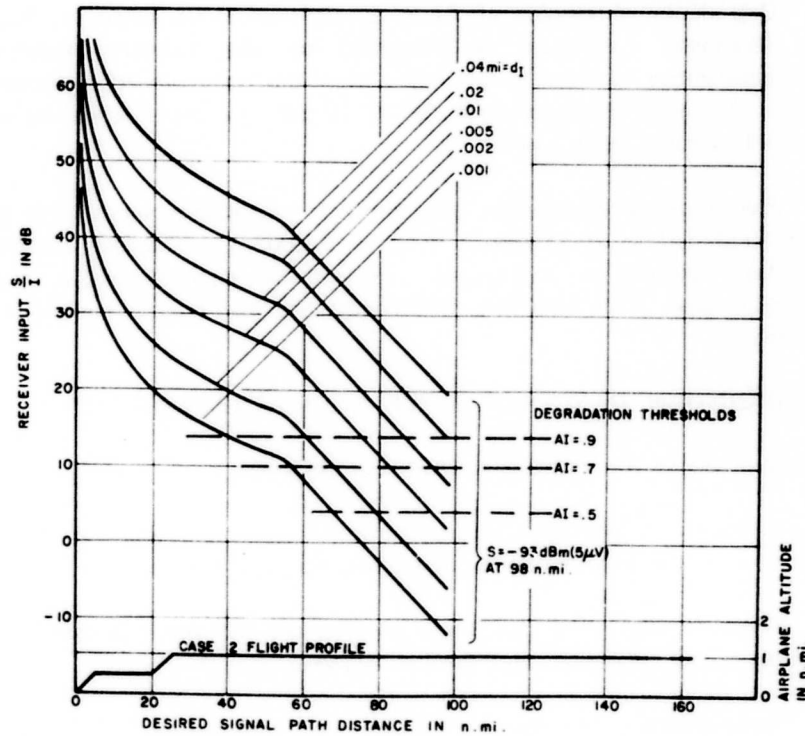

Figure 4-5. Communication Receiver Input Signal-to-Interference Ratios at Various Aircraft Locations for a Family of Interfering Path Distances with a Superregenerative Receiver Interferer Radiating  $50 \mu\text{V}/\text{meter}$  (measured in a 200 kHz Passband at 100 feet)

$$\frac{S}{I} = 35 + \frac{16(20 - d_s)}{15} - 20 \log 2d_s, \quad 5 \leq d_s \leq 20 \text{ nautical miles} \quad (4-5B)$$

$$\frac{S}{I} = 35 + 20 \log \frac{d_s - 14}{12 d_s}, \quad 20 \leq d_s \leq 60 \text{ nautical miles} \quad (4-5C)$$

$$\frac{S}{I} = 35 - 20 \log \frac{d_s}{4}, \quad 60 \leq d_s \leq 125 \text{ nautical miles} \quad (4-5D)$$

Beyond 125 nautical miles the above equations are no longer valid because of the effects of earth curvature. For ranges between 125 and 190 nautical miles, FAA transmission loss curves were employed to determine the S/I ratio (Reference 7, Figure A-5).

The Case 1 flight profile as well as the receiver input signal-to-interference ratios are plotted in Figure 4-6. The degradation threshold for a ½ "dot" deflection of the pilot's indicator is represented by the dashed horizontal line.

For the Case 2 profile the following equations are employed to determine the Signal-to-Interference (S/I) ratio.

$$\frac{S}{I} = 31 \text{ dB}, \quad \frac{1}{2} \leq d_s \leq 5 \text{ nautical miles} \quad (4-5E)$$

$$\frac{S}{I} = 35 + \frac{16(20 - d_s)}{15} - 20 \log 2d_s, \quad 5 \leq d_s \leq 20 \text{ nautical miles} \quad (4-5F)$$

$$\frac{S}{I} = 35 + 20 \log \frac{d_s - 14}{12 d_s}, \quad 20 \leq d_s \leq 26 \text{ nautical miles} \quad (4-5G)$$

$$\frac{S}{I} = 35 - 20 \log d_s, \quad 26 \leq d_s \leq 55 \text{ nautical miles} \quad (4-5H)$$

Beyond 55 nautical miles the above equations are no longer valid because of the effects of the earth's curvature. For ranges between 55 and 106 nautical miles the (S/I) ratio was determined employing the FAA basic transmission loss curves of Reference 7, Figure A-2.

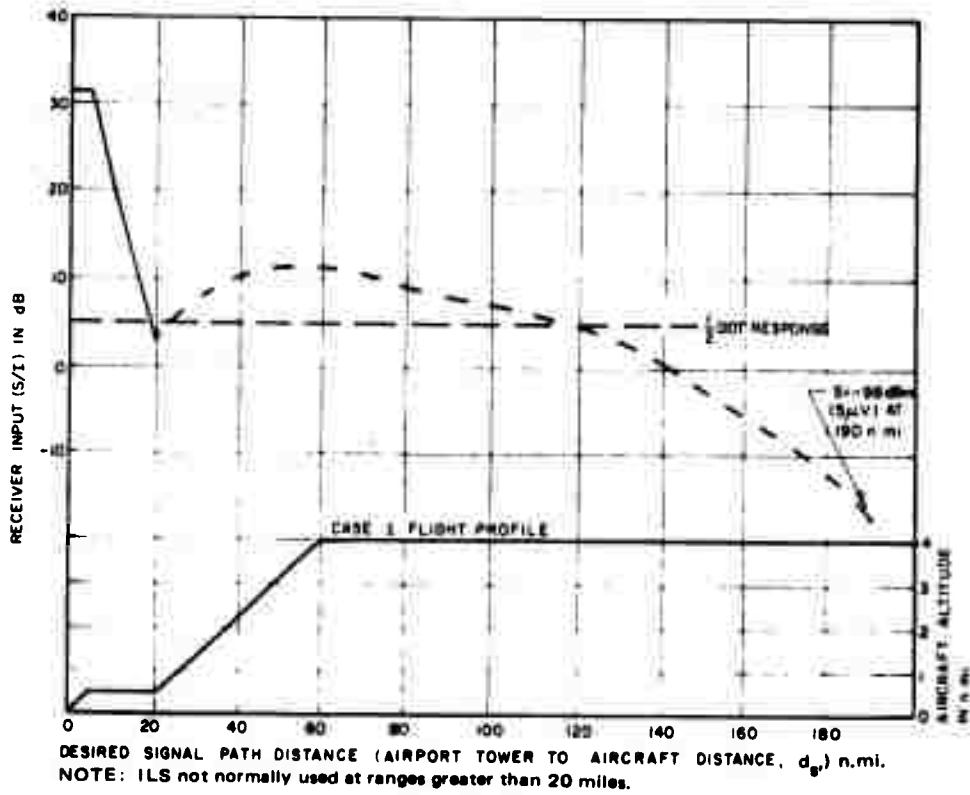

Figure 4-6. ILS Localizer Receiver Input Signal-to-Interference Ratios at Various Aircraft Locations for a Dielectric Heater Radiation of  $10 \mu\text{V}/\text{meter}$  at 5280 feet

The Case 2 profile as well as the receiver input (S/I) ratios are plotted in Figure 4-7. The degradation threshold for a ½ "dot" deflection of the pilot's indicator is represented by the dashed horizontal line.

*Prevention of Interference.* To prevent an indicator deviation of more than ½ "dot" an input (S/I) ratio greater than 5 dB must be maintained. Figure 4-6 shows that the S/I ratio is greater than 5 dB for distances less than 31 nautical miles except for distances between 19 and 23 nautical miles; in this region the S/I ratio drops to 3 dB at 20 nautical miles. If it is desired to protect the localizer service within this range, the dielectric heater radiation limit will have to be decreased by 2 dB. Decreasing the present limit of 10  $\mu\text{V}/\text{m}$  at 5280 feet by 2 dB would result in a figure of 8  $\mu\text{V}/\text{m}$  at 5280 feet. In terms of the limit measured at 100 feet the reduction would be from 84 to 82 dB/ $\mu\text{V}/\text{m}$ .

### **Superregenerative Receiver Interference to Airborne Receivers**

*Radiation Limit.* The superregenerative receiver radiation limit is the same as that employed in the analysis of degradation to communication services.

*Flight Profiles.* The two flight profiles are the same as those employed in the degradation to communication services analysis.

*Determination of Receiver Signal-to-Interference (S/I) Ratio.* At the limit level, the average ERP of the superregenerative receiver is -62 dBm in a 40 kHz receiver bandpass; the ERP, at the limit level, of a dielectric heater is +15 dBm. Therefore, the ERP of the superregenerative receiver is  $15 + 62 = 77$  dB less than the ERP of the dielectric heater. The equations used to determine the input S/I ratio are the right hand side of Equations (4-5A) through (4-5H) (used in the dielectric heater interference analysis) + 77 dB. For the worst case interference situation at 20 miles range, the input S/I ratio is  $+3 \text{ dB} + 77 \text{ dB} = 80 \text{ dB}$ .

*Prevention of Interference.* Since a +5 dB S/I ratio is the threshold for a ½ "dot" indicator response, and since the worst case S/I ratio produced by a superregenerative receiver is +80 dB, interference will not occur.

## **DEGRADATION TO VOR NAVIGATION SERVICES**

### **Dielectric Heater Interference to Airborne Receivers**

*Radiation Limit.* The dielectric heater radiation limit is the same as that employed in the degradation to communication services analysis.

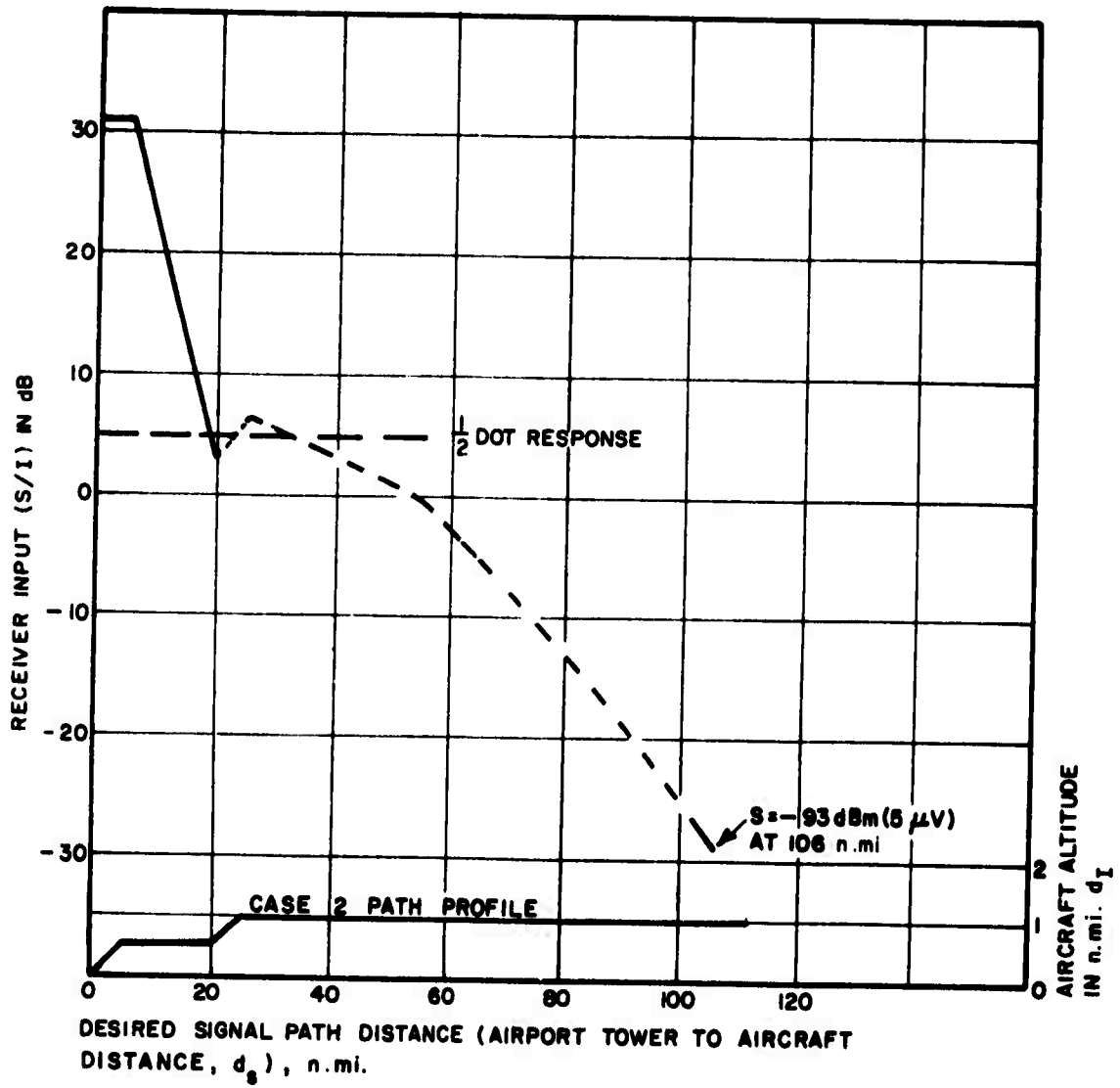

NOTE: ILS not normally used at ranges greater than 20 miles.

Figure 4-7. ILS Localizer Receiver Input Signal-to-Interference Ratio at Various Aircraft Locations for a Dielectric Heater Radiation of 10 μV/meter at 5280 feet

*Flight Profiles.* The two flight profiles are the same as those employed in the degradation to communication services analysis.

*Determination of Receiver Signal-to-Interference (S/I) Ratio.* The same procedures and constraints that were used for the determination of COMM Signal-to-Interference (S/I) ratio were used for the determination of the VOR receiver (S/I) ratio. The only change was the modification of the 4-2 family of equations to reflect the higher power (6 dB) of the ground VOR transmitter.

For the Case 1 profile the (S/I) ratio is calculated employing the following equations:

$$\frac{S}{I} = 15 \text{ dB}, \frac{1}{2} \leq d_s \leq 5 \quad (4-6A)$$

$$\frac{S}{I} = 35 - 20 \log 2d_s, 5 \leq d_s \leq 20 \quad (4-6B)$$

$$\frac{S}{I} = 35 + 20 \log \frac{d_s - 14}{12 d_s}, 20 \leq d_s \leq 60 \quad (4-6C)$$

$$\frac{S}{I} = 35 - 20 \log \frac{d_s}{4}, 60 \leq d_s \leq 125 \quad (4-6D)$$

Beyond 125 nautical miles the above equations are no longer valid because of the effects of earth curvature. For ranges between 125 and 190 nautical miles FAA transmission loss curves were employed to determine the S/I ratio (Reference 7, Figure A-5).

The Case 1 flight profile as well as the receiver input signal-to-interference ratios are plotted in Figure 4-8. The degradation threshold for a one degree deflection of the pilot's indicator is represented by the dashed horizontal line.

For the Case 2 profile the following equations are employed to determine the Signal-to-Interference (S/I) ratio.

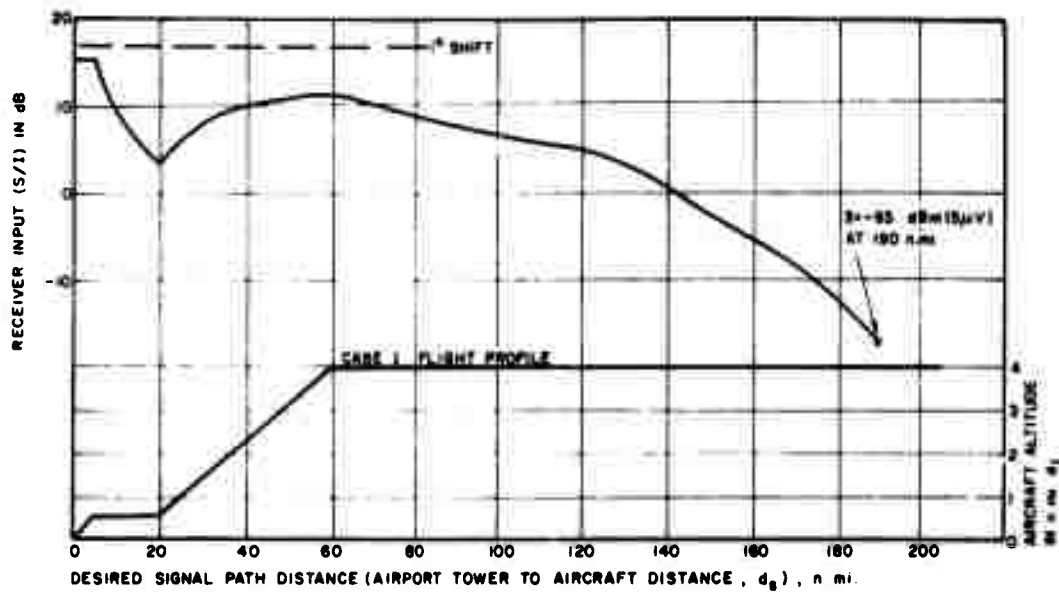

Figure 4-8. VOR Receiver Input Signal-to-Interference Ratio at Various Aircraft Locations for a Dielectric Heater Radiation of  $10 \mu\text{V}/\text{meter}$  at 5280 feet

$$\frac{S}{I} = 15 \text{ dB}, \frac{1}{2} \leq d_s \leq 5 \quad (4-6E)$$

$$\frac{S}{I} = 35 - 20 \log 2d_s, 5 \leq d_s \leq 20 \quad (4-6F)$$

$$\frac{S}{I} = 35 + 20 \log \frac{d_s - 14}{12 d_s}, 20 \leq d_s \leq 26 \quad (4-6G)$$

$$\frac{S}{I} = 35 - 20 \log d_s, 26 \leq d_s \leq 55 \quad (4-6H)$$

Beyond 55 nautical miles the above equations are no longer valid because of the effects of the earth's curvature. For ranges from 55 to 106 nautical miles the (S/I) ratio was determined employing the FAA basic transmission loss curves of Reference 7, Figure A-2.

The Case 2 profile as well as the VOR receiver input S/I ratios are plotted in Figure 4-9. Degradation thresholds for a one-degree shift of the pilot's indicator and a "full flag" are represented by the dashed horizontal lines.

*Prevention of Interference.* To prevent an indicator deviation of more than one degree, an input S/I ratio greater than 17 dB must be maintained. Figure 4-9 shows that the minimum Signal-to-Interference (S/I) ratio of -29 dB occurs when the aircraft is 106 nautical miles away from the VOR ground station. In order to protect the VOR service from interference a  $(17 + 29) = 46$  dB reduction is required in the present limit of  $10 \mu\text{V}/\text{m}$  at 5280 feet. A reduction of 46 dB corresponds to a level of  $0.05 \mu\text{V}/\text{m}$  at 5280 feet. In terms of the limit measured at 100 feet the reduction would be from  $84 \text{ dB}/\mu\text{V}/\text{m}$  to  $38 \text{ dB}/\mu\text{V}/\text{m}$ .

#### **Superregenerative Receiver Interference to Airborne Receivers**

*Radiation Limit.* The Superregenerative receiver radiation limit is the same as that employed in the degradation to communication services analysis.

*Flight Profiles.* The two flight profiles are the same as those employed in the degradation to communication services analysis.

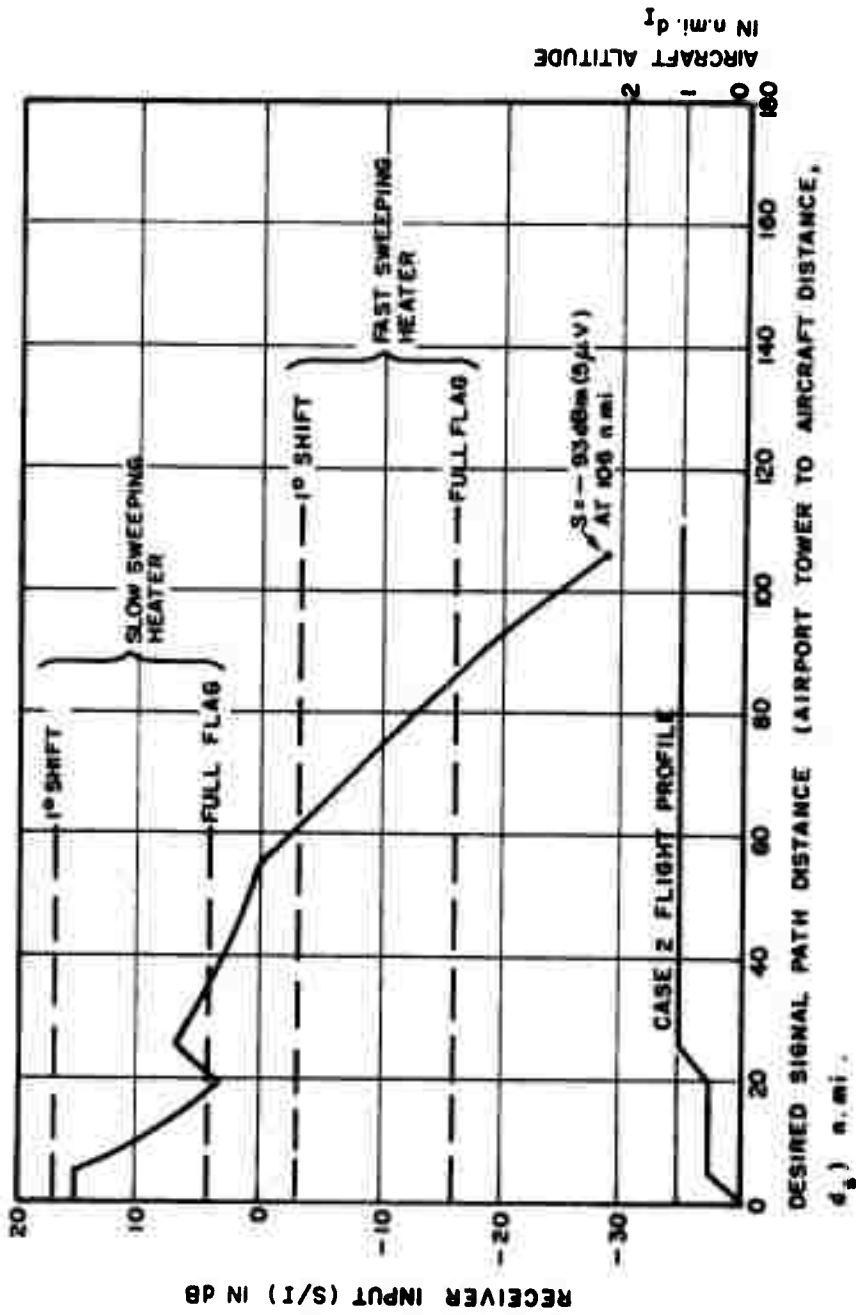

Figure 4-9. VOR Receiver Signal-to-Interference Ratio at Various Aircraft Locations for a Dielectric Heater Radiation of 10 μV/meter at 5280 feet

*Determination of Receiver Signal-to-Interference (S/I) Ratio.* At the limit level, the average ERP of the superregenerative receiver is  $-62$  dBm in a 40 kHz receiver bandpass; the ERP, at the limit level, of a dielectric heater is  $+15$  dBm. Therefore, the ERP of the superregenerative receiver is  $15 + 62 = 77$  dB less than the ERP of the dielectric heater. The equations used to determine the input S/I ratio are the right hand side of Equations (4-6A) through (4-6H) (used in the dielectric heater interference analysis)  $+ 77$  dB. For the worst case interference situation at 106 nautical miles range, the input S/I ratio is  $-29$  dB  $+ 77$  dB =  $48$  dB.

*Prevention of Interference.* Since a  $+17$  dB Signal-to-Interference (S/I) ratio is the threshold for a one-degree indicator response, and since the worst case S/I produced by radiation from the superregenerative receiver is  $+48$  dB, interference will not occur.

#### Summary of Radiation Limits to Prevent Interference

TABLE 4-1 summarizes the conditions necessary to prevent interference to a navigation or communication receiver when the received desired signal level is  $5 \mu\text{V}$ . Interferer radiation levels less than those listed in TABLE 4-1 will cause bearing errors of less than one-degree to VOR navigation receivers, articulation indexes greater than 0.7 to communication receivers and bearing errors much less than "½ dot" to ILS localizer navigation receivers.

The dielectric heater has greater interference potential than the superregenerative receiver, and threatens COMM/NAV services on the ground and in the air. The superregenerative receiver may threaten ground communication services, but will not interfere with COMM/NAV services in the air.

**TABLE 4-1**  
**REQUIRED INTERFERER RADIATION LIMITS**

Interfering Source and Victim Receiver	Radiation limit for Interference Prevention*	Interference Condition
Dielectric heater to airborne receiver (COMM)	48 dB/ $\mu$ V/m at 100 feet or 0.16 $\mu$ V/m at 5280 feet	Interferer directly under aircraft one n. mile high
Dielectric heater to ground receiver (COMM)	84 dB/ $\mu$ V/m at 100 feet or 10 $\mu$ V/m at 5280 feet	Interferer 1.5 n miles from 50 foot high receiving antenna
OR		
	66.5 dB/ $\mu$ V/m at 100 feet or 1.3 $\mu$ V/m at 5280 feet	Interferer ½ n. mile from 50 foot high receiving antenna
Dielectric heater to airborne receiver (ILS/LOC)	82 dB/ $\mu$ V/m at 100 feet or 8 $\mu$ V/m at 5280 feet	Interferer directly under aircraft ½ n. mile high
Dielectric heater to airborne receiver (VOR)	38 dB/ $\mu$ V/m at 100 feet or 0.05 $\mu$ V/m at 5280 feet	Interferer directly under aircraft one n. mile high
Superregenerative receiver to ground receiver (COMM)	50 $\mu$ V/m/200 kHz at 100 feet or -105 dBm/m <sup>2</sup> /kHz at 100 feet	Interferer 80 feet from 50 foot high receiving antenna
Superregenerative receiver to airborne receiver (COMM, ILS/LOC or VOR)	50 $\mu$ V/m/200 kHz at 100 feet or -105 dBm/m <sup>2</sup> /kHz at 100 feet	(No interference)

\* At VHF NAV/COMM Frequencies

**SECTION 5****CONCLUSIONS**

The conclusions derived from this analysis are based on certain conditions and constraints. First, the interfering emitter was always considered to be directly beneath the aircraft in the interference-to-aircraft analysis, and interference emissions were considered to be co-channel in frequency with the desired signal. Second, the criteria used for receiver degradation was an Articulation Index of .7 for communications receivers and either a one-degree or a half-dot indicator shift for navigation receivers. Finally, the suggested modifications to the regulatory limits listed in TABLE 5-1 are for worst case conditions and, if followed, will eliminate any possibility of interference.

Based on the above considerations, it is concluded that:

1. Radiation from dielectric heaters (see Present Limit column, TABLE 5-1) can cause interference to VHF communications and navigation services. Interference will occur if aircraft receivers are operating at the minimum operation desired signal level of five microvolts, and the aircraft is within one nautical mile of the dielectric heater.
2. Potential interference from dielectric heaters will be eliminated if heater emissions are limited to no more than 80 microvolts/meter at a distance of 100 feet as measured on the ground. This marked increase in protection over present regulatory criteria is due to the difference in basic transmission loss between air-to-ground paths and ground-to-ground paths. For example, at 110 MHz and a distance of one statute mile, the ground-to-ground basic transmission loss for a vertically polarized antenna is 116 dB, whereas the ground-to-air loss is only 77 dB.
3. Radiation for superregenerative receivers located on the ground (see Radiation Limit, pg. 4-8) should not cause interference to airborne communication and navigation receivers.
4. Ground VHF communications receivers will not experience interference from superregenerative receivers except at distances less than 80 feet from the receiving antenna.

Interference effects from dielectric heaters and suggested radiation limits necessary to preclude interference are summarized in TABLE 5-1.

**TABLE 5-1**  
**DIELECTRIC HEATER INTERFERENCE**

Receiver	Present Limit	Modified Limit to Prevent Interference at VHF COMM/NAV Frequencies (110 MHz)	Conditions
Airborne Communications	10 $\mu$ V/m at 5280 feet measured on the ground	250 $\mu$ V/m measured at 100 feet on the ground	Worst case-Desired signal level is 5 $\mu$ V, AI = .7. Heater 1 nautical mile away (See Figure 4-3).
ILS Localizer	10 $\mu$ V/m at 5280 feet measured on the ground	12,600 $\mu$ V/m measured at 100 feet on the ground	Worst case-Aircraft 19 to 23 nautical miles from ground station- $\frac{1}{2}$ dot indicator deflection, heater $\frac{1}{2}$ nautical mile away (See Figures 4-6, 4-7).
VOR	10 $\mu$ V/m at 5280 feet measured on the ground	80 $\mu$ V/m measured at 100 feet on the ground	Worst case-Desired signal level is 5 $\mu$ V, 1° indicator deflection-Heater 1 nautical mile away (See Figure 4-9).
Ground Communication	10 $\mu$ V/m at 5280 feet measured on the ground	No Change	No interference except when heater is less than 1.5 nautical miles from ground station, AI = .7, 5 $\mu$ V desired signal level (See Figure 4-4).

## APPENDIX A

### THE RECEIVER WAVEFORM SIMULATION (RWS) MODEL

#### GENERAL

The Receiver Waveform Simulation (RWS) model (Reference 4) was developed to simulate the receiver processing of the input signals. This simulation requires that the input signals (desired and interfering) and noise be sampled in the time or frequency domain. The input signals are combined to form a composite signal at the receiver input. The composite sampled waveform is then modified in accordance with the transfer characteristics of the various receiver stages. The model output is a sampled waveform representing the output of the receiver being modeled.

#### THE RECEIVER

The basic receiver structure involved in the processing of desired and undesired signals is shown in Figure A-1. The receiver signal processing elements include the RF amplifier, mixer, IF amplifier, detector, baseband amplifier, and feedback circuitry. Receiver inputs, in general, consist of a desired signal, interfering signal(s) and noise. The receiver baseband output is a waveform which contains the desired and undesired signals.

The Receiver Waveform Simulation (RWS) model simulates the receiver processing of the input signals. The model is a representation of the significant functions of the receiver signal processing illustrated in Figure A-2, rather than a detailed circuit analysis of each receiver element. The implications of modeling significant receiver functions are examined in the following subsections.

#### RF Amplifier and Mixer

RF amplifier and mixer stages possess nonlinear characteristics that are responsible for the undesirable effects of cross modulation, intermodulation, spurious responses, saturation and desensitization. Co-channel and adjacent channel performance degradation analysis does not usually require consideration of these nonlinear effects. Cross modulation, receiver intermodulation, saturation and desensitization can generally be neglected for RF input (desired and/or undesired) signal levels less than  $-40$  dBm. Spurious responses generally become significant for signal levels greater than  $-40$  dBm.

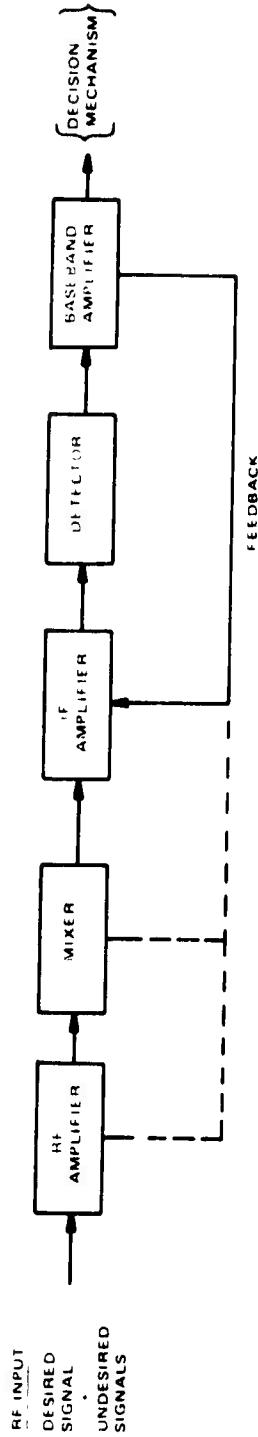

Figure A-1. Basic Receiver Structure

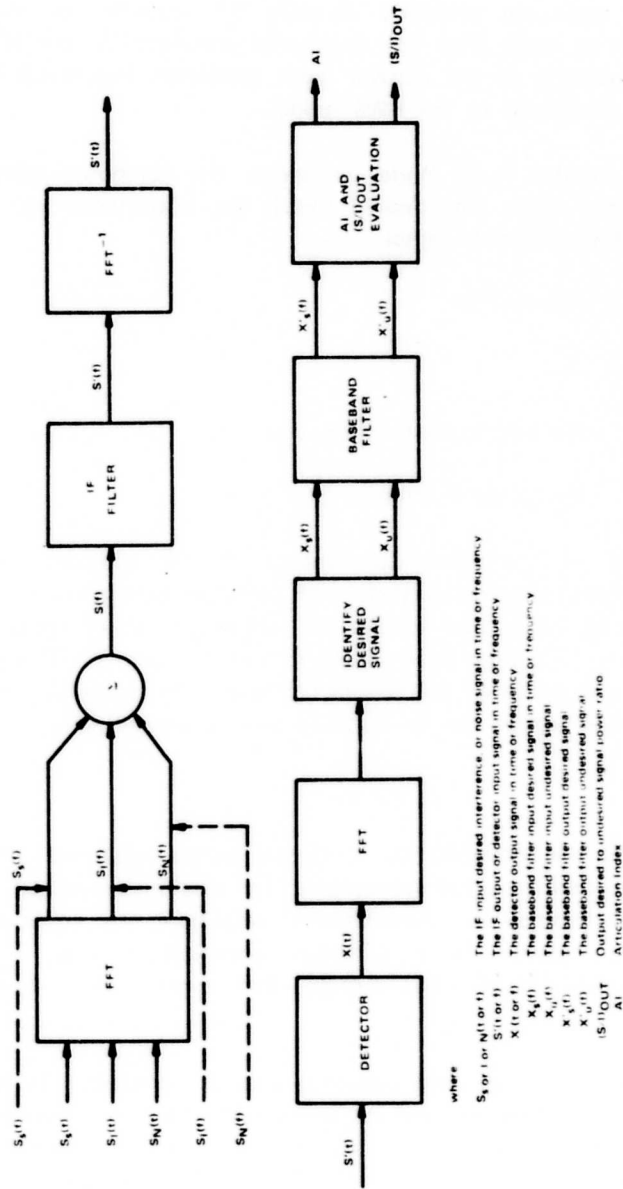

Figure A-2. Computer Simulation Model

where  
 $S_d$  or  $I$  or  $N$  (or  $t$ ) The IF input desired interference or noise signal in time or frequency  
 $S$  (or  $f$ ) The IF output or detector input signal in time or frequency  
 $X$  (or  $f$ ) The detector output signal in time or frequency  
 $X_d$  (or  $f$ ) The baseband filter input desired signal in time or frequency  
 $X_u$  (or  $f$ ) The baseband filter input undesired signal  
 $X'_d$  (or  $f$ ) The baseband filter output desired signal  
 $X'_u$  (or  $f$ ) The baseband filter output undesired signal  
 $(S')/OUT$  Output desired to undesired signal power ratio  
 AI Articulation Index

The RWS model does not presently consider RF amplifier or mixer stage effects. The assumption is made that the composite waveform at the IF input is simply a frequency translation of the receiver input waveform. Figure A-2 shows the receiver stages actually considered in the RWS model.

The input signal to the RWS model represents the composite signal at the input to the IF amplifier stage. The desired signal, the interference and the noise are combined to form the composite signal,

$$V(t) = P(t) \cos \theta(t), \quad (A-1)$$

where,

$P(t)$  = the amplitude function and,

$\theta(t)$  = the phase function

The relative amplitudes of the three components of the composite signal are determined by the Signal-to-Interference (S/I) and Signal-to-Noise (S/N) ratios at the IF input. Any processing losses due to the RF filter and mixer stages must be applied to the RF input (S/I) and (S/N) ratios to convert them to IF input ratios. Spurious responses can be evaluated by the model when the processing loss due to RF pre-selection and mixer action can be obtained from measured data.

### IF Amplifier

IF amplifier stages are designed to eliminate signals that are not in the frequency range of the desired signal bandwidth. To obtain the desired degree of selectivity, cascaded single-tuned or double-tuned amplifiers are commonly used. Double-tuned amplifiers provide more constant amplification over a band of frequencies and attenuate frequencies outside this band more sharply than single-tuned amplifiers.

The IF amplifier linear transfer characteristics can be considered in terms of a frequency-independent gain function and a normalized frequency-dependent filter function. Since only relative desired and undesired signal levels are needed, only the frequency-dependent filter function is required in the RWS model. The n-stage, double-tuned filter amplitude and phase characteristics are modeled.

The composite signal, after being band-limited by the IF filter, is processed by the detector stage. The signal has been delayed in time by the IF filter and, in general, can be represented by an amplitude and angle modulated carrier. For modeling purposes, the carrier frequency can, without loss of generality, be assigned the value of the center frequency of the IF filter. The composite signal at this point can be expressed as,

$$V'(t) = AP(t-t'_o)\cos[2\pi f_o t + \theta(t-t'_o)] \quad (\text{A-2})$$

where,

and The prime indicates modification by the filter

- $f_o$  = the IF center frequency
- $t'_o$  = the time delay of the filter
- $\theta$  = the phase function relative to  $f_o$ ,
- $A$  = a constant, and
- $P$  = the normalized amplitude function.

### Detector

The detector stage separates the modulation from the carrier and transforms this modulation to a baseband waveform. The detection process used depends on the type of system being analyzed. The detection processes that have been incorporated into the RWS model are amplitude, phase, frequency, single sideband and frequency division multiplex detection.

The amplitude detection process extracts the amplitude variations from the composite waveform in Equation A-2. A typical detector is designed with a time constant which permits accurate reproduction of the slowly varying envelope of the waveform but disregards the high frequency carrier. For modeling purposes, an ideal envelope detection process will be assumed; that is, one that reproduces the envelope undistorted, with no trace of the carrier remaining. This ideal detector is satisfactory when the envelope of the composite signal has a bandwidth which is small relative to the IF center frequency (this is true for most practical systems).

### **Baseband Amplifier**

Baseband filtering is employed in receivers to eliminate undesired signals in frequency ranges outside the desired baseband signal bandwidth. These undesired signals result from interference and/or noise processed through the receiver with the desired signal, and from distortion introduced by the receiver stages themselves. Only the normalized frequency-dependent filter characteristics of the baseband amplifier are required in the RWS model. The rationale for this is the same as that explained for the IF amplifier modeling.

### **Feedback Circuitry**

Feedback circuitry can be grouped into two categories. The first category is designed to maintain a constant signal level. These circuits are generally classified as Automatic Gain Control (AGC) or Automatic Volume Control (AVC). The second basic type is employed in synchronized phase or frequency detection circuitry. The simulated time waveform modeling of either of these categories of feedback is actually not required in most compatibility analysis problems. At this time, these feedback effects are not simulated in the RWS model.

For the common AGC case, it can be shown from analysis and measurements that the AGC has no appreciable degradation effect unless the performance of the communication system has been substantially reduced. This does not hold for certain receivers, such as TACAN, which involve digital signal processing wherein the automatic control of the signal level is an integral part of the signal processing. The RWS model, therefore, requires the additional modeling of AGC/AVC feedback effects only for low performance levels or for simulating receivers with special signal processing.

### **Decision Mechanism**

The baseband output signal contains the desired and undesired signals. The undesired signal results from interference and/or noise processed through the receiver with the desired signal, and from distortion introduced by the receiver stages. The output waveform of the model represents the receiver system output waveform and can be expressed as a time waveform or a frequency function.

Articulation Index (AI) is a comprehensive measure of performance for voice communication systems. AI and the desired to undesired power ratio are calculated at the output of the RWS model. Each of these methods requires that the output desired signal be identified and separated from the total audio output. This is accomplished in the model by comparing the receiver output when only an input desired signal is used, with the output for the case of desired signal plus interference and noise at the input.

## MODELING TECHNIQUES

The modeling approach incorporating equivalent low-pass analysis and the Fast Fourier Transform algorithm is illustrated in the summarized flow chart in Figure A-3.

Equivalent low-pass analysis, often used in analytic solutions and representations of system characteristics, is used throughout the RWS model. The entire problem can be solved or modeled without the radio frequency carrier being present, thus allowing computations that consider only the modulating frequencies.

The functional approach to receiver simulation modeling on a digital computer is presently feasible because of the Fast Fourier Transform (FFT) algorithm. The FFT allows efficient transformation between the time and frequency domains and facilitates the linear and nonlinear processing of the signal.

Simulating the receiving system on a digital computer has several advantages. Attempting to analyze the system becomes very difficult when a nonlinear operation such as detection must be considered. Only special cases have been approximated adequately to provide useful equations for system performance evaluation. The digital computer provides the advantages of rapid solution to complex problems, stability of applied parameter values and relationships, and repeatability of results. There are, of course, limitations imposed by the size of the immediate access storage and by the Central Processing Unit (CPU) time required to process one set of parameters. The computer word length limits the accuracy of results; however, single precision word length has been found to be adequate. Most problems of interest can be processed within the 64,000 word core of the UNIVAC 1108 computer at ECAC. The CPU time per data point depends on the number of input samples and may run as high as 30 seconds for the maximum number of samples.

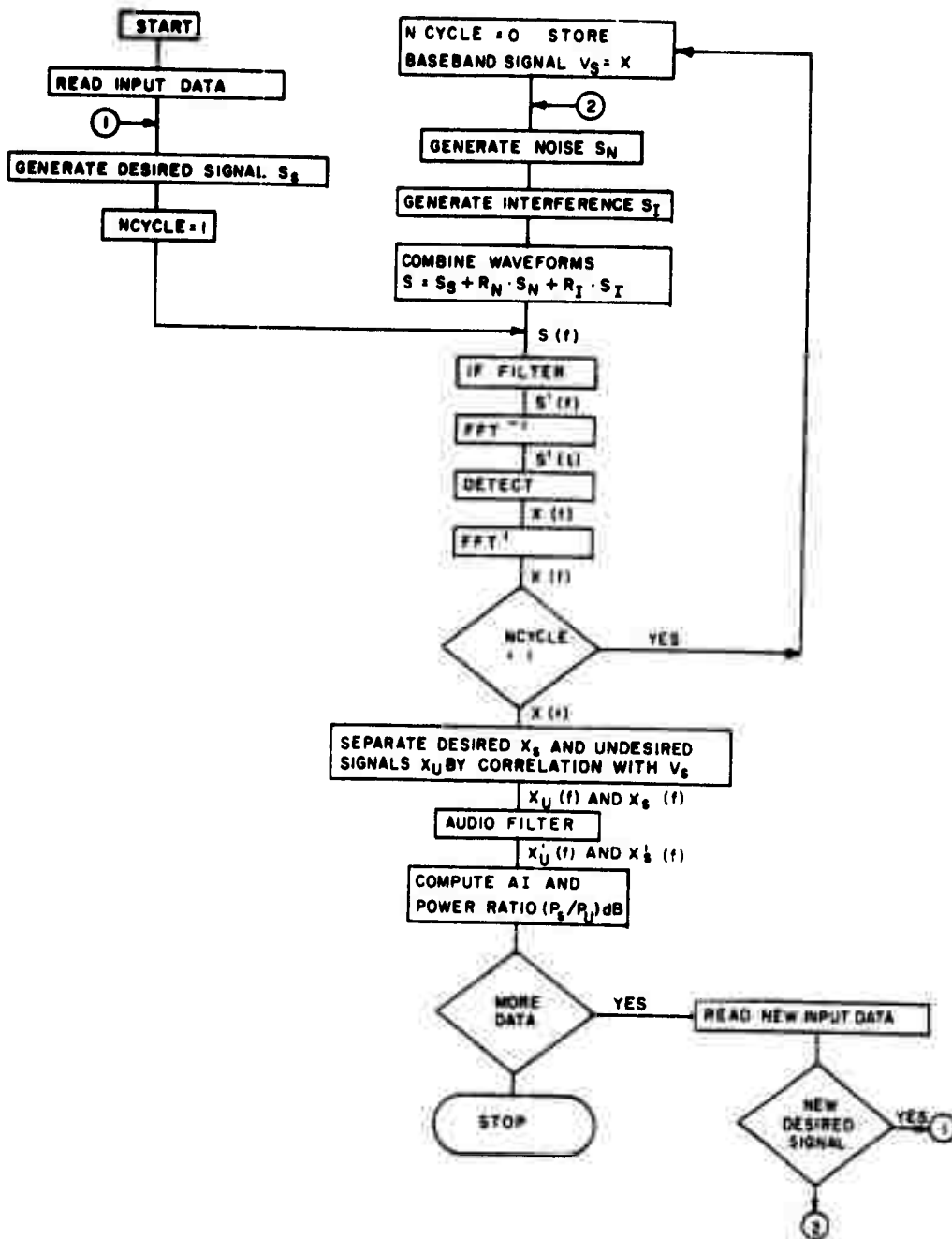

Figure A-3. Receiver Waveform Simulation (RWS) Block Diagram

Most RWS model processing, including filtering, is performed in the frequency domain. It is necessary for the detection process to have the composite signal time waveform available. Therefore, both the direct and inverse Fourier transforms are needed in the model. On a digital computer, these Fourier transformations must be of the discrete type and are very time consuming when large numbers of sample points are to be transformed. The Fast Fourier Transform (FFT), used in the RWS model, greatly reduces the time required to perform the discrete Fourier transforms. Using the FFT algorithm to calculate discrete Fourier transforms allows rapid conversion between the time and frequency domains and permits modeling of each stage of the receiving system in the most convenient domain.

## COMPUTER MODEL

The sequence of operations performed by the RWS model is summarized in Figure A-3. First, input data are read into the computer, including system parameters, waveform parameters, and control statements used during execution of the program. Input waveforms are then generated and combined to form the composite signal at the model input, the IF stage. On the first cycle through the model, only the desired signal is processed. The detector output is assumed to be the desired output signal; it is stored and used in a correlation process to extract the desired signal from the total detector output when combined input signals are processed. Filtering is applied to the desired and undesired baseband frequency functions separately. The desired and undesired baseband power are obtained and used to calculate the output signal-to-interference power ratio, expressed in decibels. The Articulation index is calculated next, if this option has been selected for a voice desired signal. The program then recycles, using input data for another set of operating conditions, and terminates when no more data are present. Results are printed in summary form at the end of each pass through the receiver model. Detailed frequency functions and/or time waveforms can be printed at various stages throughout the processing. Control of the cycling and printouts is accomplished by the data card sequence and control cards inserted between data cards.

## INPUTS AND OUTPUTS

Input parameters describe the receiver and signal characteristics. For the receiver they include the type of detection process and desired signal, the number of double-tuned IF filter stages, the IF bandwidth, the number of baseband high and low pass filter stages and the baseband low, high, and de-emphasis 3 dB frequencies. Other input parameters describe the interference and determine the input signal-to-noise and signal-to-interference power ratios.

The output consists of a one page summary of the input data, the output desired-to-undesired signal power ratio and the Articulation Index. In addition, time waveforms/frequency functions at any stage of the signal processing can be printed out in tabular form and/or plotted on a CALCOMP plotter.

### LIMITATIONS

The RWS model does not include RF and mixer non-linear effects or feedback. The digital computer requires that functions be represented as discrete point functions with finite sample sizes. The UNIVAC 1108 Computer configuration at ECAC limits the practical sample size to  $2^{13} = 8192$  complex points. Therefore, all signals must be band-limited in order to be exactly represented in the frequency domain by a truncated Fourier series of 4096 frequency components. Random signals can be only approximately represented by using band-limited periodic functions.

### NAV/COMM RECEIVER RESULTS

The RWS model was used to determine the (S/I) input vs. the S/(N + I) output characteristics of a communication, VOR and ILS localizer receiver. Receiver input signal to noise ratios of 20 dB and 66 dB were used. The interfering source was a simulated dielectric heater signal.

Communication receiver results are shown in Figures A-4 through A-15. Note the measured data comparison on Figure A-9. VOR receiver results are shown in Figures A-16 through A-21. Localizer receiver results are shown in Figure 3-13. The  $\Delta$ 's shown in Figures A-4 through A-21 refer to fixed offsets for dielectric heater interfering frequencies, rather than to dielectric heater sweep rates.

NAV/COMM receiver results with a superregenerative receiver interferer are shown in Figures 3-8, 3-9, 3-14 and 3-18.

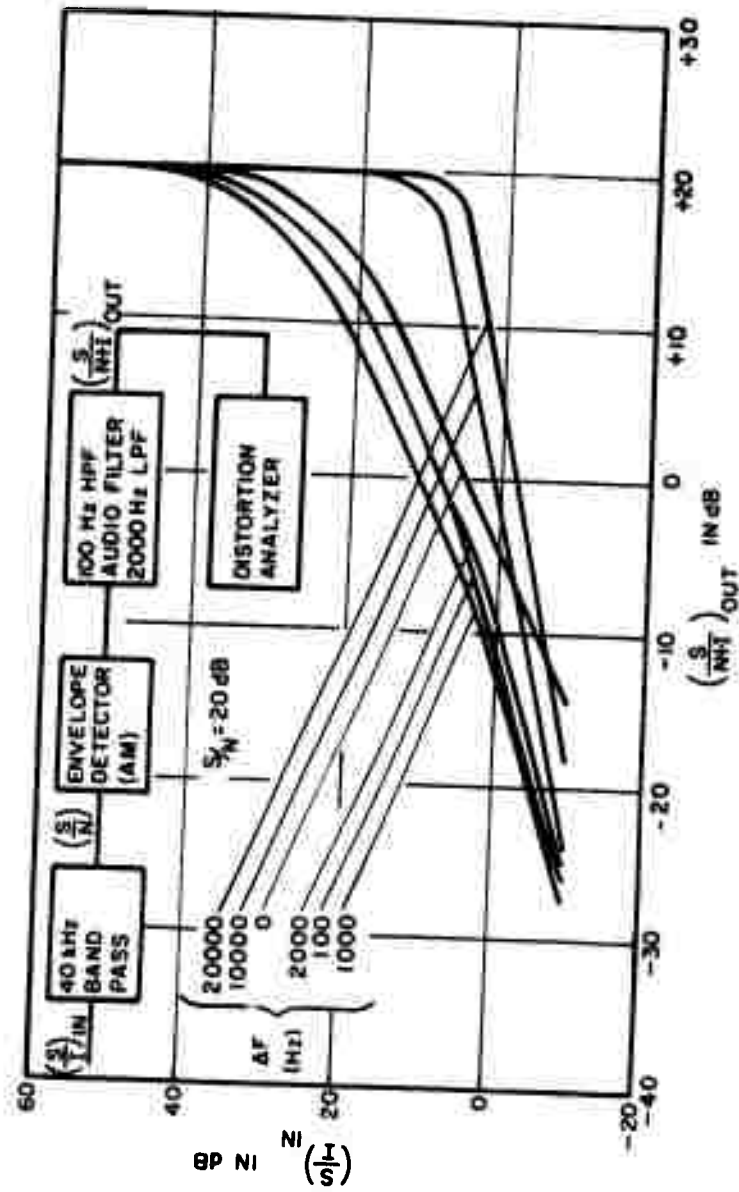

Figure A-4. Analytical Degradation to a Communication Receiver from a Single-Phase, Full-Wave Dielectric Heater

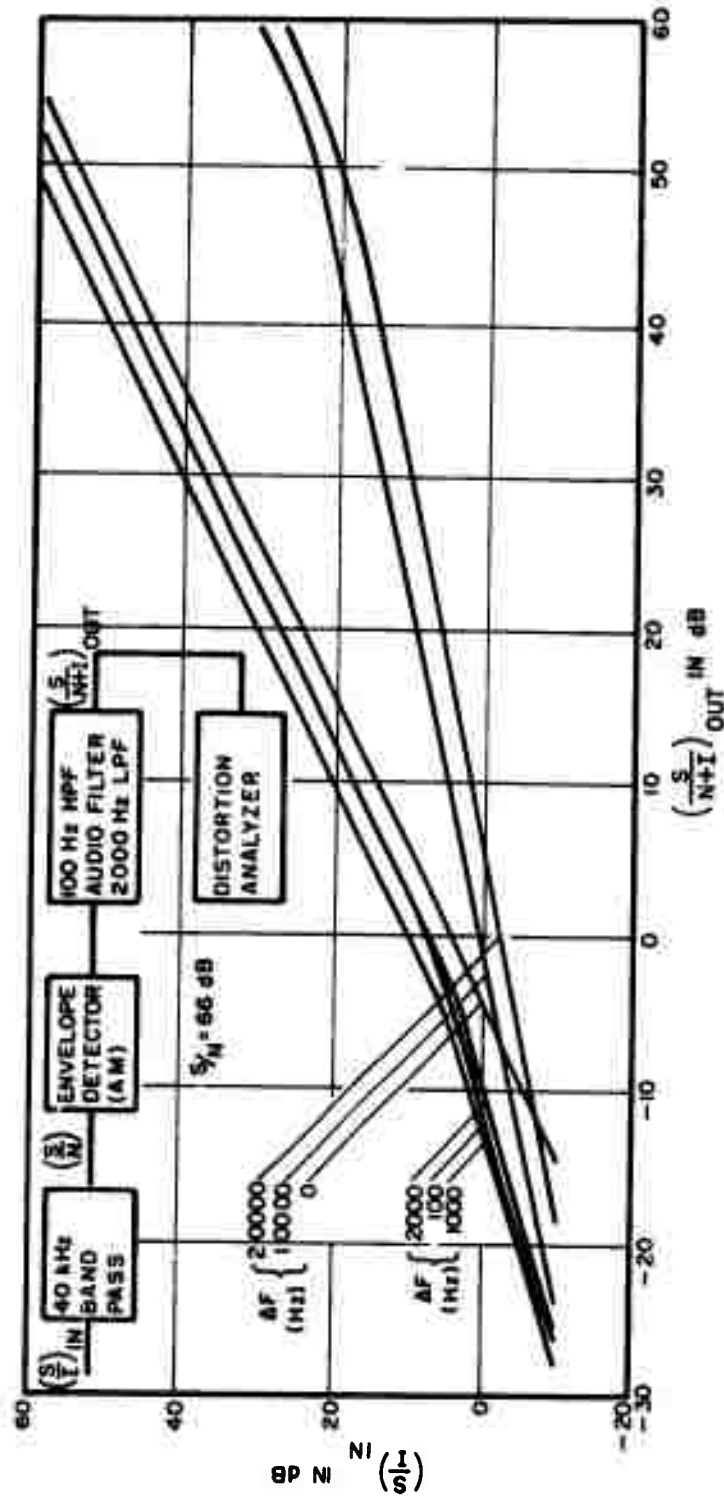

Figure A-5. Analytical Degradation to a Communication Receiver from a Single-Phase, Full-Wave Dielectric Heater

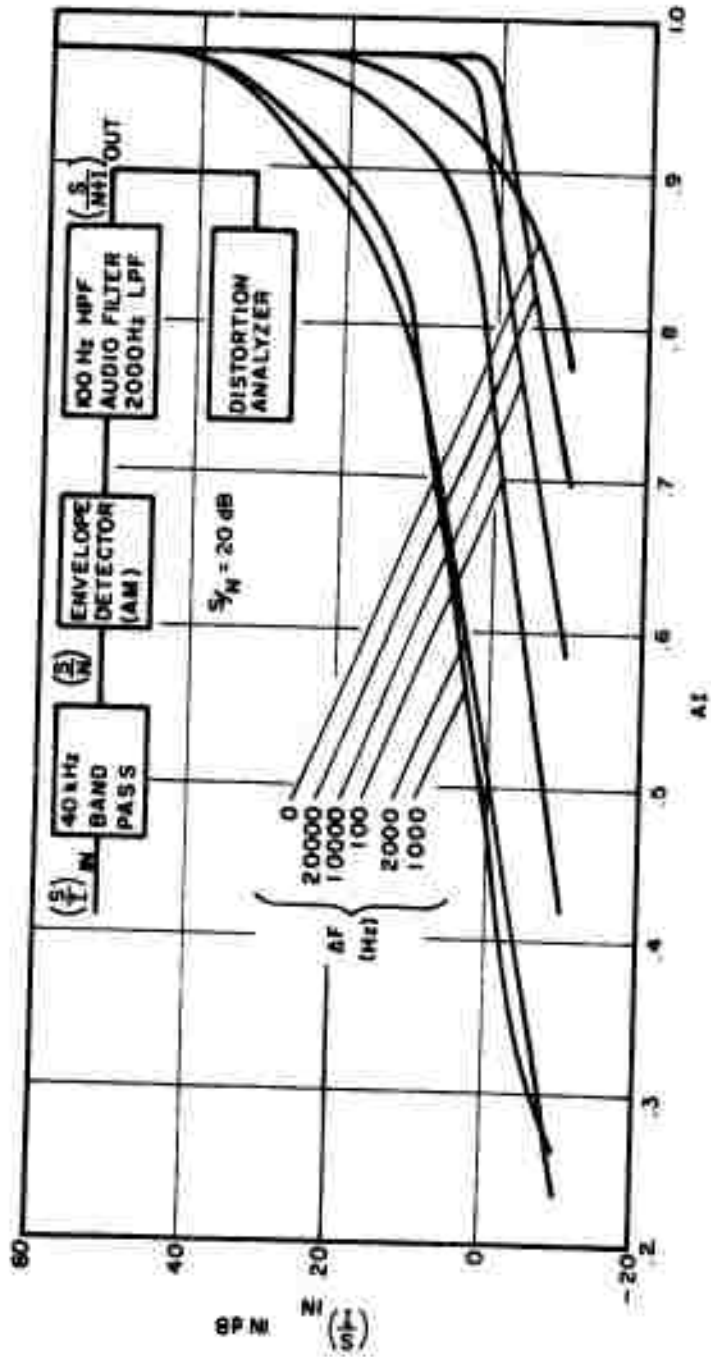

Figure A-6. Analytical Degradation to a Communication Receiver from a Single-Phase, Full-Wave Dielectric Heater



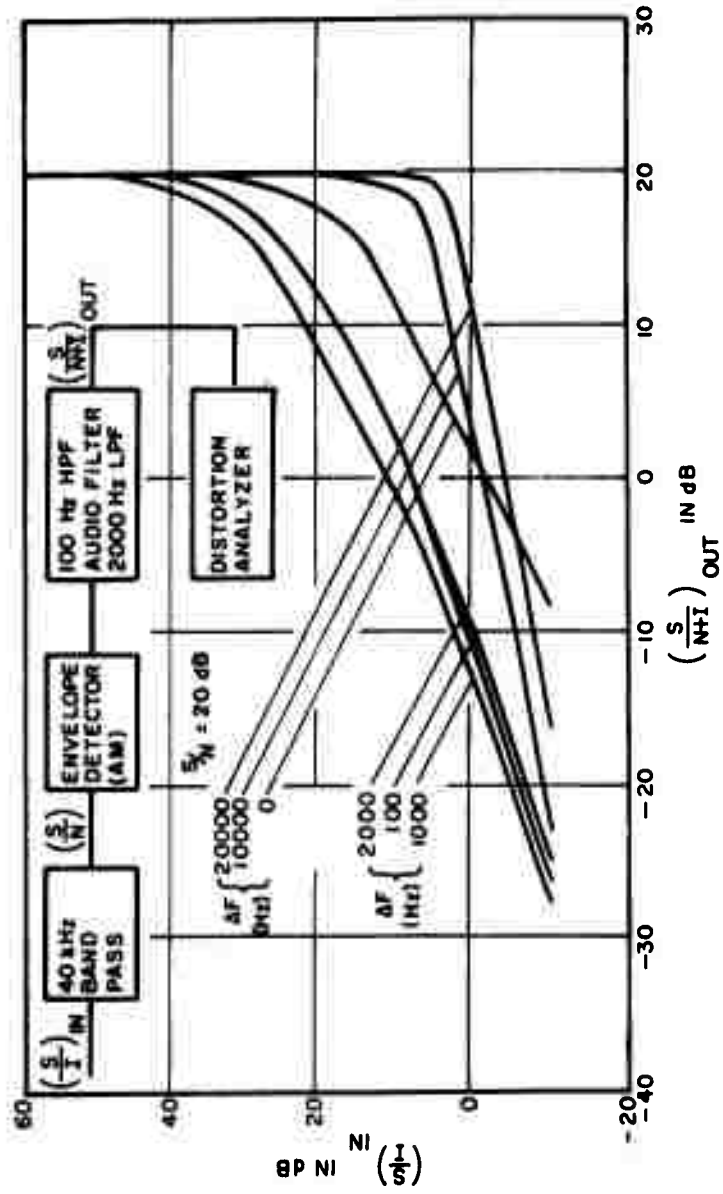

Figure A-8. Analytical Degradation to a Communication Receiver from a 3-Phase, Half-Wave Dielectric Heater

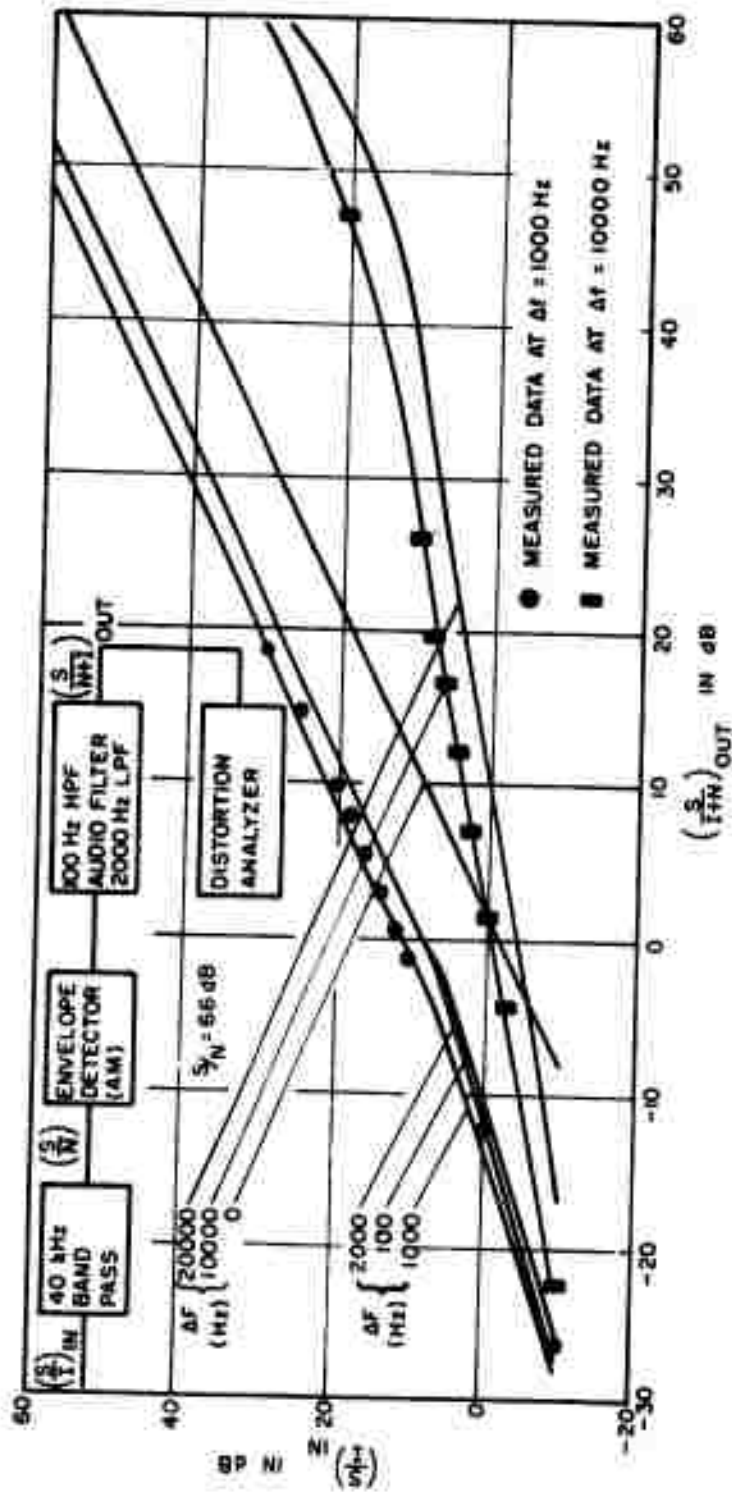

Figure A-9. Analytical Degradation to a Communication Receiver from a 3-Phase, Half-Wave Dielectric Heater

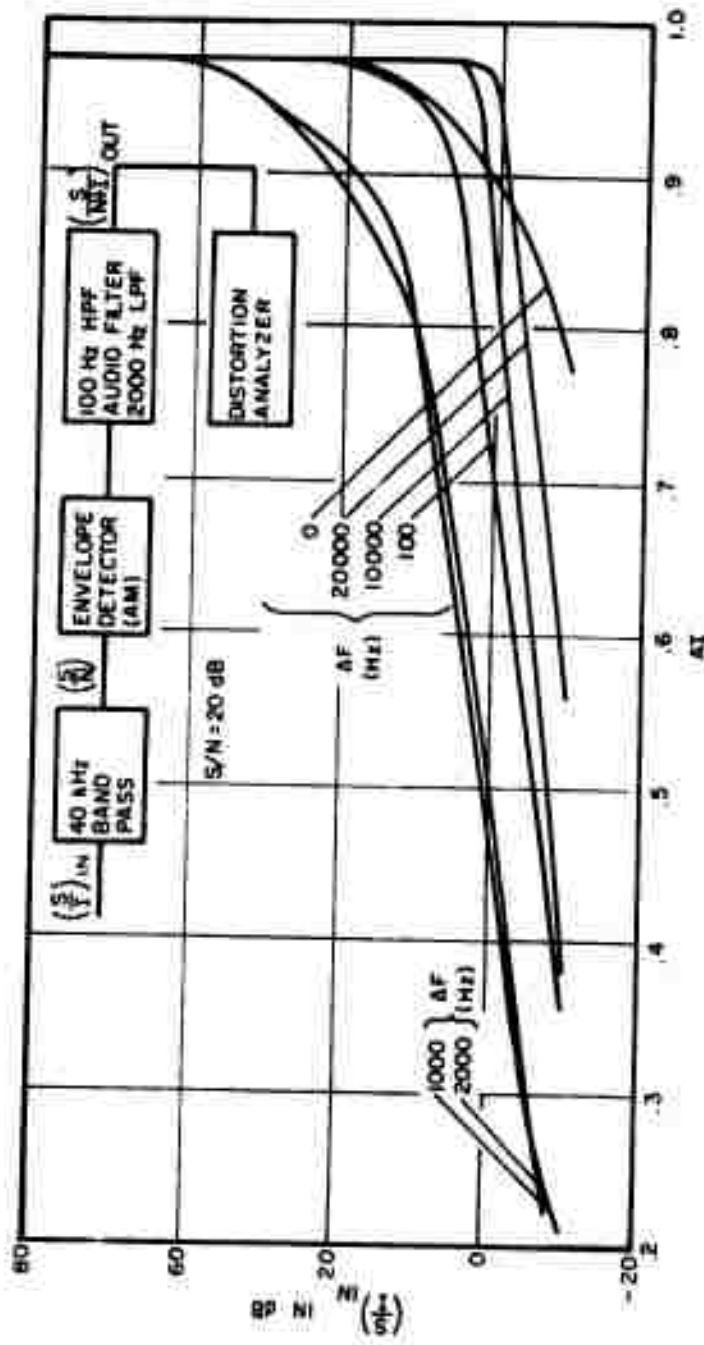

Figure A-10. Analytical Degradation to a Communication Receiver from a 3-Phase, Half-Wave Dielectric Heater

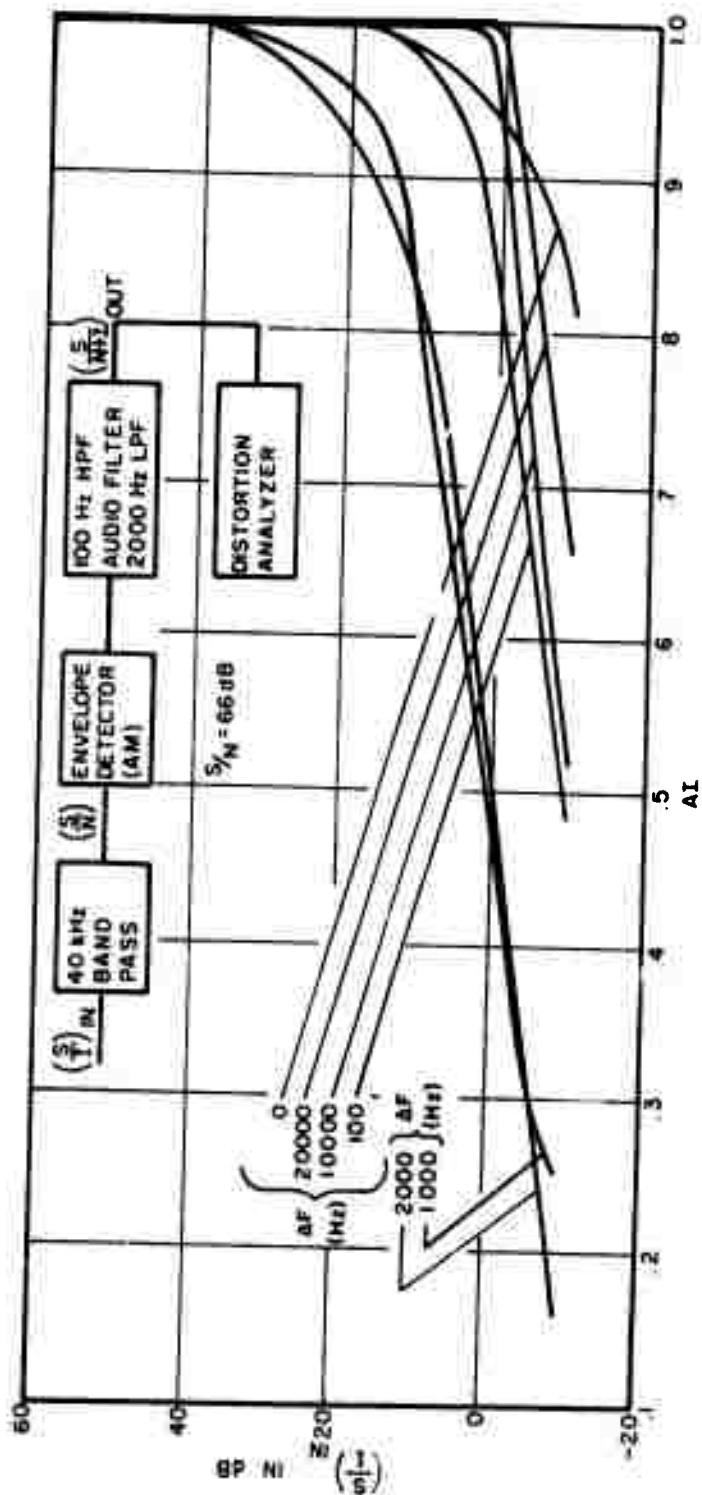

Figure A-11. Analytical Degradation to a Communication Receiver from a 3-Phase, Half-Wave Dielectric Heater

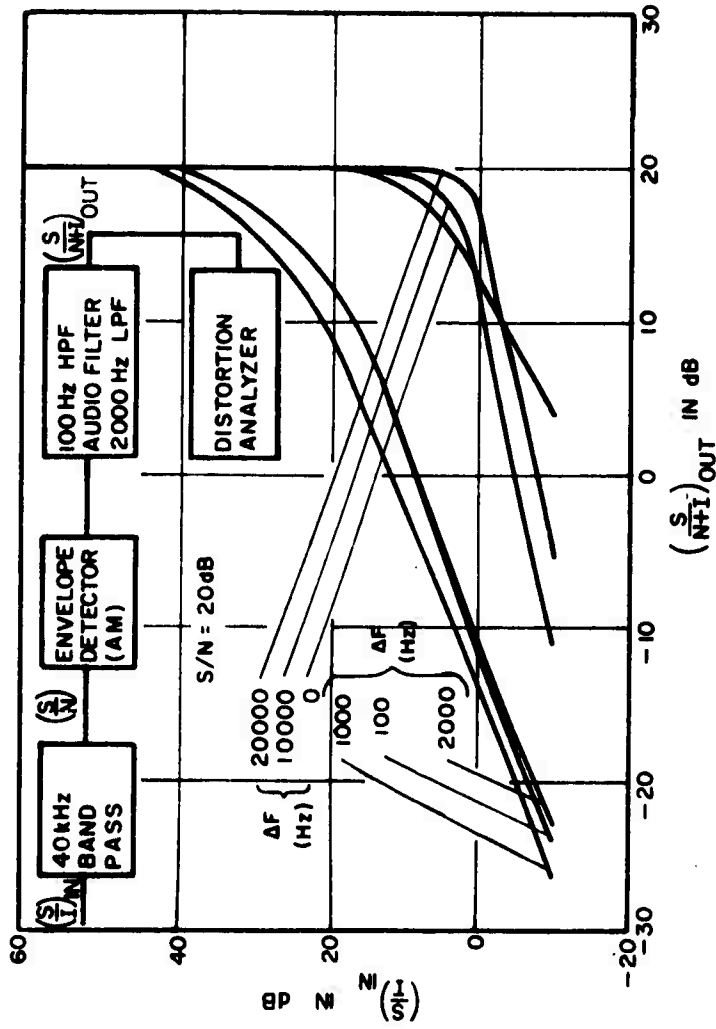

Figure A-12. Analytical Degradation to a Communication Receiver from a 3-Phase, Full-Wave Dielectric Heater

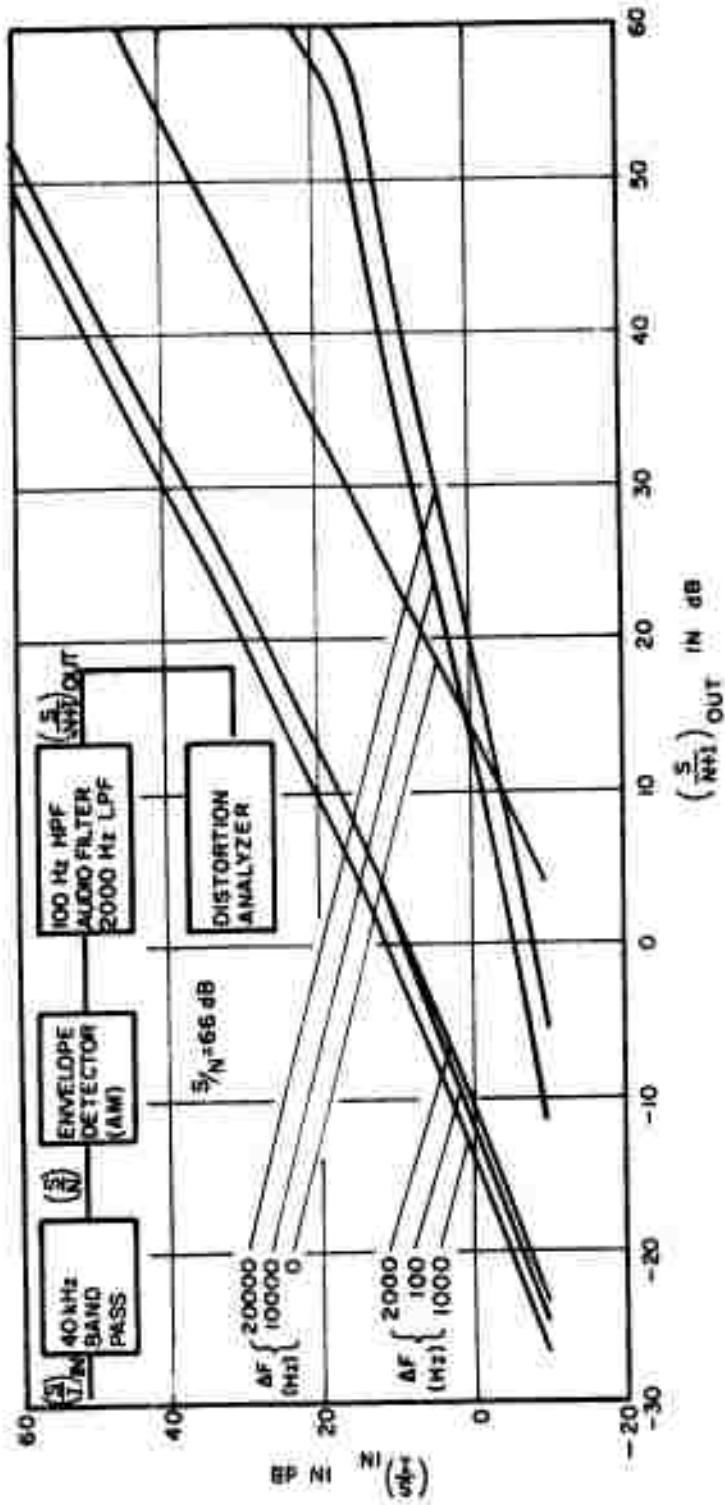

Figure A-13. Analytical Degradation to a Communication Receiver from a 3-Phase, Full-Wave Dielectric Heater

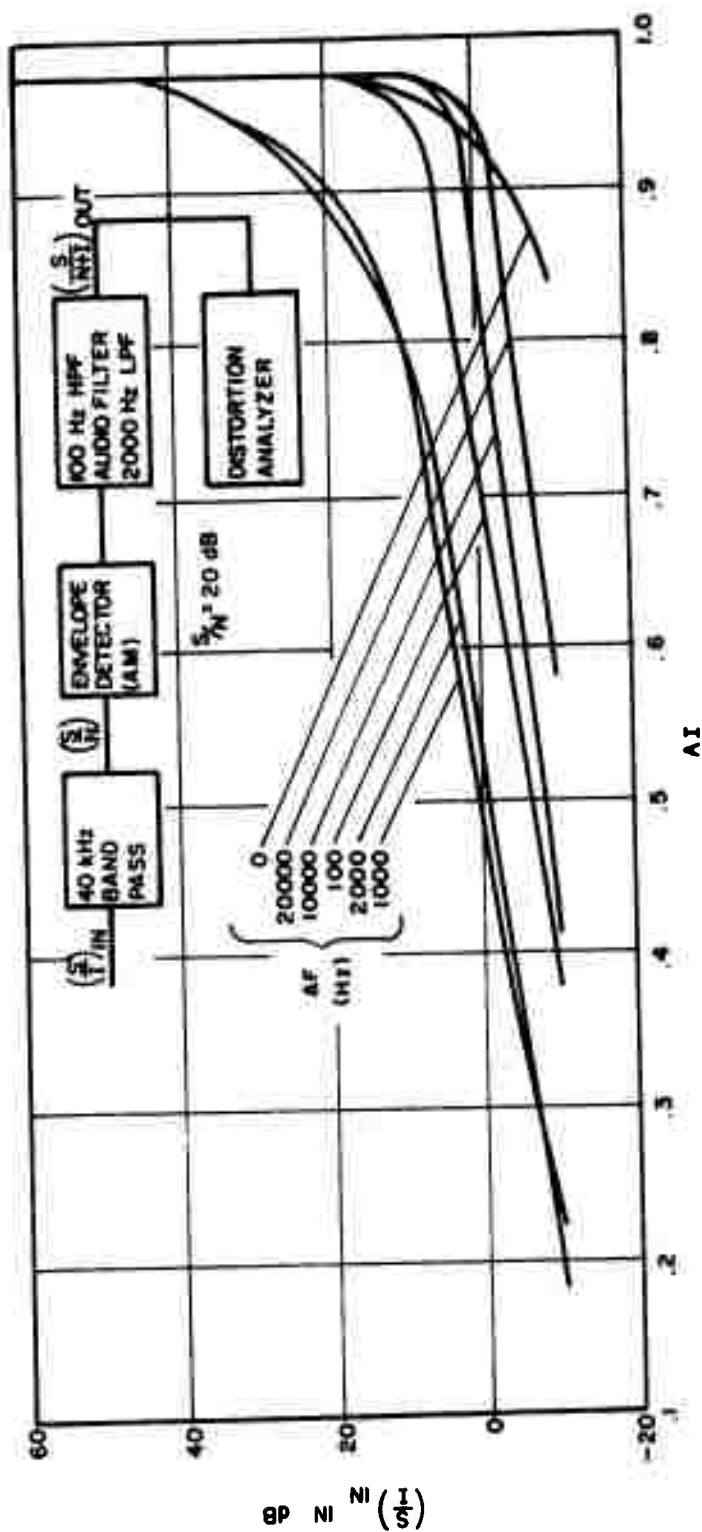

Figure A-14. Analytical Degradation to a Communication Receiver from a 3-Phase, Full-Wave Dielectric Heater

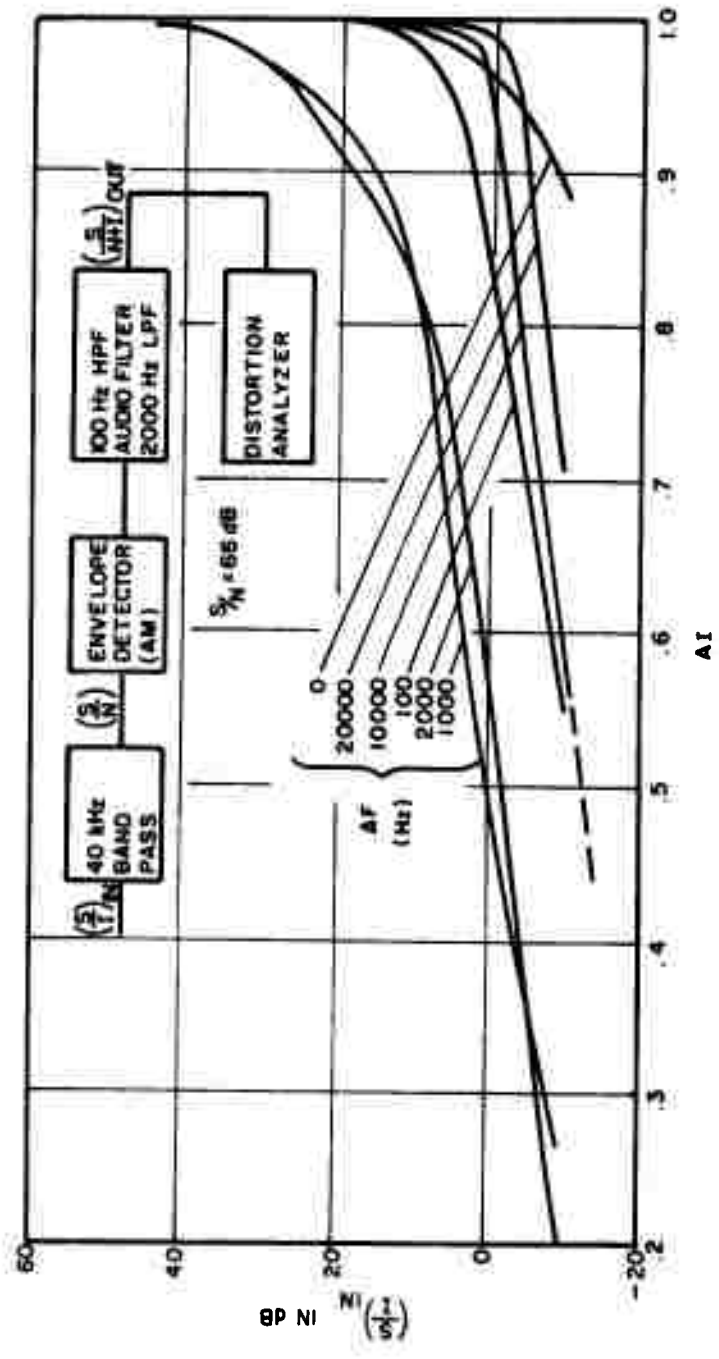

Figure A-15. Analytical Degradation to a Communication Receiver from a 3-Phase, Full-Wave Dielectric Heater

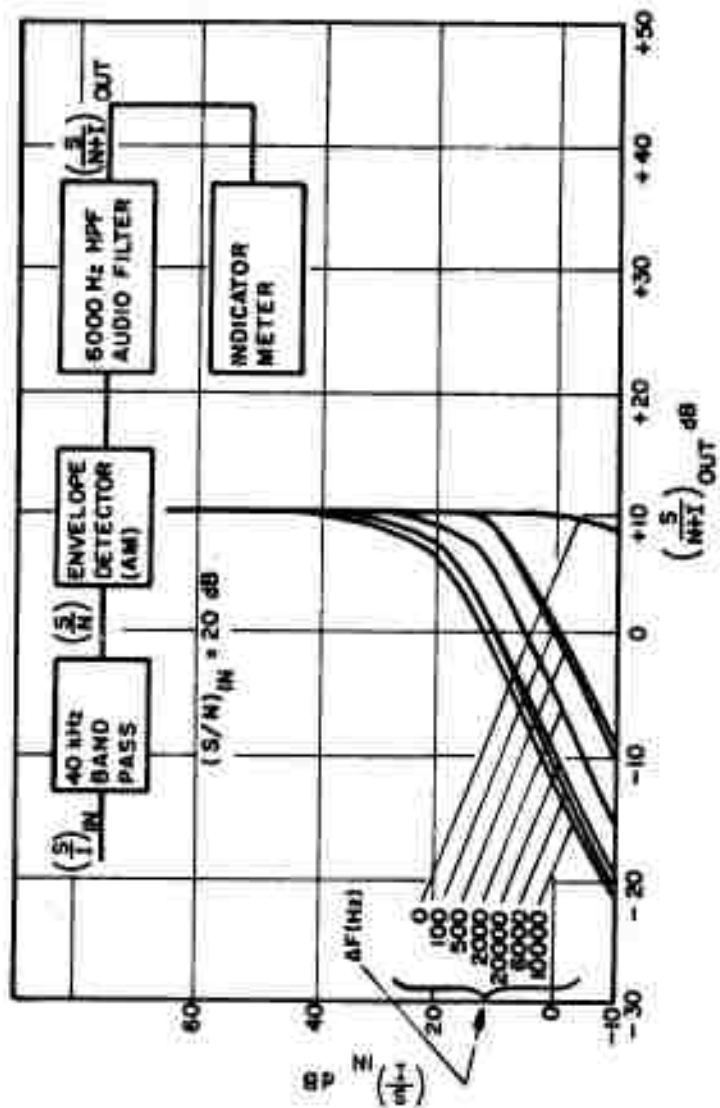

Figure A-16. Analytical Degradation to a VOR Navigation Receiver from a 1-Phase, Full-Wave Dielectric Heater

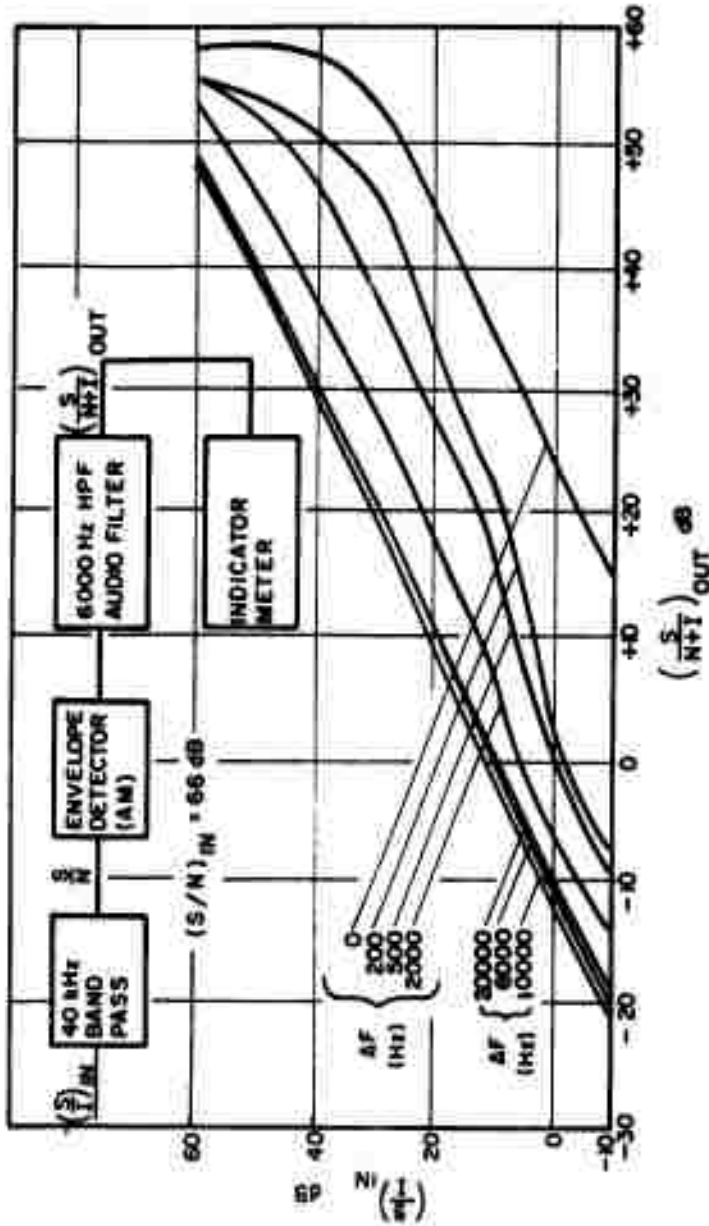

Figure A-17. Analytical Degradation to a VOR Navigation Receiver from a 1-Phase, Full-Wave Dielectric Heater

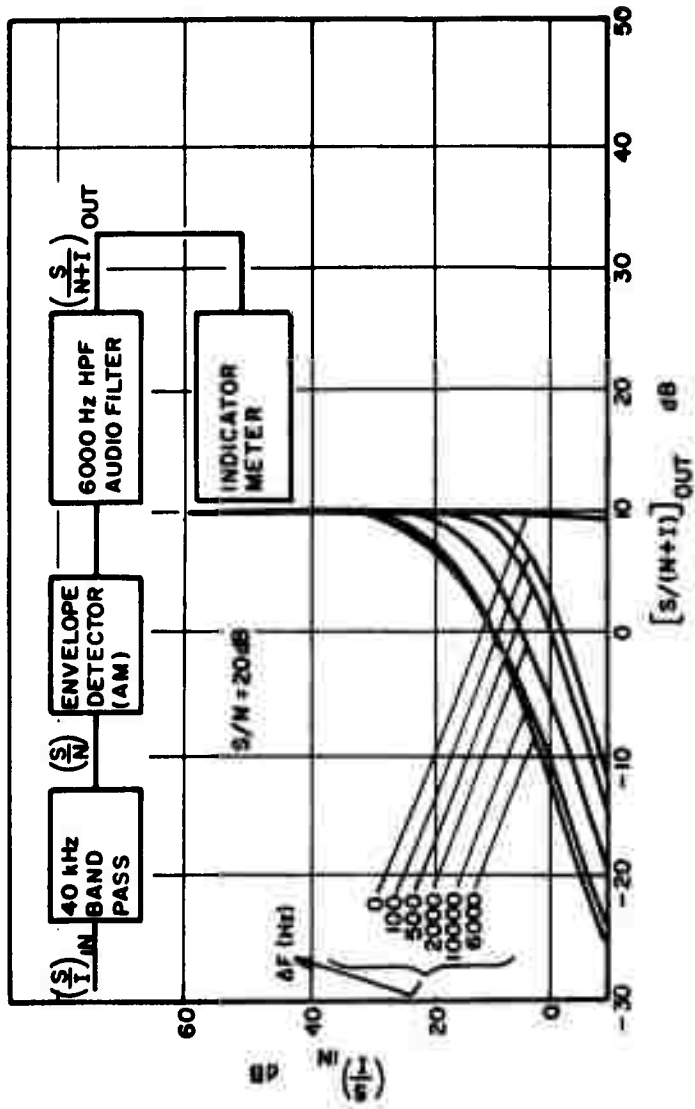

Figure A-18. Analytical Degradation to a VOR Navigation Receiver from a 3-Phase, Half-Wave Dielectric Heater

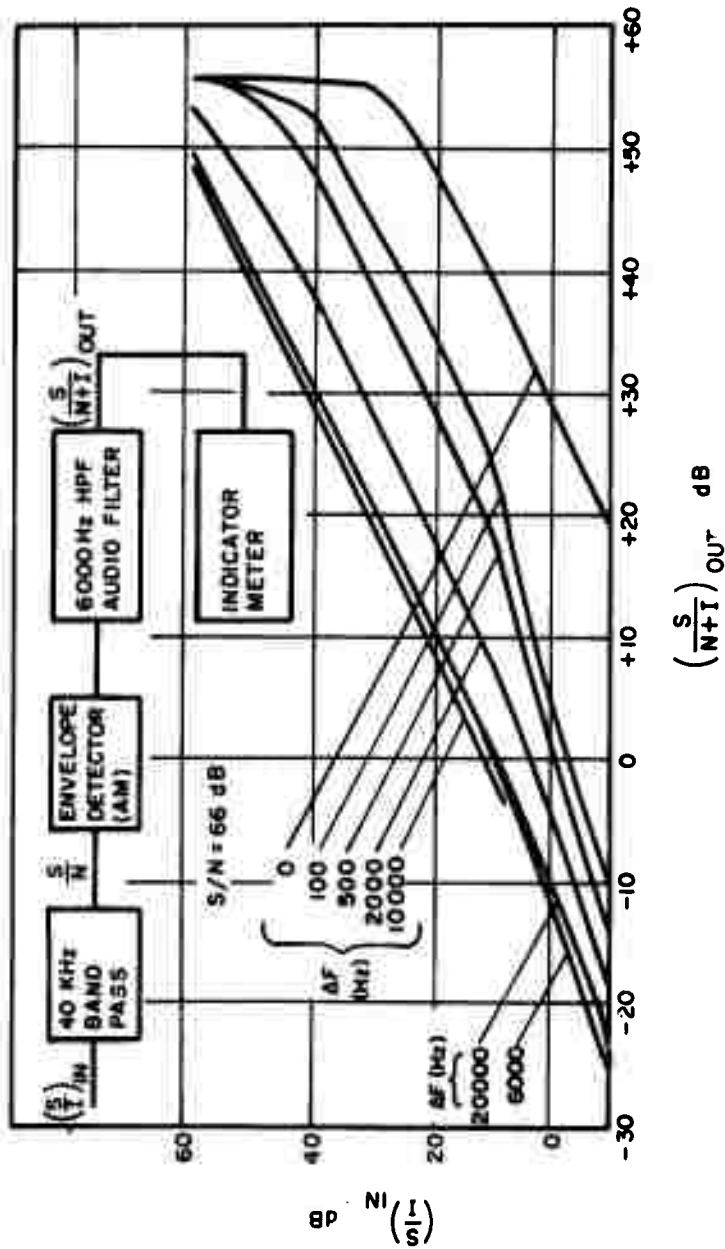

Figure A-19. Analytical Degradation to a VOR Navigation Receiver from a 3-Phase, Half-Wave Dielectric Heater

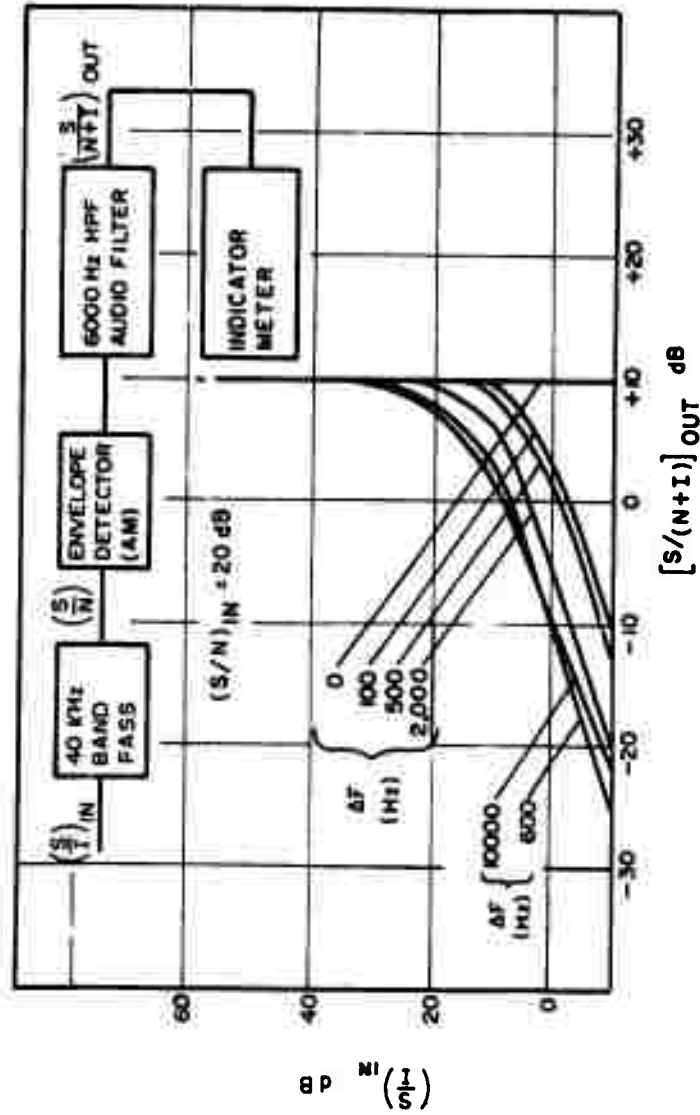

Figure A-20. Analytical Degradation to a VOR Navigation Receiver from a 3-Phase, Full-Wave Dielectric Heater

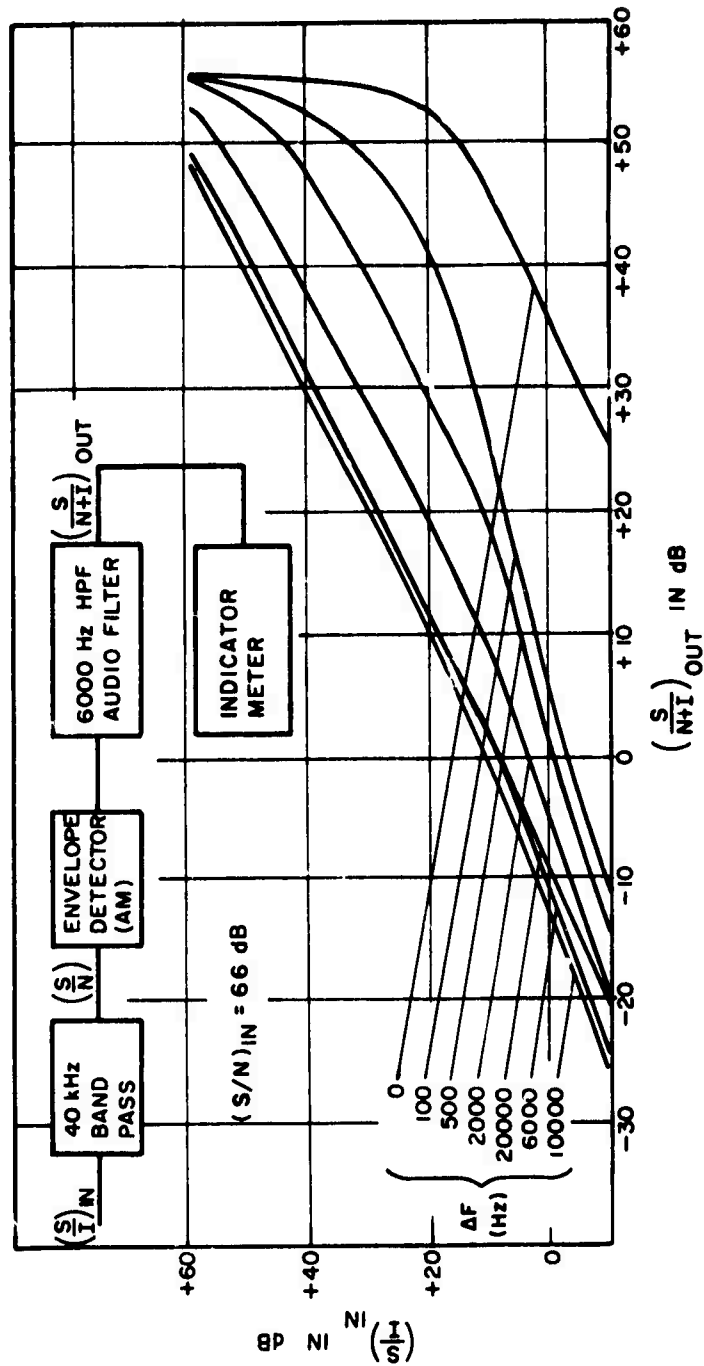

Figure A-21. Analytical Degradation to a VOR Navigation Receiver for a 3-Phase, Full-Wave Dielectric Heater

## APPENDIX B

### MEASUREMENTS

Measurements were performed to determine the degradation in performance of VHF communication and navigation receivers by interference from dielectric heaters and superregenerative receivers. Interfering and desired signals were generated or simulated and then injected into the "victim" receivers; and the performance degradation determined. Measurements were performed on 2 VHF communication receivers, one VOR receiving system and one ILS localizer receiving system.

#### Interfering Signals

*Superregenerative Receiver.* The interference signal characteristic of the radiation from a superregenerative receiver was obtained from a Skywave VHF converter. The converter antenna terminal was connected to a 50 ohm variable attenuator, and the combination was used to simulate a superregenerative waveform of adjustable amplitude.

*Dielectric Heater.* A dielectric heater signal was simulated in the following manner: A three-phase, half-wave, rectified, 60 hertz modulation generator was fabricated and used to amplitude-modulate a radio frequency carrier. The carrier frequency was varied linearly during modulation to simulate the inherent frequency drift characteristics of a dielectric heater. Figure B-1 shows the circuit arrangement of the simulator.

All degradation measurements employed the basic equipment configuration depicted in Figure B-2.

#### Desired Signals

The SG-13 was used to generate three desired signals; 30% AM at 1,000 Hz, ILS localizer and VOR. Figure B-3 shows the emission spectrum of the ILS localizer waveform. Note the 90 Hz and 150 Hz tones equally modulating the carrier at 40%. Figures B-4, B-5, and B-6 show the emission spectrum of the VOR signal. Figure B-4 shows the 9960 Hz subcarrier amplitude modulated at 33%. Figure B-5 shows the 30 Hz tone frequency modulating the 9960 Hz subcarrier at a modulation index of 28.\* Figure B-6 shows the 30 Hz amplitude-modulating the carrier 30%.

---

\* Actual VOR modulation index is on the order of 16.

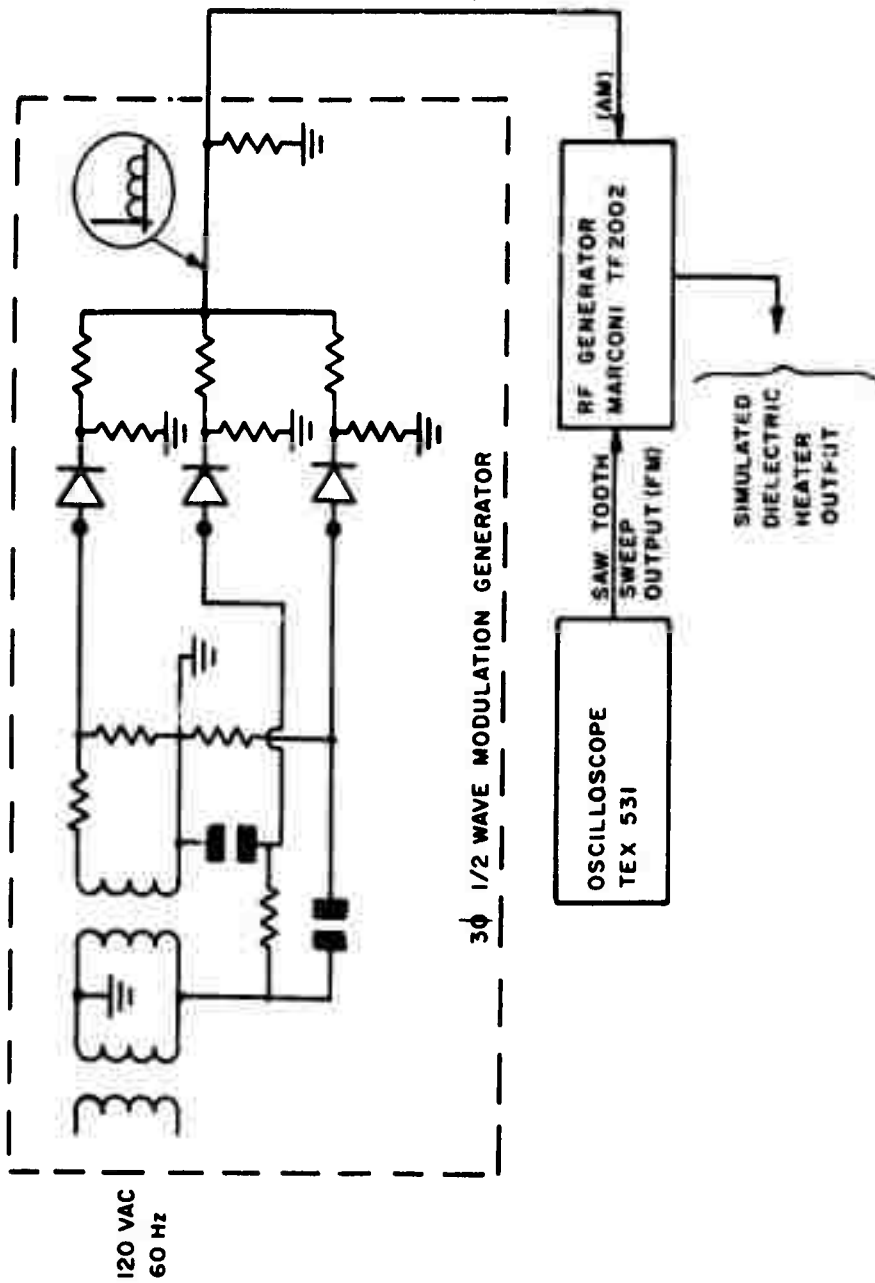

Figure B-1. Simulated Dielectric Heater Circuit

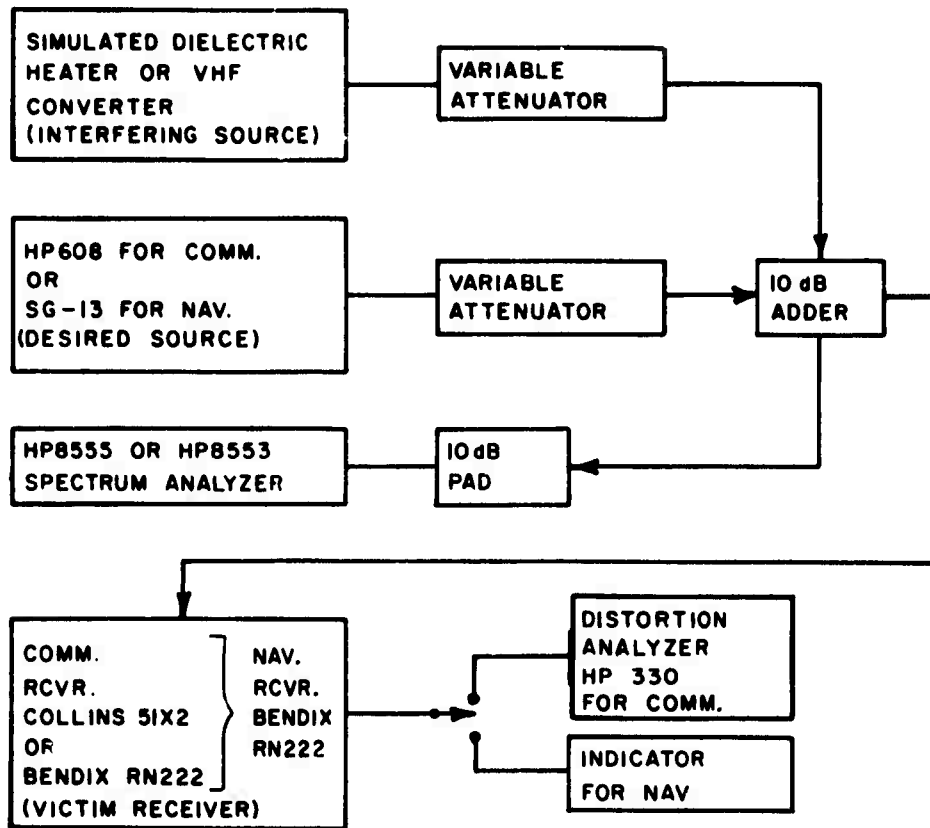
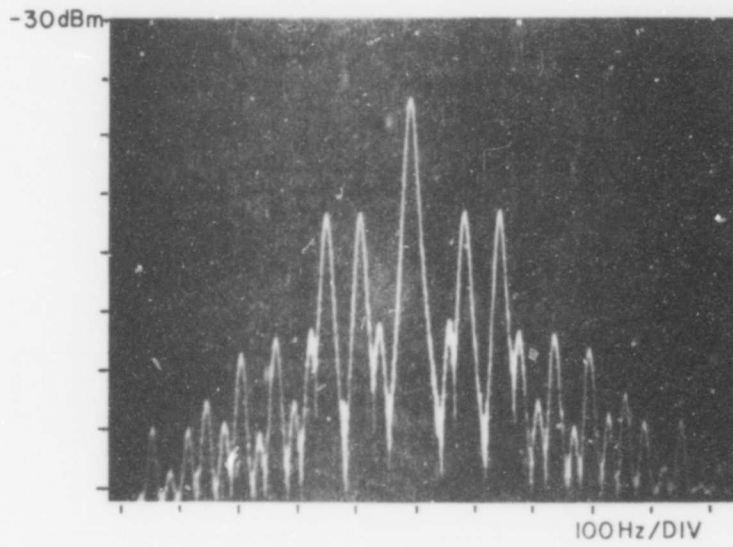

Figure B-2. Basic Equipment Arrangement for Degradation Measurements



Note: Frequencies other than 90 Hz and 150 Hz are distortion products generated within the SG-13 Signal Generator.

Figure B-3. ILS/LOC Spectrum

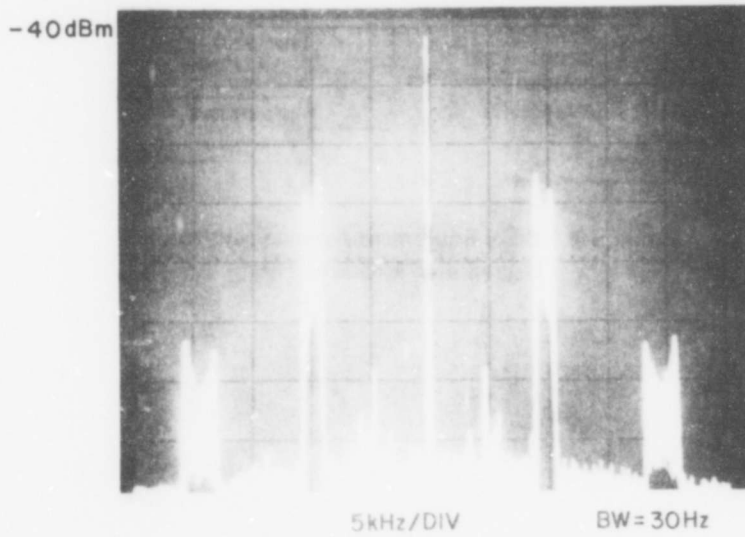

Figure B-4. VOR Spectrum  
(SG-13 Simulator)

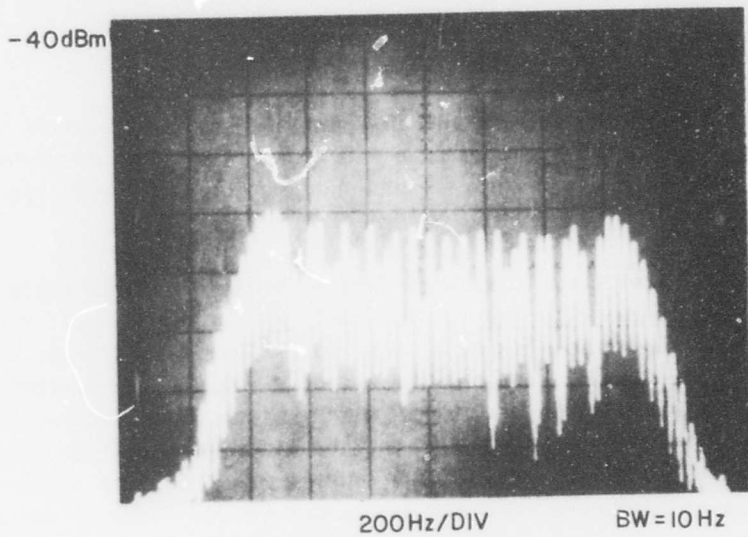

Figure B-5. VOR 9960 Hz Subcarrier  
(SG-13 Simulator)

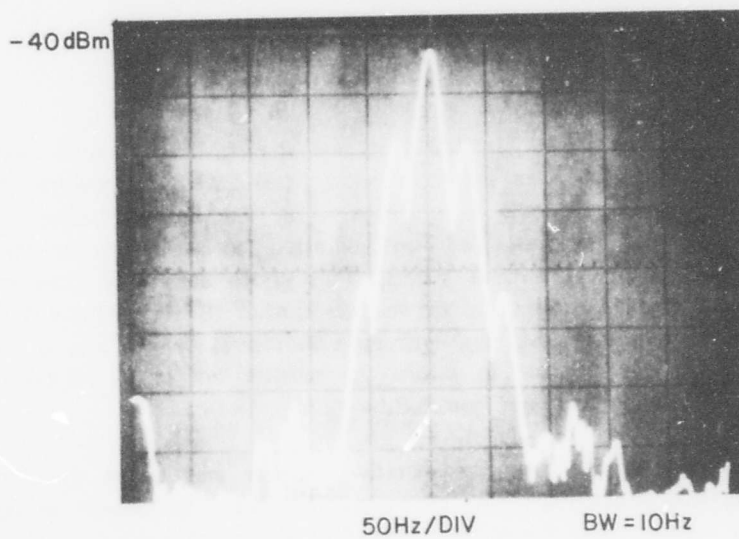

Figure B-6. VOR Carrier  
(SG-13 Simulator)

B-5

### Dielectric Heater Interfering with Communication Receivers

Two tests were performed. In the first test the interfering carrier frequency was swept 100 kHz in five seconds, in the second test the interfering carrier frequency was adjusted to produce a minimum signal-to-interference ratio at the receiver output.

1. A desired signal modulated 30% with 1000 Hz was applied to the Collins 51 X 2 receiver and the input level was adjusted until the output signal-plus-noise-to-noise ratio,  $(S + N)/N$ , was 10 dB. The desired input signal was then increased 3 dB thereby increasing the output  $(S + N)/N$ . The interfering signal, sweeping from 50 kHz below the tuned frequency to 50 kHz above the tuned frequency, was inserted into the receiver and the interfering amplitude was adjusted until the receiver output  $(S + N + I)/(N + I)$  returned to 10 dB. The interfering level was then increased in discrete steps and the output  $(S + N + I)/(N + I)$  was recorded. The procedure was performed for desired input levels of -94 dBm, -84 dBm and -64 dBm. Results are shown in Figure B-7.

2. The second test was similar to the first test with the exception that the interfering frequency was adjusted to produce minimum  $(S + N + I)/(N + I)$  and remained constant throughout the test. The interfering level was varied and the receiver  $(S + N + I)/(N + I)$  was recorded for desired input levels of -95 dBm and -65 dBm. Results are shown in Figure B-7.

### Superregenerative Receiver Interfering with Communication Receiver

Two tests were performed. In the first test the superregenerative receiver was adjusted so that the peak of its spectrum was at 108.2 MHz. Its spectral shape was similar to that shown in Figure B-13, on page B-13. The desired frequency was set to 108.2 MHz and the desired level was adjusted to -99 dBm to produce a  $(S + N)/N$  at the receiver output of 13 dB, 3 dB above sensitivity. The interfering signal was inserted and adjusted until the receiver output  $(S + N + I)/(N + I)$  decreased to 10 dB. The desired level was then increased in discrete steps, and at each step the interfering level was adjusted to return the receiver output  $(S + N + I)/(N + I)$  to 10 dB. The results are plotted in Figure B-8.

For the second test the superregenerative receiver was tuned to a local FM broadcast station resulting in operation in the "quenched mode". The communications receiver was tuned first to 108.1 MHz and second to 109.2 MHz. 109.2 MHz and 108.1 MHz correspond to the maximum and minimum amplitudes of

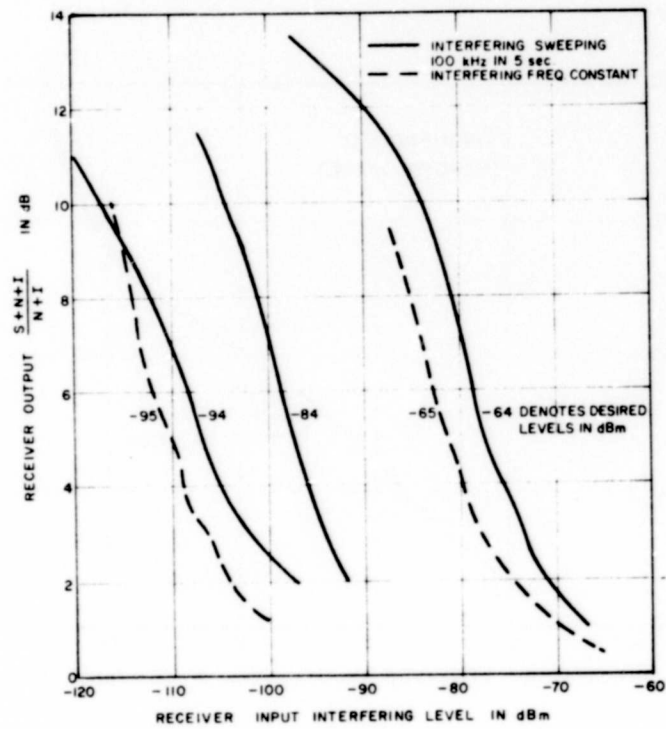

Figure B-7. Communication Receiver Degradation due to Dielectric Heater  $3\phi$  Half Wave

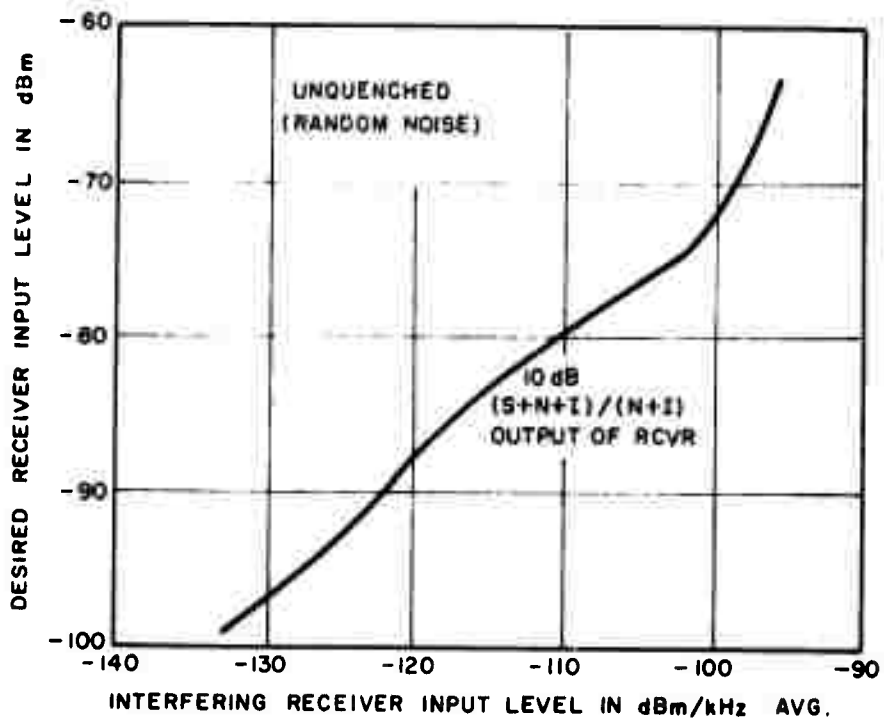

Figure B-8. Communication Receiver Degradation due to Superregenerative Receivers

the interfering spectrum, respectively. At each frequency, measurements similar to those of the first test were performed. The results are shown in Figure B-9. The "quenched" interfering spectrum is shown in Figure B-10.

### **Dielectric Heater Interfering with VOR Navigation Receiving System**

Two output response criteria were employed for the navigation receiving systems measurements.

1. *Flag*—Three flag conditions were used, "full flag" (no receiver input), ½ flag and no flag (operational input signal level).
2. *Bearing*—A one degree change caused by an interfering signal was used as an output criterion.

Two tests were conducted. The first test was performed to determine the interfering level necessary to produce a ½ flag response as the interfering sweep rate was varied. This first test was performed without a desired signal and results are shown on Figure B-11.

For the second test a desired VOR signal,\* Figure B-4, was inserted into the receiver input at 108.2 MHz and the level was increased in 1 dB steps until "no flag" indication appeared. This level occurred at -106 dBm. The desired level was increased by 3 dB and the interference (sweeping 100 kHz in 10 seconds) was inserted into the receiver and its level was increased until a one degree shift in bearing was noted. The interfering level was recorded. The interfering level was further increased until a "full flag" condition appeared. The level was recorded. The desired level was increased in discrete steps and the interfering level was recorded for one degree shift and "full flag" at each desired level. The results are shown in Figure B-12.

### **Superregenerative Receiver Interfering with VOR Navigation Receiving System**

Four tests were conducted. The first test was performed without a desired signal. The receiver was tuned to 108.2 MHz and the maximum of the interfering spectrum was placed at 108.2 MHz, (Figure B-13). This was accomplished by adjusting the tuning knob on the VHF Skywave Converter. The interfering level was increased and the flag response was noted. At an interfering input average power density of -91 dBm/kHz the flag bounced from full flag to ½ flag.

---

\* Simulated by SG-13.

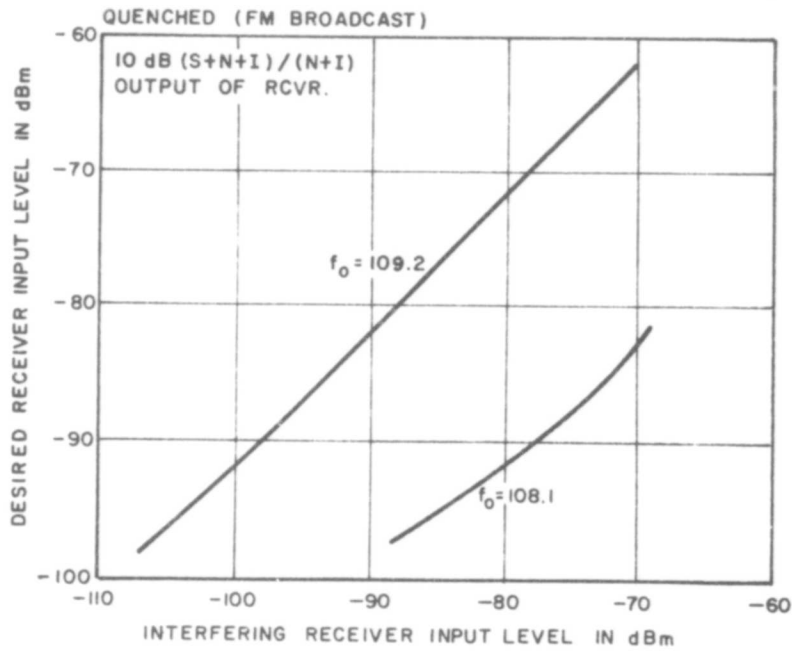

Figure B-9. Communication Receiver Degradation due to Superregenerative Receivers

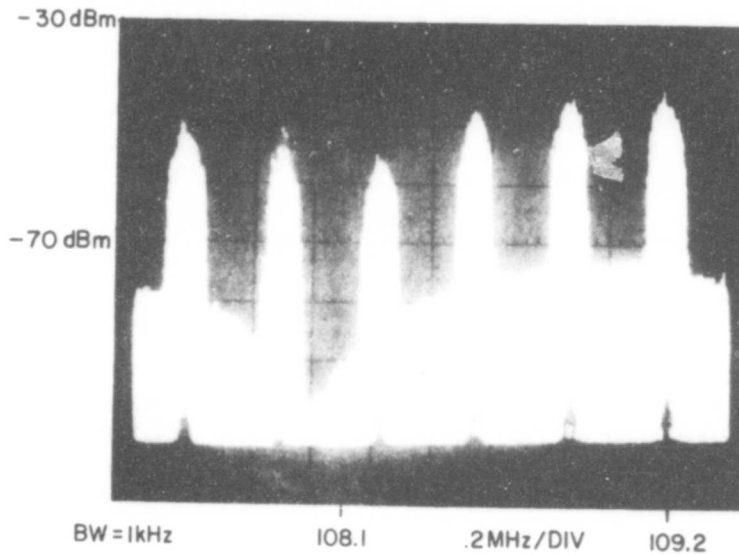

Figure B-10. Quenched Interfering Spectrum

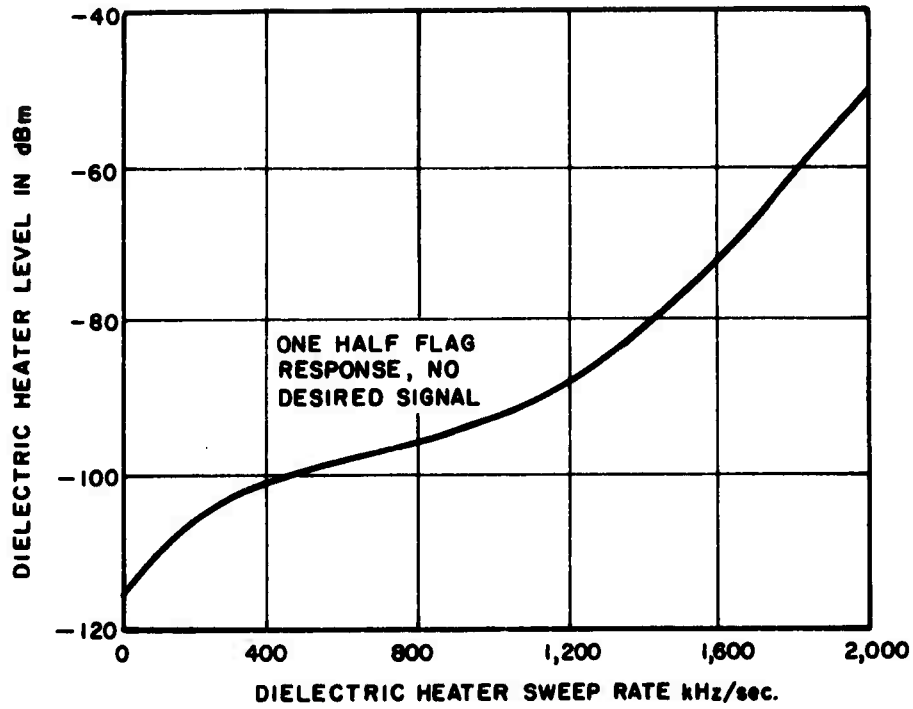

Figure B-11. VOR Navigation Receiving System Degradation due to Dielectric Heater Interference, 3 $\phi$  Half-Wave Modulation

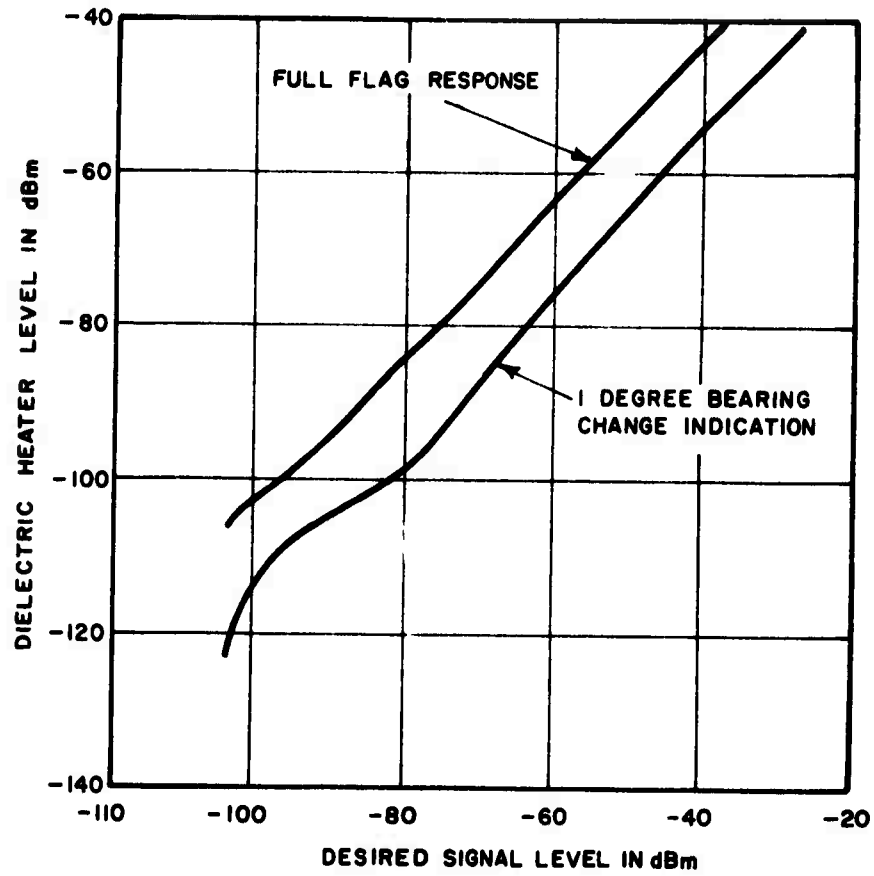

Figure B-12. VOR Navigation Receiving System Degradation due to Dielectric Heater Interference, 3 $\phi$  Half-Wave Modulation

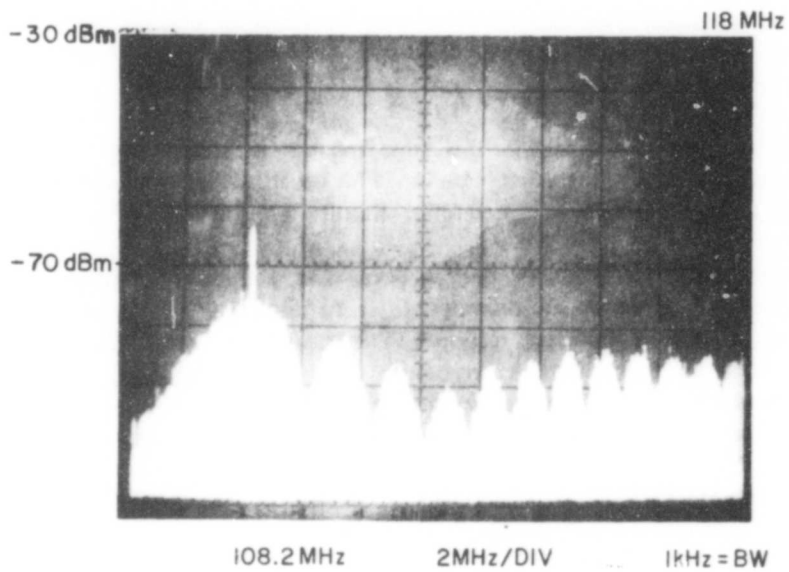

Figure B-13. Superregenerative Converter Spectrum

For the second test the peak of the interfering spectrum was adjusted to 108 MHz. The receiver was tuned to 108.2 MHz and the desired level was set at -103 dBm. The interfering level was adjusted until a one degree shift occurred and until a full flag appeared. The desired level was increased in discrete steps and the interfering level was recorded for full flag and one degree shift responses. The results are shown in Figure B-14.

The third test was performed in the same manner as the second, except that the interfering source was "quenched" by an FM broadcast station signal and the interfering spectrum was peaked at 105.5 MHz. Results are shown on Figure B-15.

In the fourth test the receiver desired level was set to -103 dBm, and the interfering frequency was varied in discrete steps. At each step the interfering level was adjusted to produce a full flag response. The results are shown on Figure B-16. The frequency axis of Figure B-16 corresponds to the dial frequency of the VHF Skywave Converter. The test was performed setting the frequencies on minimums and maximums; the first maximum at 118 MHz (dial) corresponds to 108.2 MHz measured.

#### **Dielectric Heater Interference to Localizer Receiving System**

Three tests were performed. All tests used a "dot" response as an output indication of degradation. Figure B-17 illustrates the navigation indicator. The needle position in Figure B-17 corresponds to the ½ dot position.

For the first test the desired level\* was set 3 dB greater than that level required to cause a no flag response and the desired frequency was set to 109.1 MHz. The interfering level was swept 100 kHz in 10 seconds, centered about 109.1 MHz, and the interfering level was adjusted until ½ dot response occurred. The ½ dot response corresponded to a flag response between no flag and ½ flag. The interfering level was adjusted for dot responses of 1, 2, 3, 4 and 5. The results are shown in Figure B-18.

The second test was performed with the desired frequency at 109.1 MHz and the desired level set at discrete steps. At each step the interfering signal frequency was swept 100 kHz in times ranging from 50 seconds to 0.2 seconds and the interfering level was varied to obtain a ½ dot response. The procedure was repeated for a 3 dot and a 5 dot response. The interfering modulation was three phase half wave with a positive modulation factor of 0.21. Desired input signal-to-interference

---

\* (From SG-13).

ratios were calculated, expressed in decibels and plotted vs. frequency sweep rate in Figure B-19.

The third test was identical to the second test except that the dielectric heater modulation was single phase, full wave with a positive modulation factor of 0.57. The results are plotted in Figure B-20. The 5 dot response was not obtainable.

#### **Superregenerative Receiver Interference to ILS Localizer Receiving System**

The receiver was tuned to 110.1 MHz and the desired signal level was adjusted to  $-102$  dBm. At this level a no flag response was obtained. The unquenched noise interference at 110.1 MHz was inserted into the receiver and its level was adjusted until the no flag condition began to bounce. This condition will be referred to as the "peeping flag". The interference level was further increased until the full flag condition was obtained. The procedure was repeated for discrete desired input levels. The results are plotted on Figure B-21.

The desired signal was removed and the flag changed from "TO" to "OFF", then the interference level was increased to  $-92$  dBm/kHz, average, and no effect was noted at the receiver output flag indication.

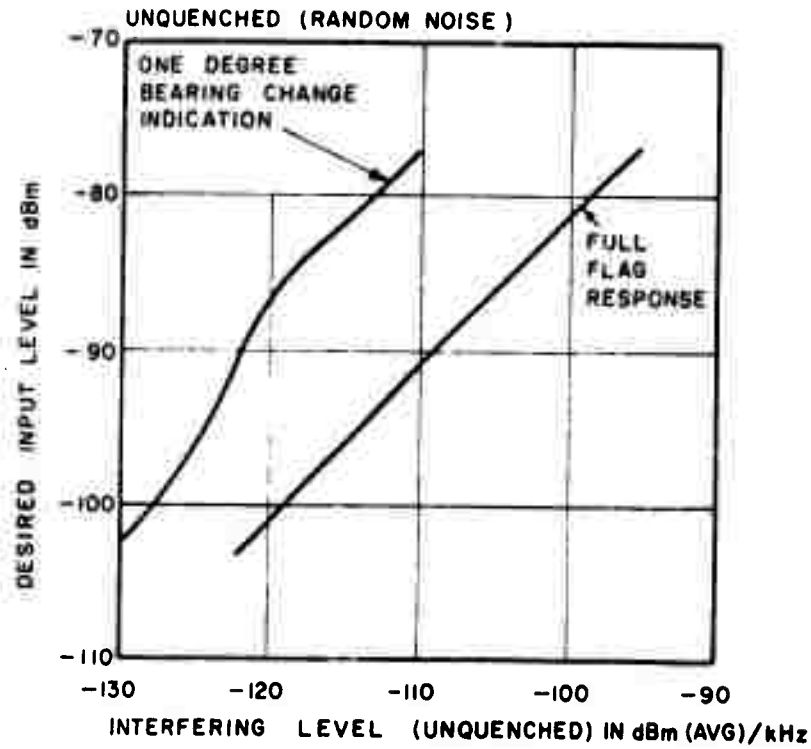

Figure B-14. VOR Navigation Receiving System Degradation due to Superregenerative Receiver Waveforms

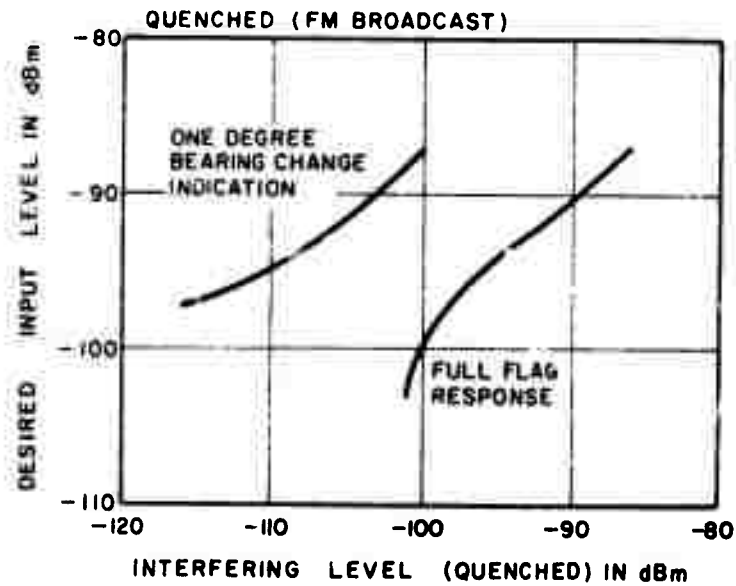

Figure B-15. VOR Navigation Receiving System Degradation due to Superregenerative Receiver Waveforms.

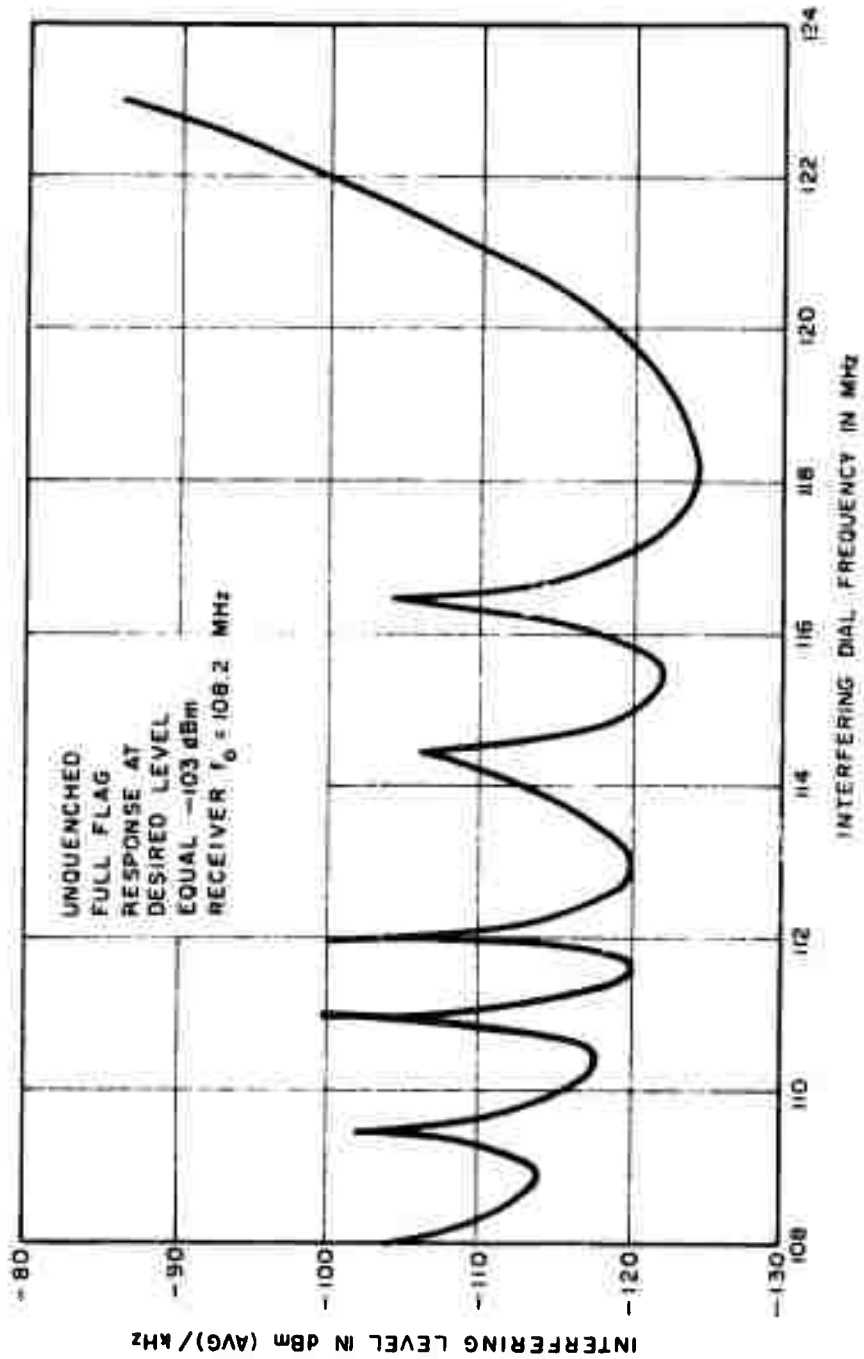

Figure B-16. VOR Navigation Receiving System Degradation due to Superregenerative Receiver Frequency Variation

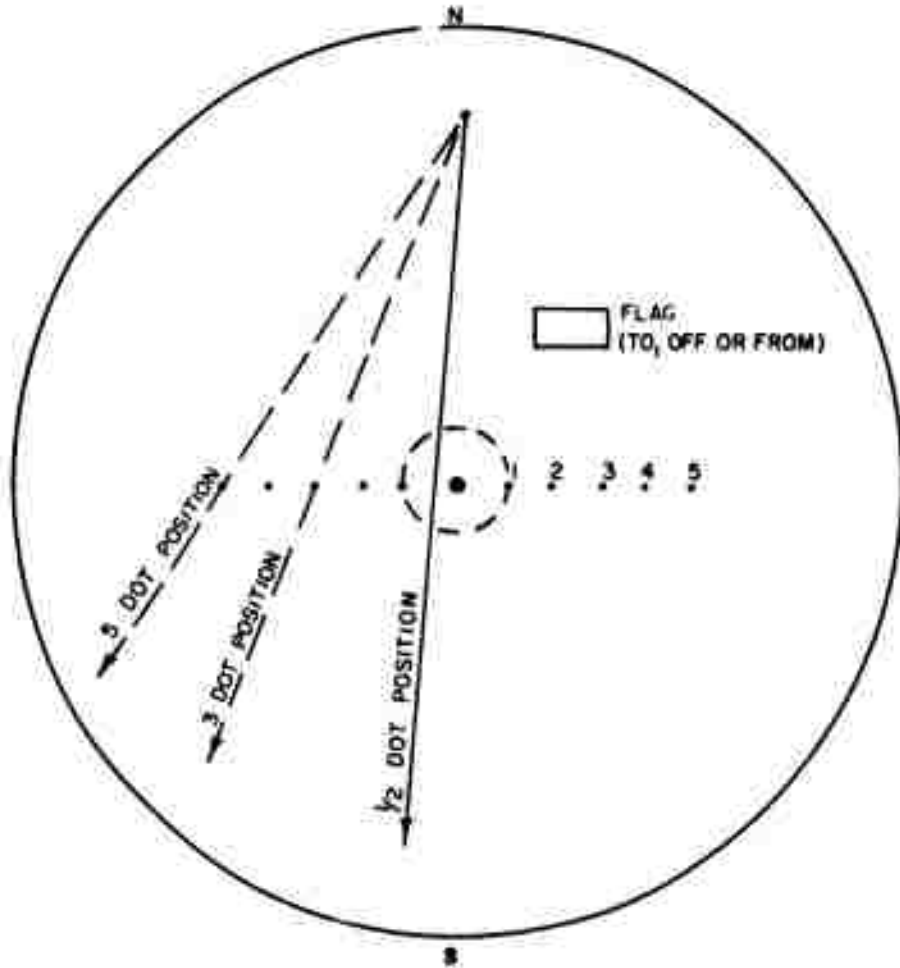

Figure B-17. Navigation Indicator

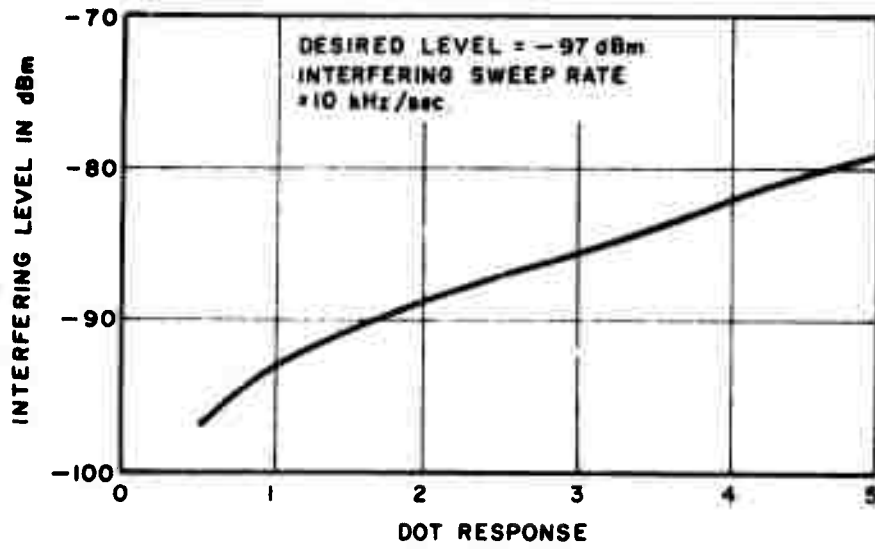

Figure B-18. Localizer Navigation Receiving System Degradation due to Dielectric Heater, 3 Phase Half-Wave,  $m = .21$

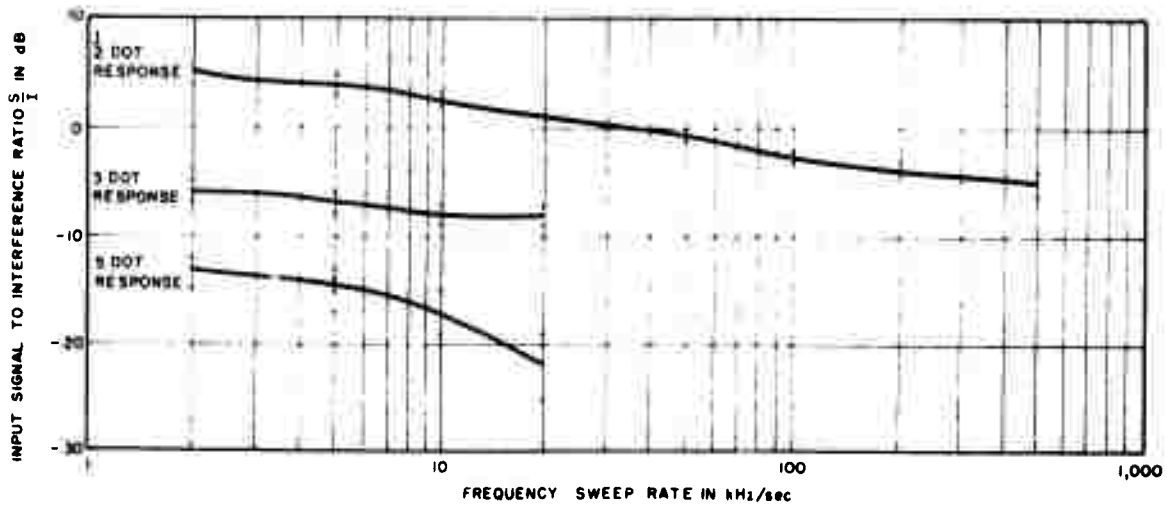

Figure B-19. ILS Localizer Navigation Receiving System Degradation due to Dielectric Heater, 3 Phase, Half Wave,  $m = .21$

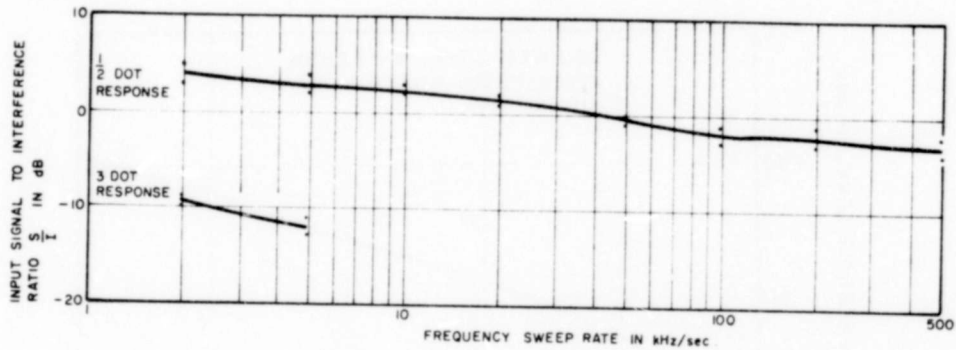

Figure B-20. Localizer Navigation Receiving System Degradation due to Dielectric Heater, Single Phase Full Wave,  $m = .57$

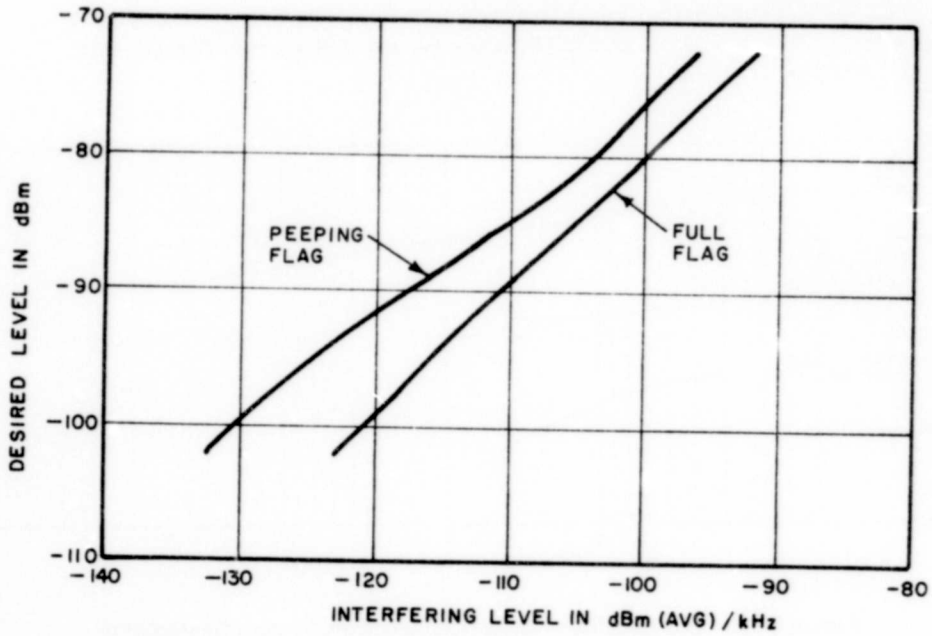

Figure B-21. ILS Localizer Navigation Receiver System Degradation due to Superregenerative Receiver, Unquenched

APPENDIX C

DERIVATION OF EQUATIONS

DEVELOPMENT OF DIELECTRIC HEATER TIME WAVEFORM AND SPECTRUMS SHOWN IN FIGURES 3-1, 3-2 and 3-3

Consider a carrier frequency expression,

$$e = E \cos \omega_o t, \tag{C1-1}$$

where E is the peak amplitude of the radian carrier frequency  $\omega_o$ . If amplitude e is allowed to vary sinusoidally about E for a finite period of time the following equation results,

$$e = Ek \cos \omega_m t \cos \omega_o t, -\frac{T'}{2} \leq t \leq \frac{T'}{2} \tag{C1-2}$$

Figure (C-1) illustrates the basic waveform.

The radian frequency  $\omega_m$  is a slowly varying modulating frequency such that  $\omega_o \gg \omega_m$ . For the 60 Hz dielectric heater power supply  $\omega_m = 2 \pi f = 377$  radians/second and  $T = 1/f = 1/60$  seconds.

Time waveforms and spectrums of three cases of Equation (C1-2) will be determined for,

1. Single phase full wave  $\frac{T'}{2} = T/4$  (C1-3)

2. Three phase half wave  $\frac{T'}{2} = T/6$  (C1-4)

3. Three phase full wave  $\frac{T'}{2} = T/12$  (C1-5)

The average value of the modulating envelope is equal to the peak value of the unmodulated carrier (Reference 8). The constant k in Equation (C1-2) becomes,

$$k = e_{peak} / E \tag{C1-6}$$

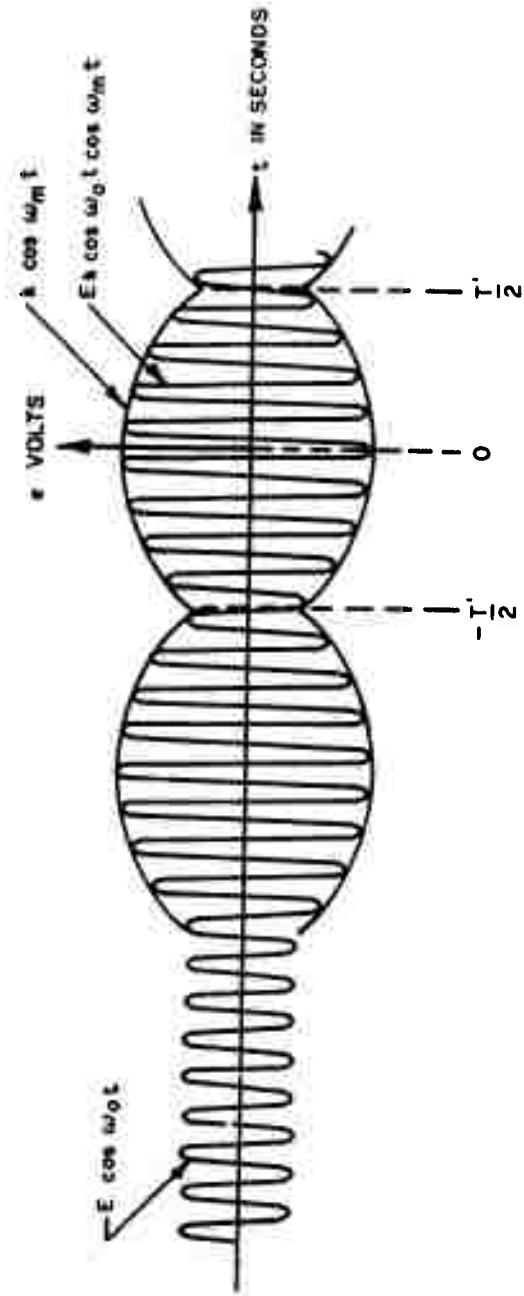

Figure C-1. Dielectric Heater Time Waveform

The average value of the modulating envelope is,

$$E = \frac{1}{T'} \int_{-T'/2}^{T'/2} e_{\text{peak}} \cos \omega_m t dt \quad (C1-7)$$

When Equations (C1-3), (C1-4) and (C1-5) are substituted into Equation (C-17) the ratio of  $e_{\text{peak}} / E$  may be solved for the three cases.

1. Single phase full wave  $k = 1.57$
2. Three phase half wave  $k = 1.21$
3. Three phase full wave  $k = 1.046$

Substituting into equation C1-2,

1. Single phase full wave

$$e_1 = 1.57 E \cos \omega_m t \cos \omega_o t, \quad -\frac{T}{4} \leq t \leq \frac{T}{4} \quad (C1-8)$$

2. Three phase half wave

$$e_2 = 1.21 E \cos \omega_m t \cos \omega_o t, \quad -\frac{T}{6} \leq t \leq \frac{T}{6} \quad (C1-9)$$

3. Three phase full wave

$$e_3 = 1.05 E \cos \omega_m t \cos \omega_o t, \quad -\frac{T}{12} \leq t \leq \frac{T}{12} \quad (C1-10)$$

The Fourier series of equations C1-8, C1-9 and C1-10 (Reference 9) may be found by using;

$$C_n = \int_{-T'/2}^{T'/2} e(t) e^{-j\omega_n t} dt \quad (C1-11)$$

and

$$e(t) = \sum_{-\infty}^{\infty} C_n e^{j\omega_n t} = \frac{2}{T'} \sum_1^{\infty} |C_n| \cos \omega_n t \quad (C1-12)$$

The right hand side of Equation (C1-12) is valid when the function  $e(t)$  has zero average value.

When Equation (C1-2) is substituted into Equation (C1-11) and the assumption is made that  $\omega_o \gg \omega_m$ ,

$$C_n = \frac{Ek}{2} \left[ \frac{\sin(\omega_o + \omega_m - \omega_n) \frac{T'}{2}}{\omega_o + \omega_m - \omega_n} + \frac{\sin(\omega_o - \omega_m - \omega_n) \frac{T'}{2}}{\omega_o - \omega_m - \omega_n} \right] \tag{C1-13}$$

Inserting the solutions for three cases of  $C_n$  into Equation (C1-12) results in,

1. Single phase full wave

$$e_1 = E \cos \omega_o t + \frac{E}{3} \cos(\omega_o \pm 2\omega_m) t - \frac{E}{15} \cos(\omega_o \pm 4\omega_m) t + \frac{E}{36} \cos(\omega_o \pm 6\omega_m) t - \dots \tag{C1-14}$$

2. Three phase half wave

$$e_2 = E \cos \omega_o t + \frac{E}{8} \cos(\omega_o \pm 3\omega_m) t - \frac{E}{35} \cos(\omega_o \pm 6\omega_m) t + \frac{E}{80} \cos(\omega_o \pm 9\omega_m) t - \dots \tag{C1-15}$$

3. Three phase full wave

$$e_3 = E \cos \omega_o t + \frac{E}{35} \cos(\omega_o \pm 6\omega_m) t - \frac{E}{143} \cos(\omega_o \pm 12\omega_m) t + \frac{E}{323} \cos(\omega_o \pm 18\omega_m) t - \dots \tag{C1-16}$$

Equations (C1-14), (C1-15) and (C1-16) are plotted in Figures 3-1, 3-2, and 3-3.

**DEVELOPMENT OF VOR DESIRED SIGNAL, EQUATION (3-1)**

A carrier frequency of 9960 Hz frequency-modulated with a 30 Hz modulating tone is expressed as (Reference 9):

$$e_1 = \cos (2 \pi 9960t + \beta \sin 2 \pi 30t) \tag{C2-1}$$

where

$$\beta = \frac{\Delta f}{f_m} = \frac{\Delta f}{30} = \text{modulation index}$$

When  $e_1$  amplitude modulates the carrier frequency,  $f_o$  30%

$$e_2 = \left\{ 1 + .3 \cos (2 \pi 9960t + \beta \sin 2 \pi 30 t) \right\} \cos 2 \pi f_o t \tag{C2-2}$$

If another 30 Hz tone is used to amplitude modulate the same carrier frequency 30%

$$e = \left\{ \begin{aligned} &1 + .3 \cos (2 \pi 9960t + \beta \sin 2 \pi 30t) \\ &+ .3 \cos (2\pi 30t + \phi) \end{aligned} \right\} \cos 2\pi f_o t \tag{C2-3}$$

where  $\phi$  is the phase difference between the two 30 Hz tones.

**DEVELOPMENT OF SIGNAL- TO-INTERFERENCE RATIO, EQUATION (3-5)**

Assuming free space transmission loss, the desired power density is;

$$P_D = \frac{ERP_s}{4\pi d_s^2} \tag{C3-1}$$

where

$ERP_s$  = desired effective radiated power

$d_s$  = distance between desired transmitter and receiver

The received desired signal power is (see Reference 8)

$$s = P_R = \frac{G \lambda^2 E^2}{480 \pi^2 MM} = \frac{G \lambda^2 P_D}{4 \pi MM} \tag{C3-2}$$

where  $P_D = \frac{E^2}{120\pi}$ , and MM = Mismatch Factor

Combining Equation (C3-1) and (C3-2)

$$s = \frac{ERP_s G \lambda^2}{16 \pi^2 MM d_s^2} \tag{C3-3}$$

Similarly the received interfering power is

$$i = \frac{ERP_i G \lambda^2}{16 \pi^2 MM d_i^2} \tag{C3-4}$$

where

$ERP_i$  = interfering effective radiated power

$d_i$  = distance between interferer and receiver

Dividing Equation (C3-3) by (C3-4)

$$\frac{s}{i} = \frac{ERP_s d_i^2}{ERP_i d_s^2} \tag{C3-5}$$

For the NAV transmitter and dielectric heater the ERP used was + 50 dBm and + 15 dBm respectively.

Taking  $10 \log_{10}$  of both sides of Equation (C3-5) results in

$$\frac{S}{I} = 35 + 20 \log (d_i/d_s) \tag{C3-6}$$

and

$$(4-5)$$

For the COMM transmitter and dielectric heater the ERP used was + 44 dBm and + 15 dBm respectively.

Taking  $10 \log_{10}$  of both sides of Equation (C3-5) results in,

$$\frac{S}{I} = 29 + 20 \log (d_1/d_0) \quad \text{(C3-7)}$$

and  
(4-2)

## APPENDIX D

### RECEIVER SELECTIVITIES

Before performing the degradation tests, selectivity measurements were performed on the navigation and communication receivers.

Receiver IF amplifier selectivities were measured by inserting a modulated signal (30% at 1000 Hz) into the receiver and adjusting the input amplitude and frequency until a 10 dB  $(S+N)/N$  ratio was obtained at the output for a minimum input level. The input level was then increased by 3 dB and the frequency was varied until the output response returned to 10 dB  $(S+N)/N$ . The process was repeated for the 6, 10, 20, 30, 40, 50 and 60 dB points. Figure D-1 shows the selectivity curve of the Collins 51 x 2 receiver. In addition to the unusual asymmetry of the curve, a beat note was discovered at approximately 50 kHz below the center frequency. Figure D-2 shows the selectivity curve of the Bendix RN22 receiver.

Audio selectivities were measured by inserting a 30% modulated signal into the receiver and adjusting the amplitude until maximum  $(S+N)/N$  was obtained at the audio output. Then the input signal level, frequency and modulation factor were held constant, the audio modulating frequency was varied, and the receiver audio output voltage and  $(S+N)/N$  were recorded.

Figures D-3 and D-4 are the audio selectivities for the Collins and Bendix receivers respectively. The Bendix receiver has a 1000 Hz notch filter that may be switched in the audio circuits. The selectivity effect of this filter on the audio selectivity is shown in Figure D-5. Figure D-6 is the audio selectivity of the 90 Hz and 150 Hz tone localizer portion of the navigation section of the Bendix receiver.

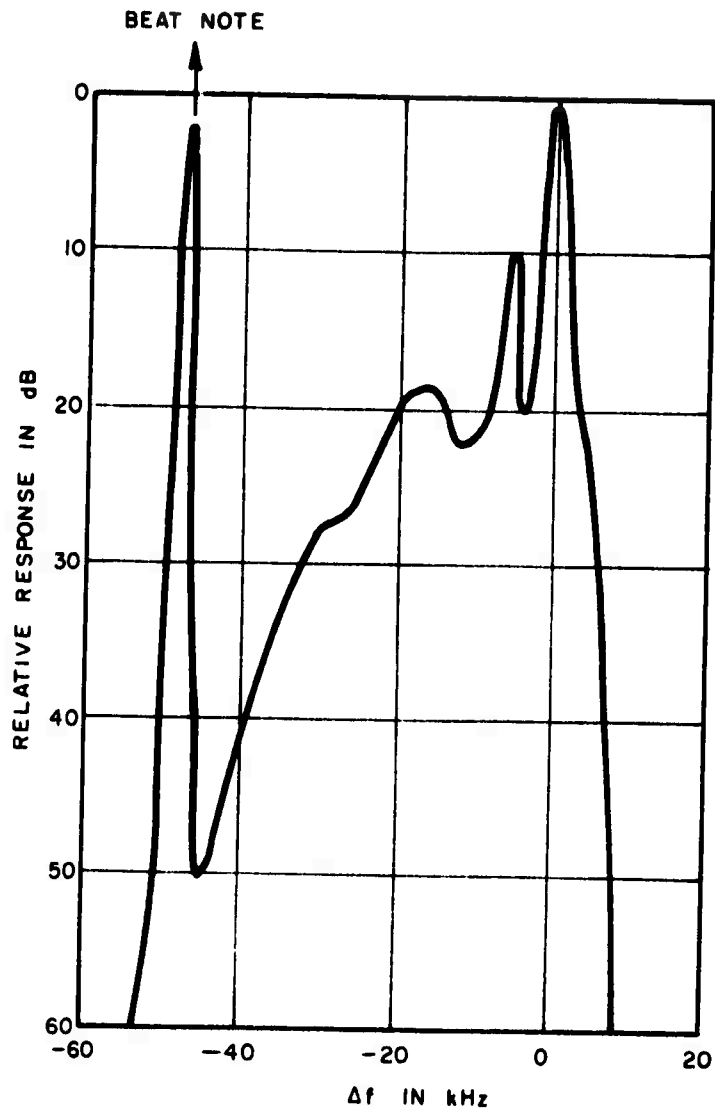

Figure D-1. IF Selectivity of Collins 51 x 2 Receiver, Tuned to 118.0 MHz

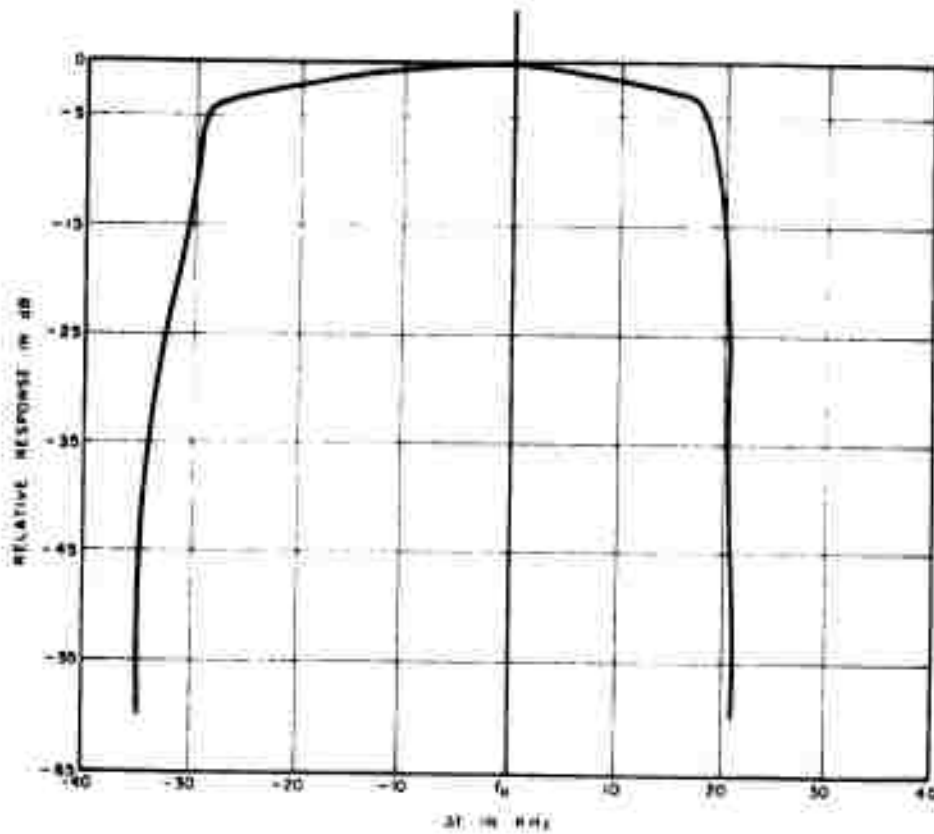

Figure D-2. IF Selectivity of Bendix RN22 Receiver, Tuned to 109.2 MHz

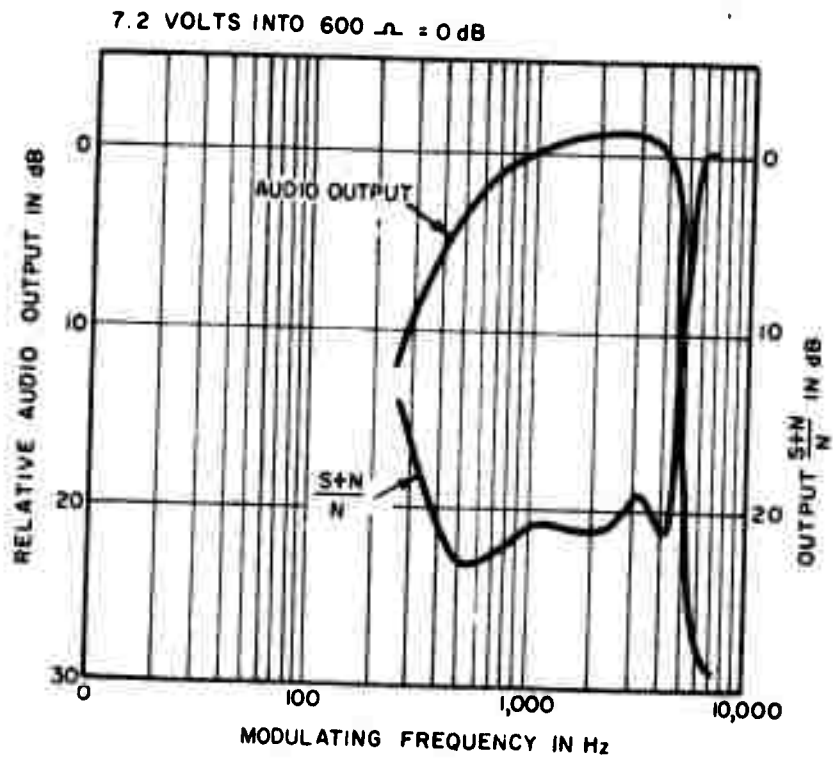

Figure D-3. Audio Selectivity of Collins 51 x 2 Receiver, Tuned to 118.0 MHz

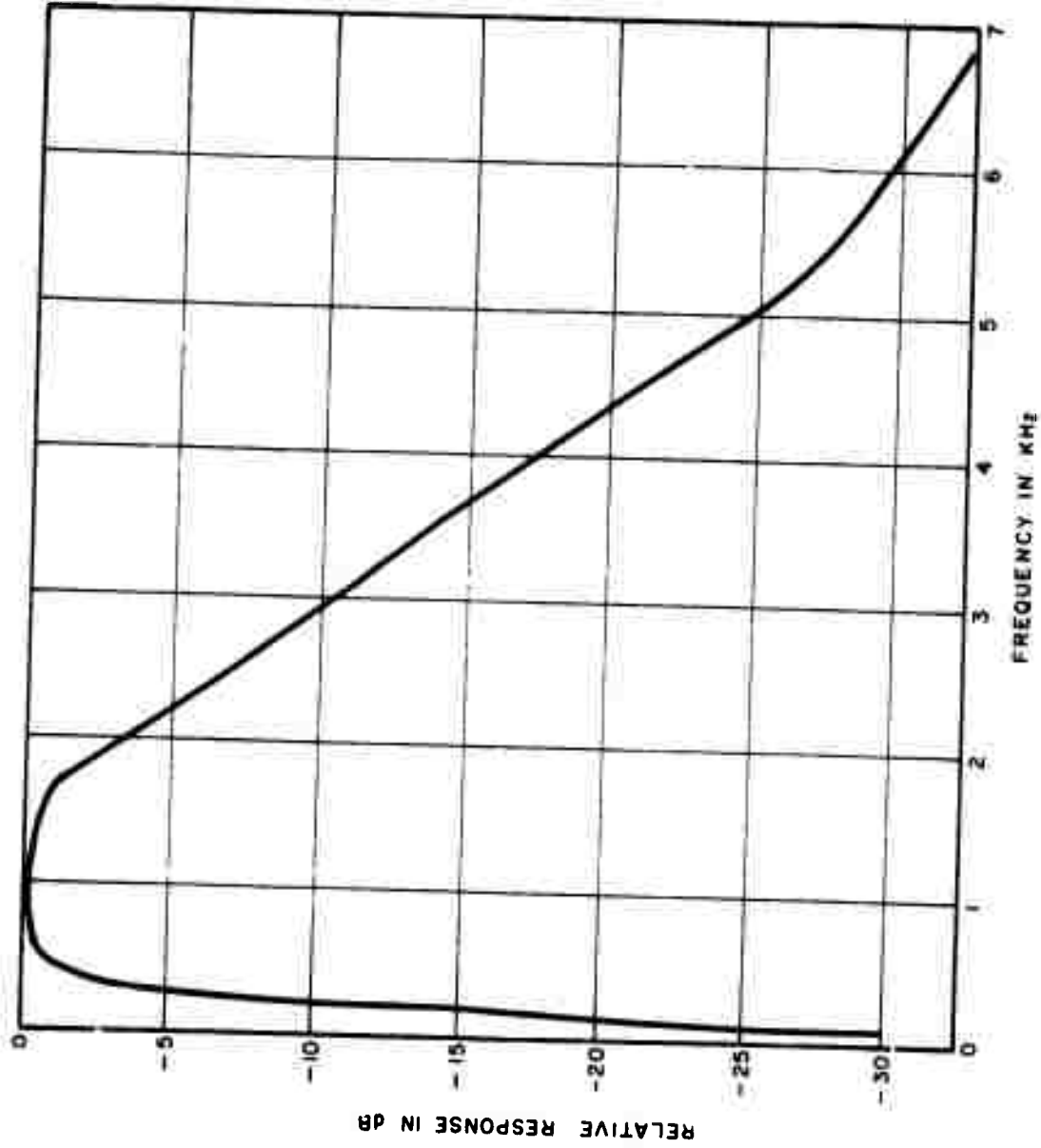

Figure D-4. Audio Selectivity of Bendix RN22 Receiver, Tuned to 109.2 MHz

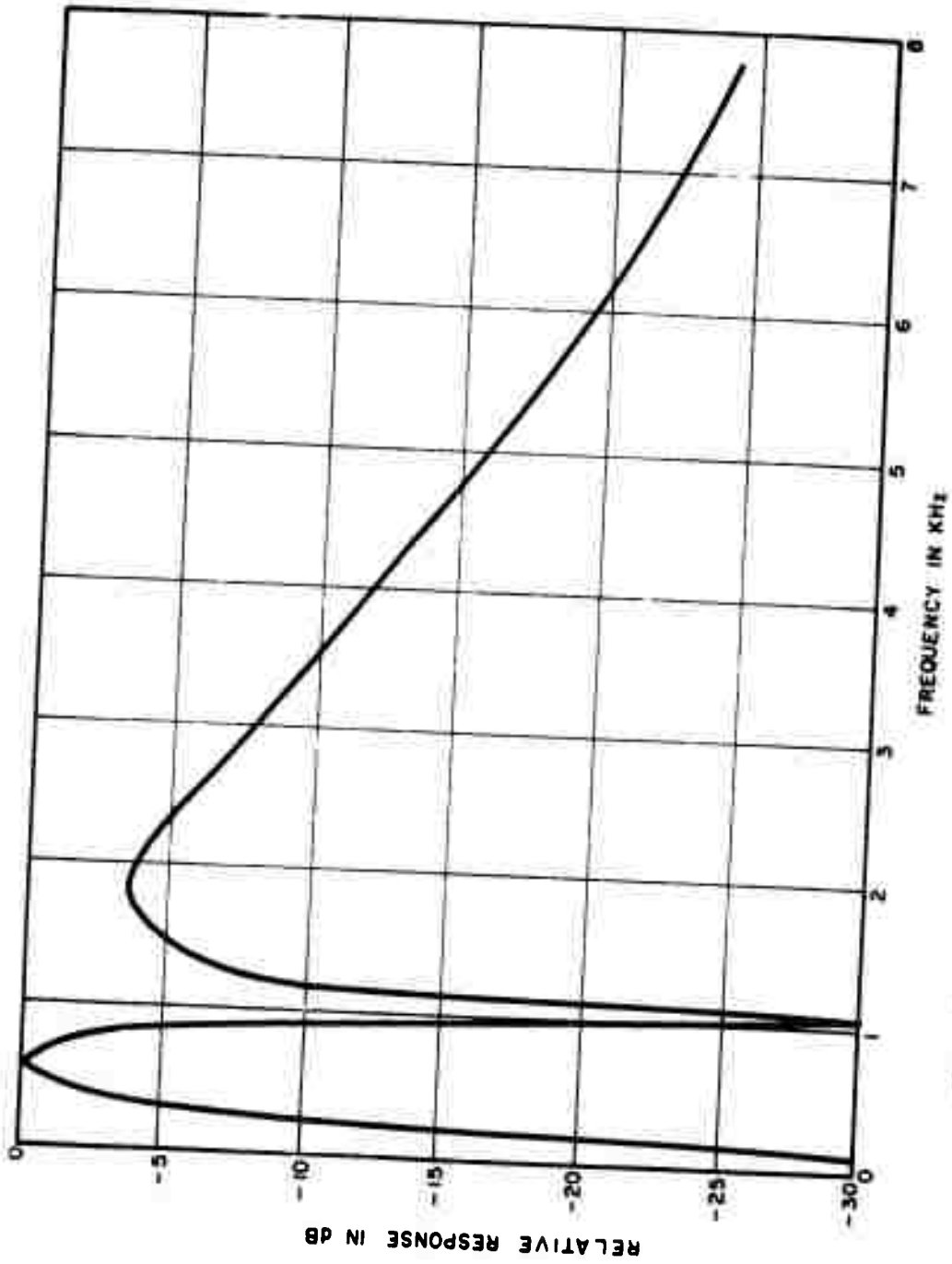

Figure D-5. Audio Selectivity of Bendix Receiver with Notch Filter

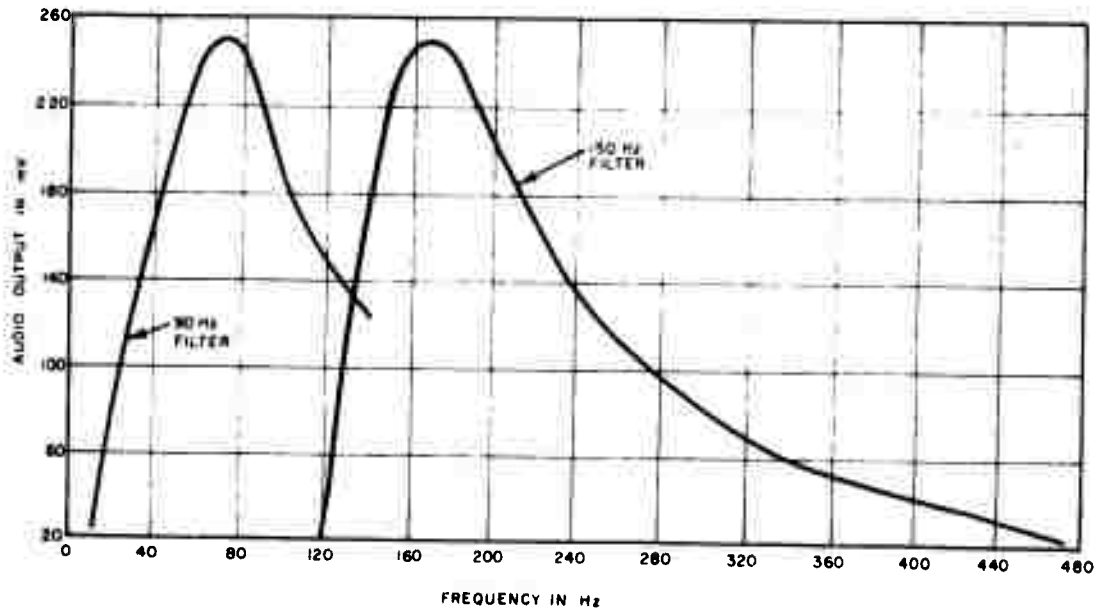

Figure D-6. Measured Audio Selectivity of Localizer Receiver

REFERENCES

1. FAA Handbook 6050.23, *Frequency Management Principles Spectrum Engineering Measurements*, 29 May 1969.
2. Inter-Agency Agreement DOT-FA70WA1-175, Task Assignment No. 10, subitem b.
3. Martin, H., Tabor, F., *Radio Frequency Emission Characteristics and Measurement Procedures of Incidental Radiation Devices and Industrial Scientific and Medical Equipment*, FAA Report FAA-RD-72-80, I, September 1972
4. Meyers, R., *A Receiver Waveform Simulation (RWS) Model*, ESD-TR-71-099, Electromagnetic Compatibility Analysis Center (ECAC), August 1971.
5. Chandler, D. S., Chambers, R. W., *The Probability Scoring Model for Scoring Voice Communications Reception*, USAEPG-IR-268, U. S. Army Electronics Proving Ground, August 1966.
6. Maiuzzo, M., Frazier, W., *A Theoretical Ground Wave Prediction Model, Nλ Model*, ESD-TR-68-315, December 1968.
7. FAA Handbook 6050.4A *VHF/UHF Air/Ground Communications Frequency Engineering Handbook*, 3 June 1965.
8. Terman, F., *Electronic and Radio Engineering*, Fourth Edition, 1955.
9. Schwartz, M., *Information Transmission, Modulation, and Noise*, 1959.