

AD-771 192

AGARD FLIGHT TEST INSTRUMENTATION SERIES.
VOLUME 4. THE MEASUREMENT OF ENGINE
ROTATION SPEED

M. Vedrunes

Advisory Group for Aerospace Research and
Development
Paris, France

October 1973

DISTRIBUTED BY:

NTIS

National Technical Information Service
U. S. DEPARTMENT OF COMMERCE
5285 Port Royal Road, Springfield Va. 22151

AD-771 192

NORTH ATLANTIC TREATY ORGANIZATION
ADVISORY GROUP FOR AEROSPACE RESEARCH AND DEVELOPMENT
(ORGANISATION DU TRAITE DE L'ATLANTIQUE NORD)

AGARDograph No.160 Vol.4
THE MEASUREMENT OF ENGINE ROTATION SPEED

by

M.Vedrunes

Volume 4

of the

AGARD FLIGHT TEST INSTRUMENTATION SERIES

Edited by

W.D.Mace and A.Pool

Reproduced by
NATIONAL TECHNICAL
INFORMATION SERVICE
US Department of Commerce
Springfield, VA. 22151

DDIC
RECEIVED
DEC 26 1973
E

DISTRIBUTION STATEMENT A
Approved for public release;
Distribution Unlimited

This AGARDograph has been sponsored by the Flight Mechanics Panel of AGARD.

THE MISSION OF AGARD

The mission of AGARD is to bring together the leading personalities of the NATO nations in the fields of science and technology relating to aerospace for the following purposes:

- Exchanging of scientific and technical information;
- Continuously stimulating advances in the aerospace sciences relevant to strengthening the common defence posture;
- Improving the co-operation among member nations in aerospace research and development;
- Providing scientific and technical advice and assistance to the North Atlantic Military Committee in the field of aerospace research and development;
- Rendering scientific and technical assistance, as requested, to other NATO bodies and to member nations in connection with research and development problems in the aerospace field;
- Providing assistance to member nations for the purpose of increasing their scientific and technical potential;
- Recommending effective ways for the member nations to use their research and development capabilities for the common benefit of the NATO community.

The highest authority within AGARD is the National Delegates Board consisting of officially appointed senior representatives from each member nation. The mission of AGARD is carried out through the Panels which are composed of experts appointed by the National Delegates, the Consultant and Exchange Program and the Aerospace Applications Studies Program. The results of AGARD work are reported to the member nations and the NATO Authorities through the AGARD series of publications of which this is one.

Participation in AGARD activities is by invitation only and is normally limited to citizens of the NATO nations.

The material in this publication has been reproduced directly from copy supplied by AGARD or the author.

Published October 1973

621.438:621-25:681.124



Printed by Technical Editing and Reproduction Ltd
Harford House, 7-9 Charlotte St, London. W1P 1HD

PREFACE

Soon after its foundation in 1952, the Advisory Group for Aeronautical Research and Development recognized the need for a comprehensive publication on flight test techniques and the associated instrumentation. Under the direction of the AGARD Flight Test Panel (now the Flight Mechanics Panel), a Flight Test Manual was published in the years 1954 to 1956. The Manual was divided into four volumes: I. Performance, II. Stability and Control, III. Instrumentation Catalog, and IV. Instrumentation Systems.

Since then flight test instrumentation has developed rapidly in a broad field of sophisticated techniques. In view of this development the Flight Test Instrumentation Committee of the Flight Mechanics Panel was asked in 1968 to update Volumes III and IV of the Flight Test Manual. Upon the advice of the Committee, the Panel decided that Volume III would not be continued and that Volume IV would be replaced by a series of separately published monographs on selected subjects of flight test instrumentation: the AGARD Flight Test Instrumentation Series. The first volume of this Series gives a general introduction to the basic principles of flight test instrumentation engineering and is composed from contributions by several specialized authors. Each of the other volumes provides a more detailed treatise by a specialist on a selected instrumentation subject. Mr W.D.Mace and Mr A.Pool were willing to accept the responsibility of editing the Series, and Prof. D.Bosman assisted them in editing the introductory volume. AGARD was fortunate in finding competent editors and authors willing to contribute their knowledge and to spend considerable time in the preparation of this Series.

It is hoped that this Series will satisfy the existing need for specialized documentation in the field of flight test instrumentation and as such may promote a better understanding between the flight test engineer and the instrumentation and data processing specialists. Such understanding is essential for the efficient design and execution of flight test programs.

The efforts of the Flight Test Instrumentation Committee members and the assistance of the Flight Mechanics Panel in the preparation of the Series are greatly appreciated.

T.VAN OOSTEROM
Member of the Flight Mechanics Panel
Chairman of the Flight Test
Instrumentation Committee

CONTENTS

	Page
PREFACE	iii
LIST OF SYMBOLS	vi
1.0 INTRODUCTION	1
2.0 CHRONOTACHOMETERS	1
2.1 Principle of Operation	1
2.2 Design of Airborne Measuring Systems	2
3.0 TACHOGENERATORS	2
3.1 Principle of Operation	3
3.2 Design of an Airborne Measuring System	3
3.3 Advantages and Disadvantages of Tachogenerators and Eddy-Current Synchronous Indicators Used for Engine rpm Measurements	4
3.4 Various Types of Existing Equipment	4
3.5 Power Supply	5
3.6 Measurement Recording	5
3.6.1 <i>Photographic Recording</i>	5
3.6.2 <i>Telemetry Transmission</i>	5
3.6.3 <i>Analog Magnetic Recording</i>	6
3.6.4 <i>Digital Magnetic Recording</i>	7
3.6.4.1 <i>Frequencymeter</i>	7
3.6.4.2 <i>Periodmeter</i>	7
3.7 Transducers Compatible with Various Recording Techniques	8
3.8 Scale Expander	9
4.0 MAGNETIC SENSORS	9
4.1 General	9
4.1.1 <i>Proximity Detectors</i>	9
4.1.2 <i>Magnetic Sensors Referred to as "Phonic Wheel"</i>	9
4.1.3 <i>Mobile Permanent Magnet Associated with a Fixed Coil</i>	9
4.2 Design of an Airborne Measuring System	10
4.2.1 <i>Direct Installation of the System on the Engine Without Drive</i>	10
4.2.2 <i>Installation Using a Shaft Drive</i>	10
4.2.3 <i>Measurement Recording</i>	10
4.3 Advantages and Disadvantages	10
4.4 Existing Equipment	11
4.5 Power Supply	11
5.0 COMPARISON OF THE THREE PREVIOUSLY DESCRIBED SPEED MEASUREMENT TECHNIQUES	11
6.0 CALIBRATION OF ROTATION SPEED MEASUREMENT SYSTEMS	12
APPENDIX	
1.0 ROTATION SPEED MEASURING DEVICES FORMERLY USED ON AIRCRAFT	13
1.1 Centrifugal Tachometer	13
1.2 DC Generators	13
2.0 OTHER ROTATION SPEED MEASURING TECHNIQUES NOT YET USED FOR AIRBORNE APPLICATIONS	13
REFERENCES	14
FIGURES	15

LIST OF SYMBOLS

<u>Symbol</u>	<u>Meaning</u>
B	magnetic induction
C	capacitance
C	torque
E	electrical voltage
f	pulse rate
F	frequency
f'	centrifugal force
g	grams
H	magnetic field
I	current
k	constant
M	weight
n	number of revolutions, pulses, etc.
N	speed of rotation
Q	charge
r	radius
rpm	revolutions per minute
R	resistance
T	t.m.s
t	time constant
U	supply voltage
V	voltage
ω	angular velocity
σ	conductivity
Subscript	
\bar{x}	mean value
o	output
Abbreviation	
MIL	U.S. Military Standards
BNAc	Bureau de Normalisation Aéronautique

THE MEASUREMENT OF ENGINE ROTATION SPEED

by

M. Vedrunes
Centre d'Essais en Vol
Bretigny sur Orge
France

1.0 INTRODUCTION

Measurements of rotation speed are common in flight test programs, and are particularly important in engine tests. In some instances, these measurements appear as an intermediate variable in the measurement of a parameter of primary interest, such as, fuel flow or torque. In the measurement of fuel flow, e.g., one commonly used sensor utilizes a spinner which is immersed in and is driven by the flowing fuel so that the rotation speed of the spinner is proportional to flow rate. In certain torque measurements, two rotation speed measurements are made in such a way that the phase shift between them is proportional to torque.

There are other instances, of course, in which the speed of rotation is, itself, the precise variable of interest, as is generally the case in engine measurements.

Thus in flight test programs, it can be seen that measurements of rotation speeds provide:

- (1) an intermediate step in obtaining measurements of some parameters of primary interest,
- (2) functional checks of engine performance in such events as flame out, relight, instability, and stabilized descent,
- (3) the determination of engine performance characteristics.

The discussion presented in this AGARDograph is primarily concerned with the analysis of the techniques and systems used to measure rotation speeds. The application of these data in research and/or evaluation programs is a subject that will be left to other authors. Generally, engine functional checks involve engine speed (rpm) measurements under transient conditions to examine power variations for changes in engine speed of up to 15-20 percent of the maximum, and to detect and analyze possible periodic low frequency (< 5 Hz) and low amplitude (up to a few percent) phenomena. Conversely, engine performance calculations require measurements made at several stabilized power settings which are slowly varied. Measurements accurate to about ± 0.15 percent are required in this application.

The following discussion will first deal with chronotachometers, which are used principally on light aircraft, then with the two types of sensors widely used on aircraft for measuring engine rpm; i.e.:

- the four-pole and two-pole, three-phase, tachogenerators
- the magnetic sensors (phonic wheel and proximity detector).

Finally, a comparison between these three systems together with a review of the calibration techniques used with rotation speed measurement systems will complete this document. Various measurement processes, not often used in flight tests, are briefly described in the appendix which may prove useful in solving some specific problems.

2.0 CHRONOTACHOMETERS

2.1 Principle of Operation

Chronotachometers are designed for measuring the mean rotation speed of a moving shaft during the portion of a second that precedes the measurement. The principle of operation is as follows (Figure 1):

A clockwork, wound by friction through the rotational motion whose speed is to be measured, distributes the time into equal periods during which it successively engages and disengages a primary wheel linked to the shaft rotation. The primary wheel (a) is first, driven via the moving shaft by an angle proportional to the measurand (wheel engaged), then, returned to its initial position (wheel disengaged) through a return spring. When the spring reaches its maximum elongation, it drives an auxiliary wheel (b) integral with a pointer. As the primary wheel begins to return to its initial position, the auxiliary wheel/pointer assembly is uncoupled and fixed in position. If the speed increases, while the primary wheel is engaged, both the auxiliary wheel and the pointer will be driven by the primary wheel; conversely, if the speed decreases, they will be returned to zero through the action of the return spring until the primary wheel drives them again. The pointer is moved by small increments, almost unperceptible to the eye, and continuously indicates the rotation speed.

If $t_2 - t_1$ is the time interval during which the primary wheel is engaged and n is the number of shaft revolutions during the corresponding time, then the shaft rotation speed N_m will be obtained by the following formula:

$$N_m = \frac{n}{t_2 - t_1}$$

2.2 Design of Airborne Measuring Systems

The airborne measuring system includes a means for transmitting the shaft rotational motion to the tachometer, the tachometer itself, and the measurement recording equipment, if available. The transmission of the shaft rotational motion to the chronotachometer is usually through a flexible drive shaft. The maximum permissible speed for this kind of installation depends upon the length and the bends in the flexible shaft and ranges from 2,000 rpm to 4,000 rpm. According to BNAe' PRL 34-420 Standard (Ref 1), the maximum speed is 3,000 rpm. This Standard also specifies as a bending limit, the minimum distance between the shaft drive and bend start to be 50 mm and the bending radius for a 90 degree angle to be at least 150 mm.

The recording of the rotation speed measurement as directly supplied from a chronotachometer is not feasible. When the aircraft tachometer system includes such a unit, the measurement of the rotation speed together with the recording on a photographic recorder is generally performed either by means of a device called a time pulser, or by measuring at constant time intervals the angular position of a shaft whose rotation speed is a portion of that to be measured.

In the time pulser (Figure 2), the position of the rotating wheel is detected by a mechanical link which activates an electrical contact (time signal), the rotation speed measurement being derived from the measurement of the time interval between two contacts. The time pulser consists of a light alloy body, a single-thread worm screw, and a 100-tooth ring gear. The latter features a boss which actuates a pawl at each revolution of the ring gear, thus producing a time signal every hundred revolutions of the engine shaft. These time signals are recorded on a photographic recorder whose time base makes it possible to measure the time interval between two electrical contacts provided the contact indications can be easily identified (to this end the paper speed must be high enough to obtain at least 0.2 mm between indications). The time pulser is usually connected directly to the engine drive (Figure 3 and Figure 4).

For measurement of the shaft angular position at constant time intervals, a potentiometer is coupled to the shaft through a mechanism which permits it to be immobilized every second at the position reached by the shaft. Figure 5 illustrates an instrument configuration which permits the mean rotation speed of jet engine to be recorded at one-second intervals. It operates as follows: the shaft, integral with the rotational motion whose speed is to be measured, can drive a soft iron disk carrying two springs and a lug. An electro-magnet, controlled by the recorder timer, attracts, when energized, the disk which comes to rest and disengages the driving stops. The lug then comes into contact with the potentiometer. As soon as the disk is released, it is pushed back by the springs thus enabling the driving stops (pin and cam follower) to come into contact. During the time the disk is driven by the shaft, the lug is clear of the potentiometer.

The accuracy of the rotation speed measurement depends solely on the measurement accuracy of time interval $t_2 - t_1$. Therefore, it corresponds to that of the clockwork; i.e.:

$$\frac{\Delta N_m}{N_m} = - \frac{\Delta t}{t}$$

The calculation of accuracy may be illustrated by the following example: assuming that the reading accuracy of the recorded time base is 0.4 mm, then to obtain a one percent accuracy of the speed measurement, it will be necessary to measure the time interval corresponding to a paper displacement of 40 mm.

The operation of a chronotachometer does not require a power supply. The clockwork is friction rewound from the rotational motion whose speed is to be measured.

3.0 TACHOGENERATORS

Most of the aircraft presently in service are fitted with tachometer systems which include a tachogenerator as the sensor. The generator is used in conjunction with an eddy-current type indicator. The general layout in Figure 28 shows the various configurations for recording engine rotation speed measurements using tachogenerators.

3.1 Principle of Operation (Figure 6)

A tachogenerator is a small alternator including one or two sets of pole pieces which supplies a three-phase current whose frequency is proportional to the rotation speed to be measured. It consists of a permanent magnet rotor rotating within a wound stator. The stator has three windings whose axes are geometrically displaced from one another by 120° so as to generate a three-phase signal. The generator may feature four poles but two-pole generators can accommodate magnets having a higher BH specific energy and, therefore, are preferred.

The three-phase voltage supplied from the generator drives a synchronous motor at a speed equivalent to that of the generator rotor. The synchronous motor utilizes a stator that is similar to that in the generator, although smaller in size. Its permanent magnet rotor includes the same number of pole pieces as that of the generator. The three-phase alternating current induces a rotating magnetic field in the synchronous motor and subjects the rotor to a torque causing it to rotate at the same speed as the generator. The rotating rotor is used to drive an eddy-current tachometer. This type of tachometer consists of a permanent magnet system rotated by the shaft whose speed is to be measured. Thus the field produced by these magnets is a rotating one which generates eddy-currents within a drag cup which itself will be driven in rotation through the action of the field upon these currents.

The torque driving the cup in rotation is proportional to the rotation speed N, the electrical conductivity, and the square of induction B (this term is squared because the forces acting on the cup are proportional to the induction and to the field acting upon these currents), hence:

$$C = K N B^2$$

Under the action of the return spring, the cup comes to a balance position depending on value N of the rotation speed, thus:

$$\theta = K N B^2$$

(in this formula, θ corresponds to the angle by which the cup has been rotated with respect to the position selected as a reference).

Note: Some manufacturers install a disk or a metal drum instead of the above mentioned cup.

3.2 Design of an Airborne Measuring System

A rotation speed measuring system fitted with a tachogenerator includes the coupling of the shaft to the generator, the tachogenerator itself, the transmission of the generator motion to an indicator, the indicator and a recorder.

Coupling of the shaft rotational motion to the generator can be performed using a flexible shaft where the limitations are similar to those stated in paragraph 2.2 for the chronotachometers. Usually, however, the generator is attached to a gear box which, in turn, is mechanically coupled to the shaft whose rotation speed is to be measured. The gear ratio used, is a function of the maximum rpm to be measured as specified in MIL-I-7069, dated 29.12.1950 and BNAe' PRL-72-120 Standards, i.e.: the step-down ratio is 1/2 for a maximum rpm less than 10,000 rpm, 1/4 for a maximum rpm from 8,000 to 20,000 rpm, 1/10 for a maximum rpm from 16,000 to 50,000 rpm.

Various configurations are available for transmission of the generator output to the indicator depending on whether the generator is installed solely for the tests or serves both the aircraft operational system and the tests. In some cases, a single indicator can serve the needs of both the aircraft system and the tests while in others separate systems are required. Some of the configurations that may be encountered with a tachogenerator are:

- one aircraft indicator without recording means
- two aircraft indicators without recording means
- one aircraft indicator with recording means
- two aircraft indicators, one with and one without recording means.

If several drives are available, one tachogenerator may be installed for measuring purposes only (Figure 9). Sometimes, an additional drive can be provided, as illustrated in Figure 3, or several generators may be stacked on a single drive (Figure 10).

In transmitting the generator output to the indicator(s), the line length and resistance affect only the driving torque of the indicator's synchronous motor, which, in turn, affects the lowest speed at which the indicator will stay in sync with the generator. This speed is closely dependant upon the motor temperature. For two-pole miniature

generators, this speed is higher than with four-pole generators and its value is doubled when two motors are connected in parallel to the same generator (the engagement speed of a synchronous motor connected with a two-pole generator is approximately 250 rpm whereas its disengagement speed is about 100 rpm. If the indicator is subjected to temperatures as high as 60°C, the engagement speed may reach 1,500 rpm with two indicators connected in parallel). The electrical wiring must be shielded and incorporate three wires each having a minimum cross-section of 0.4 mm (Specification PRL 72-126).

The measurement recording can be performed either from a tachogenerator installed for the tests, from an indicator provided with a recording output, or from an instrument similar to the indicator but suited for recording. It is also possible to record one phase of the three-phase signal developed by the aircraft generator. This process is not recommended because of safety considerations; i.e., a measurement circuit failure could affect the information displayed to the pilot and the introduction of a phase unbalance in the signal from the generator.

Techniques for recording the output of tachogenerators will be discussed in paragraph 3.6; this subject being of sufficient importance to be dealt with separately.

3.3 Advantages and Disadvantages of Tachogenerators and Eddy-Current Synchronous Indicators Used For Engine rpm Measurements

The engine rpm measurements performed with such devices involve the transmission of an electrical voltage where the information is contained in the signal frequency. The measurement is not feasible at low rotation speeds but, as soon as the synchronous indicator engages, the rotation speed to be measured by the eddy-current tachometer exactly corresponds to that of the tachogenerator. Thus, the measurement accuracy is determined by the eddy-current tachometer.

The construction of the latter is simple, light and their measurement range, 200 rpm to 5,000 rpm, is well suited for flight tests. The time constant involved is acceptable for most of the applications and the accuracy obtained is ± 0.5 percent. Such devices, however, require a prestabilization treatment of the magnets in order to produce a constant magnetic field. Long term stability of the magnetic field, and hence, system geometry, continues to be a problem. Furthermore, as they are particularly affected by temperature variations, it is necessary to provide them with a compensating device. It has been demonstrated that a temperature variation causes the following:

(a) A change in conductivity, σ , of the eddy-current disk. The alloy generally used for the drag cup is selected according to its high conductivity (12 times that of copper) and low density (1/3 that of copper). Its conductivity variation is similar to that of copper; i.e., 0.4 percent per degree centigrade. This value corresponds to an average rotation speed error of -6 percent for a temperature variation of +100°C. (The purpose of the above mentioned selection criteria is to obtain a maximum drive torque of the rotating disk, this torque being proportional to conductivity, σ , and to minimize the errors due to friction.)

(b) A change in the magnetic field generated by the permanent magnets. This field decreases as the temperature increases. As a result, the torque acting upon the drag cup, due to the presence of eddy-currents, is proportional to the square of induction B; i.e., the square of the magnetic field generated by the magnets, induction B being equal to the product of magnetic field H times the permeability. The error in rotation speed due to temperature changes is -0.05 percent per degree centigrade; i.e., a temperature variation of 100°C corresponds to a rotation speed error of -5 percent.

(c) A change in width of the gap, since the expansion of the permanent magnet supports is greater than that of the magnets. This gap variation may be reduced through the use of INVAR magnet supports. In that case, a temperature variation of +100°C corresponds to a rotation speed error of -1 percent. Therefore, when the temperature decreases, the driving system (magnets and drag cup) tends to indicate an excessive rotation speed value whereas the torque on the return spring increases. An appropriate heat treatment of the metal disk alloy allows the temperature coefficient to be correctly matched with that of the return spring. If the temperature of the spring and the disk are nearly identical, which usually happens, the tachometer being housed in a closed box, the errors resulting from temperature variations will cancel each other. The magnets must be compensated by magnet keepers which also serve to regulate the flux across the gap containing the drag cup.

It is to be noted that the tachogenerator temperature range is limited to +150°C.

3.4 Various Types of Existing Equipment

Until 1967, airborne generators were heavy (from 750 to 1,250 g.) and bulky; they included two pairs of pole pieces and a rotation speed limit of 5,000 rpm. According to BNA: PRL 75-122 Standard, the maximum module of the indicators associated with these generators is limited to 57 and they are calibrated in percent: 100 percent = 4,200 rpm.

All of these generators have approximately the same characteristics; i.e.,

no-load voltage at 1,500 rpm: 36 V rms,

operating voltage into a non-inductive circuit of 200: 3 V rms at 300 rpm.

Voltage variation versus speed is linear as follows:

20 mV/rpm with a conventional four-pole indicator, 16 mV/rpm with two conventional four-pole indicators.

Since 1967, miniature generators weighing approximately 320 g. (Figure 12) have been available, which are about one-half the size of the previously mentioned generators (see Figure 9). The two-pole generators are normally intended for driving one or two indicators, although with two indicators the engagement speed is higher than that obtained with the older tachogenerators. The rotation speed of the newer generators is limited to 10,000 rpm. The module of the synchronous indicators normally associated with these generators is as follows:

BNAe 50 for a single indicator (2 in. diameter case)

BNAe 57 for a dual indicator and

BNAe 60 for a triple indicator (see Figure 13)

3.5 Power Supply

This type of engine rpm measurement system does not require a power supply.

3.6 Measurement Recording

The engine speed measurements are usually recorded in flight on a photographic or magnetic recorder and/or telemetered to the ground. Various signal conditioners have been developed to accommodate these different applications. Some of these are specific to a given type of recording device, while the more recently produced units are general purpose.

1. Photographic Recording

The three phase signals delivered by the tachogenerator may be recorded using a tachometer which can be used for both a photographic recorder and an indicator. This device is referred to as a P51 tachometer. This is an eddy-current tachometer derived from the aircraft tachometers and adapted for use with the A13 photographic recorders. It is widely used in France for flight tests. This tachometer (see Figures 14a and 14b) consists of a drag cup (3), subjected to eddy-currents, which drives a mirror wheel (5) whose position therefore depends upon the rotation speed to be measured. The mirror wheel (5) located in front of lens (6) reflects via mirror (7) the light ray emitted by the recorder lamp towards the recording slot.

For each of the mirrors in the P51 tachometer, a full sweep of the slot corresponds to a 500 rpm rotation speed of the generator and the mirror distribution avoids any gaps in the measurement range. The measurement range of the P51 tachometer is from 150 to 5,000 rpm. The instrument features 24 mirrors and affords an accuracy of about ± 5 rpm for constant engine speed. Although this was almost the only type of tachometer used in France from 1957 to 1967, it was not entirely satisfactory for the two following reasons:

(1) There is no "coarse scanning" allowing several mirrors to be sensed. Various techniques have been used to alleviate this deficiency, all of which are based on the rectification of the voltage from the generator.

(2) For some tests, the response of the P51 tachometer is too slow. Comparisons of the responses of the generator output which has been rectified (constant delay equal to 0.14 sec) and recorded on photographic paper using a P51 tachometer, with fast rotation speed variations of the generator, indicate that the P51 tachometer introduces a significant time delay (see Figures 15 and 16).

Currently, the most frequently used P51 tachometers are of the four-pole type although, a two-pole version has been developed which is compatible with the new two-pole generators. P51 tachometers are directly mounted into the A-13 photographic recorders (see Figure 17). However, a number of precautions must be observed in installing certain types of galvanometers in a recorder fitted with a P51 tachometer. Depending on the aircraft indicator used, it is also necessary to check whether the parallel-connection of a P51 tachometer is feasible. Whereas the P51 tachometer does not require a power supply, provision does have to be made to power the lamp in the photographic recorder.

3.6.2. Telemetering Transmission

If the aircraft incorporates telemetry then the capability for real-time monitoring of rotation speed variations may be provided on the ground. Similar design problems are encountered whether the signals are to be telemetered, or recorded. In order to limit the number of telemetry channels required for engine rpm measurement, it is necessary to convert the three-phase signal from the generator into single-phase signal. The latter can then be read on the ground using a frequency meter.

The three-phase to single-phase conversion of the signal generally implies a frequency multiplication of the signal since the signal frequency from the tachogenerator is generally too low to obtain the accuracy desired in the engine tests. This frequency multiplication of the signal is an advantage since it frequently avoids the need to install an additional generator having a greater number of poles.

This conversion has been successively accomplished using the following techniques:

(1) A 10-ohm resistor is connected in series with one phase of the P51 tachogenerator-indicator system. The stability of the voltage across the resistor terminals is better than that of the interphase voltage supplying the aircraft indicator. The lock-on thresholds, however, of the P51 tachometer-indicator assembly are higher. This practice is not recommended because the impedances of the tachogenerators and indicators are adjusted to provide the correct matching of the units which could be impaired by the insertion of an additional resistor.

(2) Frequency tripler. The three-phases of the current supplied from the generators are star-connected (commonly referred to as Y-connected in the US). The phases are connected through diodes, to a junction point where the voltage is continuously equal to that of the phase having the highest algebraic value (Figures 18-19). Such a device does not require power supply.

(3) Frequency multiplier x12 (four-pole generator signal) and x 13 (two-pole generator signal) (Figure 20). The system includes two secondary windings, one being star-connected and the other delta-connected. The voltages across each terminal of the star-connected secondary winding and the junction point are phase-shifted by $2\pi/3$. The voltages across the terminals of the delta-connected secondary winding are phase-shifted by $\pi/6$ with respect to the previous ones. These six voltages are rectified by means of mid-point transformers and 12 diodes. The latter connect the transformer outputs with a junction point where the voltage is continuously equal to that of the phase having the highest algebraic value. The signal frequency multiplication by ratios of 6:1 or 12:1 simplifies the measurement functions but the design of a double-hexaphase system is complicated and requires a number of precautions. Such a device is supplied with 28V DC and requires less than 50 mA.

(4) Generation of square-wave signals using an optical device integral with the airborne indicators: P55 tachometer (Figure 21). A circular element incorporating 120 white and black strips is made integral with the synchronous motor of the rpm indicator. This element is illuminated by a lamp and as it rotates the lighting variations are viewed by a photodiode. After shaping the photodiode output, the resultant signal is a square wave with a frequency 60 times higher than the rotation speed of the element. The advantages of such a device are:

(a) A failure in the recording system has no effect on the aircraft indicator, and,

(b) The higher signal frequency permits good accuracy through pulse counting. On the other hand, the measurement can only take place after the airborne indicator has locked on. This arrangement is better than the P51 tachometer system because there is one less indicator (a P51 tachometer is generally connected in parallel with the aircraft indicator). This device requires a 28V DC supply and requires less than 50 mA.

(5) Recovery of a three-phase signal from a telemetered single phase signal. In order that the measurement may be displayed and recorded on the ground using an indicator similar to the airborne indicator, and a photographic recorder, equipments have been developed which can simultaneously drive telemetry discriminators and two parallel-connected indicators (an aircraft indicator and a P51 tachometer). The principle of operation is as follows: a supply voltage U is successively applied through three switches to the three terminals of an indicator coil (see Figure 22). The switching rate of the switches depends upon the frequency of the signal from the telemetering discriminator. The various currents flowing through the three indicator coils are shown in Figure 22. These three currents are equally phase shifted by $1/3$ of a period with relation to each other.

The power supply of such a device is either 127-220V, 50 Hz, single-phase; 115-208V, 400 Hz, three-phase; or 28V DC.

With a load of two indicators, 0.5A is required at 220V.

3.6.3 Analog Magnetic Recording

As a result of the standardization of the input specifications, the problems encountered in telemetering and recording the rotation speed of a three-phase tachogenerator are similar. Two differences, however, are to be noted:

(1) For analog magnetic recording, there is no point in recovering a three-phase signal.

(2) The single-phase signal can be directly processed on a computer. This operation, however, is practical only if the computer is already dedicated to the tests which require the measurement of the rotation speed.

3.6.4 Digital Magnetic Recording

Digital acquisition systems permit pulse counting. Thus, to adapt the signal from the tachogenerator to a digital recording system, it is necessary, as in the case of the French AJAX telemetering transmission and analog magnetic recording, to perform three-phase-to-single-phase signal conversion where the frequency is some multiple of the rotation speed. A compromise is made between the counting time (i.e., the measurement rate) and the desired accuracy. The adaptation of the single-phase signal to the digital recording system is accomplished using digital transducers.

The transducers associated with rotation speed sensors consist of:

- circuits for impedance matching, amplification and shaping of the signal delivered by the sensors,
- a time base, usually consisting of a temperature-controlled master crystal together with a divider link and,
- a counter.

The digital transducers used are either of the frequencymeter or periodmeter type, depending on the pulse rate of the signal from the rotation speed sensor.

3.6.4.1. Frequencymeter

The time base provides equal time intervals T which are generally either 0.01 sec, 0.1 sec or 10 sec. The counter sums the number of periodic signal pulses transmitted by the rotation speed sensor and shaped during time intervals equal to T. Considering F as the signal frequency generated by the rotation speed sensor, the number n counted by the counter during a time interval T will be given by the formula:

$$n = F \times T$$

With an instrument of this type, the error in measuring the frequency F is:

$$\frac{\Delta F}{F} = \frac{\Delta n}{n} + \frac{\Delta T}{T}$$

Under conditions of no noise, the error introduced by the counter for determining n is at the most equal to one whereas the relative error of the time base $\frac{\Delta T}{T}$ is generally less than 10^{-5} . This error is negligible with respect to the accuracy generally required which is ± 0.15 percent hence:

$$\frac{\Delta F}{F} = \frac{1}{n} + 10^{-5} = \frac{1}{F \times T}$$

The measurement accuracy obtained with a frequencymeter is inversely proportional to the product of the frequency to be measured times the counting time. To reach the desired value of 0.15 percent, this product must be higher than 660. Consequently, such a device enables accurate measurements of slowly varying speeds to be made. This device, however, is not suited for the analysis of transient phenomena.

3.6.4.2 Periodmeter

To obviate the need for excessive counting time, it is advisable to perform low frequency measurements by means of transducers of the periodmeter type. The counter sums the number of pulses generated by the timer during the time interval between two pulses from the rotation speed sensor. Considering F as the frequency of the signal generated by the rotation speed sensor, the number n counted by the counter will be:

$$n = f \times \frac{1}{F}$$

The error introduced by a periodmeter into the measurement of frequency F is:

$$\frac{\Delta F}{F} = \frac{\Delta f}{f} + \frac{\Delta n}{n}$$

As for the frequencymeter measurements (assuming no noise), the error introduced by the counter for determining n is at most equal to one whereas the relative error $\frac{\Delta f}{f}$ is less than 10^{-5} , hence:

$$\frac{\Delta F}{F} = \frac{1}{n} + 10^{-5} = \frac{F}{f}$$

The periodometer measurement accuracy is better since the measured frequency is very much lower than the oscillator frequency (usually 100 kHz). Thus, to reach the desired accuracy of ± 0.15 percent, the measured frequency must be lower than 150 Hz. The major inconvenience encountered with periodometers is that the summed number n is inversely proportional to the frequency to be measured and that the latter must then be calculated by proceeding in the reverse order.

3.7 Transducers Compatible with Various Recording Techniques

Instead of using the devices described in paragraph 3.6.2 (through direct acquisition in digital form either from a computer, from a digital acquisition device, or by reconversion into three-phase signal), the three-phase signal may be converted into DC voltage proportional to the rotation speed. Such a device is referred to as a frequency-to-voltage converter. The resulting DC voltage can then be recorded on a photographic or magnetic tape recorder or telemetered. There seem to be no significant reasons for recording on an analog device, although this is practical.

The frequency-to-voltage conversion can be accomplished by either of two processes:

(1) Frequency-to-voltage converter including a diode pump (Figure 23). The input signal of frequency F is applied through capacitor c to the junction point of two diodes $D1$ and $D2$. The anode of diode $D1$ is at ground potential while the cathode of diode $D2$ is connected to the input of an operational amplifier whose negative feedback loop consists of a capacitor and resistor in parallel. When the input voltage is negative, capacitor c is charged across diode $D1$. When the input voltage is positive, capacitor c is discharged across diode $D2$ and generates a current I in opposition with current I' of the amplifier negative feedback loop. For each signal period, the potential stored in capacitor c corresponds to $Q = cV$, where V represents the charging voltage of capacitor c ; i.e., the peak-to-peak amplitude of the input signal. Hence:

Current I is equal to $c \times V \times F$

Current I' is equal to V_o/R (V_o being the output voltage of the operational amplifier), thus:

$$V_o/R = c V F.$$

The output voltage of the operational amplifier is $V_o = c R V F$; it is proportional to the input signal frequency F and to the capacitor charging voltage V . Therefore, the peak-to-peak voltage of the input signal must be constant and its leading and trailing edges free of distortion. This condition is achieved by the use of a shaping stage. Capacitor c' , connected in parallel with resistor R , is used for filtering and pulses during the operation.

(2) Frequency-to-voltage converter including a flip-flop (see diagram in Figure 24). The duration of the input signal, having a frequency F , is determined by a flip-flop circuit. The latter drives a switch consisting of two PNP and NPN type transistors, series-connected between the ground and a reference voltage V_{ref} . In the rest state, the flip-flop delivers an output signal which causes transistor 1 to conduct and to saturate whereas transistor 2 is blocked. Thus, no current flows through resistor R , one end of which is connected to the junction point of both transistors, and the other to the operational amplifier input. In working condition, the flip-flop output signal blocks transistor 1 and causes transistor 2 to conduct. The current I flowing then through resistor R is $I = V_{ref}/R$. If we consider t as being one state of the flip-flop, the charge applied across resistor R will be $Q = V_{ref} \times t/R$.

If F is the input signal frequency, the flip-flop will change its state F times per second and current I will correspond to $I = V_{ref} \times t/R \times F$.

This current is in opposition to the negative feedback loop current I' of the operational amplifier:

$$I' = \frac{V_o}{R} \quad \text{hence} \quad V_{ref} \times \frac{t}{R} \times F = \frac{V_o}{R}$$

Consequently, the output voltage V_o is proportional to frequency F of the signal whose frequency is to be measured.

Regardless of the process used, the output voltage V_o includes a DC component which is proportional to the frequency of the signal to be measured; i.e., to the rotation speed, and an AC component which must be suppressed by a filter. A compromise can be made between the permissible residual noise level in the output signal and bandwidth required for the transducer. The analog transducers are presently available with time constants of 65 percent less than 200 msec, with a residual voltage below 2 mV and an input signal frequency higher than 16 Hz.

3.8 Scale Expander

In order to improve the reading accuracy of the DC signal voltage, use can be made of a "coarse-fine" system. This system is designed to provide two output voltages; i.e.,

- (1) the "coarse" channel has provisions for impedance matching; however, the output voltage is identical to the input voltage;
- (2) the "fine" channel contains provisions for expanding the scale of the input; i.e., a change in voltage of zero to full scale at the input is represented by a selected number of zero to full scale voltage excursions at the output. For example, if an amplification factor of five was selected, then each successive 20 percent of full scale voltage change at the input would result in a zero to full scale voltage change the output (Figure 25). (Note: The fine voltage is equivalent to the sensitive sweeps of the P51 tachometer.)

A tachometer transducer of this type, referred to as P6200 (Figure 26), has been developed at the Centre d'Essais en Vol. The "coarse-fine" system includes up to 5 sensitivities which make it possible to obtain an overall system accuracy of up to ±0.30 percent in recording or telemetry systems. The advantage of this tachometer is essentially its high rate; the system time constant is less than 200 msec which corresponds to a response time at 5 percent of about 1 sec (Figure 27). The P62 transducer is mounted between the three-phase/single-phase conversion system and a recording of telemetry system (Figure 28). The P62 transducer requires a 28V DC power supply and its consumption is less than 450 mA.

4.0 MAGNETIC SENSORS

At the present time, tachogenerators are used almost exclusively for rotation speed measurements; however, new techniques employing magnetic sensors are being introduced in flight test programs.

4.1 General

There are three types of magnetic sensors usable for engine tests: proximity detectors, phonic wheels, and mobile permanent magnets associated with a fixed coil.

4.1.1 Proximity Detectors

This type of detector incorporates an oscillator consisting of two tuned circuits. One of these circuits, making up the detector proper, is fitted with a detector coil. The alternating current supplied to this coil produces induction flux lines which generate eddy-currents on any metallic surface which is sufficiently close. The eddy-currents in turn produce a magnetic field which counteracts the initial magnetic field and tends to decrease the current flowing through the coil. If the metallic surface is close to the sensor, the eddy-currents are high whereas the current in the coil is low. This circuit then becomes untuned with respect to the second tank circuit and the oscillation ceases. If the metallic surface is away from the sensor, the eddy-currents are low while the current in the coil is high. This corresponds to a tuned condition of both tuned circuits.

Each time the auxiliary cog wheel, used for the rotation speed measurement, is moved by one cog, these sensors act as successively open or closed mechanical contacts; the closing (or opening) frequency of the contacts is proportional to the number of cogs per unit time and hence to the rotation speed of the auxiliary wheel. The modulation frequency is $F = k \times N/60$ where N is the rotation speed in terms of rpm, and K the number of cogs of the auxiliary wheel.

4.1.2 Magnetic Sensors Referred to as "Phonic Wheel" (Figures 29 and 30)

The magnetic flux variations caused by the displacement of a cog wheel or turbine blades within a magnetic field can be used to generate signals whose frequency is proportional to the rotation speed (the blades or cogs must be made of magnetic metal). This type of tachometer can be compared to a small multiple pole alternator. The magnetic circuit consists of two soft iron cores interlinked by a magnet and an auxiliary cog wheel integral with the motion. Each time a cog of the wheel, called "Phonic Wheel", moves in front of the soft iron cores, a flux variation occurs in the windings of two coils which are concentrically arranged about the core; these coils are electrically wired in series. The frequency of the emf induced in the coils is proportional to the rotation speed of the auxiliary cog wheel and the number of cogs; i.e., $F = N/60 \times n$.

4.1.3 Mobile Permanent Magnet Associated with a Fixed Coil

The permanent magnet is fitted to a blade of the turbine whose rotation speed is to be measured. The turbine blades must be made of magnetic metal and the turbine itself must be dynamically balanced. At each revolution of the turbine, the magnet induces in the coil two pulses having opposed polarities. To ensure that the signal induced in the coil is a sine wave, the following conditions must be fulfilled:

- (1) either several magnets should be distributed over the turbine blades (the blades are generally fitted with two diametrically opposed magnets),
- (2) or the rotation speed should be relatively high (as in the case of expansion turbines). The magnets as well as the coil location must be provided for in the original design.

Note: Instead of the rotation speed sensor coils described in the two preceding paragraphs (Phonic Wheel and mobile permanent magnet associated with a fixed coil), it is possible to install magnetoresistors (these are semi-conductor devices whose resistance increases when placed within a magnetic field). The magnetoresistor-type instruments develop forces acting upon the rotating element, which are smaller than those generated by coil-type instruments. They are particularly well suited for measuring the rotation speed of spinnars used in flow detectors which convert the flow parameter into rotation speed measurement.

4.2 Design of an Airborne Measuring System

4.2.1 Direct Installation of the System on the Engine Without Drive

Since part of the engine is used as a part of the magnetic sensor, the sensor is normally made integral with the engine. Therefore, provisions should be made for this when the engine is designed. However, the magnetic sensor may be added later using an auxiliary cog wheel. This solution is not recommended because the resulting signal shows a tendency to be more affected by noise. The first two types of magnetic sensors described presuppose the presence of metal blades and correspond to engine rotation speed measurements originating from the compressor blades. The third type is used with non-magnetic blades. It corresponds to the rotation speed measurement of expansion turbines.

4.2.2 Installation Using a Shaft Drive

Self-contained magnetic sensors are available which include a cog wheel and a phonic wheel-type sensor housed in a case of approximately the same size as that of a tachogenerator. Such a sensor is installed on the shaft drive and is separate from the engine. This type of installation is rarely used, although the resulting signal is less affected by noise than in the case of a magnetic sensor integral with the engine. In fact, this solution is not as attractive as the conventional tachogenerator since it requires one shaft drive for two generators (or may even require two shaft drives) due to the fact that the signal from the magnetic sensors cannot be displayed on a standard aircraft indicator. Thus, it is necessary to provide a specific shaft drive in addition to that used for the aircraft generator.

4.2.3 Measurement Recording

The frequency of the signal developed by a magnetic sensor is generally between 1,000 Hz and 15,000 Hz. In some applications it may reach 35,000 Hz; this is the case for rotation speed measurements using certain types of torquemeters for which the magnitude of the torque is proportional to a differential rotation speed.

The recording of a signal generated by a magnetic sensor does not cause any problems, even if the sensor is not specifically intended for rpm recording, provided, however, that the impedances of the measuring instruments involved are high enough. This recording can be accomplished using any of the recording facilities normally used in flight tests. Before the recording takes place, it is also possible to transmit the data via a telemetry system. The following signal conditioning devices are required:

- either analog: of the frequency-to-voltage converter type P62 described in paragraph 3.8,
- or digital: essentially provided for impedance matching and signal shaping, they belong to the digital system used for the overall data acquisition (such devices are accommodated in the DAMIEN system of JAGUAR aircraft for the acquisition of rpm measurement from P55 airborne indicators).

Figure 31 shows the general layout of the various recording processes of rotation speed measurements using a magnetic sensor.

4.3 Advantages and Disadvantages

Magnetic sensors offer the significant advantage of smaller size and weight, and the stress imposed upon the rotating shaft, is low (the repelling power is less than 10^{-6} Newtons). The effects of environmental conditions (temperature, acceleration, vibration) are almost negligible. In addition, the sensors may be remotely installed from the associated electronic system without compromising the measurement accuracy. They are capable of operation under extremely severe ambient conditions: temperature (-40°C to $+450^{\circ}\text{C}$), immersion into lubricating oil at a pressure of about 6 kg/m^2 .

Nevertheless, the magnetic sensors do have certain limitations:

- (1) With regard to the spacing between the detection coil and the wheel cogs or turbine blades: the minimum detection distance depends upon the nature of the metal. This minimum spacing is inversely proportional to frequency F .
- (2) The permissible off-settings have very close tolerances and are inversely proportional to frequency F .
- (3) The cog and blade dimensions are restricted to minimum values.
- (4) The thickness of the cog wheel is limited.
- (5) The maximum frequency F is usually limited to 2,000 Hz (5,000 Hz for some manufacturers).

For reference purposes, the cog-to-detector spacing must be of about 1 mm with permissible off-settings of ± 0.2 mm for steel cogs and a modulation frequency lower than 500 Hz. If the modulation frequency is higher, the permissible off-setting tolerance becomes ± 0.05 mm. The cog must be 2 mm wide when the depth is 4 mm and their spacing is 5 mm.

4.4 Existing Equipment

The application of magnetic sensors as rotation speed detectors in the field of regulation controls is becoming common practice. To this end, steps have been taken to initiate development of a magnetic sensor whose overall dimensions are 50 x 38 x 30 mm; other characteristics include: high resistance to vibration, hermetically sealed, unaffected by lubricants, hydraulic fluids and fuels, satisfactory operation at temperatures of 350°C for the sensor and 450° for the cables.

Magnetic sensors are also used for torque measurements (the torque value being derived from rotation speed measurements), for flow measurements and vibration measurements made on the first stage blades of compressors (in that case the rotation speed parameter appears in the vibration frequencies as a spurious carrier).

It is also to be noted that the engine manufacturers have started using the magnetic sensors for in-flight engine tests.

4.5 Power Supply

Magnetic sensors require a power supply but the power consumption is low.

5.0 COMPARISON OF THE THREE PREVIOUSLY DESCRIBED SPEED MEASUREMENT TECHNIQUES

The three rotation speed measurement processes discussed in this AGARDograph; i.e., chronotachometers, tachogenerators and magnetic sensors have been successfully applied in flight tests. At present, they are all three used for rpm measurements and their coexistence can be explained on the basis of the diversity of problems encountered in their application.

The chronotachometers are simple, accurate and do not require external power. They are appropriate for stabilized rpm measurements and are suitable to the rpm measurements on small private airplanes. Except for the fact that the corresponding recording system requires a power supply, their characteristics are similar. Both of them are subject to the limitations inherent to the transmission of motion through a flexible shaft.

The systems fitted with tachogenerators allow an electrical transmission of the signals. Although these systems have recently been miniaturized, they are still relatively bulky. They do not require external power and a recorder can be connected either in parallel with the generator or to a separate recording output provided on the aircraft indicator, or to an additional generator if a shaft drive is available. Furthermore, the recent development of frequency-to-voltage converters with low time constants allows variable rotation speed measurements to be made from the signals delivered by the tachogenerators.

Magnetic sensors are considerably smaller and lighter than tachogenerators for equivalent range and accuracy. The magnetic sensors may be used in cases where, due to sensor dimensions and temperature considerations, the installation of a tachogenerator would not be feasible. Their use, however, remains limited because of the extremely severe mechanical tolerances associated with these devices.

It is to be noted that the aircraft system plays an important role in the selection of the measuring system. If an aircraft is equipped with magnetic sensors, for regulation purposes or other applications, the simplest solution is to obtain the measurement through parallel-connection with these magnetic sensors instead of installing an additional tachogenerator. On the other hand, if the magnetic sensor has not been supplied by the engine manufacturer, the problems of noise which are liable to be encountered if the mechanical tolerances are exceeded renders the installation of this type of system inappropriate. Therefore, a tachogenerator should be installed, whenever possible. The question is whether the tachogenerators will be gradually replaced by the magnetic sensors. The answer cannot be given yet and will probably depend upon the technical improvements to be achieved in the production of magnetic sensors.

6.0 CALIBRATION OF ROTATION SPEED MEASUREMENT SYSTEMS

The chronotachometers must be calibrated prior to use. A typical calibration facility includes a series-wound motor whose speed can be adjusted to desired values to an accuracy of about ± 3 rpm. Typically, the torque available on the motor is 0.4 MN during the ten seconds following the starting and 0.2 MN in continuous service (see Figure 32).

The tachogenerators do not require calibration due to their principle of operation, whereas the associated eddy-current indicators and similar devices are usually calibrated using a tachogenerator driven by a motor whose speed is adjustable and known. The calibration of the electronic devices used for frequency-to-voltage conversion is accomplished using a sine wave voltage generator controlled by a frequencymeter. The digital devices do not require calibration.

The magnetic sensors do not require calibration, whereas their associated electronic devices (frequency-to-voltage converters and digital converters), which are similar to the devices used with tachogenerators, are calibrated using the procedure stated in the above paragraph.

APPENDIX

1.0 ROTATION SPEED MEASURING DEVICES FORMERLY USED ON AIRCRAFT1.1 Centrifugal Tachometer

The centrifugal force f' acting upon a weight m integral with a rotating shaft is proportional to the square of the rotation speed of that shaft, hence:

$$f' = m\omega^2 r.$$

In this formula, m represents a punctual weight integral with the rotating shaft. Under the action of a compressed spring force, this weight comes to a balance position at a distance r from the shaft axis. WATT's ball regulator, one the major applications of this property, has been used on aircraft for speed regulation purposes. It should be remembered that a WATT's regulator consists of a centering device accommodating two hinged levers and two balls (weight m) whose balance position is transmitted to a sliding sleeve by means of two additional hinged levers.

1.2 DC Generators

Such devices generally consist of a small magneto including commutators or of an alternator-rectifier assembly. They deliver a DC voltage proportional to the rotation speed. The DC generators are rarely used because of numerous disadvantages; i.e.:

- The residual ripple voltage, superimposed upon the DC voltage proportional to the rotation speed may, in the case of magnetos, be reduced by increasing the number of commutator bars; however, this complicates the design.

- The load impedance of the voltmeters associated with these generators must be high compared to the line resistance.

- The induced emf tends to vary in time and as a function of temperature due to the magnetic field variation of the permanent magnets.

- In addition, the magnetos fitted with commutators raise problems inherent to brush wear as well as defective electrical contacts at low atmospheric pressure and high temperature conditions.

2.0 OTHER ROTATION SPEED MEASURING TECHNIQUES NOT YET USED FOR AIRBORNE APPLICATIONS

In this paragraph, attention is invited to optical sensors which use optical fibers. An optical fiber is made up of a large number of very thin fibers (in the order of a micron) grouped within a cylindrical tube of 3mm diameter for instance. One-half of the fibers carries the light from a light source while the other half carries light reflected from and modulated by a device mounted on the member whose rotation speed is to be measured. The optical fibers produced in France withstand temperatures of 300°C, while a number of US manufacturers advertise products which can function at up to 700°C.

In the future, we may witness a competition between the optical fibers and photocells, on the one hand, and magnetic sensors on the other hand, for the rotation speed measurements. It should be noted that the photodiode time constant limits the range of optical sensors; however, they do not derive any energy from the rotating shaft; furthermore, and owing to the optical fibers, they are compatible with the various metals used for the construction of blades (magnetic and non magnetic), and they may be ideal when the space available in the proximity of the rotating shaft is very confined or under high temperatures.

REFERENCES

1. BNAe Standards.
2. Akeley, L.T., and Frazier, J.J., "Temperature Errors in an RPM Indicator With Magnetic Drive", Proceedings of the AIEE.
3. Anon. "Aircraft Electrical Tachometer Equipped With a GE Electrical Transmission", General Electric Co. Handbook GE1215.
4. Lutz, O., "Digitaler Geber für Drehzahlmessungen", DFVLR, Institut für Strahlentriebe.
5. "A Tachometer and Synchroscope for Reciprocating Engine Aircraft". Proceeding of IEE International Convention, March 1964.
6. Sevestre and Bailhache, "Speed Measurement", Techniques de l'Ingénieur vol no. R 1810.
7. Holz, "The Energization of Turbocompressor Blades", SNECMA.
8. Anon, MIL Specification I 7069, 29 December 1950.
9. Sevestre and Bailhache, R 1810 Techniques de l'Ingénieur Mesures et contrôle.

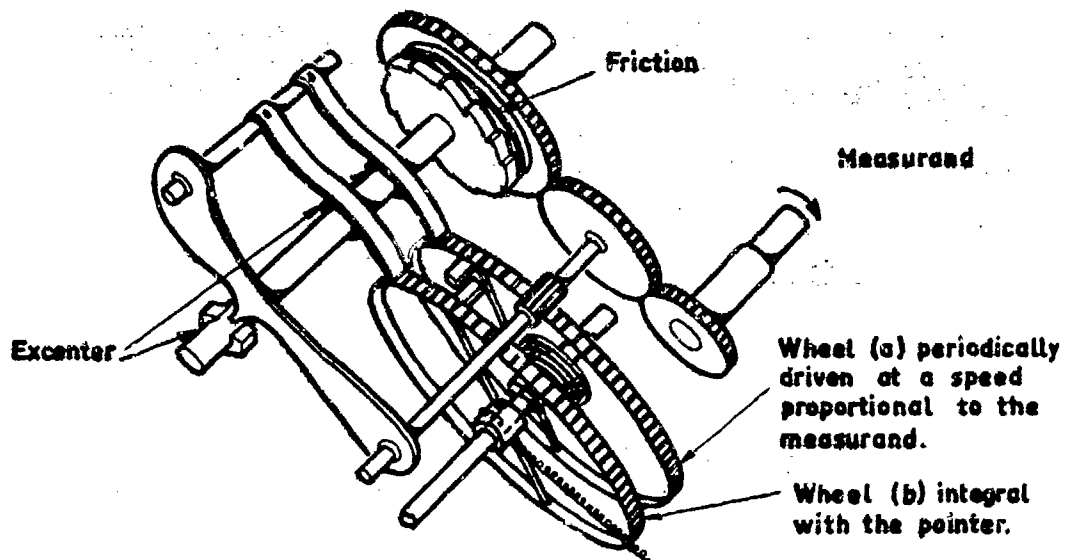

Fig.1 Diagram of a chronotachometer mechanism

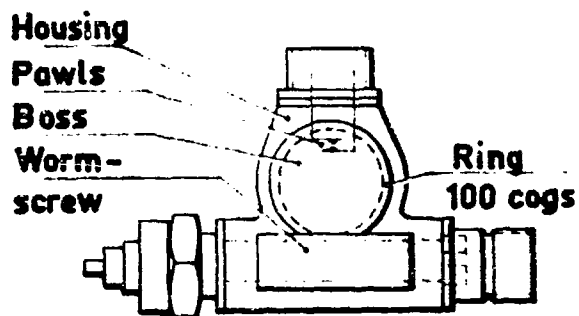

Fig.2 Schematic diagram of time pulser P 1000

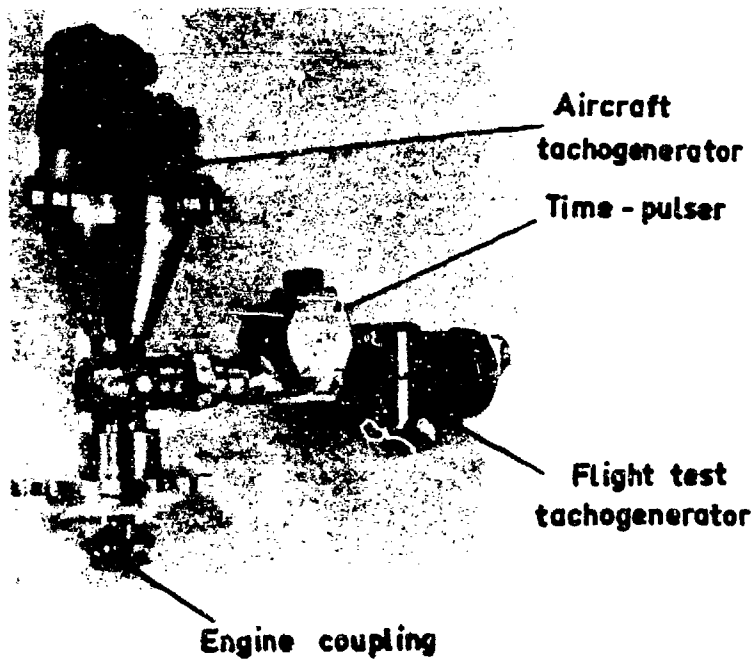

Fig.3 Mounting for the coupling of a time pulser and a tachogenerator to an engine

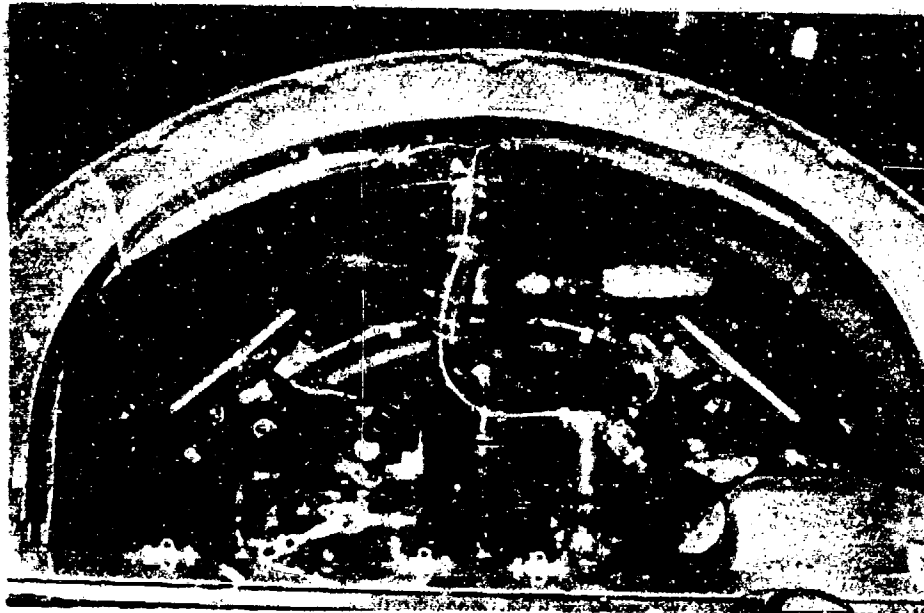

Fig. 4 Installation of the tachogenerator device shown in Fig. 3

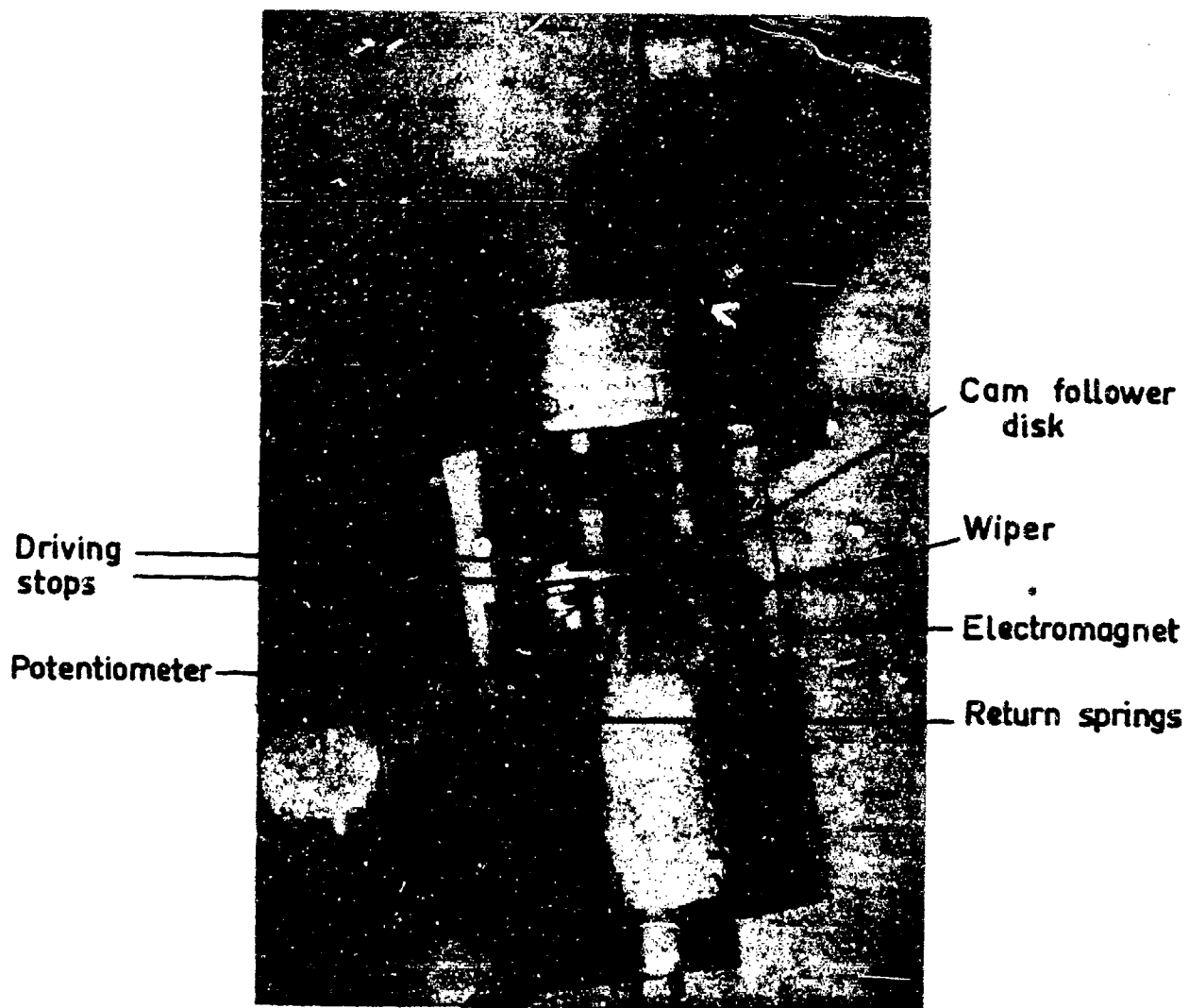

Fig. 5 Measurement of average r.p.m. with a potentiometer

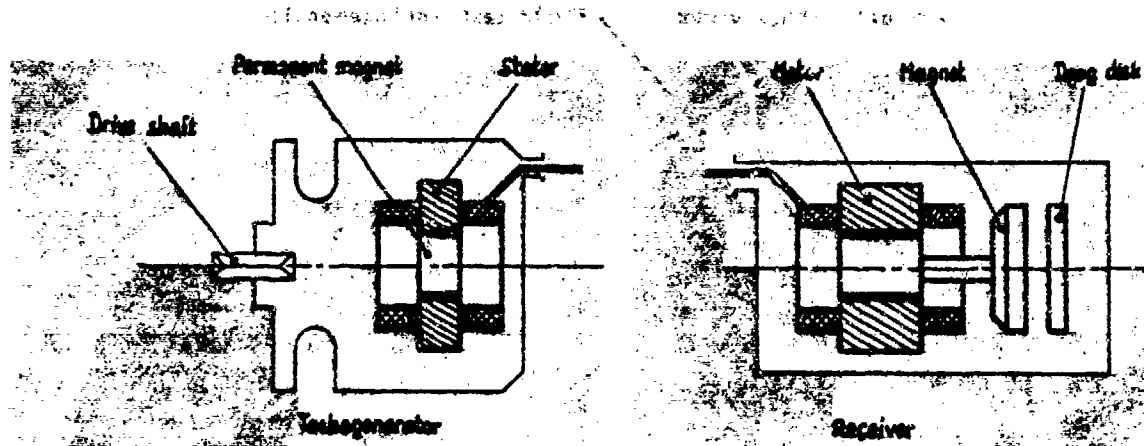

Fig.6 Diagram of a measuring system with a tachogenerator

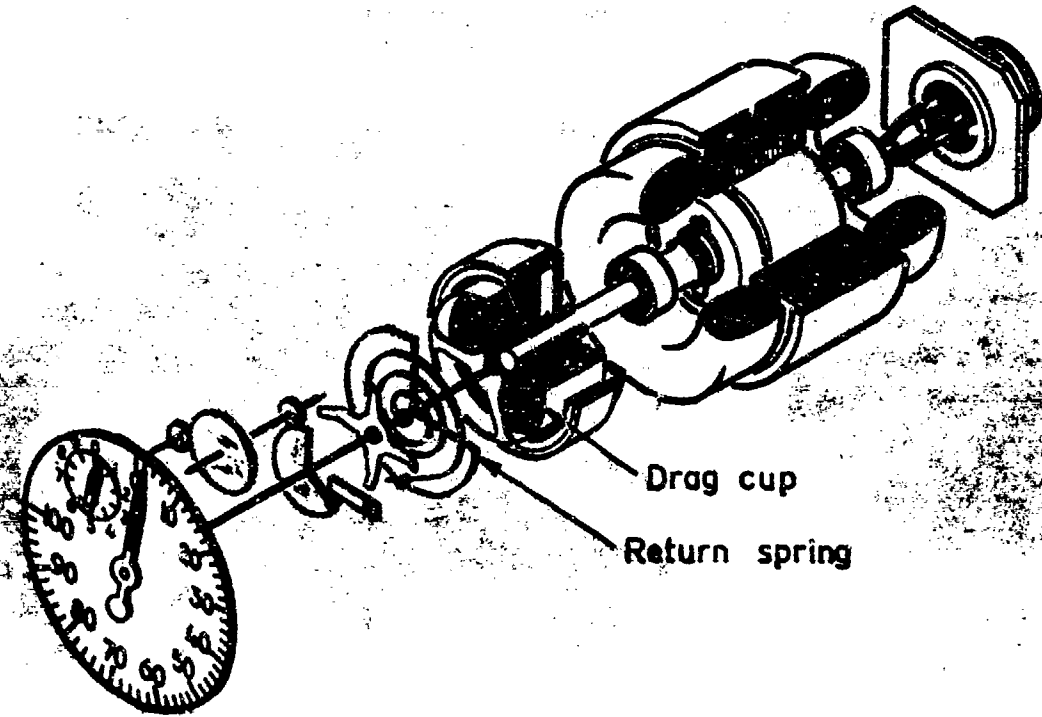

Fig.7 Diagram of an eddy-current tachometer

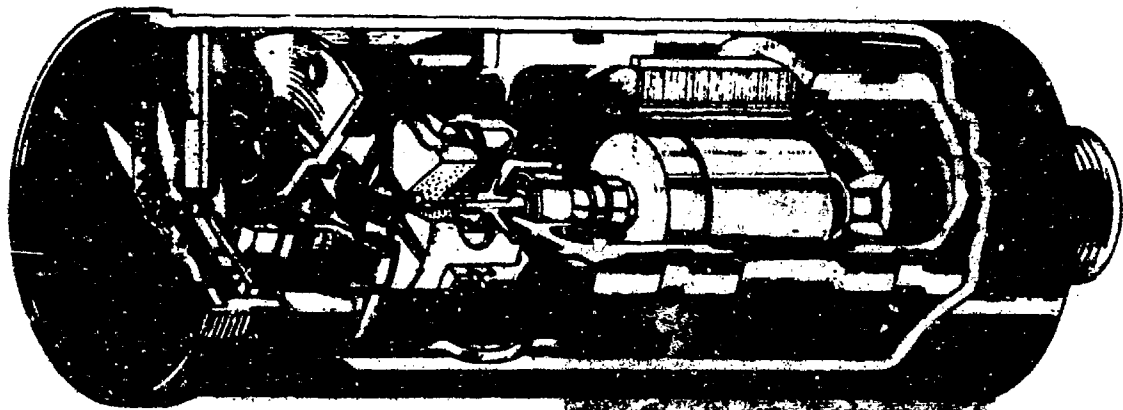

Fig.8 Cut-away view of an airborne eddy current tachometer

Aircraft tachogenerator Flight test tachogenerator

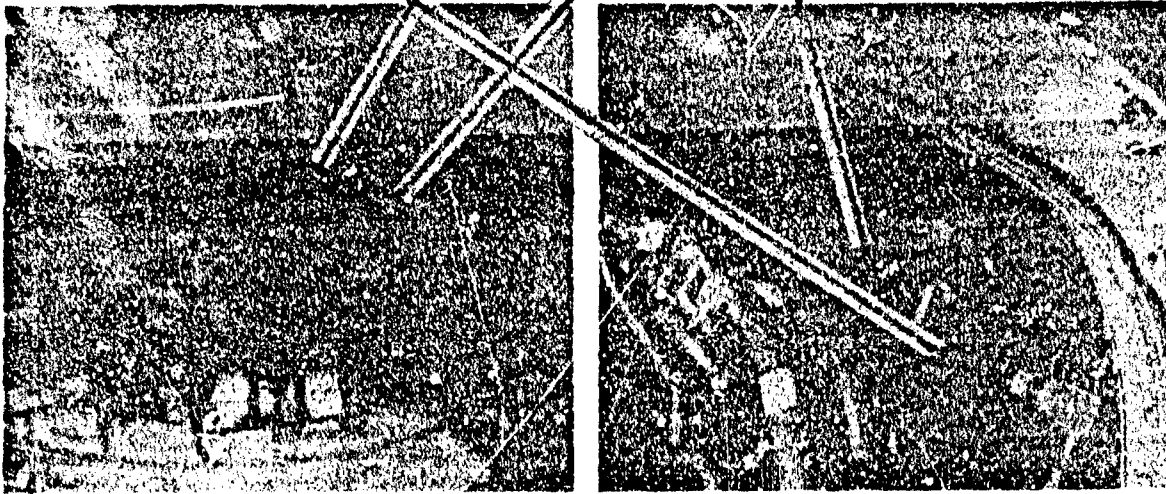

Fig.9 Installation of aircraft and flight test tachogenerators on an engine equipped with two power take offs

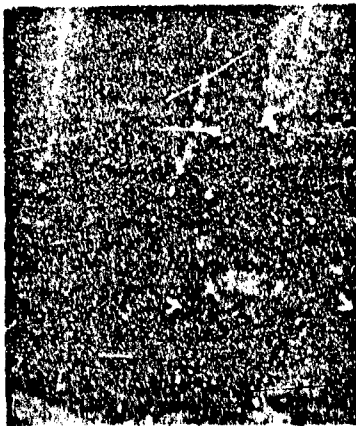

Fig.10 Helicopter installation of 4 tachogenerators on one power take-off



Fig.11 Tachogenerator driven through a flexible shaft



The tachogenerator has been connected directly to the power take off instead of to the flexible shaft

Flexible shaft

Fig.12 Measurement of rotor speed on an autogyro



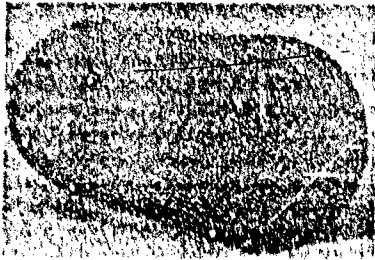

1. Single indicator P 5500

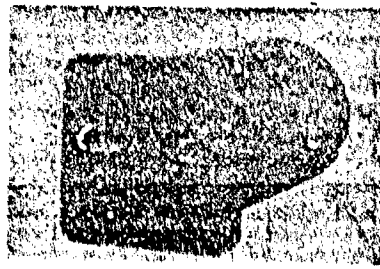

2. Dual indicator P 5502

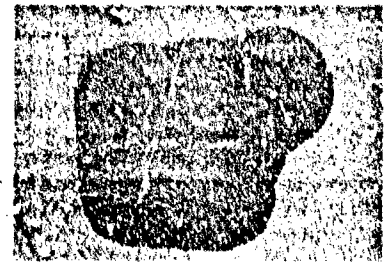

3. Triple indicator P 5503

Fig.13 Miniature tachometers

Speed recording device
Schematic diagram

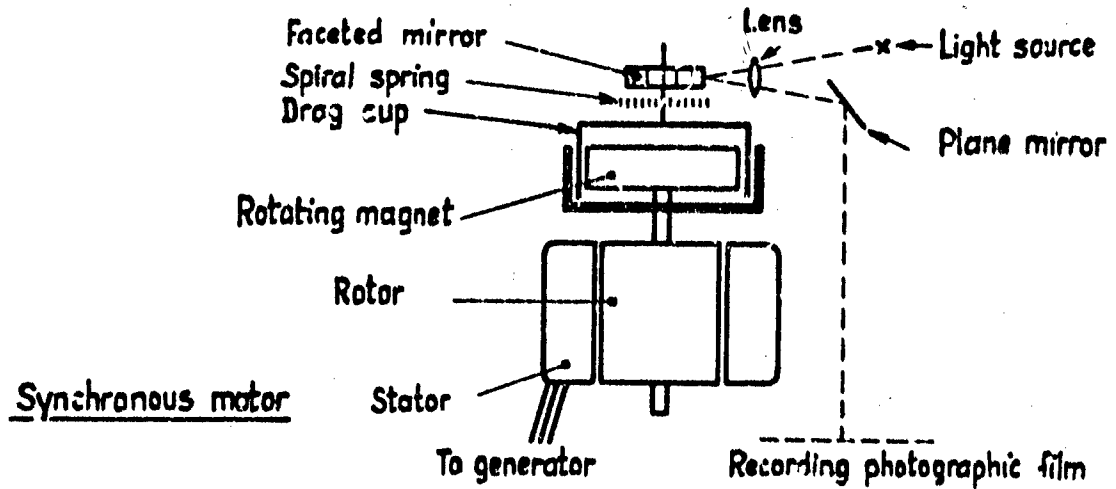

Fig.14(a) Schematic diagram of the P51 tachometer

1	Synchronous motor
2	Rotating magnet
3	Drag cup
4	Spring
5	Moving mirror
6	Lens
7	Fixed mirror
8	Adjusting screw

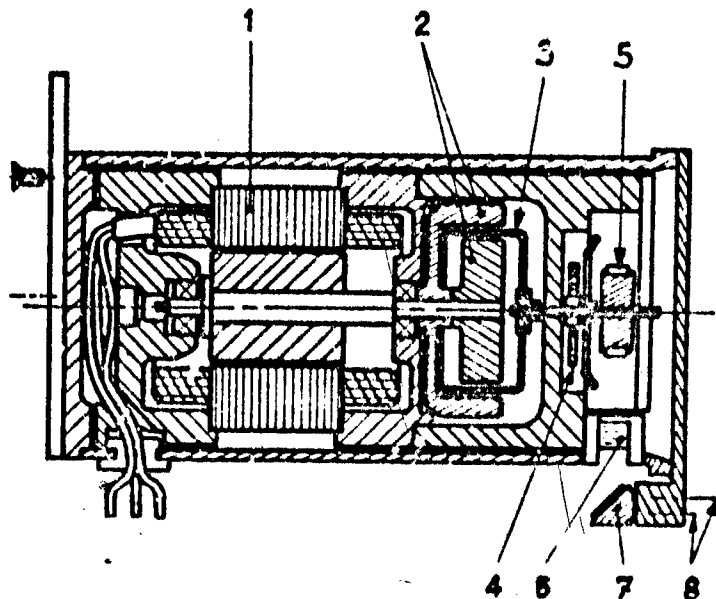

Fig.14(b) Cross section of a P51 tachometer

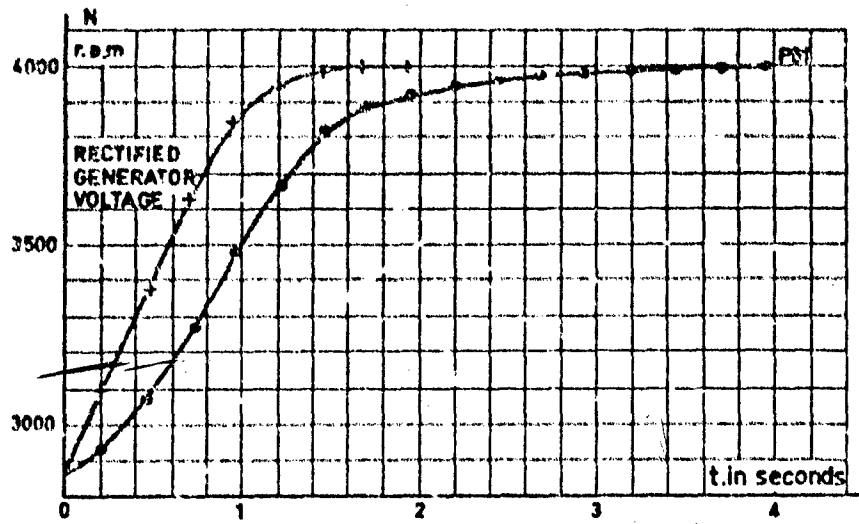

Fig.15 Response of a P51 to a rapid speed variation

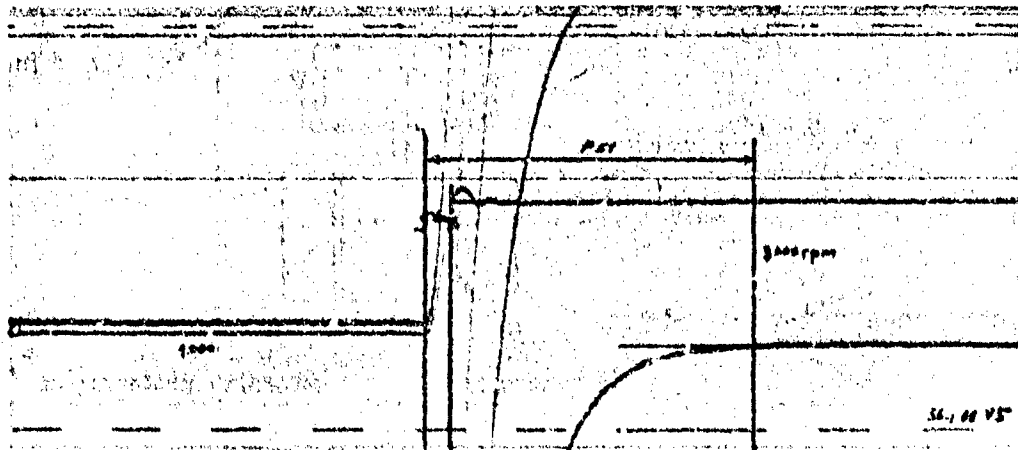

Fig.16 Recording of the response of a P51 tachometer to a rapid speed variation

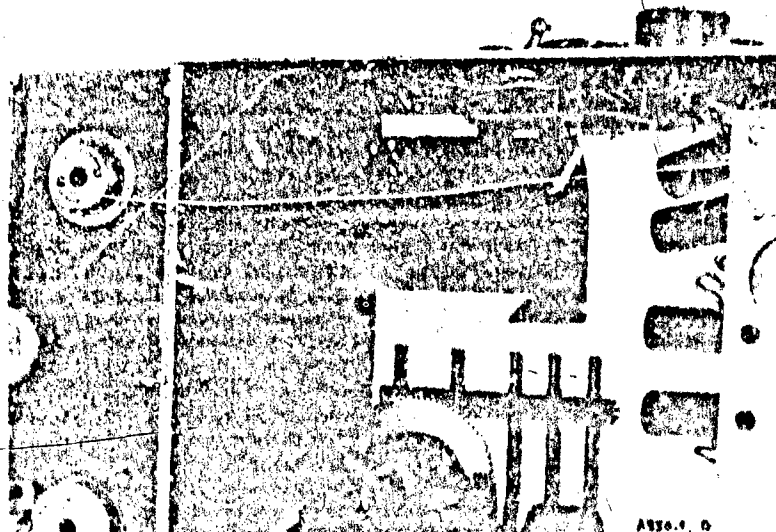

Fig.17 Photograph of a P51 tachometer in an A13 photographic recorder

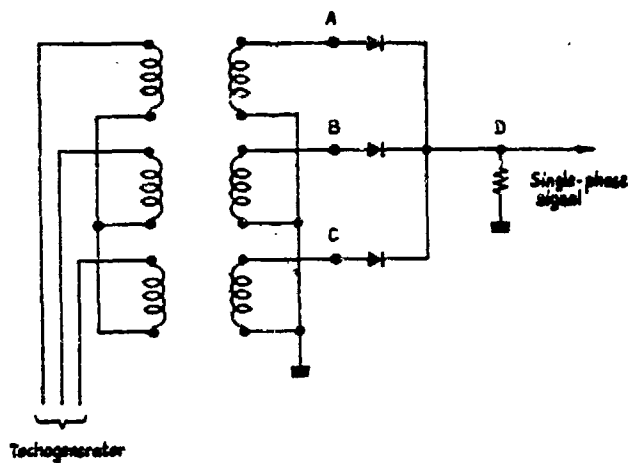

Fig.18 Schematic diagram of a frequency multiplier

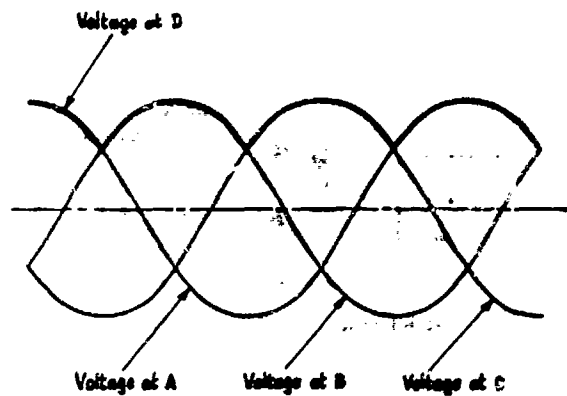

Fig.19 Voltages obtained at terminals A,B,C and D of the diagram in Fig.18

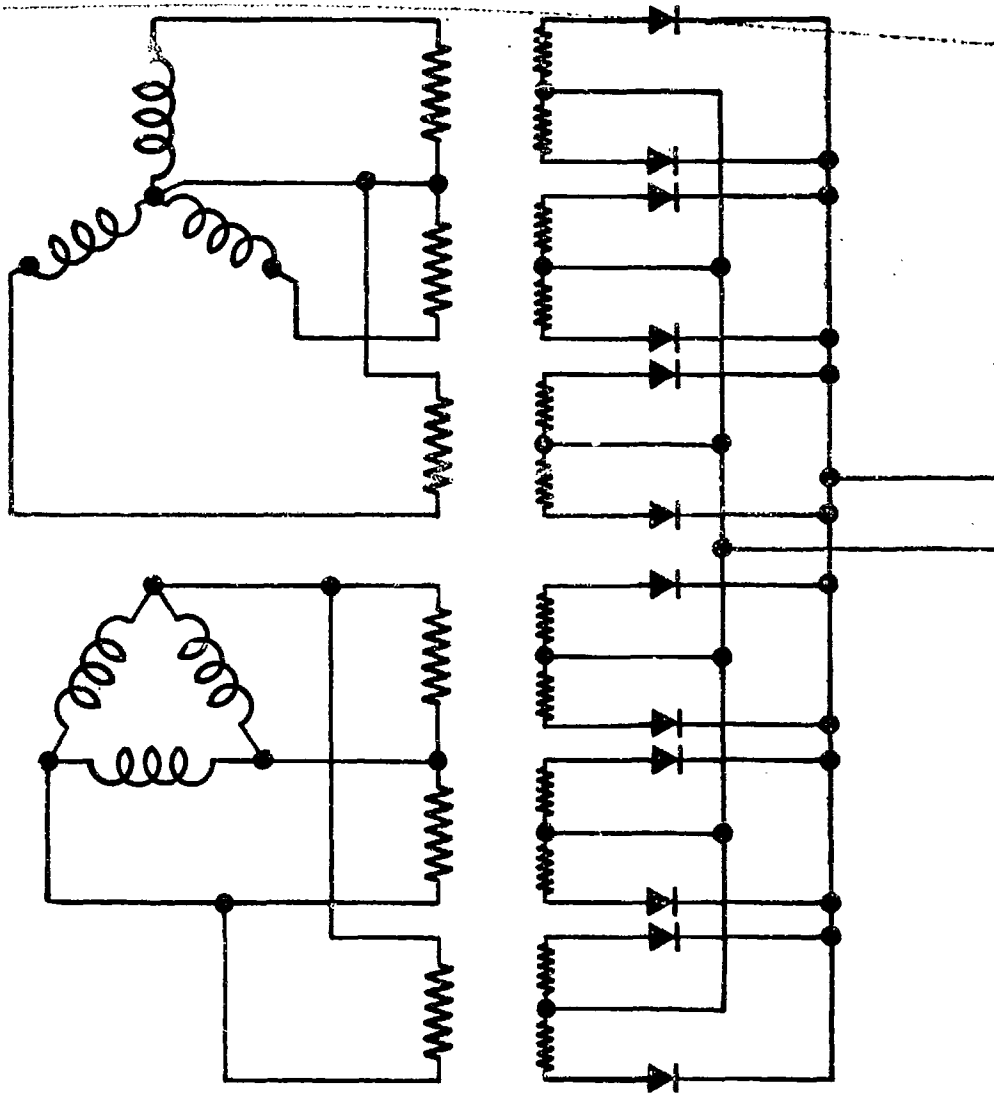

Fig.20 Schematic diagram of a twelve phase system

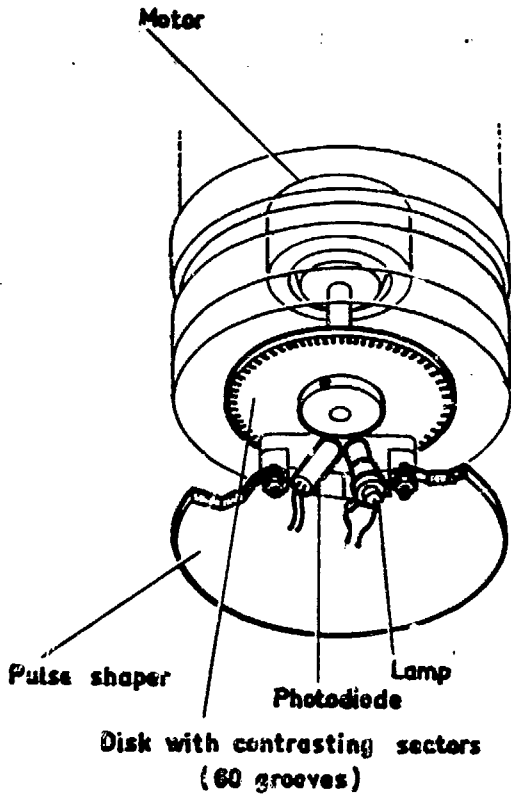
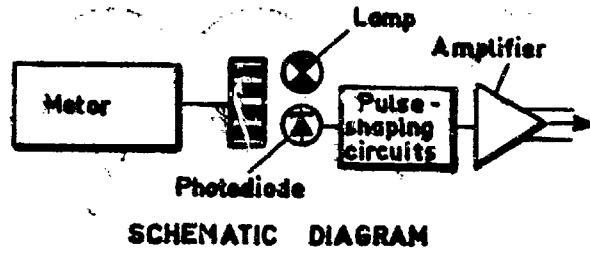

Fig.21 Schematic representation and diagram of the pulse emitter of a P55 tachometer

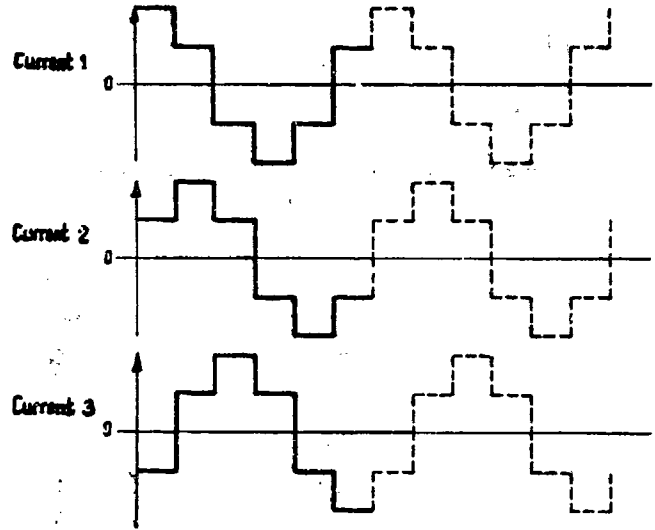
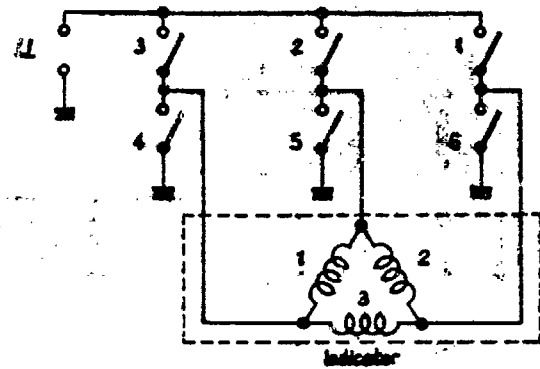

Fig.22 Recovery of a three-phase signal from a single-phase signal

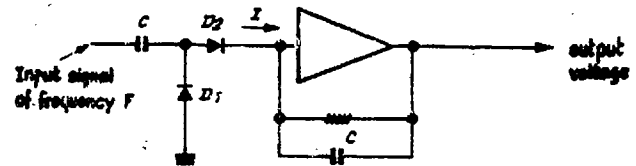

Fig.23 Frequency to voltage conversion using a diode pump

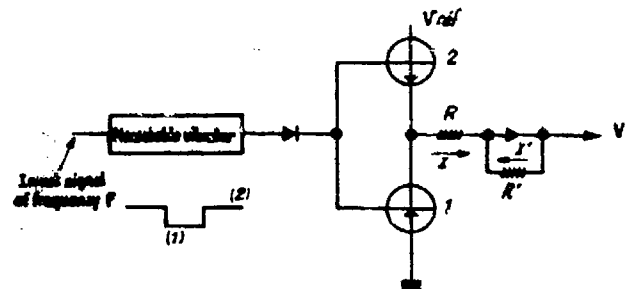

Fig.24 Frequency to voltage conversion using a single vibrator

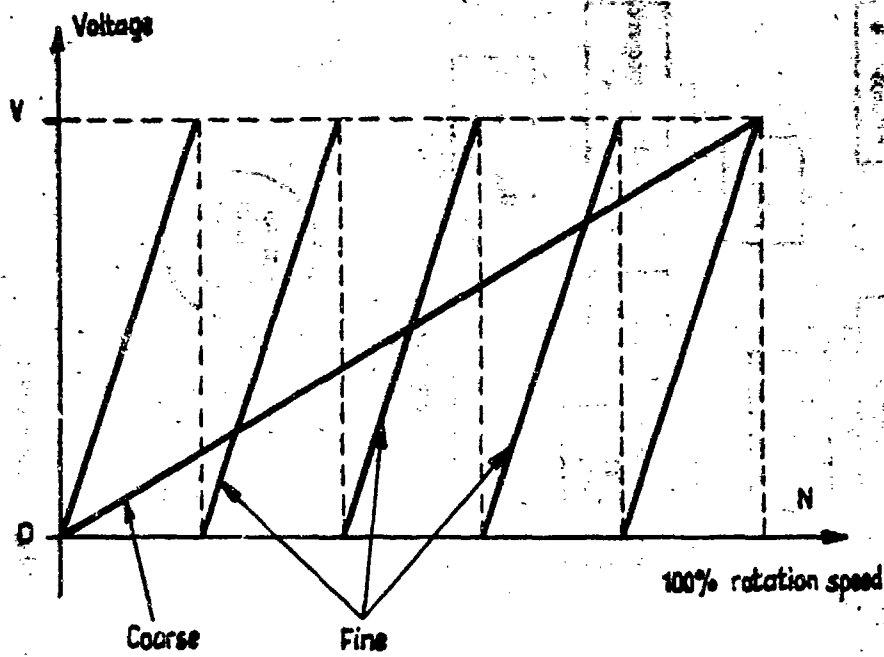

Fig.25 Coarse-fine recording



Fig.26 Photograph of a P6200



1

2

3

- 1_1000 Hz step input
- 2_5000 Hz " "
- 3_10 000 Hz " "

Fig.27 Recording of a P6200 transducer response to step inputs

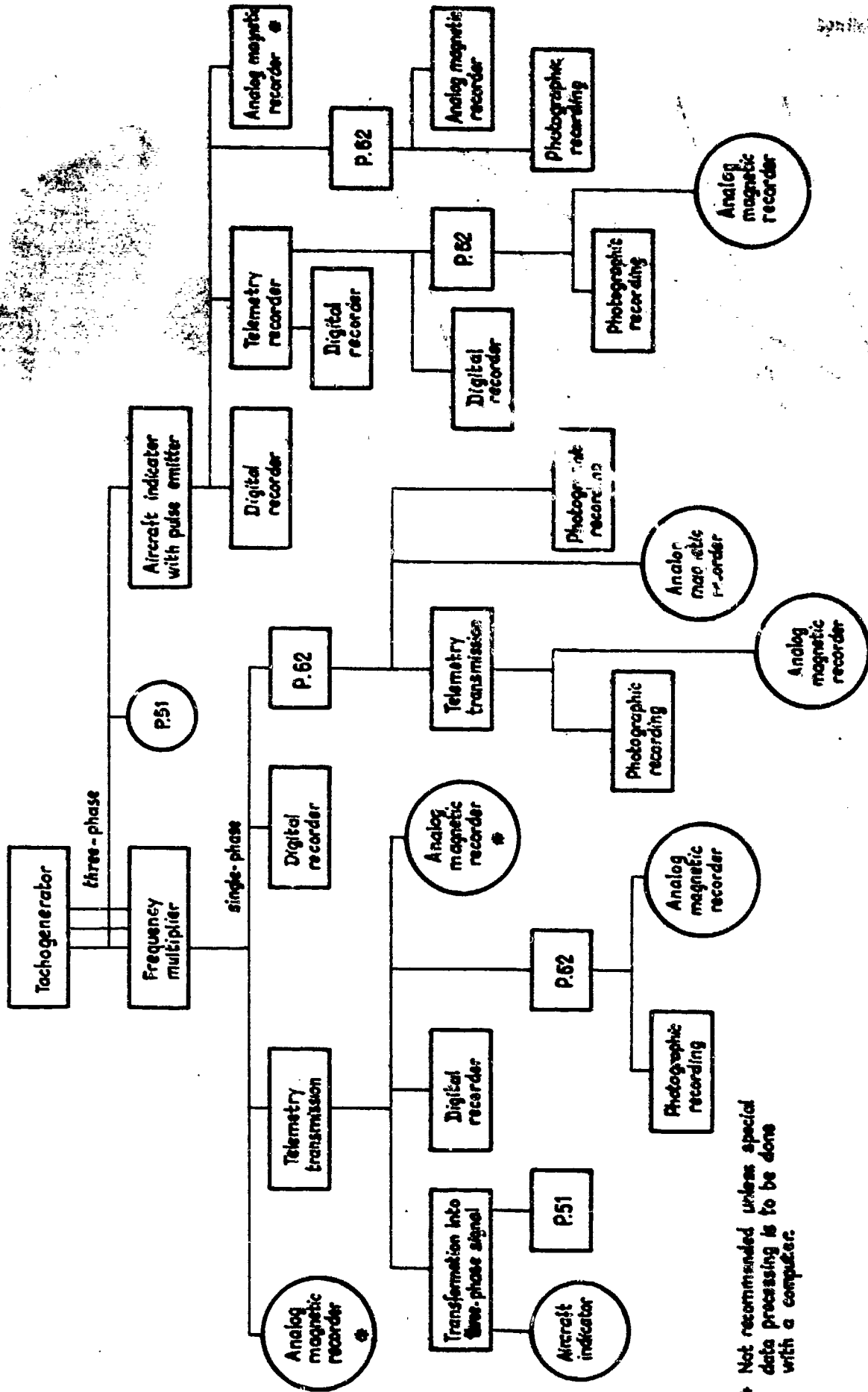

* Not recommended unless special data processing is to be done with a computer.

Fig.28 Block diagram tachograph system configurations for recording rotation speeds using a tachogenerator

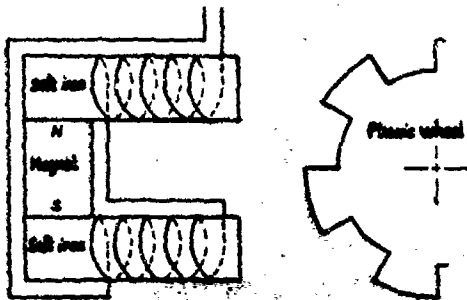
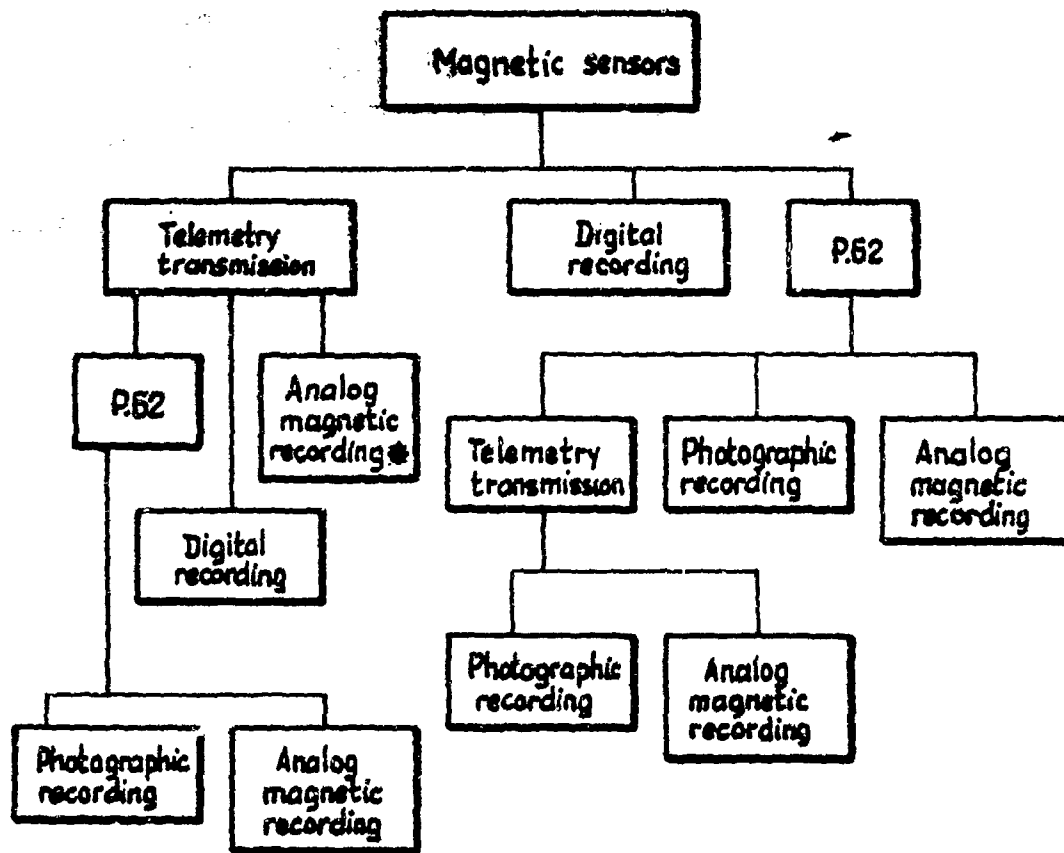

Fig.29 Schematic diagram of a phonic wheel magnetic sensor



Fig.30 Photograph of an r.p.m. phonic wheel sensor intended for the M.53 jet engine



* Not recommended unless special data processing is to be done with a computer.

Fig.31 Block diagram summarizing configurations using magnetic sensors for recording r.p.m.



Fig.32 r.p.m calibration stand

Reproduced from
best available copy.