

AD-772 977

THE EFFECTS OF SAND PARTICLES ON
SMALL, INTRICATE MECHANICAL COMPONENTS

Donald R. Artis, Jr.

Army Air Mobility Research and Development
Laboratory
Fort Eustis, Virginia

October 1973

DISTRIBUTED BY:

NTIS

National Technical Information Service
U. S. DEPARTMENT OF COMMERCE
5285 Port Royal Road, Springfield Va. 22151

DISCLAIMERS

The findings in this report are not to be construed as an official Department of the Army position unless so designated by other authorized documents.

When Government drawings, specifications, or other data are used for any purpose other than in connection with a definitely related Government procurement operation, the United States Government thereby incurs no responsibility nor any obligation whatsoever; and the fact that the Government may have formulated, furnished, or in any way supplied the said drawings, specifications, or other data is not to be regarded by implication or otherwise as in any manner licensing the holder or any other person or corporation, or conveying any rights or permission, to manufacture, use, or sell any patented invention that may in any way be related thereto.

Trade names cited in this report do not constitute an official endorsement or approval of the use of such commercial hardware or software.

DISPOSITION INSTRUCTIONS

Destroy this report when no longer needed. Do not return it to the originator.

ACCESSION FOR	
WTS	White Section <input checked="" type="checkbox"/>
DC	Buff Section <input type="checkbox"/>
UNANNOUNCED	<input type="checkbox"/>
JUSTIFICATION.....	
BY.....	
DISTRIBUTION/AVAILABILITY CODES	
Dist.	AVAIL. a/d/or SF. JNL
A	

ic

14. KEY WORDS	LINK A		LINK B		LINK C	
	ROLE	WT	ROLE	WT	ROLE	WT
Sand Dust Binding Circuit Breakers Mechanical Component Qualification Test AH-1G Silica Flour Hermetic Sealing Military Standard 810						

ib

UNCLASSIFIED
Security Classification

AD 772 977

DOCUMENT CONTROL DATA - R & D		
<i>(Security classification of title, body of abstract and indexing annotation must be entered when the overall report is classified)</i>		
1. ORIGINATING ACTIVITY (Corporate author) Eustis Directorate U.S. Army Air Mobility Research & Development Laboratory Fort Eustis, Virginia		2a. REPORT SECURITY CLASSIFICATION Unclassified
		2b. GROUP
3. REPORT TITLE THE EFFECTS OF SAND PARTICLES ON SMALL, INTRICATE MECHANICAL COMPONENTS		
4. DESCRIPTIVE NOTES (Type of report and inclusive dates)		
5. AUTHOR(S) (First name, middle initial, last name) Donald R. Artis, Jr.		
6. REPORT DATE October 1973	7a. TOTAL NO. OF PAGES 145/151	7b. NO. OF REFS 8
8a. CONTRACT OR GRANT NO.	8b. ORIGINATOR'S REPORT NUMBER(S) USAAMRDL Technical Report 73-93	
a. PROJECT NO. Task 1F162205A11906		
c. House Task RM 70-13	8c. OTHER REPORT NO(S) (Any other numbers that may be assigned this report)	
10. DISTRIBUTION STATEMENT Approved for public release; distribution unlimited.		
11. SUPPLEMENTARY NOTES	12. SPONSORING MILITARY ACTIVITY Eustis Directorate U.S. Army Air Mobility R&D Laboratory Fort Eustis, Virginia	
13. ABSTRACT <p>This report presents the results of a series of tests conducted to investigate the failure mode of binding caused by sand particles in small, intricate mechanical components. These tests were prompted by the large number of failures of components where the suspected mode of failure was binding caused by sand ingestion. The armament system circuit breaker of the AH-1G helicopter was selected as the device to be tested.</p> <p>Tests were conducted to determine the effects of (1) operational exposure (cycling) of the circuit breaker to atmospheres laden with sand of various particle sizes, (2) static exposure of the circuit breaker to those atmospheres, (3) circuit breaker design (two manufacturers' circuit breakers designed to the same specification), and (4) sealing or protection methods. Cycles to failure were also measured.</p> <p>It was determined that sand-laden atmosphere does affect the operation of unprotected circuit breakers (cycled and noncycled). It was also determined that 140-mesh silica flour (Military Standard 810B test sand) could penetrate even completely sealed circuit breakers.</p> <p>A recommendation is made to use hermetic sealing of small, intricate components if complete protection from particle ingestion is required.</p>		

Reproduced by
NATIONAL TECHNICAL
INFORMATION SERVICE
U S Department of Commerce
Springfield VA 22151

DD FORM 1473
1 NOV 66

REPLACES DD FORM 1473, 1 JAN 64, WHICH IS
OBSOLETE FOR ARMY USE.

UNCLASSIFIED
Security Classification

Task IF162205A11906
House Task RM 70-13
USAAMRDL Technical Report 73-93
October 1973

**THE EFFECTS OF SAND PARTICLES
ON SMALL, INTRICATE MECHANICAL COMPONENTS**

Final Report

By

Donald R. Artis, Jr.

**EUSTIS DIRECTORATE
U. S. ARMY AIR MOBILITY RESEARCH AND DEVELOPMENT LABORATORY
FORT EUSTIS, VIRGINIA**

**Approved for public release;
distribution unlimited.**

SUMMARY

This report presents the results of a series of tests conducted to investigate the failure mode of binding caused by sand particles in small, intricate mechanical components. These tests were prompted by the large number of failures of components where the suspected mode of failure was binding caused by sand ingestion. The armament system circuit breaker of the AH-1G helicopter was selected as the device to be tested.

Tests were conducted to determine the effects of (1) operational exposure (cycling) of the circuit breaker to atmospheres laden with sand of various particle sizes, (2) static exposure of the circuit breaker to those atmospheres, (3) circuit breaker design (two manufacturers' circuit breakers designed to the same specification), and (4) sealing or protection methods. Cycles to failure were also measured.

It was determined that sand-laden atmosphere does affect the operation of unprotected circuit breakers (cycled and noncycled). It was also determined that 140-mesh silica flour (Military Standard 810B test sand) could penetrate even completely sealed circuit breakers.

A recommendation is made to use hermetic sealing of small, intricate components if complete protection from particle ingestion is required.

FOREWORD

The tests reported herein were conducted under DA Task 1F162205A11906, "Reliability/Environmental Technology," House Task RM 70-13. This effort is part of the reliability and maintainability program being carried out at the Eustis Directorate, U. S. Army Air Mobility Research and Development Laboratory, Fort Eustis, Virginia.

Technical assistance and advice were provided by Mr. James C. Edwards, engineering technician, who designed the test fixture and pneumatic and electrical systems; Mr. Dominic P. Iannuzzi, aeronautical engineering technician, who operated and maintained the test equipment and recorded the test data; and Mr. Roger B. Hayman, Jr., equipment specialist, who assisted and advised the project engineer throughout the tests.

TABLE OF CONTENTS

	<u>Page</u>
SUMMARY	iii
FOREWORD	v
LIST OF ILLUSTRATIONS	viii
LIST OF TABLES	ix
LIST OF SYMBOLS	x
INTRODUCTION	1
TEST METHODOLOGY AND PROCEDURE	2
OBSERVATIONS	11
FINDINGS AND CONCLUSIONS	15
RECOMMENDATIONS	17
LITERATURE CITED	18
APPENDIXES	
I. Justification for Changing Forces To Open and Close Circuit Breakers When Using Dust Boots	19
II. Analysis of the Effects of Various Sand Samples on the Cycles to Failure of Plunger-Type Circuit Breakers	27
III. Analysis of the Effect of Cycling on the Force To Open and Close Plunger-Type Circuit Breakers	57
IV. Analysis of the Effect of Sand on the Force To Open Plunger-Type Circuit Breakers	94
V. Analysis of the Effect of Sand on the Force To Close Plunger-Type Circuit Breakers	118
DISTRIBUTION	140

Preceding page blank

LIST OF ILLUSTRATIONS

<u>Figure</u>		<u>Page</u>
1	Sand and Dust Test Chamber	4
2	Temperature/Humidity Chamber for Clean Test	4
3	Circuit Breaker Test Setup.....	5
4	Circuit Breaker Test Setup (Installed)	5
5	Electrical Schematic	6
6	Pneumatic Schematic	7
7	Control Unit for Circuit Breaker Tests	7
8	Sand Test Samples	8
9	Standard Circuit Breaker	9
10	Completely Sealed Circuit Breaker	9
11	Completely Sealed Circuit Breakers Installed	9
12	Broken Plungers During Testing	12
13	Broken Plunger (Cap Separation)	12
14	Broken Plunger (Fracture)	13
15	Fractured Yoke Mechanism (Lower)	13
16	Fractured Yoke Mechanism (Upper)	14
17	Binding Roller Mechanism	14
18	Mean Cycles to Failure Versus Sand Samples for Unprotected Circuit Breakers	28
19	Mean Cycles to Failure Versus Sand Samples	56
20	Mean Force To Open Versus Sand Samples	112
21	Mean Force To Close Versus Sand Samples	132

LIST OF TABLES

<u>Table</u>		<u>Page</u>
I	Electrical Components	6
II	Sand Test Sample Distributions	8
III	Circuit Breaker Cycling and Exposure Tests	10

LIST OF SYMBOLS

ANOVA	analysis of variance
d	maximum absolute difference
d.f.	degrees of freedom
E_i	expected number of observations in the i^{th} interval
F	distribution associated with the ratio of two independent chi-squared distributions
$F_{K-1, nK-K; 1-\alpha}$	extracted from Reference 7 (Table D, pages 270-275)
$\hat{F}(X)$	portions of the sample observations that are less than or equal to X
G_{Z_L}	$\int_{Z_L}^{\infty} \frac{1}{\sqrt{2\pi}} e^{-t^2/2} dt$
G_{Z_U}	$\int_{Z_U}^{\infty} \frac{1}{\sqrt{2\pi}} e^{-t^2/2} dt$
K	number of parameters (catalysts) being examined
L_i	lower limit of the i^{th} interval
LSR	least significant range
MS	mean squared
N	K times n
n	total sample size within each catalyst
O_i	number of sample observations in the i^{th} interval
P	means of sets for each parameter
r_{ij}	test statistic for the Dixon criterion of the treatment of outliers
r_p	significant studentized ranges for a 5-percent level multiple range test (obtained from Reference 8, Table E, page 277)
SiO_2	silicon dioxide
SS	sums of squares
SSCAT	sums of squares (catalysts)

SSERR	sums of squares (error)
SST	sums of squares (total)
T	total of a series or group of numbers
U_i	upper limit of the i^{th} interval
X	data points
\bar{X}	mean
X_L	lower value of the i^{th} interval in the chi-squared goodness-of-fit test
X_U	upper value of the i^{th} interval in the chi-squared goodness-of-fit test
\bar{y}_n	average value of a series of numbers = T/n
Z_L	$\frac{X_L - \mu}{\sigma}$
Z_U	$\frac{X_U - \mu}{\sigma}$
α	level of significance
ϵ_{ij}	error term
μ	population mean
σ	population variance
χ^2	chi-squared

INTRODUCTION

The mechanisms of failure of mechanical components associated with a sand-particle-laden atmosphere include erosion, abrasion, clogging and binding. This report addresses a study of the mechanism of binding as a failure mode. The remaining mechanisms have been addressed by other studies, such as USAAMRDL Technical Report 70-70, "Study of the Mechanisms of Sand and Dust Erosion".¹ The primary areas of interest to be investigated concerning particle binding of mechanical components were particle size distribution effects and the effectiveness of sealing methods against particles, excluding hermetic sealing, which uses an inert gas for displacement of atmospheric air in the component. Candidate components for this study were investigated, and the armament circuit breakers used on the AH-1G helicopter were selected for testing. These 15-ampere DC armament circuit breakers (described in Reference 2) have had to be replaced at a fairly high rate and represent a nuisance and potentially dangerous condition (i.e., binding circuit breakers may not function as circuit breakers when required).

The standing operating procedure (SOP) in Vietnam was to pull the armament circuit breakers into an open circuit position whenever an aircraft was operating over a friendly landing zone or leaving or returning to a base camp. This SOP (Reference 3) resulted in the armament circuit breakers' being operated as switches instead of solely as circuit breakers. The failed and/or replaced circuit breakers in the field contained sand in minute amounts, a factor that may not be critical in itself but which, combined with the misused circuit breakers, may cause frequent failures.

The objectives of this investigation were to determine the effects of different sand particle size distributions on the cycles to failure of the armament circuit breakers and to assess the influence of cycling the plunger arm on the useful life of the circuit breakers.

TEST METHODOLOGY AND PROCEDURE

It was noted during the planning stages of this test program that the military specifications governing the qualification of small mechanical components did not require the circuit breakers to be actuated in a sand-particle-laden atmosphere during the contractor's qualification testing prior to acceptance by the Army. Since the circuit breakers are exposed to sand particles when operating in the field, the qualification tests performed by the contractor were not representative of service or actual conditions. Therefore, the test plan for this investigation called for testing the circuit breakers under conditions that were as representative of actual field conditions as possible. To duplicate field conditions, it is necessary to mechanically actuate the circuit breaker plunger while the circuit breaker is exposed to blowing sand particles and a controlled temperature.

The test methods used in this investigation were dictated by design-of-experiment techniques. The small sand and dust chamber available at the Eustis Directorate (shown in Figure 1) was used for the tests. In addition, the temperature/humidity chamber of the Eustis Directorate was used for the clean (no blowing sand particles) environment as shown in Figure 2. The test fixture itself is shown in an artist's concept in Figure 3 and by photograph in Figure 4.

The number of circuit breakers exposed per test was restricted to five due to space limitations of the sand chamber. Since analysis-of-variance techniques were to be used to assess the impact of cycling and sand particle size distribution on circuit breaker effectiveness at the 5-percent level of significance, a number of replications of each test point were required. Five replications were considered to be sufficient for analysis purposes.

Test conditions for each investigation were kept uniform by rigid monitoring and control. The sand cloud density was held constant for each sand test, with only the particle size distribution changing. A temperature of $104^{\circ}\text{F} \pm 2^{\circ}\text{F}$ and a relative humidity of 30 percent or less were maintained throughout these tests. The temperature was considered to be representative of the interior of the AH-1G in a tropical environment, and the low humidity was required to preclude adherence of the particles due to moisture during these tests.

The electrical and pneumatic schematics for the test fixtures are shown in Figures 5 and 6 respectively. Table I is a list corresponding to Figure 5, which describes the items used in the electrical system. Figure 7 shows the control unit and counters for each circuit breaker. It should be noted that each test had five circuit breakers at a time that were cycled and a control group of five circuit breakers that were exposed to the blowing sand only but not cycled. This was done to allow a comparative analysis to be made, following testing, of the effects of actuation on the force required to open and close the circuit breakers. Blowing sand for the purpose of these tests was sand moving at 100 to 500 feet per minute (1.1 to 5.7 miles per hour). In the case of the clean test, a zero air velocity was used. The samples used for testing were SiO_2 (quartz) and 140-mesh silica flour sand particles, with size distributions as shown in Table II and Figure 8. During testing, the circuit breakers were either unprotected, dust-boot protected, or completely sealed (dust boot plus pitch).

The circuit breakers were operated by actuating their plunger arms vertically with a force of 8 pounds tension and 12 pounds compression if no dust boots were used and 7 pounds and

14 pounds, respectively, if a dust boot was used (Appendix I contains the justification for the variation in the tensile and compressive forces with and without boots).

The circuit breakers were assumed to have failed when either the compressive or the tensile force required to actuate the circuit breaker exceeded the present test fixture actuation forces (7 or 8 pounds, 12 or 14 pounds), the plunger itself broke or fractured, or the circuit breakers actuated properly but continued to retain an open or closed circuit.

It was assumed that the failures would be normally distributed. This assumption could not be rejected, as shown by the Kolmogorov-Smirnov goodness-of-fit tests outlined in Reference 4 and shown in Appendixes I, II, IV, and V of this report.

The tests shown in Table III were conducted to determine the influence of sand particle size distribution and cycling on circuit breaker operation. No examination was made of dust-boot-protected circuit breakers in a clean environment because it was assumed that there would be no difference in a clean environment between an unprotected circuit breaker and one with a dust boot installed. However, the completely sealed circuit breakers were examined in a clean environment because they were a special purchase from one of the manufacturers (designated manufacturer number 1) of these circuit breakers, and it was surmised that there might be differences due to quality control induced by the special purchase.

Following the chamber tests, a linear spring scale, calibrated in pounds, was used to measure the opening and closing forces required for each circuit breaker. In addition, an electrical test was performed on those circuit breakers which could be actuated regardless of the forces required to operate the plungers. The electrical test was performed under the following conditions: 60 amperes at 28 volts DC for no more than 7 seconds. The circuit breaker had to actuate (open the circuit) within 7 seconds or fail the test.

Figure 9 is a photograph of the standard circuit breaker's internal components, generally referred to as the unprotected circuit breaker; one-half of its covering has been removed to show its interior. Figure 10 is a photograph of the completely sealed circuit breaker with the dust boot removed and lying to one side. This same type of dust boot was added to the circuit breaker shown in Figure 9 to obtain a standard circuit breaker with a dust boot for use in these tests. Figure 11 shows the completely sealed circuit breakers installed and ready for testing. Note the dust boots and sealer at the potential sand entrance areas.



Figure 1. Sand and Dust Test Chamber.

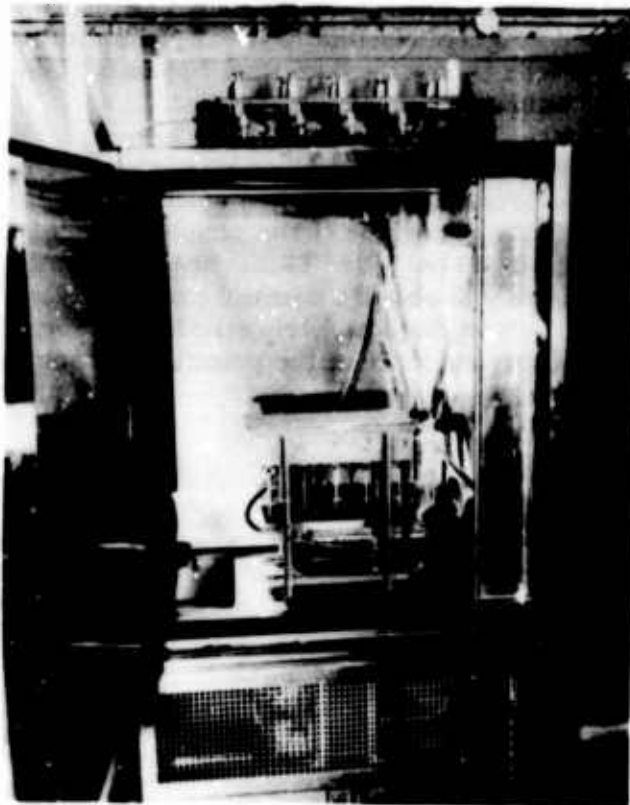

Figure 2. Temperature/Humidity Chamber for Clean Test.

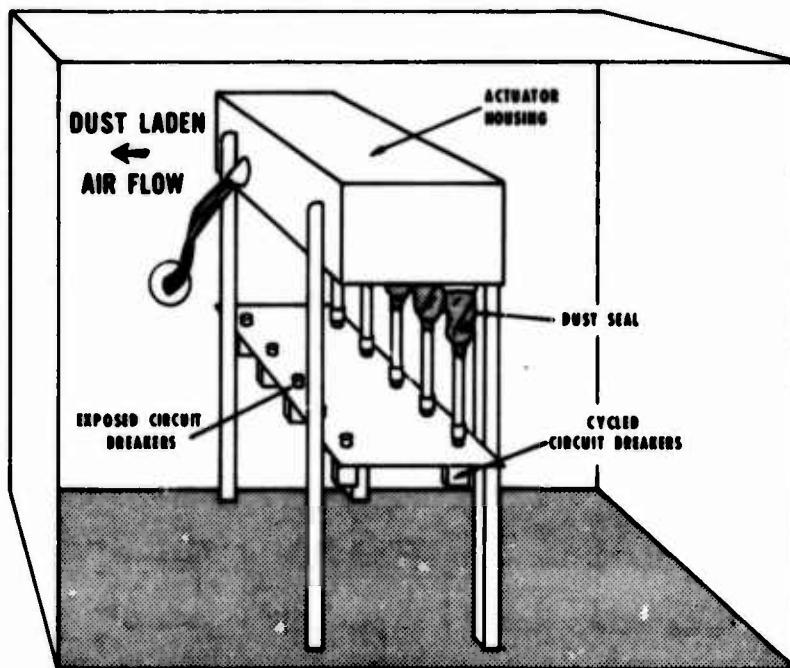

Figure 3. Circuit Breaker Test Setup.

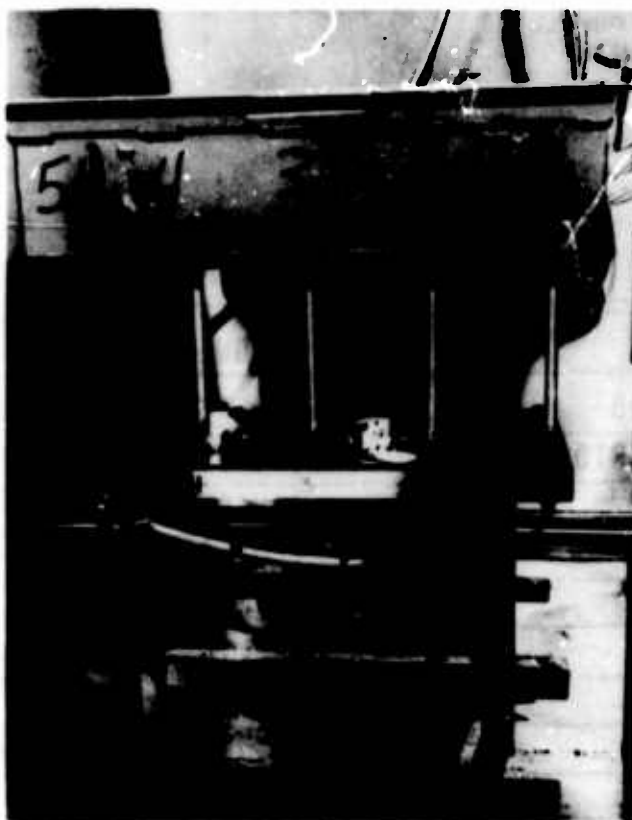

Figure 4. Circuit Breaker Test Setup (Installed).

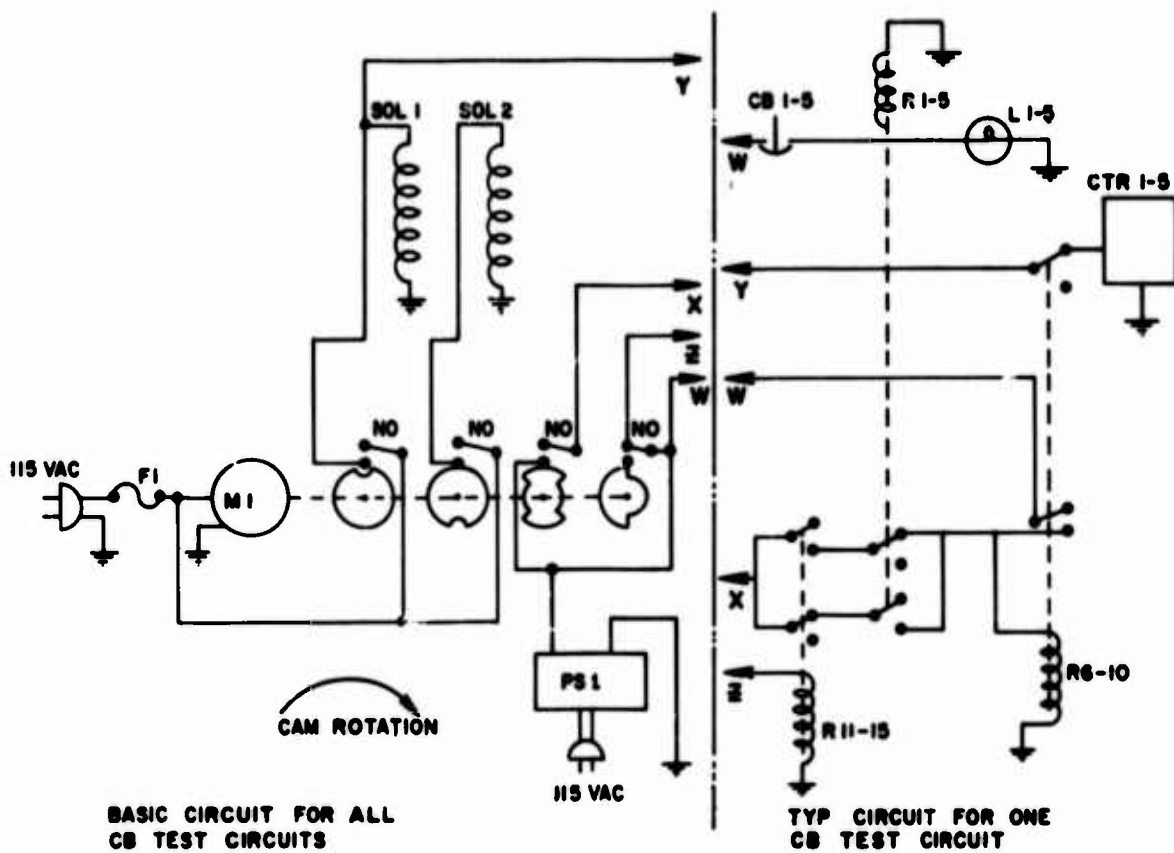

Figure 5. Electrical Schematic.

TABLE I. ELECTRICAL COMPONENTS	
REF DES	NOMENCLATURE
CB1 THRU CB5	CIRCUIT BREAKER, TEST 15 AMP
CRT1 THRU CRT5	COUNTER, 4 DIGIT RESETABLE 115VAC
F1	FUSE, 115VAC 1 AMP
L1 THRU L5	LAMP, PILOT 28VDC
M1	MOTOR
PS1	POWER SUPPLY, 28VDC
R1 THRU R5	RELAY, 28VDC
R6 THRU R10	RELAY, 28VDC
R11 THRU R15	RELAY, 28VDC
SOL1 THRU SOL2	SOLENOID

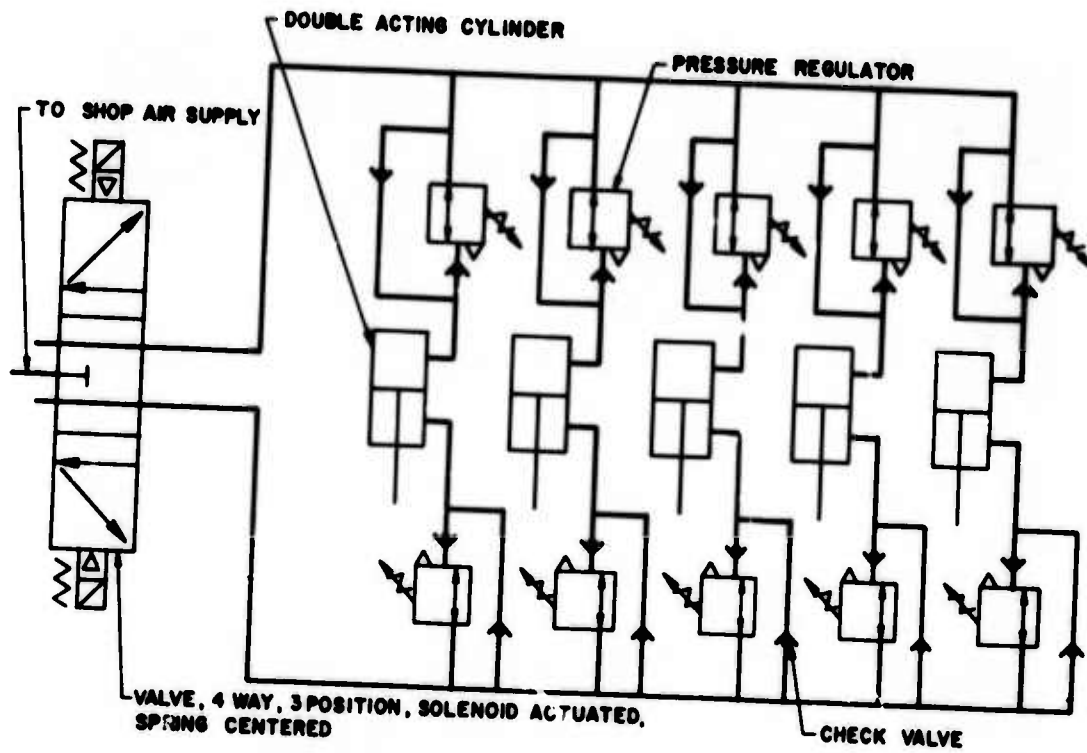

Figure 6. Pneumatic Schematic.

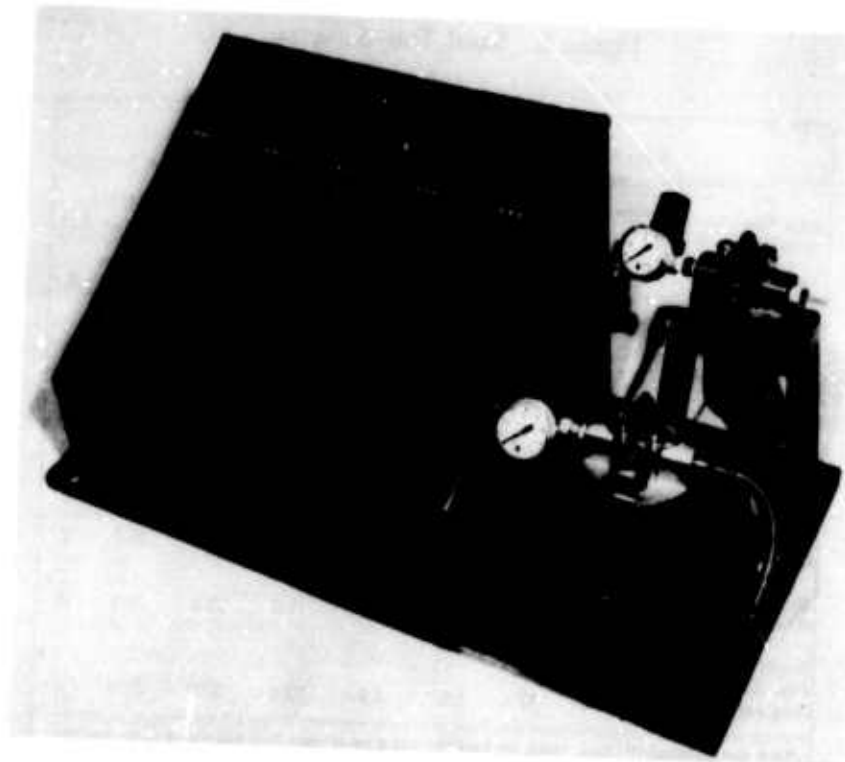

Figure 7. Control Unit for Circuit Breaker Tests.

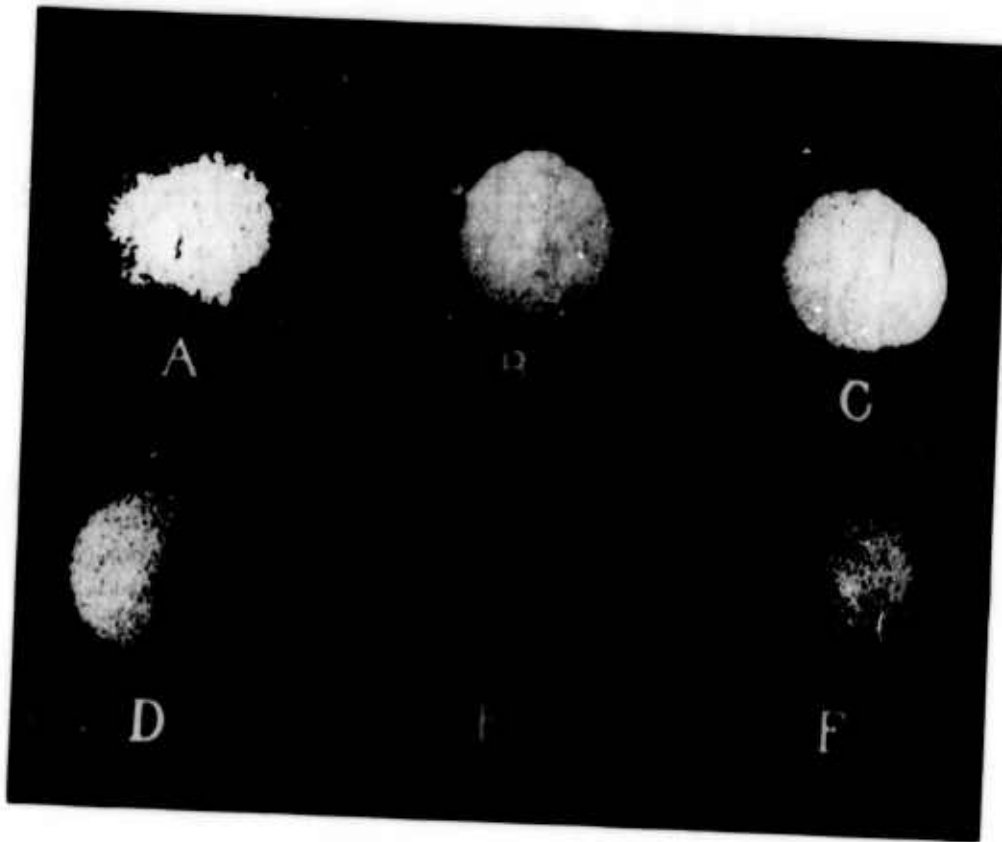

Figure 8. Sand Test Samples.

TABLE II. SAND TEST SAMPLE DISTRIBUTIONS									
Sand Test Samples	Percent by Weight of Total Sample* Within a Size Range (microns)**								
	0-74	74-88	88-105	105-128	125-177	177-250	250-350	350-500	500
140-Mesh Silica Flour	90.0	8.0	2.0 (none > 150)		0	0	0	X	
Desert Area (Kingman, Arizona)	65.5	6.8	4.0	4.6	7.0	3.0	2.0	3.5	X
Inland Area, Non-Desert (Saigon, RVN)	24.6	4.0	4.4	5.0	13.0	11.0	11.0	13.0	X
Road Dust (Fort Benning, Georgia)	4.2	1.0	1.2	1.6	11.0	18.0	28.0	26.0	X
Beach Area (Da Nang, RVN)	1.6	1.0	1.0	2.4	10.0	19.0	25.0	24.0	X
Beach Sand (Va. Beach, Virginia)	0	0	0	1.0	2.5	22.5	37.0	20.0	X

*For the purposes of these tests, no particle was greater than 500 microns due to recommendations cited in Reference 5.

**Micron sizes were obtained from Reference 6.

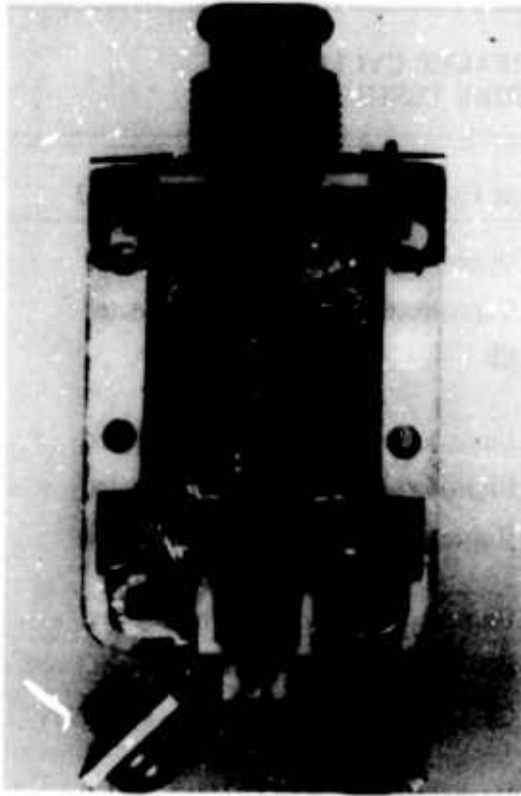

Figure 9. Standard Circuit Breaker.

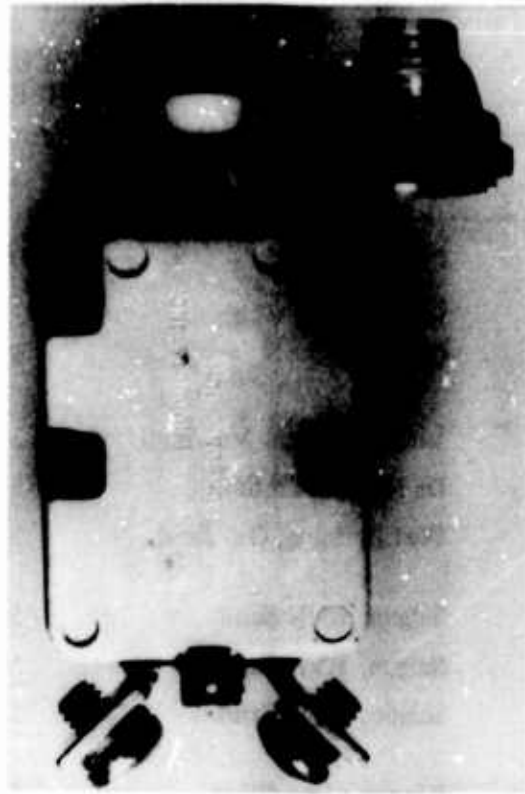

Figure 10. Completely Sealed Circuit Breaker.

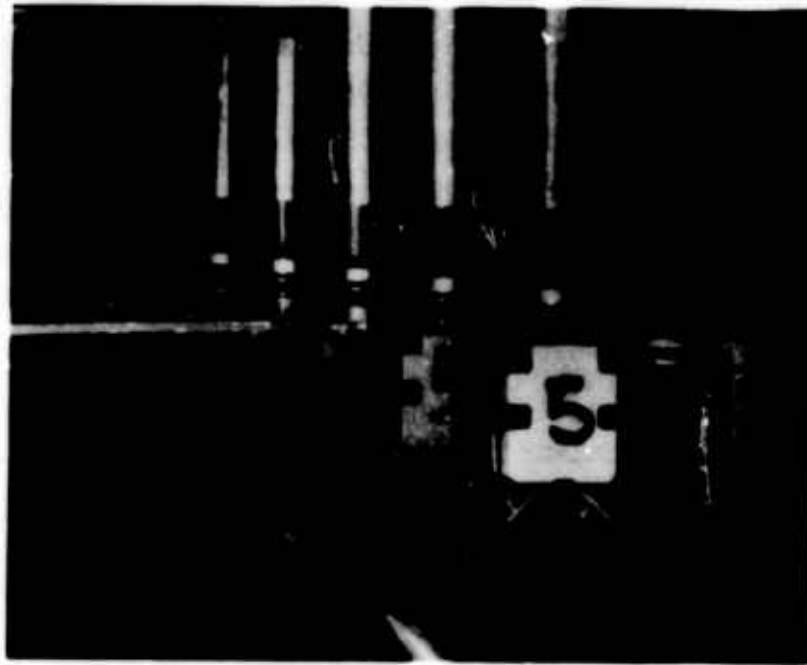

Figure 11. Completely Sealed Circuit Breakers Installed.

**TABLE III. CIRCUIT BREAKER CYCLING
AND EXPOSURE TESTS**

Test	Number Cycled	Number Noncycled
Clean	<u>10</u> (1)* Unprotected	<u>5</u> (1) Unprotected
Clean	<u>5</u> (2) Unprotected	<u>5</u> (2) Unprotected
Clean	<u>5</u> (1) CS	<u>5</u> (1) CS
Virginia Beach, Va. Sand	<u>5</u> (1) Unprotected	<u>5</u> (1) Unprotected
Da Nang, RVN Sand	<u>5</u> (1) Unprotected	<u>5</u> (1) Unprotected
Fort Benning, Ga. Sand	<u>5</u> (1) Unprotected	<u>5</u> (1) Unprotected
Saigon, RVN Sand	<u>5</u> (1) Unprotected	<u>5</u> (1) Unprotected
Saigon, RVN Sand	<u>5</u> (1) DB	<u>5</u> (1) DB
Saigon, RVN Sand	<u>5</u> (1) CS	<u>5</u> (1) CS
Kingman, Az. Sand	<u>5</u> (1) Unprotected	<u>5</u> (1) Unprotected
Kingman, Az. Sand	<u>5</u> (1) DB	<u>5</u> (1) DB
Kingman, Az. Sand	<u>5</u> (1) CS	<u>5</u> (1) CS
140-Mesh Silica Flour Sand	<u>5</u> (1) Unprotected	<u>5</u> (1) Unprotected
140-Mesh Silica Flour Sand	<u>5</u> (1) DB	<u>5</u> (1) DB
140-Mesh Silica Flour Sand	<u>5</u> (1) CS	<u>5</u> (1) CS

*Number underlined is the number cycled or exposed. Number in parenthesis indicates manufacturer number 1 or 2. Manufacturer number 2 circuit breakers were examined in a clean environment only due to time and cost considerations.

Note: Unprotected means not sealed against sand entry. DB means only a dust boot was added for protection. CS means a dust boot plus pitch was added to seal all possible entrances to the circuit breaker interior.

OBSERVATIONS

Of the 80 circuit breakers cycled during these tests, 79 failed during cycling. One cycled for so long that the test was terminated (11,099 achieved; 5,000 required). The following statements pertain to the remaining 79 circuit breakers:

- In a dust-laden atmosphere, 83 percent of the unprotected circuit breakers could not be pulled open, compared to 80 percent of the circuit breakers protected only by dust boots and 53 percent of the completely sealed circuit breakers.
- Sixteen percent of the completely sealed circuit breakers had broken plungers, compared to 5 percent of the unprotected and 7 percent of the dust-boot-protected circuit breakers.
- Thirty-one percent of the completely sealed circuit breakers opened by themselves, compared to 10 percent of the unprotected and 13 percent of the dust-boot-protected circuit breakers.
- Eighty percent of the circuit breakers of manufacturer number 2 had broken plungers following testing. Figure 12 shows a typical set of plunger breakage type failures. Figures 13 and 14 are close-ups of some typical plunger breaks.
- Seventy-one percent of all failed circuit breakers could not be pulled open.
- Thirteen percent of all failed circuit breakers had broken plungers.
- Fifteen percent of all failed circuit breakers opened by themselves.
- One percent of all failed circuit breakers failed such that electrical current continued to flow through the circuit breaker independent of the plunger's position.
- Of the 66 cycled circuit breakers, only 4 failed to meet the time limit within which the circuit breaker must open if mechanically and electrically closed and exposed to 400 percent of rated current. Twelve circuit breakers would not seat using an unlimited force; therefore, no electrical test could be performed.
- Of the 80 noncycled circuit breakers, only one failed to pass the electrical test. All the circuit breakers would seat using an unlimited force.

A suspected cause of the nonseating of some of the cycled circuit breakers was fatigue failure of an internal collar which thereby rendered the plunger ineffective as a means of actuating the cam arrangement to seat the circuit breaker. Figures 15 and 16 show typical failures of the collar or yoke mechanism. Figure 17 shows another type of failure experienced during these tests: the roller mechanism binding without moving into position as required.

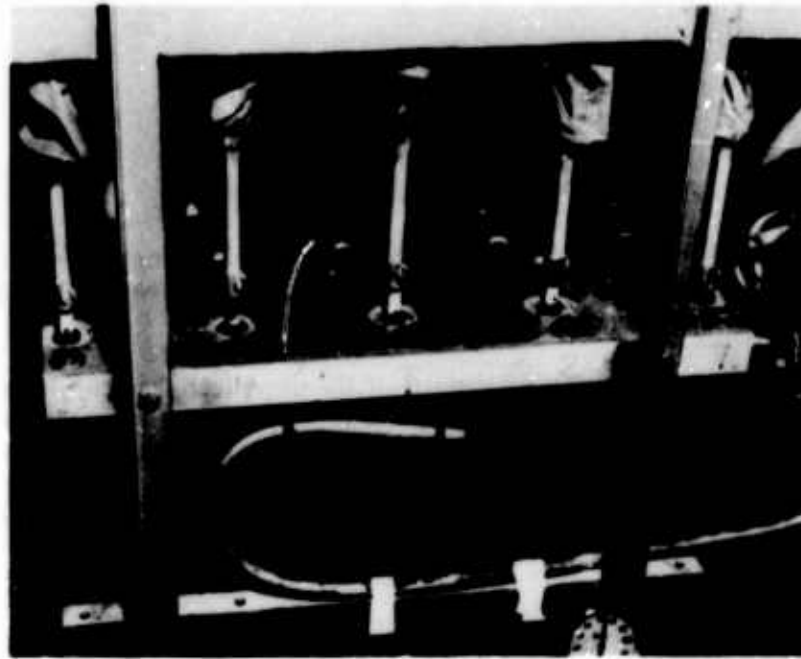

Figure 12. Broken Plungers During Testing.



Figure 13. Broken Plunger (Cap Separation).



Figure 14. Broken Plunger (Fracture).

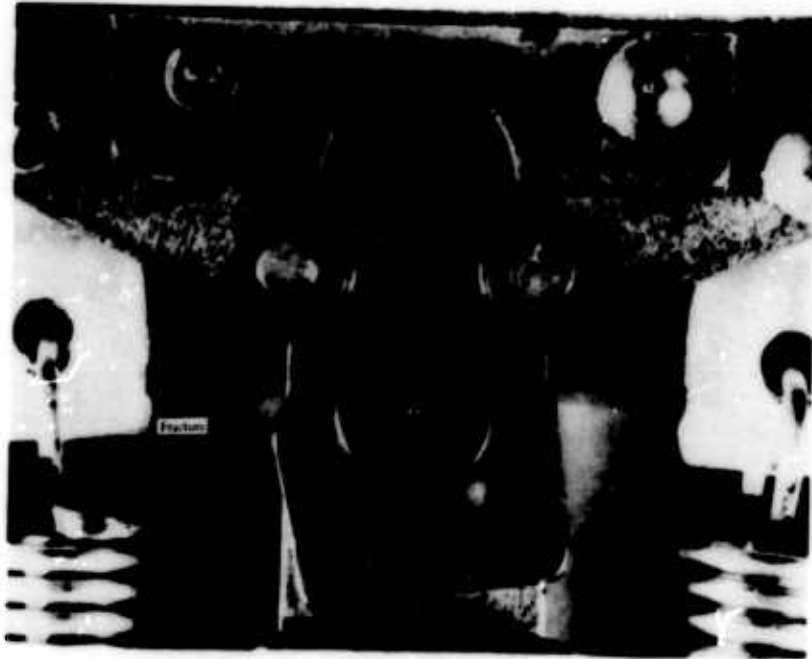

Figure 15. Fractured Yoke Mechanism (Lower).

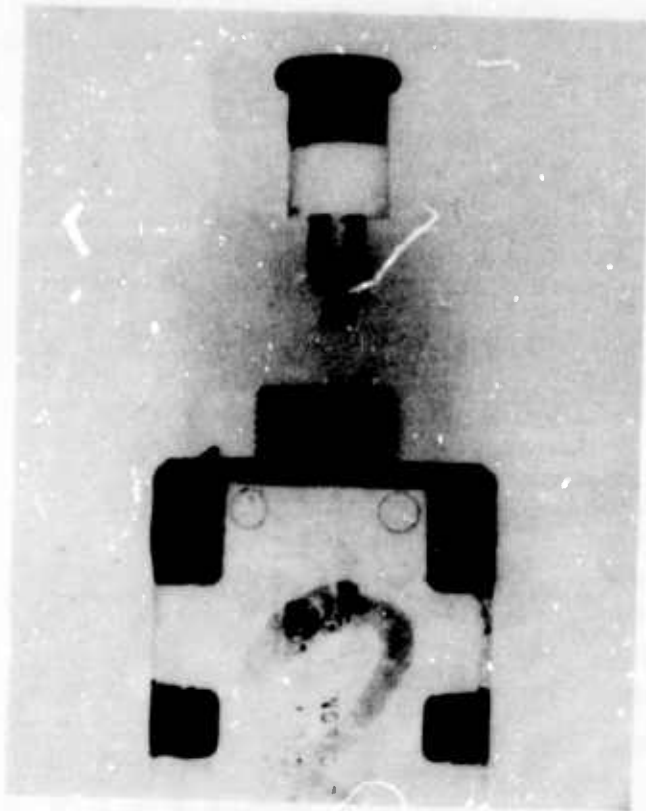

Figure 16. Fractured Yoke Mechanism (Upper).

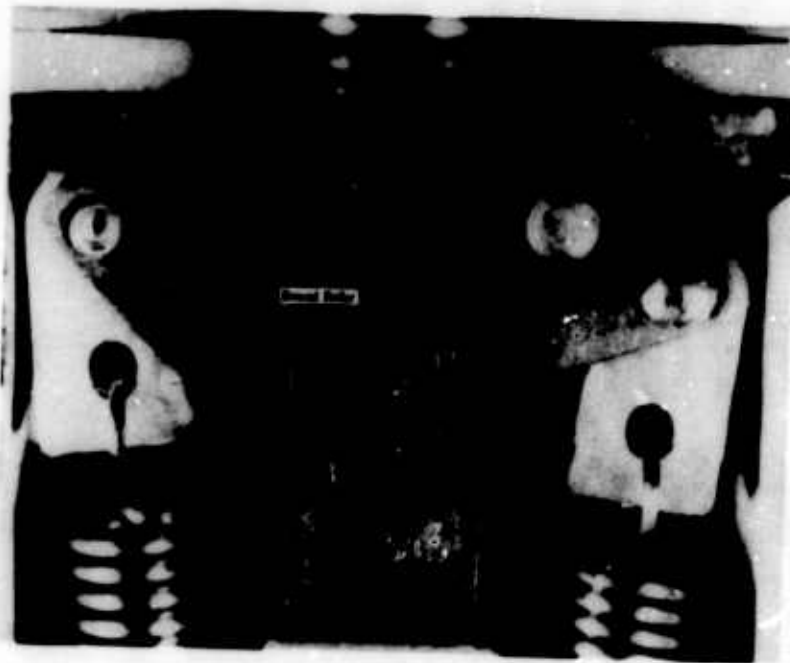

Figure 17. Binding Roller Mechanism.

FINDINGS AND CONCLUSIONS

Appendixes I through V contain analyses of variances at the 5-percent level of significance of the various tests performed during this investigation. The following conclusions have been drawn from these analyses or other data as noted:

1. Design differences can cause variances in performance and reliability of circuit breakers as shown by the differences found between the cycles to failure in a clean environment of the circuit breakers of manufacturers 1 and 2. The completely sealed circuit breakers were a special purchase, but all other circuit breakers were standard supply system purchases. The differences in cycles to failure between the completely sealed and standard circuit breakers in a clean environment must be attributed to quality control, since the only difference that was supposed to exist between the completely sealed and standard circuit breakers was the addition of a sealer and a dust boot (see Appendixes I and II).
2. The presence of a sand-laden atmosphere (regardless of the particle size) does affect the operation of unprotected cycled circuit breakers by decreasing the mean cycles to failure when compared to a clean environment. However, as protection methods become more sophisticated, only those distributions with a high concentration of fine particles (greater than 25 percent finer by weight of sand particles less than 74 microns) will cause significantly shorter mean cycles to failure of these circuit breakers (see Appendix II).
3. Mechanically cycling the circuit breakers increases the force required to open unprotected circuit breakers when operating in either a clean or a sand-laden atmosphere (see Appendix III).
4. There is no significant difference between the effects of the sand samples on the force required to open noncycled unprotected circuit breakers. Exposure to any sand-laden airflows causes a detrimental effect on the force required to open unprotected noncycled circuit breakers compared to those exposed to a clean environment (see Appendix IV).
5. For completely sealed circuit breakers, there is no significant difference in mean cycles to failure when exposed to and operated in the desert or Saigon type sand-laden atmospheres, but there is a significant difference when exposed to a 140-mesh silica flour sand-laden atmosphere. Therefore, the 140-mesh silica flour sand could penetrate even a completely sealed circuit breaker (see Appendix II).
6. There is no significant difference between the effect of the various sand samples on the force required to close this type of circuit breaker, whether cycled, noncycled, protected, or unprotected. Due to the design of the circuit breaker, actuation of the plunger to complete or close the circuit causes the internal mechanism to operate in a manner that precludes binding; i.e., spaces between potential binding surfaces become larger. However, this condition may not be true for other small, intricate mechanical components (see Appendixes III and V).

7. As the amount of fine particles (less than 74 microns) increases, a greater amount of sealing is required to minimize the impact on the force required to open circuit breakers. Therefore, any similar small, intricate mechanical component would likewise require greater sealing as the amount of fine particles (less than 74 microns) increases in a sand-laden atmosphere, to preclude failures due to binding caused by sand particles (see Appendixes III and IV).
8. The specifications governing qualification of these components in a sand-laden atmosphere were not adequate (Military Specification 5809 and Military Standards 810 and 202). These specifications do not require the component to be operated during the sand tests. Currently, the procuring agency has to determine whether or not the component is to be operated during sand tests. By requiring operation during sand testing and imposing those conditions on the contractor, more realistic qualification testing would occur, compared to the currently specified nonoperating sand test.

RECOMMENDATIONS

Based on the results and conclusions of this investigation, it is recommended that:

1. When it is deemed necessary to protect a U. S. Army aircraft component against particle ingestion to prevent binding, hermetic sealing of that component be used, with attention given to maintenance and replacement considerations. Hermetic sealing would be defined in this case as completely and permanently sealing the component with an inert gas trapped inside.
2. 140-mesh silica flour or equivalent be used for conducting sand tests of small, intricate mechanical components, if particle binding is a suspected mode of failure.
3. Military Standard 202A, "Test Methods for Electronic and Electrical Component Parts"; Military Standard 810B, "Environmental Test Methods"; and Military Specification 5809C, "Circuit Breakers, Trip-Free, Aircraft, General Specification for", be changed to reflect a requirement that components being subjected to sand tests be operated during the tests. The component operation should be in a manner that duplicates the type of operation normally expected in service.
4. Circuit breakers be used as switches only if they are specifically designed to function as such.

LITERATURE CITED

1. Finnie, I., **STUDY OF THE MECHANISMS OF SAND AND DUST EROSION**, Solar Division, International Harvester Co.; USAAMRDL Technical Report 70-70, Eustis Directorate, U. S. Army Air Mobility Research and Development Laboratory, Fort Eustis, Virginia, December 1970, AD 880679.
2. Military Standard 25244 (ASG), "Circuit Breaker, Trip-Free, Push-Pull, 1 thru 35 Amperes, Type I".
3. ACTIV Project No. ACA-38F, Final Report, **FIELD EXPEDIENT SYSTEMS IN USE BY ARMY AVIATION IN RVN**, Department of the Army, Army Concept Team in Vietnam, page II-73 and II-74.
4. U. S. Army Materiel Command Pamphlet 702-3, **QUALITY ASSURANCE, RELIABILITY HANDBOOK**, October 1968.
5. Rodgers, Sheridan J., **EVALUATION OF THE DUST CLOUD GENERATED BY HELICOPTER ROTOR DOWNWASH**, MSA Research Corp.; USAAVLABS Technical Report 67-81, U. S. Army Aviation Materiel Laboratories, Fort Eustis, Virginia, March 1968, AD 669676.
6. **SAND AND DUST REPORT - LYCOMING GAS TURBINE ENGINES**, Report Number 125.1.4, Lycoming, Division of AVCO, June 1965.
7. U. S. Army Materiel Command Pamphlet 706-113, **ENGINEERING HANDBOOK**, Experimental Statistics, Section 4-Special Topics, December 1969.
8. Hicks, Charles R., **FUNDAMENTAL CONCEPTS IN THE DESIGN OF EXPERIMENTS**, Holt, Rinehart and Winston, Inc., New York, 1964.

APPENDIX I
JUSTIFICATION FOR CHANGING FORCES TO
OPEN AND CLOSE CIRCUIT BREAKERS
WHEN USING DUST BOOTS

Five standard circuit breakers were examined in the following manner to determine whether or not the operating forces specified by military standards should be changed when a dust boot is added to the circuit breaker:

No Dust Boot		Dust Boot Added	
Force To Close (lb)	Force To Open (lb)	Force To Close (lb)	Force To Open (lb)
6.00	5.50	8.00	3.50
6.50	5.25	9.25	6.25
5.75	4.00	9.00	3.00
7.00	5.75	12.50	3.75
6.75	3.25	8.25	3.25
<u>32.00</u>	<u>23.75</u>	<u>47.00</u>	<u>19.75</u>
$\div 5 = 6.40$	$\div 5 = 4.75$	$\div 5 = 9.40$	$\div 5 = 3.95$

The tabulation above indicates that the force required to open the circuit breaker with a dust boot installed is approximately 1 pound less than the circuit breaker without a dust boot. In addition, the force required to close the circuit breaker with a dust boot installed is approximately 3 pounds more than the circuit breaker without a dust boot. However, it should be noted that two of the data points (12.50 pounds and 6.25 pounds under the "dust boot added" column) are suspect and bear examination due to their wide variation from the other data points. They are termed outliers, and their treatment is discussed in Section 17-3.2.1 of Reference 7. Using the Dixon criteria discussed therein and assuming that $\alpha = 0.05$, both data points may be discarded, and the forces required due to the dust boot addition may be calculated based on the remaining data points.

No Dust Boot		Dust Boot Added	
Force To Close (lb)	Force To Open (lb)	Force To Close (lb)	Force To Open (lb)
6.00	5.50	8.00	3.50
6.50	5.25	9.25	3.00
5.75	4.00	9.00	3.75
7.00	5.75	8.25	3.25
6.75	3.25	<u>34.50</u>	<u>13.50</u>
<u>32.00</u>	<u>23.75</u>	$\div 4 = 8.63$	$\div 4 = 3.38$
$\div 5 = 6.40$	$\div 5 = 4.75$		

The tabulation above indicates that a dust-boot-protected circuit breaker will require approximately 2 pounds more force to close than an unprotected circuit breaker. Hence, the

maximum allowable force of 12 pounds to close an unprotected circuit breaker should be changed to 14 pounds when a dust boot is used in these tests. In addition, the force required to open a dust-boot-protected circuit breaker should be decreased to 7 pounds instead of the 8 pounds allowed for an unprotected circuit breaker.

Comparison of Cycles to Failure of Two Similar Plunger-Type Circuit Breakers Operating in a Clean Environment To Determine Design Influence

(Military Standard 25244 - Circuit Breakers, Trip-Free, Push-Pull, 15 Amp, Type 1)

Manufacturer No. 1		Manufacturer No. 2	
Specimen No.	Cycles to Failure	Specimen No.	Cycles to Failure
1	2100	41	1041
2	2930	42	2501
3	2945	43	514
4	2917	44	709
5	2844	45	2014
6	3478		
7	3313		
8	2200		
9	1651		
10	945		

$$T_2 = 6779$$

$$T_1 = 25,323$$

$$T.. = 32,102$$

Observations: N = 15
K = 2

Mean Cycles to Failure: Manufacturer No. 1 → 25,323/(10) = 2532.3
Manufacturer No. 2 → 6779/(5) = 1355.8

Source	d.f.	SS	MS	F ratio (Cat ÷ Err)
Catalyst	1	4,613,841.1	4,613,841.1	F cal = 6.94
Error	13	8,641,782.9	664,752.5	
Total	14	13,255,624.0		

$$SST = (2100)^2 + (2930)^2 + \dots + (2014)^2 - T..^2/15$$

$$SST = 81,958,184.0 - 68,702,560$$

$$SST = 13,255,624$$

$$SSCAT = (25,323)^2/(10) + (6779)^2/(5) - T..^2/15$$

$$SSCAT = 64,125,432.9 + 9,190,968.2 - 68,702,560$$

SSCAT = 4,613,841.1
SSERR = SST - SSCAT
SSERR = 8,641,782.9
$F_{1, 13; .95} = 4.67 < F_{cal} = 6.94$

Therefore, it is concluded that there is a significant difference between the mean cycles to failure of these two circuit breakers. Since the circuit breakers were qualified to the same specification, it is concluded that there is a design difference between the breakers which significantly contributes to the difference in their mean cycles to failure. It should be noted that the previous discussion does not imply that the tests performed under this program duplicated those used to qualify the components. Rather, these series of tests were used as a basis for judgment purposes; i.e., one test was compared to another test only.

In order to apply the analysis of variance techniques, certain assumptions were made:

1. The process was repeatable. The process was controlled as closely as possible. This report contains a description of the test conditions, apparatus, and specimens.
2. The population being sampled was normally distributed, as shown by the Kolmogorov-Smirnov goodness-of-fit tests found at the end of this appendix and in Appendixes II, IV, and V. The other combinations which could be construed to form separate samples (completely sealed and dust boot added only specimens) were variations of those examined by the goodness-of-fit tests noted above and were assumed to be normally distributed also.
3. The error terms, e_{ij} , were considered to be normally and independently distributed random effects whose mean value was zero and variance was the same for all levels being examined.

Kolmogorov-Smirnov Goodness-of-Fit Tests for Standard Circuit Breakers in a Clean Environment

Four Kolmogorov-Smirnov goodness-of-fit tests for the standard circuit breakers exposed, during cycling, to a clean environment are presented on the following pages. In each case, the assumption of a normal distribution cannot be rejected.

1. Distribution of Cycles to Failure of the Circuit Breakers of Manufacturer No. 1

Assume: Normal Distribution; $\alpha = 0.05$

<u>Specimen Number</u>	<u>Cycles to Failure</u>
1	2100
2	2930
3	2945
4	2917
5	2844
6	3478
7	3313

<u>Specimen Number</u>	<u>Cycles to Failure</u>
8	2200
9	1651
10	945
Total	25,323

$$\bar{X} = 2532.3$$

$$S^2 = \frac{\sum (X - \bar{X})^2}{n - 1} = \frac{\sum (X - 2532.3)^2}{9} = \frac{5,670,996.1}{9}$$

$$S^2 = 630,110.67$$

$$S = 793.80$$

X	$\frac{X - \bar{X}}{S}$	F(X)	$\hat{F}(X)$	$ F(X) - \hat{F}(X) $
945	-2.000	0.023	0.100	0.077
1651	-1.110	0.132	0.200	0.066
2100	-0.545	0.293	0.300	0.007
2200	-0.419	0.338	0.400	0.062
2844	0.393	0.653	0.500	0.153 Max.
2917	0.485	0.687	0.600	0.087
2930	0.501	0.692	0.700	0.008
2945	0.520	0.699	0.800	0.101
3313	0.983	0.838	0.900	0.062
3478	1.191	0.883	1.000	0.117

$$F(X) = 1 - P\left(Z > \frac{X - \bar{X}}{S}\right)$$

d = maximum absolute difference = 0.153

$d_{0.05} = 0.410$ (Table H-6, Reference 4)

$d_{\max.} = 0.153 < d_{0.05} = 0.410$

Therefore, there is no reason to reject the assumption of normality with $\mu = 2532.3$ cycles and $\sigma = 758.09$ cycles.



2. Distribution of Force To Open Following Failure

Assume: Normal Distribution; $\alpha = 0.05$

<u>Specimen Number*</u>	<u>Force To Open (lb)</u>
1	8.50
2	8.50
4	7.50
5	7.75
6	7.00
7	8.00
8	16.25
10	8.27
Total	71.75

*Specimens 3 and 9 could not be measured due to breakage of the circuit breaker plunger or some other similar problem.

$$\bar{X} = 8.97 \text{ pounds}$$

$$S^2 = \frac{\sum (X) - \bar{X})^2}{n - 1} = \frac{\sum (X - 8.97)^2}{7} = \frac{62.430}{7}$$

$$S^2 = 8.910$$

$$S = 2.986 \text{ pounds}$$

X	$\frac{X - \bar{X}}{S}$	F(X)	$\hat{F}(X)$	$ F(X) - \hat{F}(X) $
7.00	-0.660	0.255	0.125	0.130
7.50	-0.492	0.312	0.250	0.062
7.75	-0.409	0.314	0.375	0.034
8.00	-0.325	0.372	0.500	0.128
8.25	-0.241	0.405	0.625	0.220
8.50	-0.157	0.437	0.750	0.313
8.50	-0.157	0.437	0.875	0.438 Max.
16.25	2.438	0.993	1.000	0.007

$$F(X) = 1 - P\left(Z > \frac{X - \bar{X}}{S}\right)$$

d = maximum absolute difference = 0.438

$$d_{0.05} = 0.457 \text{ (Table H-6, Reference 4)}$$

$$d_{\text{max.}} = 0.438 < d_{0.05} = 0.457$$

Therefore, there is no reason to reject the assumption of normality with $\mu = 8.97$ pounds and $\sigma = 2.986$ pounds.

.....

3. Distribution of Force To Close Following a Failure

Assume: Normal Distribution; $\alpha = 0.05$

<u>Specimen Number*</u>	<u>Force To Close (lb)</u>
1	6.50
2	6.50
4	7.25
5	7.25
6	7.00
7	5.75
10	7.25
Total	47.50

*Specimens 3, 8, and 9 could not be measured for their force to close following a failure.

$$\bar{X} = 6.79$$

$$S_2 = \frac{\sum (X - \bar{X})^2}{n - 1} = \frac{\sum (X - 6.79)^2}{6} = \frac{1.928}{6}$$

$$S^2 = 0.321$$

$$S = 0.567$$

<u>X</u>	<u>$\frac{X - \bar{X}}{S}$</u>	<u>F(X)</u>	<u>$\hat{F}(X)$</u>	<u>$F(X) - \hat{F}(X)$</u>
5.75	-1.83	0.034	0.143	0.109
6.50	-0.51	0.305	0.286	0.019
6.50	-0.51	0.305	0.429	0.124
7.00	0.37	0.644	0.572	0.072
7.25	0.81	0.791	0.715	0.076
7.25	0.81	0.791	1.000	0.209 Max.

$$F(X) = 1 - P\left(Z > \frac{X - \bar{X}}{S}\right)$$

$d = \text{maximum absolute difference} = 0.209$
 $d_{0.05} = 0.486 \text{ (Table H-6, Reference 4)}$
 $d_{\text{max.}} = 0.209 < d_{0.05} = 0.486$

Therefore, there is no reason to reject the assumption of normality with $\mu = 6.79$ pounds and $\sigma = 0.567$ pound.



4. Distribution of Cycles to Failure of the Circuit Breakers of Manufacturer No. 2

Assume: Normal Distribution; $\alpha = 0.05$

<u>Specimen Number</u>	<u>Cycles to Failure</u>
41	1041
42	2501
43	514
44	709
45	2014
Total	<u>6779</u>

$$\bar{X} = \frac{6779}{5} = 1355.8$$

$$s^2 = \frac{\sum (X - \bar{X})^2}{-1} = \frac{\sum (X - 1355.8)^2}{4} = \frac{2,970,786.8}{4}$$

$$s^2 = 742,696.7$$

$$s = 861.80$$

X	$\frac{X - \bar{X}}{S}$	F(X)	$\hat{F}(X)$	$ F(X) - \hat{F}(X) $
514	-0.977	0.164	0.200	0.036
709	-0.751	0.227	0.400	0.173
1041	-0.365	0.358	0.600	0.242 Max.
2014	-0.764	0.778	0.800	0.022
2501	1.329	0.908	1.000	0.092

$$F(X) = 1 - P\left(Z > \frac{X - \bar{X}}{S}\right)$$

d = maximum absolute difference = 0.242

$d_{0.05} = 0.565$ (Table H-6, Reference 4)

$d_{\max.} = 0.242 < d_{0.05} = 0.565$

Therefore, there is no reason to reject the assumption of normality with $\mu = 1355.8$ cycles and $\sigma = 861.80$ cycles.

.....

APPENDIX II
ANALYSIS OF THE EFFECTS OF VARIOUS SAND SAMPLES
ON THE CYCLES TO FAILURE OF
PLUNGER-TYPE CIRCUIT BREAKERS

This appendix contains the one-way classification analysis of variance for the effects of various blowing sand samples on the efficient operation of plunger-type circuit breakers.

1. Effect of Blowing Sand on the Cycles to Failure of Standard Circuit Breakers

VA	Virginia Beach Sand
DA	Da Nang Sand
FB	Fort Benning Sand
S	Saigon Sand
DE	Desert Sand
SIL	140-Mesh Silica Flour Sand

VA		DA		FB	
Specimen No.	Cycles to Failure	Specimen No.	Cycles to Failure	Specimen No.	Cycles to Failure
11	991	16	1778	21	908
12	1319	17	2231	22	1831
13	640	18	1428	23	327
14	1330	19	685	24	1673
15	1016	20	1981	25	1577
$T_1 = 5296$		$T_2 = 8103$		$T_3 = 6316$	

S		DE		SIL	
Specimen No.	Cycles to Failure	Specimen No.	Cycles to Failure	Specimen No.	Cycles to Failure
26	2300	31	1087	36	1434
27	449	32	974	37	1627
28	650	33	219	38	874
29	3059	34	111	39	16
30	3121	35	1081	40	526
$T_4 = 9579$		$T_5 = 3472$		$T_6 = 4477$	

$T_{..} = 37,243$

Observations: N = 30
K = 6

Mean Cycles to Failure (Figure 18)

VA → 5296/(5) = 1059.2

DA → 8103/(5) = 1620.6

FB → 6316/(5) = 1263.2

S → 9579/(5) = 1915.8

DE → 3472/(5) = 694.4

SIL → 4477/(5) = 895.4

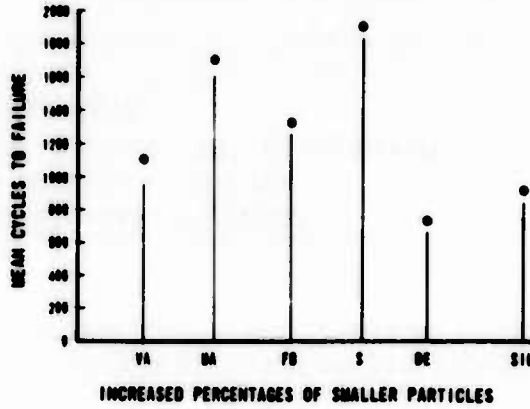

Figure 18. Mean Cycles to Failure Versus Sand Samples for Unprotected Circuit Breakers.

Source	d.f.	SS	MS	F ratio (Cat ÷ Err)
Catalyst	5	5,256,025	1,051,205.0	F cal = 1.986
Error	24	12,698,702	529,112.6	
Total	29	17,954,727		

$$\begin{aligned}
 SST &= (991)^2 + (1778)^2 + \dots + (526)^2 - (37,243)^2/30 \\
 SST &= 64,189,429 - 46,234,702 \\
 SST &= 17,954,727 \\
 SSCAT &= [(5296)^2 + (8103)^2 + \dots + (4477)^2]/(5) - 46,234,702 \\
 SSCAT &= 51,490,727 - 46,234,702 \\
 SSCAT &= 5,256,025 \\
 SSERR &= SST - SSCAT \\
 SSERR &= 12,698,702 \\
 F_{5, 24; .95} &= 2.62 > F \text{ cal} = 1.986
 \end{aligned}$$

Therefore, we can not reject the null hypothesis or conclude that there is a significant difference between the cycles to failure caused by these six sand test specimens when used during cycling tests of the standard circuit breakers.

• • • • •

2. Comparison of Cycles to Failure of Standard Circuit Breakers Exposed, During Cycling, to a Clean Environment and a Blowing Virginia Beach Sand Environment

CL		VA	
Specimen No.	Cycles to Failure	Specimen No.	Cycles to Failure
1	2100	11	991
2	2930	12	1319
3	2945	13	640
4	2917	14	1330
5	2844	15	1016
6	3478		
7	3313		
8	2200		
9	1651		
10	945		
	$T_1 = 25,323$		$T_2 = 5296$

$$T.. = 30,619$$

Observations: N = 15
K = 2

Mean Cycles to Failure

$$CL \rightarrow 25,323/(10) = 2523.3$$

$$VA \rightarrow 5296/(5) = 1059.2$$

Source	d.f.	SS	MS	F ratio (Cat ÷ Err)
Catalyst	1	7,233,412.03	7,233,412.03	
Error	13	9,094,309.9	699,562.3	F cal = 10.34
Total	14	16,327,721.9		

$$SST = (2100)^2 + (2930)^2 + \dots + (1016)^2 - T..^2/15$$

$$SST = 78,829,266 - 62,501,544.07$$

$$SST = 16,327,721.9$$

$$SSCAT = (25,323)^2/(10) + (5296)^2/(5) - 62,501,544.07$$

$$SSCAT = 69,734,956.10 - 62,501,544.07$$

SSCAT = 7,233,412.03
SSERR = SST - SSCAT
SSERR = 9,094,309.9
$F_{1, 13; .95} = 4.67$
$F_{cal} = 10.34 > F(K - 1, (nK - K); (1 - \alpha)) = 4.67$

Therefore, we can reject the null hypothesis and conclude that VA sand does have an effect on the cycles to failure of these circuit breakers under these test conditions (clean versus VA sand environment).



3. Comparison of Cycles to Failure of Standard Circuit Breakers Exposed, During Cycling, to a Clean Environment and a Blowing Da Nang Sand Environment

CL		DA	
Specimen No.	Cycles to Failure	Specimen No.	Cycles to Failure
1	2100	16	1778
2	2930	17	2231
3	2945	18	1428
4	2917	19	685
5	2844	20	1981
6	3478		<u>8103</u>
7	3313		$T_2 =$
8	2200		
9	1651		
10	945		
	$T_1 =$ <u>25,323</u>		

$T_{..} = 33,426$

Observations: N = 15
K = 2

Mean Cycles to Failure

CL → $25,323 / (10) = 2523.3$

DA → $8103 / (5) = 1620.6$

Specimen No.	Cycles to Failure
5	2844
6	3478
7	3313
8	2200
9	1651
10	945
$T_1 = 25,323$	

Specimen No.	Cycles to Failure
25	1577
$T_2 = 6316$	

$$T.. = 31,639$$

Observations: N = 15
K = 2

Mean Cycles to Failure

$$CL \rightarrow 25,323/(10) = 2523.3$$

$$FB \rightarrow 6316/(5) = 1263.2$$

Source	d.f.	SS	MS	F ratio (Cat ÷ Err)
Catalyst	1	5,368,716.03	5,368,716.03	F cal = 9.61
Error	13	7,262,436.87	558,648.99	
Total	14	12,631,152.9		

$$SST = (2100)^2 + (2930)^2 + \dots + (1577)^2 - T..^2/15$$

$$SST = 79,366,241 - 66,735,088.07$$

$$SST = 12,631,152.9$$

$$SSCAT = (25,323)^2/(10) + (6316)^2/(5) - 66,735,088.07$$

$$SSCAT = 5,368,716.03$$

$$SSERR = SST - SSCAT$$

$$SSERR = 7,262,436.87$$

$$F_{1, 13; .95} = 4.67 < F \text{ cal} = 9.61$$

Therefore, we can reject the null hypothesis and conclude that FB sand does have an effect on the cycles to failure of the circuit breakers under these test conditions (clean versus FB sand environment).



5. Comparison of Cycles to Failure of Standard Circuit Breakers Exposed, During Cycling, to a Clean Environment and a Blowing Saigon Sand Environment

CL		S	
Specimen No.	Cycles to Failure	Specimen No.	Cycles to Failure
1	2100	26	2300
2	2930	27	449
3	2945	28	650
4	2917	29	3059
5	2844	30	3121
6	3478		$T_2 = 9579$
7	3313		
8	2200		
9	1651		
10	945		
	$T_1 = 25,323$		

$T.. = 34,902$

Observations: $N = 15$
 $K = 2$

Mean Cycles to Failure

$CL \rightarrow 25,323/(10) = 2523.3$

$S \rightarrow 9579/(5) = 1915.8$

Source	d.f.	SS	MS	F ratio (Cat ÷ Err)
Catalyst	1	1,266,907.5	1,266,907.5	F cal = 1.336
Error	13	12,331,770.9	948,597.7	
Total	14	13,598,678.4		

$$\begin{aligned}
SST &= (2100)^2 + (2930)^2 + \dots + (3121)^2 - T_{..}^2/15 \\
SST &= 94,808,652.0 - 81,209,973.6 \\
SST &= 13,598,678.4 \\
SSCAT &= (25,323)^2/(10) + (9579)^2/(5) - 81,209,973.6 \\
SSCAT &= 82,476,881.1 - 81,209,973.6 \\
SSCAT &= 1,266,907.5 \\
SSERR &= SST - SSCAT \\
SSERR &= 12,331,770.9 \\
F_{1, 13; .95} &= 4.67 > F_{cal} = 1.336
\end{aligned}$$

Therefore, we can not reject the null hypothesis or conclude that S sand has an effect on the cycles to failure of these circuit breakers under these test conditions (clean versus S sand environment).

.....

6. Comparison of Cycles to Failure of Standard Circuit Breakers Exposed, During Cycling, to a Clean Environment and a Blowing Desert Sand Environment

CL		DE	
Specimen No.	Cycles to Failure	Specimen No.	Cycles to Failure
1	2100	31	1087
2	2930	32	974
3	2945	33	219
4	2917	34	111
5	2844	35	1081
6	3478		$T_2 = \frac{3472}{5}$
7	3313		
8	2200		
9	1651		
10	945		
	$T_1 = \frac{25,323}{10}$		
	$T_{..} = 28,795$		

Observations: N = 15
K = 2

Mean Cycles to Failure

CL → 25,323/(10) = 2523.3

DE → 3472/(5) = 694.4

Source	d.f.	SS	MS	F ratio (Cat ÷ Err)
Catalyst	1	11,259,588.50	11,259,588.50	F cal = 22.11
Error	13	6,619,126.83	509,163.60	
Total	14	17,878,715.33		

$$\begin{aligned}
 SST &= (2100)^2 + (2930)^2 + \dots + (1081)^2 - T..^2/15 \\
 SST &= 73,155,517 - 55,276,801.67 \\
 SST &= 17,878,715.33 \\
 SSCAT &= (25,323)^2/(10) + (3472)^2/(5) - 55,276,801.2 \\
 SSCAT &= 11,259,588.5 \\
 SSERR &= SST - SSCAT \\
 SSERR &= 6,619,126.8 \\
 F_{1, 13; .95} &= 4.67 < F_{cal} = 22.11
 \end{aligned}$$

Therefore, we can reject the null hypothesis and conclude that DE sand does have an effect on the cycles to failure of these circuit breakers under these test conditions (clean versus DE sand environment).



7. Comparison of Cycles to Failure of Standard Circuit Breakers Exposed, During Cycling, to a Clean Environment and a Blowing 140-Mesh Silica Flour Sand Environment

CL		SIL	
Specimen No.	Cycles to Failure	Specimen No.	Cycles to Failure
1	2100	36	1434
2	2930	37	1627
3	2945	38	874
4	2917	39	16
5	2844	40	526
6	3478		$T_2 = 4477$
7	3313		
8	2200		
9	1651		
10	945		
	$T_1 = 25,323$		

$T.. = 29,800$

Observations: N = 15
K = 2

Mean Cycles to Failure

CL $\rightarrow 25,323/(10) = 2532.3$

SIL $\rightarrow 4477/(5) = 895.4$

Source	d.f.	SS	MS	F ratio (Cat \div Err)
Catalyst	1	8,931,472.0	8,931,472.0	F cal = 15.7
Error	13	7,406,583.3	569,737.2	
Total	14	16,338,055.3		

$$SST = (2100)^2 + (2930)^2 + \dots + (526)^2 - (29,800)^2/15$$

$$SST = 75,540,722 - 59,202,666.7$$

$$SST = 16,338,055.3$$

$$SSCAT = (25,323)^2/(10) + (4477)^2/(5) - 59,202,666.7$$

$$\begin{aligned}
 \text{SSCAT} &= 8,931,472.0 \\
 \text{SSERR} &= \text{SST} - \text{SSCAT} \\
 \text{SSERR} &= 7,406,583.3 \\
 F_{1, 13; .95} &= 4.67 < F_{\text{cal}} = 15.7
 \end{aligned}$$

Therefore, we can reject the null hypothesis and conclude that SIL sand does have an effect on the cycles to failure of these circuit breakers under these test conditions (clean versus SIL sand and dust environment).



8. Kolmogorov-Smirnov Goodness-of-Fit Test for a Normal Distribution of Cycles to Failure of Standard Circuit Breakers Exposed to Sand

Assume: Normal Distribution; $\alpha = 0.05$

Specimen No.	Cycles to Failure	Specimen No.	Cycles to Failure
11	991	26	2300
12	1319	27	449
13	640	28	650
14	1330	29	3059
15	1016	30	3121
16	1778	31	1087
17	2231	32	974
18	1428	33	219
19	685	34	111
20	1981	35	1081
21	908	36	1434
22	1831	37	1627
23	327	38	874
24	1673	39	16
25	1577	40	526
$T_1 = 19,715$		$T_2 = 17,528$	

$T_{..} = 37,243$

$$\bar{X} = 1241.4$$

$$s^2 = \frac{\sum (X - \bar{X})^2}{-1} = \frac{(X - 1241.4)^2}{29} = \frac{17,954,727.4}{29}$$

$$s^2 = 619,128.53$$

$$s = 786.85$$

X	$\frac{X - \bar{X}}{s}$	F(X)	$\hat{F}(X)$	$ F(X) - \hat{F}(X) $
16	-1.557	0.059	0.033	0.026
111	-1.437	0.075	0.066	0.009
219	-1.299	0.097	0.099	0.002
327	-1.162	0.123	0.132	0.009
449	-1.007	0.159	0.165	0.006
526	-0.909	0.181	0.198	0.017
640	-0.764	0.221	0.233	0.012
650	-0.752	0.228	0.266	0.038
685	-0.707	0.240	0.299	0.059
874	-0.467	0.320	0.332	0.012
908	-0.424	0.335	0.365	0.030
978	-0.335	0.368	0.398	0.030
991	-0.318	0.375	0.433	0.058
1016	-0.286	0.387	0.466	0.079
1081	-0.204	0.419	0.499	0.080
1087	-0.196	0.421	0.532	0.111 Max.
1319	0.099	0.540	0.565	0.025
1330	0.113	0.545	0.598	0.053
1428	0.237	0.594	0.633	0.039
1434	0.245	0.597	0.666	0.069
1577	0.427	0.666	0.699	0.033
1627	0.490	0.688	0.732	0.044
1673	0.549	0.709	0.765	0.056
1778	0.682	0.754	0.798	0.044
1831	0.749	0.774	0.833	0.059
1981	0.940	0.826	0.866	0.040
2231	1.258	0.897	0.899	0.002
2300	1.345	0.911	0.932	0.021
3059	2.310	0.990	0.966	0.024
3121	2.389	0.992	1.000	0.008

$$F(X) = 1 - P\left(Z > \frac{X - \bar{X}}{S}\right)$$

$d = \text{maximum absolute difference} = 0.111$

$d_{0.05} = 0.24$ (Table H-6, Reference 4)

$d_{\text{max.}} = 0.111 < d_{0.05} = 0.24$

Therefore, there is no reason to reject the assumption of normality with $\mu = 1241.4$ cycles and $\sigma = 786.85$ cycles.

.....

9. Comparison of Cycles to Failure of Completely sealed Circuit Breakers Exposed, During Cycling, to a Clean Environment and a Blowing Saigon Sand Environment

CL		S	
Specimen No.	Cycles to Failure	Specimen No.	Cycles to Failure
76	6594	61	5376
77	5415	62	11,099
78	4277	63	5193
79	6101	64	3890
80	6797	65	7121
$T_1 = 29,184$		$T_2 = 32,679$	

$T_{..} = 61,863$

Observations: $N = 10$
 $K = 2$

Mean Cycles to Failure

$CL \rightarrow 29,184/(5) = 5836.8$

$S \rightarrow 32,679/(5) = 6535.8$

Specimen No.	Cycles to Failure
--------------	-------------------

79	6101
80	6797

$$T_1 = 29,184$$

$$T_{..} = 40,600$$

Observations: N = 10
K = 2

Mean Cycles to Failure

$$CL \rightarrow 29,184/(5) = 5836.8$$

$$SIL \rightarrow 11,416/(5) = 2283.2$$

Specimen No.	Cycles to Failure
--------------	-------------------

69	2663
70	2674

$$T_2 = 11,416$$

Source	d.f.	SS	MS	F ratio (Cat ÷ Err)
Catalyst	1	31,570,182.2	31,570,182.2	F cal = 32.2
Error	8	7,841,217.8	980,152.2	
Total	9	39,411,400.0		

$$SST = (6594)^2 + (5415)^2 + \dots + (2674)^2 - (40,600)^2/10$$

$$SST = 204,247,400 - 164,836,000$$

$$SST = 39,411,400.0$$

$$SSCAT = 170,341,171.2 + 26,065,011 - 164,836,000$$

$$SSCAT = 31,570,182.2$$

$$SSERR = SST - SSCAT$$

$$SSERR = 7,841,217.8$$

$$F_{1, 8; .95} = 5.32 < F_{cal} = 32.2$$

Therefore, we can reject the null hypothesis and conclude that 140-mesh silica flour sand does have a significant effect on the cycles to failure of completely sealed circuit breakers when cycled during these test conditions (clean versus SIL sand and dust environment).



11. Comparison of Cycles to Failure of Completely Sealed Circuit Breakers Exposed, During Cycling, to a Clean Environment and a Blowing Desert Sand Environment

CL		DE	
Specimen No.	Cycles to Failure	Specimen No.	Cycles to Failure
76	6594	51	11,820
77	5415	52	7763
78	4277	53	1912
79	6101	54	4484
80	6797	55	6710
$T_1 = 29,184$		$T_2 = 32,689$	

$T.. = 61,873$

Observations: $N = 10$
 $K = 2$

Mean Cycles to Failure

$CL \rightarrow 29,184/(5) = 5836.8$

$DE \rightarrow 32,689/(5) = 6537.8$

Source	d.f.	SS	MS	F ratio (Cat ÷ Err)
Catalyst	1	1,228,502.5	1,228,502.5	F cal = .167
Error	8	59,224,553.6	7,403,069.2	
Total	9	60,453,056.1		

$SST = (6594)^2 + (5415)^2 + \dots + (6710)^2 - (61,873)^2/10$
 $SST = 443,279,869.0 - 382,826,812.9$
 $SST = 60,453,056.1$

Source	d.f.	SS	MS	F ratio (Cat ÷ Err)
Catalyst	2	54,975,719.8	27,487,859.9	F cal = 6.25
Error	12	52,749,144.6	4,395,762.1	
Total	14	107,724,864.4		

$$SST = (2300)^2 + (449)^2 + \dots + (7121) - T_{..}^2/15$$

$$SST = 405,804,577 - 298,079,712.6$$

$$SST = 107,724,864.4$$

$$SSCAT = (9579)^2/(5) + (24,609)^2/(5) + (32,679)^2/(5) - 298,079,712.6$$

$$SSCAT = 18,351,448.2 + 121,120,576.2 + 213,583,408 - 298,079,712.6$$

$$SSCAT = 54,975,719.8$$

$$SSERR = SST - SSCAT$$

$$SSERR = 52,749,144.6$$

$$F_{2, 12; .95} = 3.89 < F_{cal} = 6.25$$

Therefore, we can reject the null hypothesis and conclude that there is a significant difference in the cycles to failure of these circuit breakers caused by the sealing methods of the breakers when exposed to blowing Saigon sand. Duncan's multiple range test to determine the relative significance of the sealing methods of these circuit breakers against blowing Saigon sand is performed below:

STD	STD+	CS
$T_1 = 9579$	$T_2 = 24,609$	$T_3 = 32,679$
$\bar{y}_{.1} = 1915.8$	$\bar{y}_{.2} = 4921.8$	$\bar{y}_{.3} = 6535.8$
<hr/>		
$T_{..} = 66,867$		
$\bar{y}_{..} = 4457.8$		

$$\hat{a}_j = \bar{y}_{.j} - \bar{y}_{..}$$

$$\hat{a}_1 = 1915.8 - 4457.8 = -2542.0$$

$$\hat{a}_2 = 4921.8 - 4457.8 = 464.0$$

$$\hat{a}_3 = 6535.8 - 4457.8 = 2078.0$$

From the ANOVA for these data, it is known that there is a significant change in the cycles to failure for these seal methods.

STD	STD+	CS
$\bar{y}_{.1} = 1915.8$	$\bar{y}_{.2} = 4921.8$	$\bar{y}_{.3} = 6535.8$

$$MSE_{12} = 4,395,762.1$$

$$S_{\bar{y}_{.j}} = \sqrt{\frac{4,395,762.1}{5}} = 937.63$$

For $\alpha = 0.05$ and d.f. = 12, r_p is as follows where $p = 2, 3, \dots, K$. $K = 3$; therefore, $p = 2, 3$. (Note: r_p is the significant studentized range for the multiple range test (Reference 8)).

$p = 2$	3
$r_p = 3.08$	3.23
$LSR = 2887.9$	3028.5

where $LSR = (r_p) S_{y.j}$

$$CS - STD = 4620.0 > 3028.5, \text{ two means } \underline{\text{not}} \text{ same}$$

$$CS - STD+ = 1614.0 < 2887.9, \text{ two means } \underline{\text{are}} \text{ same}$$

$$STD+ - STD = 3006.0 > 2887.9, \text{ two means } \underline{\text{not}} \text{ same}$$

There is essentially no difference at the 95-percent confidence level between the two sealing methods for this test (Saigon sand sample) when compared to an unsealed circuit breaker.

.....

13. Comparison of Sealing Methods for Plunger-Type Circuit Breakers Exposed to Blowing Desert Sand, Using Cycles to Failure for Judgements

STD		STD+		CS	
Specimen No.	Cycles to Failure	Specimen No.	Cycles to Failure	Specimen No.	Cycles to Failure
31	1087	46	596	51	11,820
32	974	47	438	52	7763
33	219	48	774	53	1912
34	111	49	0	54	4484
35	1081	50	307	55	6710
$T_1 = 3472$		$T_2 = 2115$		$T_3 = 32,689$	

$T_{..} = 38,276$

Observations: $N = 15$
 $K = 3$

Mean Cycles to Failure

STD $\rightarrow 3472/(5) = 694.4$

STD+ $\rightarrow 2115/(5) = 423.0$

CS $\rightarrow 32,689/(5) = 6537.8$

Source	d.f.	SS	MS	F ratio (Cat \div Err)
Catalyst	2	119,349,600.7	59,674,800.4	F cal = 12.71
Error	12	56,342,396.2	4,695,199.7	
Total	14	175,691,996.9		

$$SST = (1087)^2 + (974)^2 + \dots + (6710)^2 - T_{..}^2/15$$

$$SST = 273,362,142 - 97,670,145.1$$

$$SST = 175,691,996.9$$

$$SSCAT = (3472)^2/(5) + (2115)^2/(5) + (32,689)^2/(5) - 97,670,145.1$$

$$SSCAT = 217,019,745.8 - 97,670,145.1$$

$$SSCAT = 119,349,600.7$$

$$SSERR = SST - SSCAT$$

$$SSERR = 56,342,396.2$$

$$F_{2, 12; .95} = 3.89 < F_{cal} = 12.71$$

Therefore, we can reject the null hypothesis and conclude that there is a significant difference in the cycles to failure of these circuit breakers caused by the sealing methods of the breakers when exposed to blowing desert sand. Duncan's multiple range test to determine the relative significance of the sealing methods of these circuit breakers against blowing desert sand is performed below:

STD	STD+	CS
$T_1 = 3472$	$T_2 = 2115$	$T_3 = 32,689$
$\bar{y}_{\cdot 1} = 694.4$	$\bar{y}_{\cdot 2} = 423.0$	$\bar{y}_{\cdot 3} = 6537.8$
<hr/>		
$T_{..} = 38,276$		
$\bar{y}_{..} = 2551.7$		

$$\hat{a}_j = \bar{y}_{\cdot j} - \bar{y}_{..}$$

$$\hat{a}_1 = 694.0 - 2551.7 = -1857.3$$

$$\hat{a}_2 = 423.0 - 2551.7 = -2128.7$$

$$\hat{a}_3 = 6537.8 - 2551.7 = 3986.1$$

From the ANOVA for these data, it is known that there is a significant change in the cycles to failure for these seal methods.

STD	STD+	CS
$\bar{y}_{\cdot 1} = 694.4$	$\bar{y}_{\cdot 2} = 423.0$	$\bar{y}_{\cdot 3} = 6537.8$

$$MSE_{12} = 4,695,199.7$$

$$S_{y \cdot j} = \sqrt{\frac{4,695,199.7}{5}} = 969.0$$

For $\alpha = 0.05$, d.f. = 12, and $p = 2, 3$, the values of r_p and LSR are as follows:

$$\begin{aligned}
 p &= 2 & 3 \\
 r_p &= 3.08 & 3.23 \\
 LSR &= 2984.5 & 3129.9
 \end{aligned}$$

where $LSR = (r_p) S_{y,j}$

$$CS - STD = 5843.4 > 2984.5, \text{ two means } \underline{\text{not}} \text{ same}$$

$$CS - STD+ = 6114.8 > 3129.9, \text{ two means } \underline{\text{not}} \text{ same}$$

$$STD - STD+ = 271.4 < 2984.5, \text{ two means } \underline{\text{are}} \text{ same}$$

There is essentially no difference at the 95-percent confidence level between the standard circuit breakers and the standard circuit breakers with a dust boot installed. There is a significant difference between the completely sealed circuit breaker and the standard circuit breaker with or without a dust boot.



14. Comparison of Sealing Methods for Plunger-Type Circuit Breakers Exposed to Blowing Silica Mesh Flour Sand, Using Cycles to Failure for Judgements

STD		STD+		CS	
Specimen No.	Cycles to Failure	Specimen No.	Cycles to Failure	Specimen No.	Cycles to Failure
36	1434	71	317	66	3281
37	1627	72	2465	67	2035
38	874	73	1766	68	763
39	16	74	712	69	2663
40	526	75	2603	70	2674
$T_1 = 4477$		$T_2 = 7863$		$T_3 = 11,416$	

$$T.. = 23,756$$

Observations: $N = 15$
 $K = 3$

Mean Cycles to Failure

$$STD \rightarrow 4477/(5) = 895.4$$

STD + 7863/(5) = 1572.6

CS + 11,416/(5) = 2283.2

Source	d.f.	SS	MS	F ratio (Cat ÷ Err)
Catalyst	2	4,815,901.7	2,407,950.9	F cal = 3.00
Error	12	9,613,445.2	801,120.4	
Total	14	14,429,346.9		

$$SST = (1434)^2 + (1627)^2 + \dots + (2674)^2 - T..^2/15$$

$$SST = 52,052,516 - 37,623,169.1$$

$$SST = 14,429,346.9$$

$$SSCAT = (4477)^2/(5) + (7863)^2/(15) + (11,416)^2/(5) - 37,623,169.1$$

$$SSCAT = 4,008,705.8 + 12,365,353.8 + 26,065,011.2 - 37,623,169.1$$

$$SSCAT = 4,815,901.7$$

$$SSERR = SST - SSCAT$$

$$SSERR = 9,613,445.2$$

$$F_{2, 12; .95} = 3.89 > F_{cal} = 3.00$$

Therefore, we can not reject the null hypothesis or conclude that there is any significant difference caused by the sealing methods of the circuit breakers on their cycles to failure when exposed to blowing silica mesh flour sand.



15. Comparison of Cycles to Failure of Standard Circuit Breakers Exposed, During Cycling, to Blowing Saigon, Desert, and 140-Mesh Silica Flour Sand Environments

S		DE		SIL	
Specimen No.	Cycles to Failure	Specimen No.	Cycles to Failure	Specimen No.	Cycles to Failure
26	2300	31	1087	36	1434
27	449	32	974	37	1627

Specimen No.	Cycles to Failure	Specimen No.	Cycles to Failure	Specimen No.	Cycles to Failure
28	650	33	219	38	874
29	3059	34	111	39	16
30	3121	35	1081	40	526
$T_1 = 9579$		$T_2 = 3472$		$T_3 = 4477$	

$$T.. = 17,528$$

Observations: N = 15
K = 3

Mean Cycles to Failure

$$S \rightarrow 9579/(5) = 1915.8$$

$$DE \rightarrow 3472/(5) = 694.4$$

$$SIL \rightarrow 4477/(5) = 895.4$$

Source	d.f.	SS	MS	F ratio (Cat ÷ Err)
Catalyst	2	4,289,058.5	2,144,529.3	F cal = 2.75
Error	12	9,344,493.2	778,707.7	
Total	14	13,633,551.7		

$$SST = (2300)^2 + (449)^2 + \dots + (526)^2 - T..^2/15$$

$$SST = 34,115,604.0 - 20,482,052.3$$

$$SST = 13,633,551.7$$

$$SSCAT = (9579)^2/(5) + (3472)^2/(5) + (4477)^2/(5) - T..^2/15$$

$$SSCAT = 18,351,448.2 + 2,410,956.8 + 4,008,705.8 - 20,482,052.3$$

$$SSCAT = 4,289,058.5$$

$$SSERR = SST - SSCAT$$

$$SSERR = 9,344,493.2$$

$$F_{2, 12; .95} = 3.89 > F_{cal} = 2.75$$

Therefore, we can not reject the null hypothesis or conclude that there is any significant difference for these sand samples when testing standard circuit breakers.

.....

16. Comparison of Cycles to Failure of Standard Circuit Breakers Plus Dust Boots Exposed, During Cycling, to Blowing Saigon, Desert, and 140-Mesh Silica Flour Sand Environments

S		DE		SIL	
Specimen No.	Cycles to Failure	Specimen No.	Cycles to Failure	Specimen No.	Cycles to Failure
61	7642	46	596	71	317
62	3299	47	438	72	2465
63	4853	48	774	73	1766
64	5858	49	0	74	712
65	<u>2957</u>	50	<u>307</u>	75	<u>2603</u>
$T_1 = 24,609$		$T_2 = 2115$		$T_3 = 7863$	

$T_{..} = 34,587$

Observation: N = 15
K = 3

Mean Cycles to Failure

$S \rightarrow 24,609/(5) = 4921.8$

$DE \rightarrow 2115/(5) = 423.0$

$SIL \rightarrow 7863/(5) = 1572.6$

Source	d.f.	SS	MS	F ratio (Cat ÷ Err)
Catalyst	2	54,629,870.4	27,314,935.2	F cal = 16.95
Error	<u>12</u>	<u>19,333,020.0</u>	1,611,085.0	
Total	14	73,962,890.4		

$$SST = (7642)^2 + (3299)^2 + \dots + (526)^2 - T_{..}^2/15$$

$$SST = 153,713,595 - 79,750,704.6$$

$$SST = 73,962,890.4$$

$$SSCAT = (24,609)^2/(5) + (2115)^2/(5) + (7863)^2/(5) - T_{..}^2/15$$

$$SSCAT = 121,120,576.2 + 894,645.0 + 12,365,353.8 - 79,750,704.6$$

$$SSCAT = 54,629,870.4$$

$$SSERR = SST - SSCAT$$

$$SSERR = 19,333,020.0$$

$$F_{2, 12; .95} = 3.89 < F_{cal} = 16.95$$

Therefore, we can reject the null hypothesis and conclude that there is a significant difference between the effects of the sand samples on the cycles to failure for the standard circuit breaker plus a dust boot. Duncan's multiple range test follows to determine the relative order of significance:

S	DE	SIL
$T_1 = 24,609$	$T_2 = 2115$	$T_3 = 7863$
$\bar{y}_{.1} = 4921.8$	$\bar{y}_{.2} = 423.0$	$\bar{y}_{.3} = 1572.6$
<hr/>		
$T_{..} = 34,587$		
$\bar{y}_{..} = 2305.8$		

$$\hat{a}_j = \bar{y}_{.j} - \bar{y}_{..}$$

$$\hat{a}_1 = 4921.8 - 2305.8 = 2616.0$$

$$\hat{a}_2 = 423.0 - 2305.8 = -1882.8$$

$$\hat{a}_3 = 1572.6 - 2305.8 = -733.2$$

Specimen No.	Cycles to Failure	Specimen No.	Cycles to Failure	Specimen No.	Cycles to Failure
59	3890	54	4484	69	2663
60	7121	55	6710	70	2674
$T_1 = 32,679$		$T_2 = 32,689$		$T_3 = 11,416$	

$$T_{..} = 76,784$$

Observations: N = 15
K = 3

Mean Cycles to Failure

$$S \rightarrow 32,679/(5) = 6535.8$$

$$DE \rightarrow 32,689/(5) = 6537.8$$

$$SIL \rightarrow 11,416/(5) = 2283.2$$

Source	d.f.	SS	MS	F ratio (Cat ÷ Err)
Catalyst	2	60,310,386.5	30,155,193.3	F cal = 3.98
Error	12	91,027,472.4	7,585,622.7	
Total	14	151,337,858.9		

$$SST = (5376)^2 + (11,099)^2 + \dots + (2674)^2 - T_{..}^2/15$$

$$SST = 543,390,036 - 393,052,177.1$$

$$SST = 151,337,858.9$$

$$SSCAT = (32,679)^2/(5) + (32,689)^2/(5) + (11,416)^2/(5) - T_{..}^2/15$$

$$SSCAT = 213,583,408.2 + 213,714,144.2 + 26,065,011.2 - 393,052,177.1$$

$$SSCAT = 60,310,386.5$$

$$SSERR = SST - SSCAT$$

$$SSERR = 91,027,472.4$$

$$F_{2, 12; .95} = 3.89 < F_{cal} = 3.98$$

Therefore, we can reject the null hypothesis and conclude that there is a significant difference between the effects of the sand samples on the cycles to failure of the completely sealed circuit breakers. Duncan's multiple range test to determine the relative order of significance follows:

S	DE	SIL
$T_3 = 32,679$	$T_2 = 32,689$	$T_3 = 11,416$
$\bar{y}_{\cdot 1} = 6535.8$	$\bar{y}_{\cdot 2} = 6537.8$	$\bar{y}_{\cdot 3} = 2283.2$
$T_{..} = 76,784$ $\bar{y}_{..} = 5118.9$		

$$\hat{a}_j = \bar{y}_{\cdot j} - \bar{y}_{..}$$

$$\hat{a}_1 = 6535.8 - 5118.9 = 1416.87$$

$$\hat{a}_2 = 6537.8 - 5118.9 = 1418.87$$

$$\hat{a}_3 = 2283.2 - 5118.9 = 2835.73$$

S	DE	SIL
$\bar{y}_{\cdot 1} = 6535.8$	$\bar{y}_{\cdot 2} = 6537.8$	$\bar{y}_{\cdot 3} = 2283.2$

$$MSE_{12} = 7,585,622.7$$

$$S_{y \cdot j} = \sqrt{\frac{7,585,622.7}{5}} = 1231.72$$

For $\alpha = 0.05$, d.f. = 12, and $p = 2, 3$, the values of r_p and LSR are as follows:

$p = 2$	3
$r_p = 3.08$	3.23
$LSR = 3719.79$	3978.46

where $LSR = (r_p) S_{y \cdot j}$

DE - SIL = 4254.6 > 3978.46, two means not same

DE - S = 2 < 3719.79, two means are same

S - SIL = 4252.6 > 3719.79, two means not same

It appears that 140-mesh silica flour causes the most significant effect on the cycles to failure of the completely sealed circuit breakers. Silica mesh flour also causes a much shorter cycle to failure of these circuit breakers than the other sand samples tested (Saigon and desert sand samples).

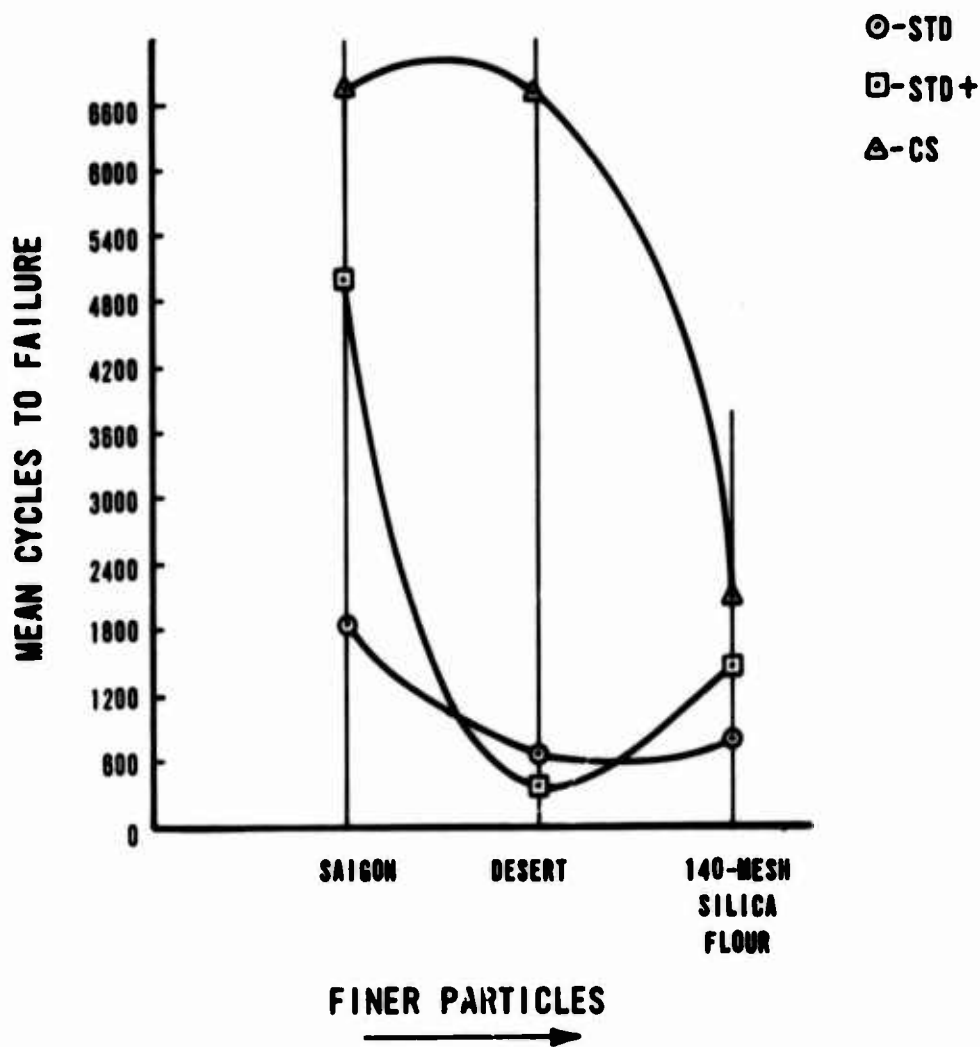

Figure 19. Mean Cycles to Failure Versus Sand Samples.

APPENDIX III
ANALYSIS OF THE EFFECT OF CYCLING
ON THE FORCE TO OPEN AND CLOSE
PLUNGER-TYPE CIRCUIT BREAKERS

This appendix contains the one-way classification analysis of variance for the effect of cycling on the force to open and close plunger-type circuit breakers.

1. Comparison of Effect of Cycling on the Force To Open Standard Circuit Breakers Exposed to a Clean Environment

Cycled (C)		Noncycled (NC)	
Specimen No.	Force To Open (lb)	Specimen No.	Force To Open (lb)
1	8.50	1	5.75
2	8.50	2	4.00
4	7.50	3	4.25
5	7.75	4	3.75
6	7.00	5	4.00
7	8.00		
8	16.25		
10	8.25		
	$T_1 = 71.75$		$T_2 = 21.75$

$T_{..} = 93.50$

Observations: $N = 13$
 $K = 2$

Mean Force To Open

$C \rightarrow 71.75/(8) = 8.97$

$NC \rightarrow 21.75/(5) = 4.35$

Source	d.f.	SS	MS	F ratio (Cat ÷ Err)
Catalyst	1	65.64	65.64	
Error	11	65.01	5.91	$F_{cal} = 11.11$
Total	12	130.65		

$$\begin{aligned}
SST &= (8.50)^2 + (8.50)^2 + \dots + (4.00)^2 - T..^2/13 \\
SST &= 803.13 - 672.49 \\
SST &= 130.65 \\
SSCAT &= (71.75)^2/(8) + (21.75)^2/(5) - T..^2/13 \\
SSCAT &= 643.51 + 94.61 - 672.48 \\
SSCAT &= 65.64 \\
SSERR &= SST - SSCAT \\
SSERR &= 65.01 \\
F_{1, 11; .95} &= 4.84 < F_{cal} = 11.11
\end{aligned}$$

Therefore, we can reject the null hypothesis and conclude that there is a significant difference caused by cycling on the force to open standard circuit breakers exposed to a clean environment.



2. Comparison of Effect of Cycling on the Force To Open Standard Circuit Breakers Exposed to a Blowing Virginia Beach Sand Environment

Cycled		Noncycled	
Specimen No.	Force To Open (lb)	Specimen No.	Force To Open (lb)
11	9.75	6	4.00
12	20.00	7	5.50
13	12.00	8	7.00
15	12.50	9	9.50
	<u>T₁ = 54.25</u>	10	8.50
			<u>T₂ = 34.50</u>

T.. = 88.75

Observations: N = 9
K = 2

Mean Force To Open

$$C \rightarrow 54.25/(4) = 13.56$$

$$NC \rightarrow 34.50/(5) = 6.90$$

Source	d.f.	SS	MS	F ratio (Cat ÷ Err)
Catalyst	1	98.65	98.65	F cal = 8.71
Error	7	79.24	11.32	
Total	8	177.89		

$$SST = (9.75)^2 + (20.00)^2 + \dots + (8.50)^2 - T..^2/9$$

$$SST = 1053.06 - 875.17$$

$$SST = 177.89$$

$$SSCAT = (54.25)^2/(4) + (34.50)^2/(5) - T..^2/9$$

$$SSCAT = 735.77 + 238.05 - 875.17$$

$$SSCAT = 98.65$$

$$SSERR = SST - SSCAT$$

$$SSERR = 79.24$$

$$F_{1, 7; .95} = 5.59 < F_{cal} = 8.71$$

Therefore, we can reject the null hypothesis and conclude that there is a significant difference caused by cycling on the force to open standard circuit breakers when exposed to blowing Virginia Beach sand.



3. Comparison of Effect of Cycling on the Force To Open Standard Circuit Breakers Exposed to a Blowing Da Nang Sand Environment

Cycled		Noncycled	
Specimen No.	Force To Open (lb)	Specimen No.	Force To Open (lb)
16	14.50	11	6.75
17	9.25	12	4.25
18	10.50	13	7.00
19	13.00	14	8.25
20	9.50	15	5.50
$T_1 = 56.75$		$T_2 = 31.75$	

$T_{..} = 88.50$

Observations: N = 10
K = 2

Mean Force To Open

C → $56.75/(5) = 11.35$

NC → $31.75/(5) = 6.35$

Source	d.f.	SS	MS	F ratio (Cat ÷ Err)
Catalyst	1	62.49	62.49	F cal = 16.36
Error	8	30.53	3.82	
Total	9	93.02		

$$SST = (14.50)^2 + (9.25)^2 + \dots + (5.50)^2 - T_{..}^2/10$$

$$SST = 876.25 - 783.23$$

$$SST = 93.02$$

$$SSCAT = (56.75)^2/(5) + (31.75)^2/(5) - T_{..}^2/10$$

$$SSCAT = 644.11 + 201.61 - 783.23$$

$$SSCAT = 62.49$$

$$\begin{aligned}
 SSERR &= SST - SSCAT \\
 SSERR &= 30.53 \\
 F_{1, 8; .95} &= 5.32 < F_{cal} = 16.36
 \end{aligned}$$

Therefore, we can reject the null hypothesis and conclude that there is a significant difference caused by cycling on the force to open standard circuit breakers when exposed to Da Nang sand.



4. Comparison of Effect of Cycling on the Force To Open Standard Circuit Breakers Exposed to a Blowing Fort Benning Sand Environment

Cycled		Noncycled	
Specimen No.	Force To Open (lb)	Specimen No.	Force To Open (lb)
21	19.00	16	5.00
22	12.25	17	5.75
23	12.50	18	5.75
25	20.00	19	8.75
	$T_1 = 63.75$	20	8.75
			$T_2 = 34.00$
	$T.. = 97.75$		

Observations: N = 9
K = 2

Mean Force To Open

C → $63.75/(4) = 15.94$

NC → $34.00/(5) = 6.80$

Source	d.f.	SS	MS	F ratio (Cat ÷ Err)
Catalyst	1	185.55	185.55	$F_{cal} = 20.19$
Error	7	64.34	9.19	
Total	8	249.89		

Mean Force To Open

$C \rightarrow 65.50/(4) = 16.38$

$NC \rightarrow 50.50/(5) = 10.10$

Source	d.f.	SS	MS	F ratio (Cat ÷ Err)
Catalyst	1	87.50	87.50	F cal = 2.90
Error	7	211.39	30.20	
Total	8	298.89		

$$SST = (20.00)^2 + (20.00)^2 + \dots + (6.00)^2 - T..^2/9$$
$$SST = 1794.00 - 1495.11$$
$$SST = 298.89$$
$$SSCAT = (65.50)^2/(4) + (50.50)^2/(5) - T..^2/9$$
$$SSCAT = 1072.56 + 510.05 - 1495.11$$
$$SSCAT = 87.50$$
$$SSERR = SST - SSCAT$$
$$SSERR = 211.39$$
$$F_{1, 7; .95} = 5.59 > F_{cal} = 2.90$$

Therefore, we can not reject the null hypothesis or conclude that there is a significant difference caused by cycling on the force to open standard circuit breakers when exposed to Saigon sand.



6. Comparison of Effect of Cycling on the Force To Open Standard Circuit Breakers Exposed to a Blowing Desert Sand Environment

Cycled		Noncycled	
Specimen No.	Force To Open (lb)	Specimen No.	Force To Open (lb)
31	13.00	26	5.25
32	9.50	27	6.25
33	9.00	28	4.75
34	10.00	29	7.50
35	14.00	30	7.50
$T_1 = 55.50$		$T_2 = 31.25$	

$$T_{..} = 86.75$$

Observations: $N = 10$
 $K = 2$

Mean Force To Open

$$C \rightarrow 55.50/(5) = 11.10$$

$$NC \rightarrow 31.25/(5) = 6.25$$

Source	d.f.	SS	MS	Fratio (Cat ÷ Err)
Catalyst	1	58.79	58.79	$F_{cal} = 17.71$
Error	8	26.58	3.32	
Total	9	85.37		

$$SST = (13.00)^2 + (9.50)^2 + \dots + (7.50)^2 - T_{..}^2/10$$

$$SST = 837.94 - 752.57$$

$$SST = 85.37$$

$$SSCAT = (55.00)^2/(5) + (31.25)^2/(5) - T_{..}^2/10$$

$$SSCAT = 616.05 + 195.31 - 752.57$$

$$SSCAT = 58.79$$

$$\begin{aligned}
 SSERR &= SST - SSCAT \\
 SSERR &= 26.58 \\
 F_{1,8; .95} &= 5.32 < F_{cal} = 17.71
 \end{aligned}$$

Therefore, we can reject the null hypothesis and conclude that there is a significant difference caused by cycling on the force to open standard circuit breakers when exposed to desert sand.



7. Comparison of Effect of Cycling on the Force To Open Standard Circuit Breakers Exposed to a Blowing 140-Mesh Silica Flour Sand Environment

Cycled		Noncycled	
Specimen No.	Force To Open (lb)	Specimen No.	Force To Open (lb)
36	12.00	31	9.50
37	17.00	32	6.75
38	11.50	33	10.00
39	9.50	34	6.50
40	12.00	35	10.00
T ₁ = 62.00		T ₂ = 42.75	
T.. = 104.75			

Observations: N = 10
K = 2

Mean Force To Open

C → 62.00/(5) = 12.40

NC → 42.75/(5) = 8.55

Source	d.f.	SS	MS	F ratio (Cat ÷ Err)
Catalyst	1	37.05	37.05	F _{cal} = 6.85
Error	8	43.25	5.41	
Total	9	80.30		

$$\begin{aligned}
SST &= (12.00)^2 + (17.00)^2 + \dots + (10.00)^2 - T_{..}^2/10 \\
SST &= 1177.56 - 1097.26 \\
SST &= 80.30 \\
SSCAT &= (62.00)^2/(5) + (42.75)^2/(5) - T_{..}^2/10 \\
SSCAT &= 768.80 + 365.51 - 1097.26 \\
SSCAT &= 37.05 \\
SSERR &= SST - SSCAT \\
SSERR &= 43.25 \\
F_{1, 8; .95} &= 5.32 < F_{cal} = 6.85
\end{aligned}$$

Therefore, we can reject the null hypothesis and conclude that there is a significant difference caused by cycling on the force to open standard circuit breakers when exposed to 140-mesh silica flour sand.



8. Comparison of Effect of Cycling on the Force To Open Standard Circuit Breakers Plus Dust Boots Exposed to a Blowing Desert Sand Environment

Cycled		Noncycled	
Specimen No.	Force To Open (lb)	Specimen No.	Force To Open (lb)
46	10.00	46	12.00
47	10.00	47	12.00
48	11.00	48	10.50
49	10.00	49	8.75
50	9.00	50	8.00
	$T_1 = 50.00$		$T_2 = 51.25$

$T_{..} = 101.25$

Observations: N = 10
K = 2

Mean Force To Open

$C \rightarrow 50.00/(5) = 10.00$

$NC \rightarrow 51.25/(5) = 10.25$

Source	d.f.	SS	MS	F ratio (Cat ÷ Err)
Catalyst	1	0.14	0.14	F cal = 0.072
Error	8	15.50	1.94	
Total	9	15.64		

$$SST = (10.00)^2 + (10.00)^2 + \dots + (8.00)^2 - T..^2/10$$

$$SST = 1040.81 - 1025.17$$

$$SST = 15.64$$

$$SSCAT = (50.00)^2/(5) + (51.25)^2/(5) - T..^2/10$$

$$SSCAT = 500.00 + 525.31 - 1025.17$$

$$SSCAT = 0.14$$

$$SSERR = SST - SSCAT$$

$$SSERR = 15.50$$

$$F_{1, 8; .95} = 5.32 > F_{cal} = 0.072$$

Therefore, we can not reject the null hypothesis or conclude that there is a significant difference caused by cycling on the force to open standard circuit breakers plus dust boots when exposed to desert sand.



9. Comparison of Effect of Cycling on the Force To Open Standard Circuit Breakers Plus Dust Boots Exposed to a Blowing Saigon Sand Environment

Cycled		Noncycled	
Specimen No.	Force To Open (lb)	Specimen No.	Force To Open (lb)
61	7.00	61	9.75
62	7.75	62	6.00
63	7.25	63	5.25
64	7.25	64	6.75
65	6.75	65	5.00
$T_1 = \overline{36.00}$		$T_2 = \overline{32.75}$	
$T.. = 68.75$			

Observations: N = 10
K = 2

Mean Force To Open

C → $36.00/(5) = 7.20$

NC → $32.75/(5) = 6.55$

Source	d.f.	SS	MS	F ratio (Cat ÷ Err)
Catalyst	1	1.05	1.05	Fcal = 0.55
Error	8	15.23	1.90	
Total	9	16.28		

$$SST = (7.00)^2 + (7.75)^2 + \dots + (5.00)^2 - T..^2/10$$

$$SST = 488.94 - 472.66$$

$$SST = 16.28$$

$$SSCAT = (36.00)^2/(5) + (32.75)^2/(5) - T..^2/10$$

$$SSCAT = 259.20 + 214.51 - 472.66$$

$$SSCAT = 1.05$$

$$\begin{aligned}
 SSERR &= SST - SSCAT \\
 SSERR &= 15.23 \\
 F_{1, 8; .95} &= 5.32 > F_{cal} = 0.55
 \end{aligned}$$

Therefore, we can not reject the null hypothesis or conclude that there is a significant difference caused by cycling on the force to open standard circuit breakers plus dust boots when exposed to Saigon sand.



10. Comparison of Effect of Cycling on the Force To Open Standard Circuit Breakers Plus Dust Boots Exposed to a Blowing 140-Mesh Silica Flour Sand Environment

Cycled		Noncycled	
Specimen No.	Force To Open (lb)	Specimen No.	Force To Open (lb)
72	7.50	41	5.50
74	10.00	42	5.00
75	7.50	43	2.50
	$T_1 = 25.00$	44	6.25
		45	4.25
			$T_2 = 23.50$

$T_{..} = 48.50$

Observations: N = 8
K = 2

Mean Force To Open

C → $25.00/(3) = 8.33$

NC → $23.50/(5) = 4.70$

Source	d.f.	SS	MS	F ratio (Cat ÷ Err)
Catalyst	1	24.75	24.75	F cal = 12.13
Error	6	12.25	2.04	
Total	7	37.00		

$$\begin{aligned}
SST &= (7.50)^2 + (10.00)^2 + \dots + (4.25)^2 - T_{..}^2/8 \\
SST &= 331.13 - 294.03 \\
SST &= 37.00 \\
SSCAT &= (25.00)^2/(3) + (23.50)^2/(5) - T_{..}^2/8 \\
SSCAT &= 208.33 + 110.45 - 294.03 \\
SSCAT &= 24.75 \\
SSERR &= SST - SSCAT \\
SSERR &= 12.25 \\
F_{1, 6; .95} &= 5.99 < F_{cal} = 12.13
\end{aligned}$$

Therefore, we can reject the null hypothesis and conclude that there is a significant difference caused by cycling on the force to open standard circuit breakers plus dust boots when exposed to 140-mesh silica flour sand.



11. Comparison of Effect of Cycling on the Force To Open Completely Sealed Circuit Breakers Exposed to a Blowing Saigon Sand Environment

Cycled		Noncycled	
Specimen No.	Force To Open (lb)	Specimen No.	Force To Open (lb)
56	11.50	56	6.00
57	3.25	57	7.50
	T ₁ = 14.75	58	7.75
		59	7.75
		60	4.25
			T ₂ = 33.25

T_{..} = 48.00

Observations: N = 7
K = 2

Mean Force To Open

C → 14.75/(2) = 7.38

NC → 33.25/(5) = 6.65

Source	d.f.	SS	MS	F ratio (Cat ÷ Err)
Catalyst	1	0.75	0.75	F cal = 0.09
Error	5	43.36	8.67	
Total	6	44.11		

$$\begin{aligned} SST &= (11.50)^2 + (3.25)^2 + \dots + (4.25)^2 - T..^2/7 \\ SST &= 373.25 - 329.14 \\ SST &= 44.11 \\ SSCAT &= (14.75)^2/(2) + (33.25)^2/(5) - T..^2/7 \\ SSCAT &= 108.78 + 221.11 - 329.14 \\ SSCAT &= 0.75 \\ SSERR &= SST - SSCAT \\ SSERR &= 43.36 \\ F_{1, 5; .95} &= 6.61 > F_{cal} = 0.09 \end{aligned}$$

Therefore, we can not reject the null hypothesis or conclude that there is a significant difference caused by cycling on the force to open completely sealed circuit breakers when exposed to Saigon sand.



12. Comparison of Effect of Cycling on the Force To Open Completely Sealed Circuit Breakers Exposed to a Blowing Desert Sand Environment

No data available.

.....

13. Comparison of Effect of Cycling on the Force To Open Completely Sealed Circuit Breakers Exposed to a Blowing 140-Mesh Silica Flour Sand Environment

Cycled		Noncycled	
Specimen No.	Force To Open (lb)	Specimen No.	Force To Open (lb)
66	7.25	36	4.00
67	7.75	37	4.50
69	6.00	38	5.00
70	7.25	39	4.00
	$T_1 = 28.25$	40	4.00
			$T_2 = 21.50$

$T_{..} = 49.75$

Observations: $N = 9$
 $K = 2$

Mean Force To Open

$C \rightarrow 28.25/(4) = 7.06$

$NC \rightarrow 21.50/(5) = 4.30$

Source	d.f.	SS	MS	F ratio (Cat ÷ Err)
Catalyst	1	16.96	16.96	$F_{cal} = 48.05$
Error	7	2.47	0.353	
Total	8	19.43		

$SST = (7.25)^2 + (7.75)^2 + \dots + (4.00)^2 - T_{..}^2/9$
 $SST = 294.44 - 275.01$

$$\begin{aligned}
SST &= 19.43 \\
SSCAT &= (28.25)^2/(4) + (21.50)^2/(5) - T_{..}^2/9 \\
SSCAT &= 199.52 + 92.45 - 275.01 \\
SSCAT &= 16.96 \\
SSERR &= SST - SSCAT \\
SSERR &= 2.47 \\
F_{1, 7; .95} &= 5.59 < F_{cal} = 48.05
\end{aligned}$$

Therefore, we can reject the null hypothesis and conclude that there is a significant difference caused by cycling on the force to open completely sealed circuit breakers when exposed to 140-mesh silica flour sand.



14. Comparison of Effect of Cycling on the Force To Close Standard Circuit Breakers Exposed to a Clean Environment

Cycled		Noncycled	
Specimen No.	Force To Close (lb)	Specimen No.	Force To Close (lb)
1	6.50	1	6.00
2	6.50	2	6.50
4	7.25	3	6.25
5	7.25	4	6.00
6	7.00	5	7.50
7	5.75		
10	7.25		
	<u>T₁ = 47.50</u>		<u>T₂ = 32.25</u>

T_{..} = 79.75

Observations: N = 12
K = 2

Mean Force To Close

$$C \rightarrow 47.50/(7) = 6.79$$

$$NC \rightarrow 32.25/(5) = 6.45$$

Source	d.f.	SS	MS	F ratio (Cat ÷ Err)
Catalyst	1	0.32	0.32	F cal = 0.91
Error	<u>10</u>	<u>3.49</u>	0.35	
Total	11	3.81		

$$SST = (6.50)^2 + (6.50)^2 + \dots + (7.50)^2 - T..^2/12$$

$$SST = 533.82 - 530.01$$

$$SST = 3.81$$

$$SSCAT = (47.50)^2/(7) + (32.25)^2/(5) - T..^2/12$$

$$SSCAT = 322.32 + 208.01 - 530.01$$

$$SSCAT = 0.32$$

$$SSERR = SST - SSCAT$$

$$SSERR = 3.49$$

$$F_{1,10;.95} = 4.96 > F_{cal} = 0.91$$

Therefore, we can not reject the null hypothesis or conclude that there is a significant difference caused by cycling on the force to close standard circuit breakers when exposed to a clean environment during cycling.

.....

15. Comparison of Effect of Cycling on the Force To Close Standard Circuit Breakers Exposed to a Blowing Virginia Beach Sand Environment

Cycled		Noncycled	
Specimen No.	Force To Close (lb)	Specimen No.	Force To Close (lb)
11	5.75	6	6.50
12	7.50	7	6.00
13	9.50	8	7.50
15	6.75	9	9.00
	$T_1 = 29.50$	10	7.25
			$T_2 = 36.25$

$T_{..} = 65.76$

Observations: N = 9
K = 2

Mean Force To Close

C → $29.50/(4) = 7.38$

NC → $36.25/(5) = 7.25$

Source	d.f.	SS	MS	F ratio (Cat ÷ Err)
Catalyst	1	0.030	0.030	F cal = 0.016
Error	7	12.82	1.83	
Total	8	12.85		

$$\begin{aligned}
 SST &= (5.75)^2 + (7.50)^2 + \dots + (7.25)^2 - T_{..}^2/9 \\
 SST &= 493.19 - 480.34 \\
 SST &= 12.85 \\
 SSCAT &= (29.50)^2/(4) + (36.25)^2/(5) - T_{..}^2/9 \\
 SSCAT &= 217.56 + 262.81 - 480.34 \\
 SSCAT &= 0.030
 \end{aligned}$$

$SSERR = SST - SSCAT$ $SSERR = 12.82$ $F_{1, 7; .95} = 5.59 > F_{cal} = 0.016$
--

Therefore, we can not reject the null hypothesis or conclude that there is a significant difference caused by cycling on the force to close standard circuit breakers when exposed to Virginia Beach type sand during cycling.



16. Comparison of Effect of Cycling on the Force To Close Standard Circuit Breakers Exposed to a Blowing Da Nang Sand Environment

Cycled		Noncycled	
Specimen No.	Force To Close (lb)	Specimen No.	Force To Close (lb)
17	7.50	11	7.50
18	7.00	12	6.75
	T ₁ = 14.50	13	8.50
		14	6.50
		15	7.25
			T ₂ = 36.50

T.. = 51.00

Observations: N = 7
K = 2

Mean Force To Close

C → 14.50/(2) = 7.25

NC → 36.50/(5) = 7.30

Source	d.f.	SS	MS	F ratio (Cat ÷ Err)
Catalyst	1	0.01	0.01	F cal = 0.02
Error	5	2.54	0.51	
Total	6	2.55		

$$\begin{aligned}
SST &= (7.50)^2 + (7.00)^2 + \dots + (7.25)^2 - T..^2/7 \\
SST &= 374.12 - 371.57 \\
SST &= 2.55 \\
SSCAT &= (14.50)^2/(2) + (36.50)^2/(5) - T..^2/7 \\
SSCAT &= 105.13 + 266.45 - 371.57 \\
SSCAT &= 0.01 \\
SSERR &= SST - SSCAT \\
SSERR &= 2.54 \\
F_{1, 5; .95} &= 6.61 > F_{cal} = 0.02
\end{aligned}$$

Therefore, we can not reject the null hypothesis or conclude that there is a significant difference caused by cycling on the force to close standard circuit breakers when exposed to Da Nang type sand during testing.

.....

17. Comparison of Effect of Cycling on the Force To Close Standard Circuit Breakers Exposed to a Blowing Fort Benning Sand Environment

Cycled		Noncycled	
Specimen No.	Force To Close (lb)	Specimen No.	Force To Close (lb)
22	7.50	16	7.50
23	8.75	17	6.75
$T_1 =$	16.25	18	6.50

Specimen No.	Force To Close (lb)
--------------	---------------------

Specimen No.	Force To Close (lb)
--------------	---------------------

19	7.25
20	8.25

$$T_2 = 36.25$$

$$T_{..} = 52.50$$

Observations: $N = 7$
 $K = 2$

Mean Force To Close

$C \rightarrow 16.25/(2) = 8.13$

$NC \rightarrow 36.25/(5) = 7.25$

Source	d.f.	SS	MS	F ratio (Cat \div Err)
Catalyst	1	1.09	1.09	
Error	5	2.67	0.53	$F_{cal} = 2.06$
Total	6	3.76		

$$SST = (7.50)^2 + (8.75)^2 + \dots + (8.25)^2 - T_{..}^2/7$$

$$SST = 397.51 - 393.75$$

$$SST = 3.76$$

$$SSCAT = (16.25)^2/(2) + (36.25)^2/(5) - T_{..}^2/7$$

$$SSCAT = 132.03 + 262.81 - 393.75$$

$$SSCAT = 1.09$$

$$SSERR = SST - SSCAT$$

$$SSERR = 2.67$$

$$F_{1, 5; .95} = 6.61 > F_{cal} = 2.06$$

Therefore, we can not reject the null hypothesis or conclude that there is a significant difference caused by cycling on the force to close standard circuit breakers when exposed to Fort Benning type sand during testing.



18. Comparison of Effect of Cycling on the Force To Close Standard Circuit Breakers Exposed to a Blowing Saigon Sand Environment

Cycled		Noncycled	
Specimen No.	Force To Close (lb)	Specimen No.	Force To Close (lb)
27	8.00	21	6.75
30	8.00	22	8.25
	$T_1 = 16.00$	23	7.50
		24	8.75
		25	7.25
			$T_2 = 38.50$

$T.. = 54.50$

Observations: $N = 7$
 $K = 2$

Mean Force To Close

$C \rightarrow 16.00/(2) = 8.00$

$NC \rightarrow 38.50/(5) = 7.70$

Source	d.f.	SS	MS	F ratio (Cat ÷ Err)
Catalyst	1	0.13	0.13	$F_{cal} = 0.25$
Error	5	2.56	0.51	
Total	6	2.69		

$$\begin{aligned}
SST &= (8.00)^2 + (8.00)^2 + \dots + (7.25)^2 - T_{..}^2/7 \\
SST &= 427.01 - 424.32 \\
SST &= 2.69 \\
SSCAT &= (16.00)^2/(2) + (38.50)^2/(5) - T_{..}^2/7 \\
SSCAT &= 128.00 + 296.45 - 424.32 \\
SSCAT &= 0.13 \\
SSERR &= SST - SSCAT \\
SSERR &= 2.56 \\
F_{1, 5; .95} &= 6.61 > F_{cal} = 0.25
\end{aligned}$$

Therefore, we can not reject the null hypothesis or conclude that there is a significant difference caused by cycling on the force to close standard circuit breakers when exposed to Saigon sand during testing.



19. Comparison of Effect of Cycling on the Force To Close Standard Circuit Breakers Exposed to a Blowing Desert Sand Environment

<u>Cycled</u>		<u>Noncycled</u>	
<u>Specimen No.</u>	<u>Force To Close (lb)</u>	<u>Specimen No.</u>	<u>Force To Close (lb)</u>
31	8.25	26	6.75
32	7.25	27	6.00
33	11.75	28	5.75
34	10.00	29	6.25
	$T_1 = 37.25$	30	6.00
			$T_2 = 30.75$

T.. = 68.00

Observations: N = 9
K = 2

Mean Force To Close

C → 37.25/(4) = 9.31

NC → 30.75/(5) = 6.15

Source	d.f.	SS	MS	F ratio (Cat ÷ Err)
Catalyst	1	22.22	22.22	F cal = 12.55
Error	7	12.38	1.77	
Total	8	34.60		

$$\begin{aligned}
 SST &= (8.25)^2 + (7.25)^2 + \dots + (6.00)^2 - T..^2/9 \\
 SST &= 548.38 - 513.78 \\
 SST &= 34.60 \\
 SSCAT &= (37.25)^2/(4) + (30.75)^2/(5) - T..^2/9 \\
 SSCAT &= 346.89 + 189.11 - 513.78 \\
 SSCAT &= 22.22 \\
 SSERR &= SST - SSCAT \\
 SSERR &= 12.38 \\
 F_{1, 7; .95} &= 5.59 < F_{cal} = 12.55
 \end{aligned}$$

Therefore, we can reject the null hypothesis and conclude that there is a significant difference caused by cycling on the force to close standard circuit breakers when exposed to desert sand during test.



20. Comparison of Effects of Cycling on the Force To Close Standard Circuit Breakers Exposed to a Blowing 140-Mesh Silica Flour Sand Environment

Cycled		Noncycled	
Specimen No.	Force To Close (lb)	Specimen No.	Force To Close (lb)
36	6.25	31	7.50
37	6.50	32	7.50
38	6.25	33	7.25
39	6.75	34	7.75
40	6.00	35	6.75
$T_1 = 31.75$		$T_2 = 36.75$	

$T_{..} = 68.50$

Observations: N = 10
K = 2

Mean Force To Close

C → $31.75/(5) = 6.35$

NC → $36.75/(5) = 7.35$

Source	d.f.	SS	MS	F ratio (Cat ÷ Err)
Catalyst	1	2.49	2.49	F cal = 0.63
Error	8	31.42	3.93	
Total	9	33.91		

$$\begin{aligned}
 SST &= (6.25)^2 + (6.50)^2 + \dots + (6.75)^2 - T_{..}^2/10 \\
 SST &= 503.14 - 469.23 \\
 SST &= 33.91 \\
 SSCAT &= (31.75)^2/(5) + (36.75)^2/(5) - T_{..}^2/10
 \end{aligned}$$

$$\begin{aligned}
SSCAT &= 201.61 + 270.11 - 469.23 \\
SSCAT &= 2.49 \\
SSERR &= SST - SSCAT \\
SSERR &= 31.42 \\
F_{1, 8; .95} &= 5.32 > F_{cal} = 0.63
\end{aligned}$$

Therefore, we can not reject the null hypothesis or conclude that there is a significant difference caused by cycling on the force to close standard circuit breakers when exposed to 140-mesh silica flour sand during testing.



21. Comparison of Effects of Cycling on the Force To Close Standard Circuit Breakers Plus Dust Boots Exposed to a Blowing Saigon Sand Environment

<u>Cycled</u>		<u>Noncycled</u>	
<u>Specimen No.</u>	<u>Force To Close (lb)</u>	<u>Specimen No.</u>	<u>Force To Close (lb)</u>
61	5.00	61	6.50
62	6.00	62	6.00
63	5.75	63	6.25
64	5.00	64	6.25
65	5.50	65	6.75
	$T_1 = 27.25$		$T_2 = 31.75$
$T.. = 59.00$			

Observations: N = 10
K = 2

Mean Force To Close

C → 27.25/(5) = 5.45
NC → 31.75/(5) = 6.35

Source	d.f.	SS	MS	F ratio (Cat ÷ Err)
Catalyst	1	2.02	2.02	F cal = 0.40
Error	8	40.19	5.02	
Total	9	42.21		

$$\begin{aligned}
SST &= (5.00)^2 + (6.00)^2 + \dots + (6.75)^2 - T..^2/10 \\
SST &= 390.31 - 348.10 \\
SST &= 42.21 \\
SSCAT &= (27.25)^2/(5) + (31.75)^2/(5) - T..^2/10 \\
SSCAT &= 148.51 + 201.61 - 348.10 \\
SSCAT &= 2.02 \\
SSERR &= SST - SSCAT \\
SSERR &= 40.19 \\
F_{1, 8; .95} &= 5.32 > F_{cal} = 0.40
\end{aligned}$$

Therefore, we can not reject the null hypothesis or conclude that there is a significant difference caused by cycling on the force to close standard circuit breakers plus dust boots when exposed to Saigon sand during testing.



22. Comparison of Effects of Cycling on the Force To Close Standard Circuit Breakers Plus Dust Boots Exposed to a Blowing Desert Sand Environment

Cycled		Noncycled	
Specimen No.	Force To Close (lb)	Specimen No.	Force To Close (lb)
46	6.50	46	6.00
47	6.50	47	5.50
48	6.00	48	5.25

Specimen No.	Force To Close (lb)	Specimen No.	Force To Close (lb)
49	7.75	49	9.00
50	7.50	50	6.25
$T_1 = 34.25$		$T_2 = 32.00$	

$$T_{..} = 66.25$$

Observations: N = 10
K = 2

Mean Force To Close

$$C \rightarrow 34.25/(5) = 6.85$$

$$NC \rightarrow 32.00/(5) = 6.40$$

Source	d.f.	SS	MS	F ratio (Cat ÷ Err)
Catalyst	1	0.50	0.50	F cal = 0.35
Error	8	11.27	1.41	
Total	9	11.77		

$$SST = (6.50)^2 + (6.50)^2 + \dots + (6.25)^2 - T_{..}^2/10$$

$$SST = 450.68 - 438.91$$

$$SST = 11.77$$

$$SSCAT = (34.25)^2/(5) + (32.00)^2/(5) - T_{..}^2/10$$

$$SSCAT = 234.61 + 204.80 - 438.91$$

$$SSCAT = 0.50$$

$$SSERR = SST - SSCAT$$

$$SSERR = 11.27$$

$$F_{1, 8; .95} = 5.32 > F_{cal} = 0.35$$

Therefore, we can not reject the null hypothesis or conclude that there is a significant difference caused by cycling on the force to close standard circuit breakers plus dust boots when exposed to desert sand during testing.



23. Comparison of Effects of Cycling on the Force To Close Standard Circuit Breakers Plus Dust Boots Exposed to a Blowing 140-Mesh Silica Flour Sand Environment

<u>Cycled</u>		<u>Noncycled</u>	
<u>Specimen No.</u>	<u>Force To Close (lb)</u>	<u>Specimen No.</u>	<u>Force To Close (lb)</u>
72	6.00	41	5.50
74	6.75	42	7.50
75	8.50	43	5.75
	$T_1 = 21.25$	44	5.50
		45	6.00
			$T_2 = 30.25$

$T.. = 51.50$

Observations: N = 8
K = 2

Mean Force To Close

C → $21.25/(3) = 7.08$

NC → $30.25/(5) = 6.05$

<u>Source</u>	<u>d.f.</u>	<u>SS</u>	<u>MS</u>	<u>F ratio (Cat ÷ Err)</u>
Catalyst	1	2.00	2.00	$F_{cal} = 1.96$
Error	<u>6</u>	<u>6.09</u>	1.02	
Total	7	8.09		

$$\begin{aligned}
SST &= (6.00)^2 + (6.75)^2 + \dots + (6.00)^2 - T_{..}^2/8 \\
SST &= 339.62 - 331.53 \\
SST &= 8.09 \\
SSCAT &= (21.25)^2/(3) + (30.25)^2/(5) - T_{..}^2/8 \\
SSCAT &= 150.52 + 183.01 - 331.53 \\
SSCAT &= 2.00 \\
SSERR &= SST - SSCAT \\
SSERR &= 6.09 \\
F_{1, 6; .95} &= 5.99 > F_{cal} = 1.96
\end{aligned}$$

Therefore, we can not reject the null hypothesis or conclude that there is a significant difference caused by cycling on the force to close standard circuit breakers plus dust boots when exposed to 140-mesh silica flour sand during testing.



24. Comparison of Effects of Cycling on the Force To Close Completely Sealed Circuit Breakers Exposed to a Blowing Saigon Sand Environment

Cycled		Noncycled	
Specimen No.	Force To Close (lb)	Specimen No.	Force To Close (lb)
56	6.00	56	7.25
57	6.00	57	6.75
	$T_1 = 12.00$	58	6.75
		59	6.75
		60	7.25
		$T_2 = 34.75$	

$T_{..} = 46.75$

Observations: N = 7
K = 2

Mean Force To Close

C → 12.00/(2) = 6.00

NC → 34.75/(5) = 6.95

Source	d.f.	SS	MS	F ratio (Cat ÷ Err)
Catalyst	1	1.29	1.29	F cal = 21.50
Error	5	0.31	0.06	
Total	6	1.60		

$$\begin{aligned}
 SST &= (6.00)^2 + (6.00)^2 + \dots + (7.25)^2 - T..^2/7 \\
 SST &= 313.82 - 312.22 \\
 SST &= 1.60 \\
 SSCAT &= (12.00)^2/(2) + (34.75)^2/(5) - T..^2/7 \\
 SSCAT &= 72.00 + 241.51 - 312.22 \\
 SSCAT &= 1.29 \\
 SSERR &= SST - SSCAT \\
 SSERR &= 0.31 \\
 F_{1, 5; .95} &= 6.61 < F_{cal} = 21.50
 \end{aligned}$$

Therefore, we can reject the null hypothesis and conclude that there is a significant difference caused by cycling on the force to close completely sealed circuit breakers when exposed to Saigon sand during testing.



25. Comparison of Effects of Cycling on the Force To Close Completely Sealed Circuit Breakers Exposed to a Blowing Desert Sand Environment

No data available.

.....

26. Comparison of Effects of Cycling on the Force To Close Completely Sealed Circuit Breakers Exposed to a Blowing 140-Mesh Silica Flour Sand Environment

Cycled		Noncycled	
Specimen No.	Force To Close (lb)	Specimen No.	Force To Close (lb)
66	6.50	36	6.00
67	6.25	37	6.25
69	10.00	38	7.50
70	7.50	39	6.50
	$T_1 = 30.25$	40	6.00
			$T_2 = 32.25$

$T.. = 62.50$

Observations: N = 9
K = 2

Mean Force To Close

$C \rightarrow 30.25/(4) = 7.56$

$NC \rightarrow 32.25/(5) = 6.45$

Source	d.f.	SS	MS	F ratio (Cat ÷ Err)
Catalyst	1	2.74	2.74	F cal = 1.85
Error	7	10.35	1.48	
Total	8	13.09		

$$\begin{aligned}
SST &= (6.50)^2 + (6.25)^2 + \dots + (6.00)^2 - T_{..}^2/9 \\
SST &= 447.12 - 434.03 \\
SST &= 13.09 \\
SSCAT &= (30.25)^2/(4) + (32.25)^2/(5) - T_{..}^2/9 \\
SSCAT &= 228.76 + 208.01 - 434.03 \\
SSCAT &= 2.74 \\
SSERR &= SST - SSCAT \\
SSERR &= 10.35 \\
F_{1, 7; .95} &= 5.59 > F_{cal} = 1.85
\end{aligned}$$

Therefore, we can not reject the null hypothesis or conclude that there is a significant difference caused by cycling on the force to close completely sealed circuit breakers when exposed to 140-mesh silica flour sand during testing.



27. Comparison of Force To Open Cycled Standard Circuit Breakers With Dust Boots Exposed to Desert Sand

Note: This is the only such comparison that can be made with cycled circuit breakers due to a lack of data from these tests.

Preoperation		Postoperation	
Specimen No.	Force To Open (lb)	Specimen No.	Force To Open (lb)
46	5.25	46	10.00
47	4.50	47	10.00
48	3.00	48	11.00
49	4.50	49	10.00
50	3.25	50	9.00
	$T_1 = 20.50$		$T_2 = 50.00$
$T_{..} = 70.50$			

28. Comparison of Force To Close Cycled Standard Circuit Breakers With Dust Boots Exposed to Desert Sand

Note: This is the only such comparison that can be made with cycled circuit breakers due to a lack of data from these tests.

<u>Preoperation</u>		<u>Postoperation</u>	
<u>Specimen No.</u>	<u>Force To Close (lb)</u>	<u>Specimen No.</u>	<u>Force To Close (lb)</u>
46	6.00	46	6.50
47	6.25	47	6.50
48	5.50	48	6.00
49	6.25	49	7.75
50	6.50	50	7.50
	$T_1 = 30.50$		$T_2 = 34.25$
$T.. = 64.75$			

Observations: $N = 10$
 $K = 2$

Mean Force To Close

Preop $\rightarrow 30.50/(5) = 6.1$

Postop $\rightarrow 34.25/(5) = 6.85$

<u>Source</u>	<u>d.f.</u>	<u>SS</u>	<u>MS</u>	<u>F ratio (Cat \div Err)</u>
Catalyst	1	1.40	1.40	$F_{cal} = 4.00$
Error	8	2.78	0.35	
Total	9	4.18		

$$\begin{aligned}
 SST &= (6.00)^2 + (6.25)^2 + \dots + (7.50)^2 - T..^2/10 \\
 SST &= 423.44 - 419.26 \\
 SST &= 4.18
 \end{aligned}$$

$$\text{SSCAT} = (30.50)^2/(5) + (34.25)^2/(5) - T..^2/10$$

$$\text{SSCAT} = 186.05 + 234.61 - 419.26$$

$$\text{SSCAT} = 1.40$$

$$\text{SSERR} = \text{SST} - \text{SSCAT}$$

$$\text{SSERR} = 2.78$$

$$F_{1, 8; .95} = 5.32 > F_{\text{cal}} = 4.00$$

Therefore, we can not reject the null hypothesis or conclude that there is a significant difference between the preoperation and postoperation forces to close cycled standard circuit breakers when exposed, during cycling, to desert sand.

.....

APPENDIX IV
ANALYSIS OF THE EFFECT OF SAND
ON THE FORCE TO OPEN PLUNGER-TYPE
CIRCUIT BREAKERS

This appendix contains the one-way classification analysis of variance for the effect of various blowing sand samples on the force to open plunger-type circuit breakers.

1. Comparison of the Force To Open Noncycled Standard Circuit Breakers Exposed to Blowing Sands

VA		DA		FB	
Specimen No.	Force To Open (lb)	Specimen No.	Force To Open (lb)	Specimen No.	Force To Open (lb)
6	4.00	11	6.75	16	5.00
7	5.50	12	4.25	17	5.75
8	7.00	13	7.00	18	5.75
9	9.50	14	8.25	19	8.75
10	8.50	15	5.50	20	8.75
$T_1 = 34.50$		$T_2 = 31.75$		$T_3 = 34.00$	

S		DE		SIL	
Specimen No.	Force To Open (lb)	Specimen No.	Force To Open (lb)	Specimen No.	Force To Open (lb)
21	9.50	26	5.25	31	9.50
22	20.00	27	6.25	32	6.75
23	8.50	28	4.75	33	10.00
24	6.50	29	7.50	34	6.50
25	6.00	30	7.50	35	10.00
$T_4 = 50.50$		$T_5 = 31.25$		$T_6 = 42.75$	

$T_{..} = 179.75$

Observations: $N = 30$
 $K = 6$

Mean Force To Open

VA → 34.50/(5) = 6.90

DA → 31.75/(5) = 6.35

FB → 34.00/(5) = 6.80

S → 50.50/(5) = 10.10

DE → 31.25/(5) = 6.25

SIL → 42.75/(5) = 8.55

Source	d.f.	SS	MS	F ratio (Cat ÷ Err)
Catalyst	5	57.98	11.60	F cal = 1.45
Error	24	191.72	7.99	
Total	29	249.70		

$$SST = (4.00)^2 + (5.50)^2 + \dots + (10.00)^2 - T..^2/30$$

$$SST = 1933.45 - 1683.75$$

$$SST = 249.70$$

$$SSCAT = (34.50)^2/(5) + (31.75)^2/(5) + (34.00)^2/(5) + (50.50)^2/(5) \\ + (31.25)^2/(5) + (42.75)^2/(5) - T..^2/30$$

$$SSCAT = 238.05 + 201.61 + 231.20 + 510.05 + 195.13 \\ + 365.51 - 1683.75$$

$$SSCAT = 57.98$$

$$SSERR = SST - SSCAT$$

$$SSERR = 191.72$$

$$F_{5, 24; .95} = 2.62 > F_{cal} = 1.45$$

Therefore, we can not reject the null hypothesis or conclude that there is a significant difference in the forces required to open standard circuit breakers following exposure to the referenced sand samples.

.....

2. Comparison of the Force To Open Noncycled Standard Circuit Breakers Exposed to a Blowing Virginia Beach Sand Environment

CL		VA	
Specimen No.	Force To Open (lb)	Specimen No.	Force To Open (lb)
1	5.75	6	4.00
2	4.00	7	5.50
3	4.25	8	7.00
4	3.75	9	9.50
5	4.00	10	8.50
	$T_1 = 21.75$		$T_2 = 34.50$

$T_{..} = 56.25$

Observations: N = 10
K = 2

Mean Force To Open

CL $\rightarrow 21.75/(5) = 4.35$

VA $\rightarrow 34.50/(5) = 6.90$

Source	d.f.	SS	MS	F ratio (Cat \div Err)
Catalyst	1	16.25	16.25	F cal = 5.83
Error	8	22.28	2.79	
Total	9	38.53		

$$SST = (5.75)^2 + (4.00)^2 + \dots + (8.50)^2 - T_{..}^2/10$$

$$SST = 354.94 - 316.41$$

$$SST = 38.53$$

$$SSCAT = (21.75)^2/(5) + (34.50)^2/(5) - T_{..}^2/10$$

$$SSCAT = 94.61 + 238.05 - 316.41$$

$$SSCAT = 16.25$$

$$\begin{aligned}
 SSERR &= SST - SSCAT \\
 SSERR &= 22.28 \\
 F_{1, 8; .95} &= 5.32 < F_{cal} = 5.83
 \end{aligned}$$

Therefore, we can reject the null hypothesis and conclude that there is a significant difference between the force required to open the noncycled standard circuit breakers exposed to a clean atmosphere and those exposed to Virginia Beach sand.



3. Comparison of the Force To Open Noncycled Standard Circuit Breakers Exposed to a Blowing Da Nang Sand Environment

<u>CL</u>		<u>DA</u>	
Specimen No.	Force To Open (lb)	Specimen No.	Force To Open (lb)
1	5.75	11	6.75
2	4.00	12	4.25
3	4.25	13	7.00
4	3.75	14	8.25
5	4.00	15	5.50
	$T_1 = 21.75$		$T_2 = 31.75$

$T_{..} = 53.50$

Observations: N = 10
K = 2

Mean Force To Open

CL → $21.75/(5) = 4.35$

DA → $31.75/(5) = 6.35$

Source	d.f.	SS	MS	F ratio (Cat ÷ Err)
Catalyst	1	9.99	9.99	F cal = 6.7
Error	8	11.91	1.49	
Total	9	21.90		

$$\begin{aligned}
SST &= (5.75)^2 + (4.00)^2 + \dots + (5.50)^2 - T..^2/10 \\
SST &= 308.13 - 286.23 \\
SST &= 21.90 \\
SSCAT &= (21.75)^2/(5) + (31.75)^2/(5) - T..^2/10 \\
SSCAT &= 94.61 + 201.61 - 286.23 \\
SSCAT &= 9.99 \\
SSERR &= SST - SSCAT \\
SSERR &= 11.91 \\
F_{1, 8; .95} &= 5.32 < F_{cal} = 6.7
\end{aligned}$$

Therefore, we can reject the null hypothesis and conclude that there is a significant difference between the force required to open the noncycled standard circuit breakers exposed to a clean atmosphere and those exposed to blowing Da Nang sand.



4. Comparison of the Force To Open Noncycled Standard Circuit Breakers Exposed to a Blowing Fort Benning Sand Environment

CL		FB	
Specimen No.	Force To Open (lb)	Specimen No.	Force To Open (lb)
1	5.75	16	5.00
2	4.00	17	5.75

Specimen No.	Force To Open (lb)
3	4.25
4	3.75
5	4.00
	$T_1 = 21.75$

Specimen No.	Force To Open (lb)
18	5.75
19	8.75
20	8.75
	$T_2 = 34.00$

$$T_{..} = 55.75$$

Observations: $N = 10$
 $K = 2$

Mean Force To Open

$$CL \rightarrow 21.75/(5) = 4.35$$

$$FB \rightarrow 34.00/(5) = 6.80$$

Source	d.f.	SS	MS	F ratio (Cat ÷ Err)
Catalyst	1	15.01	15.01	
Error	8	15.64	1.95	$F_{cal} = 7.70$
Total	9	30.65		

$$SST = (5.75)^2 + (4.00)^2 + \dots + (8.75)^2 - T_{..}^2/10$$

$$SST = 341.45 - 310.80$$

$$SST = 30.65$$

$$SSCAT = (21.75)^2/(5) + (34.00)^2/(5) - T_{..}^2/10$$

$$SSCAT = 94.61 + 231.20 - 310.80$$

$$SSCAT = 15.01$$

$$SSERR = SST - SSCAT$$

$$SSERR = 15.64$$

$$F_{1, 8; .95} = 5.32 < F_{cal} = 7.70$$

Therefore, we can reject the null hypothesis and conclude that there is a significant difference between the force required to open the noncycled standard circuit breakers exposed to a clean atmosphere and those exposed to Fort Benning sand.



5. Comparison of the Force To Open Noncycled Standard Circuit Breakers Exposed to a Blowing Saigon Sand Environment

CL		S	
Specimen No.	Force To Open (lb)	Specimen No.	Force To Open (lb)
1	5.75	21	9.50
2	4.00	22	20.00
3	4.25	23	8.50
4	3.75	24	6.50
5	4.00	25	6.00
$T_1 = 21.75$		$T_2 = 50.50$	

$T_{..} = 72.25$

Observations: N = 10
K = 2

Mean Force To Open

CL $\rightarrow 21.75/(5) = 4.35$

S $\rightarrow 50.50/(5) = 10.10$

Source	d.f.	SS	MS	F ratio (Cat \div Err)
Catalyst	1	82.65	82.65	F cal = 4.96
Error	8	133.28	16.66	
Total	9	215.93		

$$\begin{aligned}
SST &= (5.75)^2 + (4.00)^2 + \dots + (6.00)^2 - T..^2/10 \\
SST &= 737.94 - 522.01 \\
SST &= 215.93 \\
SSCAT &= (21.75)^2/(5) + (50.50)^2/(5) - T..^2/10 \\
SSCAT &= 94.61 + 510.05 - 522.01 \\
SSCAT &= 82.65 \\
SSERR &= SST - SSCAT \\
SSERR &= 133.28 \\
F_{1, 8; .95} &= 5.32 > F_{cal} = 4.96
\end{aligned}$$

Therefore, we can not reject the null hypothesis in this case. However, specimen number 22 is suspect and should be examined for the possibility of rejecting it. That analysis follows:

Using the Dixon criterion described in Reference 7 and assuming that $\alpha = 0.05$, $r_{1-\alpha} = r_{.95} = 0.642$ as found in Table A-14 of Reference 7 for $n = 5$ and $r_{ij} = r_{10}$.

S	
Specimen Number	Force To Open (lb)
25	6.00
24	6.50
23	8.50
21	9.50
22	20.00

$$r_{10} = \frac{20.00 - 9.50}{20.00 - 6.00} = 0.75$$

$$r_{ij} = 0.75 > r_{10} = 0.642$$

Therefore, we can reject the data point 20.00 for specimen number 22 of the noncycled, sand-exposed standard circuit breakers and redo the ANOVA for these data points:

CL		S	
Specimen No.	Force To Open (lb)	Specimen No.	Force To Open (lb)
1	5.75	21	9.50
2	4.00	23	8.50
3	4.25	24	6.50
4	3.75	25	6.00
5	4.00		
	$T_1 = 21.75$		$T_2 = 30.50$

$$T_{..} = 52.25$$

Observations: $N = 9$
 $K = 2$

Mean Force To Open

$$CL \rightarrow 21.75/(5) = 4.35$$

$$S \rightarrow 30.50/(4) = 7.63$$

Source	d.f.	SS	MS	F ratio (Cat ÷ Err)
Catalyst	1	23.83	23.83	$F_{cal} = 15.47$
Error	7	10.77	1.54	
Total	8	34.60		

$$SST = (5.75)^2 + (4.00)^2 + \dots + (6.00)^2 - T_{..}^2/9$$

$$SST = 337.94 - 303.34$$

$$SST = 34.60$$

$$SSCAT = (21.75)^2/(5) + (30.50)^2/(4) - T_{..}^2/9$$

$$SSCAT = 94.61 + 232.56 - 303.34$$

$$SSCAT = 23.83$$

$$SSERR = SST - SSCAT$$

$$SSERR = 10.77$$

$$F_{1, 7; .95} = 5.59 < F_{cal} = 15.47$$

Therefore, we can reject the null hypothesis and conclude that there is a significant difference between the force required to open the noncycled standard circuit breakers exposed to a clean atmosphere and those exposed to Saigon sand.

.....

6. Comparison of the Force To Open Noncycled Standard Circuit Breakers Exposed to a Blowing Desert Sand Environment

CL		DE	
Specimen No.	Force To Open (lb)	Specimen No.	Force To Open (lb)
1	5.75	26	5.25
2	4.00	27	6.25
3	4.25	28	4.75
4	3.75	29	7.50
5	4.00	30	7.50
$T_1 = 21.75$		$T_2 = 31.25$	

$T.. = 53.00$

Observations: $N = 10$
 $K = 2$

Mean Force To Open

$CL \rightarrow 21.75/(5) = 4.35$

$DE \rightarrow 31.25/(5) = 6.25$

Source	d.f.	SS	MS	F ratio (Cat ÷ Err)
Catalyst	1	9.02	9.02	F cal = 8.05
Error	8	8.96	1.12	
Total	9	17.98		

$$\begin{aligned}
SST &= (5.75)^2 + (4.00)^2 + \dots + (7.50)^2 - T_{..}^2/10 \\
SST &= 298.88 - 280.90 \\
SST &= 17.98 \\
SSCAT &= (21.75)^2/(5) + (31.25)^2/(5) - T_{..}^2/10 \\
SSCAT &= 94.61 + 195.31 - 280.90 \\
SSCAT &= 9.02 \\
SSERR &= SST - SSCAT \\
SSERR &= 8.96 \\
F_{1, 8; .95} &= 5.32 < F_{cal} = 8.05
\end{aligned}$$

Therefore, we can reject the null hypothesis and conclude that there is a significant difference between the force required to open the noncycled standard circuit breakers exposed to a clean atmosphere and those exposed to desert sand.

.....

7. Comparison of the Force To Open Noncycled Standard Circuit Breakers Exposed to a Blowing 140-Mesh Silica Flour Sand Environment

CL		SIL	
Specimen No.	Force To Open (lb)	Specimen No.	Force To Open (lb)
1	5.75	31	9.50
2	4.00	32	6.75
3	4.25	33	10.00
4	3.75	34	6.50
5	4.00	35	10.00
	$T_1 = 21.75$		$T_2 = 42.75$

$T_{..} = 64.50$

Observations: N = 10
K = 2

Mean Force To Open

CL $\rightarrow 21.75/(5) = 4.35$

SIL $\rightarrow 42.75/(5) = 8.55$

Source	d.f.	SS	MS	F ratio (Cat \div Err)
Catalyst	1	44.09	44.09	F cal = 23.33
Error	8	15.13	1.89	
Total	9	59.22		

$$SST = (5.75)^2 + (4.00)^2 + \dots + (10.00)^2 - T..^2/10$$
$$SST = 475.25 - 416.03$$
$$SST = 59.22$$
$$SSCAT = (21.75)^2/(5) + (42.75)^2/(5) - T..^2/10$$
$$SSCAT = 94.61 + 365.51 - 416.03$$
$$SSCAT = 44.09$$
$$SSERR = SST - SSCAT$$
$$SSERR = 15.13$$
$$F_{1, 8; .95} = 5.32 < F_{cal} = 23.33$$

Therefore, we can reject the null hypothesis and conclude that there is a significant difference between the force required to open the noncycled standard circuit breakers exposed to a clean atmosphere and those exposed to 140-mesh silica flour sand.

.....

8. Goodness-of-Fit Test for a Normal Distribution of the Force To Open Standard Circuit Breakers Exposed to Sand

Assume: Continuous distribution
Chi-squared goodness-of-fit test
 $\alpha = 0.05$

Normal distribution

Sand- and dust-exposed noncycled samples only (specimens 6 through 35)

Interval (lb)	Frequency
4.00 - 5.00	4
5.01 - 6.00	6
6.01 - 7.00	7
7.01 - 8.00	2
8.01 - 9.00	5
9.01 - 10.00	5
10.01 - 20.00	1
	30

Interval (lb) (L _i - U _i)	Observed Frequency (O _i)	Expected Frequency (E _i)*	O _i - E _i	(O _i - E _i) ²	$\frac{(O_i - E_i)^2}{E_i}$
4.00 - 5.00	4	30 [P(x)] = 5	1	1	0.20
5.01 - 6.00	6	4	2	4	1.00
6.01 - 7.00	7	4	3	9	2.25
7.01 - 8.00	2	6	1	1	0.17
8.01 - 9.00	5				
9.01 - 10.00	5	4	2	4	1.00
10.01 - 20.00	1				
					4.62

*See equation below.

$$\mu = \frac{\sum x}{n} = \frac{179.75}{30} = \boxed{5.99 = \mu}$$

$$\sigma = \sqrt{\frac{N \sum x^2 - (\sum x)^2}{n^2}} = \sqrt{\frac{30(1933.45) - 50512.5}{900}}$$

$$\sigma = \sqrt{\frac{-491.0}{900}}$$

$$\boxed{\sigma = 2.89}$$

$$G(Z) = \int_Z^{\infty} \frac{1}{\sqrt{2\pi}} e^{-(t^2/2)} dt$$

where $Z = \frac{x - \mu}{\sigma} = \frac{x - 5.99}{2.89}$

$P(x) = P(4.00 < x < 5.00) = [1 - G(Z_{x_L} = 4.00)] - [1 - G(Z_{x_u} = 5.00)]$

$P(x) = P(9.01 < x < 20.00) = [G(Z_{x_L} = 9.01)] - [G(Z_{x_u} = 20.00)]$

Interval (x)						
L_i	U_i	Z_L	Z_u	GZ_L	GZ_u	$P(x)$
4.00	5.00	-0.689	-0.343	0.24541	0.36580	0.120
5.01	6.00	-0.339	0.003	0.36731	0.49880	0.134
6.01	7.00	0.007	0.349	0.49721	0.36355	0.134
7.01	9.00	0.353	1.04	0.36204	0.14917	0.213
9.01	20.00	1.05	4.85	0.14686	0.00002	0.147

$\chi^2 = 4.62$ (observed)

$\chi^2_{\alpha, K - W - 1} = \chi^2_{0.05, 5 - 2 - 1}$

where $K = 5$ (number of intervals)

$W = 2$ (number of parameters estimated, σ and μ)

$\chi^2_{0.05, 2} = 5.991$ (Table H-3, Reference 4)

Since $\sum_{i=1}^5 \frac{(O_i - E_i)^2}{E_i} = 4.62 < \chi^2_{0.05, 2} = 5.991$, there is not sufficient evidence to

reject the normal distribution as a model for these failure times.

.....

9. Comparison of Force To Open Noncycled Circuit Breakers of Different Sealing Methods Against a Blowing Saigon Sand Environment

STD Standard
 STD+ Standard Plus Dust Boot
 CS Completely Sealed

STD		STD+		CS	
Specimen No.	Force To Open (lb)	Specimen No.	Force To Open (lb)	Specimen No.	Force To Open (lb)
21	9.50	61	9.75	56	6.00
22	(Dropped)	62	6.00	57	7.50
23	8.50	63	5.25	58	7.75
24	6.50	64	6.75	59	7.75
25	6.00	65	5.00	60	4.25
$T_1 = 30.50$		$T_2 = 32.75$		$T_3 = 33.25$	

$$T.. = 96.50$$

Observations: N = 14
K = 3

Mean Force To Open

$$STD \rightarrow 30.50/(4) = 7.63$$

$$STD+ \rightarrow 32.75/(5) = 6.55$$

$$CS \rightarrow 33.25/(5) = 6.65$$

Source	d.f.	SS	MS	F ratio (Cat ÷ Err)
Catalyst	2	3.02	1.51	F cal = 0.517
Error	11	32.08	2.92	
Total	13	35.10		

$$SST = (9.50)^2 + (8.50)^2 + \dots + (4.25)^2 - T..^2/14$$

$$SST = 700.26 - 665.16$$

$$SST = 35.10$$

$$SSCAT = (30.50)^2/(4) + (32.75)^2/(5) + (33.25)^2/(5) - T..^2/14$$

$$SSCAT = 232.56 + 214.51 + 221.11 - 665.16$$

$$SSCAT = 3.02$$

$$SSERR = SST - SSCAT$$

$SSERR = 32.08$ $F_{2, 11; .95} = 3.98 > F_{cal} = 0.517$
--

Therefore, we can not reject the null hypothesis or conclude that the sealing methods affect the force to open noncycled circuit breakers when exposed to Saigon sand.

.....

10. Comparison of the Force To Open Noncycled Circuit Breakers of Different Sealing Methods Against a Blowing Desert Sand Environment

STD		STD+		CS	
Specimen No.	Force To Open (lb)	Specimen No.	Force To Open (lb)	Specimen No.	Force To Open (lb)
26	5.25	46	12.00	51	4.50
27	6.25	47	12.00	52	6.00
28	4.75	48	10.50	53	3.00
29	7.50	49	8.75	54	7.50
30	7.50	50	8.00	55	4.50
$T_1 = 31.25$		$T_2 = 51.25$		$T_3 = 25.50$	

$T_{..} = 108.0$

Observations: N = 15
K = 3

Mean Force To Open

STD → $31.25/(5) = 6.25$

STD+ → $51.25/(5) = 10.25$

CS → $25.50/(5) = 5.10$

Source	d.f.	SS	MS	F ratio (Cat ÷ Err)
Catalyst	2	73.07	36.54	F cal = 13.89
Error	12	31.58	2.63	
Total	14	104.65		

$$\begin{aligned}
SST &= (5.25)^2 + (6.25)^2 + \dots + (4.50)^2 - T..^2/15 \\
SST &= 882.25 - 777.60 \\
SST &= 104.65 \\
SSCAT &= (31.25)^2/(5) + (51.25)^2/(5) + (25.50)^2/(5) - T..^2/15 \\
SSCAT &= 195.31 + 525.31 + 130.05 - 777.60 \\
SSCAT &= 73.07 \\
SSERR &= SST - SSCAT \\
SSERR &= 31.58 \\
F_{2, 12; .95} &= 3.89 < F_{cal} = 13.89
\end{aligned}$$

Therefore, we can reject the null hypothesis and conclude that the sealing methods do affect the force to open these circuit breakers when exposed to desert sand.



11. Comparison of the Force To Open Noncycled Circuit Breakers of Different Sealing Methods Against a Blowing 140-Mesh Silica Flour Sand Environment (Figure 20)

STD		STD+		CS	
Specimen No.	Force To Open (lb)	Specimen No.	Force To Open (lb)	Specimen No.	Force To Open (lb)
31	9.50	41	5.50	36	4.00
32	6.75	42	5.00	37	4.50
33	10.00	43	2.50	38	5.00

Specimen No.	Force To Open (lb)	Specimen No.	Force To Open (lb)	Specimen No.	Force To Open (lb)
34	6.50	44	6.25	39	4.00
35	10.00	45	4.25	40	4.00
$T_1 = 42.75$		$T_2 = 23.50$		$T_3 = 21.50$	

$$T_{..} = 87.75$$

Observations: N = 15
K = 3

Mean Force To Open

$$STD \rightarrow 42.75/(5) = 8.55$$

$$STD+ \rightarrow 23.50/(5) = 4.70$$

$$CS \rightarrow 21.50/(5) = 4.30$$

Source	d.f.	SS	MS	F ratio (Cat ÷ Err)
Catalyst	2	55.07	27.54	F cal = 15.39
Error	12	21.53	1.79	
Total	14	76.60		

$$SST = (9.50)^2 + (6.75)^2 + \dots + (4.00)^2 - T_{..}^2/15$$

$$SST = 589.94 - 513.34$$

$$SST = 76.60$$

$$SSCAT = (42.75)^2/(5) + (23.50)^2/(5) + (21.50)^2/(5) - T_{..}^2/15$$

$$SSCAT = 365.51 + 110.45 + 92.45 - 513.34$$

$$SSCAT = 55.07$$

$$SSERR = SST - SSCAT$$

$$SSERR = 21.53$$

$$F_{2, 12; .95} = 3.89 < F_{cal} = 15.39$$

Therefore, we can reject the null hypothesis and conclude that there is a significant difference between the sealing methods' effects on the force to open these circuit breakers when exposed to 140-mesh silica flour sand.

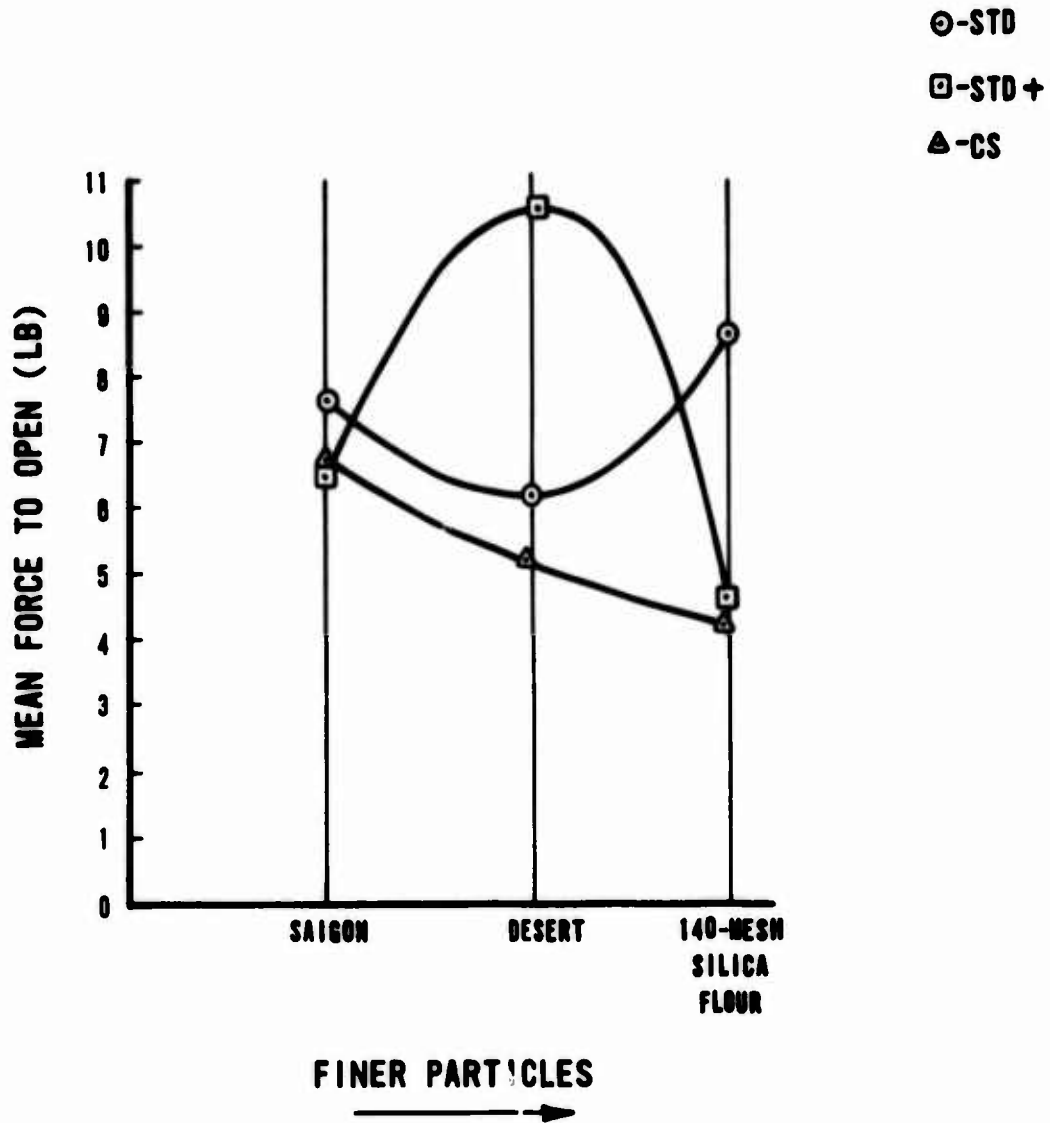

Figure 20. Mean Force To Open Versus Sand Samples.

There do not appear to be any definite trends that can be established from the plot in Figure 20.

.....

12. Comparison of the Force To Open Noncycled Standard Circuit Breakers Exposed to Blowing Saigon, Desert, and 140-Mesh Silica Flour Sand

S		DE		SIL	
Specimen No.	Force To Open (lb)	Specimen No.	Force To Open (lb)	Specimen No.	Force To Open (lb)
21	9.50	26	5.25	31	9.50
22	(Dropped)	27	6.25	32	6.75
23	8.50	28	4.75	33	10.00
24	6.50	29	7.50	34	6.50
25	6.00	30	7.50	35	10.00
$T_1 = 30.50$		$T_2 = 31.25$		$T_3 = 42.75$	

$T.. = 104.50$

Observations: N = 14
K = 3

Mean Force To Open

S → $30.50/(4) = 7.63$

DE → $31.25/(5) = 6.25$

SIL → $42.75/(5) = 8.55$

Source	d.f.	SS	MS	Fratio (Cat ÷ Err)
Catalyst	2	13.36	6.68	F cal = 2.70
Error	11	27.12	2.47	
Total	13	40.48		

$$SST = (9.50)^2 + (8.50)^2 + \dots + (10.00)^2 - T..^2/14$$

$$SST = 820.50 - 780.02$$

$$SST = 40.48$$

$$SSCAT = (30.50)^2/(4) + (31.25)^2/(5) + (42.75)^2/(5) - T..^2/14$$

$$SSCAT = 232.56 + 195.31 + 365.51 - 780.02$$

$SSCAT = 13.36$ $SSERR = SST - SSCAT$ $SSERR = 27.12$ $F_{2, 11; .95} = 3.98 > F_{cal} = 2.70$

Therefore, we can not reject the null hypothesis or conclude that these sand samples affect the force to open standard circuit breakers.



13. Comparison of the Force To Open Noncycled Standard Circuit Breakers With a Dust Boot Exposed to Blowing Saigon, Desert, and 140-Mesh Silica Flour Sand

S		DE		SIL	
Specimen No.	Force To Open (lb)	Specimen No.	Force To Open (lb)	Specimen No.	Force To Open (lb)
61	9.75	46	12.00	41	5.50
62	6.00	47	12.00	42	5.00
63	5.25	48	10.50	43	2.50
64	6.75	49	8.75	44	6.25
65	5.00	50	8.00	45	4.25
$T_1 = 32.75$		$T_2 = 51.25$		$T_3 = 23.50$	

$T_{..} = 107.50$

Observations: N = 15
K = 3

Mean Force To Open

S → $32.75/(5) = 6.55$

DE → $51.25/(5) = 10.25$

SIL → $23.50/(5) = 4.70$

Source	d.f.	SS	MS	F ratio (Cat ÷ Err)
Catalyst	2	79.85	39.93	F cal = 13.18
Error	12	36.36	3.03	
Total	14	116.21		

$$\begin{aligned}
SST &= (9.75)^2 + (6.00)^2 + \dots + (4.25)^2 - T..^2/15 \\
SST &= 886.63 - 770.42 \\
SST &= 116.21 \\
SSCAT &= (32.75)^2/(5) + (51.25)^2/(5) + (23.50)^2/(5) - T..^2/15 \\
SSCAT &= 214.51 + 525.31 + 110.45 - 770.42 \\
SSCAT &= 79.85 \\
SSERR &= SST - SSCAT \\
SSERR &= 36.36 \\
F_{2, 12; .95} &= 3.89 < F_{cal} = 13.18
\end{aligned}$$

Therefore, we can reject the null hypothesis and conclude that there is a significant difference between the effects caused by these sand samples on the force to open standard circuit breakers with a dust boot.



14. Comparison of the Force To Open Noncycled Completely Sealed Circuit Breakers Exposed to Blowing Saigon, Desert, and 140-Mesh Silica Flour Sand

S		DE		SIL	
Specimen No.	Force To Open (lb)	Specimen No.	Force To Open (lb)	Specimen No.	Force To Open (lb)
56	6.00	51	4.50	36	4.00
57	7.50	52	6.00	37	4.50
58	7.75	53	3.00	38	5.00

Specimen No.	Force To Open (lb)	Specimen No.	Force To Open (lb)	Specimen No.	Force To Open (lb)
59	7.75	54	7.50	39	4.00
60	4.25	55	4.50	40	4.00
$T_1 = 33.25$		$T_2 = 25.50$		$T_3 = 21.50$	

$$T_{..} = 80.25$$

Observations: N = 15
K = 3

Mean Force To Open

$$S \rightarrow 33.25/(5) = 6.65$$

$$DE \rightarrow 25.50/(5) = 5.10$$

$$SIL \rightarrow 21.50/(5) = 4.30$$

Source	d.f.	SS	MS	F ratio (Cat ÷ Err)
Catalyst	2	14.27	7.14	F cal = 3.92
Error	12	21.83	1.82	
Total	14	36.10		

$$SST = (6.00)^2 + (7.50)^2 + \dots + (4.00)^2 - T_{..}^2/15$$

$$SST = 465.44 - 429.34$$

$$SST = 36.10$$

$$SSCAT = (33.25)^2/(5) + (25.50)^2/(5) + (21.50)^2/(5) - T_{..}^2/15$$

$$SSCAT = 221.11 + 130.05 + 92.45 - 429.34$$

$$SSCAT = 14.27$$

$$SSERR = SST - SSCAT$$

$$SSERR = 21.83$$

$$F_{2, 12; .95} = 3.89 < F_{cal} = 3.92$$

Therefore, we can reject the null hypothesis and conclude that Saigon, desert, and 140-mesh silica flour sand cause a significant difference in the force to open completely sealed circuit breakers.

APPENDIX V
ANALYSIS OF THE EFFECT OF SAND
ON THE FORCE TO CLOSE PLUNGER-TYPE CIRCUIT BREAKERS

This appendix contains the one-way classification analysis of variance for the effect of various blowing sand samples on the force to close plunger-type circuit breakers.

1. Comparison of the Force To Close Noncycled Standard Circuit Breakers Exposed to Blowing Sand

VA		DA		FB	
Specimen No.	Force To Close (lb)	Specimen No.	Force To Close (lb)	Specimen No.	Force To Close (lb)
6	6.50	11	7.50	16	7.50
7	6.00	12	6.75	17	6.75
8	7.50	13	8.50	18	6.50
9	9.00	14	6.50	19	7.25
10	7.25	15	7.25	20	8.25
$T_1 = 36.25$		$T_2 = 36.50$		$T_3 = 36.25$	

S		DE		SIL	
Specimen No.	Force To Close (lb)	Specimen No.	Force To Close (lb)	Specimen No.	Force To Close (lb)
21	6.75	26	6.75	31	7.50
22	8.25	27	6.00	32	7.50
23	7.50	28	5.75	33	7.25
24	8.75	29	6.25	34	7.75
25	7.25	30	6.00	35	6.75
$T_4 = 38.50$		$T_5 = 30.75$		$T_6 = 36.75$	

$T_{..} = 215.00$

Observations: $N = 30$
 $K = 6$

Mean Force To Close

VA → 36.25/(5) = 7.25

DA → 36.50/(5) = 7.30

FB → 36.25/(5) = 7.25

S → 38.50/(5) = 7.70

DE → 30.75/(5) = 6.15

SIL → 36.75/(5) = 7.35

Source	d.f.	SS	MS	Fratio (Cat ÷ Err)
Catalyst	5	6.92	1.38	F cal = 2.51
Error	24	13.24	0.55	
Total	29	20.16		

$$\begin{aligned}
 SST &= (6.50)^2 + (6.00)^2 + \dots + (6.75)^2 - T..^2/30 \\
 SST &= 1560.99 - 1540.83 \\
 SST &= 20.16 \\
 SSCAT &= (36.25)^2/(5) + (36.50)^2/(5) + \dots + (36.75)^2/(5) - T..^2/30 \\
 SSCAT &= 1547.75 - 1540.83 \\
 SSCAT &= 6.92 \\
 SSERR &= SST - SSCAT \\
 SSERR &= 13.24 \\
 F_{5, 24; .95} &= 2.62 > F_{cal} = 2.51
 \end{aligned}$$

Therefore, we can not reject the null hypothesis or conclude that there is a significant difference between the sand samples' effects on the force to close noncycled standard circuit breakers following exposure to blowing sand.



2. Comparison of Force To Close Noncycled Standard Circuit Breakers Exposed to a Blowing Virginia Beach Sand Environment

CL		VA	
Specimen No.	Force To Close (lb)	Specimen No.	Force To Close (lb)
1	6.00	6	6.50
2	6.50	7	6.00
3	6.25	8	7.50
4	6.00	9	9.00
5	7.50	10	7.25
$T_1 = 32.25$		$T_2 = 36.25$	

$T_{..} = 68.50$

Observations: $N = 10$
 $K = 2$

Mean Force To Close

$CL \rightarrow 32.25/(5) = 6.45$

$VA \rightarrow 36.25/(5) = 7.25$

Source	d.f.	SS	MS	F ratio (Cat ÷ Err)
Catalyst	1	1.59	1.59	$F_{cal} = 1.87$
Error	8	6.80	0.85	
Total	9	8.39		

$$SST = (6.00)^2 + (6.50)^2 + \dots + (7.25)^2 - T_{..}^2/10$$

$$SST = 477.62 - 469.23$$

$$SST = 8.39$$

$$SSCAT = (32.25)^2/(5) + (36.25)^2/(5) - T_{..}^2/10$$

$$SSCAT = 208.01 + 262.81 - 469.23$$

$$SSCAT = 1.59$$

$$\begin{aligned}
 SSERR &= SST - SSCAT \\
 SSERR &= 6.80 \\
 F_{1, 8; .95} &= 5.32 > F_{cal} = 1.87
 \end{aligned}$$

Therefore, we can not reject the null hypothesis or conclude a significant influence.



3. Comparison of the Force To Close Noncycled Standard Circuit Breakers Exposed to a Blowing Da Nang Sand Environment

CL		DA	
Specimen No.	Force To Close (lb)	Specimen No.	Force To Close (lb)
1	6.00	11	7.50
2	6.50	12	6.75
3	6.25	13	8.50
4	6.00	14	6.50
5	7.50	15	7.25
$T_1 = 32.25$		$T_2 = 36.50$	

$T_{..} = 68.75$

Observations: N = 10
K = 2

Mean Force To Close

CL → $32.25/(5) = 6.45$

DA → $36.50/(5) = 7.30$

Source	d.f.	SS	MS	F ratio (Cat ÷ Err)
Catalyst	1	1.80	1.80	F _{cal} = 3.60
Error	8	3.98	0.50	
Total	9	5.78		

$$\begin{aligned}
SST &= (6.00)^2 + (6.50)^2 + \dots + (7.25)^2 - T_{..}^2/10 \\
SST &= 478.44 - 472.66 \\
SST &= 5.78 \\
SSCAT &= (32.25)^2/(5) + (36.50)^2/(5) - T_{..}^2/10 \\
SSCAT &= 208.01 + 266.45 - 472.66 \\
SSCAT &= 1.80 \\
SSERR &= SST - SSCAT \\
SSERR &= 3.98 \\
F_{1, 8; .95} &= 5.32 > F_{cal} = 3.60
\end{aligned}$$

Therefore, we can not reject the null hypothesis or conclude a significant influence.



4. Comparison of the Force To Close Noncycled Standard Circuit Breakers Exposed to a Blowing Fort Benning Sand Environment

CL		FB	
Specimen No.	Force To Close (lb)	Specimen No.	Force To Close (lb)
1	6.00	16	7.50
2	6.50	17	6.75
3	6.25	18	6.50
4	6.00	19	7.25
5	7.50	20	8.25
	$T_1 = 32.25$		$T_2 = 36.25$

$T_{..} = 68.50$

Observations: N = 10
K = 2

Mean Force To Close

CL $\rightarrow 32.25/(5) = 6.45$

FB $\rightarrow 36.25/(5) = 7.25$

Source	d.f.	SS	MS	F ratio (Cat \div Err)
Catalyst	1	1.59	1.59	
Error	8	3.43	0.43	F cal = 3.71
Total	9	5.02		

$$SST = (6.00)^2 + (6.50)^2 + \dots + (8.25)^2 - T..^2/10$$
$$SST = 474.25 - 469.23$$
$$SST = 5.02$$
$$SSCAT = (32.25)^2/(5) + (36.25)^2/(5) - T..^2/10$$
$$SSCAT = 208.01 + 262.81 - 469.23$$
$$SSCAT = 1.59$$
$$SSERR = SST - SSCAT$$
$$SSERR = 3.43$$
$$F_{1, 8; .95} = 5.32 > F_{cal} = 3.71$$

Therefore, we can not reject the null hypothesis or conclude a significant influence.



5. Comparison of the Force To Close Noncycled Standard Circuit Breakers Exposed to a Blowing Saigon Sand Environment

CL		S	
Specimen No.	Force To Close (lb)	Specimen No.	Force To Close (lb)
1	6.00	21	6.75
2	6.50	22	8.25
3	6.25	23	7.50
4	6.00	24	8.75
5	7.50	25	7.25
$T_1 = 32.25$		$T_2 = 38.50$	

$T_{..} = 70.75$

Observations: $N = 10$
 $K = 2$

Mean Force To Close

$CL \rightarrow 32.25/(5) = 6.45$

$S \rightarrow 38.50/(5) = 7.70$

Source	d.f.	SS	MS	F ratio (Cat ÷ Err)
Catalyst	1	3.90	3.90	$F_{cal} = 7.65$
Error	8	4.10	0.51	
Total	9	8.00		

$SST = (6.00)^2 + (6.50)^2 + \dots + (7.25)^2 - T_{..}^2/10$
 $SST = 508.56 - 500.56$
 $SST = 8.00$
 $SSCAT = (32.25)^2/(5) + (38.50)^2/(5) - T_{..}^2/10$
 $SSCAT = 208.01 + 296.45 - 500.56$
 $SSCAT = 3.90$

Source	d.f.	SS	MS	F ratio (Cat ÷ Err)
Catalyst	1	0.22	0.22	F cal = 0.81
Error	8	2.13	0.27	
Total	9	2.35		

$$\begin{aligned}
SST &= (6.00)^2 + (6.50)^2 + \dots + (6.00)^2 - T..^2/10 \\
SST &= 399.25 - 396.90 \\
SST &= 2.35 \\
SSCAT &= (32.25)^2/(5) + (30.75)^2/(5) - T..^2/10 \\
SSCAT &= 208.01 + 189.11 - 396.90 \\
SSCAT &= 0.22 \\
SSERR &= SST - SSCAT \\
SSERR &= 2.13 \\
F_{1, 8; .95} &= 5.32 > F_{cal} = 0.81
\end{aligned}$$

Therefore, we can not reject the null hypothesis or conclude a significant influence.



7. Comparison of the Force To Close Noncycled Standard Circuit Breakers Exposed to a Blowing 140-Mesh Silica Flour Sand Environment

CL		SIL	
Specimen No.	Force To Close (lb)	Specimen No.	Force To Close (lb)
1	6.00	31	7.50
2	6.50	32	7.50
3	6.25	33	7.25

Specimen No.	Force To Close (lb)	Specimen No.	Force To Close (lb)
4	6.00	34	7.75
5	7.50	35	6.75
	$T_1 = 32.25$		$T_2 = 36.75$
$T.. = 69.00$			

Observations: N = 10
K = 2

Mean Force To Close

CL $\rightarrow 32.25/(5) = 6.45$

SIL $\rightarrow 36.75/(5) = 7.35$

Source	d.f.	SS	MS	F ratio (Cat + Err)
Catalyst	1	2.02	2.02	
Error	<u>8</u>	<u>2.13</u>	0.27	F cal = 7.48
Total	9	4.15		

$$SST = (6.00)^2 + (6.50)^2 + \dots + (6.75)^2 - T..^2/10$$

$$SST = 480.25 - 476.10$$

$$SST = 4.15$$

$$SSCAT = (32.25)^2/(5) + (36.75)^2/(5) - T..^2/10$$

$$SSCAT = 208.01 + 270.11 - 476.10$$

$$SSCAT = 2.02$$

$$SSERR = SST - SSCAT$$

$$SSERR = 2.13$$

$$F_{1, 8; .95} = 5.32 < F_{cal} = 7.48$$

Therefore, we can reject the null hypothesis and conclude that 140-mesh silica flour sand does cause a significant difference in the force to close a noncycled standard circuit breaker.

.....

8. Comparison of the Sealing Methods of Noncycled Circuit Breakers Exposed to Blowing Saigon Sand, Using the Force To Close as the Judgement Basis

STD		STD+		CS	
Specimen No.	Force To Close (lb)	Specimen No.	Force To Close (lb)	Specimen No.	Force To Close (lb)
21	6.75	61	6.50	56	7.25
22	8.25	62	6.00	57	6.75
23	7.50	63	6.25	58	6.75
24	8.75	64	6.25	59	6.75
25	7.25	65	6.75	60	7.25
$T_1 = 38.50$		$T_2 = 31.75$		$T_3 = 34.75$	

$T.. = 105.00$

Observations: $N = 15$
 $K = 3$

Mean Force To Close

STD $\rightarrow 38.50/(5) = 7.70$

STD+ $\rightarrow 31.75/(5) = 6.35$

CS $\rightarrow 34.75/(5) = 6.95$

Source	d.f.	SS	MS	F ratio (Cat \div Err)
Catalyst	2	4.58	2.29	F cal = 8.48
Error	12	3.18	0.27	
Total	14	7.76		

$$\begin{aligned}
SST &= (6.75)^2 + (8.25)^2 + \dots + (7.25)^2 - T_{..}^2/15 \\
SST &= 742.76 - 735.00 \\
SST &= 7.76 \\
SSCAT &= (38.50)^2/(5) + (31.75)^2/(5) + (34.75)^2/(5) - T_{..}^2/15 \\
SSCAT &= 739.58 - 735.00 \\
SSCAT &= 4.58 \\
SSERR &= SST - SSCAT \\
SSERR &= 3.18 \\
F_{2, 12; .95} &= 3.89 < F_{cal} = 8.48
\end{aligned}$$

Therefore, we can reject the null hypothesis and conclude that there is a significant difference between sealing methods when exposed to Saigon sand and measuring the force to close the circuit breakers.



9. Comparison of the Sealing Methods of Noncycled Circuit Breakers Exposed to Blowing Desert Sand, Using the Force To Close as the Judgement Basis

STD		STD+		CS	
Specimen No.	Force To Close (lb)	Specimen No.	Force To Close (lb)	Specimen No.	Force To Close (lb)
26	6.75	46	6.00	51	6.00
27	6.00	47	5.50	52	6.00
28	5.75	48	5.25	53	6.00
29	6.25	49	9.00	54	6.50
30	6.00	50	6.25	55	6.25
$T_1 = 30.75$		$T_2 = 32.00$		$T_3 = 30.75$	

$T_{..} = 93.50$

Observations: N = 15
K = 3

Mean Force To Close

STD → 30.75/(5) = 6.15

STD+ → 32.00/(5) = 6.40

CS → 30.75/(5) = 6.15

Source	d.f.	SS	MS	F ratio (Cat ÷ Err)
Catalyst	2	0.20	0.10	F cal = 0.12
Error	12	9.85	0.82	
Total	14	10.05		

$$SST = (6.75)^2 + (6.00)^2 + \dots + (6.25)^2 - T..^2/15$$

$$SST = 592.87 - 582.82$$

$$SST = 10.05$$

$$SSCAT = (30.75)^2/(5) + (32.00)^2/(5) + (30.75)^2/(5) - T..^2/15$$

$$SSCAT = 189.11 + 204.80 + 189.11 - 582.82$$

$$SSCAT = 0.20$$

$$SSERR = SST - SSCAT$$

$$SSERR = 9.85$$

$$F_{2, 12; .95} = 3.89 > F_{cal} = 0.12$$

Therefore, we can not reject the null hypothesis or conclude that there is a significant difference in the forces to close the circuit breakers caused by the sealing methods when exposed to desert sand.



10. Comparison of the Sealing Methods of Noncycled Circuit Breakers Exposed to Blowing 140-Mesh Silica Flour Sand, Using the Force To Close as the Judgement Basis

STD		STD+		CS	
Specimen No.	Force To Close (lb)	Specimen No.	Force To Close (lb)	Specimen No.	Force To Close (lb)
31	7.50	41	5.50	36	6.00
32	7.50	42	7.50	37	6.25
33	7.25	43	5.75	38	7.50
34	7.75	44	5.50	39	6.50
35	6.75	45	6.00	40	6.00
$T_1 = 36.75$		$T_2 = 30.25$		$T_3 = 32.25$	

$$T.. = 99.25$$

Observations: N = 15
K = 3

Mean Force To Close

$$STD \rightarrow 36.75/(5) = 7.35$$

$$STD+ \rightarrow 30.25/(5) = 6.05$$

$$CS \rightarrow 32.25/(5) = 6.45$$

Source	d.f.	SS	MS	F ratio (Cat ÷ Err)
Catalyst	2	4.44	2.22	F cal = 5.41
Error	12	4.93	0.41	
Total	14	9.37		

$$SST = (7.50)^2 + (7.50)^2 + \dots + (6.00)^2 - T..^2/15$$

$$SST = 666.07 - 656.70$$

$$SST = 9.37$$

$$SSCAT = (36.75)^2/(5) + (30.25)^2/(5) + (32.25)^2/(5) - T..^2/15$$

$SSCAT = 661.14 - 656.70$ $SSCAT = 4.44$ $SSERR = SST - SSCAT$ $SSERR = 4.93$ $F_{2, 12; .95} = 3.89 < F_{cal} = 5.41$
--

Therefore, we can reject the null hypothesis and conclude that there is a significant difference between sealing methods when exposed to 140-mesh silica flour sand based on the measured force to close the circuit breakers. There do not appear to be any definite trends that can be established from the plot in Figure 21.

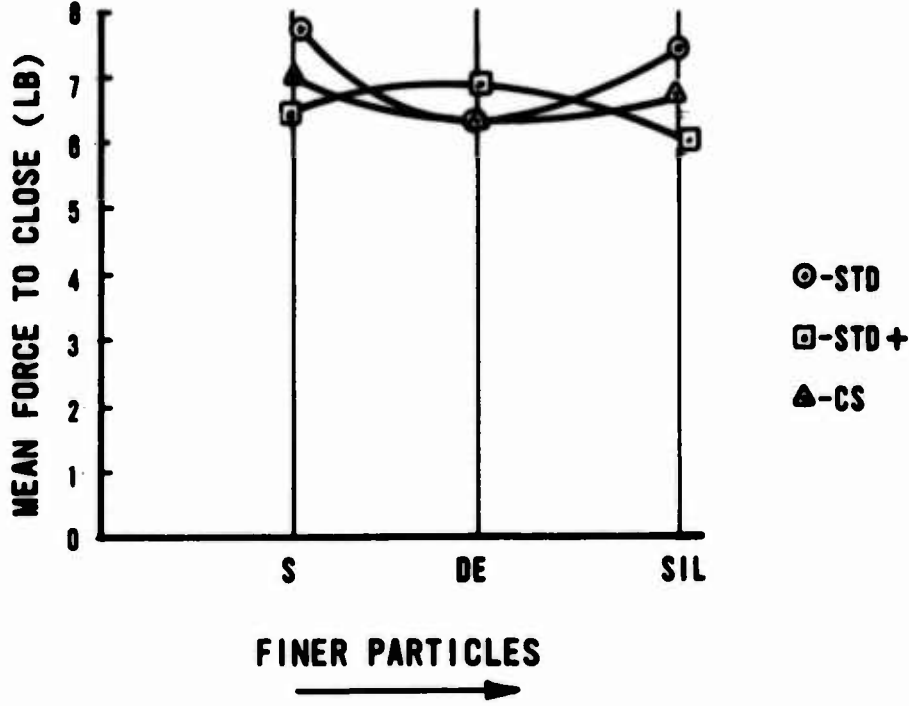

Figure 21. Mean Force To Close Versus Sand Samples.

.....

11. Comparison of Sand Samples' Effects on the Force To Close Noncycled Standard Circuit Breakers Following Exposure to Blowing Sand

S		DE		SIL	
Specimen No.	Force To Close (lb)	Specimen No.	Force To Close (lb)	Specimen No.	Force To Close (lb)
21	6.75	26	6.75	31	7.50
22	8.25	27	6.00	32	7.50
23	7.50	28	5.75	33	7.25
24	8.75	29	6.25	34	7.75
25	7.25	30	6.00	35	6.75
$T_1 = 38.50$		$T_2 = 30.75$		$T_3 = 36.75$	

$T_{..} = 106.00$

Observations: N = 15
K = 3

Mean Force To Close

S → $38.50/(5) = 7.70$

DE → $30.75/(5) = 6.15$

SIL → $36.75/(5) = 7.35$

Source	d.f.	SS	MS	F ratio (Cat + Err)
Catalyst	2	6.60	3.30	F cal = 10.65
Error	12	3.71	0.31	
Total	14	10.31		

$$SST = (6.75)^2 + (8.25)^2 + \dots + (6.75)^2 - T_{..}^2/15$$

$$SST = 759.38 - 749.07$$

$$SST = 10.31$$

$$SSCAT = (38.50)^2/(5) + (30.75)^2/(5) + (36.75)^2/(5) - T_{..}^2/15$$

$$SSCAT = 296.45 + 189.11 + 270.11 - 749.07$$

Source	d.f.	SS	MS	F ratio (Cat + Err)
Catalyst	2	0.35	0.18	F cal = 0.18
Error	12	12.21	1.02	
Total	14	12.56		

$$SST = (6.50)^2 + (6.00)^2 + \dots + (6.00)^2 - T..^2/15$$

$$SST = 601.63 - 589.07$$

$$SST = 12.56$$

$$SSCAT = (31.75)^2/(5) + (32.00)^2/(5) + (30.25)^2/(5) - T..^2/15$$

$$SSCAT = 201.61 + 204.80 + 183.01 - 589.07$$

$$SSCAT = 0.35$$

$$SSERR = SST - SSCAT$$

$$SSERR = 12.21$$

$$F_{2, 12; .95} = 3.89 > F_{cal} = 0.18$$

Therefore, we can not reject the null hypothesis or conclude that there is any significant difference between the effects on the force to close noncycled dust-boot-protected circuit breakers caused by Saigon, desert, and 140-mesh silica flour sand.

.....

13. Comparison of Sand Samples' Effects on the Force To Close Noncycled Completely Sealed Circuit Breakers Following Exposure to Blowing Sand

S		DE		SIL	
Specimen No.	Force To Close (lb)	Specimen No.	Force To Close (lb)	Specimen No.	Force To Close (lb)
56	7.25	51	6.00	36	6.00
57	6.25	52	6.00	37	6.25

Specimen No.	Force To Close (lb)	Specimen No.	Force To Close (lb)	Specimen No.	Force To Close (lb)
58	6.75	53	6.00	38	7.50
59	6.75	54	6.50	39	6.50
60	7.25	55	6.25	40	6.00
$T_1 = 34.25$		$T_2 = 30.75$		$T_3 = 25.75$	

$$T.. = 90.75$$

Observations: N = 15
K = 3

Mean Force To Close

$$S \rightarrow 34.25/(5) = 6.85$$

$$DE \rightarrow 30.75/(5) = 6.15$$

$$SIL \rightarrow 25.75/(5) = 5.15$$

Source	d.f.	SS	MS	F ratio (Cat ÷ Err)
Catalyst	2	7.29	3.64	F cal = 1.04
Error	12	41.86	3.49	
Total	14	49.15		

$$SST = (7.25)^2 + (6.25)^2 + \dots + (6.00)^2 - T..^2/15$$

$$SST = 598.19 - 549.04$$

$$SST = 49.15$$

$$SSCAT = (34.25)^2/(5) + (30.75)^2/(5) + (25.75)^2/(5) - T..^2/15$$

$$SSCAT = 234.61 + 189.11 + 132.61 - 549.04$$

$$SSCAT = 7.29$$

$$SSERR = SST - SSCAT$$

$$SSERR = 41.86$$

$$F_{2, 12; .95} = 3.89 > F_{cal} = 1.04$$

Therefore, we can not reject the null hypothesis or conclude that there is a significant influence by Saigon, desert, and 140-silica mesh flour sand on the force to close completely sealed circuit breakers.



14. Kolmogorov-Smirnov Goodness-of-Fit Test for a Normal Distribution of the Force To Close Standard Circuit Breakers Exposed to Sand

Assume: Normal Distribution; $\alpha = 0.05$

<u>Specimen Number</u>	<u>Force To Close (lb)</u>
6	6.50
7	6.00
8	7.50
9	9.00
10	7.25
11	7.50
12	6.75
13	8.50
14	6.50
15	7.25
16	7.50
17	6.75
18	6.50
19	7.25
20	8.25
21	6.75
22	8.25
23	7.50
24	8.75
25	7.25
26	6.75
27	6.00
28	5.75
29	6.25
30	6.00
31	7.50
32	7.50
33	7.25
34	7.75
35	6.75
Total	215.00

$$\bar{X} = 7.167$$

$$s^2 = \frac{\Sigma(X - \bar{X})^2}{n - 1} = \frac{\Sigma(X - 7.167)^2}{29} = \frac{20.17}{29}$$

$$s^2 = 0.696$$

$$s = 0.834$$

X	$\frac{X - \bar{X}}{s}$	F(X)	$\hat{F}(X)$	$ F(X) - \hat{F}(X) $
5.75	-1.699	0.047	0.033	0.014
6.00	-1.399	0.081	0.066	0.015
6.00	-1.399	0.081	0.099	0.018
6.00	-1.399	0.081	0.133	0.052
6.25	-1.100	0.136	0.167	0.031
6.50	-0.800	0.212	0.200	0.012
6.50	-0.800	0.212	0.233	0.021
6.50	-0.800	0.212	0.267	0.055
6.75	-0.500	0.309	0.300	0.009
6.75	-0.500	0.309	0.333	0.024
6.75	-0.500	0.309	0.367	0.058
6.75	-0.500	0.309	0.400	0.091
6.75	-0.500	0.309	0.433	0.124
7.25	0.100	0.540	0.467	0.073
7.25	0.100	0.540	0.500	0.040
7.25	0.100	0.540	0.533	0.007
7.25	0.100	0.540	0.567	0.027
7.25	0.100	0.540	0.600	0.060
7.50	0.399	0.655	0.633	0.022
7.50	0.399	0.655	0.667	0.012
7.50	0.399	0.655	0.700	0.045
7.50	0.399	0.655	0.733	0.078
7.50	0.399	0.655	0.767	0.122
7.50	0.399	0.655	0.800	0.145 Max.
7.75	0.699	0.758	0.833	0.075
8.25	1.299	0.904	0.867	0.037
8.25	1.299	0.904	0.900	0.004
8.50	1.598	0.946	0.933	0.013
8.75	1.898	0.972	0.967	0.005
9.00	2.198	0.986	1.000	0.014

$$F(X) = 1 - P \left(Z > \frac{X - \bar{X}}{S} \right)$$

$$d = \text{maximum absolute difference} = 0.145$$

$$d_{0.05} = 0.240 \text{ (Table H-6, Reference 4)}$$

$$d_{\text{max.}} = 0.145 < d_{0.05} = 0.240$$

Therefore, there is no reason to reject the assumption of normality with $\mu = 7.167$ pounds and $\sigma = 0.834$ pound.