

AD-773 064

IMPROVED TRANSITION RAMPS FOR
McMURDO STATION, ANTARCTICA

F. W. Brier

Naval Civil Engineering Laboratory
Port Hueneme, California

November 1973

DISTRIBUTED BY:

NTIS

National Technical Information Service
U. S. DEPARTMENT OF COMMERCE
5285 Port Royal Road, Springfield Va. 22151

AD 773064

Technical Note N-1317

IMPROVED TRANSITION RAMPS FOR MCMURDO STATION, ANTARCTICA

By

F. W. Brier

November 1973

Sponsored by
Naval Support Force, Antarctica

Approved for public release; distribution unlimited.

NAVAL CIVIL ENGINEERING LABORATORY
Port Hueneme, California 93043

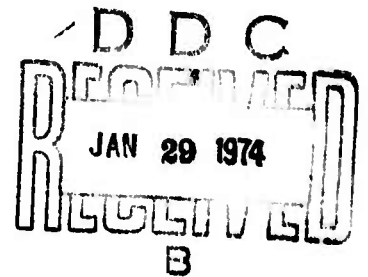

Reproduced by
NATIONAL TECHNICAL
INFORMATION SERVICE
U S Department of Commerce
Springfield VA 22151

IMPROVED TRANSITION RAMPS FOR MCMURDO STATION, ANTARCTICA

Technical Note N-1317

61-017

by

F. W. Brier

ABSTRACT

Wheeled vehicle travel between McMurdo Station and Williams Field is via a processed snow road on the Ross Ice Shelf or on an annual sea ice road across McMurdo Sound. The critical areas of construction and maintenance on the McMurdo road system are at points of transition from one road material to another material. Three transition conditions exist in the road system: annual sea ice to snow, snow to land, and annual sea ice to land. Each of the three transition zones has different construction and maintenance problems. These problems were reviewed and field tests were conducted on various types of surfacing materials at Port Hueneme, California, and McMurdo Station, Antarctica. The field tests showed AM₂ aluminum planking was more durable than Mo-mat, but Mo-mat has sufficient strength to support vehicular traffic when it is properly anchored. The field tests also indicated that when placed on sea ice AM₂ aluminum planking and Mo-mat must be insulated to prevent surface melting of the ice.

ACCESSION NO. _____

DATE SECTION _____

UNCLASSIFIED DATE SECTION _____

JUSTIFICATION _____

BY _____

DISTRIBUTION AVAILABILITY CODES _____

DISTRIBUTION _____ AVAIL. AND/OR SPECIAL _____

D

Approved for public release; distribution unlimited.

Copies available at the National Technical Information Service (NTIS),
Sills Building, 5285 Port Royal Road, Springfield, Va. 22151

Unclassified

Security Classification

DOCUMENT CONTROL DATA - R & D		
<i>(Security classification of title, body of abstract and indexing annotation must be entered when the overall report is classified)</i>		
1. ORIGINATING ACTIVITY (Corporate author) Naval Civil Engineering Laboratory Port Hueneme, California 93043		2a. REPORT SECURITY CLASSIFICATION Unclassified
		2b. GROUP
3. REPORT TITLE IMPROVED TRANSITION RAMPS FOR MCMURDO STATION, ANTARCTICA		
4. DESCRIPTIVE NOTES (Type of report and inclusive dates) Final; July 1972 - June 1973		
5. AUTHOR(S) (First name, middle initial, last name) F. W. Brier		
6. REPORT DATE November 1973	7a. TOTAL NO. OF PAGES 21 29	7b. NO. OF REFS 0
8a. CONTRACT OR GRANT NO.	8b. ORIGINATOR'S REPORT NUMBER(S) TN-1317	
8c. PROJECT NO 61-017		
c.	9b. OTHER REPORT NO(S) (Any other numbers that may be assigned this report)	
d.		
10. DISTRIBUTION STATEMENT Approved for public release; distribution unlimited.		
11. SUPPLEMENTARY NOTES	12. SPONSORING MILITARY ACTIVITY Naval Support Forces, Antarctica FPO New York, New York 09501	
13. ABSTRACT <p>Wheeled vehicle travel between McMurdo Station and Williams Field is via a processed snow road on the Ross Ice Shelf or on an annual sea ice road across McMurdo Sound. The critical areas of construction and maintenance on the McMurdo road system are at points of transition from one road material to another material. Three transition conditions exist in the road system: annual sea ice to snow, snow to land, and annual sea ice to land. Each of the three transition zones has different construction and maintenance problems. These problems were reviewed and field tests were conducted on various types of surfacing materials at Port Hueneme, California, and McMurdo Station, Antarctica. The field tests showed AM₂ aluminum planking was more durable than Mo-mat, but Mo-mat has sufficient strength to support vehicular traffic when it is properly anchored. The field tests also indicated that when placed on sea ice AM₂ aluminum planking and Mo-mat must be insulated to prevent surface melting of the ice.</p>		

Unclassified

Security Classification

14 KEY WORDS	LINK A		LINK B		LINK C	
	ROLE	WT	ROLE	WT	ROLE	WT
Transition ramps						
Snow roads						
Sea ice roads						
Surfacing materials						
Insulations						
Aluminum planking						
Construction						
Maintenance						
Ross Ice Shelf						
McMurdo Sound						
Wheeled vehicles						
Polar regions						

INTRODUCTION

McMurdo Station is the logistics center for all United States air operations in Antarctica. The station is located on Ross Island near the tip of Hut Point Peninsula. Aircraft landing and support facilities for McMurdo Station are located at Williams Field which is about five miles away on the Ross Ice Shelf (Figure 1). Wheeled vehicle travel between McMurdo Station and Williams Field was initiated in 1965. Prior to 1965, tracked vehicles were used exclusively for over-snow transport at McMurdo Station. For an efficient air logistics operation using wheeled vehicles for over-snow transport, it is essential that a road system be maintained between McMurdo Station and Williams Field. Travel between McMurdo Station and Williams Field is via a processed snow road on the Ross Ice Shelf or on an annual sea ice road across McMurdo Sound (Figure 1).

The critical areas of construction and maintenance on the McMurdo road system are at points of transition from one road material to another material. Three transition conditions exist in the road system: annual sea ice to snow, snow to land, and annual sea ice to land.

The transition from sea ice to snow occurs where the Ross Ice Shelf and annual sea ice in McMurdo Sound adjoin. The transition from snow to land occurs near Scott Base where the Ross Ice Shelf abuts Ross Island. Since Deep Freeze 69 (DF-69), the transition from sea ice to land has been at VXE-6 Hill. Prior to DF-69, the transition from sea ice to land occurred on the shoreline between Observation Hill and Scott Base on what was called the Pass Road.

Each of the three transition zones has different construction and maintenance problems. The major problems at the sea ice to snow transition are snowdrift accumulation, high gradient, and downwarping of the sea ice. If downwarping occurs, salt water pools form on the surface of the sea ice causing deterioration of the roadway. At the transitions from snow to land and sea ice to land, the major problem is deterioration of the roadway surface by melting. At these transitions, dirt is tracked by vehicles from land onto snow or sea ice roadway, where it absorbs solar radiation. During the summer, high solar radiation and near-or-above thawing temperatures decrease the wear resistance of the snow or sea ice surface; the ice surface becomes rough and granular, and the compacted snow road becomes soft and mushy. Working tide cracks between the floating sea ice and Ross Island present additional problems at the sea ice to land transition. Vehicular traffic over tide cracks causes the shoulders of the crack to collapse. Eventually, holes 2- to 3-feet wide and a foot or more deep develop at the tide crack impeding vehicular traffic.

To improve trafficability and reduce maintenance cost of the McMurdo Road system, techniques and surfacing materials are needed to minimize deterioration of the three transition zones. This technical note covers field tests on surfacing materials

conducted at Port Hueneme, California, during August 1972, and at McMurdo Station, Antarctica, during the austral summer 1972-1973. Construction and maintenance techniques at the three transition zones are also discussed in this technical note.

BACKGROUND

Since the introduction of wheeled vehicles to Operation Deep Freeze in 1965, travel between McMurdo Station and Williams Field has been hindered by adverse conditions at locations of transition from annual sea ice to land, snow to land, and annual sea ice to snow. Each of the three transition zones has different construction and maintenance problems. Weather conditions, amount of vehicle traffic, and maintenance techniques influence the intensity of the problems at each transition zone. Since these factors vary from year to year, the intensity of the problems also changes.

Early attempts at improving the trafficability of transition zones consisted of compacted snow roadways or ramps (Figure 2). This technique was satisfactory at the transition from sea ice to snow, but was unsatisfactory at transitions to land. Large quantities of snow are sometimes difficult to obtain near the transitions from sea ice or land, and dirt near the transitions to land caused rapid deterioration of the snow ramps.

During DF-68, the Naval Civil Engineering Laboratory (NCEL) fabricated and installed a 32-foot long timber ramp (Figure 3) over the tide crack at the transition from sea ice to land on the Pass Road between McMurdo Station and Williams Field (Figure 1). The ramp was fabricated with 16-foot long, 6x6 stringers covered with 2x6 decking. The experimental timber ramp, which was tested under NCEL Work Unit YF 53.536.001.01.002, "Vehicle Road Systems on Snow and Ice," improved trafficability, but only slightly. The major shortcoming of the experimental ramp was its limited length. It was also time consuming to construct and required frequent repair.

In DF-69, the Antarctic Support Activities, which is now called the Naval Support Force, Antarctica (NSFA), constructed several timber ramp sections with a total length of about 100 feet and placed them at the VXE-6 Hill sea ice to land transition. The construction of the ramp sections was similar to the DF-68 experimental ramp but larger timbers were used for all members. The ramp improved trafficability over the tide crack area but was insufficient in length to eliminate problems of surface melting. Surface deterioration of the sea ice up to 500 feet from the shoreline hindered and sometimes stopped vehicle traffic.

In DF-70, the timber ramp sections were again used at the transition from sea ice to land at VXE-6 Hill, but as the sea ice surface deteriorated a timber planked roadway (Figure 4) was field fabricated to bridge potholes and other surface irregularities. During each austral summer since DF-70, timber ramp sections have been used to span the tide cracks and a field fabricated timber planked roadway has been used where surface deterioration of the sea ice occurred. The timber ramp sections and roadway are expensive and time consuming to construct and have minimal salvage. Maintenance and repair of the timber ramp and roadway required constant vigilance.

Tests by NCEL at Williams Field in DF-69 demonstrated that an 18-inch thick earth overlay on snow provided a durable roadway for wheeled vehicles. The test also showed that deterioration of the snow surface at the ends of the earth overlay was very rapid. During the austral summer of DF-70, NSFPA began construction of an earth overlay at the snow to land transition near Scott Base. Placement of earth overlay at this transition continued during the summer seasons of DF-71 and 72. During the summer as the snow road deteriorated at the end of the earth overlay, the earth overlay was lengthened to cover the area that had deteriorated. By the end of DF-72, the earth overlay extended about 2500 feet past the shoreline.

At the present time, the end of the earth overlay is adjacent to a cliff which shades about 300 feet of adjacent roadway several hours each day (Figure 5). The shade reduces exposure to solar radiation and decreases deterioration of the snow road. Extension of the earth overlay past its present location will increase deterioration of the snow road and impede vehicular traffic.

CONCEPT

To improve trafficability of the transition zones, various construction techniques and maintenance procedures were reviewed and analyzed to determine the most satisfactory concept for each location. Since the problems encountered at each transition zone are different, the concepts for improving trafficability are also different.

A review of problems encountered at the transition from sea ice to snow indicated improved construction techniques will alleviate snow accumulation and downwarping problems that hinder vehicular traffic.

Review of problems encountered at the transitions from sea ice and snow to land indicated that surfacing material is required to prevent deterioration of the sea ice and snow roadway near the transitions. At the transition from sea ice to land, surfacing material must be structurally capable of supporting wheeled vehicles over 3-foot wide tide cracks. To reduce construction time, prefabricated or shop-fabricated surfacing materials should be used in place of the field fabricated timber roadway. An in-service field test will be required to determine what type of surfacing materials is best suited for use at McMurdo Station.

SELECTION OF SURFACING MATERIAL

Prefabricated Surfacing Materials

A survey of aircraft runway planking and roadway matting showed that many prefabricated surfacing materials suitable for use at the transitions from sea ice and snow to land are produced commercially (Table 1). Because of availability, only AM₂ planking and

a plastic matting called Mo-mat were selected for testing at McMurdo Station. Comparisons of these two materials provide sufficient data to evaluate the various types of prefabricated surfacing material.

The AM₂ aluminum planking is a system of interlocking double faced extruded panels 2 feet wide by 12 feet long by 1.5-inches thick. The panels have a bonded non-skid wearing surface on one side and interlock on their long side to form a 12-foot wide roadway. For the transition improvement field tests, sixty-four AM₂ aluminum panels were obtained from the Construction Battalion Center, Port Hueneme, California, and shipped to McMurdo Station.

Mo-mat is fabricated from fiberglass reinforced plastic in 12-foot wide by 48.5-foot long panels. For structural strength, panels are molded into a waffle configuration with an overall thickness of 5/8 inch and a material thickness of 1/10 inch. The panels have a non-skid material bonded to the top surface and holes on the periphery for connecting one panel to another or attaching edge stiffeners and anchor plates. Plastic nut plate strips are used in conjunction with bolts and washers to attach edge stiffeners or joining panels. The panels are shipped in rolls 3 to 4 feet in diameter. For the transition improvement field tests, five Mo-mat panels were obtained from CBC, Port Hueneme, California, and shipped to McMurdo Station.

Heat transfer calculations indicated that high solar radiation and above freezing air temperature will cause melting beneath AM₂ and Mo-mat placed on snow or ice. Accurate data is not available on solar radiation intensity at McMurdo, so precise calculations to determine the amount of melting beneath surfacing material of these types could not be made. The necessity to prevent melting beneath surfacing materials was therefore selected as a parameter to be studied during tests on improving trafficability of transition zones.

Two methods exist for preventing or reducing melting beneath surfacing materials: reflect solar radiation or insulate against heat transfer. Standard AM₂ aluminum planking has a dark green non-skid wearing surface. Solar radiation absorption factors* of various colors indicated that solar energy absorbed by AM₂ aluminum panels could be reduced up to 50 percent by painting the wearing surface white. For comparison of solar radiation absorption rates for light and dark colored materials, half of the AM₂ aluminum panels obtained for field tests at McMurdo Station were painted white. The remainder of the aluminum panels were left dark green. To fully cover the dark colored wearing surface, two coats of white epoxy paint were applied to the aluminum panels. The first coat had a wet film thickness of 6 mils and the second coat which was applied 24 hours later had a thickness of 12 mils. Labor and material for painting 32 aluminum panels averaged \$1.10 per square foot of wearing surface.

Many types of insulation are available which could be used to prevent melting beneath surfacing materials. However, all insulations lose their thermal resistance when saturated with water. Free standing water is common on the sea ice during December and January. Heat transfer calculations indicated that 1/4-inch thick plywood greatly reduces

* Clifford Strock. Handbook of Air Conditioning, Heating, and Ventilating. New York, The Industrial Press, 1959, p. 1-181.

melting beneath AM₂ aluminum planking or Mo-mat placed on sea ice or snow. Plywood is also low in cost compared to commercial insulation and easier to salvage. To evaluate the performance of plywood in preventing melting beneath surfacing materials on sea ice, twenty-one sheets of 1/4-inch plywood were allocated for use in the transition improvement field tests. The plywood sheets were placed under an 80-foot long section of Mo-mat.

Shop-Fabricated Surfacing Materials

Because of the high cost of prefabricated surfacing materials (Table 2) and the need for a structural system to span the tide crack, NCEL designed two timber surfacing systems. A flexible timber system using 6x6 timbers tied together with steel cables was designed (NAVFAC Drawing No. 943603) as a substitute for the prefabricated surfacing material. The flexible timber decking system is approximately 50 percent cheaper than either AM₂ aluminum planking or Mo-mat (Table 2).

Since none of the prefabricated surfacing materials are structurally adequate to span a tide crack under the anticipated loading, NCEL designed a rigid timber panel (NAVFAC Drawing No. 943604). The rigid timber panel utilized 6x6 timbers placed longitudinally and tied together transversely with steel bars 2 feet on center. The panel was designed to span a 36-inch wide tide crack. The basic function of the rigid timber panel is the same as the timber ramp sections used at the sea ice to land transition at McMurdo Station during the austral summers between DF-69 and DF-72. The rigid timber panels were designed to be more durable than the timber ramp sections.

FIELD INVESTIGATION

Port Hueneme Tests of Flexible Timber Ramp System

A prototype flexible timber ramp similar to NAVFAC Drawing Number 943603 was tested on a level paved road and beach sand in the NCEL compound at Port Hueneme, California, in August 1972. The ramp was composed of two test sections. Test section A used 11-foot long rough cut 6x6 timbers placed transverse to the direction of traffic; test section B used 4-foot and 11-foot long rough cut 6x6 timbers placed transverse to the direction of traffic configured to form two parallel tracks.

Material cost for this type of ramp is reduced by using spacers between the timbers. Measurements of 11.00x15 high-flotation tires indicated that the distance between timbers could be as great as 4 inches. If the spacing is greater than 4 inches, vehicles with this size tire or smaller will experience rough rides when traversing the ramp. A 4-inch space was maintained between the timbers in the prototype flexible ramp by placing 1/2-inch pipe nipples over the 3/8-inch longitudinal cables (Figure 6). A 4-inch space between each timber reduced the cost of prototype ramp by 30 percent per linear foot.

A Dodge W-500 equipped with 19.75x20 high-flotation tires was used to traverse the prototype ramp fifty to sixty times (Figure 7). Observations were made to determine the effects of traffic on the durability of the two test sections. When placed on a hard, level road, the Dodge W-500 caused very little movement in the ramp and no damage. However, when placed on beach sand, the timbers in both test sections twisted as the Dodge W-500 traversed the ramp. As the timbers twisted, the pipe spacers cut into the wood. After only a few passes with the Dodge W-500, each timber had a hole worn at each spacer. Inspection of the prototype ramp indicated that except for wear around the pipe spacers, the performance of both test sections was satisfactory.

It was concluded from these tests that a flexible timber ramp configured similar to test section B, except with wood spacers instead of pipe spacers, would be tested at McMurdo Station.

McMurdo Station Tests

The six sections of surfacing material listed in Table 2 were installed on sea ice to land transition zone at VXE-6 Hill during the second week of November 1972. Test section 1 spanned the tide crack at the sea ice to land interface. All other test sections were placed on the sea ice in the order list in Table 2. Test section 1 was a 16-foot long rigid timber panel similar to NAVFAC Drawing Number 943604. The panel was assembled on a low bed trailer in the Public Works garage at McMurdo in about 30 man-hours. This figure would be much higher if assembly had been at the test site instead of in a heated building.

Test section 2 was a 28-foot long flexible timber surfacing system similar to NAVFAC Drawing Number 943603. The timbers for this test section were cut to size and drilled to accommodate 3/8-inch wire rope ties in the builders shop at McMurdo Station. In lieu of pipe spacers, as used in the Port Hueneme tests, 2x6x12-inch wood spacers were nailed to the 6x6 timbers at each cable (see NAVFAC Drawing No. 943603). The flexible timber section was assembled on the sea ice near the test site in 24 man-hours. All timbers in test section 2 were redrilled in the field during assembly because the holes for the wire rope were plugged with snow and wood shavings. The timbers had been stored in the open and snow had accumulated in the holes. Test sections 1 and 2 were pinned together with 3/4-inch bolts (Figure 8) and towed into position at the test site (Figure 9).

Test sections 3 and 4 each consisted of 32 AM₂ aluminum panels. The panels in test section 3 had natural dark green wearing surface. The panels in test section 4 were painted white to reflect solar radiation. To provide a smooth transition between the 6-inch thick flexible timber section (test section 2) and the 1-1/2-inch thick AM₂ panels, a 4-inch high snow ramp with 3/4-inch plywood insulation was built beneath the first four AM₂ panels in test section 3 (Figure 10). Test sections 3 and 4 were installed in 6 man-hours.

Mo-mat was used as the surfacing material in test sections 5 and 6. Test section 5 consisted of 80 linear feet of Mo-mat with a layer of 1/4-inch plywood insulation beneath it. Test section 6 consisted of 180-feet of Mo-mat placed directly on the sea ice surface.

Because of its low weight, about 1.0 lb/ft^2 , Mo-mat must be anchored or weighed down to resist wind loads. An anchoring system of 2x4 posts frozen in sea ice was used in test sections 5 and 6. Posts were placed in holes drilled in the sea ice about 3-feet from the edge of the Mo-mat at 25-foot intervals. Rope ties (Figure 11) were used to connect the Mo-mat to the anchor posts. Test sections 5 and 6 were installed in 10 man-hours.

All tests sections performed satisfactorily until late November when melting was observed under test section 3. All AM₂ planks in test section 3, except those used in the snow ramp to test section 2 (Figure 10), had sunk into the sea ice one inch or more. Melting beneath some planks was as great as 3-inches (Figure 12).

During late November and early December, three cracks developed in sea ice parallel to the shoreline through the test site (Figure 13). The width of these cracks varied from a maximum of 4-inches to a minimum of less than an inch. The cracks were located about 20-feet, 50-feet, and 130-feet from the shoreline. In early December, deterioration of the sea ice in test sections 3 and 4 was intensified because of frequent flooding of the test site with sea water. During periods of high tide, test sections 3 and 4 were flooded with 2- to 3-inches of seawater which flowed through the cracks in the sea ice.

On 7 December 1972, the surface of the sea ice under and around test sections 3 and 4 had melted 2- to 6-inches. Surface melting had also occurred on all sides of test sections 5 and 6 and made traversing of the ramp approach very difficult. Relocation and extension of the ramp was required to put it back in reliable service. The ramp was closed to traffic for ten hours on the night of 8 December and the following work was performed: (1) test sections 3, 4, 5, and 6 were taken up; (2) three timber sleds, about 12-feet wide by 16-feet long, were placed on the seaward end of test section 2 and about 15 yards of earth fill was placed at the end of the timber sleds; (3) the earth fill was leveled and AM₂ aluminum planking was placed over 1/4-inch plywood on top of the earth fill; and (4) 250-feet of Mo-mat with 3/4-inch plywood insulation beneath it was placed at an angle to test site (Figure 14).

During relocation of the surfacing material on 8 December 1972, a major disadvantage in using AM₂ planking in cold regions was observed. When the aluminum matting was disassembled, water on the AM₂ planking froze. Ice in the interlocking joints of the AM₂ planking had to be melted and chipped away before it could be used again. About 6 man-hours was required to remove ice from the interlocking joints of the AM₂ planking.

Rapid surface deterioration and extensive cracking in the sea ice near the shoreline resulted in termination of the test program in mid December. In an effort to prolong use of the sea ice road, Public Works, NSFPA, fabricated and installed two 50-foot-long steel ramps at the sea ice to land interface and placed 400-feet of earthfill roadway on the sea ice. A timber planked roadway similar to Figure 4 was field fabricated on the earth fill.

Both sides of the earth fill roadway was flooded with 6-inches of water a few days after its construction. The sea ice road was closed to traffic on 26 December when a free floating section of ice under the roadway sank 16-inches below sea level. Sinking of the ice was attributed to overloading with earth fill.

APPLICATION

Sea Ice to Snow Transition

Review of problems encountered at the transition from sea ice to snow indicated improved construction techniques will alleviate the conditions that hinder vehicular traffic. Snowdrift accumulation can be reduced by constructing the snow ramp at least 75-feet wide and rounding the shoulders of the cut in the ice shelf. The difference in elevation between the sea ice and the ice shelf is about 15-feet. For wheeled vehicles to maintain traction on the snow ramp under all weather conditions the grade of the ramp should not exceed 10 percent.

Downwarped area and pressure ridges in the sea ice are normally caused by ice shelf movement. Both are common along the ice shelf.* The magnitude and extent of downwarping depend on the position and configuration of the ice shelf edge. Downwarping may also be caused by surface loading the sea ice. The snow ramp at the transition from sea ice and snow should be constructed at a site where downwarping has not occurred, and should be cut into the ice shelf as far as possible to minimize surface loading of the sea ice (Figure 15).

Snow to Land Transition

The snow to land transition near Scott Base required 75 to 100 feet of surfacing material to reduce the amount of dirt tracked onto the snow road. The flexible timber surfacing system (Figure A-1) is better suited for this transition than prefabricated surfacing materials because it has openings to collect dirt. Prefabricated surfacing materials become covered with dirt, therefore, ineffective in preventing tracking of dirt onto the snow road. The flexible timber surfacing system also has the advantage that it cost about 60 percent less than prefabricated surfacing materials.

Since the rate of snow accumulation is high at this transition, the flexible timber surfacing material should be stored at some other location during the winter. If the flexible timber surfacing material is fabricated as shown in NAVFAC Drawing No. 943603, each 20-foot length may be towed to a snow free location at the end of each summer season.

The surfacing material should be installed at the transition each summer when the snow road is open to traffic. The end of the surfacing material nearest the ice shelf should be buried as shown in Figure 16. Burying the end of the surfacing material will provide a smoother transition onto the ramp. The section of flexible timber surfacing material should be tied together as shown in Figure 16 so the entire ramp acts as a unit.

* Naval Civil Engineering Laboratory. Technical Note N-840, Ice and Snow Terrain Features, McMurdo Station, Antarctica, by R. A. Paige, Port Hueneme, California, September 1966.

Sea Ice to Land Transition

Field tests and observations indicate that a minimum of 75-feet of timber ramps or rigid timber panels (Figure A-2) and 500-feet of surfacing material is required at the VXE-6 Hill sea ice to land transition. The first timber ramp or rigid timber panel should be placed over the tide crack at sea ice and land interface and the remainder of the ramps or panels placed on the sea ice.

Because of rapid deterioration at locations where vehicles track dirt on the sea ice, several approaches to the surfacing material should be provided. The prefabricated surfacing material such as Mo-mat and AM₂ aluminum planking are better suited for multiple approaches than the flexible timber system because they are thin. Mo-mat is 0.63-inches thick and AM₂ planking is 1.5-inches thick compared to 6-inches for the flexible timber system.

The approaches to the surfacing material should be regulated so that dirt is not tracked onto the sea ice indiscriminately. The approach to the surfacing material should initially be at the seaward end. As the sea ice at one location deteriorates, the approach should be re-located closer to shore. Deterioration of the sea ice can be reduced by keeping a clean snow cover on the sea ice adjacent to the surfacing material until used as a vehicle approach.

FINDINGS

1. AM₂ aluminum planking is suitable for use as surfacing material on sea ice, but requires some type of insulation between it and the sea ice to prevent surface melting.
2. Ice in the joints of the AM₂ planking will prevent the panels from interlocking.
3. Five hundred feet of surfacing material is required at VX-6 Hill to provide a usable maintenance-free transition ramp until mid December.
4. The flexible timber system is an economical surfacing material, but it is limited to use at locations where vehicle access is bidirectional.
5. Mo-mat is suitable for use as surfacing material on sea ice, but it must be well anchored and insulation is required between it and the sea ice to prevent surface melting.
6. Plywood, 1/4-inch thick, did not eliminate melting of the sea ice surface beneath Mo-mat. However 1/4-inch thick plywood did reduce the amount of melting beneath the Mo-mat.
7. Mo-mat is easier to install and recover than AM₂ aluminum planking when used on ice or snow.

CONCLUSIONS

1. Prefabricated surfacing material may be used to provide a low maintenance roadway at the transition zone from sea ice to land. Of the two prefabricated surfacing materials tested, AM₂ aluminum planking is the most durable. However, Mo-mat is durable enough to withstand vehicular loading encountered at the sea ice to land transition if it is properly anchored.
2. Installation and recovery of AM₂ aluminum planking is more difficult than Mo-mat.
3. Any of the prefabricated or shop fabricated material tests may be used at the transition from snow to land, but because of its low cost and ability to collect dirt, the flexible timber system should be used.

Table 1. Tabular Summary of Prefabricated Aircraft Runway
Planking and Roadway Matting*

Item	Federal Stock Number	Source	Cost (\$/ft ²)	Weight (lb/ft ²)	Panel Dimensions
Aluminum Mats					
AM ₁		Butler Mfg Co Kansas City, MO			12 ft x 2 ft x 2 in.
AM ₂	5680 072 8680	Harvey Aluminum Co. Torrance, CA	3.00 (1961)	6.3	12 ft x 2 ft x 1.5 in.
AM ₃		Alcoa New Kensington, PA		7.87	8.11 ft x 3.27 ft x 5.5 in.
AM ₅				4.31	12 ft x 2 ft x 1.5 in.
AM ₆		Harvey Aluminum Co. Torrance, CA	4.50 (1971)	3.7	12 ft x 2 ft x 1 in.
M9M1			1.32 (1971)	5.3	12 ft x 2 ft x 1.7 in.
M9M2			1.32 (1971)	7.6	12 ft x 2 ft x 1.9 in.
XM18	5680-089-7260	Dow Chemical Co Midland, MI	5.30	4.8	12 ft x 2 ft x 1.5 in.
XM18L1		Dow Chemical Co Midland, MI	3.72 (1971)	4.8	12 ft x 2 ft x 1.5 in.
XM19	5680 089 5920	Kaiser Aluminum and Chemical Sales Co. Oakland, CA	5.00 (1970)	4.1	4.19 ft x 4.13 ft x 1.5 in.
XM19 All Bonded		Kaiser Aluminum and Chemical Sales Co. Oakland, CA		4.25	4.19 ft x 4.13 ft x 1.5 in.
XM20		Dow Chemical Co. Madison, IL	4.35 (1968)	6.08	12 ft x 2 ft x 1.5 in.
Goodyear All Bonded		Goodyear Aero-space Corp. Akron, OH	4.00 (1971)	3.99	4.08 ft x 4.08 ft x 1.5 in.
Harvey 1- by 6 feet		Harvey Aluminum Co. Torrance, CA	4.00 (1971)	4.6	6 ft x 1 ft x 1.5 in.
Modified T11		Dow Chemical Co. Madison, IL	3.00 (1968)	4.5	12 ft x 2.16 ft x 1.6 in.

continued

* Naval Civil Engineering Laboratory. Technical Note N-1212, Marginal Terrain Platforms, by A. Widawsky, Port Hueneme, California, June 1972.

Table 1. Continued

Item	Federal Stock Number	Source	Cost (\$/ft ²)	Weight (lb/ft ²)	Panel Dimensions
Aluminum Mats (continued)					
Alcoa T11		Alcoa New Kensington, PA		3.8	12 ft x 2 ft x 1.6 in.
Fenestra				5.0	8.5 ft x 1.78 ft x 1 in.
Aluminum Trackway			2.38 (1967)	4.10	25.5 ft x 11 ft
Plastic Mats					
Mo-Mat	5680-806-0864	Air Logistics Corporation Pasadena, CA	3.65 (1971)	1.0	48.5 ft x 12.17 ft x 0.63 in.
Modified T12		Strato-Tek Los Angeles, CA		4.44	12 ft x 2 ft x 1.2 in.
T13		Lunn Laminates Huntington Sta., NY		5.40	12 ft x 3 ft x 1.8 in.
T14		Pacific Plastic Co Seattle, WA		6.29	11.87 ft x 1.85 ft x 1.75 in.
Magnesium Mats					
T7		Dow Chemical Co Madison, IL		3.93	12 ft x 1.65 ft x 1.63 in.
T8		Dow Chemical Co Madison, IL		4.27	12 ft x 2.29 ft x 1.63 in.
Steel Mats					
M8		Military	0.56 (1971)	6.96 7.27	11.81 ft x 1.63 ft x 1.14 in.
M8A1	5680-782-5577	Kaiser Steel Fontana, CA	1.00 (1971)	7.5	11.81 ft x 1.63 ft x 1.13 in.
U.S. Steel 3.5A		U.S. Steel		3.6	4 ft x 4 ft x 1.5 in.
U.S. Steel 4.5A		U.S. Steel		4.9	4 ft x 4 ft x 1.6 in.

Table 2. Surfacing Material Tested at the McMurdo Station
Sea Ice to Land Transition

Test Section Number	Material	Length of Test Section (ft)	Cost (\$/ft ²)
1	Rigid Timber	16	2.00 ^d
2	Flexible Timber	28	1.10 ^d
3	AM ₂ Aluminum Planking (Standard)	64	4.10
4	AM ₂ Aluminum Planking (White Surface)	64	3.00
5	Mo-Mat (with 1/4-inch plywood)	80	3.30
6	Mo-Mat	160	3.05

^d Material cost only; labor for fabrication and assembly not included.

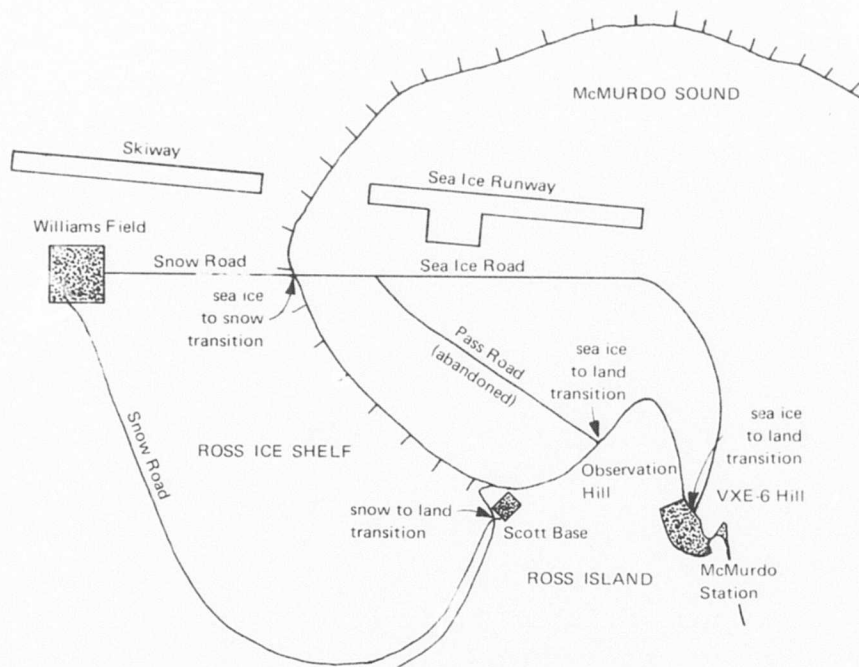

Figure 1. Map of McMurdo Station road system.

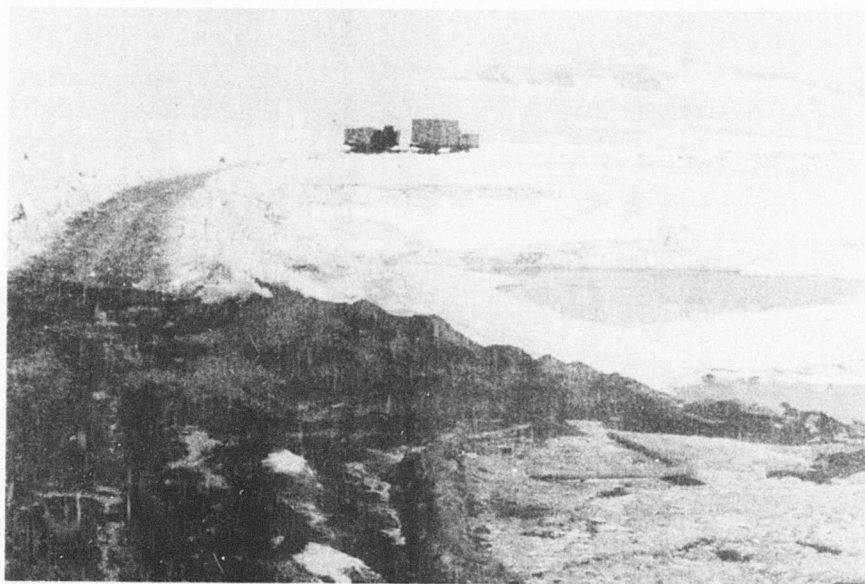

Figure 2. Compacted snow roadway at Pass Road.



Figure 3. Timber ramp constructed during DF-68 at sea ice to land transition.

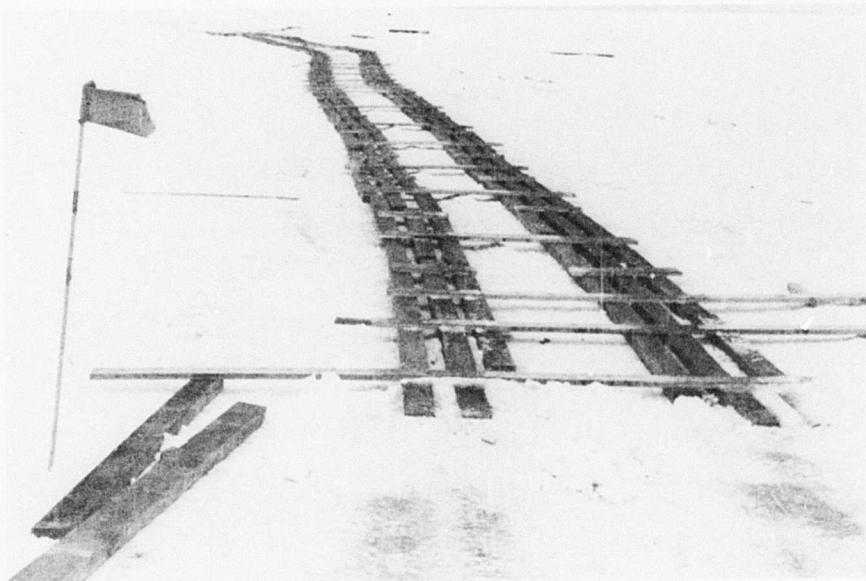

Figure 4. Field fabricated timber planked roadway.



Figure 5. Shaded section of snow road near Scott Base.



Figure 6. Prototype flexible timber ramp being assembled using 4-inch long pipe nipples as spacers.



Figure 7. Dodge W-500 traversing prototype timber ramp on beach sand.

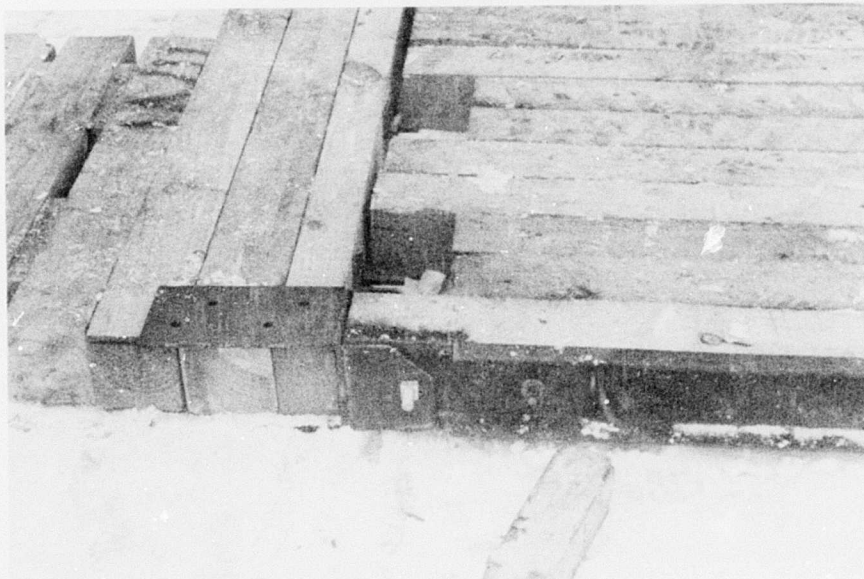

Figure 8. Pin assemble between rigid and flexible timber surfacing systems.



Figure 9. Timber test sections being moved into place.

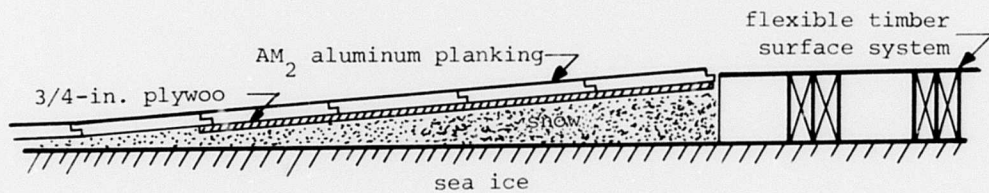

Figure 10. Snow ramp between test sections 2 and 3.

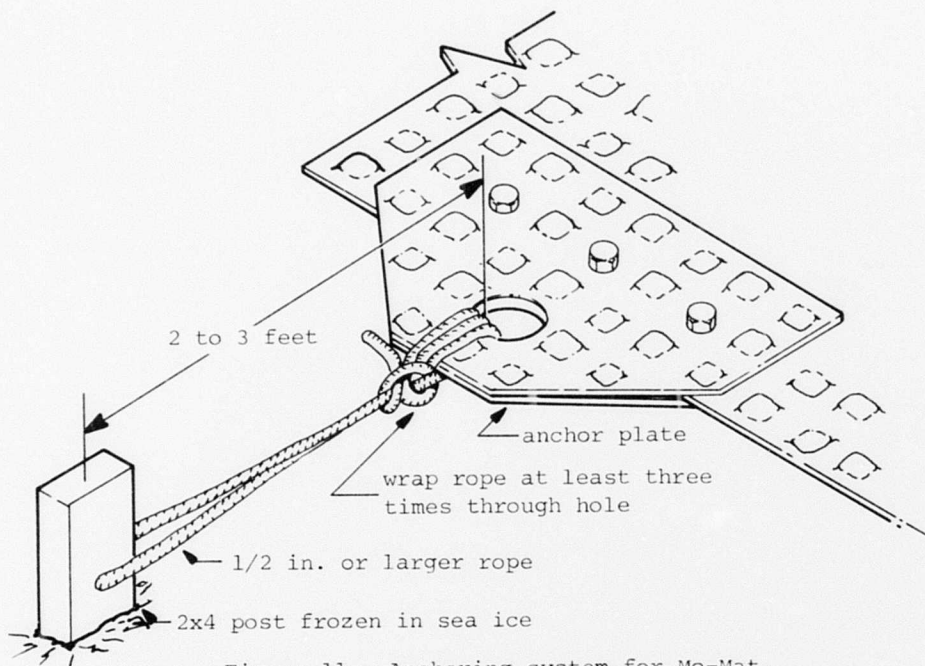

Figure 11. Anchoring system for Mo-Mat.



Figure 12. AM_2 aluminum planking after melting occurred.

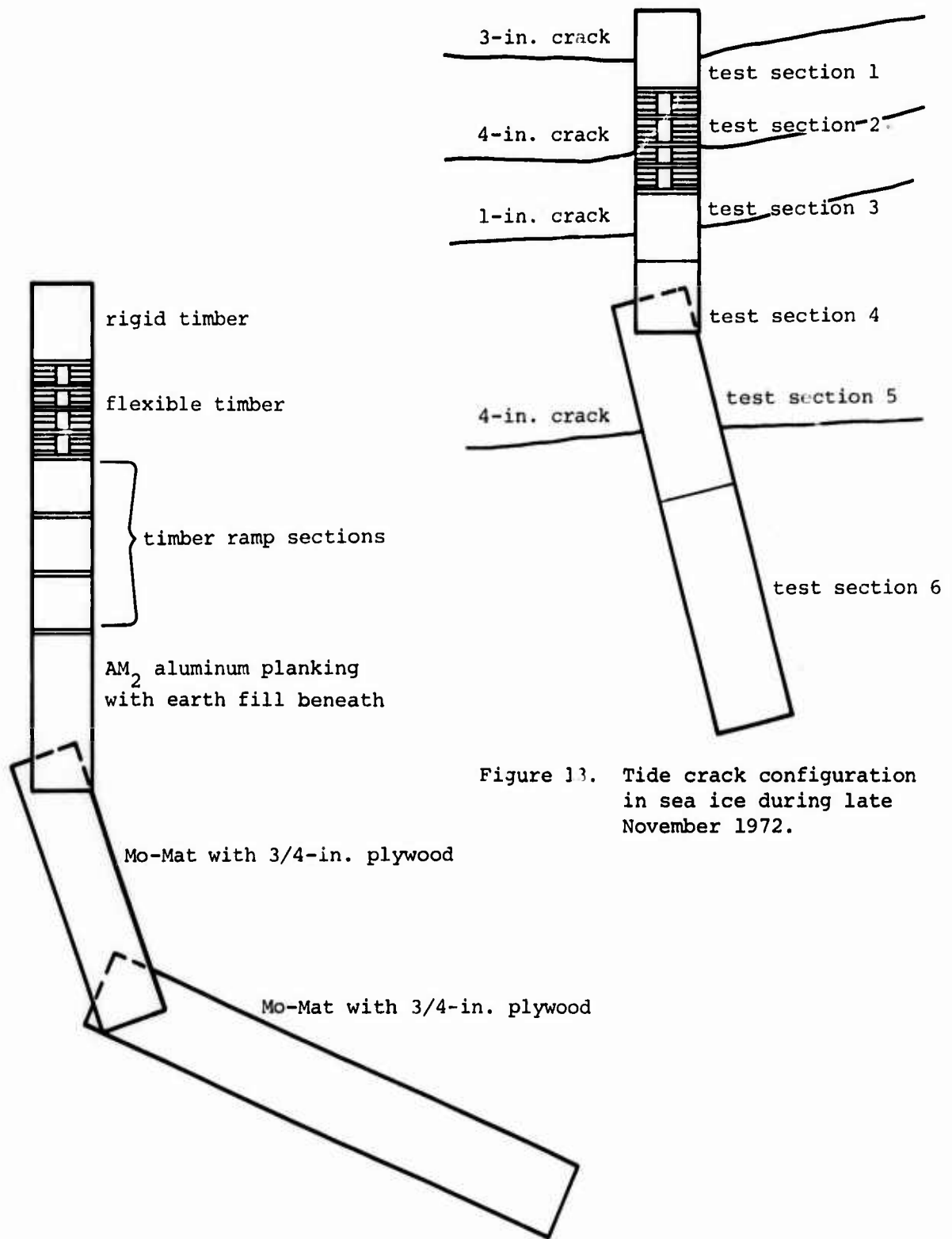

Figure 13. Tide crack configuration in sea ice during late November 1972.

Figure 14. Ramp configuration on 9 December 1972.

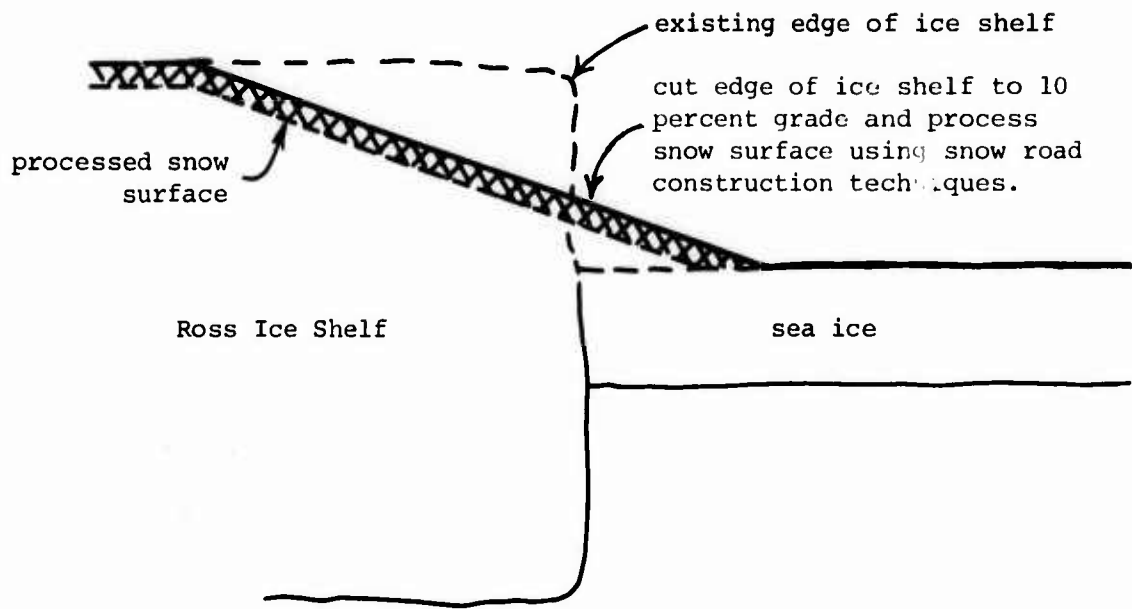

Figure 15. Sea ice to snow transition.

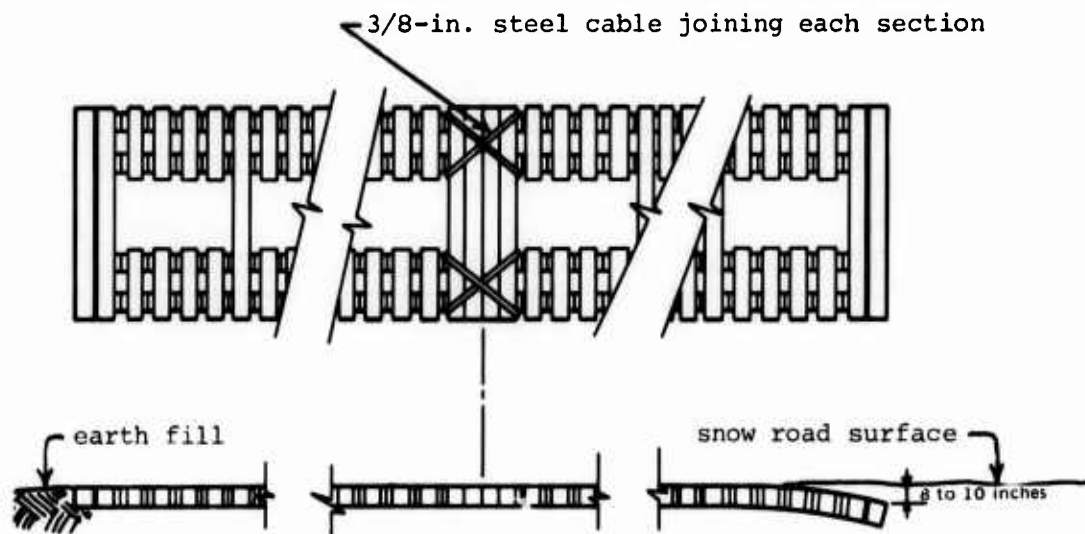
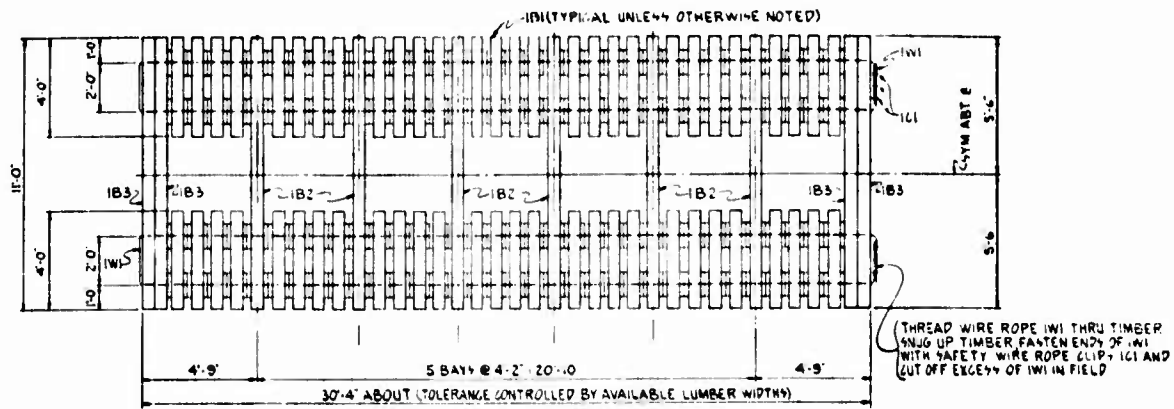
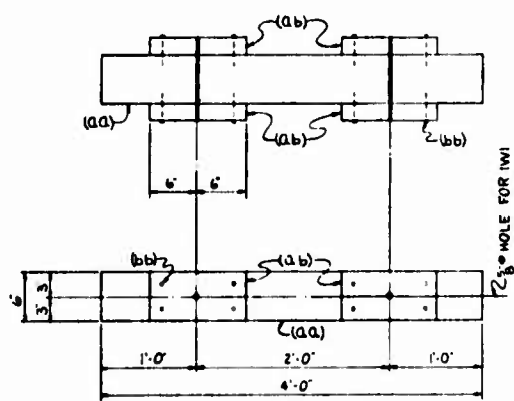

Figure 16. Installation of flexible timber surfacing material.



ERECTION PLAN (FIELD ASSEMBLY)



56-WOOD BEAM⁴-IB1

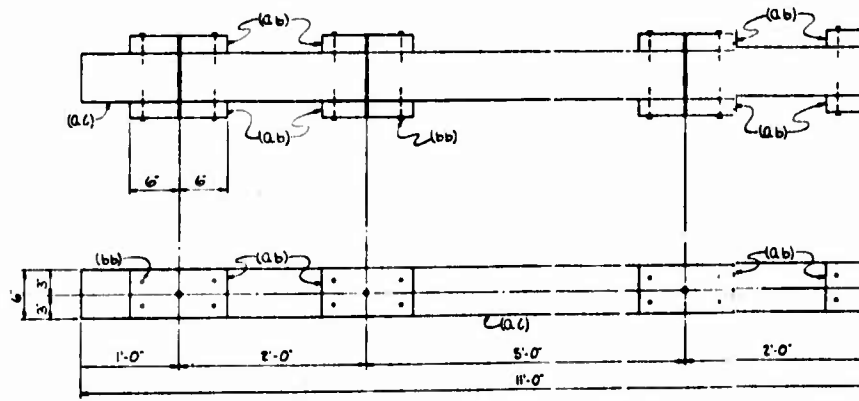

6-WOOD TIE BEAM⁴-IB2

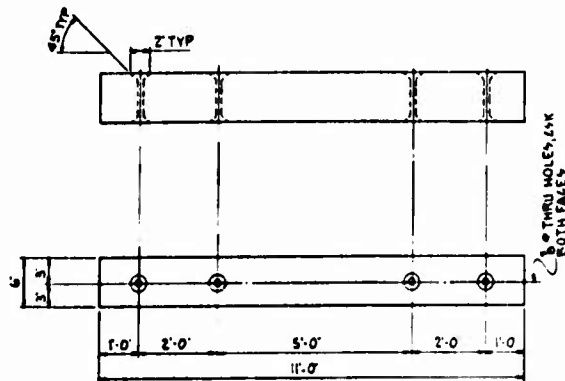

4-WOOD END BEAM⁴-IB3

Figure A-1. Flexible timber ram

B



WIRE ROPE (WI) THRU TIMBER
TIMBER FASTENERS TO WI
ETY WIRE ROPE CLIP (IC) AND
KCE99 OF WI IN FIELD

NOTE 4

ALL LUMBER TO BE DOUGLASS FIR CONSTRUCTION GRADE,
ROUGH SAWN.

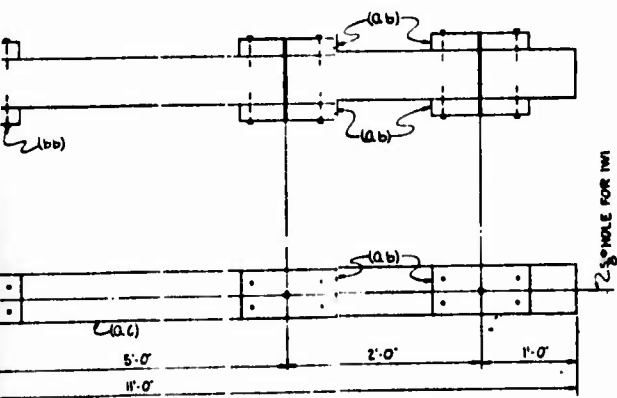

6-WOOD TIE BEAM- B2

2	BOFS, 5/16-25 FILLER WIRE, IWR 2, IMPROVED FLOW STEEL GALVANIZED				
	2-TIE CABLES-WI (NOT DETAILED)				
6	WIRE ROPE SAFETY CLIPS FOR 3/4" WIRE ROPE, GALVANIZED				
	6-CLIP (IC) (NOT DETAILED)				
4	4x4	11	0		
	4-WOOD END BEAM-IB3				
bb	NAILS BILLED UNDER (IB)				
QC	6	6x6	11	0	
Qb	48	2x6	1	0	
	6-WOOD TIE BEAM-IB2				
bb	25# 16d COMMON STEEL WIRE NAILS, GALVANIZED				
Qb	224	2x6	1	0	
QA	86	6x6	4	0	
	56-WOOD BEAM-IB1				
NO	NO	SIZE	FT	IN	QUANTITY
			LENGTH		
BILL OF MATERIAL					
PROJECT NO: 61-017		DEPARTMENT OF THE NAVY NAVAL FACILITIES ENGINEERING DIVISION			
NAVAL ENGINEERING LAB.		NAVAL CIVIL ENGINEERING LABORATORY			
73-15-1F		PORT HURDIS, CALIFORNIA			
DESIGNED BY: [Signature]		MCMURDO TRANSITION RAMPS			
CHECKED BY: [Signature]		FLEXIBLE TIMBER RAMP			
DATE: 11/13		ERECTION PLAN & DETAILS			
SCALE: 1/4" = 1'-0"		REV	CODE	DATE	DESCRIPTION
APPROVED: [Signature]		F	00001		943603
DRAWN: [Signature]		DATE	CODE	DATE	DESCRIPTION
TITLE: FLEXIBLE TIMBER RAMP					
SHEET NO: 1 OF 2		SHEET 1 OF 2			

UNLESS SPECIFIED OTHERWISE
DIMENSIONS ARE IN FEET UNLESS NOTED
FRACTIONS 1/8" UNNOTED
DECIMALS 1/16"
ANGLES 1/4"

Figure A-1. Flexible timber ramp.

Original drawing filed at NCEL, Port Hueneme, CA; available on request.

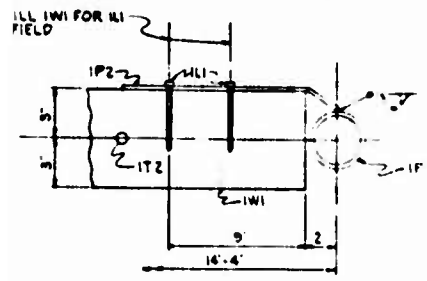

SECT A-A (TYP)

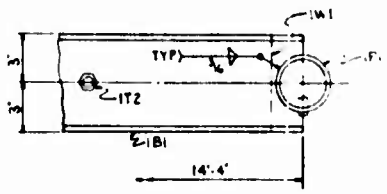

SECT B-B (TYP)

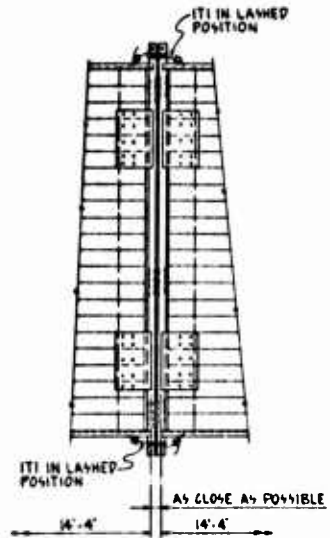

DET C (LASHING RAMP)

NOTES

1. ALL LUMBER TO BE DOUGLAS FIR CONSTRUCTION GRADE, ROUGH SAWN.

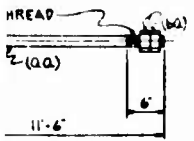

TIE RODS-I12

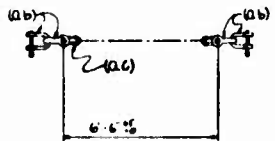

2-LASHING-I11

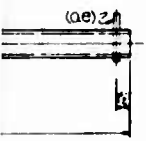

I1

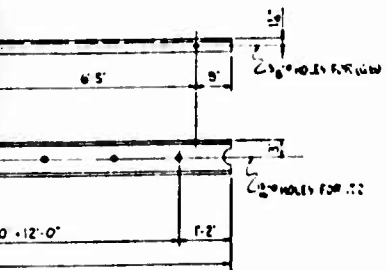

I11-I12

MARK	NO	QTY	SIZE	UNIT	LENGTH	REMARKS
			40 # 4	LAG SCREW	40	NO. 4 MILD STEEL
			40	LAG SCREW	40	(NOT DETAILED)
QC	4	BAR	3/4"		0	5/8" A 7 M A 36
Qd	2	PIPE	3"		12	6" SCH 40, A 7 M A 53, GRADE B
						2-PIPE 4-I1
						2-CHANNELS-I11
						4-PLATE 4-I12
						4-PLATE 4-I12
QC	2	3/8" x 6" x 1/2"	PROOF COIL CHAIN	NOM WIDE LINK	12	1' LENGTH x 1/2" WIDTH
Qb	8	3/8"	SCREW PIN CHAIN	SHACKLE		GALVANIZED
						2-LASHING 4-I11
Qd	20	1/2"	HEX NUT			MILD STEEL
QC	7	BAR	3/4"		11	6" A 7 M A 36, THREAD EACH END
						7-TIE RODS-I12
						22-WOOD BEAMS-I11

PROJ NO: 61-017 DEPARTMENT OF THE NAVY NAVAL FACILITIES ENGINEERING COMMAND

NCEL DIV NO: 73-15-2F NAVAL CIVIL ENGINEERING LABORATORY PLETT HARBOR, CALIFORNIA

DESIGNED BY: [Signature] CHECKED BY: [Signature] DATE: 6/1/53

MCMURDO TRANSITION RAMPS RIGID TIMBER RAMP ERECTION PLAN & DETAILS

SCALE: AS SHOWN

DATE: 6/1/53

NO. 943604

DATE: NONE SPEC: SHEET 2 OF 2

Figure A-2. Rigid timber ramp.