

AD-774 983

THE DESIGN OF AN EXPERIMENTAL HIGH ENERGY IMPACT  
TUNNELER

INGERSOLL-RAND RESEARCH, INCORPORATED

PREPARED FOR  
BUREAU OF MINES  
ADVANCED RESEARCH PROJECTS AGENCY

JUNE 1973

DISTRIBUTED BY:

**NTIS**

National Technical Information Service  
U. S. DEPARTMENT OF COMMERCE

AD 74983

RESEARCH PROGRAM ON  
THE DESIGN OF AN EXPERIMENTAL  
HIGH ENERGY IMPACT TUNNELER  
ANNUAL REPORT  
June 1973  
REPORT TM-7307

Prepared by  
Ingersoll-Rand Research, Inc.  
P. O. Box 301  
Princeton, N. J. 08540  
Phone (609) 921-9103

Author: Mukund D. Gangal  
Dr. Mukund D. Gangal  
Principal Investigator

Approved: B. R. Banerjee  
Dr. B. R. Banerjee  
Assistant Director of Research 7/77

Sponsored by  
Advanced Research Projects Agency  
ARPA Order No. 1579, Amend. 3  
Program Code 2F10

Monitored by  
Bureau of Mines  
Contract No. H0230006  
Amount of Contract \$50,000.00  
Effective Date: August 1972  
Contract Expiration: 30 June 1973

Reproduced by  
NATIONAL TECHNICAL  
INFORMATION SERVICE  
U S Department of Commerce  
Springfield VA 22151

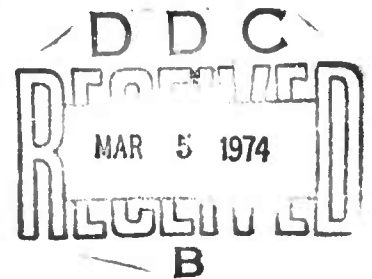

DISTRIBUTION STATEMENT A  
Approved for public release;  
Distribution Unlimited

Unclassified

3200.8 (Att 1 to Encl 1)  
Mar 7, 66

Security Classification

DOCUMENT CONTROL DATA - R & D

(Security classification of title, body of abstract and indexing annotation must be entered when the overall report is classified)

1. ORIGINATING ACTIVITY (Corporate author) Ingersoll-Rand Research, Inc. P. O. Box 301 Princeton, New Jersey 08540		2a. REPORT SECURITY CLASSIFICATION UNCLASSIFIED	
		2b. GROUP	
3. REPORT TITLE The Design of an Experimental High Energy Impact Tunneler			
4. DESCRIPTIVE NOTES (Type of report and inclusive dates) Annual Report - October - June 1973			
5. AUTHOR(S) (First name, middle initial, last name) Mukund D. Gangal			
6. REPORT DATE June 1973		7a. TOTAL NO. OF PAGES 50	7b. NO. OF REFS 12
8a. CONTRACT OR GRANT NO. H0230006		9a. ORIGINATOR'S REPORT NUMBER(S) TM- 7307	
b. PROJECT NO. ARPA Order No. 1579			
c. Amendment 3		9b. OTHER REPORT NO(S) (Any other numbers that may be assigned this report)	
d. Program Code 2F10			
10. DISTRIBUTION STATEMENT Distribution of this document is unlimited.			
11. SUPPLEMENTARY NOTES		12. SPONSORING MILITARY ACTIVITY Defense Advanced Research Projects Agency 1400 Wilson Boulevard Arlington, VA 22209	
13. ABSTRACT The research program emphasized the field testing of a medium energy impact breaker IMP-1000. Quantitative data were obtained on the effect of the variation of blow energy, blow spacing and tool point geometry on the amount of rock broken during the excavation. Motion picture records and other qualitative observations were made. In addition to the field work, Demon 300 tool was repaired for future use, an impactor capable of delivering 50,000 ft. lb/blow was sized up and laboratory rock tests were conducted to obtain qualitative data on edge fracture.			

DD FORM 1 NOV 65 1473

Unclassified  
Security Classification

1a

Unclassified  
Security Classification

3200.8 (Att 1 to Encl 1)  
Mar 7, 66

14. KEY WORDS	LINK A		LINK B		LINK C	
	ROLE	WT	ROLE	WT	ROLE	WT
Breakage, Rock Impact Fragmentation Hammer, Hydraulic Fracture						

ib

Unclassified  
Security Classification

The views and conclusions contained in this document are those of the authors and should not be interpreted as necessarily representing the official policies either expressed or implied, of the Advanced Research Projects Agency or the United States Government.

*ic*

TABLE OF CONTENTS

TECHNICAL SUMMARY	1
I. OBJECTIVES AND SCOPE	3
II. SURVEY OF RELEVANT DEVELOPMENTS AND LITERATURE	5
III. MAJOR ACCOMPLISHMENTS	9
Field Test of IMP-1000	9
A. Background	9
B. Adapting the tool to the mounting	9
C. Calibration	9
D. Field Test #1	10
E. Field Test #2	13
F. Field Test #3	13
G. Observations and Conclusions	13
Repair of Demon - 300	16
Rock Testing	17
Unidirectional Benching	17
Bidirectional Benching	18
Sizing a 50,000 ft. lb. Impactor	19
IV. CONCLUSIONS AND RECOMMENDATIONS FOR FUTURE WORK	21
V. REFERENCES	24
TABLES	25
FIGURES	28
PLATES	35

## LIST OF TABLES

<u>Table No.</u>		<u>Page No.</u>
1	Comparative specific Fracture Energies for various techniques	25
2	Details of Proprietary Impact Units	26
3	Experimental Observations	27

## LIST OF FIGURES

<u>Fig No.</u>		<u>Page No.</u>
1	Control Circuit	28
2	Effect of Tool Tip Geometry on Specific Energy and Blow Spacing	29
3	Effect of Blow Energy on Specific Energy and Blow Spacing	30
4	Effect of Rock Strength on Tool Performance at Optimum Blow Spacing	31
5	Unidirectional Benching	32
6	Bidirectional Benching	33
7	High Energy Impact Tool	34

## LIST OF PLATES

<u>Plate No.</u>		<u>Page No.</u>
1	IMP-1000 unit	35
2	Hydraulic Control Valve System	35
3(a)	Rock Face Chosen for Test	36
(b)	Close-up of Test Area	36
4(a)	Start of The Test	37
(b)	Marked up Test Area	37
5	Blunt Tool Tip	38
6	Pointed Tool Tip	38
7	Progress of Excavation	39
8	Progress of Excavation (shows rock gathering system in the tests)	39
9	Bent Guide Tube a-b	40
10	Progress of Excavation a-b	41
11	Progress of Excavation	42
12	Progress of Excavation Close-up	43
13	Goblin Mounted on Back-hoe	44
14	Cracks in Demon 300 a-b	45
15(a)	Grid Pattern	46
(b)	First Edge Cut	46
(c)	Second Edge Cut	46
(d)	Third Edge Cut	46
16	Experiment in Bidirectional Benching	47
17	Clean Bidirectional Breakout a-b	48

## TECHNICAL SUMMARY

The present program\* had the following technical objectives:

1. Conduct field test using an experimental medium energy impact unit IMP-1000.
2. Repair another experimental impactor Demon-300 for future use.
3. Size up an impactor capable of delivering 50,000 ft. lbs./blow.
4. Conduct laboratory rock testing related to edge fracturing.

All the technical objectives were achieved during the research program and some quantitative as well as qualitative observations were made on rock excavation which will be useful in any continuing effort aimed at demonstrating applicability of high energy impact for tunneling. A survey of the technical literature on work done at the British Coal Board, at the Russian Mining Institute and in this country at Anaconda Research Facility in Butte, Montana, is presented.

Conclusions and observations from this program are listed below:

- a. Increase in blow energy results in increased efficiency of rock excavation.
- b. As one would expect, an impactor of given blow energy works more efficiently in softer rock than in harder rock.
- c. There usually exists an optimum spacing that gives the lowest specific energy at a given blow energy in a given rock.
- d. The amount of dust produced by IMP-1000 was qualitatively judged to be small.
- e. Experimental work done with IMP-1000, the sizing study on a 50,000 ft. lb./blow impactor and the published data from Russian experiments clearly show that it is feasible to develop a high energy impact tunneling system.

---

\*As modified in January, 1973

- f. Rock testing indicated an interesting mode of rock breakage. This breakage technique, namely bidirectional benching, holds promise.
- g. Side loads produced by glancing blows continued to be a persistent problem. Future impactors must be designed to withstand side loads.
- h. Repeated blows in a single spot before indexing can yield more rock than repeated surface coverage using single blows. The optimum number of blows in a single spot and its relationship to blow energy and rock strength remains to be evaluated.
- i. Articulated impact using the operator's judgment (intelligent excavation) seems to yield more rock than orderly spaced blows; but adversely affects the repositioning time. The net economic effects need to be proven systematically.
- j. With IMP-1000 we were able to cut into the corners of the excavated area, in other words the tool showed a kerfing ability.

In summary, we have reached a take off point in developing an experimental high energy impact tunneling system.

## I. OBJECTIVES AND SCOPE

The objective of the overall research program supported by ARPA was to develop, design and build a high Energy Impact Tunneling machine and then demonstrate its ability to tunnel in hard rock on a competitive basis with existing methods (e.g. Drill & Blast). The present effort was initiated on August 1, 1972 with the main objective of sizing and preliminary design of an Impact Tool capable of delivering 50,000 ft. lbs. During a subsequent program such an Impactor was to have been built and tested to prove its tunneling ability. The original objectives of the program included the following:

1. Rebuild and strengthen Demon 300 Impactor which failed during earlier ARPA sponsored program (contract No. H 0210045).
2. Size up and lay out a 50,000 ft. lb. impactor so that in a future effort it can be designed, built and tested for tunneling applications.
3. Conduct idealized rock fracture experiments in the laboratory to obtain pertinent data on primary and secondary fracture.

However, late last year, because of the curtailment of the ARPA program, it was felt that in order to obtain the most significant data from this limited effort, we should conduct a field test using an existing medium-energy impactor, (IMP-1000) and obtain field data in rock breaking. Therefore, contract modification No. 3 was executed on January 9, 1973. The modified program consists of three phases:

1. Field Test IMP-1000: Procure IMP-1000, mount it on a backhoe and field test it at a suitable quarry and make qualitative observations.

2. Rebuilding Demon 300: Limited to rewelding the cracked casing and guide rail frame.
3. Rock Test: Limited to qualitative observations on edge fracture and other pertinent fracture parameters, depending on available time and effort.

However, before the contract modification was visualized, in response to the change in ARPA funding of tunneling research, the effort had already been completed on the sizing of an impactor capable of delivering 50,000 ft. lbs. The basis for this conceptual design was reported in the semiannual report TM 7304, (March 1973).

## II SURVEY OF RELEVANT DEVELOPMENTS AND LITERATURE

The interest in rock excavation by mechanical impact has increased rapidly during the past few years. At the moment, the Russians lead the field in the development of very high energy impact tools for tunneling and mining excavation. Under the leadership of Professor B. V. Voitsekhovskiy, they have developed<sup>1+</sup> prototype actuators capable of delivering blow energies in excess of 70,000 ft. lbs. Further, published results indicate that at these blow energies the efficiency of rock breakage is highly attractive, the specific energy\* being of the order of 2850 psi for a 30,000 psi granite.

The Russians seem to have considered problems of dynamic loading in their design; they have constructed special features to absorb side loads, produced by reactions to glancing blows. In addition, their design incorporates a long flexible connecting rod, with load absorbing features, between the piston and the tool point. This rod adds flexibility to the actuator mechanism. Ref. 1 indicates that their units have achieved cycling rates (i.e., power) up to 30 bpm.

The British Coal Board has been investigating impact rippers and excavation for soft and moderately hard rocks. Morris and Rodford<sup>2</sup> and Moore and Rodford<sup>3</sup> report upon their experience with various commercially available impact rippers having blow energies from 500 ft. lbs. to 3,000 ft. lbs. Their observations are quite interesting. Here are some of the conclusions they reached after extensive field work:

1. Impact rippers have sufficient rock removal capacity for most rips in soft strata. The cutting rate is compatible with all current gathering systems.

---

\* Specific energy,  $\bar{E}$ , is the energy required to break out a unit volume of rock.  $\bar{E}$ , has units of in. lbs./cu. in. or simply psi. The lower the specific energy, the more efficient is the process of excavation.

+ Superscripts indicate reference numbers at the end of the report

2. The dust produced is considerably less than that by pick-type mining machines.
3. Very small amount of sparking occurred when used in hard rock or strata containing ironstone bands or nodules. In most cases there will be no need to attack the ironstone as it can be removed by under and over-cutting.
4. Available equipment allows good face access.

In this country, Du Toit, of Anaconda Mining Research Center, reports<sup>4</sup> upon the experimental work conducted at Butte, Montana on impact excavation for mining. In his pioneering efforts to develop a "Mechanical Rock Pick" or MRP for short, Du Toit used an impact breaker, (Hobgoblin made by Ingersoll Rand) and tested it at a tunnel site in the Berkeley pit. After successful conclusion of the preliminary tests, he built a "Phase II" machine and obtained underground production rates of 25 tons/hr in a 14,000 psi rock at Butte. On the basis of this work Anaconda has decided to develop even more advanced systems. Du Toit<sup>4</sup>, observed the following:

The MRP system clearly promises the following progress over conventional methods:

- A) Continuous mining--24 hour excavation
- B) "Pushbutton" mining (more appealing to future labor force).
- C) Improved cost per pound of metal products:

Better grade of ore produced because of:

Better selectivity within the vein  
being mined. "No" overbreak--less  
dilution--no blasting.

D) Economical because:

- a) Lower haulage, and development cost per pound of metal.
- b) Ability to mine present nonminable veins.

E) Improved safety conditions (environmental):

- a) No blasting and, therefore:  
Better wall and back conditions, no blasting fumes-and no explosives handling hazards.
- b) Less fire hazard.
- c) Less total dust to contend with. Protective cover for man to work under at all times.

Finally an extreme example of high energy impact process is presented by what is called REAM<sup>5</sup> (Rapid Excavation and Mining), a project supported by ARPA under Contract No. H0220015. As reported by Watson, the REAM concept uses concrete projectiles fired through an M-107 self-propelled gun. Actual excavation work consisted of pre-drilling a pattern of kerfing holes and then firing concrete "bullets" to break rock off the tunnel face. On an energy basis, the gun delivered 10 lb. concrete projectiles at 5,000 ft/sec impact velocity or an equivalent of  $3.9 \times 10^6$  ft. lbs. of blow energy. With this high impact energy very low specific energies of the order of 9 joules/cc or 1300 psi were reported.

At this point it may be worthwhile to review some of the "new" tunneling techniques and compare their effectiveness. These "new" techniques include the use of water jets of various forms, lasers, electronbeam and other novel techniques.

A nondimensional specific energy\* is used as a measure of effectiveness of an excavation scheme. From the data compiled<sup>+</sup> from various sources, represented in Table 1, it seems that the mechanical impact breaking methods such as, the Impact Tunneling and REAM approaches are energetically superior to other techniques. Comparing Impact Tunneling with REAM, Impact methods would appear to be more practical at this point. Besides, high energy impact is basically a more practical way of delivering repeated "shots" with a steel "projectile".

Finally, Table 2 shows a compilation of all recently reported impact excavation devices. Clearly, experience is being developed over a broad spectrum of blow energies, and the next few years could well see the emergence of this new excavation technology.

---

\*We recognize the specific energy criterion has many flaws in it. A more meaningful measure may be \$/ton. However, realistic cost figures are difficult to derive, hence the specific energy basis is commonly used.

+ see Ref. 5 thru 8.

### III MAJOR ACCOMPLISHMENTS

#### FIELD TEST OF IMP-1000

##### A. Background:

Developed at Impulse Products, IMP-1000 is an experimental medium range impactor. Only two such units have been built. Plate 1 shows the physical unit mounted on a Unihoe #117. This type of device is called a hurled bit impactor because the piston and the tool point attached to it are hurled against the rock face. This contrasts with struck-bit device in which the piston strikes a separate tool point which in turn strikes the rock. Since metal-to-metal impact is avoided in hurled bit type units, they are usually more compact for the energy delivered than the struck-bit unit.

The IMP-1000 is a gas charged (nitrogen gas) hydraulically actuated unit. Figure 1 shows the valves used to operate the impactor. After the operator presses the switch on the actuator valve, it takes roughly 4 to 5 seconds to charge the tool. After charging, the tool automatically fires. Upon firing, the operator releases the switch for 4 to 5 seconds to drain the fluid. After that the cycle can be started over again.

##### B. Adapting the tool to the mounting

Early in 1973 an IMP-1000 unit and a valve system (plate 2) was purchased from Impulse Products, San Diego, California. Suitable mounting bracket was fabricated and the tool was attached to the Unihoe. To protect the operator from rocks flying off the face, a plexiglas plate was mounted in front of the operator; later, during the tests, the plate proved to be a wise safety measure.

##### C. Calibration

The blow energy delivered by the tool is a function of the charge pressure. Little data were available on actual energies obtained as a function of charge pressure. Therefore, the tool was calibrated using a Scan-Matic optical probe to measure impact velocity of the tool point at impact.

Velocities were measured at 600 psi and at 800 psi of charge pressure, and from the measured velocities, the blow energies were determined\* to be 6700 ft. lbs. and 10,600 ft. lbs., respectively, at the two charge pressures.

During a further calibration test at 1000 psi charge pressure the probe sheared away. Since it was not planned to run tests at 1000 psi charge pressure (the tool was judged to be too weak to sustain multiple blows at that level) further calibration effort was discontinued.

#### D. Field Test #1:

At this point in time, the back hoe was shipped to Ingersoll Rand Quarry in Martins' Creek, Pennsylvania. There, a suitable solid face had been previously selected for the IMP-1000 tests. Plates 3-a and 3-b show the face.

In running the field tests, the objective was to determine the effect of blow energy, blow spacing and tool geometry on the specific energy of excavation. To facilitate the test, an area roughly 40" x 40" was selected. Using spray paint, spots were marked at 6", 9" and 12" spacings to allow the operator to position the impactor at the proper spacing. (see plates 4-a and 4-b)

#### Preliminary Trials:

It was observed very early, that delivering more blows in one spot before indexing results in production of much more rock than repeated traverse with the same number of blows. This is probably due to the fact that during repeated traversing, the spot at which a blow was delivered during the earlier traverse, cannot be located accurately enough and thus the tool hits unbroken rock, losing effectiveness.

---

$$*E_b = \frac{1}{2} \frac{wv^2}{g}$$

w=tool point weight  
v=velocity

On the other hand, when multiple blows are delivered in the same spot before moving tool over to the next spot (Indexing), the first blow creates cracks and subsequent blows effectively propagate these cracks further. Thus the multiple blow technique is more effective. Without digressing further, it would suffice to say that all further testing was done with three consecutive blows in each spot.

The first test series was run with tool charged to 800 psi. A blunt-tool point (plate 5) was used to avoid damage due to glancing blows early in the test program. Tests were run with 6", 9", and 12" spacings. Table 3 shows the results.

Since the results were encouraging, and the tool showed no sign of damage, it was decided to try a pointed tool\*. The flat and pointed tools are shown in plate 6. The first test with the pointed tool was run at 12" spacing. At that spacing the pointed tool showed, as one would expect, considerable improvement over the flat tool. The progress of excavation is shown in plates 7, and 8. After that, a test was run at 9" spacings. During the latter part of the test, the tool acted quite sluggishly. The operator noted that the full energy was not being delivered. However, the testing was continued since no observable damage was found.

In the middle of the next test, at 6" spacing, the impactor seized, and would not retract. At that point the tool was brought back to the laboratory and dismantled. It was observed that the Guide Tube had bent as shown in plate 9. The results of the 9" and 12" spacing with pointed tool tests are also given in Table 3.

Figure 2 shows graphically the comparison between the blunt and pointed tools. One can see from the figure that the optimum spacing for a pointed tool at 800 psi charge (10,600 ft. lbs./blow) appears to be larger than 12" and with a low point, perhaps, of the order of 2,000 psi specific energy. The optimum point for the blunt tool tip is at approximately 12" spacing with a minimum specific energy of 4300 psi.++

---

\*Mr. H. Unger, the project technical officer, visited the test site during that series of tests.

++The optimum spacing is discussed further on p. 14.

Another problem experienced with the Impactor was that during the rapid acceleration of the tool, the actuator developed a vacuum behind the tool point. Rock dust was then sucked into the evacuated space, and powdered rock would pack on the top side of the point, causing sluggishness. It was decided to drill a small hole in the guide tube during subsequent testing to avoid developing a vacuum.

During the test with a 800 psi charge and a flat tool tip configuration, some time was spent in delivering blows using operator judgement (i.e. instead of a predetermined geometric pattern). It appeared that more rock was broken but the time to position the tool was 3 to 4 times longer than that with the fixed pattern of indexing.

#### E. Field Test #2:

A replacement for the bent tube was purchased from Impulse Products. The IMP was cleaned and reassembled. Now, the testing was started at 600 psi charge (blow energy of 6700 ft. lbs.). Data were gathered for blow spacings of 6", 9", and 12". These data are also included in Table 3. The results show that the optimum value of blow spacing is approximately 9", and at that spacing the specific energy is 2500 psi. Progress of excavation is shown in plates 10, 11, and 12.

Now the tests at the remaining test point, 6" spacing and 800 psi charge pressure were conducted to complete the field test as planned. Toward the end of this test, the impactor again became sluggish and some evidence of guide tube bending was observed. However, by now all tests according to the original plan had been conducted using the IMP tool.

#### F. Field Test #3:

At this point, it was decided to compare the results obtained with the IMP-1000 with some standard tool of much lower blow energy. For this purpose a Goblin-1100 tool supplies by Ingersoll Rand Rock Drill Division\* was used and breakage tests at 6", 9" and 12" spacings were performed. Goblin delivered approximately 1200 ft. lbs./blow and 44 bpm on the back hoe hydraulic system. These results, shown in table 3, gave a good coverage of a range of blow energies. The specific energy in these tests did not vary much with blow spacing; at 6-12" spacings the blow energies were around 7000-8000 psi.

#### G. Observations and Conclusions from the Field Tests

Figure 3 shows the effect of blow energy and blow spacing on the specific energy of rock breakage. Figure 4 is plotted using the optimum blow spacing at each blow energy. In figure 4 we also show published Russian data on underground excavations in granite (30,000 psi compressive) using their SO-AN-2 impact excavation unit. The curve for granite is drawn parallel to the data obtained during the present experimental program and passes at the lower end through data obtained from rock drill experience and through the SO-AN-2 data point.

\*see plate 13

### Optimum Blow Spacing

At a given blow energy the impacting tool produces in the impact zone some powdered rock and chipping, but more importantly it also produces sub-surface cracking. If a second blow is struck too close to the first blow, the tool impacts already damaged rock and fails to produce new subsurface cracking. At or near the optimum spacing, however, neighboring blows produce subsurface cracks which intersect and produce large chunks of broken rock. Thus, at spacings less than the optimum, the specific energy rises rapidly. If the blows are struck far apart, the subsurface cracks don't meet and the productivity of the tool decreases to the chipping volume (see e.g. Goblin results show that the volume of broken rock does not change significantly since all spacings are too large for the impact energy and, therefore, in all cases the production consisted only of the chipped away rock). Tools with higher blow energies and more pointed tips tend to produce larger subsurface cracks. Thus, the optimum spacing at 10000 ft. lb. blow energy is larger than that at 6700 ft. lbs. and so is the spacing larger for a pointed tool than for a blunt tool.

From a practical point of view, it is desirable to have large spacings between blows so that the time wasted in repositioning the tool can be minimized.

1. There is an optimum blow spacing for a given blow energy. It would be of great value to determine how the optimum spacing depends upon rock properties.
2. It can be seen that at the optimum blow spacing, the specific energy of rock breakage can be reduced and hence the efficiency of breakage can be substantially increased by increasing blow energy. Figure 4 indicates that at the same blow energy, the softer rock has lower specific energy than the harder rock.
3. Side loads produced by glancing blows produce severe loads on the impact tool. IMP did not withstand these loads.

4. A pointed tool was better than a flat tool and produced what seemed to be less dust than the latter. Both points appeared to produce less dust than other conventional rock breakage schemes.
5. To take advantage of the rock pattern the tool must be articulated properly against the rock face which was found to be difficult with the Unihoe boom.
6. Multiple blows delivered at a single spot seem to be more effective than multiple traversing of the blow pattern.
7. Blow energies over 20,000 ft. lbs. will reduce fracture energies below 1,000 psi level for rock of similar strength as our quarry. (see figure 4)
8. The operator was given a chance during a separate test at 800 psi charge pressure, to use his intelligence in delivering blows instead of using a predetermined pattern. It appeared that the amount of rock breakage per blow improved substantially but the time to position the impactor increased as well. The net effect on productivity in a tunneling situation remains to be determined.
9. During the entire test program we had no difficulty in cutting into the corners of the excavated area or, in other words, the tests proved curfing ability of the tool. No quantitative data was gathered on productivity during face cutting as contrasted with curf cutting.
10. All important test segments were recorded on movie film.

REPAIR OF DEMON - 300

During an earlier program (supported by ARPA under contract H 0210045) to determine the feasibility of impact excavation, two medium energy impactors Demon 100 and Demon 300 were used. These impactors broke down during the earlier field tests.

Plate 14 shows the Demon 300 impactor with cracks running along the welds on the guide rail and along the corners of the support box. This tool was loaned to the project by Ingersoll Rand Corp., with contractual obligation to return the tool to working condition. Therefore, the Demon 300 impactor was disassembled and the guide rails and the support box were rewelded. The tool was then reassembled to bring it to working condition.

### Rock Testing

In the recent Contract Modification No. 3 (January 9, 1973), laboratory rock testing was given lower priority than the field demonstration of IMP-1000 and, therefore, only a small amount of resources (manpower and money) were devoted to laboratory experimentation. However, early in the program rather interesting experiments were conducted that gave a qualitative indication of what is called "benching" in rock breakage. The concept of benching and related experiments are described below:

The nature of primary and secondary fracture in rock due to impact indentation was known qualitatively<sup>9</sup> for some time. Quantitative relationships between the length of primary crack and blow energy and that between fragmentation volume and blow energy for edge fracture (secondary fracture) was derived experimentally in ref. 10. As one would expect, rock can be broken very easily near a free edge. The question naturally came up that whether a free edge can be produced continuously so that rock can be broken more effectively.

The continuous production of new edge is called "benching". Several schemes of breaking rock to produce benching were conceived earlier. Two of these basic schemes were selected then experiments were conducted to determine the feasibility of each.

#### UNIDIRECTIONAL BENCHING:

The scheme is shown schematically in Figure 5. In the experimental work, 18" Barre granite cubes were used. The top face was marked at 2" spacing grid (see plate 15-a) to determine where blows were to be delivered. Then using IRRI\* drop tower facility (described in ref. 10) blows were delivered to break the rock at the edge. Plate 15-b shows the breakage after first breakage. The rock was then advanced to the next position (3" spacing) and once again blows were delivered to break to the edge.

---

\*IRRI - Ingersoll Rand Research Incorporated

The same process was continued in 2" increments. Although no accurate quantitative data were obtained due to small sized rock samples, it was observed that at each spacing increment, more and more energy was required to cause breakage. Further, a generally sloping surface contour developed (see plates 15-c, 15-d) which removed the advantage of breaking into the free edge. This type of benching was judged to be impractical because it requires ever increasing blow energy to cause successive breakages.

#### BIDIRECTIONAL BENCHING:

The concept for this type of benching is described in Fig. 6. Here one takes advantage of primary cracking to remove "blocks" of rock off a free edge. Once again the rock face was marked for indexed blows at a spacing of 2". Now blows were delivered with just enough energy (111 ft. lbs.) to produce subsurface cracking but not full edge fracture. After indexing the top surface, the block was turned through 90°, and positioned under the tower at 4" from the free edge. Blows were delivered at approximately 400 ft. lbs. so that the cracks produced by these blows will meet cracks produced by blows delivered on the top surface. The experiments proved that it was indeed possible to produce cracks from two directions that can meet to "cut" a block of rock. Approximately 30 cu. in. of rock was broken per pair of blows from the two directions. The specific energy of breakage was 555 ft. lbs./30 cu. in. or 222 psi. Plates 16 and 17 show two such blocks cut by the process.

In conclusion: The specific energy of edge fracture was found to be quite low, and depends upon available blow energy and the blow distance from the edge. The bidirectional fragmentation process is a means of "intelligent" rock breakage and should be studied further. It has potential for various types of efficient excavation machines. One important question for study is whether the benching can be continued indefinitely as the breakage advances.

### Sizing a 50,000 ft. lb. impactor

The work done on sizing of an impactor capable of delivering 50,000 ft. lbs./blow has been reported in depth via the semi annual report on the project, TM7304, Ref. 11. A summary of the findings is given below.

It was estimated from earlier work that a 50,000 ft. lb./blow (named IRX-50) impactor will be needed to tunnel through hard rock. Existing impactor mechanisms were examined to find a suitable design for IRX-50. It was concluded that gas return type actuator was suitable for the application.

Impact velocity was selected to be 60 ft./sec. On the basis of that velocity, the hammer weight and recoil weight were determined. Gas charge volume was determined on the basis of past experience in designing impactors like IMP-1000. The layout of the impactor is shown in Figure 7. The overall dimensions of the tool are: length  $\approx 10'$ , diameters  $\approx 2'$ , and weight  $\approx 10,000$  lbs.

The following areas were judged to be of critical importance in the final design of the tunneling system:

1. Side load absorbtion system: It can be seen from the experience with IMP-1000 and in the past with Demon 300 that side-loads are of critical importance. A suitable load absorbtion system must be laid out, designed, and tested in a future program.
2. Boom design: Manuverability of the tool is also equally important. Several degrees of freedom of the boom movement are necessary to orient the tool properly with respect to the rock face.

The following areas were judged to be important (but less critical than those above) and should be given attention during detailed design effort:

1. Seals and Bearings: These must not only prevent leakage of oil and gas but also keep the rock dust from penetrating into the impactor system.
2. Recoil Containment: Recoil must be contained properly so that at least a part of the recoil energy can be recovered.
3. Tool point attachment: One must be able to change the tool point quickly in the field and yet it must, at the same time, be strong enough to sustain impact loads.

The conclusion of the tool sizing study was that, it was feasible and practical to design and build a tool capable of delivering 50,000 ft. lbs./blow. Further, such a tool can be mounted on presently available mountings e.g. coal miner crawler frame. The study isolated the problem areas, stated above, which require special attention during design and development of the tunneler using a 50,000 ft. lbs./blow impactor.

#### IV Conclusions and Recommendations for Future Work

From a total evaluation of the work done during both the first year (previous contract no. H 0210045) and the second year (current project contract no. H 0230006) on High Energy Impact Excavation, one arrives at the following conclusions:

1. Increase in blow energy results in increased efficiency of rock excavation.
2. To obtain the same specific energy of breakage, larger blow energies are needed in harder rocks than softer rocks.
3. There usually exists an optimum spacing at a given blow energy in a given rock such that the specific energy is lowest at that point. This experience is similar to fixed pick rock cutting experiments conducted by Barker<sup>12</sup> and probably for the similar reasons.
4. During the testing it was observed that most of the pieces of rock broken out are large compared to drilling and rock cutting using pick-type cutters. Coarser pieces of rock mean less amount of dust produced for a given amount of rock broken out. The amount of dust produced by IMP-1000 was qualitatively judged to be small. This is a distinct advantage of the impact unit.
5. Experimental work done with IMP-1000, the sizing study on a 50,000 ft. lb./blow impactor and the published data from Russian experiments clearly show that it is quite feasible to develop a high energy impact tunneling system.

A proof of the concept, therefore, should be obtained as soon as possible, by designing, building, and "in-situ" testing such as a tunneling system.

6. Rock testing indicated an interesting mode of rock breakage. This intelligent breakage technique, namely bidirectional benching, should be studied further.
7. Side loads produced by glancing blows turned out to be a persistent problem. Care should be exercised in designing the future impactors to withstand side loads.
8. Repeated blows in a single place before indexing yield more rock than repeated surface coverage using single blows. The optimum number of blows in a single spot and its relationship to blow energy and rock strength remains to be evaluated. Future work should include an effort directed to resolve this issue since it could have important implications in design of an effective boom and indexing scheme.
9. Articulated impact using the operator's judgment (intelligent excavation) seems to yield more rock than orderly spaced blows. This, however, needs to be proven systematically.

Further, any future work should resolve the following as to whether intelligent excavation scheme results in lower cost per ton rather than more rock per blow (the cost of time wasted in articulating the tool must be worth effective increase in rock breakage).

10. With IMP-1000 it was possible to cut into the corners of the excavated area, in other words the tool showed a kerfing ability. Any future effort should measure specific energy difference between face cutting and kerf cutting.

In all, by now, the take off point has been reached in developing an experimental high energy impact tunneling system. Active Government support is, therefore, urgently required.

REFERENCES

- 1.a. Voitsekhovskiy, B.V. "Advertising and Technical Description of SO-AN-2 Entry Driving Machine".
- 1.b. U. S. Patent No. 3,605,916. by Voitsekhovskiy
2. Morris, A. H. and Rodford, I. G. "Development of Impact Ripping". Colliery Guardian (Aug 1972) pp. 399-405
3. Morris, A. H. , Moore, K., and Rodford, I. G. "Impact Ripping-A survey of Experience to Date". Presented at Institute of Mining Eng., So. Midland Branch, England. (Dec. 1972)
4. Du Toit, P.J.G. "Mechanical Rock Pick". Mining Congress Journal (April 1973) pp. 60-63.
5. Watson, J.D. "Semi-Annual Status Report of the REAM". PITR-391, ARPA Contract No. H0220015. (Aug. 1972).
6. Singh, M.M. "Novel Methods of Rock Breakage". Proceedings of the II Symp. on Rapid Excavation (Oct. 1969).
7. Schumacher, B.W. "An Electron Beam Gun for Hard Rock Excavation Test". Mining Congress Journal (June 1972) pp. 36-42
8. Bailey, J. J. and Dean, R. C., Jr., Rock Mechanics and the Evolution of Improved Rock Cutting Methods, Proc. Eighth Symp. Rock Mech., AIME, New York, 1967, p. 396-409.
9. Paul, B. and Gangal, M. "Why Compressive Loads on Drill Bits Produce Tensile Splitting in Rock". Paper No. SPE 2392 (1969)
10. Hollenberg, J., Yaros, L. and Gangal, M. "High Energy Impact Rock Breakage Research Program". Annual Report on ARPA Contract No. H0210045 (march 1972).
11. Gangal, M. "Research Program on the Design of an Experimental High Energy Impact Tunneler". Semi-annual Report, TM-7304, ARPA Contract No. H0230006 (March 1973)
12. Barker, T.S. "A Laboratory Investigation of Rock Cutting Using Large Picks". Int. J. Rock Mech. Mining Sci. (1964) Vol. 1, pp. 519-534.

TABLE 1  
COMPARATIVE SPECIFIC FRACTURE ENERGIES  
FOR VARIOUS TECHNIQUES

A. Reference Concepts	<u>(Specific Fracture Energy) *</u> Compressive Strength
1. Drill, Blast and Muck	3.5
2. Boring Machine	0.5
3. Impact Tunneling (USSR Tests)	0.095
4. Manual - i.e. intelligent - rock Excavation	0.046
B. Thermal	
1. Flame Jet	110.
2. Lasers	1.8
3. Electron Beam	0.7
4. Subterrene - nuclear heating	0.5
C. Water	
1. Cavitation	10,000.00
2. Erosion	1,000.00
3. Steady Jet	30.00
4. Water Jet with Disc Cutters	5.00
5. Pulsed Jet - 'Water Cannon'	0.5
D. Projectiles	
1. Air Gun Firing Plastic Pellets	0.5
2. Air Gun Firing Steel Balls	0.14
3. Conventional Gun Firing a Concrete Projectile (REAM)	0.052

\* Note: Published technical literature, from which the above listing was derived, includes a broad range of performance values for many of the techniques listed. In selecting values for this table the objective was to show a single representative value. A survey of past research reports will in most cases reveal both higher and lower values than those indicated here.

DETAILS OF PROPRIETARY IMPACT UNITS

TABLE 2

Manufacturer	Type	Approx Max Blow Energy	Blows per Min	Weight Without Tool	Hydraulic Supply at 2000 psi Flow/Min	Status
Ingersoll-Rand	G500	500 ft. lbf.	135-600	485 lb.	Up to 21 gal Up to 36 gal	Commercial
	G1100	1400 ft. lbf.	60-600	748 lb.		
	Demon 100	3000	-			
	Demon 300	10000	-			
	IMP 1000	15000	-			
Krupp	HM 401*	400 ft. lbf.	550	882 lb.	13-15 gal 15-21 gal	Commercial
	HM 600	1350 ft. lbf.	450	992 lb.		
Shand	Fluicon	1650 ft. lbf.	160-180	1150 lb.	13 gal	Commercial
Montabert	BRH 500	1480 ft. lbf.	320-450	920 lb.	13-37 gal	Commercial
Gullick		3000 ft. lbf.	600	1550 lb.	40.5 gal	Commercial
Russian	SO-AN-2	72000 ft. lbf.	30			Prototype

\*Note: The Krupp HM 401 is now replaced by the HM 200.

Table 3  
Experimental Observations  
At Martins Creek Limestone Quarry

Test No.	Impact Tools	$E_b$	Point Type	No. of Blows	Inch Spacing	Wgt. of Rock lbs.	Spec. Ener. PSI
1	IMP1000	10600	Flat	150	6	214	8915
2	IMP1000	10600	Flat	75	9	196	4867
3	IMP1000	10600	Flat	100	12	305	4170
4	IMP1000	10600	Pointed	85	12	312	3465
5	IMP1000	10600	Pointed	100	9	197	6456
6	IMP1000	10600	Pointed	79	6	93	10805
7	IMP1000	6700	Pointed	81	6	154	4228
8	IMP1000	6700	Pointed	75	9	234	2576
9	IMP1000	6700	Pointed	48	12	121	3189
10	Goblin	1200	Moil	1176	6	235	7206
11	Goblin	1200	Moil	600	9	105	8228
12	Goblin	1200	Moil	384	12	75	7372

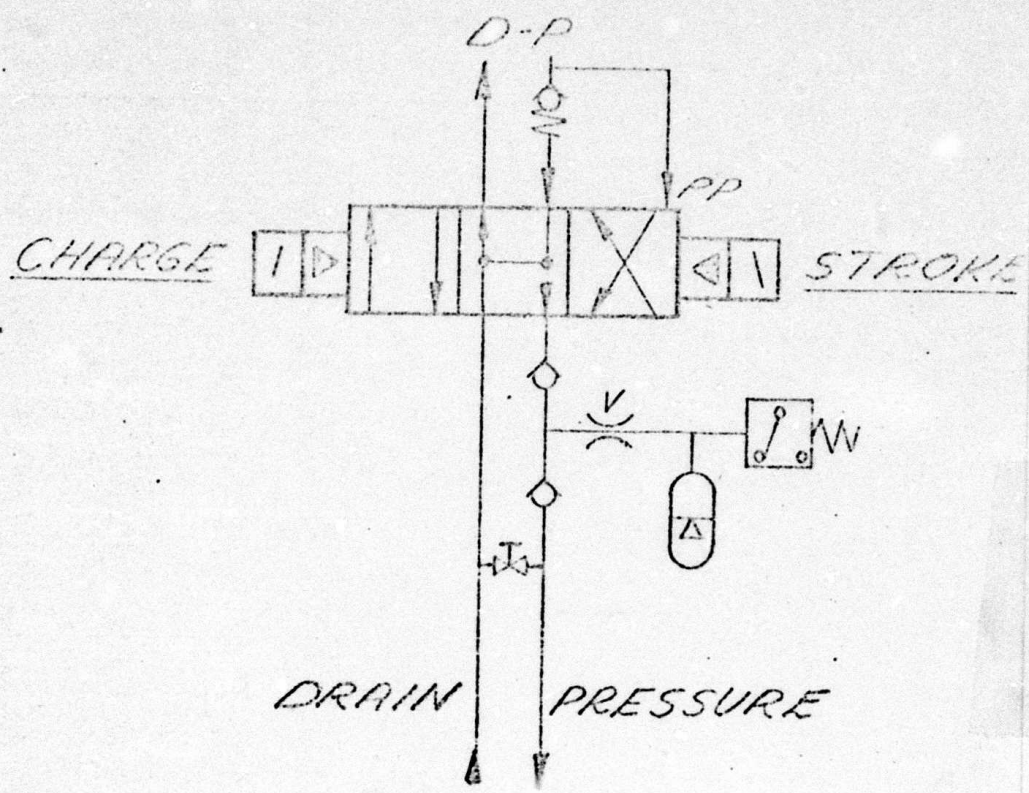

IMP-1000

Fig 1: Control Circuit

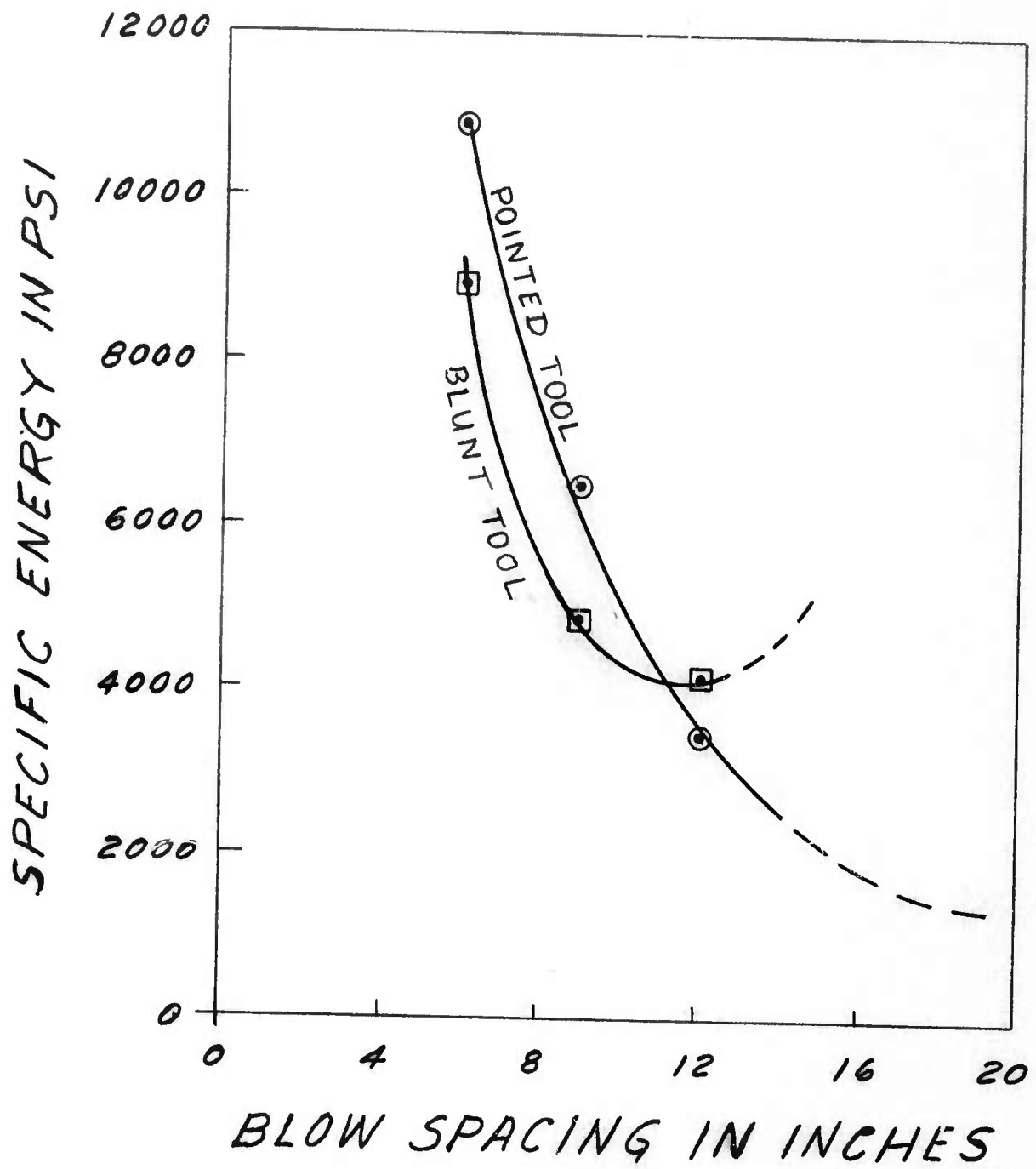

Fig 2: Effect of Tool Tip Geometry on Specific Energy and Blow Spacing

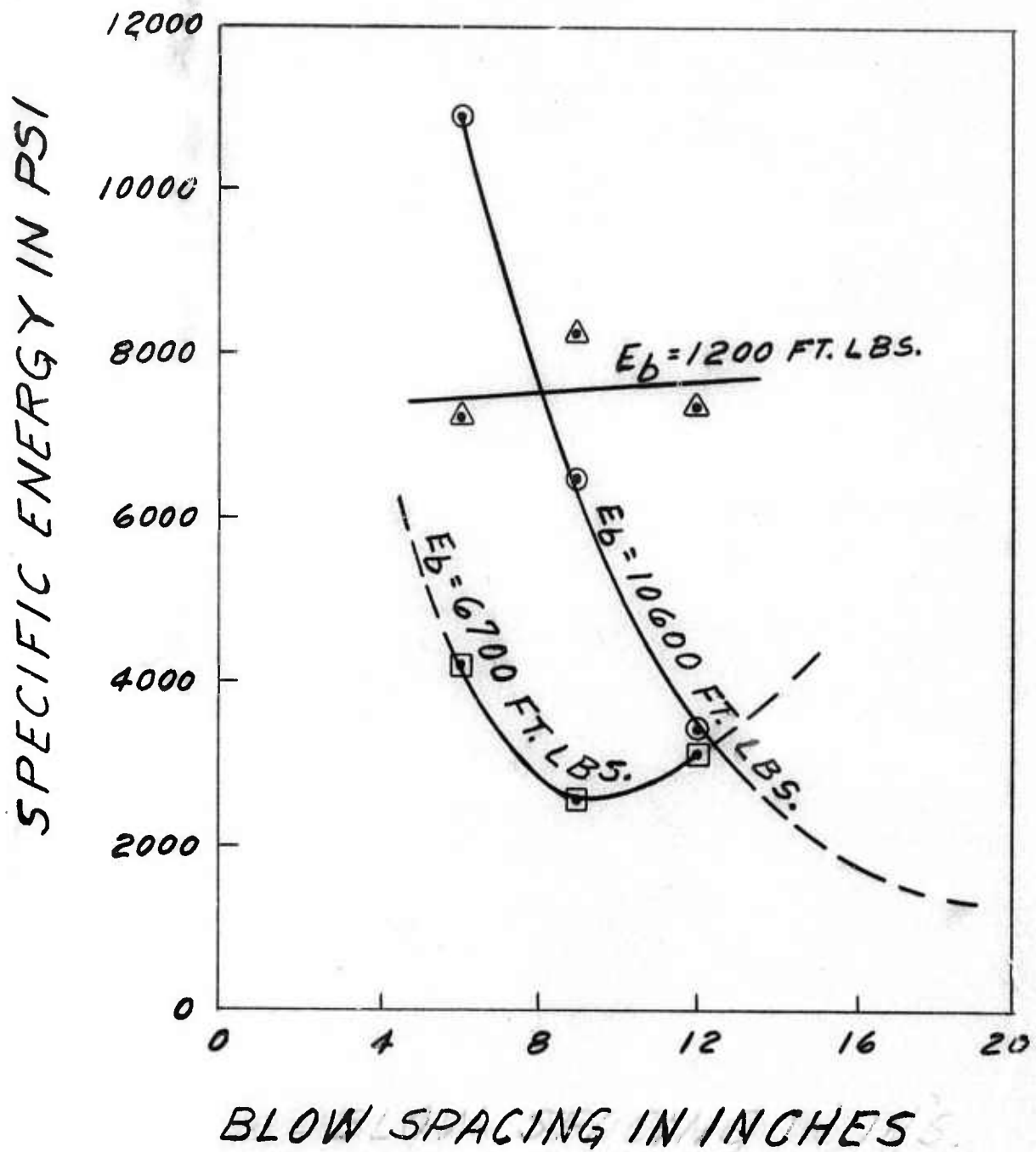
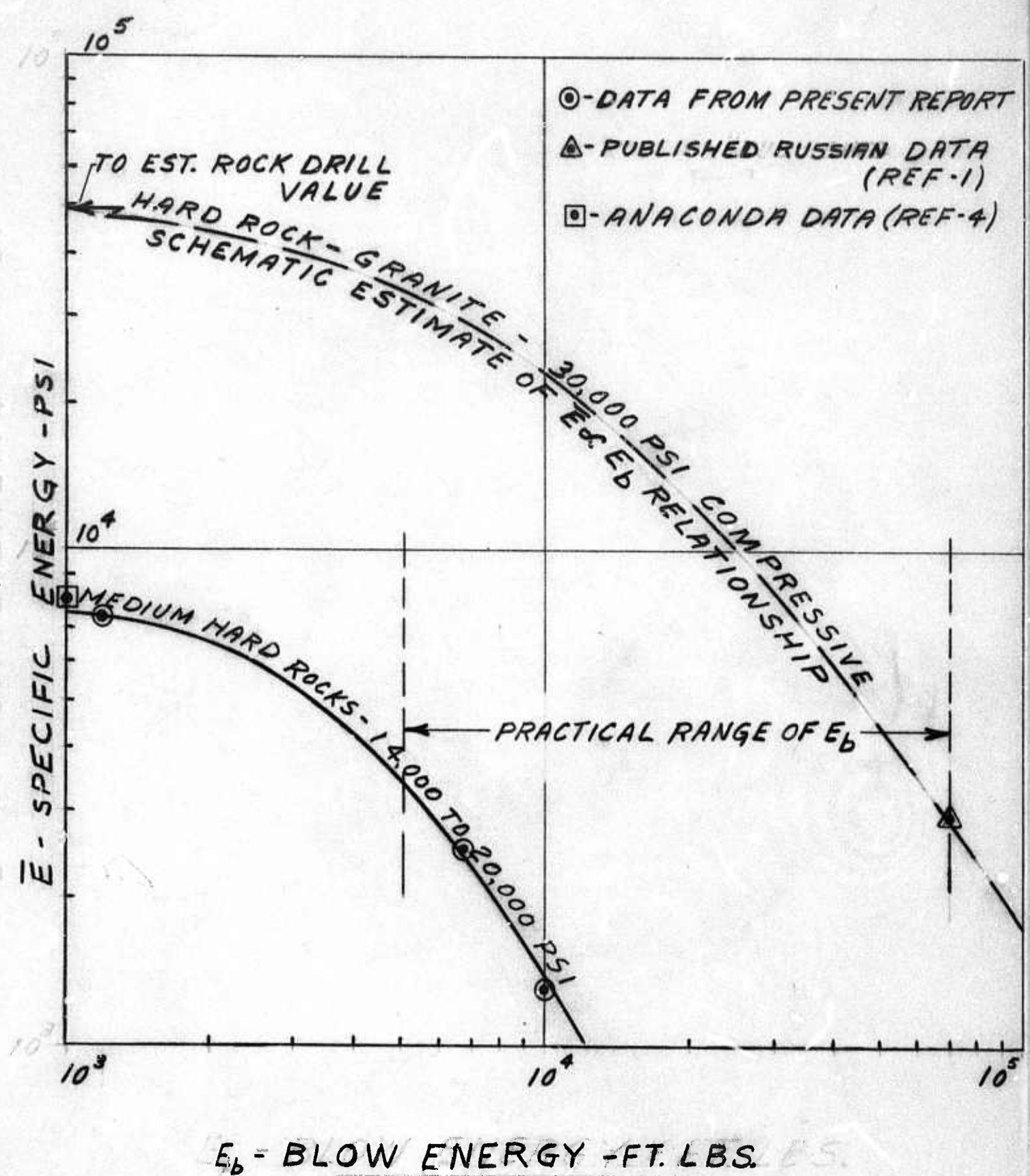

Fig 3: Effect of Blow Energy of Specific Energy and Blow Spacing



$E_b$  - BLOW ENERGY - FT. LBS.

Fig 4: Effect of Rock Strength on Tool Performance at Optimum Blow Spacing

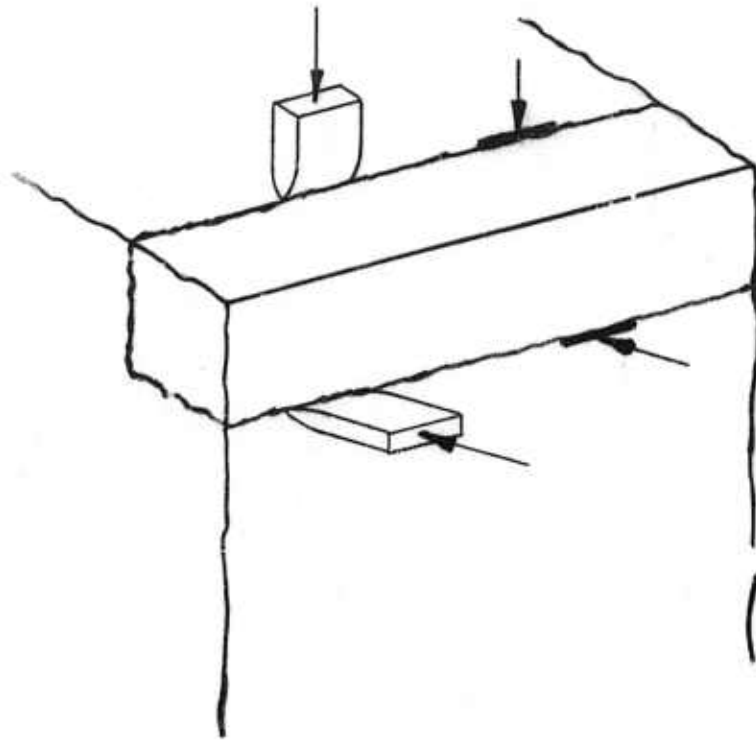
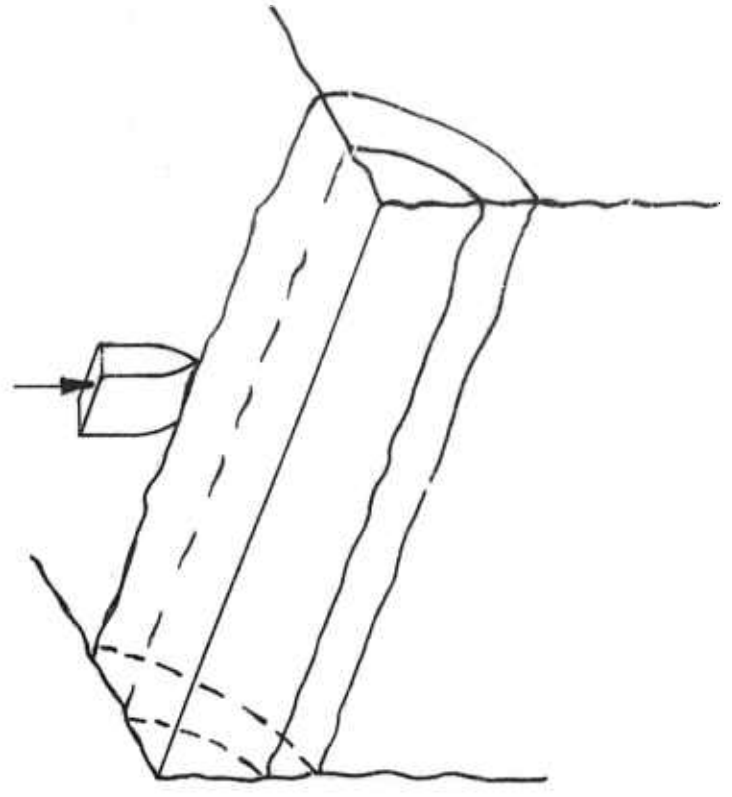
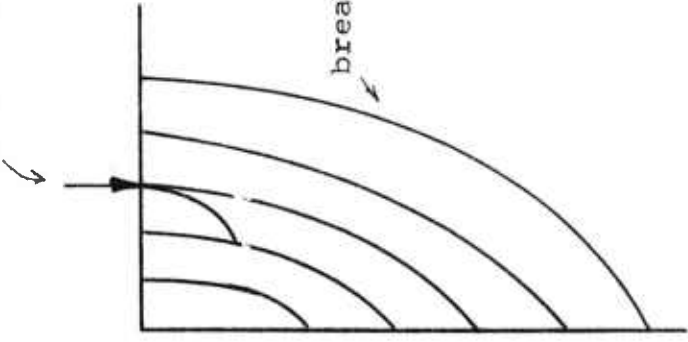

Fig 6: Bidirectional  
Benching



successive indentations



breakage pattern

Fig 5: Unidirectional benching

HOUSING ≈ 4,000 LBS.  
 BEAM MASS ≈ 5,000 LBS.  
 HEAD MASS ≈ 1,000 LBS.  
 TOTAL ≈ 10,000 LBS.  
 CHARGE VOL ≈ 750 CM<sup>3</sup>

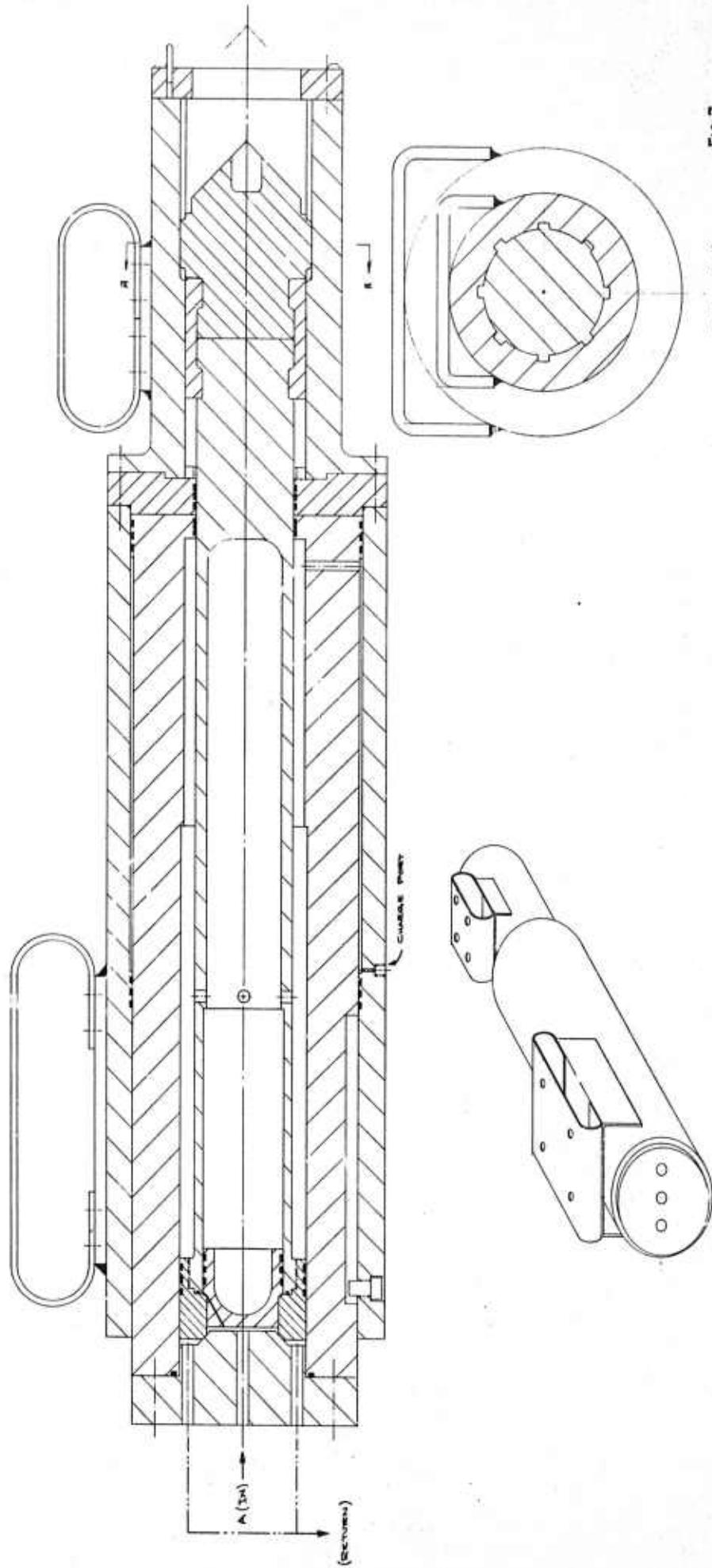

34  
 FIG. 7  
 HIGH ENERGY  
 IMPACT TOOL IFR-50  
 SMIN 3-6-73  
 BR-00-01-03

SEC A-A

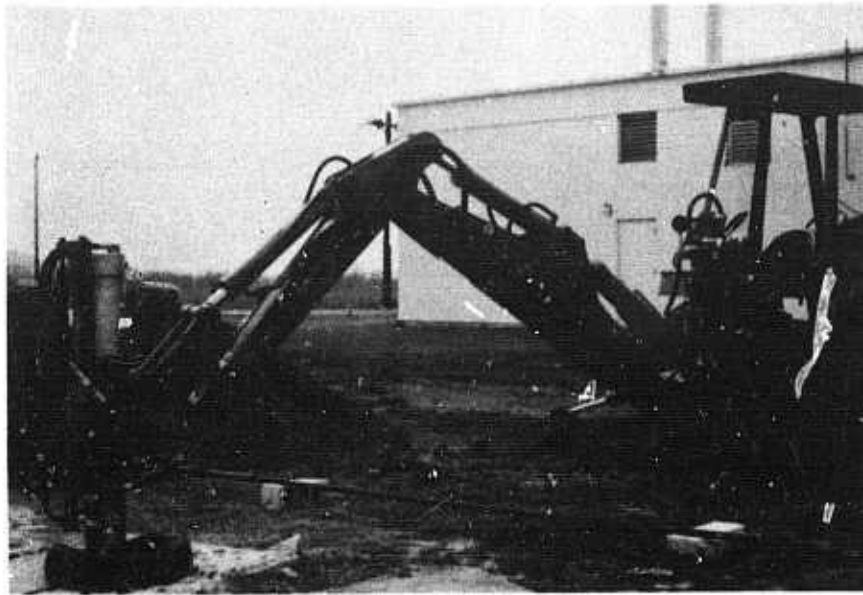

Plate 1  
IMP-1000 unit

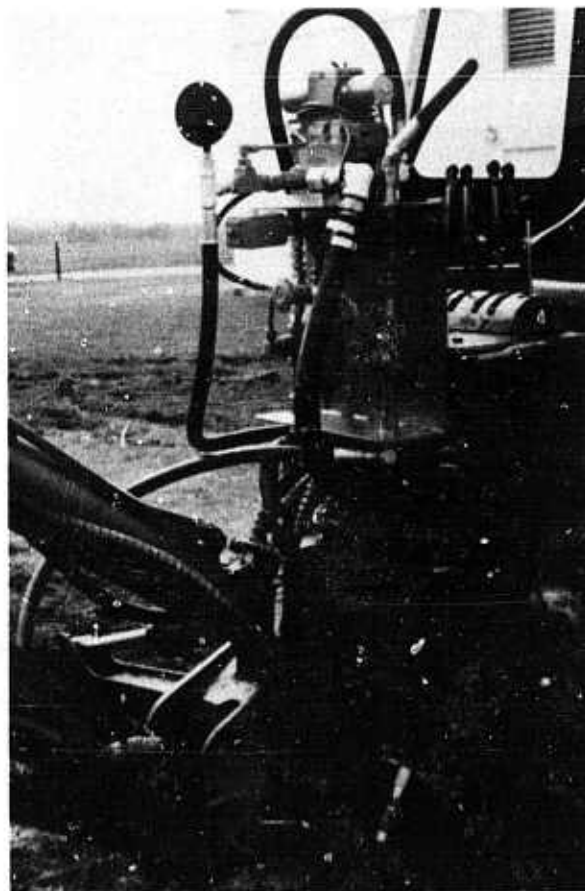

Plate 2  
Hydraulic Control  
Valve System



Plate 3-a  
Rock Face Chosen for Test



Plate 3-b  
Close-up of Test Area



Plate 4-a  
Start of the Test



Plate 4-b  
Marked up Test Area

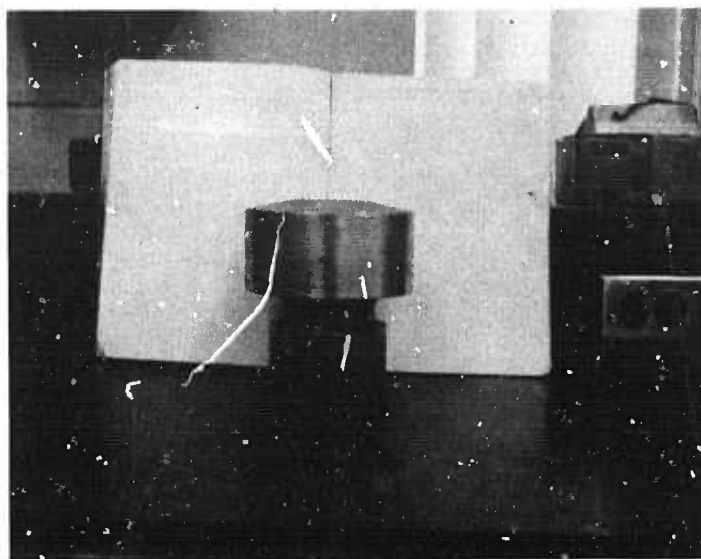

Plate 5  
Blunt Tool Tip



Plate 6  
Pointed Tool Tip



Plate 7  
Progress of Excavation



Plate 8  
Progress of Excavation  
(shows rock gathering  
system used in the tests)



Plate 9-a

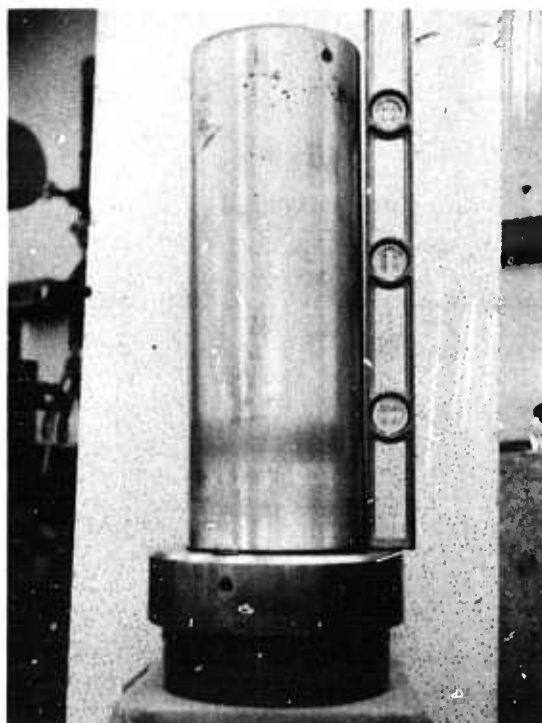

Plate 9-b

Plates 9: Bent Guide Tube



Plate 10-a

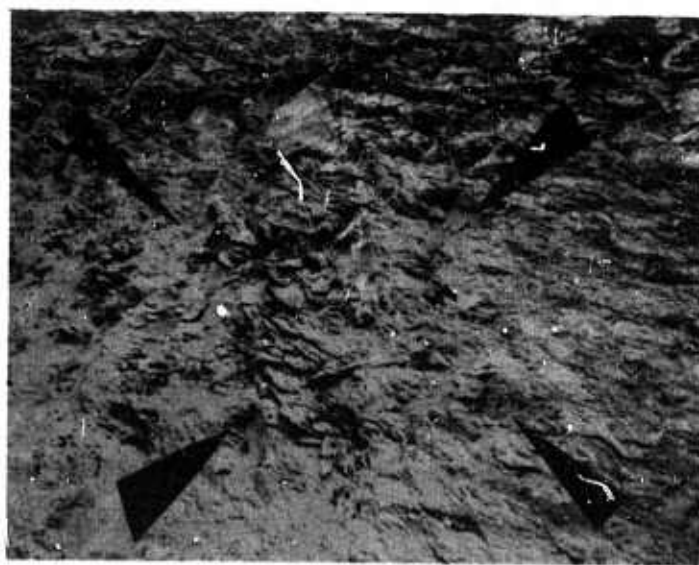

Plate 10-b

Plates 10: Progress  
of Excavation

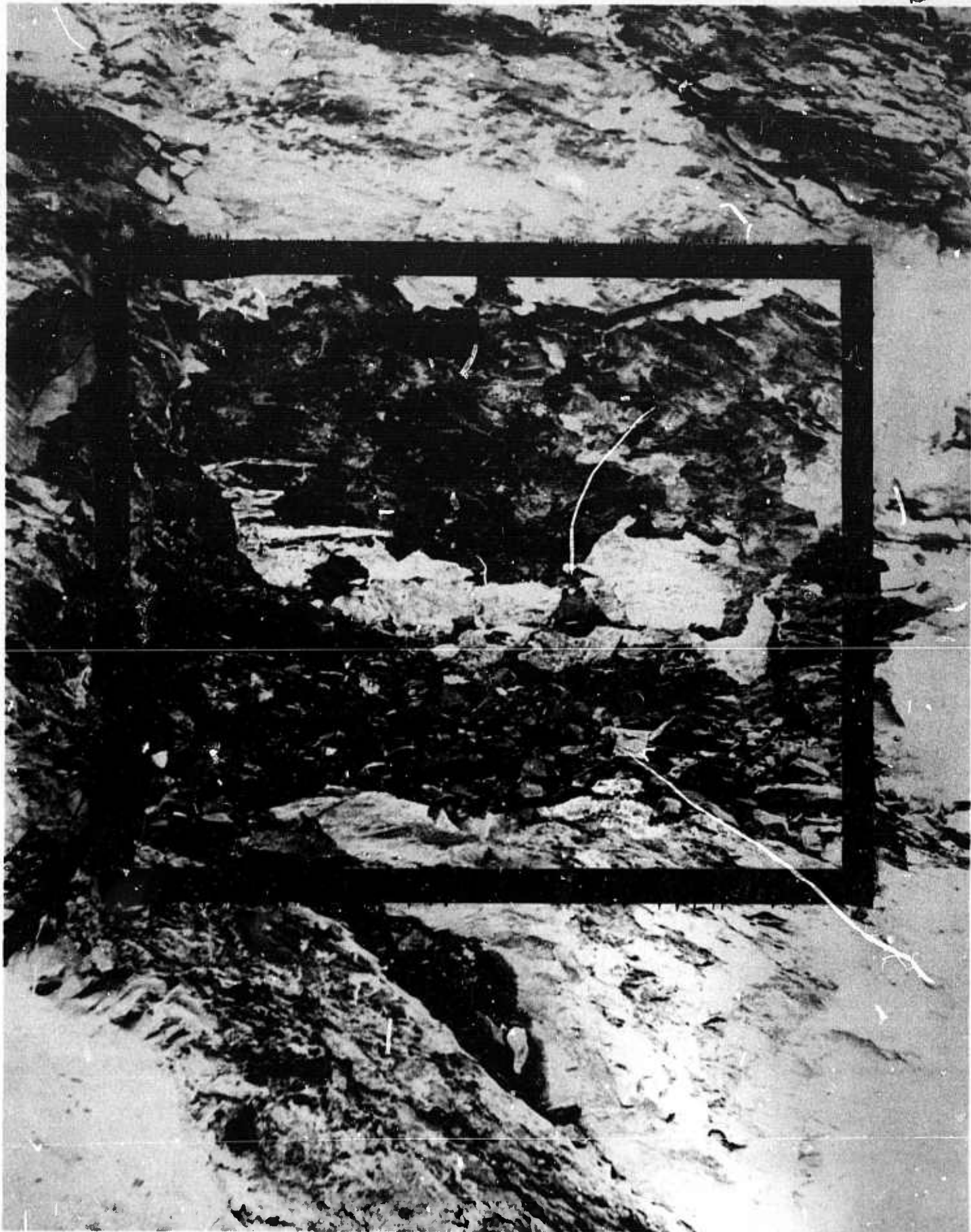

Plate 11

Progress of Excavation



Plate 12  
Progress of Excavation Close-  
up



Plate 13  
Goblin Mounted on Back-hoe

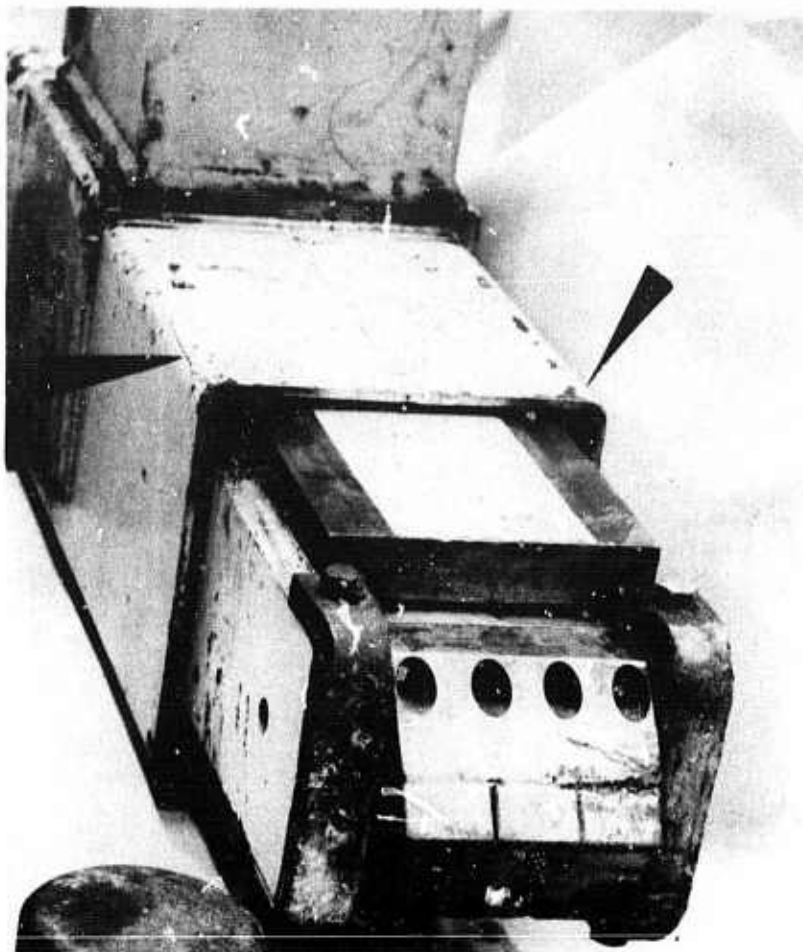

Plate 14-a

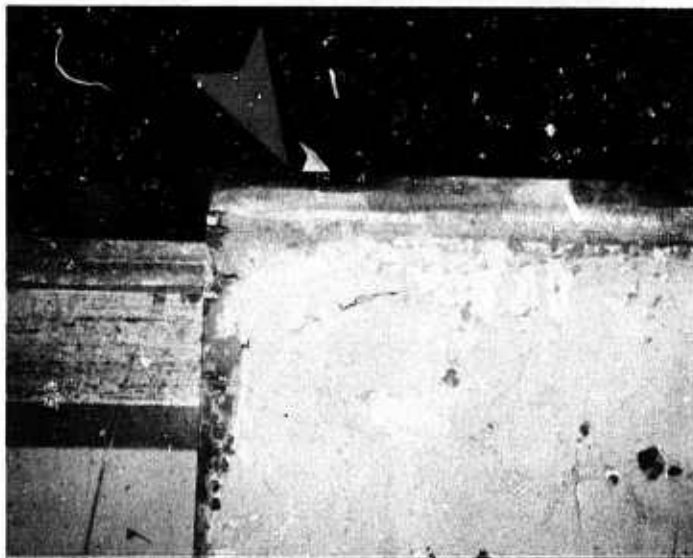

Plate 14-b

Plates 14: Cracks in  
Demon 300



Plate 15-a: Grid Pattern

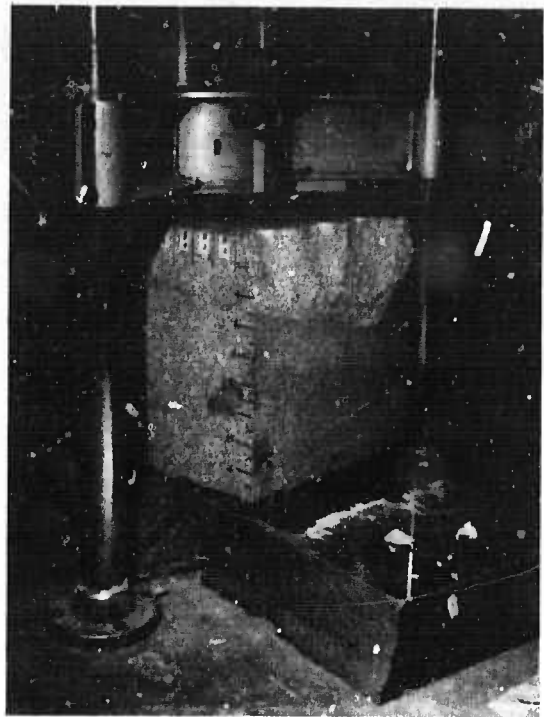

Plate 15-b: First Edge Cut



Plate 15-c: Second edge cut



Plate 15-d: Third edge cut



Plate 16: Experiment  
in Bidirectional Eencing

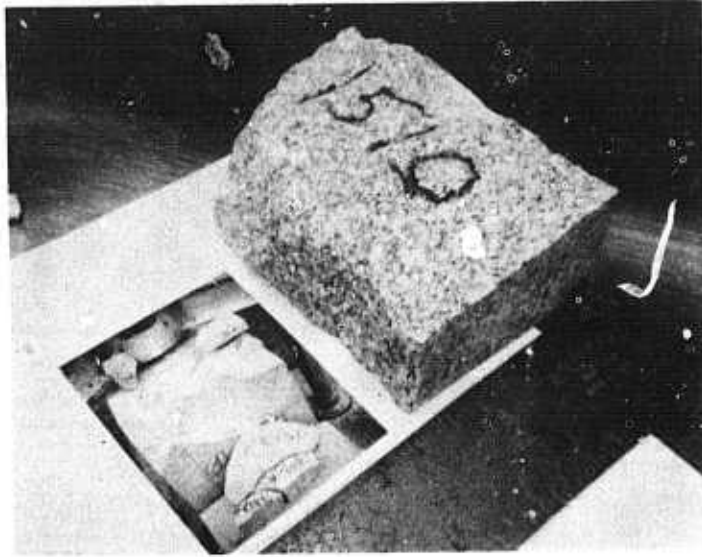

Plate 17-a

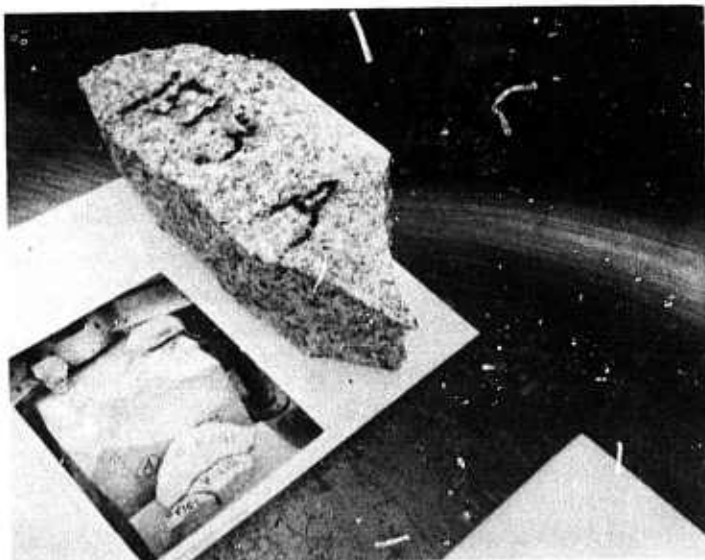

Plate 17-b:  
Clean Bidirectional Breakout