

AD-775 015

"THE HYPOLE" A VERTICALLY POLARIZED
HYBRID DIPOLE FOR APPLICATION IN LAND
MOBILE AND SHIPBOARD COMMUNICATIONS

Herbert Bramwell Shaw, III

Naval Postgraduate School
Monterey, California

December 1973

DISTRIBUTED BY:

NTIS

National Technical Information Service
U. S. DEPARTMENT OF COMMERCE
5285 Port Royal Road, Springfield Va. 22151

AD 775015

SECURITY CLASSIFICATION OF THIS PAGE (When Data Entered)

REPORT DOCUMENTATION PAGE

READ INSTRUCTIONS BEFORE COMPLETING FORM

1. REPORT NUMBER 2. GOVT ACCESSION NO. 3. RECIPIENT'S CATALOG NUMBER

4. TITLE (and Subtitle) "The Hypole" A Vertically Polarized Hybrid Dipole for Application in Land Mobile and Shipboard Communications 5. TYPE OF REPORT & PERIOD COVERED Master's Thesis; Dec 1973 6. PERFORMING ORG. REPORT NUMBER

7. AUTHOR(s) Herbert Bramwell Shaw, III 8. CONTRACT OR GRANT NUMBER(s)

9. PERFORMING ORGANIZATION NAME AND ADDRESS Naval Postgraduate School Monterey, California 93940 10. PROGRAM ELEMENT, PROJECT, TASK AREA & WORK UNIT NUMBERS

11. CONTROLLING OFFICE NAME AND ADDRESS Naval Postgraduate School Monterey, California 93940 12. REPORT DATE December 1973

13. NUMBER OF PAGES 60

14. MONITORING AGENCY NAME & ADDRESS (if different from Controlling Office) Naval Postgraduate School Monterey, California 93940 15. SECURITY CLASS. (of this report) 16a. DECLASSIFICATION/DOWNGRADING SCHEDULE

16. DISTRIBUTION STATEMENT (of this Report) Approved for public release; distribution unlimited.

17. DISTRIBUTION STATEMENT (of the abstract entered in Block 20, if different from Report)

18. SUPPLEMENTARY NOTES NATIONAL TECHNICAL INFORMATION SERVICE U.S. Department of Commerce Springfield, VA 22151

19. KEY WORDS (Continue on reverse side if necessary and identify by block number) Antennas, Mobile Antennas, Monopole Antennas, Vertical Antennas, Whip Antennas, VHF Antennas

20. ABSTRACT (Continue on reverse side if necessary and identify by block number) This is a study of a unique feed system which was developed to improve the performance of typical Half-Wave vertical mobile communications antennas. Popular misconceptions concerning the absolute gain of such radiators are discussed. Since vehicular roof-sized ground planes limit the realizable gain of currently used Half-Wave whips, the goal selected was to decouple the

radiator from these undersized ground planes. "The Hypole" antenna which evolved is demonstrated to have adjustable input impedance which is easily matched, true Half-Wave Dipole performance, and minimum gain and pattern degradation.

"THE HYPOLE" A VERTICALLY POLARIZED HYBRID DIPOLE FOR
APPLICATION IN LAND MOBILE AND SHIPBOARD COMMUNICATIONS.

by

Herbert B. Shaw, III

Lieutenant, United States Navy

SUBMITTED IN PARTIAL FULFILLMENT OF THE
REQUIREMENTS FOR THE DEGREE OF

MASTER OF SCIENCE IN ELECTRICAL ENGINEERING

FROM THE

NAVAL POSTGRADUATE SCHOOL

December 1973

AUTHOR

Herbert Bramwell Shaw III

APPROVED BY:

Richard W. Adl

THESIS ADVISOR

Sydney R. Parker

CHAIRMAN, DEPARTMENT OF ELECTRICAL ENGINEERING

Milton H. Coates

ACADEMIC DEAN

ABSTRACT

THIS IS A STUDY OF A UNIQUE FEED SYSTEM WHICH WAS DEVELOPED TO IMPROVE THE PERFORMANCE OF TYPICAL HALF-WAVE VERTICAL MOBILE COMMUNICATIONS ANTENNAS. POPULAR MISCONCEPTIONS CONCERNING THE ABSOLUTE GAIN OF SUCH RADIATORS ARE DISCUSSED. SINCE VEHICULAR ROOF-SIZED GROUND PLANES LIMIT THE REALIZABLE GAIN OF CURRENTLY USED HALF-WAVE WHIPS, THE GOAL SELECTED WAS TO DECOUPLE THE RADIATOR FROM THESE UNDERSIZED GROUND PLANES. "THE HYPGLE" ANTENNA WHICH EVOLVED IS DEMONSTRATED TO HAVE ADJUSTABLE INPUT IMPEDANCE WHICH IS EASILY MATCHED, TRUE HALF-WAVE CIRCULAR PERFORMANCE, AND MINIMUM GAIN AND PATTERN DEGRADATION.

TABLE OF CONTENTS

| | |
|---|----|
| I. INTRODUCTION----- | 4 |
| II. THEORETICAL CONSIDERATIONS----- | 7 |
| III. DEVELOPMENT OF ANTENNA CONFIGURATION----- | 15 |
| A. THE BALANCED FEED HYBRID DIPOLE----- | 15 |
| B. IMPEDANCE MEASUREMENTS AND RADIATION PATTERNS--- | 17 |
| C. DEVELOPMENT OF THE UNBALANCED HYBRID DIPOLE---- | 18 |
| IV. EXPERIMENTAL DEVELOPMENT----- | 23 |
| A. EFFECT OF A FINITE GROUND PLANE ON THE UNBALANCED HYBRID DIPOLE----- | 29 |
| B. ANTENNA PATTERNS----- | 35 |
| V. CONCLUSION AND RECOMMENDATIONS----- | 47 |
| APPENDIX A PRACTICAL CONSTRUCTION DETAILS FOR BUILDING HYBRID DIPOLES----- | 50 |
| LIST OF REFERENCES----- | 56 |
| INITIAL DISTRIBUTION LIST----- | 57 |
| FORM DD 1473----- | 59 |

I. INTRODUCTION

WHEN RADIO FREQUENCY ENERGY IS FED TO AN ANTENNA ONE OF THREE THINGS OCCUR: 1) THE ENERGY IS RADIATED AS ELECTROMAGNETIC WAVES, 2) IT IS REFLECTED BACK TOWARD THE GENERATING SOURCE, 3) IT IS DISSIPATED AS HEAT DUE TO OHMIC LOSSES IN THE ANTENNA. THE LAST TWO EVENTS ARE UNDESIRABLE AS THIS ENERGY IS NOT RADIATED, AND REFLECTED ENERGY CAN CAUSE PROBLEMS AT THE GENERATING SOURCE. EVEN WHEN MOST OF THE DELIVERED ENERGY IS RADIATED BY THE ANTENNA, THE SPATIAL ORIENTATION OF WHERE IT IS RADIATED IS VERY IMPORTANT. THE RADIATION ANGLE OF THE MAIN LOBE OF RADIATION SIGNIFICANTLY AFFECTS THE PERFORMANCE OF A MOBILE COMMUNICATION SYSTEM.

AS A CASE IN POINT TAKE VERTICAL MONOPLES MOUNTED ON THE ROOF OF A CAR OR ON A SHIP. HOW DO THESE ANTENNAS PERFORM? AT BEST, THEY ARE EQUIVALENT TO ONE HALF WAVELENGTH DIPOLES, THE THEORETICAL DEVELOPMENT OF WHICH CAN BE FOUND IN ALMOST ANY BASIC ANTENNA TEXT. THIS LEVEL OF PERFORMANCE IS ADEQUATE AND THE RADIATION PATTERN OF A VERTICALLY POLARIZED DIPOLE IS A GOOD COMPROMISE FOR A MOBILE PLATFORM, SINCE ITS LOCATION IN RESPECT TO OTHER STATIONS IS USUALLY UNKNOWN OR AT LEAST UNPREDICTABLE. HOWEVER, THE OBSERVED

PERFORMANCE OF THESE ANTENNAS IS FAR BELOW THAT EXPERIENCED WHEN USING A DIPOLE FROM THE SAME LOCATION. PATTERNS TAKEN ON MARITIME ANTENNA RANGES REVEAL THAT SHIPBOARD VERTICAL MONOPOLE ANTENNAS FREQUENTLY HAVE -2 DB GAIN IN RESPECT TO A REFERENCE DIPOLE.(1) THIS IS DUE TO THE EFFECTS OF THE SHIP'S HULL AND SUPERSTRUCTURE. MEASUREMENTS TAKEN ON SIMULATED VEHICLES ROOFS HAVE REVEALED THAT VERTICAL MONOPOLES IN THIS APPLICATION AGAIN ARE CONSISTENTLY -5 TO -10 DB WHEN REFERENCED TO A DIPOLE ANTENNA.(2)

THE PROBLEM UNDERTAKEN IN THIS THESIS IS TO DEVISE AN UNBALANCED FEED SYSTEM WHICH IS FLEXIBLE ENOUGH TO MATCH VARIOUS LENGTHS OF MONOPOLES AT VARIOUS HEIGHTS ABOVE A GROUND PLANE, AND TO USE THIS MATCHING SYSTEM WITH AN ANTENNA WHICH WILL PERFORM AS WELL AS A DIPOLE ANTENNA.

COMMERCIAL ANTENNA MANUFACTURERS CONTINUALLY INFER ONE QUARTER WAVELENGTH MOBILE ANTENNA "WHIPS" ARE EQUAL TO ONE HALF WAVELENGTH DIPOLES. AS SEEN FROM THE ABOVE MENTIONED MEASUREMENTS THIS IS FAR FROM THE TRUTH. ANTENNA GAIN FIGURES ARE FREQUENTLY GIVEN WHICH ARE STATED SO THAT THE CUSTOMER WILL THINK THIS IS THE CASE. IN MANY LAND MOBILE ADVERTISEMENTS GAIN FIGURES ARE FREQUENTLY GIVEN REFERENCED TO QUARTER-WAVE WHIPS. THE WRITTEN WORDS ARE TRUE, BUT THE REFERENCE ANTENNA CAN BE AS MUCH AS -10 DB WITH RESPECT TO A REFERENCE DIPOLE. AGAIN IT IS HOPEFUL THAT THE CUSTOMER WILL,

DUE TO PREVALENT "ANTENNA FOLKLORE", EQUATE THE WHIP TO THE HALF-WAVE DIPOLE. WHY DOES THIS HAPPEN? MAINLY BECAUSE IT HAS BEEN MATHEMATICALLY DERIVED THAT A QUARTER-WAVE MONOPOLE, IF PLACED ABOVE A FLAT, INFINITE, LOSSLESS GROUND IS EQUAL IN PERFORMANCE TO A HALF-WAVE DIPOLE IN FREE SPACE. (IN FACT THE GAIN CAN EVEN BE SHOWN TO BE 3 DB GREATER THAN THE DIPOLE DUE TO THE "PHILOSOPHICAL" RADIATION INTO "ONLY HALF-SPACE".) IT IS POSSIBLE TO MAXIMIZE THE FLATNESS AND MINIMIZE THE LOSS OF A GROUND PLANE, BUT HOW BIG IS "LARGE ENOUGH"? THIS HAS YET TO BE AGREED UPON. HOWEVER, ONE CAN BE CERTAIN THAT AT MOST FREQUENCIES COMMONLY USED FOR COMMUNICATIONS TODAY, "LARGE ENOUGH" IS GREATER IN EXTENT THAN A CAR OR TRUCK RCCF.

THERE ARE INHERENT LIMITATIONS IN THIS STUDY. THE INAVAILIBILITY OF A LARGE GROUND PLANE, AND THE INABILITY TO CREATE OTHER INTERFERING STRUCTURES THAT ARE SO COMMON ONBOARD SHIPS. THESE LIMITATIONS MAKE THIS STUDY APPLICABLE FOR USE IN CONJUNCTION WITH LAND MOBILE ANTENNA SYSTEMS.

II. THEORETICAL CONSIDERATIONS

THE ANTENNA IS A ONE HALF WAVELENGTH RADIATOR ATOP A PARALLEL LINE MATCHING SECTION. IF A ONE HALF WAVELENGTH RADIATOR IS DRIVEN AGAINST A GROUND PLANE A VERY HIGH INPUT IMPEDANCE IS OBSERVED, THIS BEING DUE TO THE CURRENT AND VOLTAGE DISTRIBUTION ON A RESONANT HALF-WAVE ANTENNA. SEE FIGURE 1 BELOW.

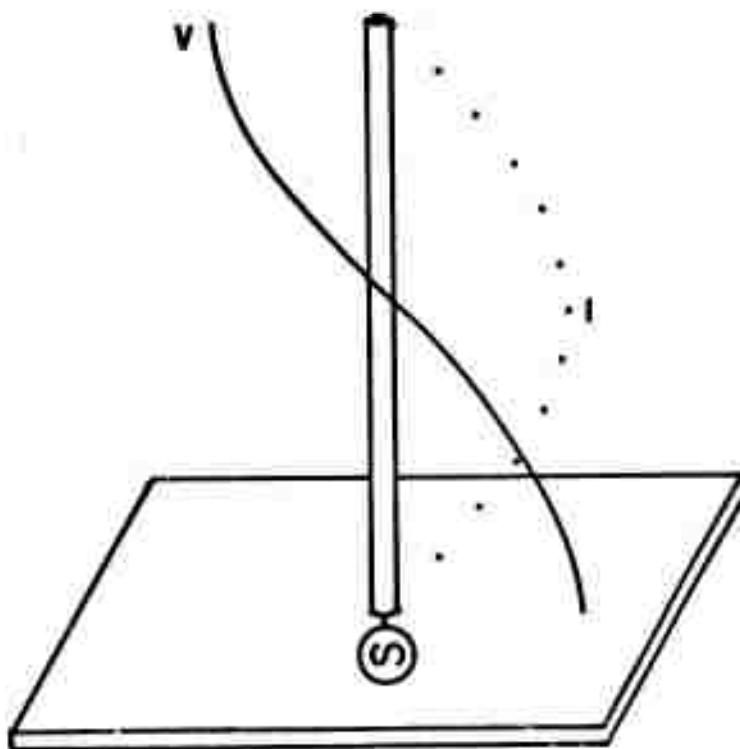

FIGURE 1

VOLTAGE AND CURRENT DISTRIBUTION
ON A HALF-WAVE MONOPOLE

AS THE ABOVE FIGURE SHOWS, THIS ANTENNA EXHIBITS HIGH VOLTAGE AND MINIMUM CURRENT AT THE FEED POINT, THUS A VERY HIGH INPUT IMPEDANCE. EXTENDING THIS CONCEPT FURTHER TO THE CASE OF THE LONG ELEMENT OF A HYBRID DIPOLE, WHICH IS THREE QUARTERS OF A WAVELENGTH LONG, (ELECTRICAL LENGTH) ITS CURRENT AND VOLTAGE DISTRIBUTION SHOULD APPEAR AS SHOWN IN FIGURE 2 BELOW. AGAIN THE ANTENNA IS DRIVEN OVER A GROUND PLANE.

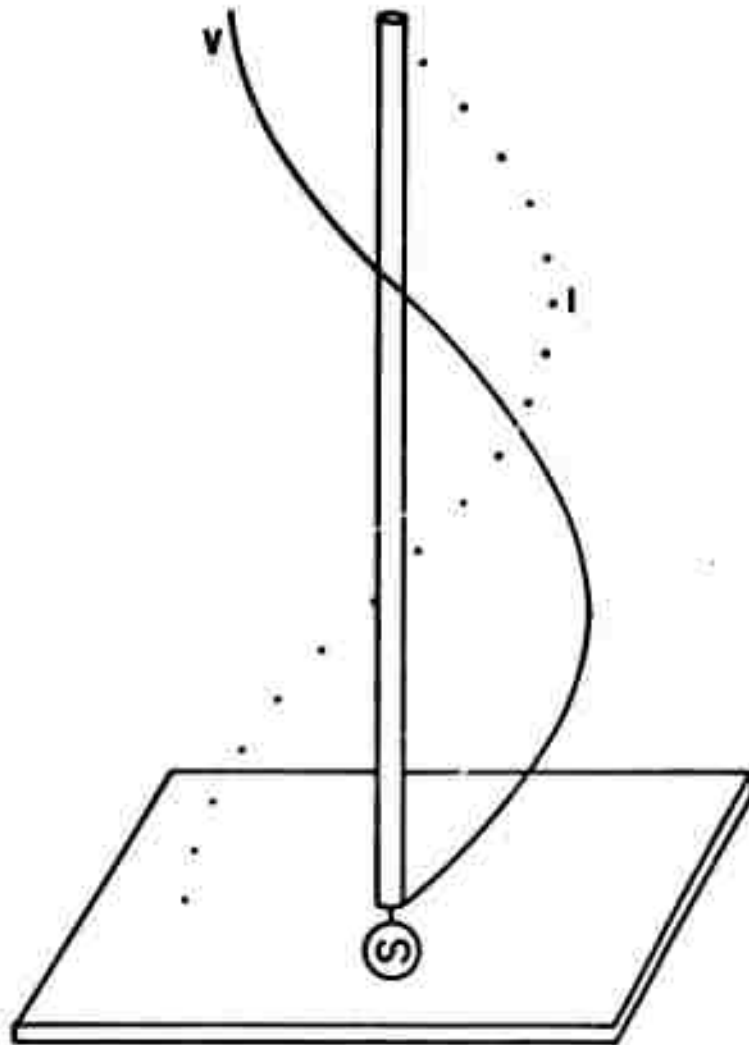

FIGURE 2

VOLTAGE AND CURRENT DISTRIBUTION ON
A THREE QUARTER-WAVE MONOPOLE

THIS FIGURE SHOWS A LOW VOLTAGE AND HIGH CURRENT AT

THE FEED POINT AND THEREFORE, A LOW INPUT IMPEDANCE. MEASURED IMPEDANCES FOR THIS ANTENNA ARE BETWEEN 45 AND 50 OHMS. (3) THIS WOULD BE A GOOD WORKING IMPEDANCE HOWEVER, THE RADIATION OF THIS ANTENNA IS UNDESIRABLE IN MOBILE COMMUNICATIONS. THE ELEVATION RADIATION PATTERN OF THIS ANTENNA IS PRESENTED IN FIGURE 3.

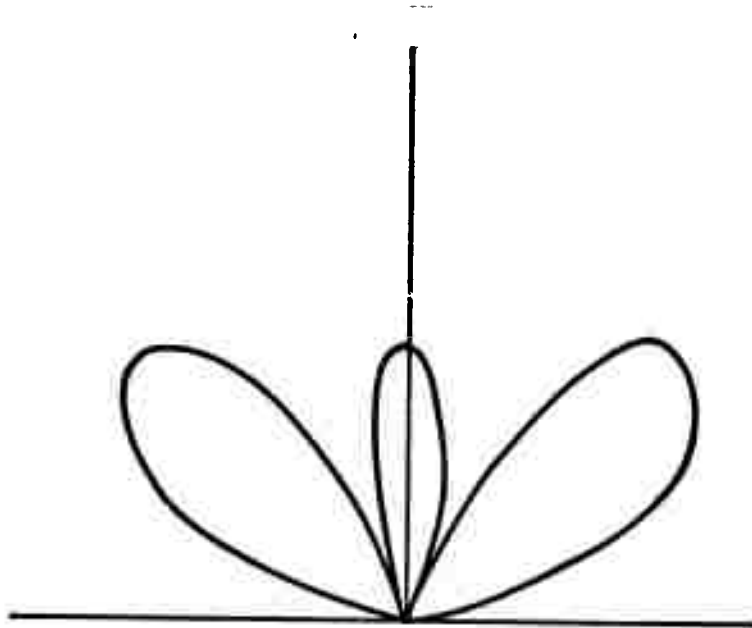

FIGURE 3

ELEVATION RADIATION PATTERN OF THE
THREE QUARTER-WAVE MONOPOLE

IF IN AN ATTEMPT TO CANCEL THIS UNDESIRABLE LOBING EFFECT, (SEE FIGURE 3) ANOTHER RADIATOR IS PLACED IN CLOSE PROXIMITY TO THE 3/4 WAVE ANTENNA AND FED OUT-OF-PHASE WITH THE MAIN ELEMENT, WE CAN ACHIEVE NEAR CANCELLATION OF THE FIELDS IN THE VOLUME SURROUNDING THE SPACE WHERE THESE ELEMENTS ARE PARALLEL. BY MAKING THIS OUT OF PHASE SECTION ONE QUARTER OF

A WAVELENGTH LONG THE ONLY SECTION WHICH WILL RADIATE WITHOUT CANCELLATION SHOULD BE THE TOP ONE HALF WAVELENGTH OF THE THREE QUARTER-WAVE ELEMENT. THIS SECTION SHOULD PRODUCE THE RADIATION CHARACTERISTICS OF A ONE HALF-WAVE DIPOLE, A HIGHLY DESIRABLE RADIATION PATTERN FOR MOBILE COMMUNICATIONS. FIGURE 4 SHOWS THE EXPECTED CURRENT DISTRIBUTION ON THIS HYBRID DIPOLE ANTENNA, NEGLECTING COUPLING EFFECTS.

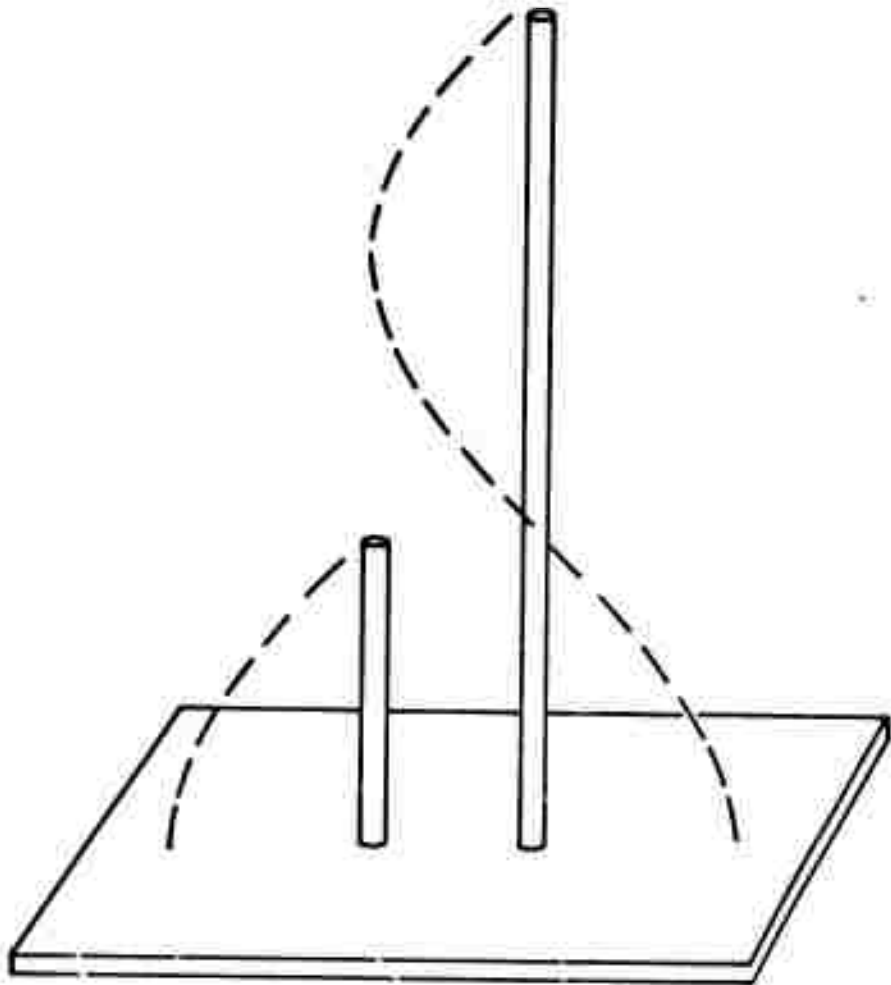

FIGURE 4

EXPECTED CURRENT DISTRIBUTION ON THE HYBRID DIPOLE

CONSIDERING THE QUARTER-WAVE STUB TO BE AN EXTENSION OF THE SHIELD ON THE COAXIAL FEEDLINE, THIS DISTRIBUTION IS QUITE FEASIBLE. FIRST, AT THE TOP END OF THE STUB THE

CURRENT MUST GO TO ZERO. THEREFORE, A CURRENT MAXIMUM WILL EXIST ONE QUARTER OF A WAVELENGTH FROM THIS POINT, OR AT THE BASE OF THE STUB. THIS PRODUCES THE DESIRED PHASE DIFFERENCE BETWEEN THE CURRENTS ON THE SECTIONS OF THE ANTENNA WHERE THE LINES ARE PARALLEL, AND SHOULD RESULT IN THE DESIRED CANCELLATION OF RADIATED FIELDS OVER THE FIRST QUARTER WAVELENGTH OF THE ANTENNA. IF THE INPUT IMPEDANCE IS NOT SEVERELY AFFECTED, THE ANTENNA SHOULD FUNCTION AS DESIRED.

IGNORING THE PRECEDING CURRENT/PHASE RELATIONSHIP THEORY, ANOTHER DEVELOPMENT ALSO PREDICTS THE ANTENNAS PERFORMANCE. ASSUMING THAT THE RADIATING SECTION ON FIGURE 4 HAS A HIGH INPUT IMPEDANCE, AND LOOKING AT THE TWO ELEMENT SECTION AS A ONE QUARTER WAVELENGTH TWO-WIRE TRANSMISSION LINE TRANSFORMER, WITH CHARACTERISTIC IMPEDANCE DETERMINED BY THE ELEMENT SIZE AND SPACING, THE HIGH IMPEDANCE OF THE RADIATOR WILL BE TRANSFORMED TO A MUCH LOWER IMPEDANCE. THESE LINES HAVE EQUAL AND OPPOSITE CURRENTS AND THEREFORE DO NOT RADIATE. IF THE CHARACTERISTIC IMPEDANCE OF THE TRANSFORMER SECTION IS JUDICIOUSLY SELECTED IT SHOULD BE POSSIBLE TO REALIZE A 50 OHM INPUT IMPEDANCE AT THE TRANSFORMER WHERE

$$Z_{in} = Z_0^2 / Z_L \quad (1)$$

IS THE GOVERNING RELATIONSHIP. THUS WITH ELEMENTS OF FIXED SIZE, Z CAN BE CHANGED BY VARYING THE SPACING BETWEEN THE

ELEMENTS. HERE

$$Z_0 = 276 \cdot \log (B/A) \quad \langle 2 \rangle$$

IN THE EXPERIMENTAL STUDY THAT FOLLOWS "B" IS VARIED FROM 1 TO 4 INCHES, (0.012 TO 0.050 LAMBDA) "A" IS FIXED AT 0.125 INCHES, (0.0016 LAMBDA) WHICH PROVIDES A Z SPREAD OF 250 TO 415 OHMS. THE VALUE OF Z IN EQUATION <1> SHOULD BE VARIABLE OVER A WIDE RANGE OF VALUES SIMPLY BY CHANGING THE SPACING BETWEEN THE TWO ELEMENTS.

III. DEVELOPMENT OF ANTENNA CONFIGURATION

A. THE BALANCED FEED HYBRID DIPOLE

EXPERIMENTS WERE FIRST CONDUCTED WITH A BALANCED FEED ANTENNA. THIS ANTENNA APPROXIMATES AN EXTENSION OF A TWO WIRE TRANSMISSION LINE. IN THIS CASE ONE END OF THE TWO WIRE LINE IS TERMINATED IN A FIELD SHORT CIRCUIT, WHILE AT THE OTHER END ONE LINE IS EXTENDED AS THE RADIATOR. CONSIDERING TWO WIRE TRANSMISSION LINE THEORY, THIS FORM OF THE HYBRID DIPOLE SHOULD HAVE THE HIGHEST PROBABILITY OF PRODUCING GOOD PERFORMANCE, SINCE THE TWO WIRE SECTION IS BALANCED. THE QUESTION THAT APPEARS TIME AND AGAIN IS "WHAT IS THE ACTUAL IMPEDANCE AT THE END OF THE TWO WIRE SECTION WHERE THE RADIATOR BEGINS?" THIS QUESTION IS PERTINENT BECAUSE A TWO WIRE LINE SHOULD BE TERMINATED WITH A LOAD ACROSS THE ENDS OF THE TWO LINES, BUT IN THIS CASE, ONE LINE IS LEFT OPEN, WHILE THE OTHER IS CONNECTED TO AN EXTENSION OF ITSELF. THIS TYPE OF "TERMINATION" DOES NOT SEEM TO BE ANALYZABLE. COINCIDING WITH THIS PROBLEM IS THE PROBLEM OF DEFINING THE END POINT IMPEDANCE OF A DIPOLE ANTENNA FOR THIS TOO REQUIRES TWO TERMINALS IN ORDER TO DEFINE IMPEDANCE. THE BALANCED VERSION OF THE HYBRID DIPOLE IS CONSTRUCTED AS

BRIEFLY DESCRIBED ABOVE AND IS GRAPHICALLY PRESENTED IN
FIGURE 5.

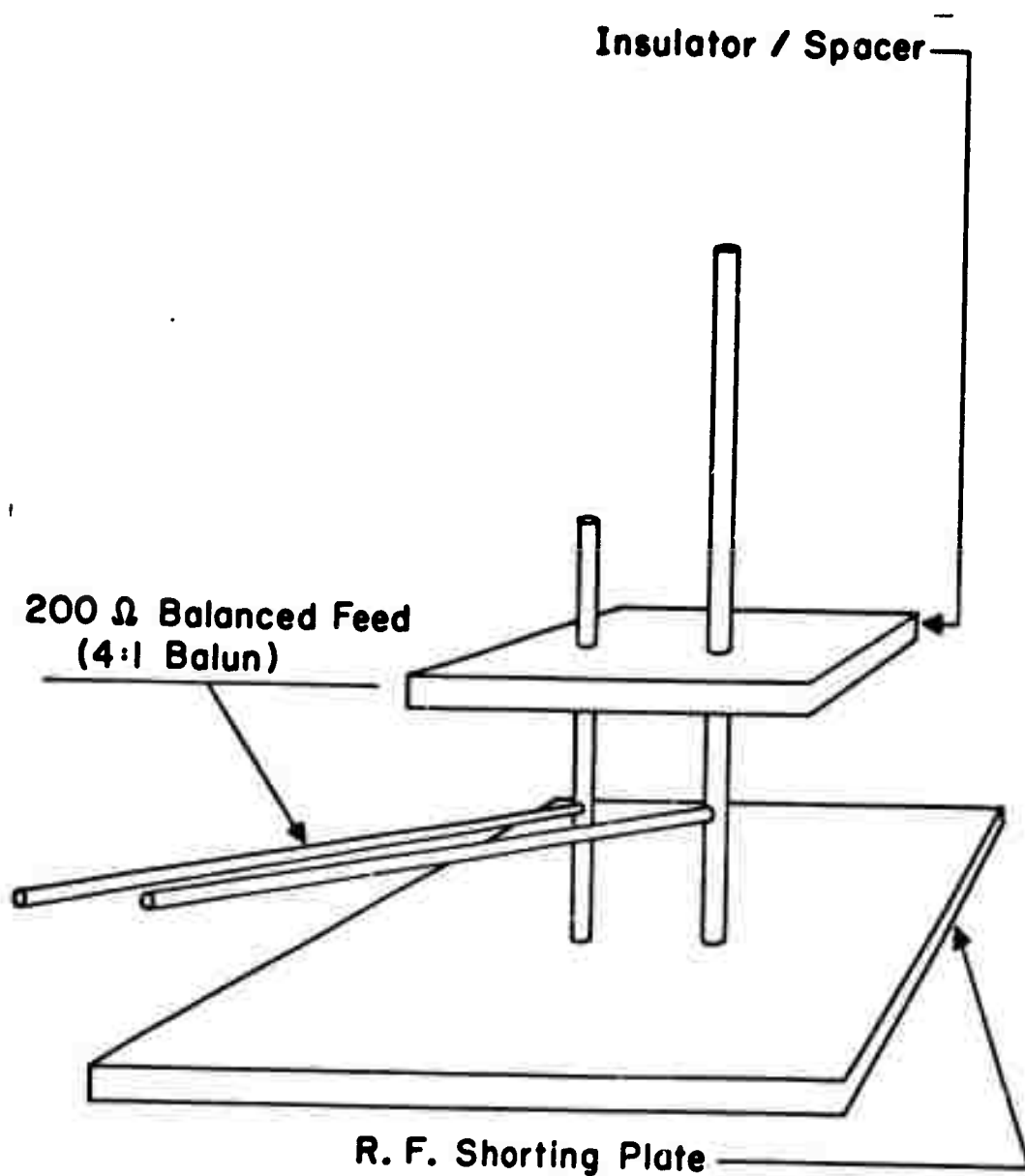

FIGURE 5

THE BALANCED HYBRID DIPOLE

B. IMPEDANCE MEASUREMENTS AND RADIATION PATTERNS

THE IMPEDANCE OF AN ANTENNA IS OF LITTLE IMPORTANCE WHEN CONSIDERED ALONE, FOR A DUMMY LOAD HAS FINE IMPEDANCE CHARACTERISTICS BUT DOES NOT RADIATE. HOWEVER, WHEN TAKEN WITH RADIATION PATTERN AND GAIN MEASUREMENTS, IMPEDANCE TAKES ON MORE SIGNIFICANCE.

THE BALANCED VERSION OF THE HYBRID DIPOLE HAS SEVERAL VARIABLE PARAMETERS, WHICH MAY BE USED TO OBTAIN A GOOD IMPEDANCE MATCH TO THE FEED LINE. THESE ARE: 1) SPACING BETWEEN THE TWO WIRES OF THE MATCHING SECTION, 2) LOCATION OF THE FEED POINT, 3) LENGTH OF THE TWO WIRE SECTION, 4) LENGTH OF THE RADIATING SECTION. THESE WERE ADJUSTED UNTIL THE TRANSMISSION LINE WAS MATCHED TO THE ANTENNA AND TESTS OF IMPEDANCE AND RADIATION PATTERNS WERE CONDUCTED.

MANY FACTORS ARE PRESENT IN A SWEEPED FREQUENCY IMPEDANCE DETERMINATION, HOWEVER, PERHAPS THE MOST RESTRICTIVE FACTOR IN THIS CASE WAS THE NARROW-BAND LOW-LOSS COAXIAL 4:1 BALUN. THIS BALUN IS NECESSARY TO BRING THE UNBALANCED 50 OHM FEEDLINE INTO BALANCE AND RAISE THE IMPEDANCE TO 200 OHMS. THIS VERSION OF LINE BALANCING DEVICE WAS CONSTRUCTED FOR CONVENIENCE AND TO ELEVATE THE FEED POINT FROM THE PROXIMITY OF THE SHORTING PLANE.

THE RADIATION PATTERNS WERE TAKEN AT RESONANCE AND SUPERIMPOSED OVER A REFERENCE DIPOLE IN BOTH AZIMUTH AND ELEVATION. THESE FIRST MEASUREMENTS WERE CONDUCTED IN A SIMULATED FREE SPACE ENVIRONMENT WITH A DISTANT ILLUMINATION SOURCE. THE TWO ANTENNAS WERE WITHIN TENTHS OF A CB IN BOTH PLANES, AS CAN BE SEEN IN FIGURES 6 & 7, THE ACCURACY OF WHICH IS APPROACHING THE MEASUREMENT SYSTEMS STATISTICAL ERROR. SEVERAL RUNS WERE MADE AND SIMILAR RESULTS WERE OBTAINED EACH TIME.

C. DEVELOPMENT OF THE UNBALANCED HYBRID DIPOLE

NEARLY ALL DESIGNS ARE DEVELOPED BECAUSE OF AN UNDERLYING NEED. THE UNBALANCED HYBRID DIPOLE WAS NO EXCEPTION; A PRESSING NEED WAS PRESENT IN THE PROBLEMS CREATED BY THE COAXIAL BALUN AND ATTACHMENT TO THE ANTENNA ELEMENTS. NARROW BANDWIDTH AND LARGE SIZE WERE ELIMINATED BY USE OF A TOROIDAL FERRITE BALUN HOWEVER, THE FERRITE CORE WAS SO FRAGILE THAT IT SHATTERED IN LABORATORY TESTS. THIS STRUCTURAL WEAKNESS COULD NEVER BE TOLERATED IN ACTUAL USE.

THE FEASIBILITY OF USING AN UNBALANCED FEED SYSTEM WAS QUESTIONABLE DUE TO ANTICIPATED CURRENT UNBALANCE. IT WAS FELT HOWEVER, THAT A SLIGHT DEGRADATION IN PERFORMANCE CAUSED BY THIS UNBALANCE COULD BE TOLERATED IF A SIGNIFICANT IMPROVEMENT WAS MADE IN THE FEED SYSTEM MECHANICAL

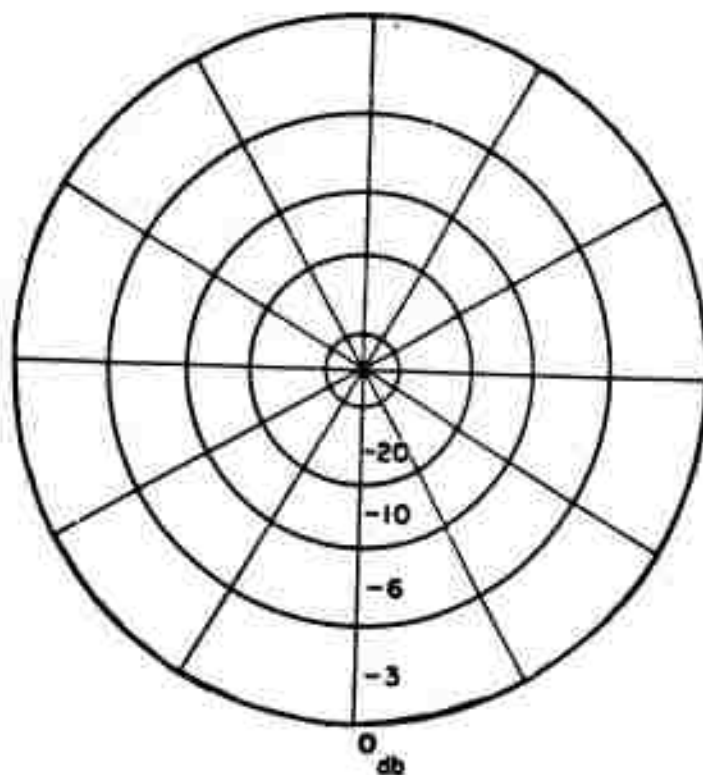

FIGURE 6

AZIMUTH RADIATION PATTERNS OF THE
REFERENCE DIPOLE & BALANCED HYBRID DIPOLE
SUPERIMPOSED

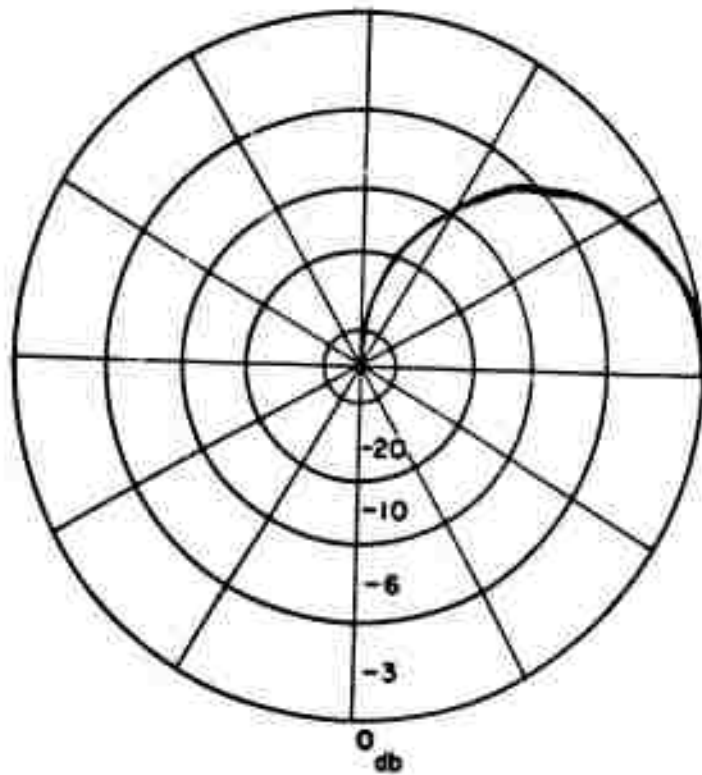

FIGURE 7

ELEVATION RADIATION PATTERNS OF THE
 REFERENCE DIPOLE & BALANCED HYBRID DIPOLE
 SUPERIMPOSED

RELIABILITY. THE UNBALANCED-FEED HYBRID DIPCLE WAS CONSTRUCTED AS SHOWN IN FIGURE 8, AND IS SEEN TO BE MECHANICALLY SUPERIOR TO THE BALANCED CONFIGURATION.

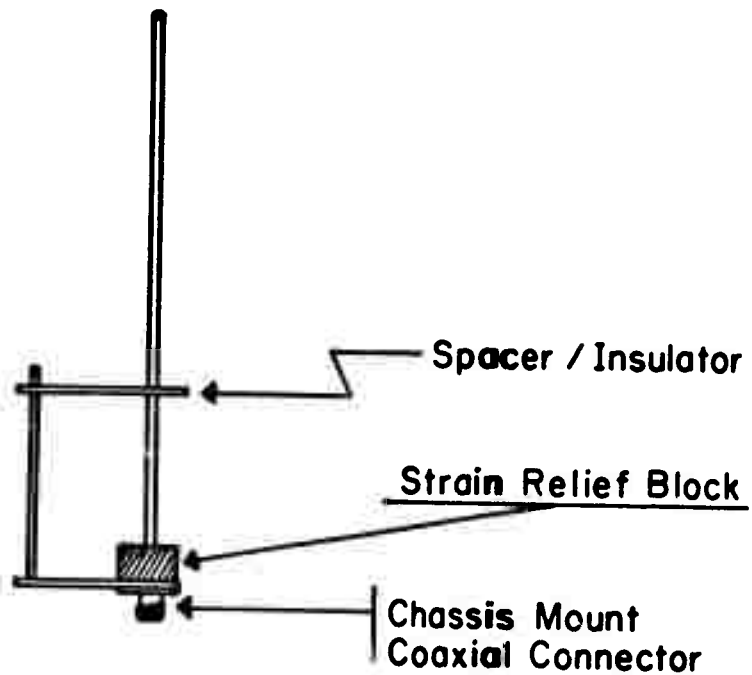

FIGURE 8

THE UNBALANCED HYBRID DIPCLE

A SCHEMATIC REPRESENTATION OF THIS ANTENNA IS PRESENTED IN FIGURE 9.

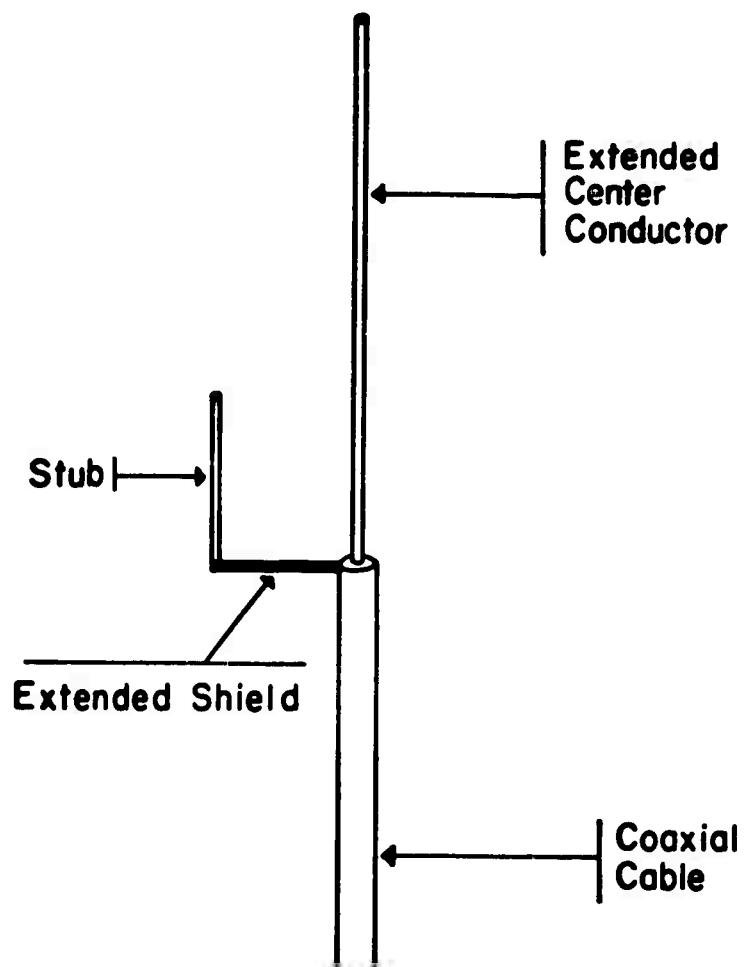

FIGURE 9

SCHEMATIC REPRESENTATION OF UNBALANCED HYBRID DIPOLE

IV. EXPERIMENTAL DEVELOPMENT

FIRST A ONE HALF WAVELENGTH RADIATOR WAS ATTACHED TO THE COAXIAL FITTING AND THE IMPEDANCE MEASURED. AN IMPEDANCE OF APPROXIMATELY 2000 OHMS WAS OBSERVED AT RESONANCE. A HIGH IMPEDANCE WAS EXPECTED AS THIS ANTENNA RESEMBLES AN END-FED HALF WAVE RADIATOR, WHICH IS A VOLTAGE-FED ANTENNA. NEXT A 1/4 WAVELENGTH STUB WAS PLACED ON THE ANTENNA BASE APPROXIMATELY 2 INCHES FROM THE ONE HALF WAVE SECTION AND THE IMPEDANCE WAS AGAIN MEASURED. THIS TIME A RESONANT INPUT IMPEDANCE OF 30 OHMS WAS OBSERVED. THE PLACEMENT OF THE STUB RESULTED IN LOWERING OF THE INPUT IMPEDANCE, A CONDITION WHICH MUST BE MET IF A PROPER IMPEDANCE MATCH IS TO BE OBTAINED FOR DIRECT FEEDING WITH 50 OHM CABLE.

THE NEXT STEPS IN THE DEVELOPMENT WERE ATTACHING A THREE QUARTER WAVELENGTH ELEMENT TO THE COAXIAL FITTING AND PLACING THE ONE QUARTER WAVE STUB APPROXIMATELY 2 INCHES (0.024 LAMBDA) FROM THIS ELEMENT. THE INPUT IMPEDANCE WAS AGAIN MEASURED. A RESONANT IMPEDANCE OF 30 OHMS WAS OBSERVED AND THE RESONANT FREQUENCY WAS FOUND TO BE 1.4% BELOW THE ESTIMATED FREQUENCY OF RESONANCE.

THE TEST ANTENNA HAD BEEN DESIGNED SO THAT VARIOUS

SPACINGS OF THE ONE QUARTER WAVELENGTH STUB WERE AVAILABLE, THEREFORE, THE EFFECT OF SPACING BETWEEN THE TWC ELEMENTS, HOLDING OTHER PARAMETERS CONSTANT, COULD BE TESTED.

IF THE SECTION OF THE ANTENNA WHERE THE TWC ELEMENTS ARE PARALLEL IS ACTING AS A TWC WIRE TRANSMISSION LINE, THEN THE SPACING BETWEEN THE ELEMENTS WILL CHANGE THE CHARACTERISTIC IMPEDANCE OF THE LINE, AS PREVIOUSLY DISCUSSED. ASSUMING THAT THIS TWC WIRE TRANSMISSION LINE IS ACTING AS A QUARTER WAVE TRANSFORMER, THE CHANGE OF CHARACTERISTIC IMPEDANCE WILL DUELY CHANGE THE TRANSFORMATION. MOVING THE TWC ELEMENTS CLOSER TOGETHER SHOULD LOWER THE CHARACTERISTIC IMPEDANCE OF THE LINE, INCREASING THE AMOUNT OF TRANSFORMATION AND THEREBY LOWERING THE INPUT IMPEDANCE. INCREASED SPACING WOULD RESULT IN THE OPPOSITE EFFECT. THIS WAS INDEED FOUND TO BE THE CASE, FOR WHEN THE INPUT IMPEDANCE WAS MEASURED AT ONE INCH SPACING, (0.012 LAMBDA) THE RESONANT IMPEDANCE WAS 16 OHMS. USING THESE TWO OBSERVATIONS IT SEEMED REASONABLE THAT IF THE DISTANCE WAS INCREASED TO FOUR INCHES, (0.050 LAMBDA) THIS CONFIGURATION SHOULD EXHIBIT A HIGHER IMPEDANCE THAN WAS OBSERVED AT THE TWO INCH SPACING. AGAIN THE PREDICTION WAS CORRECT AS A RESONANT IMPEDANCE OF 55 OHMS WAS MEASURED. FIGURES 10 THROUGH 13 ARE THE MEASURED VALUES OF THESE TESTS. FIGURE 14 IS A LINEAR PLOT OF THE RELATIONSHIP

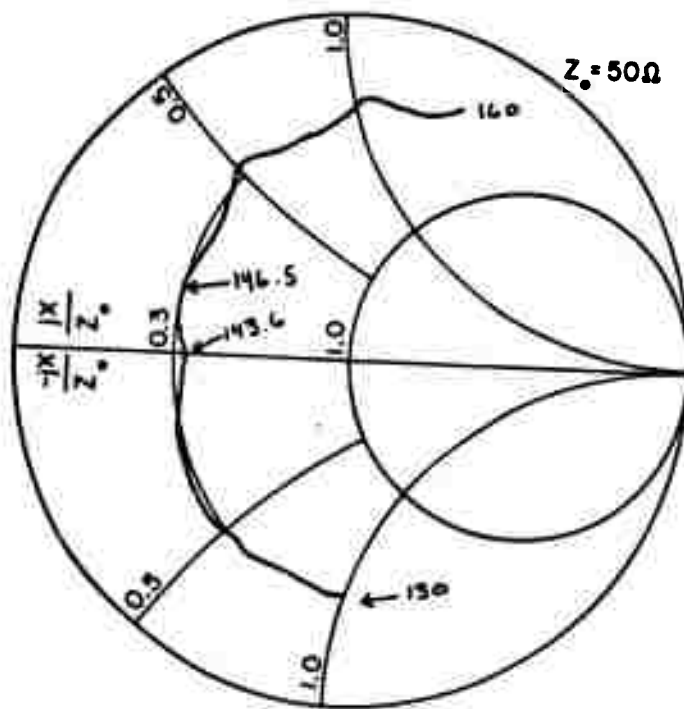

FIGURE 10

INPUT IMPEDANCE OF THE
UNBALANCED HYBRID DIPOLE
AT 1 INCH ELEMENT SPACING

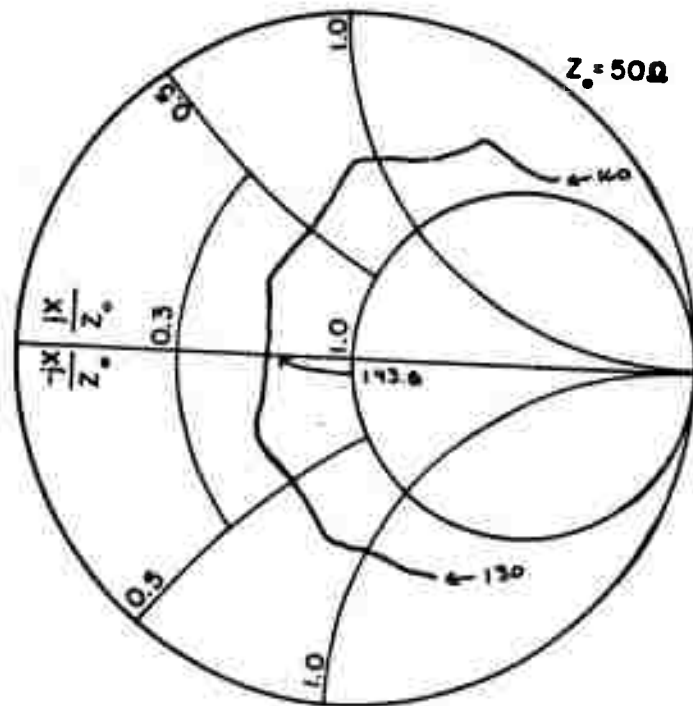

FIGURE 11

INPUT IMPEACANCE OF THE
 UNBALANCED HYBRID COUPLER
 AT 2 INCH ELEMENT SPACING

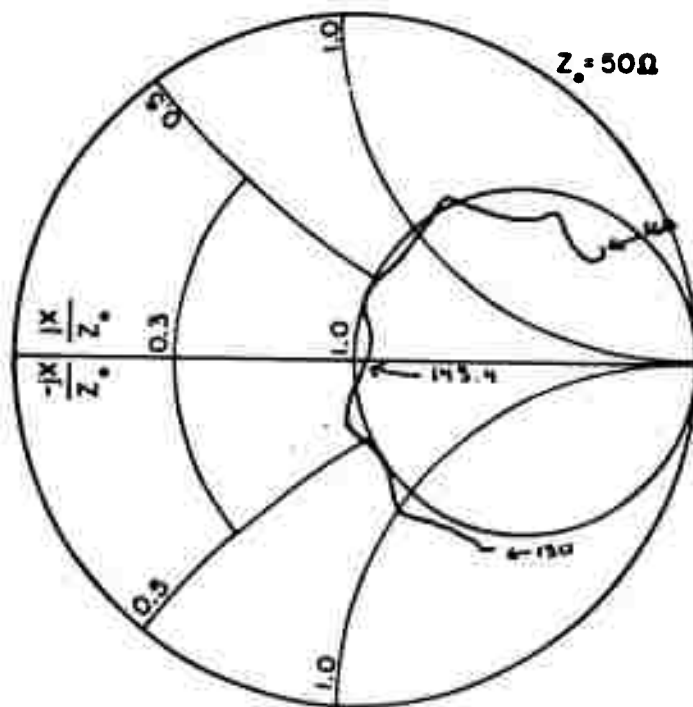

FIGURE 13

INPUT IMPEDANCE OF THE
UNBALANCED HYBRID DIPOLE
AT 4 INCH ELEMENT SPACING

BETWEEN RESISTANCE AND SPACING.

ANOTHER NOTEWORTHY CHANGE WHICH TOOK PLACE AS THE QUARTER WAVELENGTH STUB SPACING VARIED, WAS A CONTINUOUS DROP IN RESONANT FREQUENCY AS THE SPACING INCREASED. A TOTAL DECREASE OF 0.5% OF CALCULATED RESONANT FREQUENCY WAS OBSERVED IN CHANGING FROM ONE INCH TO FOUR INCHES. THIS OBSERVATION INDICATES THAT AS THE SPACING INCREASED THE ELECTRICAL LENGTH OF THE ANTENNA ALSO INCREASED DUE TO MUTUAL COUPLING EFFECTS BETWEEN THE MAIN ELEMENT AND THE QUARTER WAVE STUB. THE SPACING WAS NOT INCREASED BEYOND FOUR INCHES FOR AT THIS DISTANCE, THE CURRENT ON THE STUB MUST FLOW AN ADDITIONAL 18 DEGREES WITH RESPECT TO CURRENT ON THE MAIN ELEMENT. THIS ADDITIONAL PHASE SHIFT, DEGRADES THE CANCELLATION OF FIELDS ENCOMPASSING THE TWO LINE SECTION OF THE ANTENNA AND IT WAS PREDICTED THAT ANY FURTHER INCREASE IN PHASE DIFFERENCE WOULD BE DETRIMENTAL TO THE RADIATION PATTERN PRODUCED BY THE ANTENNA.

IT WAS ANTICIPATED THAT THE ANTENNA COULD EASILY BE ADJUSTED TO PRESENT A GOOD LOAD IMPEDANCE SO THE EFFECTS OF A FINITE GROUND PLANE WERE INVESTIGATED.

A. EFFECT OF A FINITE GROUND PLANE ON THE
UNBALANCED HYBRID DIPOLE

IN AS MUCH AS FREE SPACE MEASUREMENTS ARE ONLY GOOD FOR

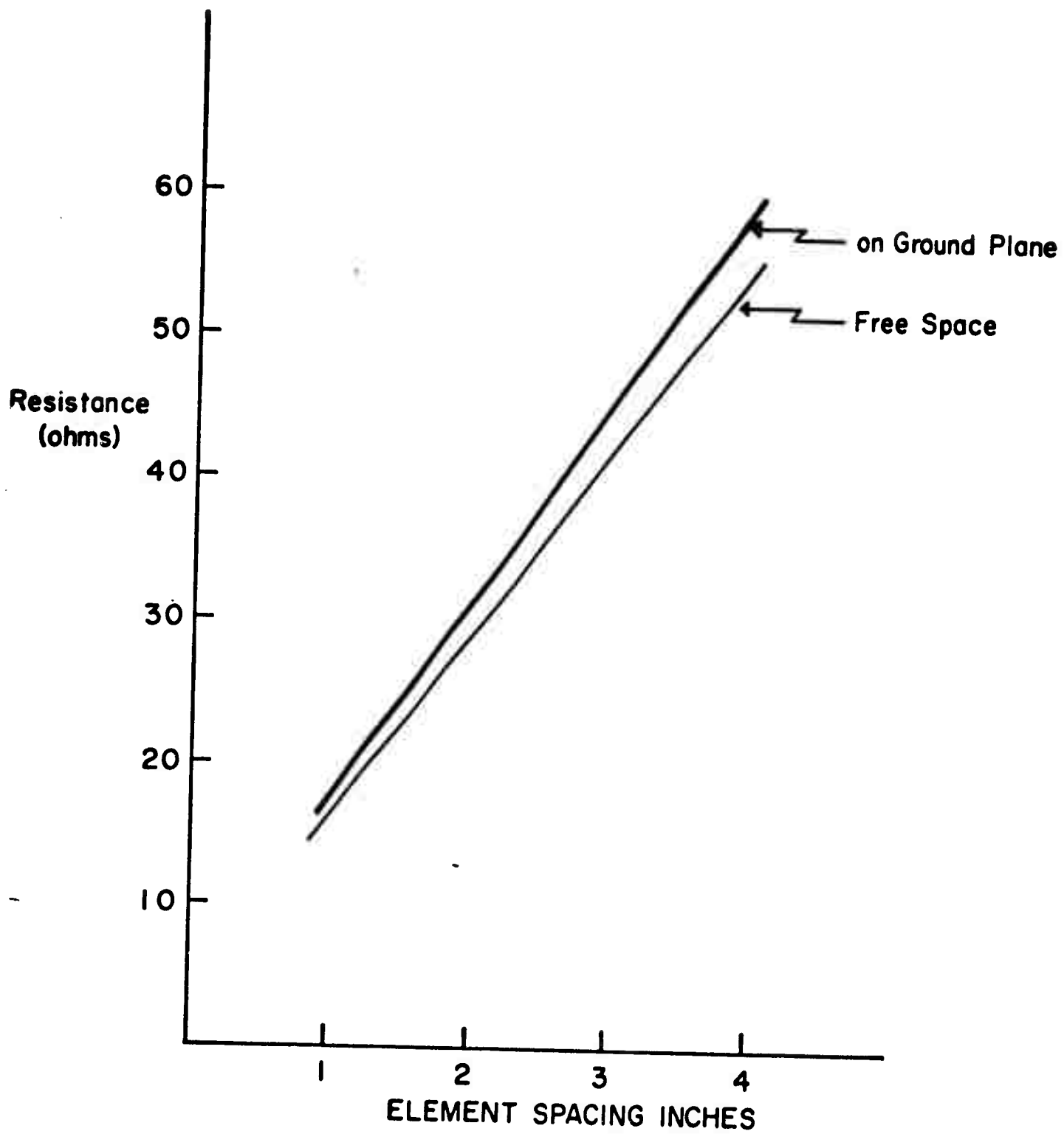

THEORETICAL COMPARISONS, THE HYBRID DIPOLE WAS BROUGHT DOWN TO EARTH. A FOUR BY EIGHT FOOT ALUMINUM SHEET GROUND PLANE WAS USED TO SIMULATE A VEHICULAR ROOF. ITS MEASUREMENTS IN TERMS OF WAVELENGTHS ARE 0.55 BY 1.19 RESPECTIVELY, AND LARGER THAN MANY VEHICLE ROOFS.

THE FIRST SERIES OF EXPERIMENTS WERE DONE WITH THE SAME UNBALANCED HYBRID DIPOLE USED IN THE FREE SPACE TESTS. THE ANTENNA WAS MOUNTED AS SHOWN IN FIGURE 15.

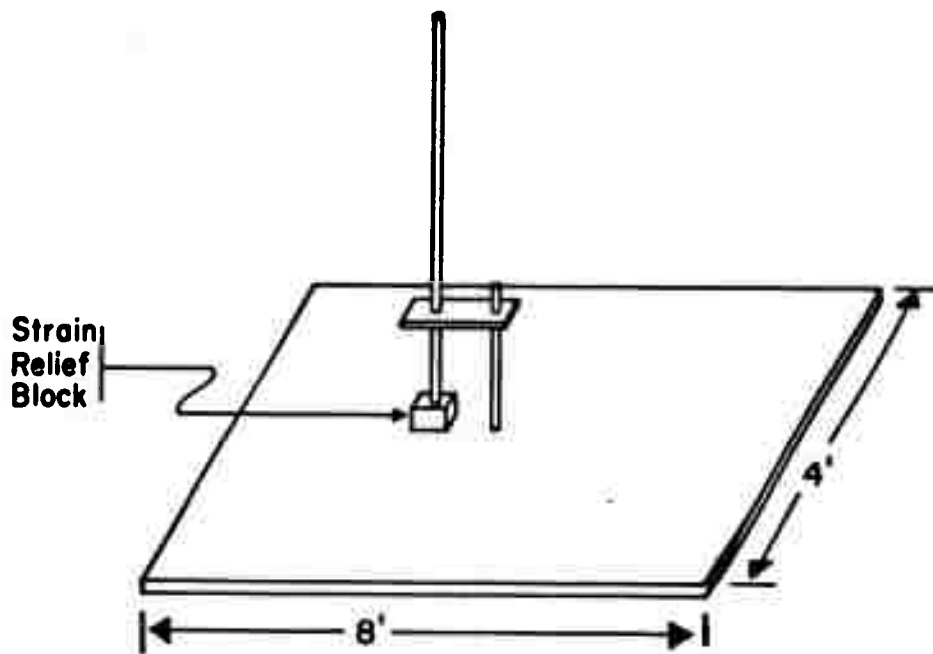

FIGURE 15

THE UNBALANCED HYBRID DIPOLE MOUNTED ON GROUND PLANE

INPUT IMPEDANCE MEASUREMENTS WERE MADE AND CHANGES FROM THE FREE SPACE VALUES NOTED. FIRST THE INPUT IMPEDANCE INCREASED SLIGHTLY IN ALL CASES. THE MOST MARKED CHANGES

OCCURED AT THE THREE AND FOUR

WITH THE STUB SET AT THE THREE INCH SPACING, THE EFFECT OF LENGTHENING AND SHORTENING THE STUB WAS INVESTIGATED. THIS WAS EASILY ACCOMPLISHED BY CHANGING THE AMOUNT THE STUB WAS SCREWED INTO THE GROUND PLANE. LENGTHENING THE STUB BY ONE EIGHTH OF AN INCH (0.00155) INCREASED THE IMPEDANCE AT RESONANCE BY 5 OHMS (SEE FIGURES 16,17). APPLYING TWO-WIRE TRANSMISSION LINE THEORY IN AN ATTEMPT TO PROVIDE A THEORETICAL EXPLANATION OF THIS CHANGE RESULTED IN PREDICTED CHANGES OF ONLY 0.025 OHMS. THE CONCLUSION REACHED FROM THIS OBSERVATION WAS THAT CROSS COUPLING AND MUTUAL IMPEDANCE EFFECTS PREDOMINATE IN THIS INSTANCE, SINCE THE NEAR FIELDS ARE STRONG AND NOT TOTALLY CANCELLED. THUS, SMALL CHANGES IN THE ANTENNA PARAMETERS CAN RESULT IN CONSIDERABLE IMPEDANCE VARIANCES. THIS OBSERVATION IN CONJUNCTION WITH THE PREVIOUS BEHAVIOR EXHIBITED BY THE ANTENNA AS THE SPACING OF THE ELEMENTS VARIED STRONGLY INDICATES THAT THE TWO ELEMENTS ARE NOT BEHAVING AS A TWO-WIRE TRANSMISSION LINE.

FOLLOWING THIS SERIES OF MEASUREMENTS, THE ANTENNA WAS RAISED TO SIX AND TWELVE INCHES ABOVE THE GROUND PLANE. THE INPUT IMPEDANCE WAS MEASURED AT BOTH HEIGHTS. A NOTICEABLE DECREASE IN INPUT IMPEDANCE WAS APPARENT. FIGURE 18 SHOWS IMPEDANCE FOR THREE INCH ELEMENT SPACING, ON THE GROUND

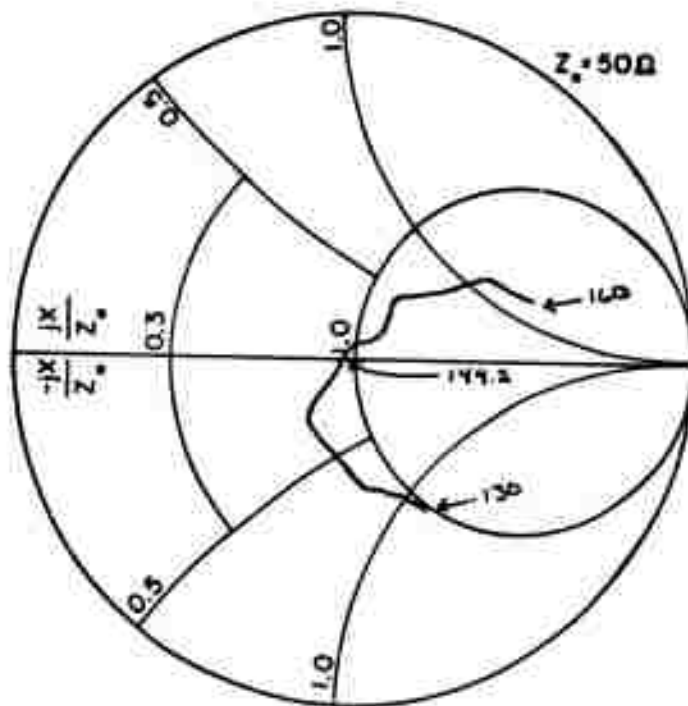

FIGURE 16

INPUT IMPEDANCE OF THE
 UNBALANCED HYBRID DIPOLE
 AT 3 INCH ELEMENT SPACING
 STUB LENGTH NORMAL

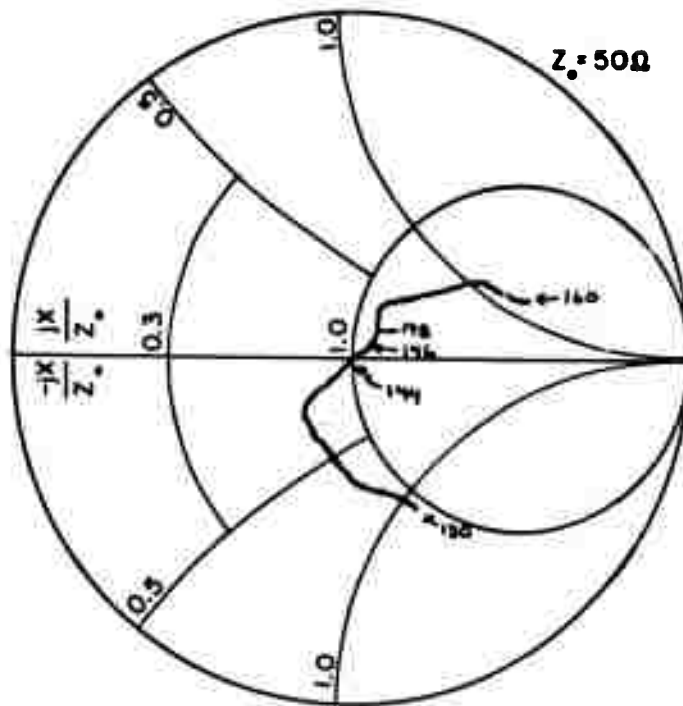

FIGURE 17

INPUT IMPEDANCE OF THE
 UNBALANCED HYBRID DIPOLE
 AT 3 INCH ELEMENT SPACING
 STUB LENGTHENED 1/8 INCH

PLANE , SIX INCHES (0.07) AND TWELVE INCHES (0.14) ABOVE THE GROUND PLANE. AT SIX AND AT TWELVE INCHES AN INPUT IMPEDANCE OF 35 OHMS WAS MEASURED. THE DIFFERENCE IN THE IMPEDANCE CURVES AT SIX AND TWELVE INCHES ARE BARELY DISTINGUISHABLE. INCREASING THE ELEMENT SPACING TO FOUR INCHES INCREASED THE IMPEDANCE TO 40 OHMS AND DECREASING THE SPACING TO ONE INCH LOWERED THE IMPEDANCE TO 17 OHMS. THIS SAME TREND IN IMPEDANCE CHANGE WAS OBSERVED WHEN THE ANTENNA WAS MEASURED IN SIMULATED FREE SPACE AND ON THE SURFACE OF THE GROUND PLANE.

THE SAME MEASUREMENTS AS ABOVE WERE TAKEN WITH THE ANTENNA MOUNTED OFF-CENTER (UNSYMMETRICAL) ON THE GROUND PLANE. THIS UNSYMMETRICAL PLACEMENT OF THE ANTENNA IN RESPECT TO THE RECTANGULAR GROUND PLANE, PRODUCED NEGLIGIBLE IMPEDANCE DIFFERENCES. THIS AND THE PREVIOUS OBSERVATIONS INDICATE THAT THE UNBALANCED HERTZ DIPOLE IS NOT GREATLY EFFECTED IN TERMS OF IMPEDANCE, BY THE PROXIMITY OF THE GROUND PLANE.

B. ANTENNA PATTERNS

RADIATION PATTERNS WERE RUN TO DETERMINE THE EFFECT OF THE GROUND PLANE ON THE PREVIOUSLY OBSERVED SIMULATED FREE SPACE MEASUREMENTS. THE UNBALANCED ANTENNA WAS MOUNTED DIRECTLY ON THE GROUND PLANE AND RADIATION PATTERNS TAKEN IN

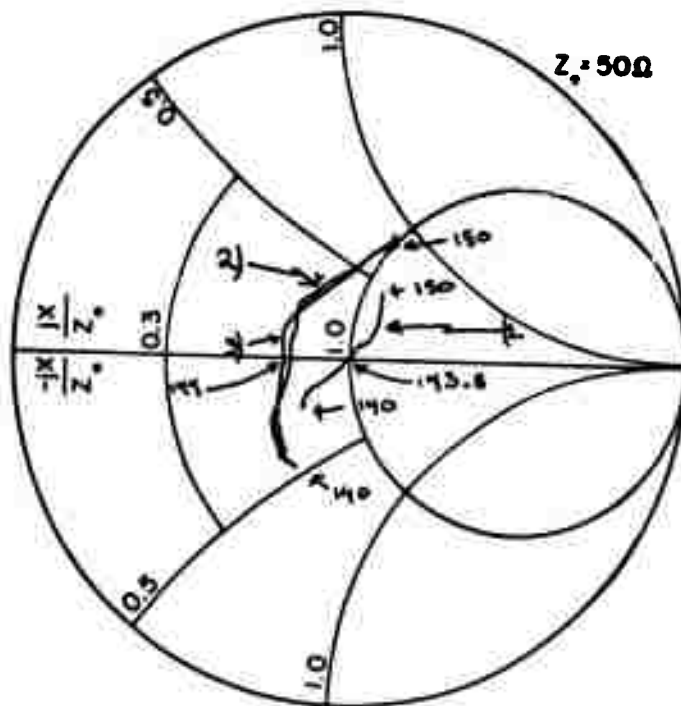

FIGURE 18

INPUT IMPEDANCE OF UNBALANCED
 HYBRID DIPOLE: 1) ON GROUND PLANE
 2) 6 INCHES ABOVE G.P. 3) 12 INCHES ABOVE G.P.

BOTH AZIMUTH AND ELEVATION . APPLYING RECIPROCITY THE RECEIVE CHARACTERISTICS WERE RECORDED WHILE USING A DISTANT ILLUMINATOR AS A SOURCE.

THE AZIMUTH PATTERN DISPLAYED BY THE ANTENNA WAS CONSIDERABLY DEGRADED IN RESPECT TO THE CIRCULAR ELEVATION PATTERN RECORDED IN FREE SPACE. A 4 DB NULL WAS OBSERVED AS THE MAIN RADIATOR FACED THE ILLUMINATOR. THERE WERE OTHER PATTERN DISTORTIONS BUT NONE AS MARKED AS IN THIS ASPECT. (SEE FIGURE 19 & 20). THE ELEVATION PATTERN NO LONGER EVEN RESEMBLED THAT OF THE DIPOLE BUT WAS REDUCED IN GAIN AND DISTORTED. WHILE THE MAIN LOBE WAS ONLY 0.5 DB DOWN FROM THE REFERENCE DIPOLE THE REST OF THE PATTERN FELL FAR SHORT OF EVEN APPROACHING THE DIPOLE. RADIATION DIRECTLY OFF THE END OF THE ANTENNA WAS - 20 DB FROM THE MAIN LOBE. (SEE FIGURE 21).

WHEN THE ANTENNA WAS RAISED SIX INCHES ABOVE THE GROUND PLANE THE PERFORMANCE IMPROVED CONSIDERABLY. THE LARGEST NULL IN THE AZIMUTH PATTERN WAS -1.5 DB FROM THE REFERENCE ANTENNA. LOBBING WAS NOTED WHICH CORRESPONDED TO THE SHAPE OF THE GROUND PLANE. (SEE FIGURE 22). AS CAN BE PLAINLY SEEN IN THIS FIGURE THE GROUND PLANE IS CAUSING DETERIORATION IN THE RADIATION PATTERN. NOTE ALSO THAT RADIATION IS STRONGER OFF THE SIDES OF THE GROUND PLANE WHERE THERE IS LESS GROUND PLANE TO DEGRADE THE ANTENNAS

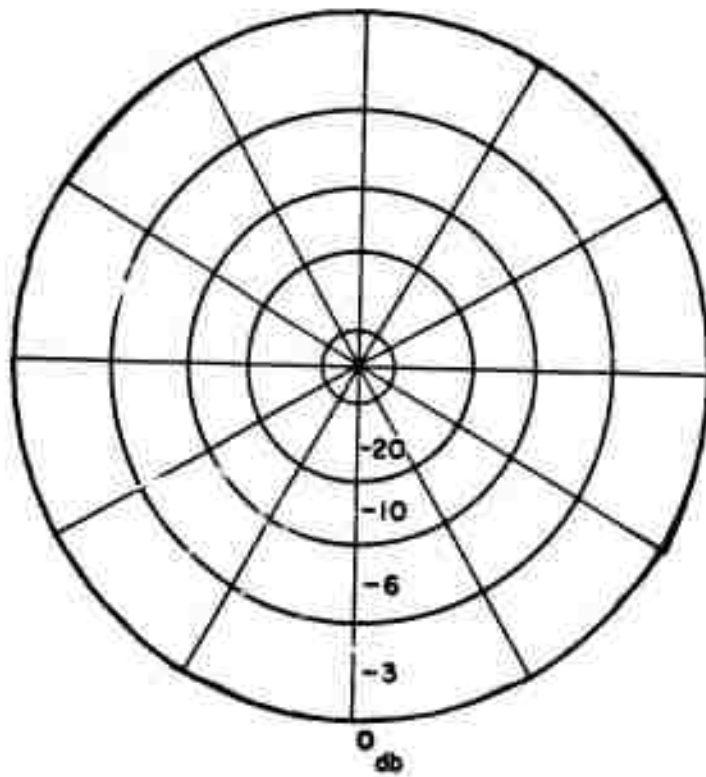

FIGURE 19

AZIMUTH RADIATION PATTERN OF THE
UNBALANCED HYBRID DIPOLE IN FREE SPACE

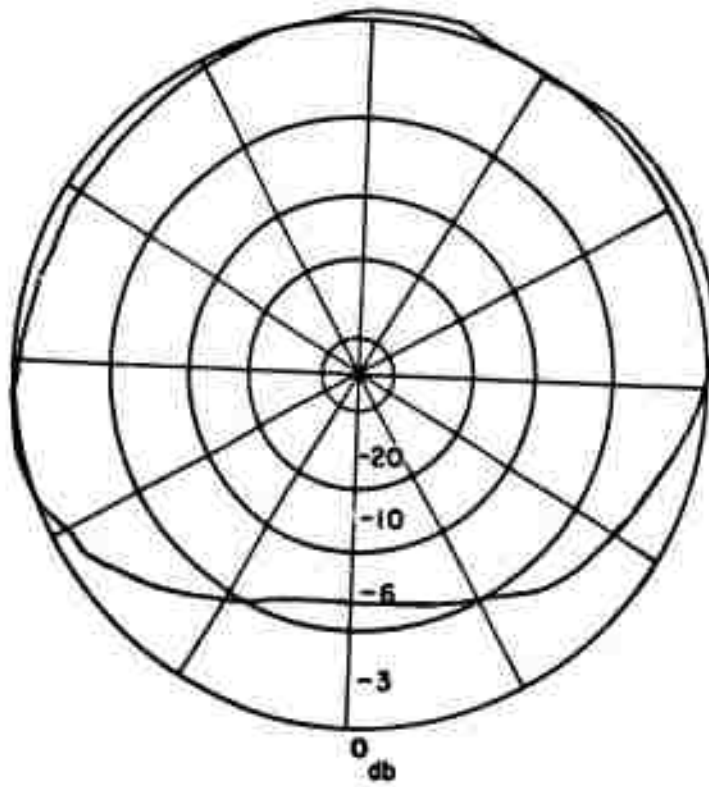

FIGURE 20

AZIMUTH RADIATION PATTERN OF THE
UNBALANCED HYBRID DIPOLE
MOUNTED ON GROUND PLANE

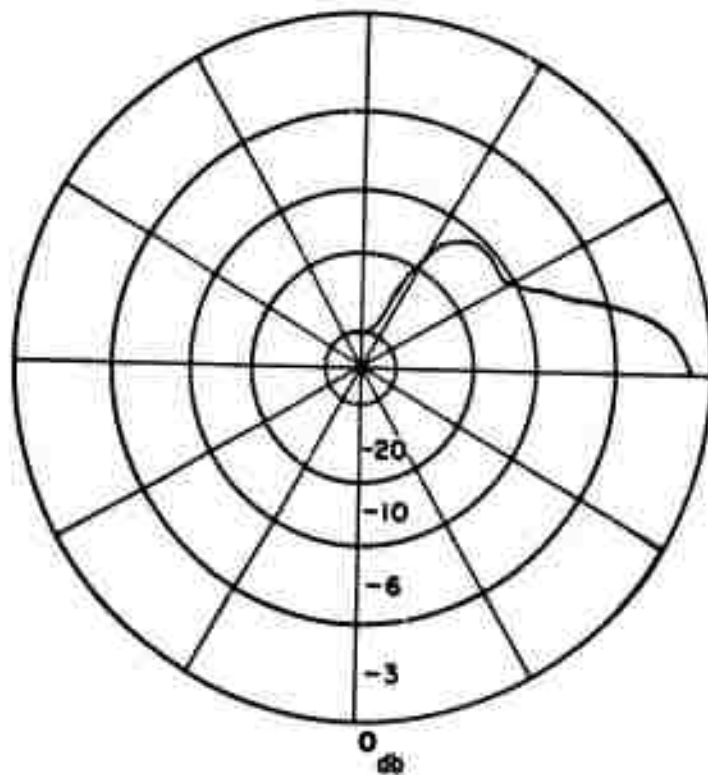

FIGURE 21

ELEVATION RADIATION PATTERN OF THE
UNBALANCED HYBRID DIPOLE
MOUNTED ON GROUND PLANE

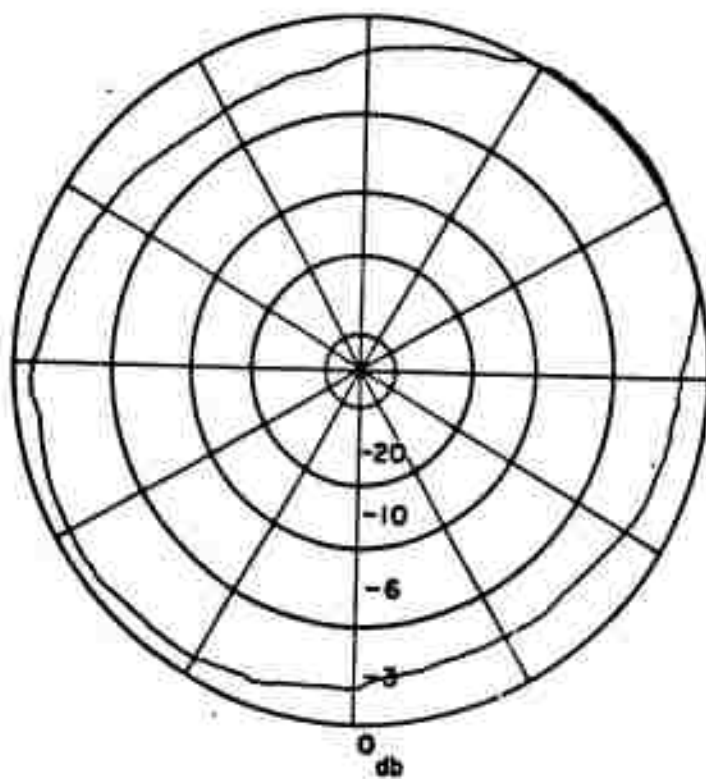

FIGURE 22

AZIMUTH RADIATION PATTERN OF THE
UNBALANCED HYBRID DIPOLE
6 INCHES ABOVE GROUND PLANE

PERFORMANCE. THE AZIMUTH RADIATION PATTERN HOWEVER, WAS MUCH IMPROVED AND RESEMBLED THE REFERENCE DIPOLE ONCE AGAIN. THE MAJOR LOBE IN THIS PLANE WAS APPROXIMATELY 10 DEGREES ABOVE THE HORIZON. (SEE FIGURE 23). THE RESULTS AT THE TWELVE INCH HEIGHT WERE WITHIN EXPERIMENTAL LIMITS OF BEING IDENTICAL TO THOSE OBTAINED AT SIX INCHES. THIS SIMILARITY WAS ALSO NOTED IN THE IMPEDANCE MEASUREMENTS.

AZIMUTH AND ELEVATION RADIATION PATTERNS WERE NEXT TAKEN WITH THE ANTENNA ASYMMETRICALLY MOUNTED ON THE GROUND PLANE. ELEVATION PATTERNS WERE RECORDED FROM BOTH SIDES OF THE GROUND PLANE TO EXAMINE THE EFFECT OF LOOKING ACROSS A LONG DISTANCE OF METAL AS OPPOSED TO A SHORT PIECE. WHEN THE ANTENNA LOOKED ACROSS THE LONG SIDE OF THE GROUND PLANE, THE ELEVATION PATTERN WAS SMOOTH BUT SHOWED CONSIDERABLE RADIATION AT HIGH ELEVATION ANGLES. WHEN THE ILLUMINATOR WAS VIEWED ACROSS THE SHORT SIDE OF THE GROUND PLANE THE PATTERN WAS NOT AS SMOOTH AND ITS GAIN DROPPED OFF RAPIDLY FROM THE MAIN LOBE VALUE. IT ALSO EXHIBITED LESS GAIN THAN WHEN VIEWED FROM THE LONG SIDE. THE AZIMUTHAL PATTERN HAD SEVERAL LOBES, AND THE GAIN ONLY REACHED UNITY IN ONE 15 DEGREE SECTOR. RAISING THE ANTENNA ABOVE THE GROUND PLANE AT THIS OFFSET LOCATION INCREASED THE ANTENNA'S GAIN IN RESPECT TO THE ELEVATION PATTERN, BUT DID NOT SIGNIFICANTLY CHANGE THE RESULTS IN AZIMUTH RADIATION. THE DECOUPLING OF THE ANTENNA

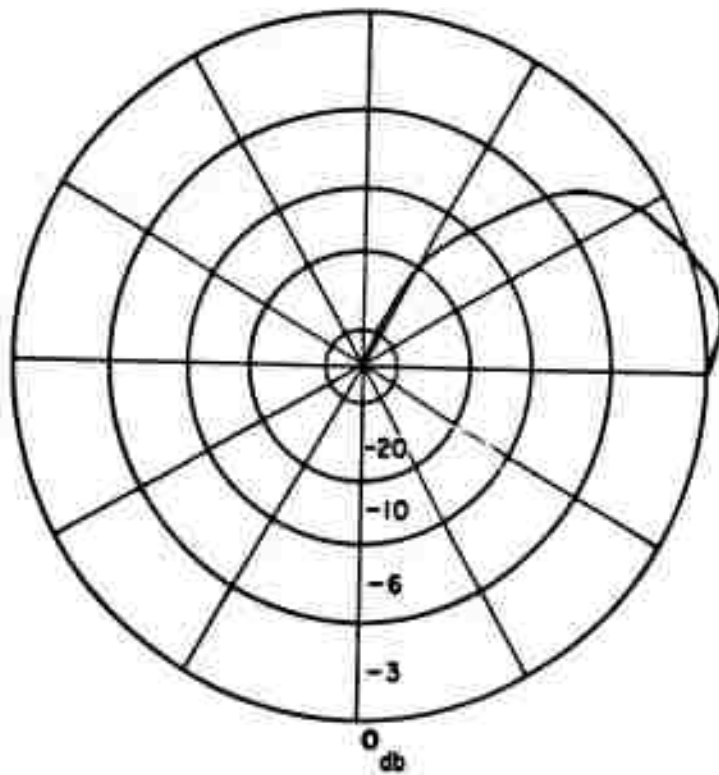

FIGURE 23

ELEVATION RADIATION PATTERN OF THE
 UNBALANCED HYBRID DIPOLE
 6 INCHES ABOVE GROUND PLANE

FROM THE GROUND PLANE INCREASED THE ANTENNAS EFFECTIVENESS, HOWEVER, THE PERFORMANCE WAS DEGRADED IN RESPECT TO THE SYMMETRICALLY MOUNTED CASE. THIS WOULD INDICATE THAT, DEPENDING ON LOCATION, THE CURRENTS FLOWING ON A SMALL GROUND PLANE COULD BE USED TO ADVANTAGE, IF THE CORRECT PHASE RELATIONSHIPS WERE ESTABLISHED.

AS A MATTER OF INTEREST, A BALANCED VERSION OF THE HYBRID DIPOLE WAS MOUNTED ON THE CENTER OF THE GROUND PLANE. THE RADIATION PATTERNS WERE NEARLY IDENTICAL IN BOTH AZIMUTH AND ELEVATION TO THOSE OBTAINED WHEN THE UNBALANCED HYBRID DIPOLE WAS MOUNTED IN THE CENTER OF THE GROUND PLANE. (SEE FIGURES 24,25)

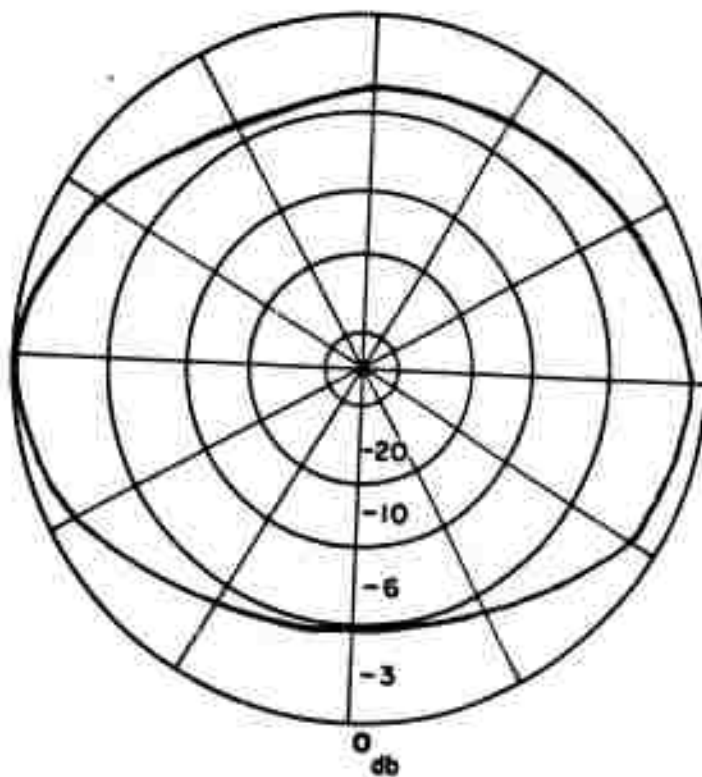

FIGURE 24

AZIMUTH RADIATION PATTERN OF THE
BALANCED HYBRID DIPOLE
MOUNTED ON GROUND PLANE

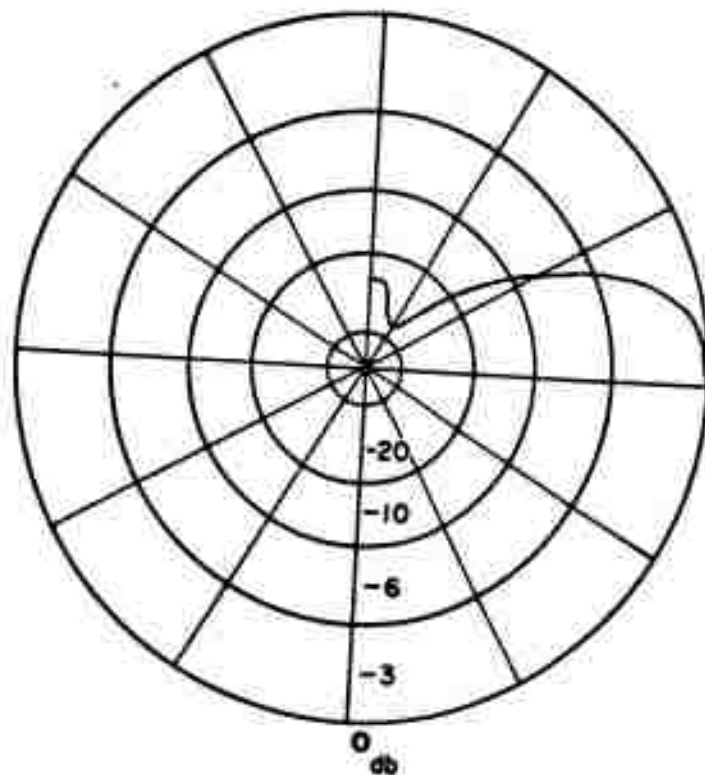

FIGURE 25

ELEVATION RADIATION PATTERN OF THE
BALANCED HYBRID DIPOLE
MOUNTED ON GROUND PLANE

V. CONCLUSION AND RECOMMENDATIONS

FROM THE EXPERIMENTAL RESULTS IT IS OBVIOUS THAT THE HYBRID DIPOLE EQUALS THE PERFORMANCE OF A HALF-WAVE DIPOLE. THE MATCHING SECTION OF THE UNBALANCED HYBRID DIPOLE IS NOT A TWO-WIRE LINE QUARTER-WAVE TRANSFORMER, BUT RATHER THE STUB FUNCTIONS AS A PARASITIC ELEMENT WHICH CANCELS THE UNDESIREED RADIATION, WHILE MAINTAINING THE IMPEDANCE OF THE ANTENNA. THIS IS SUPPORTED BY THE FACT THAT BY USING TRANSFORMER THEORY THE IMPEDANCE SHOULD HAVE VARIED OVER A WIDER RANGE OF VALUES, THE LENGTH OF THE STUB SHOULD NOT HAVE HAD NEARLY THE EFFECT OBSERVED, AND THE OBVIOUS CARDIOID PATTERN OF THE GROUND PLANE MOUNTED UNBALANCED HYBRID DIPOLE, (REFER TO FIGURE 19) WHICH INDICATES THE STUB AIDED BY THE GROUND PLANE IS ACTING AS A DIRECTOR.

IT IS ALSO EVIDENT THAT THE GROUND PLANE DEGRADES THE PERFORMANCE OF THE ANTENNA, ESPECIALLY WHEN THE ANTENNA IS PLACED DIRECTLY ON THE GROUND PLANE, HOWEVER, THIS CAN BE MINIMIZED BY RAISING THE ANTENNA A FEW INCHES ABOVE THE GROUND PLANE. THE AZIMUTH RADIATION PATTERNS CONSISTENTLY SHOW STRONGER RADIATION ORTHOGONAL TO THE GROUND PLANE ORIENTATION. THIS IS THE REVERSE OF WHAT ONE WOULD EXPECT

FROM ANTENNA FOLKLORE, "THE BIGGER THE GROUND PLANE THE BETTER THE PERFORMANCE", HOWEVER, THE CURRENTS FLOWING ON THE GROUND PLANE ACTUALLY CANCEL EACH OTHER TO A GREATER EXTENT OVER THE LONGER SPAN OF METAL SURFACE, RESULTING IN REDUCED ANTENNA PERFORMANCE ALONG THE LONG DIMENSION OF THE GROUND PLANE. THE POINT AT WHICH THIS WILL NO LONGER HOLD TRUE IS WHEN CURRENT FLOW IS UNIDIRECTIONAL, THAT IS, MINIMAL REFLECTED CURRENT IS BEING RETURNED FROM THE EDGE OF THE GROUND PLANE. WHEN THIS POINT IS REACHED THE GROUND PLANE WILL APPROACH THE PERFORMANCE OF AN INFINITE GROUND PLANE FOR THAT FREQUENCY (AND HIGHER FREQUENCIES) AT WHICH THE MEASUREMENTS ARE BEING TAKEN.

THE BALANCED FED HYBRID DIPOLE ALSO PRODUCES PERFORMANCE EQUAL TO THAT OF A 1/2 WAVE DIPOLE, IN FACT IN SEVERAL FREE SPACE TESTS THE RADIATION PATTERNS WERE COINCIDENT. THIS PERFORMANCE IS 0.3 TO 0.5 DB BETTER THAN THE UNBALANCED HYBRID DIPOLE, WHICH CONSISTANTLY HAD SLIGHTLY LESS GAIN THAN THE REFERENCE DIPOLE. VARIOUS BALANCED ANTENNAS HAVE BEEN CONSTRUCTED FOR USE OVER THE FREQUENCY RANGE OF 28 TO 450 MHZ. ALL HAVE GIVEN EXCELLENT PERFORMANCE, BOTH ON THE ANTENNA RANGE AND IN FIELD USE. THE SLIGHTLY GREATER PERFORMANCE OF THIS ANTENNA IS PROBABLY BECAUSE CURRENTS FLOWING ON THE MATCHING SECTION ARE BETTER PHASED AND OF EQUAL MAGNITUDE. THE MATCHING SECTION OF THIS

ANTENNA IS MUCH CLOSER TO BEING A TWO WIRE-LINE QUARTER WAVELENGTH TRANSFORMER THAN THE UNBALANCED VERSION. IN FACT, THE SECTION OF THE ANTENNA FROM THE SPLITTING PLANE TO THE FEED POINT IS A PARALLEL WIRE-LINE. THE BETTER BALANCE AND PHASING RESULT IN MORE NEARLY PERFECT FIELD CANCELLATION AND A SLIGHTLY HIGHER PERFORMANCE.

EXPERIMENTAL RECOMMENDATIONS ARE THAT A CURRENT PROBE BE CONSTRUCTED AND THE MAGNITUDE AND PHASE RELATIONSHIPS OF CURRENT ON THE ELEMENTS OF THE HYBRID DIPOLE BE MEASURED. FOLLOWING THIS INVESTIGATION A GROUND PLANE SIMULATING A SHIP'S HULL AND SUPERSTRUCTURE WOULD GIVE RESULTS WHICH ARE MORE MEANINGFUL FOR NAVAL APPLICATIONS OF THE HYBRID DIPOLE. ALSO OF INTEREST IS THE EFFECTS OF CURVED GROUND PLANES AND OTHER SHAPES SIMULATING DIFFERENT VEHICLE ROOFS.

THEORETICAL INSIGHT CAN FURTHER BE DEVELOPED BY APPLYING WIRE ANTENNA THEORY TO THE HYBRID DIPOLE. IF ONE OF THE MANY AVAILABLE ANTENNA NUMERICAL MODELING COMPUTER PROGRAMS WERE ADAPTED TO HANDLE THIS GEOMETRY, MANY CONFIGURATIONS COULD BE TRIED BEFORE EXPERIMENTAL VERIFICATION.

APPENDIX A

PRACTICAL CONSTRUCTION FORMULAS FOR

BUILDING HYBRID DIPOLES.

A. THE BALANCED HYBRID

FOR VHF AND UHF FREQUENCIES THE ANTENNA IS SELF SUPPORTING, AND RELATIVELY EASY TO CONSTRUCT.

THE FIRST POINT TO CONSIDER THEREFORE IS THE SHORTING PLATE, WHICH SERVES TO SUPPORT THE ELEMENTS, AS WELL AS, PROVIDE A ZERO AC IMPEDANCE TO RF ENERGY FLOWING BETWEEN THE ANTENNA ELEMENTS. THE WIDTH OF THIS PLATE SHOULD BE ABOUT 0.05 TO 0.15 WAVELENGTHS. SINCE THIS PLATE IS A ZERO POTENTIAL POINT, NO INSULATORS ARE NECESSARY WHEN MOUNTING.

NEXT THE SPACING BETWEEN THE ELEMENTS IS CALCULATED BY THE RATIO B/A , WHERE B = THE RADIUS AND A = THE DISTANCE BETWEEN THE ELEMENTS. B AND A MUST BE EXPRESSED IN THE SAME UNITS. A VALUE OF 16 HAS BEEN FOUND A SATISFACTORY VALUE FOR THIS RATIO.

THE LENGTH OF THE LONG ELEMENT IS APPROXIMATELY EQUAL TO 0.71 LAMBDA AND THE SHORTER ELEMENT LENGTH APPROXIMATELY EQUALS 0.24 LAMBDA.

THE ANTENNA DESCRIBED ABOVE AND SHOWN IN FIGURE 25 IS

DESIGNED TO BE FED WITH A 200 OHM BALANCED LINE, WHICH IS EASILY CONSTRUCTED FROM AN ELECTRICAL 1/2 WAVELENGTH OF 50 OHM COAXIAL CABLE. TO MATCH THE ANTENNA TO THE FEEDLINE SLIDE THE FEEDPOINTS UNTIL A LOW SWR IS OBTAINED. FINAL FEEDPOINT LOCATION SHOULD BE BETWEEN 0.024 AND 0.048 WAVELENGTHS FROM THE SHORTING PLATE.

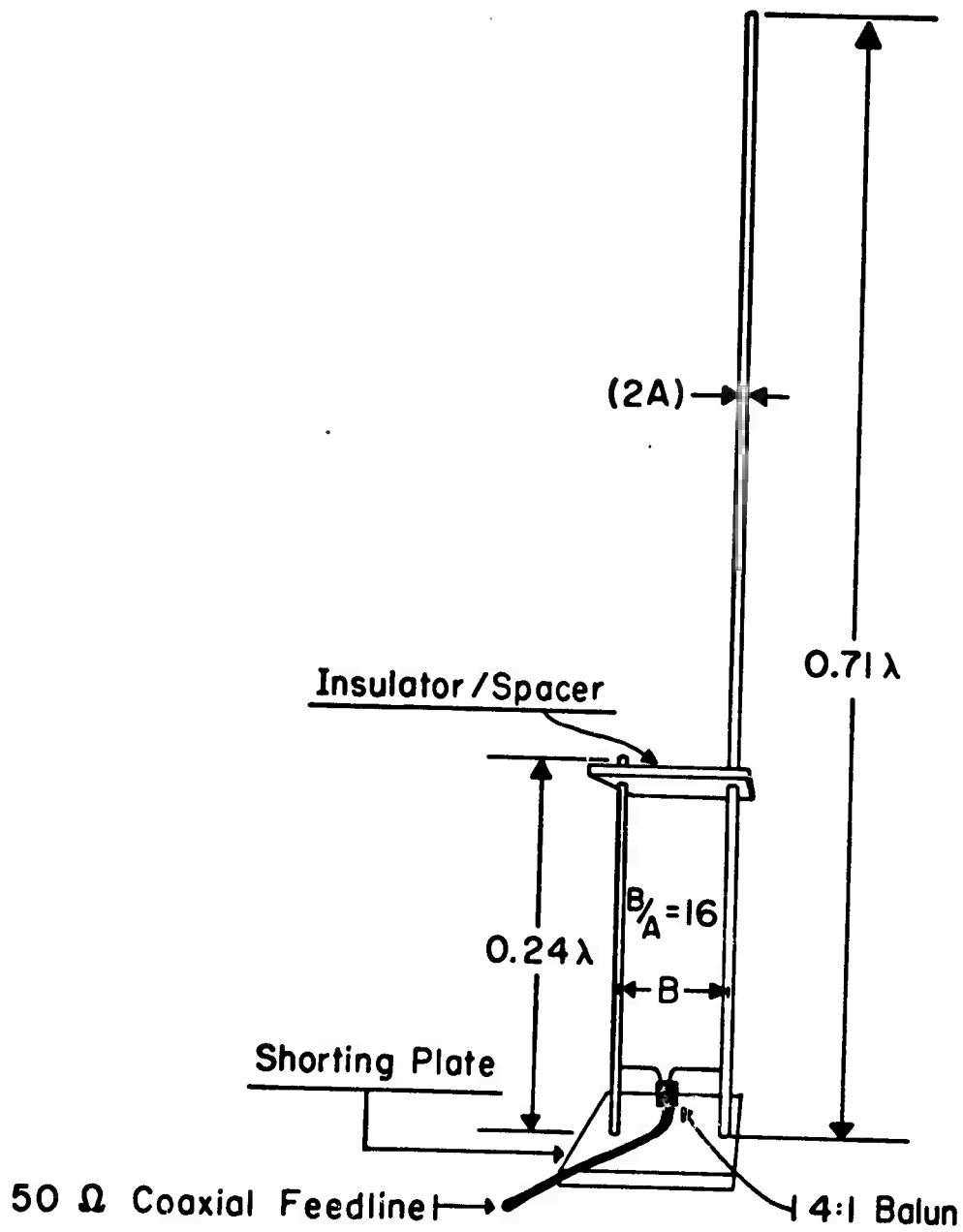

Figure 26
 BALANCED HYBRID DIPOLE

B. THE UNBALANCED HYBRID

THIS ANTENNA LENDS ITSELF TO VHF AND UHF MOBILE APPLICATION, AND TEST ANTENNAS CONSTRUCTED WITH 1/4 INCH STAINLESS STEEL RODS HAVE PROVEN VIRTUALLY INDESTRUCTABLE.

THE BASE OF THE ANTENNA ACCEPTS THE COAXIAL CHASSIS MOUNT CONNECTOR, AND THE SAME MOUNTING SCREWS WHICH ATTACH THE CONNECTOR ALSO SECURE THE STRAIN RELIEVER.

IN THIS MODE OF OPERATION THE WIDTH OF THE ANTENNA BASE IS NOT CRITICAL, IT MUST OF COURSE BE WIDE ENOUGH TO PROPERLY MOUNT THE CONNECTOR.

ELEMENT SPACING IS DETERMINED BY WAVELENGTH, AND, FROM EXPERIMENTAL DATA, SHOULD BE BETWEEN 0.025 AND 0.031 WAVELENGTHS. THIS MAINTAINS THE PHASE RELATIONSHIP NECESSARY FOR CANCELLATION OF UNWANTED RADIATION WHILE KEEPING THE IMPEDANCE CLOSE TO 50 OHMS.

ELEMENT LENGTH HAS PROVEN TO BE APPROXIMATELY 0.7 AND 0.23 WAVELENGTHS FOR THE LONG AND SHORT ELEMENTS RESPECTIVELY. THESE LENGTHS HAVE BEEN DERIVED FOR INSTALLATIONS IN WHICH THE ANTENNA IS TO BE MOUNTED ABOVE A VEHICLE ROOF.

EXTRA STRENGTH MAY BE OBTAINED BY PLACING A STRONG ROD MADE OF INSULATING MATERIAL BETWEEN THE ELEMENTS, THROUGH

THE INSULATING SPACERS AND SECURING IT IN THE ANTENNA BASE.
THIS INCREASES THE COMPLEXITY OF THE ANTENNA BUT WITH
FLEXIBLE ELEMENTS MAY PROVE INVALUABLE.

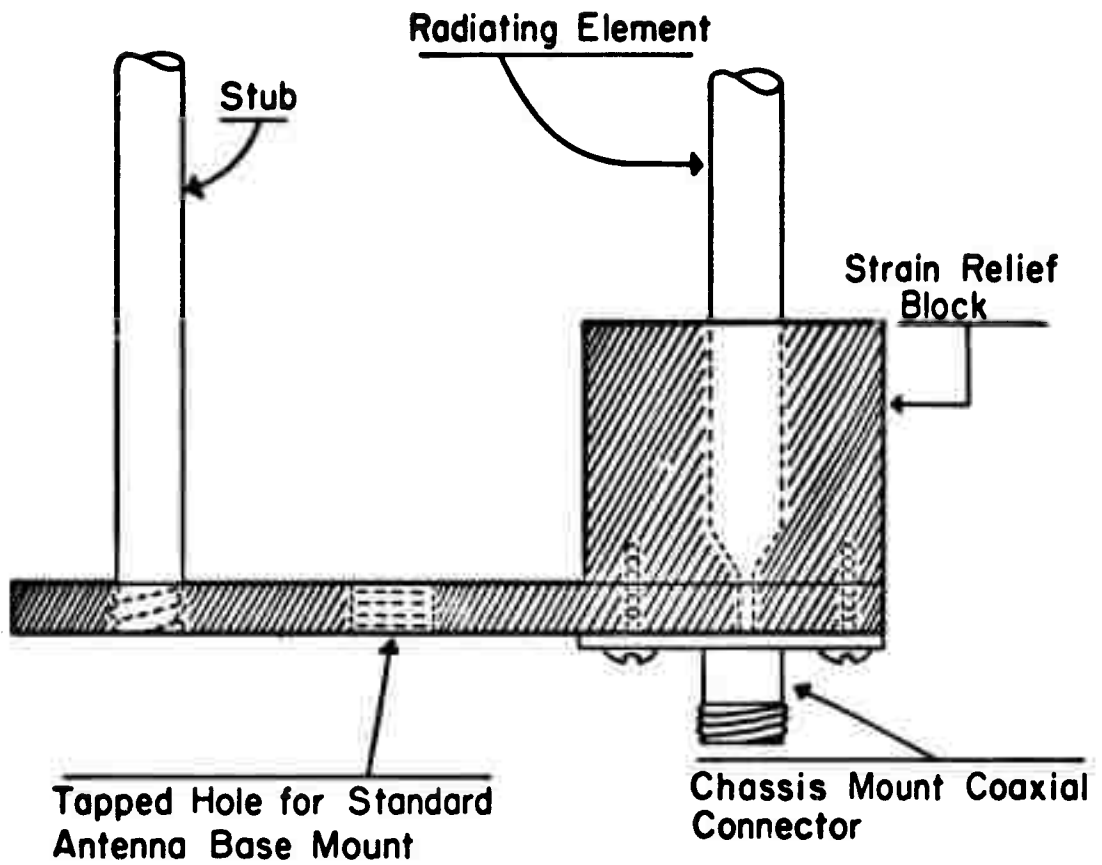

Figure 27

CONSTRUCTION DETAILS UNBALANCED
HYBRID DIPOLE.

LIST OF REFERENCES

1. PRIVATE COMMUNICATION WITH DR. JOHN ROCKWAY,
NAVAL ELECTRONICS LABORATORY CENTER, SAN DIEGO, CA
2. MINNIS, T. "TESTING ROOF MOUNTED WHIP ANTENNAS",
73 MAGAZINE, VOL. 152, PP. 39-42, MAY 1973.
3. KING, R.W.P., MINNO, H.R., AND WING, A.H.,
TRANSMISSION LINES, ANTENNAS AND WAVE GUIDES, CH. 10,
MCGRAW HILL PUBLISHING CO., INC., NEW YORK, N.Y., 1945