

AD-776 011

JOINT EXPERIMENT ON THE SPECTRUM OF  
EARTHQUAKE SOURCES-LONG-PERIOD  
INSTRUMENTATION

Stephen D. Malone

Washington University

Prepared for:

Air Force Office of Scientific Research  
Advanced Research Projects Agency

27 December 1973

DISTRIBUTED BY:

**NTIS**

National Technical Information Service  
U. S. DEPARTMENT OF COMMERCE  
5285 Port Royal Road, Springfield Va. 22151

UNIVERSITY OF WASHINGTON  
SEATTLE, WASHINGTON 98195

Graduate Program in Geophysics

Form Approved  
Budget Bureau No. 22-R0293

Annual Technical Report: 1 November 1972 - 31 March, 1973

ARPA Order No. 2134

Program Code No. F10

Name of Contractor: Geophysics Program, University of Washington

Grant Period: 1 April 1972 - 31 March 1973

Amount of Grant: \$96,877

Grant No. AFOSR 72-2304

Principal Investigator: Stewart W. Smith - 206-543-8021

Short Title: "Joint Experiment on the Spectrum of Earthquake Sources -  
Long-Period Instrumentation"

Report Prepared by: Stephen D. Malone

Sponsored by: Advanced Research Projects Agency - ARPA Order No. 2134

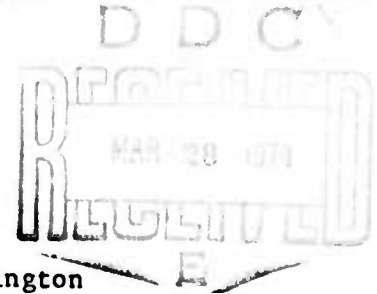

1. Research Program

This grant covers the construction and operation of a set of three three-component long-period telemetry stations to be operated in conjunction with other instrumentation of the "Joint Experiment on the Spectrum of Earthquake Sources". The purpose of this experiment is to obtain reliable high quality long-period records of small to medium sized earthquakes to determine the effectiveness of long-period discriminants in the limit of small events. This report covers the final testing, installation, and operation of the instruments in the field near Bear Valley California. A detailed manual for the construction and operation of the digital long-period electronics is included in the appendix.

2. Technical Report Summary

During this report period, three long-period FSK stations were installed in the Bear Valley area of California. The stations are at a distance

Reproduced by  
NATIONAL TECHNICAL  
INFORMATION SERVICE  
U S Department of Commerce  
Springfield VA 22151

DISTRIBUTION STATEMENT A

Approved for public release  
Distribution Unlimited

AD 7 6 0 1 1

## DOCUMENT CONTROL DATA - R &amp; D

(Security classification of title, body of abstract and indexing annotation must be entered when the overall report is classified)

1. ORIGINATING ACTIVITY (Corporate author) University of Washington Geophysics Department Seattle, WA 98195		2a. REPORT SECURITY CLASSIFICATION UNCLASSIFIED	
		2b. GROUP	
3. REPORT TITLE Joint Experiment on the Spectrum of Earthquake Sources - Long Period Instrumentation			
4. DESCRIPTIVE NOTES (Type of report and inclusive dates) Scientific.....Interim Annual Tech Report 1 Nov 72 - 31 Mar 73			
5. AUTHOR(S) (First name, middle initial, last name) Stephen D. Malone			
6. REPORT DATE 27 Dec 73		7a. TOTAL NO. OF PAGES 49	7b. NO. OF REFS 0
8a. CONTRACT OR GRANT NO. AFOSR-72-2304		9a. ORIGINATOR'S REPORT NUMBER(S)	
b. PROJECT NO. AO 2134			
c. 62701E		9b. OTHER REPORT NO(S) (Any other numbers that may be assigned this report) AFOSR - TR - 74 - 0251	
10. DISTRIBUTION STATEMENT Approved for public release; distribution unlimited.			
11. SUPPLEMENTARY NOTES TECH, OTHER		12. SPONSORING MILITARY ACTIVITY AF Office of Scientific Research/NP 1400 Wilson Boulevard Arlington, VA 22209	
13. ABSTRACT During this report period 3 long period FSK stations were installed in the Bear Valley area of California. The stations are at a distance of 30 to 45 km from the expected epicenters of small to medium sized earthquakes in Bear Valley. Two stations are located in shallow vaults on the west side of the Diablo Range. The third station is in a short mine adit on the east side of this mountain range. Problems were encountered in the construction and initial operation of these stations due mainly to the weather. The large amount of rain fall this past winter in central California slowed construction procedures considerably and once the stations were operating, tilting due to wet soil conditions caused instrument instabilities. The first few months of operation saw instrument failures more often than was hoped for. Problems with electronic and communication links were minimal and all had been corrected by the end of this reporting period. Data collected during first few months of operation contained no earthquakes of interest from the Bear Valley area. The only well recorded regional event was the Point Magu earthquake of 21 Feb 73. Calibration of each station indicates that all instruments are operating within 3% of the response curve given in Figure 3.			

of 30 to 45 km. from the expected epicenters of small to medium sized earthquakes in Bear Valley. Two stations are located in shallow vaults on the west side of the Diablo Range. The third station is in a short mine adit on the east side of this mountain range. Problems were encountered in the construction and initial operation of these stations due mainly to the weather. The large amount of rain fall received this past winter in central California slowed the construction procedures considerably and once the stations were operating, tilting due to the wet soil conditions caused instrument instabilities. The first few months of operation saw instrument failures more often than was hoped for. Problems with the electronics and communication links were minimal and all had been corrected by the end of this reporting period.

The data collected during the first few months of operation contained no earthquakes of interest from the Bear Valley area. The only well recorded regional event was the Point Magu earthquake of February 21, 1973. Calibration of each station indicates that all instruments are operating within 3% of the response curve given in figure 3.

### 3. Location and Construction of Field Installations

#### A. Station Locations

Beginning in November, 1972, trips were made to the field area near Bear Valley, California to locate and build three seismic vaults to house the instruments being built at the University of Washington. Table 1 gives the pertinent information on these three station locations and figure 1 is a map showing both the University of Washington stations and the University of Nevada stations relative to the expected Bear Valley epicentral area.

The sites were chosen with a number of criteria in mind. 1. The azimuthal distribution was constrained to fall roughly around half a circle centered on the Bear Valley fire station. 2. The distance from the center was constrained to be within 25 to 45 kilometers. 3. Bedrock sites were chosen to minimize local noise sources and signal attenuation. 4. Terrain of moderate relief (slope less than 8 degrees) was sought to lessen the

problem of instrument tilt due to unstable ground. 5. Communication links (radio or telephone) had to be available close by for telemetry of the seismic signal to the central recording site in Hollister, California. 6. Commercial power available locally was a desired criteria though not imperative since the field electronics including radio transmitter only use about 10 watts of power and batteries could be used.

Criteria 3 and 4 above were somewhat mutually exclusive since the flat areas are generally valley bottoms with no bed rock and hills are competent rock. A compromise solution was used by placing the vaults near the valley-hill contact on bed rock where the hill slope was a minimum. Two of the stations (EHC and QSC) are located on the west side of the Diablo Range in shallow holes. The third station (LGM) is located in a short (about 50 ft.) mine adit in a small canyon on the east side of the Diablo Range. Commercial power was available at each site within 400 yards. The data as telemetered by radio from each site locating the transmitter on the top of a nearby rise. The two west side stations transmit directly to the recording site at the Hollister Airport. The LGM station transmits about five miles to a telephone pole where the signal is received and sent over phone lines the 50 miles to Hollister.

#### B. Installation Details

The two stations west of the Diablo range (EHC and QSC) were constructed in an identical manner. A backhoe was used to dig a hole about 6 feet deep by 4 feet square. In both cases this depth was as deep as the backhoe could go because of the increase in the strength of the rock. It is not known if this harder layer is actually bed rock or an intermediate layer between the surface soil and bed rock. A 6 inch concrete pad was pored in the bottom of the hole and a 4 feet long by 3 feet in diameter aluminum culvert section was stood on end in the concrete. By placing an aluminum plate over the top of the culvert a vault was formed to house the seismometers and electronics. The concrete was sealed with a water sealer and the seams in the culvert were caulked to prevent water from entering the vault from the bottom or sides. To isolate the seismometers from barometric pressure changes, a 1/4 inch thick steel tank was

cemented into the floor of the vaults. A hemispheric domed top is bolted onto the tank to form an air tight seal. The electronics package is suspended in a water tight box from the side of the vault. To isolate the seismometers from temperature changes, a number of layers of insulation are used. Inside the tanks styrofoam blocks surround each seismometer. Three inch thick fiber glass house insulation is layered over the outside of the tank. Bags of styrofoam chips fill up the rest of the air space in the vault to minimize air circulation. After the vault is closed, it is covered with one to two feet of dirt or gravel. It takes about one-half hour to gain access to the instruments starting from a closed and covered vault.

The LGM station is located in a short abandoned mine adit. The construction procedures were far simpler. A place in the floor of the back of the mine was cleared of all loose rock and dirt. A small concrete pad was poured to set the pressure tank into. Fiberglass insulation was placed over the tank and a thick insulated wooden door was placed on the entrance.

#### C. Construction Problems

The complete station installation was delayed considerably over the expected time. The original estimate for beginning operations was December 1, 1972. The first station did not go on the air until January 23, 1973. The largest obstacle was the weather. This past winter has been the wettest winter of this century in central California. The persistent rains made construction very difficult. Even getting to one of the stations was increasingly difficult because of the mud. Once the vaults were in, operation was delayed because time was needed for the tanks to dry thoroughly such that the seismometer would not be installed in a wet environment. Problems with the communication links and tape recorder further delayed operations a week or two. The LGM station did not begin operation until February 26, 1973 because the telephone line was slow in being connected.

#### 4. Array Operation and Data

##### A. Operation and Problems

The data from the University of Washington stations and the University of Nevada stations are recorded together on a seven track tape recorder with a WWVB time signal at a speed of 15/16 ips. The recorder is located in a small room in the hanger of the San Benito Air Service at the Hollister Airport. Personnel at the airport change the tape and visual monitor record daily. The paper records are sent to the University of Washington every few days to enable us to detect technical problems as soon as possible. The tapes are erased and recycled after about two weeks if there is nothing of interest to save. If an event occurs which is of potential interest, the appropriate tape is sent to the University of Washington campus where it is played back through the computer interface to produce a computer compatible digital tape. Paper records are then made from this data of each seismic component. Digital tape of interesting events can then be sent to the University of Nevada and other interested parties.

##### B. Testing

Once the instruments were installed and operating, they were thoroughly tested and calibrated. A frequency response curve was run at the 15 sec free period and is shown in figure 3. The difference between this curve and the one shown in the last technical report is due to the change in the pendulum free period. A calibration pulse was applied to each instrument by means of an electrical current in the calibration coil. The final output pulses throughout the entire system were compared to make sure the shape and height of each was the same. A problem with the gain ranging logic on the LGM station was not detected until the end of this reporting period. The final testing indicated that all instruments have a response within 3% of the curve shown in figure 3.

Table 2 gives a status report of the operating stations over the period January 23 - March 31 for the three stations operated by the University of Washington. The data during this time period is not of the highest quality

because of small technical problems in the recording and playback electronics. The frequency response of the tape system operating at 15/16 ips is such that the FSK tones are distorted slightly. The read unit could only read the data marginally. Figure 2 shows an example of the data from two stations; one which the electronics were properly equalized and one for which they were not. This problem had been corrected by the end of this report period.

The most serious problem encountered during the initial period of operation was the tilting of the horizontal seismometers. We feel that the wet weather conditions of this winter contributed greatly to this problem. The horizontal seismometer pendulum was originally set at a free period of 20 sec. It was then observed during the wet season that the center position of the boom could drift as much as 1 mm per day. With the periods readjusted to 15 sec, the center position drift decreased to about 1 mm per week. We feel that a large part of the initial instability was due to the consolidation of the soil around the vaults. Because of the high drift rate and the difficulty in recentering (which required a trip from Seattle to the Hollister area) some instruments had a higher than expected down time. The great difficulty in keeping the horizontal seismometers near center has made the initial operating time disappointing. It is hoped that after an initial settling period and with more stable weather conditions, the drift problem will be greatly reduced.

#### C. Data

During the first two months of operation there were no earthquakes in the Bear Valley region large enough to be noticeable on the long-period array. The only regional event of interest was the Point Magu earthquake of February 21, 1973,  $M_L$  6.0. It was recorded on only three of the six instruments operating at that time because of the problem of instrument centering. Figure 4 shows these three seismograms low-pass filtered and decimated by 3. The P, S and surface waves can be easily identified on each seismogram. Figure 5 shows the displacement amplitude density spectra corrected for instrument response for the S wave portion of each seismogram. These spectra may be contaminated by

the first part of the surface wave train. A corner frequency around .3 - .4 hz. can be clearly identified on each spectrum and the long-period flat portion of the spectra are at about 200 - 300 $\mu$  - sec. This event was a good test of the gain ranging ability of the FSK system. One step of gain ranging was used on this event though the point at which it occurs cannot be detected by examining the records, even closely.

Figure 6 shows the power density spectra of the seismic background noise on horizontal and vertical component instruments at QSC. The data for these spectra were taken from a period in February when the 6-second microseisms were quite large due to winter storms in the Pacific. The spectral peaks around 6 seconds are much larger in these samples than they were at Longmire, Washington in November; however, the minima at longer periods (10-20 seconds) are lower in at QSC indicating that the thermal and pressure isolation is reducing the long-period noise.

A few teleseisms were recorded during this period and the instruments responded as expected. By the use of teleseisms it is hoped that a crude amplification or attenuation factor for each site can be calculated. Differences in ground motion amplitude have been noticed at different stations; however, the data is not extensive enough yet to discuss these differences quantitatively.

##### 5. Work in Progress

During this report period, the three long-period station electronics have been completed and the stations installed in the Bear Valley area. Initial problems with the data quality have been worked out. Recording on a routine basis has begun such that the array is ready for the expected Bear Valley earthquakes. Problems with instrument drift have been observed; however, it is anticipated that these problems will be minimized as the soil around the stations stabilizes after the rainy season.

TABLE 1  
Station Locations

Code	Name	Location	Rock Type	tape chan	start date
EHC	East hollister	36 55.01 121 19.50	Miocene volcanic & Upper Cretaceous Marine	1	Jan. 23
QSC	Quien Sabe Ranch	36 48.62 121 09.79	Miocen Volcanics	2	Jan. 22
LGM	Lee Grant Mine	36 33.60 120 49.90	Upper Cretaceous Marine & Plio-Pleistocene nonmarine	3	Feb. 27

Table 2  
Station Operating Conditions 1st Quarter 1973  
(number of components operating)

Jan.	22	23	24	25	26	27	28	29	30	31	1	2	3	4	5	6	7	8	9	10	11	12	13	14	15
EHC	-	3	3	3	3	3	3	3	3	3	3	3	3	3	3	3	3	3	1	1	1	1	2	2	2
QSC	3	3	3	3	3	3	3	3	3	3	3	3	3	3	3	3	3	3	3	3	3	3	3	3	3
LGM	-	-	-	-	-	-	-	-	-	-	-	-	-	-	-	-	-	-	-	-	-	-	-	-	-

Feb.	16	17	18	19	20	21	22	23	24	25	26	27	28	1	2	3	4	5	6	7	8	9	10	11	12
EHC	2	2	2	1	1	1	1	1	1	1	1	3	3	3	3	3	3	3	3	3	3	3	3	3	3
QSC	3	2	2	2	2	2	2	2	1	1	1	3	3	3	3	3	3	3	3	3	3	3	3	3	3
LGM	-	-	-	-	-	-	-	-	-	-	-	3	3	3	3	3	3	3	3	3	3	3	3	3	3

March	13	14	15	16	17	18	19	20	21	22	23	24	25	26	27	28	29	30	31
EHC	3	3	3	3	3	3	3	3	3	3	3	3	3	3	3	3	3	3	3
QSC	3	-	-	3	-	3	3	3	3	3	3	3	3	3	3	3	3	3	3
LGM	3	-	-	-	3	3	3	3	3	3	3	3	3	3	3	3	3	3	3

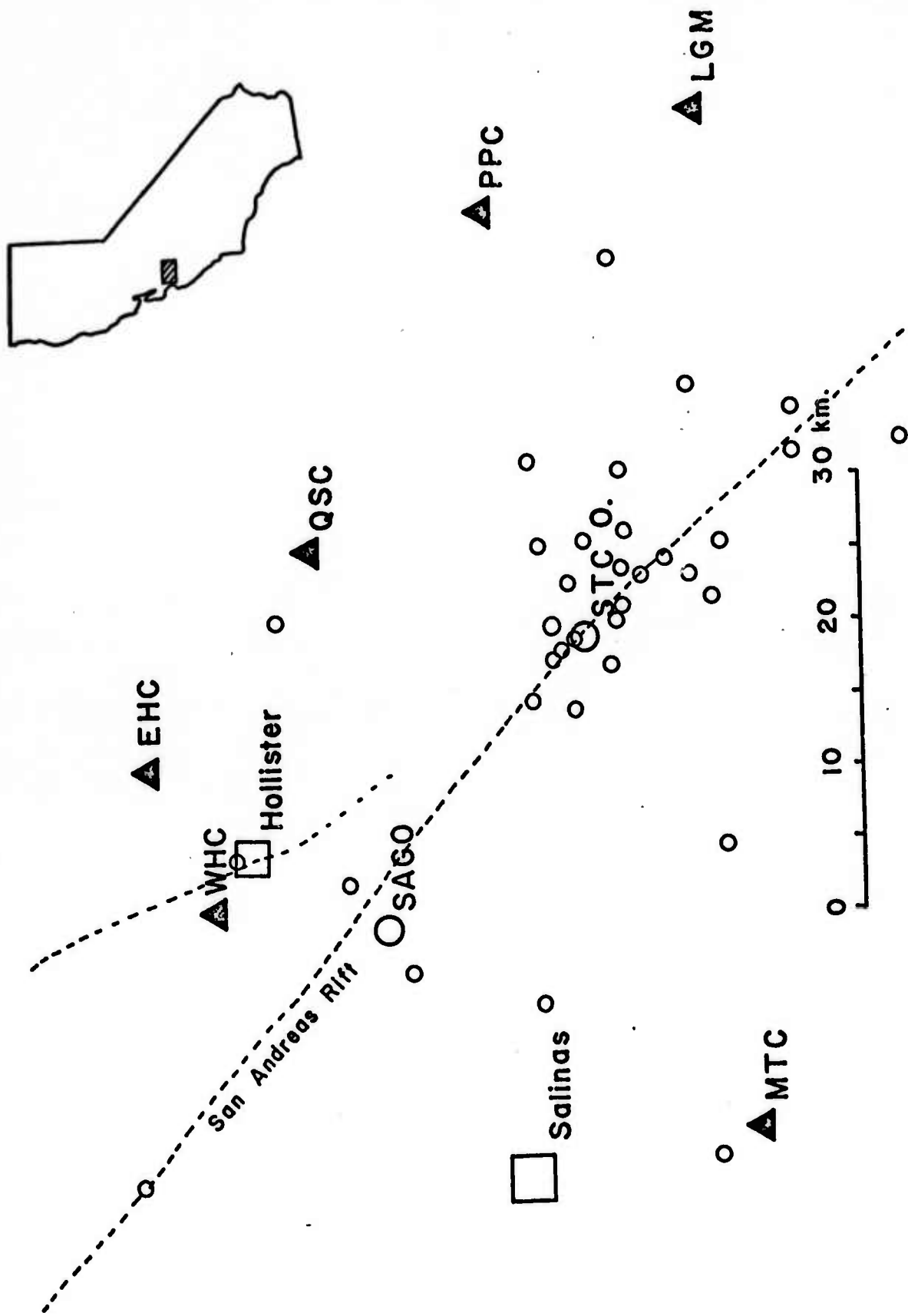

Figure 1.

REGIONAL EVENT (7/5/73 1300Z WASH EHC, LGM  
 BUFL: 700  
 NCH: 7  
 PERIOD: 91  
 TIME SCALE: 1  
 AMP FACTORS: .02 .02 .02 .01 .01 .01  
 MEAN OF FIRST RECORD OF CHANNEL  
 1 . -98

14  
 14  
 21  
 42  
 140

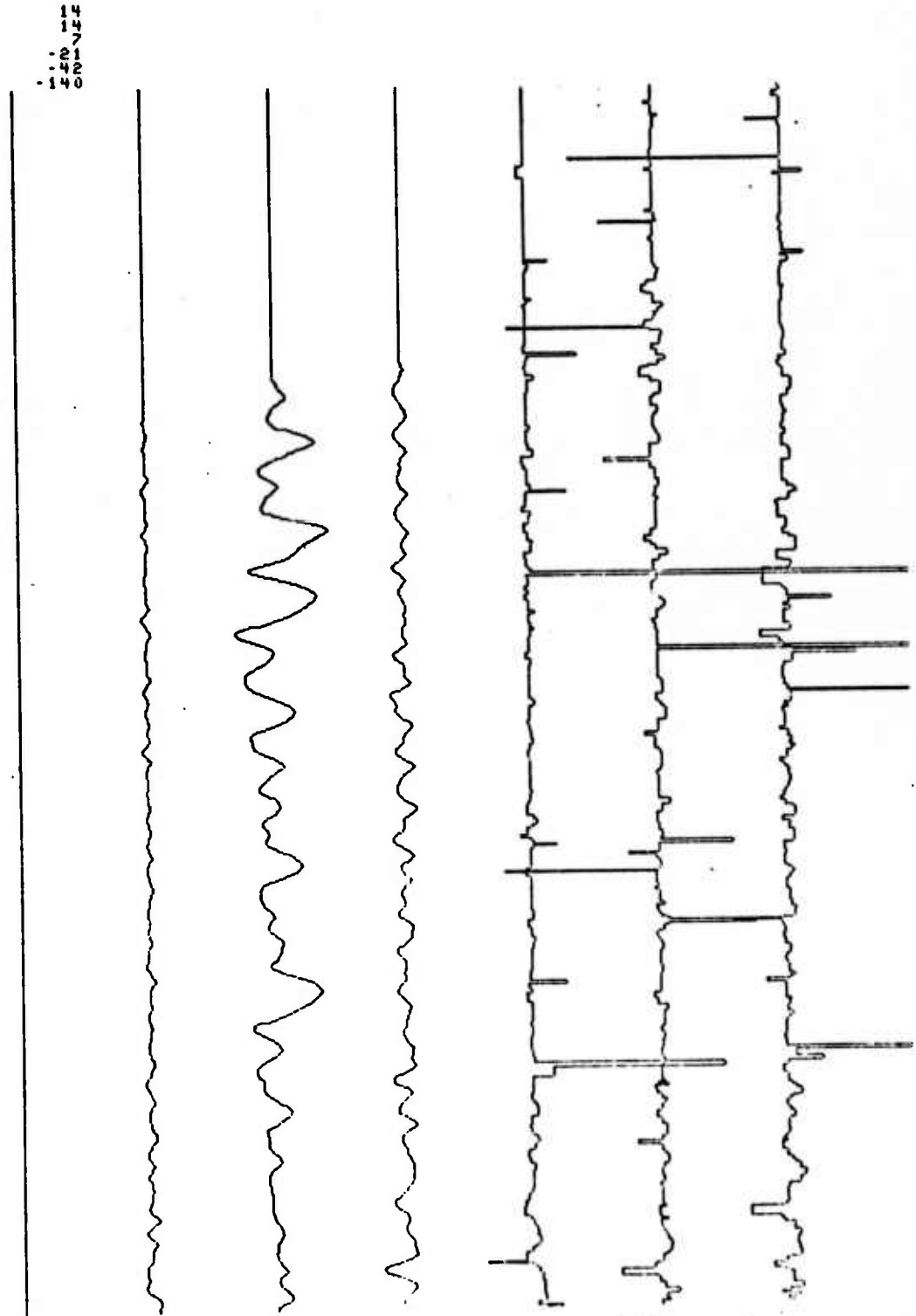

Figure 2.

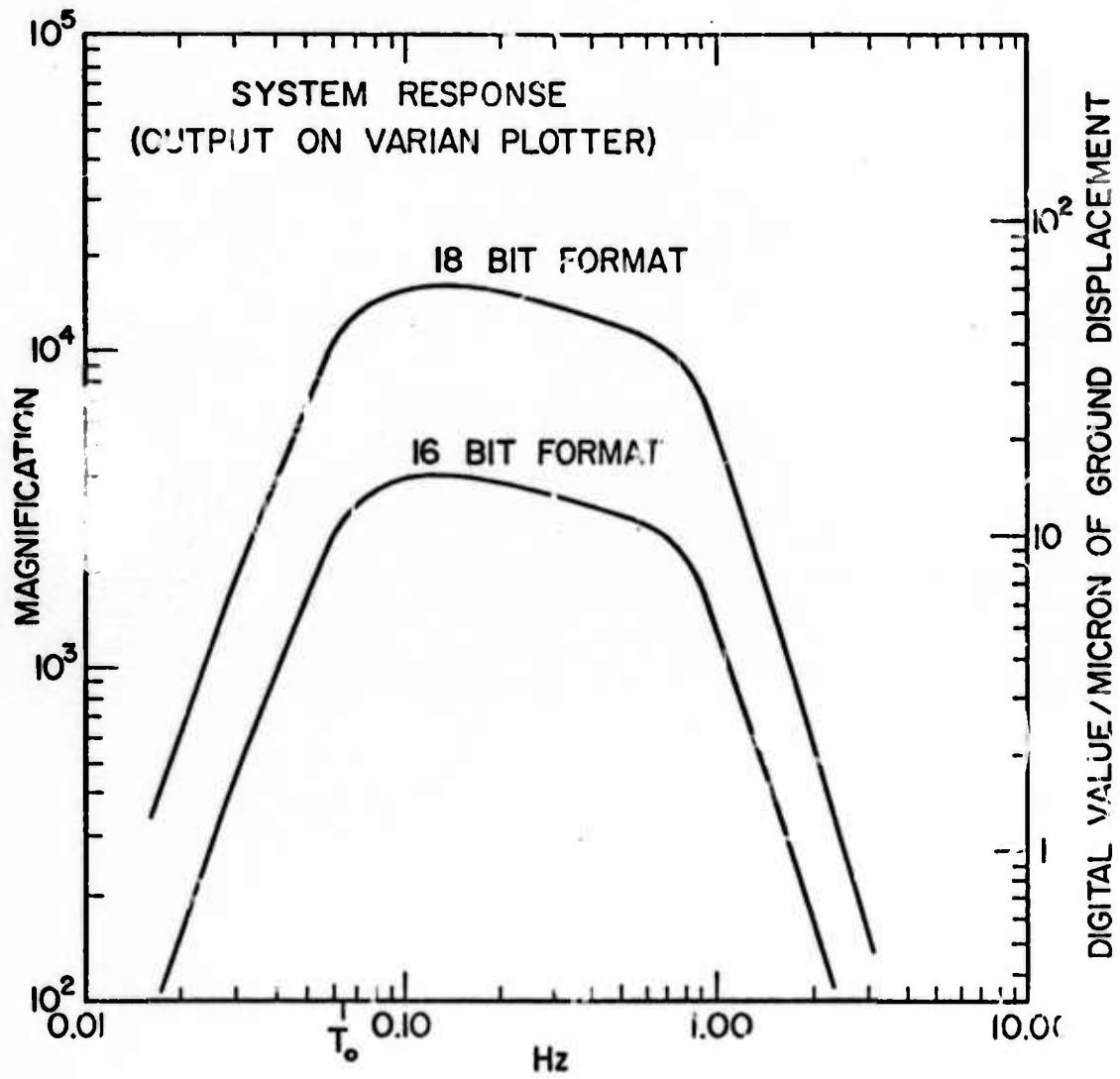

Figure 3.

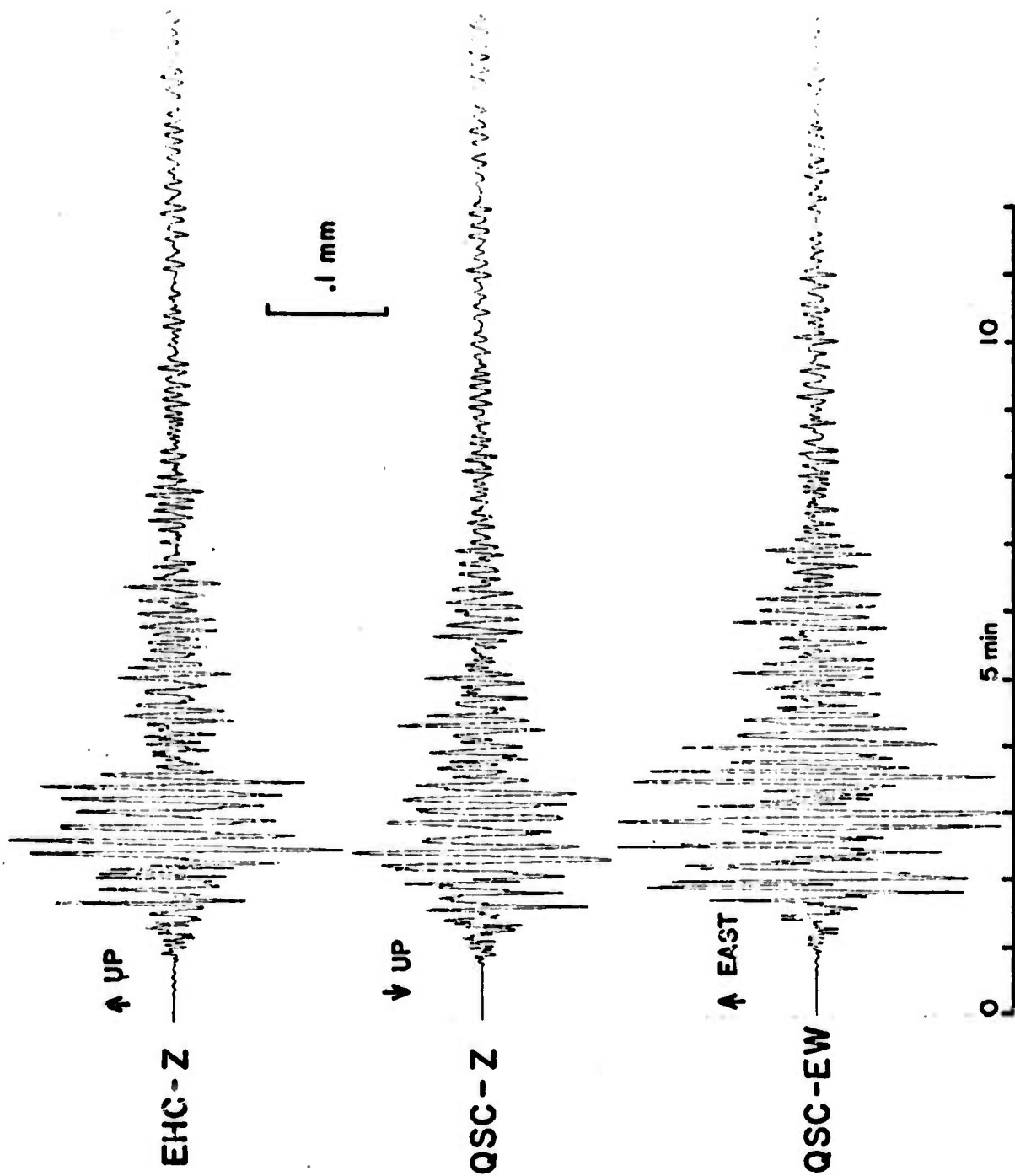

Figure 4.

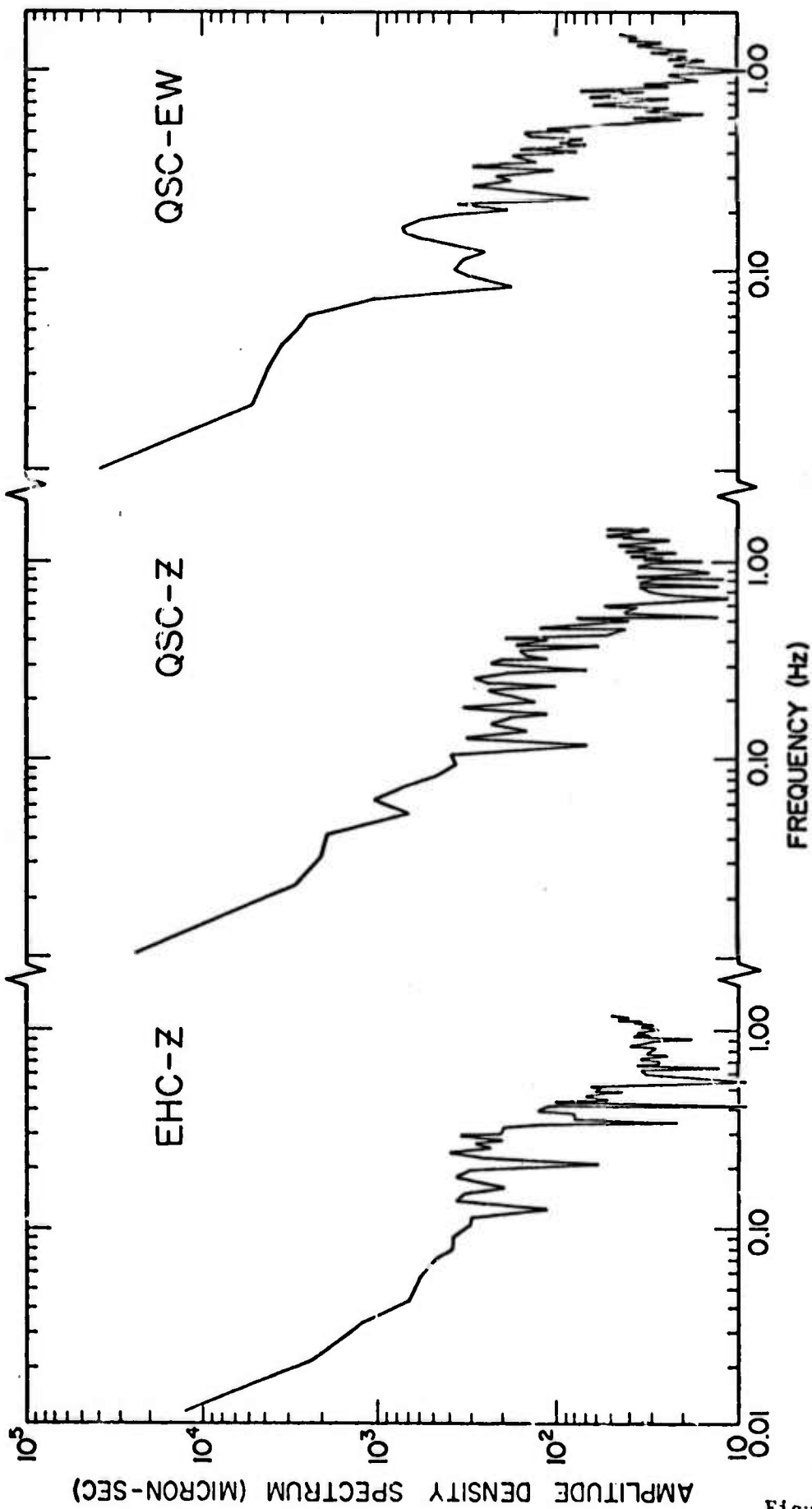

Figure 5.

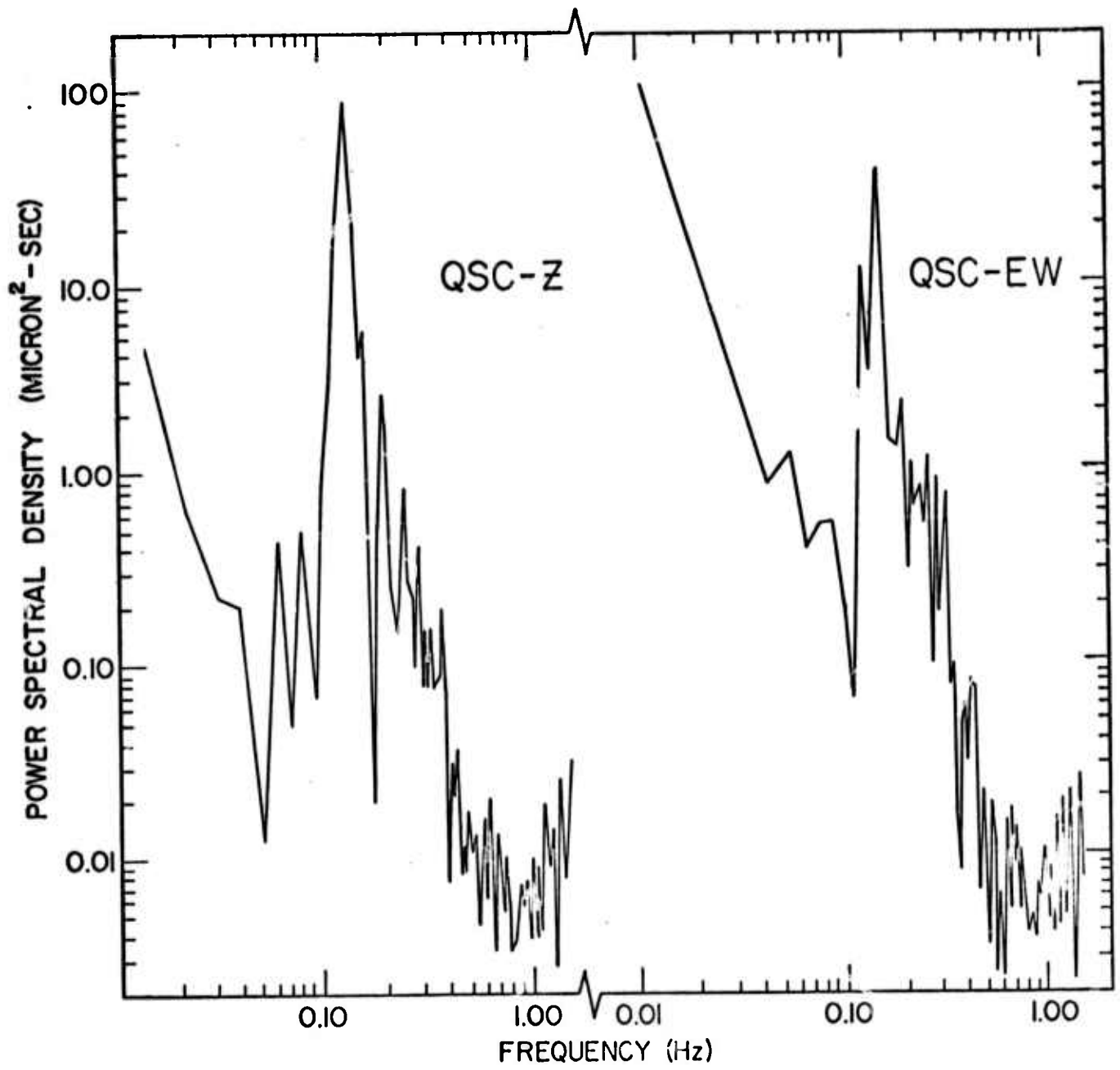

Figure 6.

## APPENDIX

### Long-Period Digital FSK Seismic Telemetry System

This equipment was designed and built at the Geophysics Program, University of Washington, Seattle, Washington 98195

Head Engineer: Rex V. Johnson, Electrical Engineer, Geophysics Program, University of Washington

Consulting Engineer: Henry LaHore, Electrical Engineer, Department of Atmospheric Sciences, University of Washington

Project Coordinators: Stephen D. Malone, Senior Research Associate  
Stewart W. Smith, Program Chairman  
Geophysics Program, University of Washington

This research equipment design and construction was supported by the Advanced Research Projects Agency of the Department of Defense and was monitored by the Air Force Office of Scientific Research under Grant No. AFOSR-72-2304.

## CONTENTS

I.	General Description . . . . .	1
A.	Purpose of Equipment . . . . .	1
B.	Description of Equipment . . . . .	1
C.	Specifications . . . . .	2
II.	Installation and Operating Procedures . . . . .	3
A.	Connections . . . . .	3
B.	Balancing Procedures . . . . .	3
C.	Field Adjustments . . . . .	4
D.	Electronics Rack . . . . .	5
III.	Theory of Operation . . . . .	6
A.	Overall System . . . . .	6
B.	Preamp Board . . . . .	6
C.	Filter Board . . . . .	8
D.	Sample and Hold Board . . . . .	9
E.	Control Logic Board . . . . .	9
F.	Analog to Digital Converter Board . . . . .	14
G.	Larse Communicator Board . . . . .	15
H.	Input-Output Board . . . . .	16
I.	Power Supply Boards . . . . .	16
IV.	Trouble Shooting . . . . .	16
V.	Wiring Diagrams and Schematics . . . . .	18
VI.	Parts Lists . . . . .	30

## I. GENERAL DESCRIPTION

### A. Purpose of Equipment

The FSK Long-Period System is to be used in an array of long-period stations surrounding at distances of 35 to 45 km., the expected epicenters of small to medium sized earthquakes. The data collected using this equipment will be used to study the fundamental source characteristics of small earthquakes. To reliably, and with high precision, record such earthquakes the FSK system is designed to have a large dynamic range and be quite linear. The telemetering of the seismic data is important to minimize operational difficulties of local recording. The FSK (Frequency Shift Keyed) output of this system can be sent over any conventional telemetry link.

### B. Description of Equipment

The FSK Long-Period System is enclosed in a water tight box with four connectors; three for the seismometer inputs and one for the power in and signal out. The input impedance is adjustable to match the seismometer damping resistance. Highly linear, low noise amplifiers and filters shape the signal to the desired band. A gain ranging scheme allows the 12 bit digital word plus two gain ranging bits to give the system an overall dynamic range of 106db. Conversion of the parallel digital data into serial FSK tones is done by a commercially available communicator module. Three channels of seismic data are multiplexed onto one data channel. Each seismic channel is sampled 11 times per second, meaning the output channel carries 33 words per second or 528 bits per second. The entire system operates on 7.2 watts, meaning that battery operation is feasible where commercial power is not available.

### C. Specifications

---

Input Impedence	$\sim 10k\Omega$ (adjustable to seismometer)
Filters (low pass Bessel)	
1st corner	0.05 Hz at 6 db/oct.
2nd corner	1.0 Hz at 24 db/oct.
Total below 1 Hz	30 db/oct.
Gain Ranges	
Maximum	12,800 (83.6 db)
Middle	1,600 (64.8 db)
Minimum	200 (46.0 db)
Total Dynamic Range	106 db
Linearity	.01%
Input Signal Range	$\pm 50$ mv
Sample Rate	11/sec./channel
System Noise Relative to Input	0.1 $\mu$ v rms (ground displacement equivalent .04 microns)
System Bandwidth	1 Hz
Output	
Impedence	600 $\Omega$ isolated
Level	-40 to 0 dbm
FSK Frequencies	1200 and 2400 Hz
System Power	
Input Voltage	+20 to +28 volts
Input Current at 28v	0.3A
Input Power at 28v	7.2 watts
Physical Demensions	24" x 12" x 6"
Weight	28 lbs.
Package	Water Tight

## II. INSTALLATION AND OPERATING PROCEDURES

### A. Connections

General outline for getting FSK Communicator in operation:

1. Connect seismometers to input 1, 2, & 3:

Connectors #1 thru #3	Pin A - Ground
Pin Assignments	Pin B - Negative Input -
	Pin C - Positive input +
	Pin D - No connection

2. Each preamplifier input impedance can be changed to give the desired loading to each seismometer. If this is necessary, refer to detailed wiring diagram of preamplifier and change  $R_1$  and  $R_2$ .
3. Connect system output to radio link or phone line and +24v. d.c. to input #4.

Connector #4 Pin	Pin A - +24 volts d.c.
Assignments	Pin B FSK output
	Pin C Full floating
	Pin D - Power Ground

NOTE: Also connect the metal enclosure to an earth ground on installation in the field.

4. Balance the entire system, first in a lab and also in the field on installation.

### B. Balancing Procedure

This procedure is to provide a zero output on all three multiplexed signals when their inputs are zero. When performed correctly, a zero input signal level will correspond to the 0 level on the A to D connector  $\pm$  LSB which is  $\pm$  5mv, after a gain of 12,800.

All units should be balanced in a lab type environment before being taken to the field. There are 3 sets of trim pots on the unit with the following adjustment ranges:

<u>Trim pot</u>	<u>Location</u>	<u>Total Range</u>
Preamp	RA 1 thru 3	4 volts
Filter	RF 1 thru 3	100 mv
S & H	RS 1 thru 3	varying

Lab Balancing, S & H Balance (electronic rack must be out of enclosure). The inputs to each preamp should be shorted together. System should be on and warmed up for 5 to 10 minutes. Connect a scope to the output of S & H board #3, pin S3 - 12. Tie the input of the S & H boards to ground, pin S1 - 3 to S3 - 4. Adjust RS-3 to zero d.c. level on scope. Move scope to S & H board #2, pin S2 - 12, adjust RS-2 for zero and repeat for S & H board #1, pin S1 - 12; adjust RS-1. After all three S & H boards are adjusted to zero, remove the short between S1 - 3 to S3 - 4. Normally, this adjustment need only be done in the lab and not in the field.

Preamp and filter balance (electronic in enclosure). Again each preamp input should be shorted together.

1. Scope Method: Trigger the scope with a logic pulse from the logic board, pin HA4. Take care not to short the wire-wrap pins together. The signal to be balanced can be observed at the input to the A to D, pin AD-18 or on the board itself. There are two resistors mounted on small standoffs on the outer edge of the board near the middle. Clip to the standoff that gives the largest signal (d.c.) level. Signal ground can be obtained from any ground pin on the logic board. The ground pins are soldered on the bottom (pin) side. When the signal is in sync, on about a 5 msec (div time scale) you will see 3 time shared d.c. levels. Adjust RA 1 thru 3 until each d.c. level is within about  $\pm 50$  mv of zero. Then do a fine adjust with the filter trimpots RF 1 thru 3 to bring the d.c. level within 5 mv of zero. The preamp trimpots are very sensitive and there is a delay in the signal response after an adjustment due to the filter. Small changes are recommended. The filter trimpots react immediately and are very fine adjustments.
2. Drum Recorder Method: It is necessary to have the Data Monitor and a drum recorder for the procedure. Preamp inputs should be shorted and system warmed up for 10 minutes. Pick one channel on the Data Monitor to observe. Have the drum recorder amplifier on very low gain. Increase the gain on the recorder amp and observe any movement of the trace, which will indicate the electronics is not balanced. Adjust the corresponding preamp trimpot to correct for the trace offset. Keep increasing the recorder gain until the LSB of the A to D is clearly visible, while correcting for any offset with the preamp trimpot. Finally, adjust the filter trimpot until an increase in gain of the recorder amp does not cause any offset. This channel is now balanced and the procedure can be repeated for the other two channels. Once you are familiar with this method, you will find it quick and easy to use.

### C. Field Adjustments

Any field adjustments are difficult to perform and should be avoided. Always balance the electronics in a lab before taking it to the field. It is assumed that the seismometers will be connected to the inputs of the preamps. Check the balance for large errors, because seismic signals will be present and the traces will be moving around quite a bit.

### III. THEORY OF OPERATION

#### A. Overall System

The system input consists of three preamplifiers. Each preamp has a differential input to improve common mode rejection. The input impedance is matched to give the desired damping to the respective seismometer for each amp. The gain of each preamp is 200. Following the preamp stage is a low pass, Bessel type filter. It has 2 corners: the first at 0.05 Hz with 6db/octave attenuation and the second at 1 Hz with an additional 24 db/octave. Therefore, the total rolloff beyond 1 Hz is 30 db/octave. The output of each filter is sampled for 30 msec, 11 times/second, in a sequential manner. This time multiplexes the three signals into one. The multiplexed signal is next processed by three gain ranges and then sampled and held for each channel component. This is done so that the logic can sort through each gain range, starting with the highest gain, until it finds one less than the  $\pm 10v$  range of the A to D converter. When satisfied, the A to D converts the analog signal to 12 bits of digital information. If on the low gain range, the signal is not within  $\pm 10v$ , it is taken by the A to D anyway. A Larse module, that converts digital information into an FSK output, follows the A to D. The Larse module has a 16 bit capability; 12 are for the signal, the control logic provides 4 more, 2 for the channel address and 2 for the gain range. The control logic receives a sync signal from the Larse when it has finished transmitting a word. (The Larse has an internal crystal for timing.) Utilizing this sync pulse, the logic controls all channel switches, operates the sample and hold modules, decides which gain range to use, changes range switches, strobes the A to D converter, stops while the Larse accepts the digital word with address, and waits for the next Larse sync pulse.

The following pages contain detailed descriptions of each major subsystem in the block diagram (Figure 3-1). They are organized by the p.c. board on which the circuits appear.

#### B. Preamp Board (3 each)

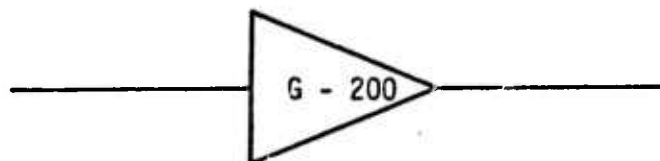

Each preamp is a single high performance 725 compensated op-amp, operated in a differential input mode to improve common mode rejection. With a gain of only 200, this stage has better than 0.01% linearity. Both input power lines are filtered to provide better power supply noise rejection. The op-amp I.C. itself is encased in a 1 1/4 inch square piece of synthetic foam rubber to provide temperature stability and isolation. The input impedance of this stage ( $z_{in} = 2R_1$ ) can be

# LONG-PERIOD FIELD STATION

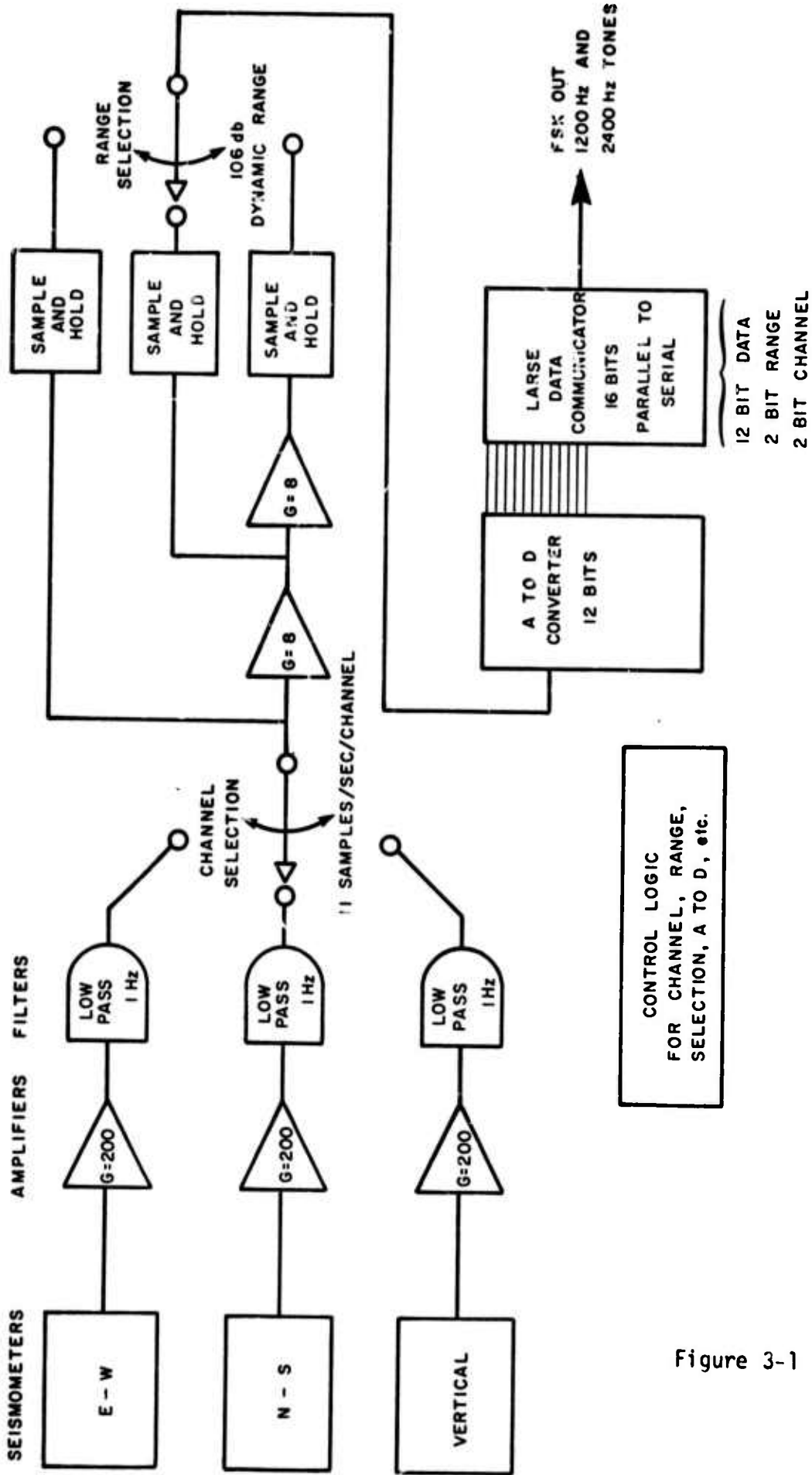
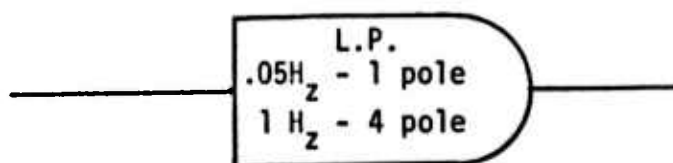

Figure 3-1

adjusted by changing both input resistors ( $R_1$ ). Any change in  $R_1$  must be followed with an appropriate change in both feedback resistors ( $R_2$ ) to provide the gain of 200. Each amp has an offset adjustment (RA 1 thru 3) for balancing the output around zero. It acts like a coarse trimmer.

C. Filter Board (3 each)



The total filter stage is composed of two filters in series. The first is a one pole,  $0.05\text{Hz}$ , low pass Bessel type, constructed with a single unity gain 725 op-amp. This first filter was included to enable one to shape the total system response. There is room provided on the p.c. board to extend this first filter up to 2 poles, or it can be completely removed and replaced by a jumper leaving only the  $1\text{Hz}$  filter. The cutoff frequency of first filter can be altered by changing the values of  $R_1$  and  $C_1$ .

The second filter is a commercially built four pole,  $1\text{Hz}$ , low pass Bessel type, of modular construction. An offset adjustment (RF 1 thru 3) of the output of this module, gives a fine tuning of the output zero.

Total system response

(Figure 3-2)

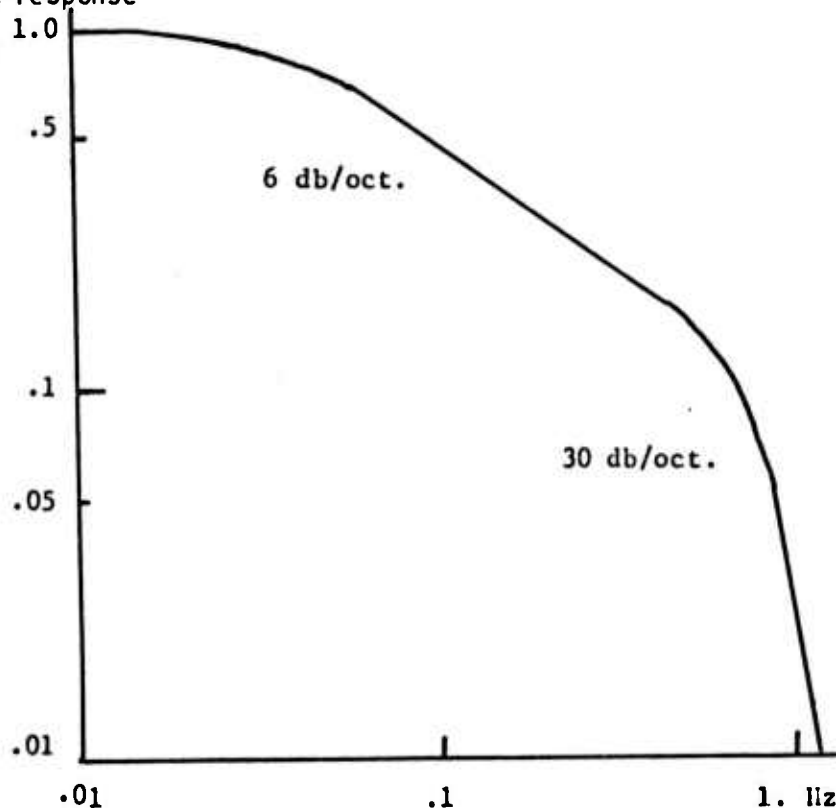

D. Sample and Hold Board. (3 each)

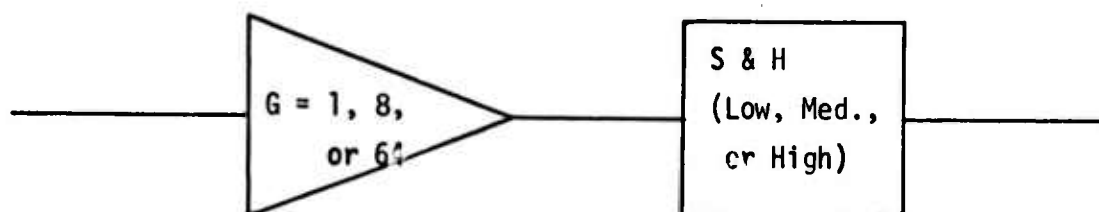

Each board has a gain range amplifier and a commercial sample and hold module. The amp is a single 741 op-amp operated in a non-inverting mode. An offset adjustment is provided on this amp to reduce any d.c. component between the outputs of the three sample and hold boards. This could cause an offset in the analog waveform when a different gain range is switched to the A to D converter. The output of the 64 gain amp has a 10 kHz filter to reduce high frequency switching noise.

The sample and hold is a commercial module that samples (tracks) with a +5v control level and holds on a zero level.

The negative side of the power to each of these stages on this board is filtered to improve power supply isolation.

E. Control Logic Board. (1 each - see Figure 3-3)

Block Diagram Description:

This is a wire-wrap board with dual-in-line integrated circuits (I.C.). They are mostly TTL logic, with a few Cos/mos buffers for interfacing to the Cos/mos logic A to D, and 6 analog electronic switches. The Larse sync pulse initiates the logic sequence. It drives a "divide by three" to sequentially trigger 3 analog electronic switches to sample the three channels and resets the range switches to the highest gain. At the same time, the sample and hold (S & H) control is changed to hold from sample, and a 1/2 msec delay is started which gives the electronic switches time to react. After the delay, the A to D converter is started. The 5 most significant bits (MSB) of the A to D are monitored by the logic. If the magnitude of the analog signal is less than about 9.5 volts, the logic waits and the Larse takes the data. If the signal is too large, then the logic checks to see if it is on the low range yet. If it is, the logic stops and waits for the Larse. If not, it starts the 1/2 msec delay again and tells the range control to go to the next lower gain. This process continues until the magnitude of the signal is less than 9.5v or the low range has been reached. In either case, the logic process stops and waits for the Larse sync pulse to start it again. In the meantime, the Larse takes the data.

All circuit elements on the logic board are coded on the diagram

LOGIC FLOW DIAGRAM

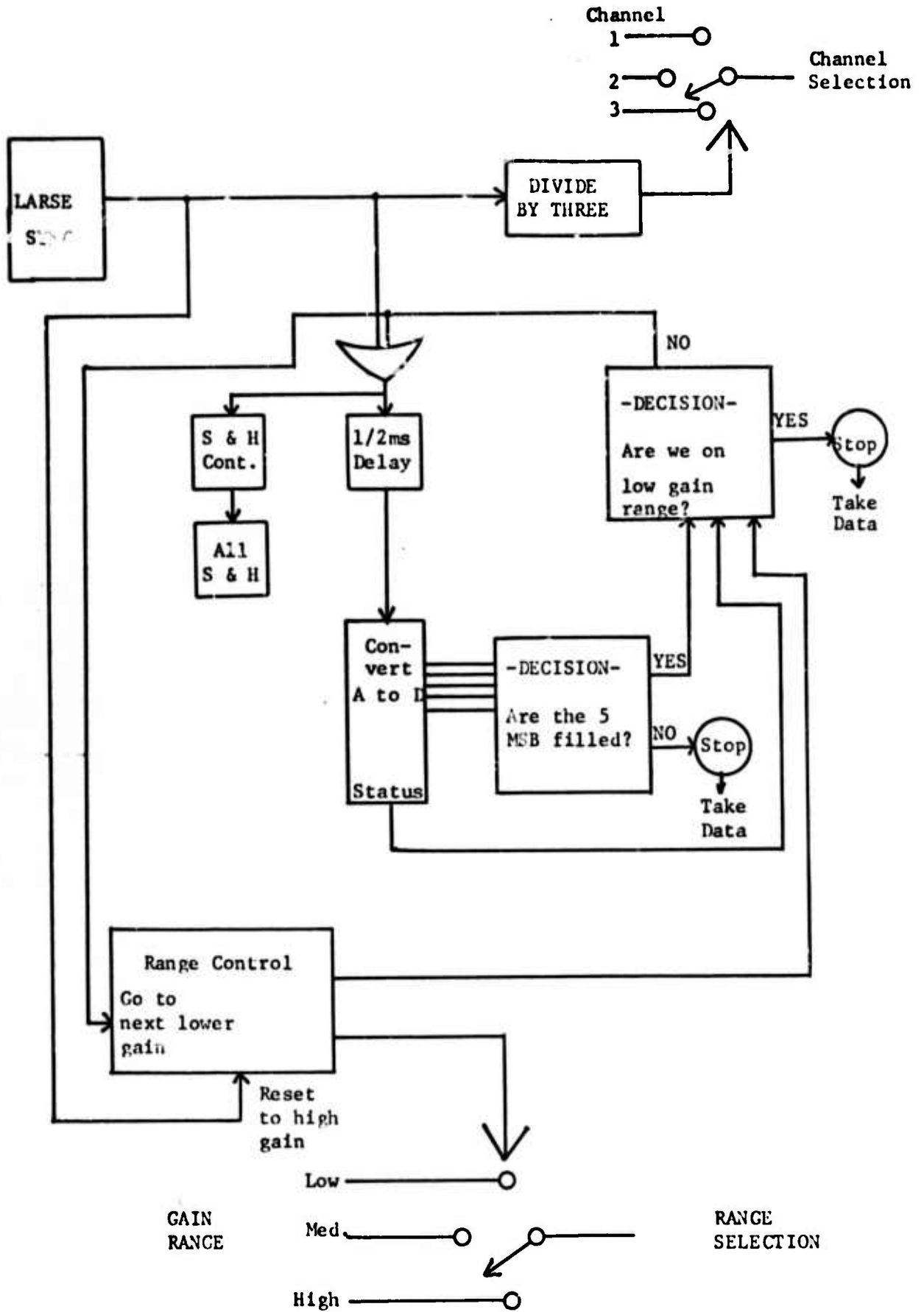

Figure 3-3

as well as on the circuit board. The first letter of the code tells what kind of a logic I.C. the particular device is (i.e., MC 2 - M stands for Monostable). The second letter indicated in which dual-in-line of that same type the function is located (i.e., MC 2 - C stands for the third dual-in-line of the Monostables). The number stands for the number of the function in that particular dual-in-line (i.e., MC 2 - 2 means the second Monostable in the third dual-in-line I.C.).

First letter code:	Type of I.C.	I.C. #
A -	And	SN 7408
B -	Buffer	SN 7417 or CD 4010AE
C -	Capacitors	
J -	J - K	SN 7476
M -	Monostable	SN 74121 or 74123
N -	Nor	SN 7402
P -	Pull-up Resistors	
S -	Switch, Electronic	AH 0141CD
T -	Timing Components	

Second letter code: (upper or lower case)

A -	1st	dual-in-line I.C.
B -	2nd	dual-in-line I.C.
C -	3rd	dual-in-line I.C.
D -	4th	dual-in-line I.C.
E -	5th	dual-in-line I.C.

Third Character (Number)

1 -	1st gate in that I.C.
2 -	2nd gate in that I.C.
3 -	3rd gate in that I.C.
4 -	4th gate in that I.C.
5 -	5th gate in that I.C.
6 -	6th gate in that I.C.

## Total number of I.C.'s used on each logic board

TTL - I.C.'s	Type	Quantity
SN 7402	Quad Nor	2
SN 7408	Quad And	3
SN 7417	Hex Buffer	2
SN 7476	Dual J - K	2
SN 74121	Single Monostable	1
SN 74123	Dual Monostable	2

Cos/mos I.C.'s	Type	Quantity
CD4010AE	Hex Buffers	3

Elect. Switches	Type	Quantity
AH0141CD	Dual SPST - 10 $\Omega$	3

The 1.6 msec Larse sync pulse is used to initiate the logic process. Since all Larse outputs are open collector transistors, there is a pull-up resistor on the logic board for the sync output. This sync pulse triggers a divide by three logic sequence, (, A 1 & 2). These Jk gates with an AND gate (AA4) drive the channel switches thru buffers (Be 1, 2, & 3). These buffers have a capacitor to ground and pull-up resistor on their output to provide a fast turn-off time and slow turn-on time to the electronic switches. This reduces channel cross-talk. Each electronic switch is a SPST type and has an on resistance of 10 $\Omega$ .

The Larse sync pulse is also used to start a Monostable (MC 2). It is triggered by the front edge of the Larse pulse. This monostable provides a narrow timing pulse for further triggering. It resets the range switch control (divide by three, JB 1 & 2) to the high gain range switch. The range control drive circuitry is so similar to the channel drive that it will not be discussed.

The output of MC 2 also passes thru Nor gate A2 to start two other monostables (MA 1 and MC 1). MC 1 provides the drive for all the S & H modules. It changes the modules to hold at the start of the Larse pulse and maintains that state for 14 msec, more than enough time for the logic to complete all its testing, before putting the S & H's back to the sample mode. Monostable MA 1 provides a 1/2 msec delay before triggering MB 1 to strobe the A to D thru buffer Bd 1. The delay is needed to allow the channel and range switches time to change as well as to guarantee some time for the analog signal to settle down after switching. The A to D requires a specific timing

LOGIC TIMING DIAGRAM

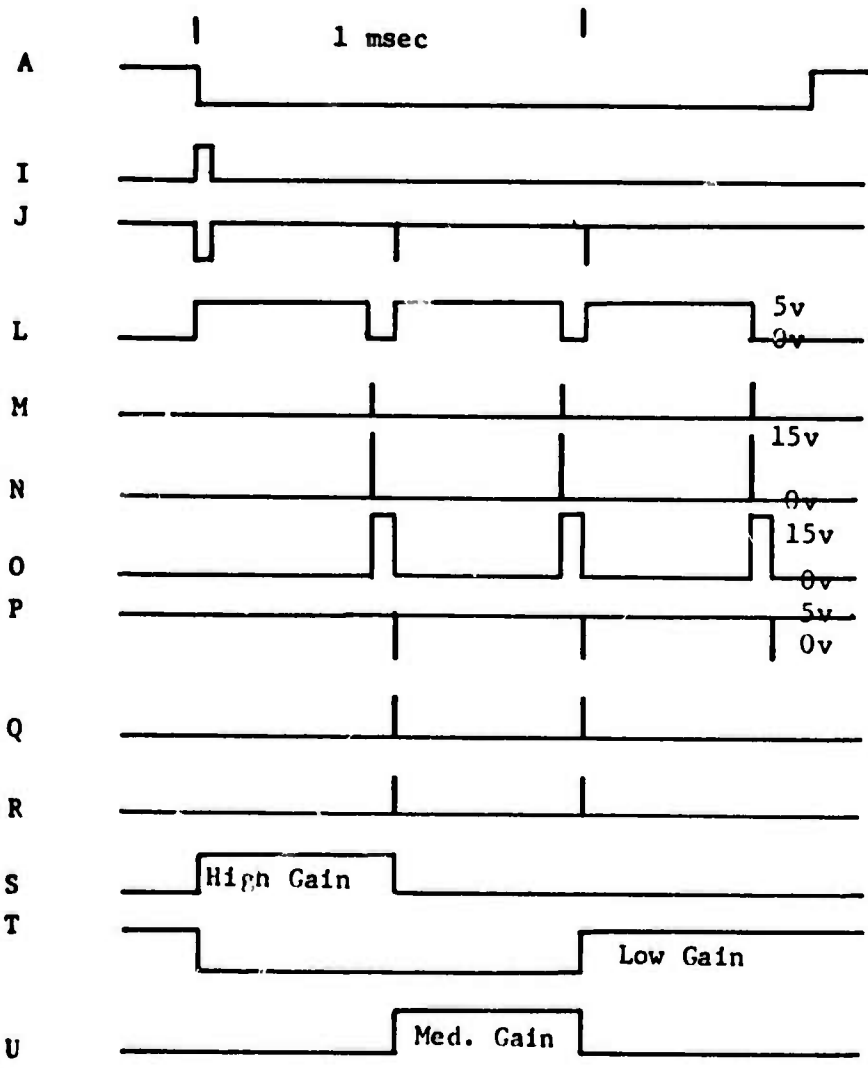
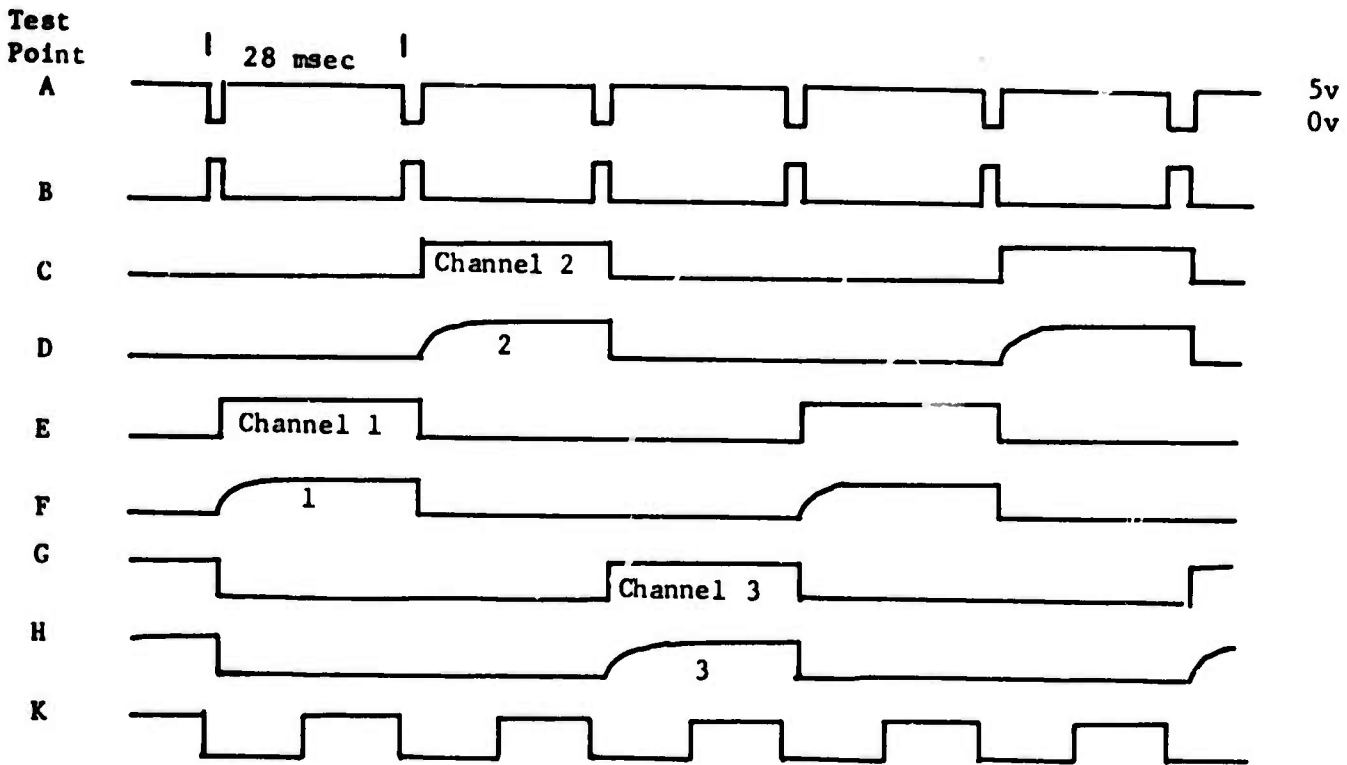

Wave Forms on Logic Board

The upper set of wave forms show the channel selecting process. The basic time is 28 msec. The lower set of wave forms shows the gain ranging process. The basic time is one msec. The input signal is large enough in this case to trigger all three gain ranges. The Large sync pulse (A) was used to trigger the scope.

Figure 3-4

pulse to trigger it. Monostable MB 1 provides a 2  $\mu$ sec pulse to satisfy the A to D. Since the A to D is Cos/mos logic, all inputs and outputs to it are buffered. The A to D status goes high during conversion (about 85 msec) and returns to zero afterwards. This status is buffered (Bc 1) and triggers monostable MB 2. All 12 bits of data from the A to D are buffered (Ba 1 thru 6 and Bb 1 thru 6). The A to D digital output is offset binary code. If the analog signal nears  $\pm 10$  volts, we want to change to the next lower gain range. The first bit (MSB) is the sign (1 for +, and 0 for -). When the analog signal reaches + 9.375v all the first 5 bits are ones and at - 9.6875v all the first 5 bits are zero. So if all the first 5 bits are ones or zeros, the output of NA 3 becomes zero, allowing the monostable output pulse from MB 2 to pass thru NA 4. If the analog signal is below the prescribed limits, NA 3's output is high and the triggering pulse from MB 2 is blocked at NA 4. This provides the decision to go to the next gain range when the triggering pulse is passed. Next, And gate AA 1 checks through Nor gate NB 3 to see if the range control is on the low gain switch yet. If this condition is true, then the other two gain ranges have already been tried and the data must be taken on the low range no matter what its amplitude is. By this means AA 1 decides whether to let the trigger pulse from MB 2 pass on to strobe the range control to the next lower gain range and to restart the cycle thru Nor gate NA 2. This cycle repeats until the signal level is satisfied or the low gain range is reached. All pull-up resistors, capacitors and timing elements for the logic are held on dual-in-line adaptors. See Figure for their placement.

The logic provides 4 bits of digital address to the Larse for channel and gain range information. The code is as follows:

Channel	Larse bit		
	14	15	
1	0	1	CHANNEL CODE
2	1	0	
3	0	0	

Total System Gain	Larse bit		
	12	13	
High 12,800	0	0	GAIN RANGE CODE
Med. 1,600	0	1	
Low 200	1	0	

F. Analog to Digital Converter Board. (1 each - commercial)

This commercial A to D board converts an analog signal into 12 bits of digital information. It has a very low power requirement,

since it only turns itself on when strobed. It also utilized Cos/mos logic for further power reduction. Its output code is offset Binary, an example of which is shown below:

OFFSET BINARY DIGITAL CODE

	MSB											LSB
	1	2	3	4	5	6	7	8	9	10	11	12
+ Full scale -1 LSB	1	1	1	1	1	1	1	1	1	1	1	1
+ 3/4 Full scale	1	1	1	0	0	0	0	0	0	0	0	0
+ 1/2 Full scale	1	1	0	0	0	0	0	0	0	0	0	0
Zero	1	0	0	0	0	0	0	0	0	0	0	0
- 1/2 Full scale	0	1	0	0	0	0	0	0	0	0	0	0
- 3/4 Full scale	0	0	1	0	0	0	0	0	0	0	0	0
- Full scale +1 LSB	0	0	0	0	0	0	0	0	0	0	0	1
- Full scale	0	0	0	0	0	0	0	0	0	0	0	0

G. Larse Communicator Board. (1 each, commercial)

This module converts 16 bits of digital information into an FSK output with 1200 and 2400HZ tones. It has an internal crystal, so its sync timing pulse is used for an accurate timing trigger to the total system logic. The sync signal is high as the base unit accepts the bits in a sequential manner, then it goes low for 1.6 msec to indicate the end of word. The reader is forewarned not to expect to gain much information by reading the Larse Manual; it is poorly written.

CORRESPONDENCE BETWEEN DIGITAL BITS

LARSE BIT #

0	12	LSB
1	11	
2	10	
3	9	
4	8	
5	7	
6	6	
7	5	
8	4	
9	3	
10	2	
11	1	MSB

A to D Bits

12 ) Range address  
13 )  
14 ) Channel Address  
15 )

See Logic Board  
Description for Code.

#### H. Input - Output Board. (1 each)

This board consists of two separate sections. The input side has a 1 Amp Fuse (1 1/4" x 1/4") for the input 24 volt line. There is a spark gap, zener diode, and capacitor for lightning protection on the input power line. The zener and 1 Amp fuse also provide over-voltage and reverse voltage protection for the system.

The output side gives protection to the Large Communicator. It consists of a 600 OHM, 1 to 1 isolation transformer, with lightning protection on its output; two spark gaps and two sets of back to back zeners from each line to ground.

#### I. Power Supply Boards.

##### Switching Regulator Boards (+15v, +5v) (1 each)

These two boards are identical except for a few components. R<sub>1</sub> & R<sub>2</sub> adjust the output voltage of each unit. The 5 volt board has a larger output filtering capacitor arrangement. Each board has a zener across the output for overvoltage protection. On the +15 volt supply, there is a series resistor and capacitor to ground on the input line to delay the +15 volts from coming on before the -15 volt supply.

The basic circuit of these two supplies is based on a switching regulator design by National Semi. Due to the power restriction on the field station, it was necessary to use switching regulator with their high efficiency (80%). However, this type of regulator has an undesirably high output ripple, which can be troublesome.

##### -15 Volt Inverter Board (1 each)

This is a commercial inverter mounted on a P.C. board, capable of 200 m-amps output. An overvoltage protection zener has been added to the output of the supply. There is also a diode in series with the output line. This is to help stop any +15 supply current getting into the inverter and biasing the output stages such that they will not work. The input line delay on the +15 volt supply is also to help this situation.

#### IV. TROUBLE SHOOTING

Always check power first.

##### +24v

Check fuse on I/D board and monitor 24v at that point.

##### +15v

Check for +15v on pin 7 of I.C. socket (741) on S & H board. The I. C. regulator LM 305 on regulator board is the weak link. It fails

and allows full supply voltage (24v) to pass. This is protected by zeners on each board.

#### +5v

Check for +5v on logic board top plane (I.C. side). Same comments as for +15v.

#### -15v

Check for -15v on pin 4 of I.C. socket (741) on S & H board. This inverter is very peculiar. It must come on before +15v regulator or it fails to function. This has been corrected by an R.C. delay ( $R_5$  and  $C_3$ ) on the +15v regulator. This allows -15v to come up first. Also adjusting the +15v regulator to be a little lower in magnitude than the -15v helps change  $R_1$ .

#### Larse Output

Observe output with floating inputs to scope. Should look like a serial train of 1200 and 2400 Hz tones, indicating the different data bits. The Larse module gives an output, regardless of input.

#### Signal Tracing

Monitor input to S & H boards at connector pin S 1-3, or on board S1. Pin 6 of the I.C. socket (741). Should observe a multiplexed signal. Driving each preamp will change the level of one of the multiplexed signals. The multiplexed signal with gain ranging can be observed on connector pin AD-18 or on the A to D board itself. There are two resistors on the top of the board mounted on standoff. Find the maximum signal on one of these posts. Here one should find a multiplexed signal with d.c. levels corresponding to the sampled signal. Driving a preamp will cause a d.c. level to change and gain ranging can be observed, that is a d.c. level will increase as the input increases. As the d.c. level approaches 10 volts (pin AD-18 only) output, it will jump to 1.25v and repeat this once more, the higher the input is. Any failure of the channel selection or gain ranging is due to the logic. Thorough familiarization with the logic is required to correct a logic problem.

#### Logic

For any logic problems, trace through the circuitry while operating with a scope, starting at the Larse sync (A). Use the timing diagram given in the Theory of Operation. If the waveform is correct on one side of an I.C. and not on the output of it, replace that I.C. Watch the CD4010AE buffers. They are sensitive to static charge while they are being handled.

V. Wiring Diagrams and Schematics

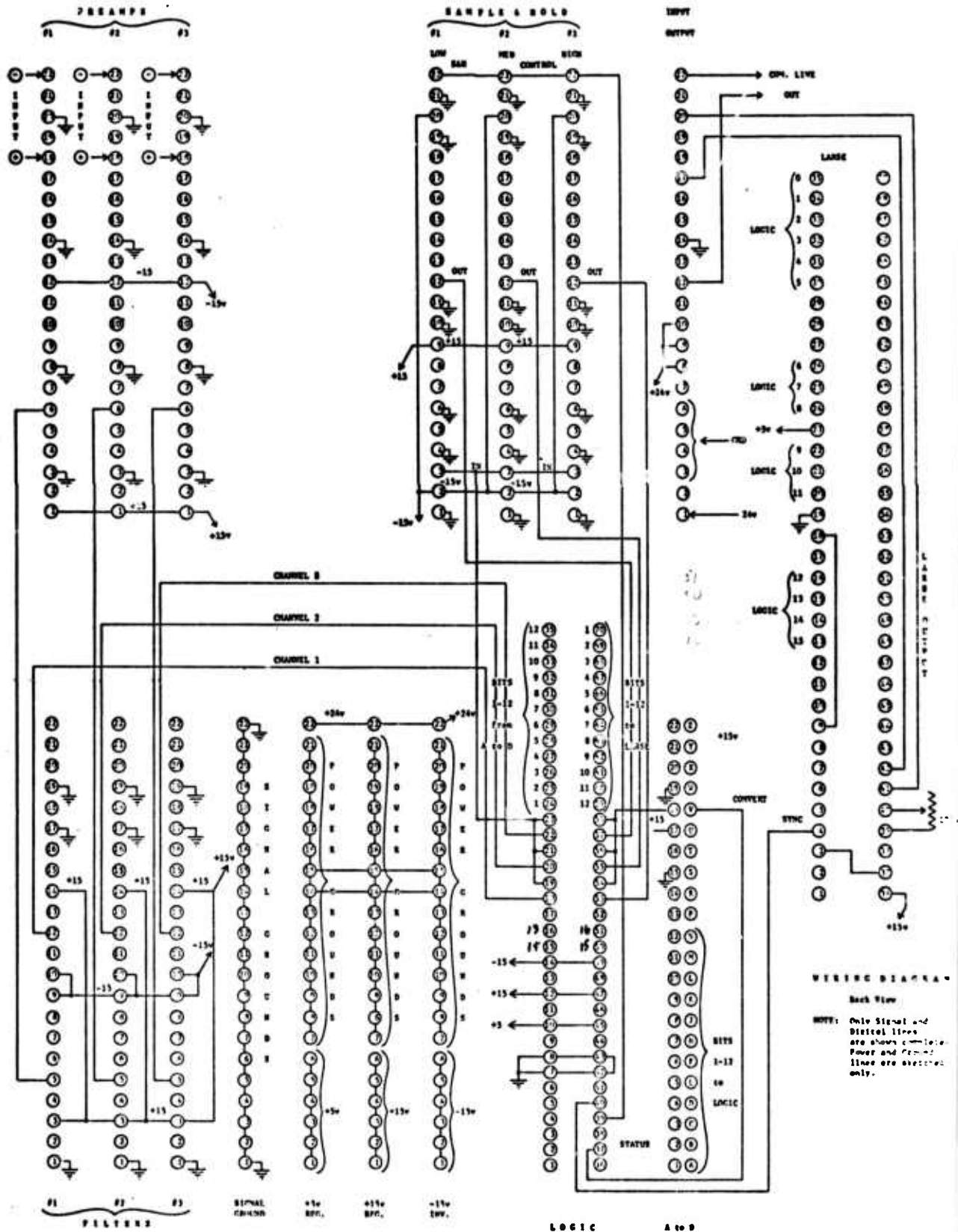

SYSTEM RACK  
& CARD LOCATION

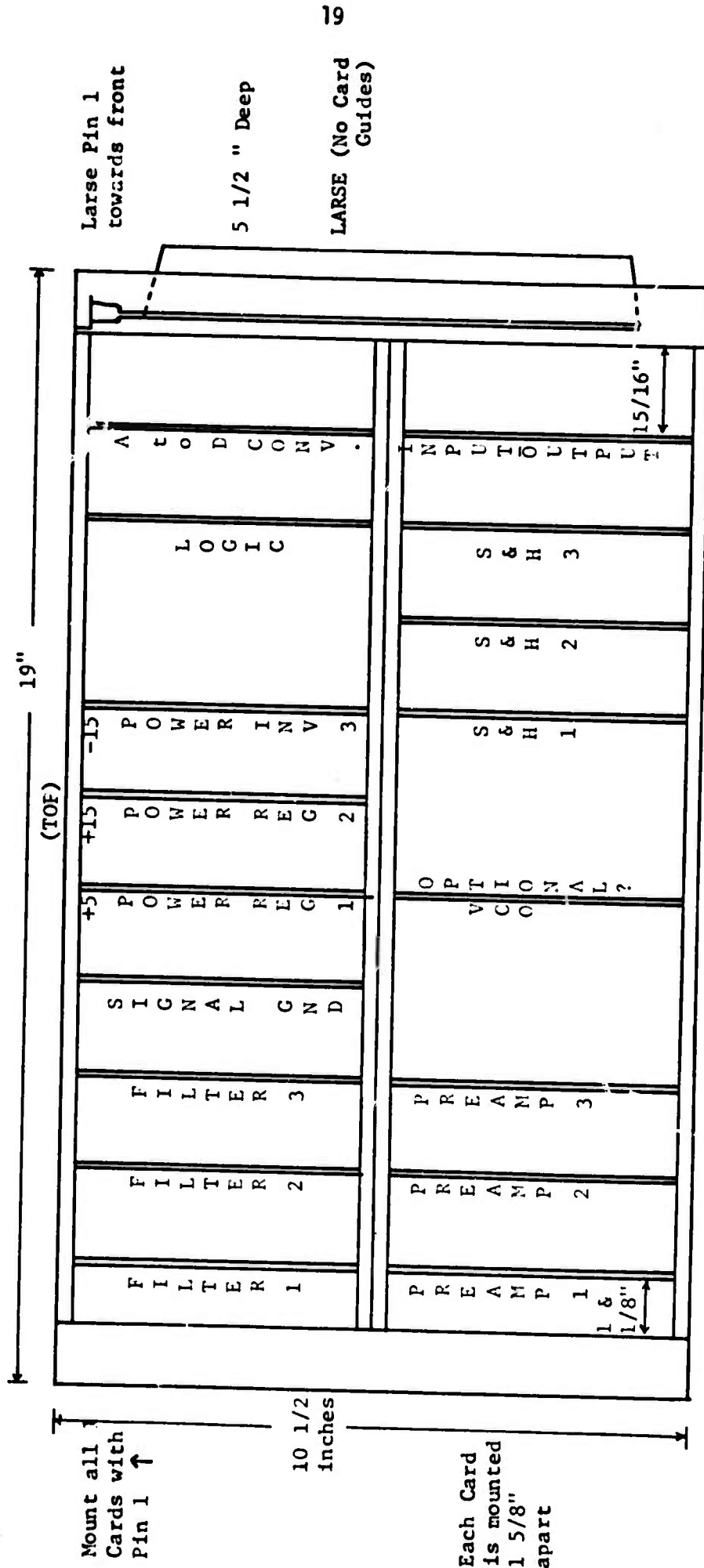

FRONT VIEW

Thermalloy twin-pak card rack #5005-121-T with card guides #5005-01N

Put Shielding around all power supplies and around each Preamp and filter, all sides.

TYPICAL PREAMPLIFIER (1 of 3)

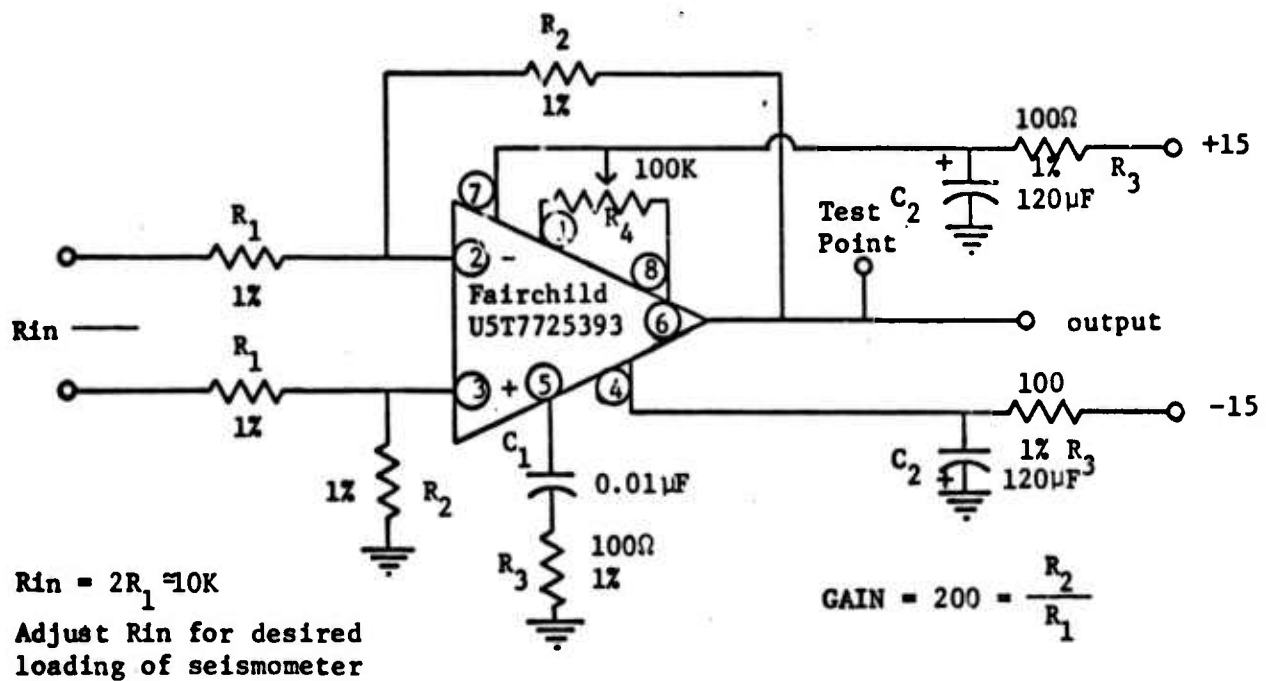

COMPONENT ARRANGEMENT

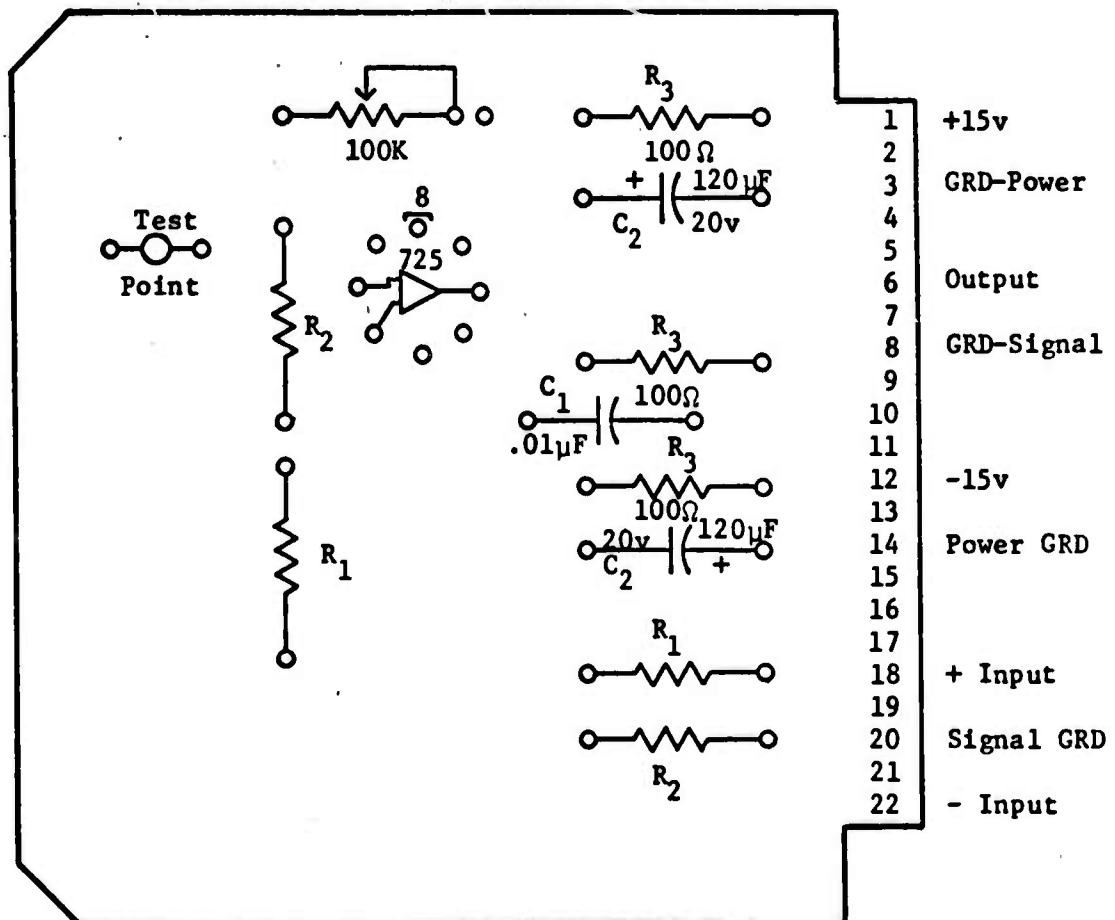

BOARD LETTERED "A"

TYPICAL FILTER (Bessel Function)  
(1 of 3)

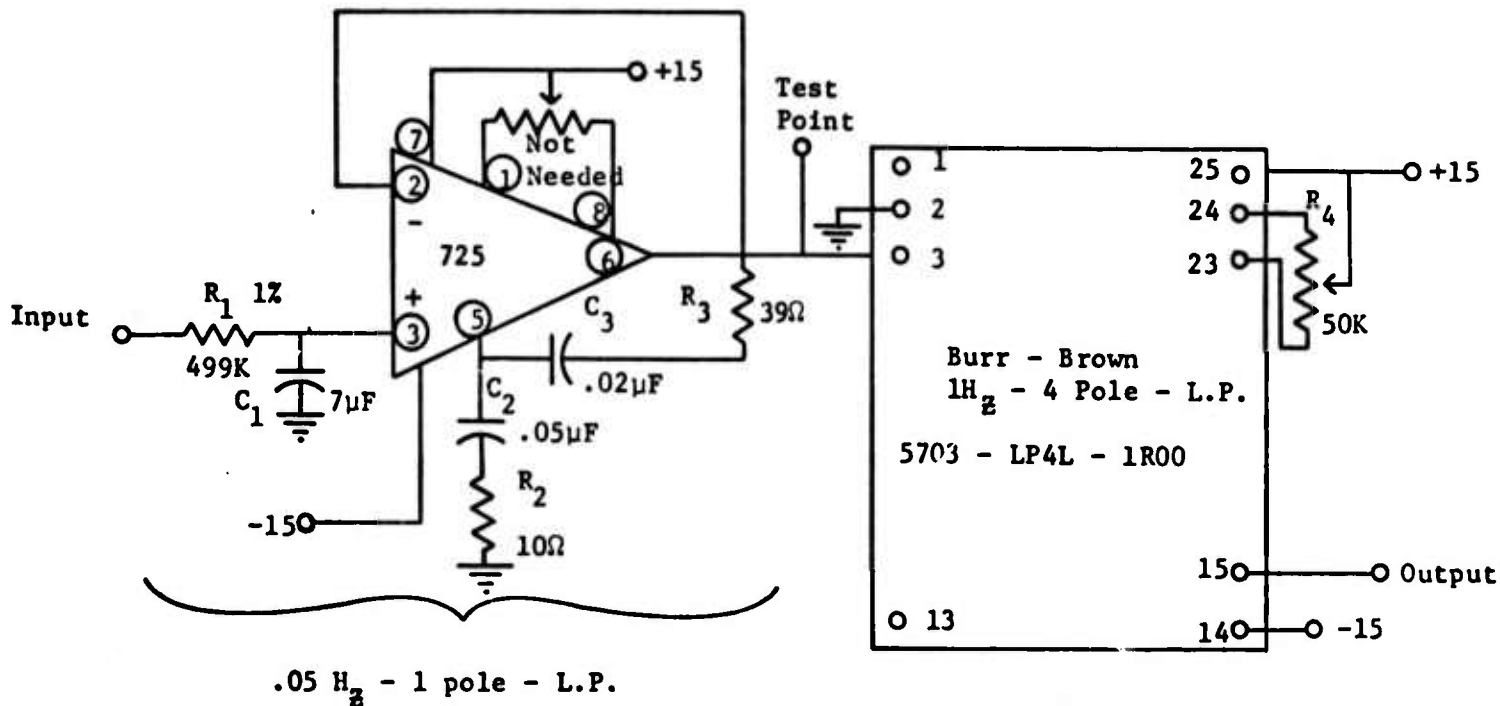

COMPONENT ARRANGEMENT

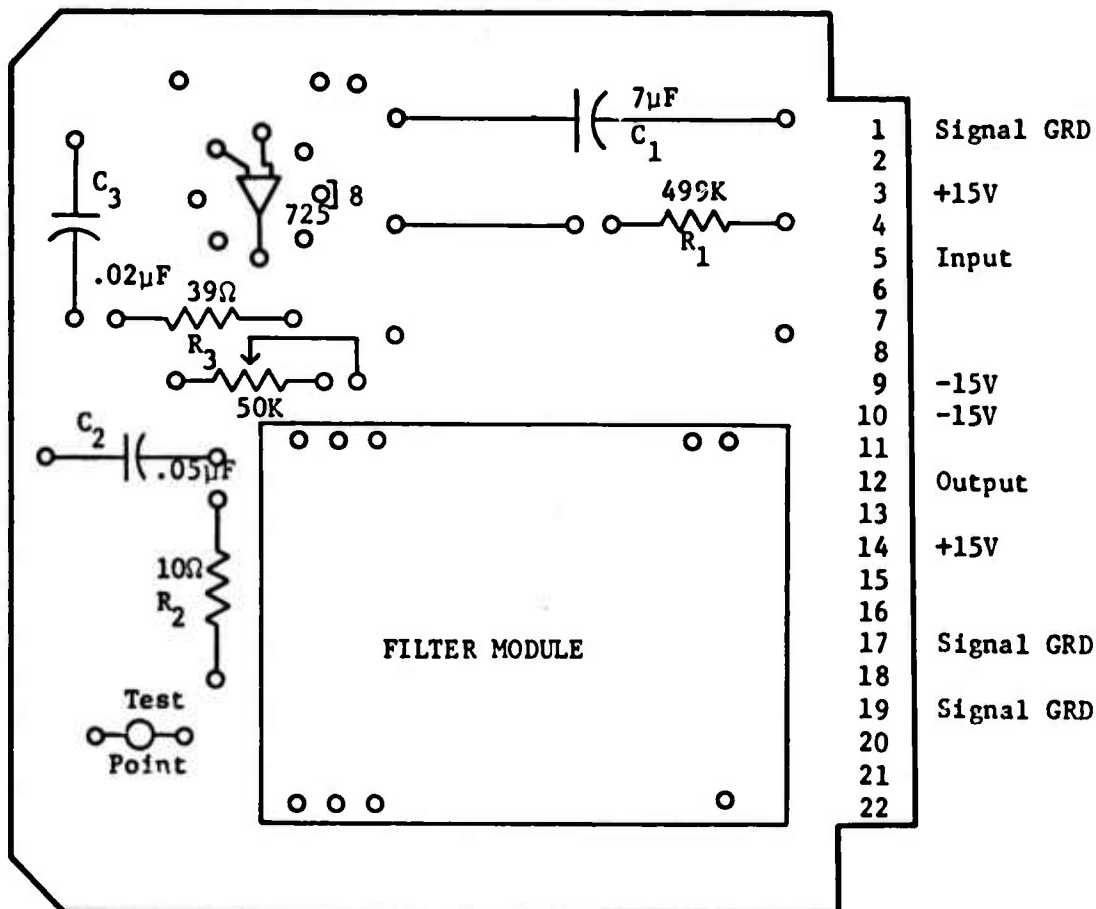

BOARD LETTERED "F"

TYPICAL SAMPLE AND HOLD WITH GAIN RANGING (1 of 3)

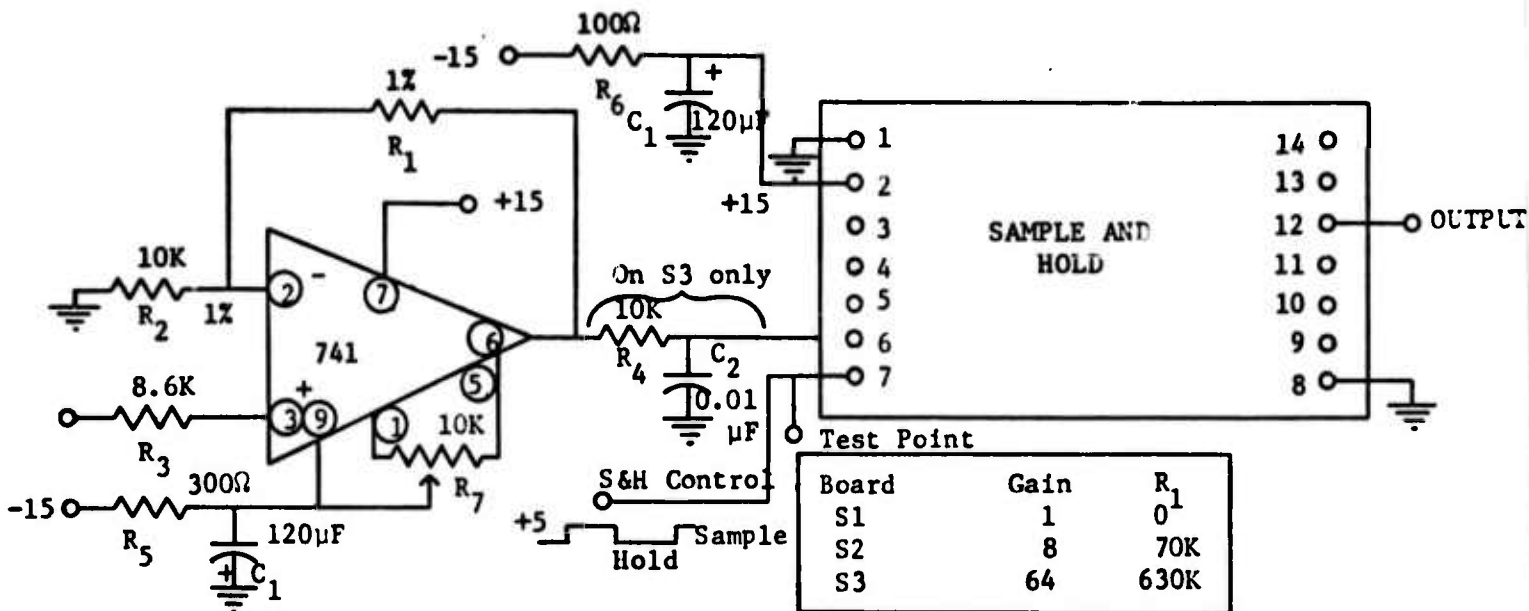

COMPONENT ARRANGEMENT

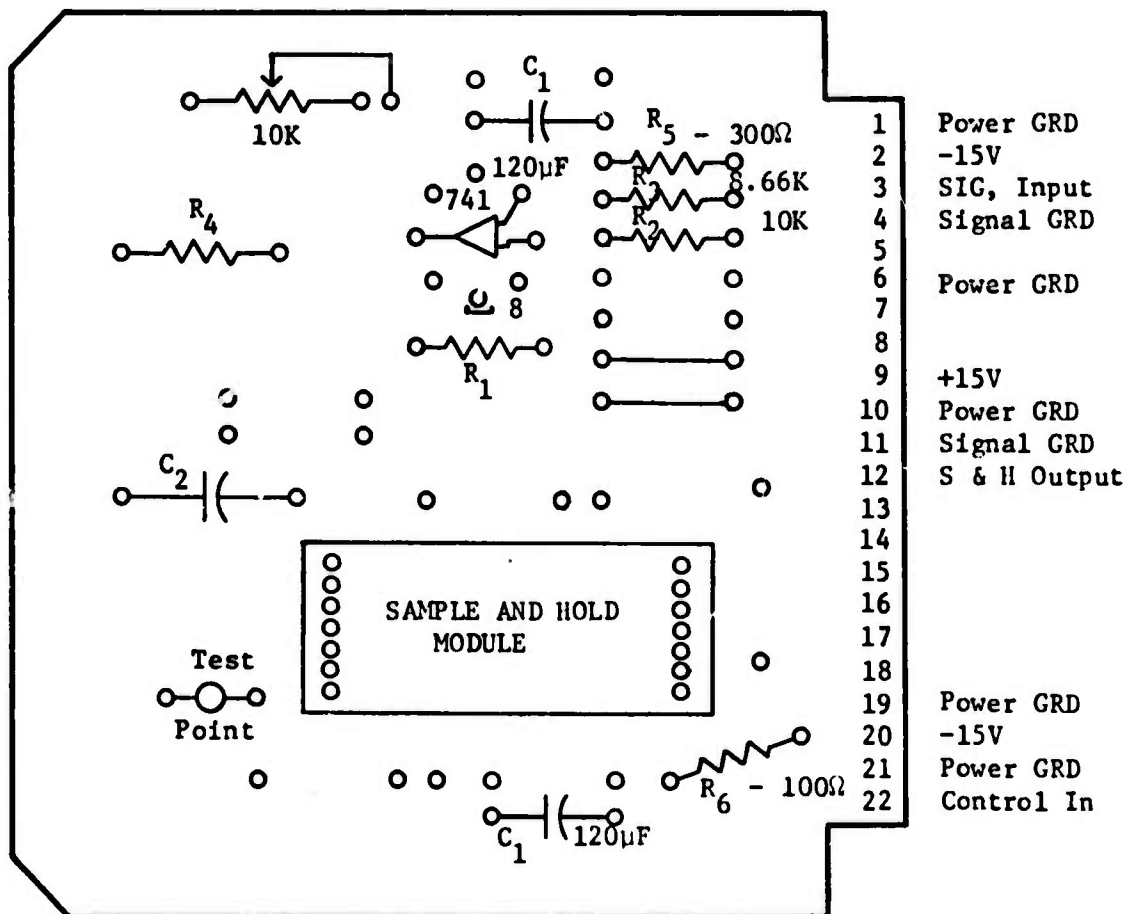

BOARD LETTERED "S"

## S I G N A L   G R O U N D   B O A R D

This board enables one to remove all signal ground common points easily and is separate from the power grounds

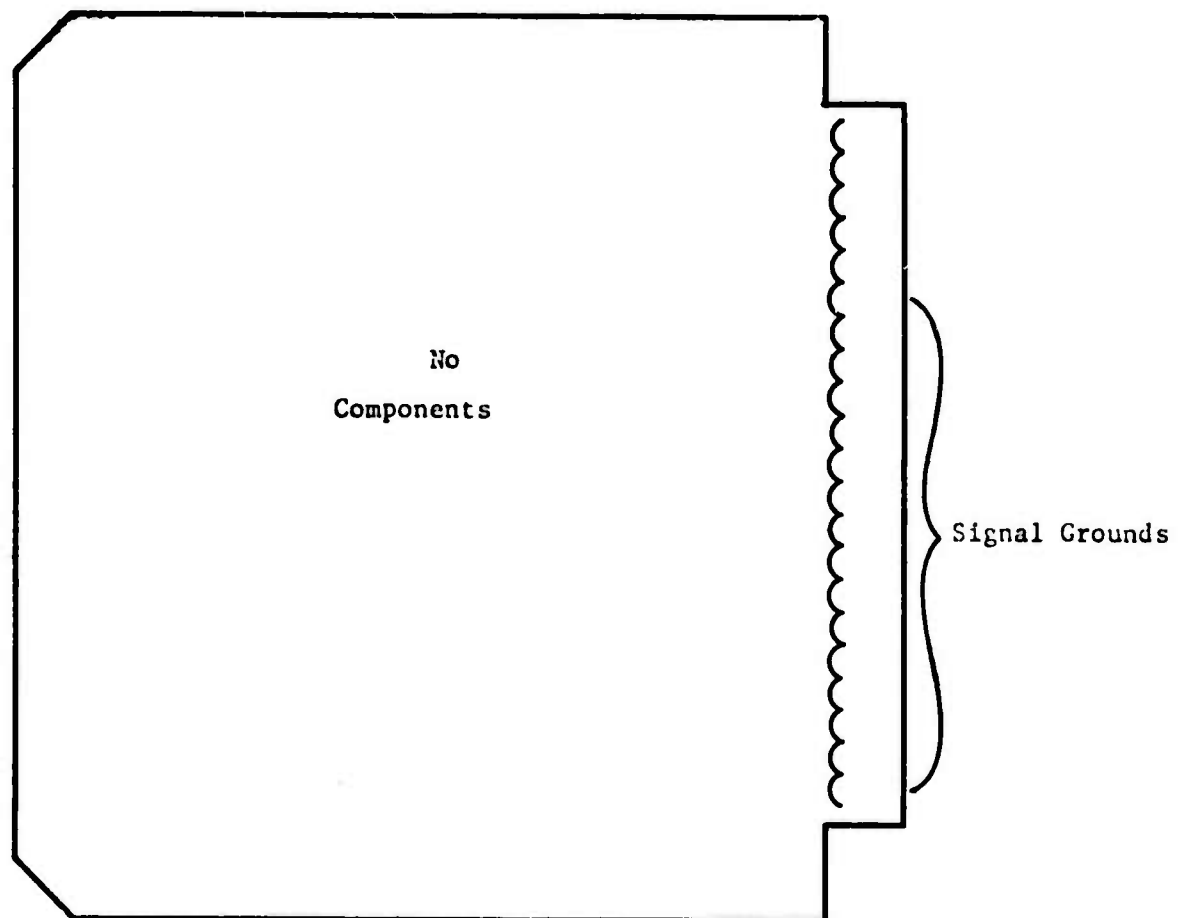

LOGIC DIAGRAM

CHANNEL MULTIPLEX RANGE SELECTION

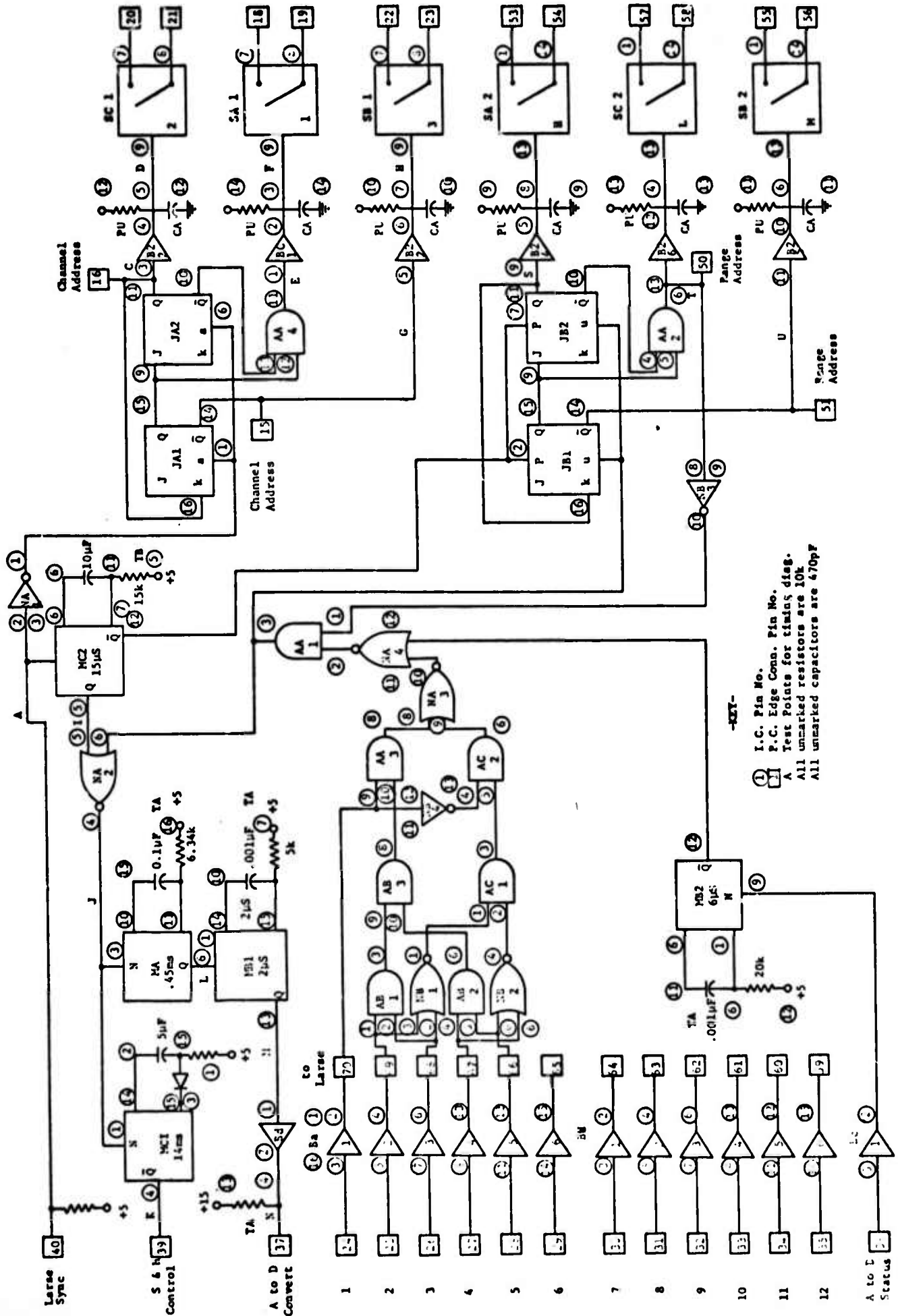

① I.C. Pin No.  
 ② P.C. Edge Conn. Pin No.  
 A Test Points for timing diag.  
 All unmarked resistors are 10k  
 All unmarked capacitors are 470pF



ADAPTER BOARDS FOR CONTROL LOGIC  
(COMPONENT ARRANGEMENT)

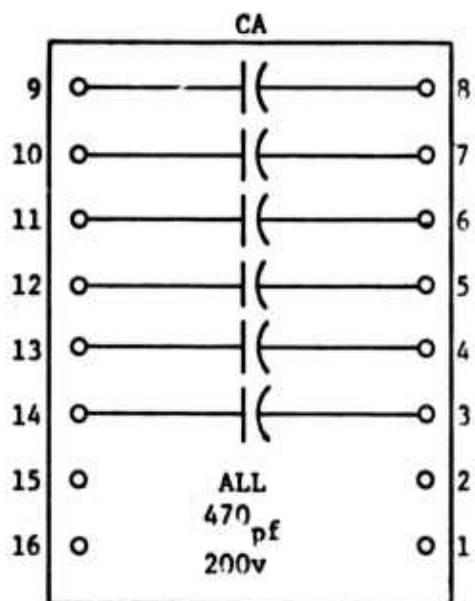
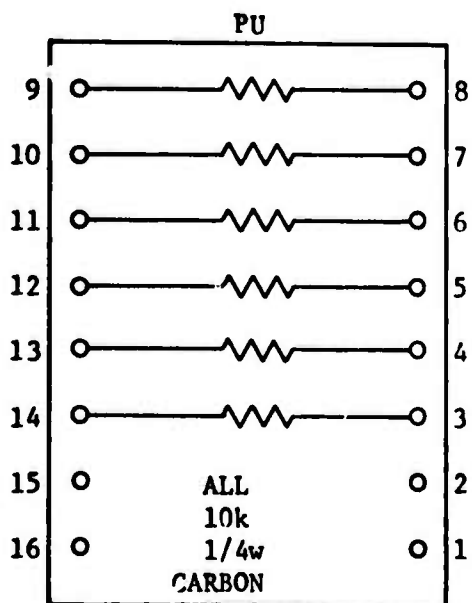
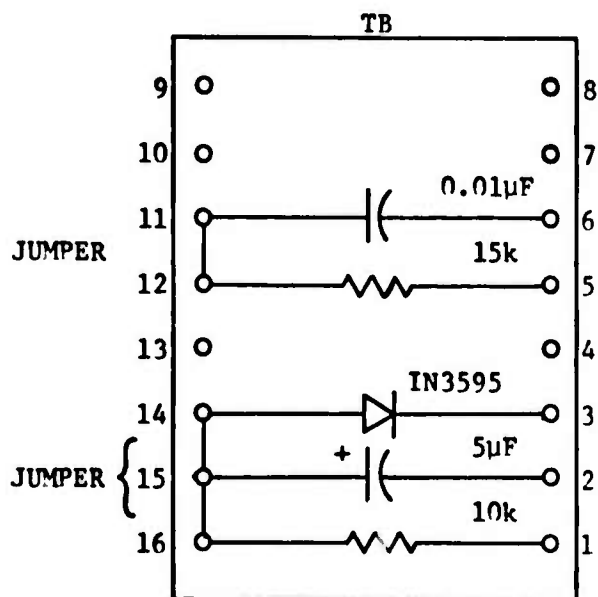
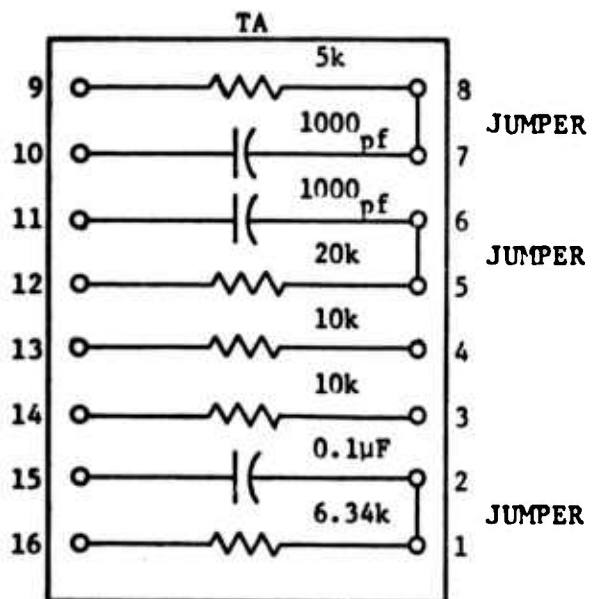

USE CAMBION SOCKET ADAPTERS #702-3728-01-03 OR EQUIVALENT

INPUT - OUTPUT BOARD (1 only)

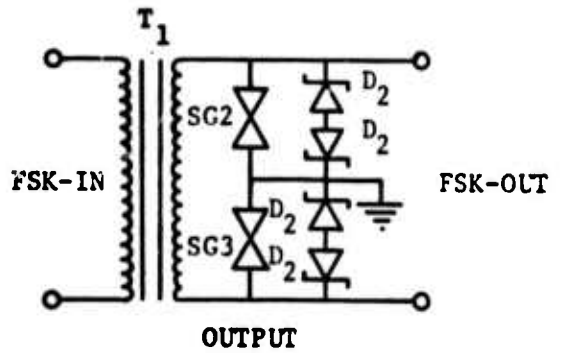
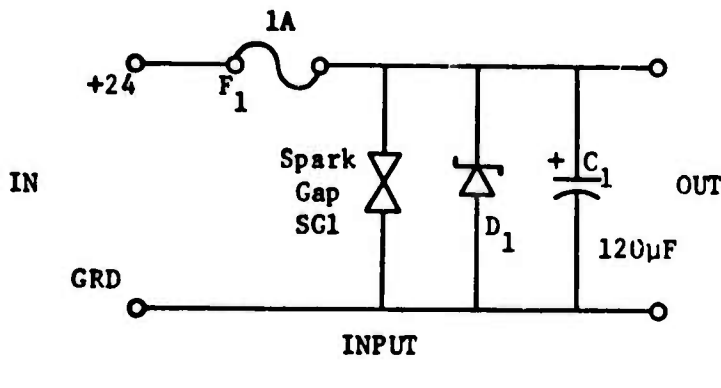

COMPONENT ARRANGEMENT

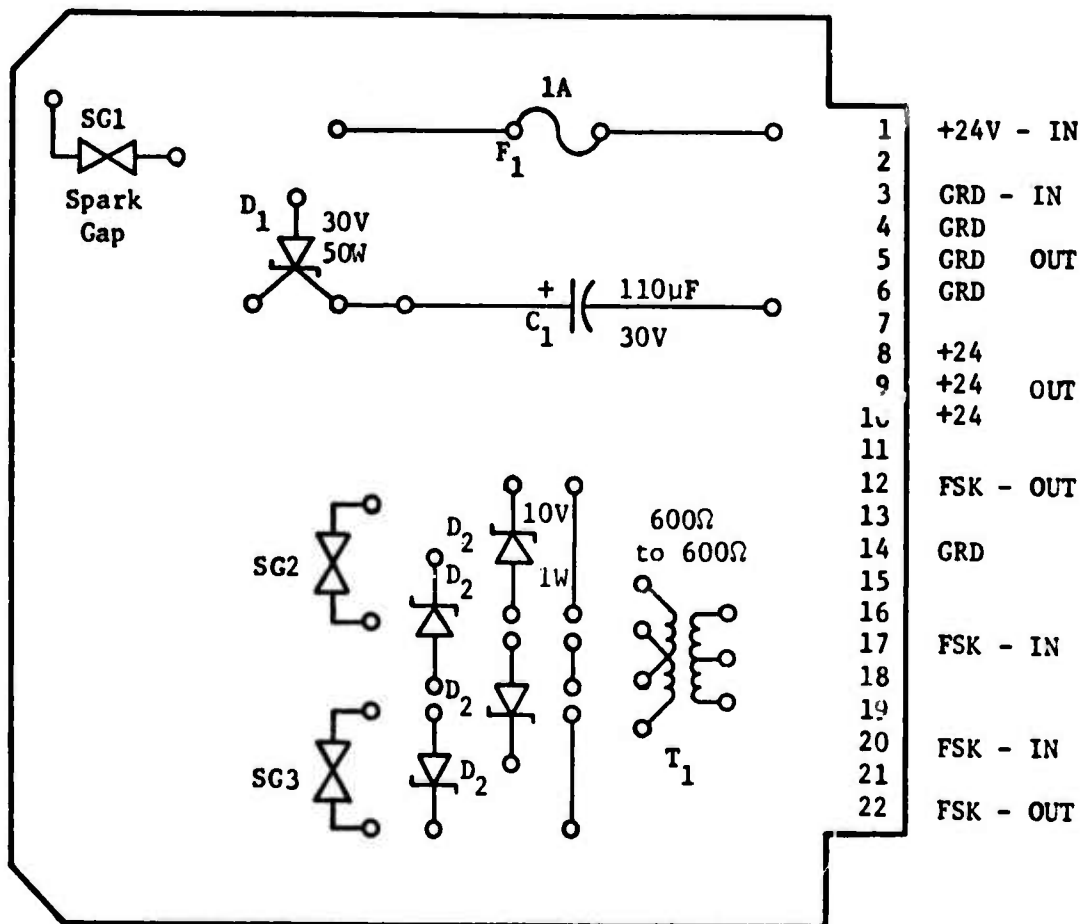

BOARD LETTERED "O"

SWITCHING REGULATOR (1 of 2)

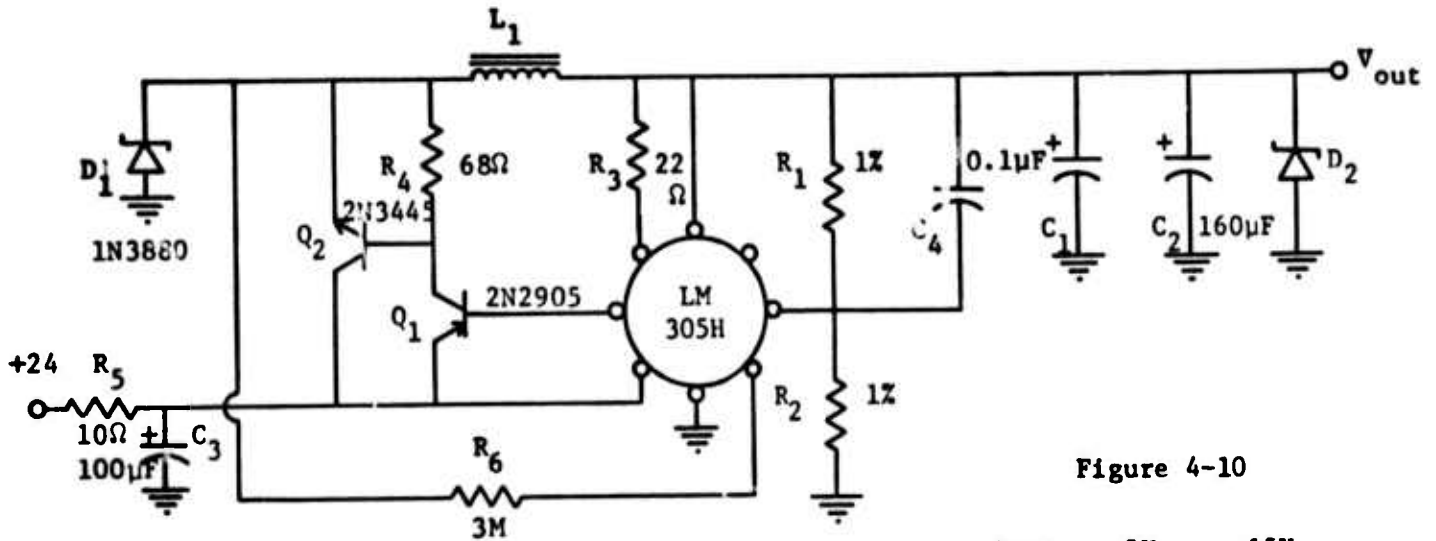
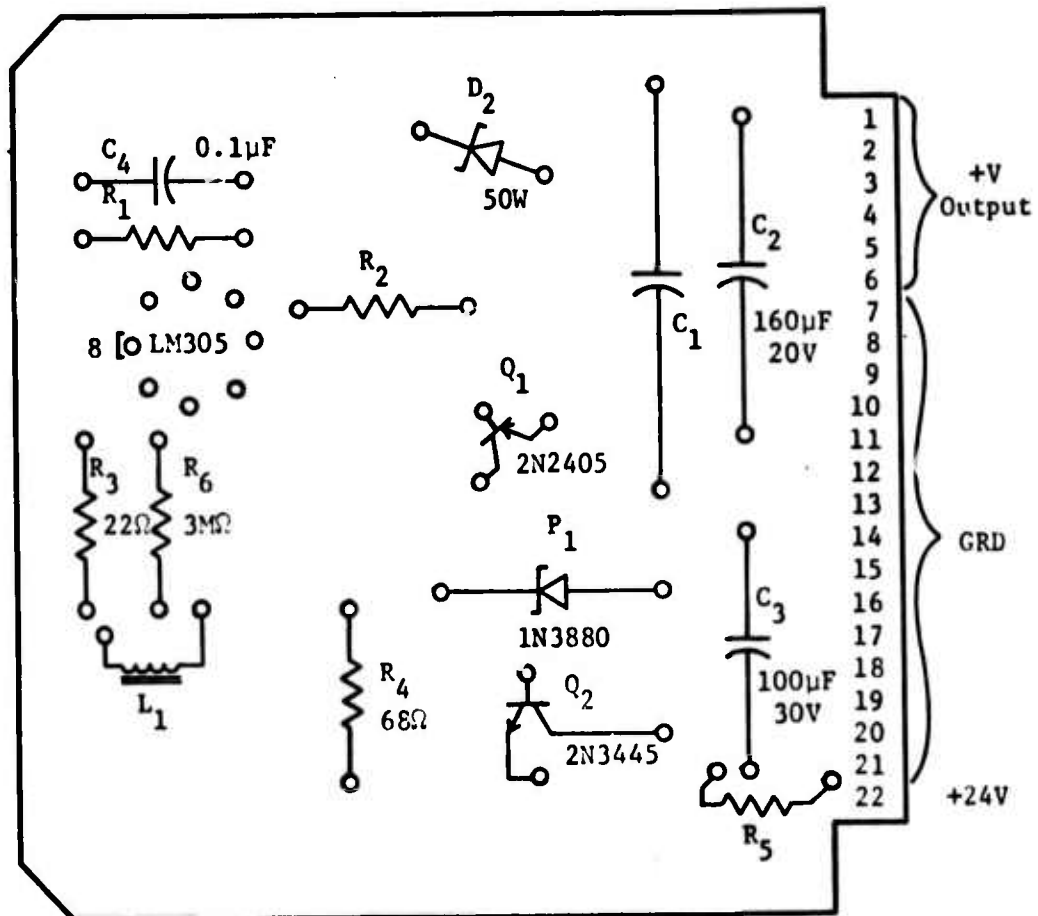

Figure 4-10

L<sub>1</sub> is 50 turns of #20 wire on Arnold Engineering Core A930157-2

V <sub>out</sub>	5V	15V
R <sub>1</sub>	5.9K	20.5K
R <sub>2</sub>	3.09K	2.67K
C <sub>1</sub>	160μF	100μF
D <sub>2</sub>	7.5V	18V

COMPONENT ARRANGEMENT



BOARD LETTERED "+P"

-15v I N V E R T E R (1 only)

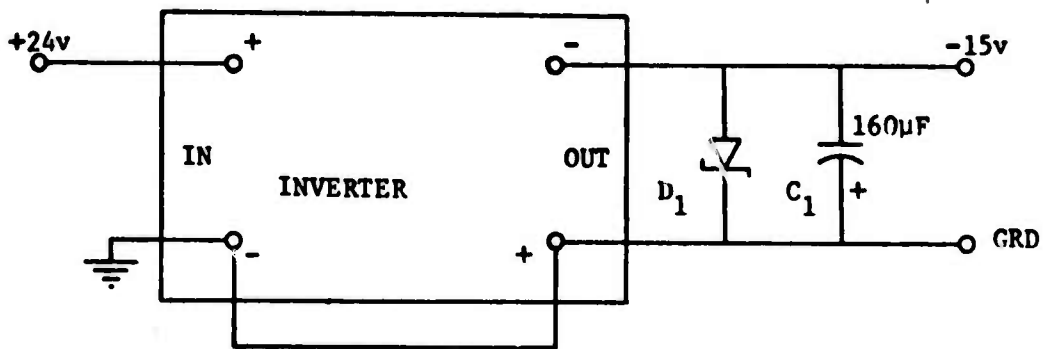

C O M P O N E N T A R R A N G E M E N T

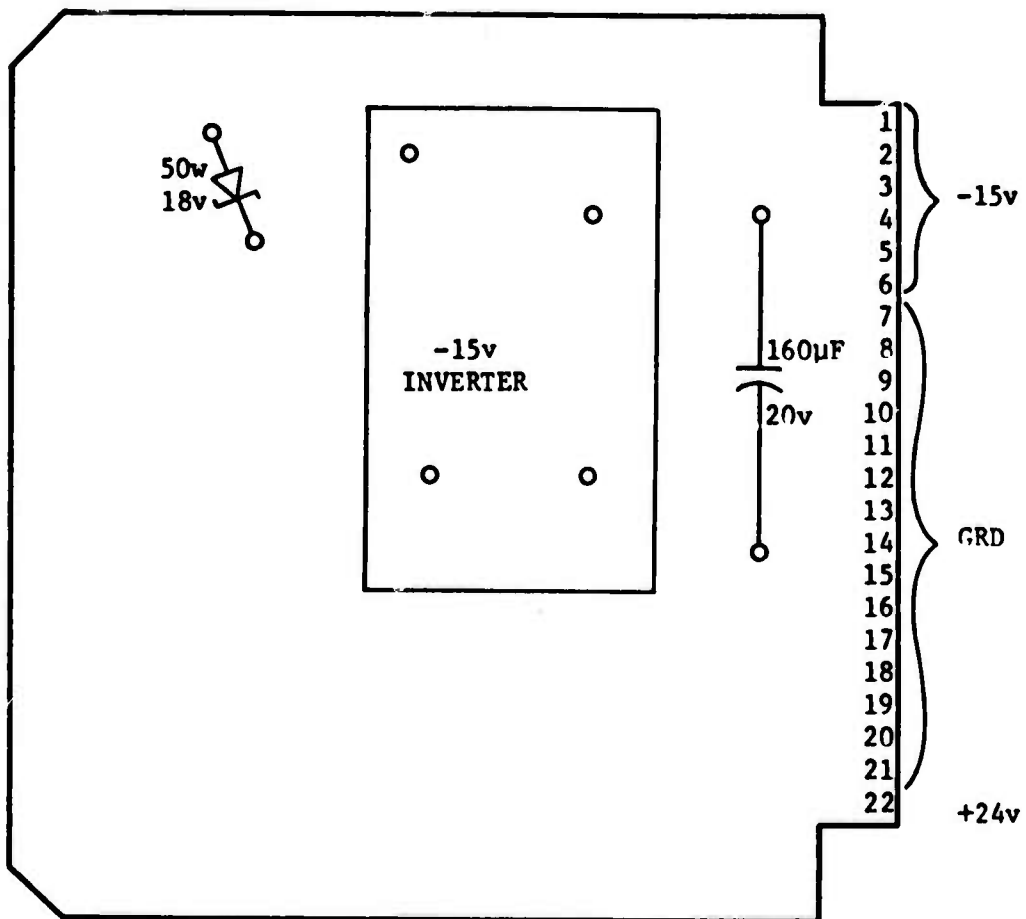

B O A R D L E T T E R E D "-P"

## VI. GENERAL PARTS LISTS

(per station)

ITEM	MANUFACTURER	MODEL #	QUANTITY
Enclosure	Circle A-W	12246 WPSC	1
Enclosure Chasis Connector	Cannon	MS3102 E14S-2P	4
Enclosure Plug Connector	Cannon	MS3106 E14S-2S	4
Enclosure Cross Members	Hand-made	To Hold Electronics	2
Electronics Rack	Thermalloy	5005-121-T	1
Card Guides	Thermalloy	5005-0111	34
Card Connectors (22 pin)	Methode	81-6044-1100-00	15
Card Connectors (70 pin)	Cambion	706-7029-01	2
Printed Circuit Cards:	Kalda Manufac.		
Preamp	" "	A	3
Filter	" "	F	3
Sample & Hold	" "	S	3
Switching Regulator	" "	+P	2
-15v Inverter	" "	-P	1
VCO (optional)	" "		1
Input/Output	" "	0	1
Wire-wrap -- Logic Board	Cambion	715-1011-01	1
A to D Converter	Analog Devices	ADC 12QL/±10v/J	1
Larse Communicator	Larse Corp.	LCS-151-55	1
Shielding	Perfection Mica	Metic Foil -15"	x5'
Interconnectors	Waldon/Molex	1545P (Plug Recep.)	5
Foam Rubber	1/2" thick	18" x 4' x 1/2"	1 piece

Logic Board (1 only)

Parts List (use wire-wrap board)

(per board)

ITEM	MANUFACTURER	MODEL #	QUANTITY
NA, B (NOR)	Texas Instr.	SN7402N	2
AA,B,C (AND)	Texas Instr.	SN7408N	3
Bd,e (Buffer)	Texas Instr.	SN7417N	2
Ba,b,c (cos/mos buffer)	RCA	CD4110AE	3
JA,B (J,K)	Texas Instr.	SN7476N	2
MA (mono)	" "	SN74121N	1
MB,C (Dual Mono)	" "	SN74123N	2
SA,B,C	Nat'l Semi.	AH0141CD	3
TA,B, -PU & CA	Cambion	702-3728-01-03	4
10k resistor	"	1/4w-carbon	9
5k resistor	"	1/4w-carbon	1
6.2k resistor	"	1/4w-carbon	1
15k resistor	"	1/4w-carbon	1
20k resistor	"	1/4w-carbon	1
470pf capacitor	"		6
1000pf capacitor	"		2

## Logic Board Parts Lists (continued)

ITEM	MANUFACTURER	MODEL #	QUANTITY
0.01 $\mu$ F Capacitor	Cambion		1
0.1 $\mu$ F Capacitor	"		1
5 $\mu$ F Capacitor	"		1
IN3595 diode	"		1
Adaptor Boards	"	702-3728-01-03	4

Preamplifier (3 each)

Parts List (use board "A")

(per board)

ITEM	MANUFACTURER	MODEL #	QUANTITY
I.C. Socket	Robinson-Nugent	LP-5178	1
Op Amp 725	Fairchild	U5T7725393	1
Test Point	H.H. Smith	Type 430	1
Insulation	1" sq.-Foam Rubber		1
R <sub>1</sub>	1%		2
R <sub>2</sub>	1%		2
R <sub>3</sub>	1%	100 $\Omega$ - 1%	3
R <sub>4</sub> (Trimpot) 100k	Bourns	3059P-1-104	1
C <sub>1</sub>	10% -20v	0.01 $\mu$ F	1
C <sub>2</sub> (Tantalum)	10% -20v	120 $\mu$ F	2

Filter (3 each)

Parts List &amp; use board "F")

(per board)

ITEM	MANUFACTURER	MODEL #	QUANTITY
1 H <sub>z</sub> - 4 pole Filter	Burr-Brown	5703-LPrL-1R00	1
I.C. Socket	Robinson-Nugent	LP-5178	1
Op Amp	Fairchild	U5T7725393	1
Test Point	H.H. Smith	Type 430	1
R <sub>1</sub>	1%	499k $\Omega$	1
R <sub>2</sub>	Carbon	10 $\Omega$	1
R <sub>3</sub>	Carbon	33 $\Omega$	1
R <sub>4</sub> (Trimpot)	Bourns	3059P-1-503	1
C <sub>1</sub> (Metalized Mylar)	Paktron ( $\pm$ 10%)	7 $\mu$ F -100v	1
C <sub>2</sub>		0.05 $\mu$ F	1
C <sub>3</sub>		0.02 $\mu$ F	1

Sample & Hold (3 each)

## Parts List (use board "S")

(per board)

ITEM	MANUFACTURER	MODEL #	QUANTITY
Sample & Hold Module	Analog Devices	SHA III	1
I.C. Socket	Robinson-Nugent	LP-5178	1
Op Amp 741	Fairchild	U5B7741393	1
Test Point	H.H. Smith	Type 430	1
R <sub>1</sub>	1%	See Drawing	1
R <sub>2</sub>	1%	10k $\Omega$	1
R <sub>3</sub>	Carbon	8.66k $\Omega$	1
R <sub>4</sub> (Board S3 only)	Carbon	10k $\Omega$	1
R <sub>5</sub>	Carbon	300 $\Omega$	1
R <sub>6</sub>	Carbon -1/2w	100 $\Omega$	1
R <sub>7</sub> (Trimpot)	Bourms	3059P-1-103	1
C <sub>1</sub> (Tantalum)	10% -20v	120 $\mu$ F	2
C <sub>2</sub> (Board S3 only)	10% -20v	0.01 $\mu$ F	1

Input/Output (I/O) (1 each)

## Parts List (use board "D")

ITEM	MANUFACTURER	MODEL #	QUANTITY
F1 - Fuseholder	Buss	4405	1
F1 - Fuse	1A - 1/4" x 1 1/4"	1A	1
SG1,2, & 3 - Spark Gaps	Signalite	CG-75	3
Spark Gap Holders	Signalite	Con-Gap-Holder	3
D1 - Zener Diode (30v - 50w)	Motorola	IN2823A	1
C1	30v	110 $\mu$ F	1
Ti (600 $\Omega$ - 1 to 1 Isolation)	UTC	S0-15P	1
D2 - Zener Diode (10v - 1w)	(Any value >5v)	(IN3020B)	4

Switching Regulator (2 each)

Parts List (use board "P")

(per board)

ITEM	MANUFACTURER	MODEL #	QUANTITY
I.C. Socket	Robinson-Rugent	LP-5178	1
Voltage Regulator	Nat'l Semi	LM-305H	1
L1 - Core	Arnold Eng.	A930157-2	1
Q <sub>1</sub>	Motorola	2N2905	1
Q <sub>2</sub>	Motorola	2N3445	1
D <sub>1</sub>	Motorola	IN3880	1
D <sub>2</sub> (5v board)	Motorola	IN4562A	1
D <sub>2</sub> (15v board)	Motorola	IN2816A	1
R <sub>1</sub>	1%	see drawing	1
R <sub>2</sub>	1%	see drawing	1
R <sub>3</sub>	Carbon	22Ω	1
R <sub>4</sub>	Carbon	68Ω	1
R <sub>5</sub>	Carbon 1/2w	50Ω	1
R <sub>6</sub>	Carbon	3mΩ	1
C <sub>1</sub> (Tantalum)	20v	see drawing	1
C <sub>2</sub> (Tantalum)	20v	160μF	1
C <sub>3</sub>	30v	100μF	1

-15v Inverter (1 each)

Parts List (use board "P")

(per board)

ITEM	MANUFACTURER	MODEL #	QUANTITY
-15v Inverter Module	Mil Electronics	SS445	1
D <sub>1</sub> - Zener Diode (18v - 50w)	Motorola	IN2816A	1
C <sub>1</sub> - (Tantalum)	20v	160μF	1