

AD-776 356

THREE-DIRECTIONAL LOAD TRANSDUCER

Anthony R. Clemente, et al

Bolt, Beranek and Newman, Incorporated

Prepared for:

Army Natick Laboratories

April 1973

DISTRIBUTED BY:

NTIS

National Technical Information Service
U. S. DEPARTMENT OF COMMERCE
5285 Port Royal Road, Springfield Va. 22151

UNCLASSIFIED

SECURITY CLASSIFICATION OF THIS PAGE (When Data Entered)

REPORT DOCUMENTATION PAGE		READ INSTRUCTIONS BEFORE COMPLETING FORM
1. REPORT NUMBER 74-28-GP	2. GOVT ACCESSION NO.	3. RECIPIENT'S CATALOG NUMBER AD 776 356
4. TITLE (and Subtitle) THREE-DIRECTIONAL LOAD TRANSDUCER		5. TYPE OF REPORT & PERIOD COVERED Final Report for Period 21 Apr 72 to 21 Jul 72
		5. PERFORMING ORG. REPORT NUMBER 2538
7. AUTHOR(s) Anthony F. Clemente James B. Blackwell Richard Madden Paul J. Remington		8. CONTRACT OR GRANT NUMBER(s) DAAG 17-72-C-0116
9. PERFORMING ORGANIZATION NAME AND ADDRESS Bolt Beranek and Newman Inc. 50 Moulton Street Cambridge, Massachusetts 02138		10. PROGRAM ELEMENT, PROJECT, TASK AREA & WORK UNIT NUMBERS 6.2; 1G762713DJ40; 35
11. CONTROLLING OFFICE NAME AND ADDRESS U. S. Army Natick Laboratories (STSNL-GSO) Kansas Street Natick, Massachusetts 01760		12. REPORT DATE April 1973
		13. NUMBER OF PAGES 39
14. MONITORING AGENCY NAME & ADDRESS (if different from Controlling Office)		15. SECURITY CLASS. (of this report) Unclassified
		15a. DECLASSIFICATION/DOWNGRADING SCHEDULE
16. DISTRIBUTION STATEMENT (of this Report) Approved for public release; distribution unlimited.		
17. DISTRIBUTION STATEMENT (of the abstract entered in Block 20, if different from Report)		
18. SUPPLEMENTARY NOTES Reproduced by NATIONAL TECHNICAL INFORMATION SERVICE U. S. Department of Commerce Springfield, VA 22151		DDC MAR 27 1974 RESOLVED B
19. KEY WORDS (Continue on reverse side if necessary and identify by block number) Key Words on reverse side.		
20. ABSTRACT (Continue on reverse side if necessary and identify by block number) The report describes a three-directional load transducer to be used for measuring loads in tent tie downs. Included in the report are mechanical descriptions of the parts of the transducer and their functions, a method for determining approximate transducer sensitivity, a discussion of bridge wiring, calibration procedures, and the results of the calibration. An appendix presents raw calibration data.		

UNCLASSIFIED

UNCLASSIFIED

SECURITY CLASSIFICATION OF THIS PAGE(When Data Entered)

19. Key Words:	Link A		Link B		Link C	
	Role	Wt	Role	Wt	Role	Wt
Calibrating		8				
Measuring		8				
Loads		9				
Air Supported Structures		9				
Tents		9				
Transducer		10	9		9	
Load Transducer		10	9		9	
Load Stabilizer		10	9		9	
Three Directional		0	0		0	
Mechanical Properties			8			
Operations Research			8			
Loading Operations			8			
Data					8	
Determination					4	
Systems Analysis					8	
Sensitivity (Transducers)					4	
Wiring (Bridge)					9	
Calibration Procedures					9	
Solutions					9	

ia'

UNCLASSIFIED

SECURITY CLASSIFICATION OF THIS PAGE(When Data Entered)

FOREWORD

This report is prepared by Bolt, Beranek, & Newman, Inc. under Exploratory Development Project 1G762713DJ40, Clothing and Equipment Technology - Task 36, Studies in the Mechanics of Tentage, Materials and Structures for the U.S. Army Natick Laboratories, Natick, MA. Previous work was conducted in-house by the U.S. Army Natick Labs during the period of June 1970 to March 1972.

The transducer described in this report is a 2,000-lb. three directional load transducer with a maximum cross-talk of 1%. Production units meeting all requirements of this technical report will be used to determine the lift, drag, and over-turning moment of two air-supported tents to be tested under controlled wind conditions up to 110 mph. Mr. Jack M. Siegel of the General Equipment & Packaging Laboratory at the U.S. Army Natick Laboratories was the Project Officer for this effort. Dr. Richard Madden was the Program Manager, and Mr. Anthony Clemeche was the Principal Investigator for Bolt, Beranek and Newman. Appreciation is expressed to Dr. Earl Steeves, Engineering Sciences Division, GEPL and Mr. Arthur Murphy, Airdrop Engineering Laboratory, for their valuable input and comments throughout the development program, and to Mr. Albert Langevin, Engineering Evaluation Office, GEPL for his diligent efforts in testing the prototype and his valuable comments related thereto.

TABLE OF CONTENTS

	page
LIST OF FIGURES	v
SECTION 1. INTRODUCTION	1
2. MECHANICAL DESCRIPTION	5
3. ELEMENT SENSITIVITY	13
4. ELIMINATION OF CROSSTALK	16
5. CALIBRATION OF THE THREE-DIRECTIONAL LOAD TRANSDUCER	19
5.1 Vertical Direction	19
5.2 Horizontal Direction	19
5.3 Temperature Test	19
5.4 No-Load Drift Test	20
5.5 Wind Drift Test	20
6. EVALUATION REPORT ON THE THREE- COMPONENT LOAD TRANSDUCER	21
6.1 Calibration	21
6.2 Drift Amplitude	24
6.3 Cyclic Loadings	28
6.4 Temperature Stability	28
6.5 Stability Under Wind Loadings	28
SUMMARY	29
APPENDIX: RAW CALIBRATION DATA	30

LIST OF FIGURES

	page
Figure 1. Three component load transducer	2
2. Three component load transducer with cover removed	3
3. Unassembled three component load transducer	6
4. Schematic of force measuring element ..	8
5. Schematic of transversely deflected measuring element	9
6. Measurement beam	12
7. Measuring element sensitivity	14
8. Combined bridge for horizontal elements	17
9. Calibration of vertical element	22
10. Vertical element calibration	23
11. Calibration of horizontal elements	25
12. Horizontal (H_{x1}, H_{x2}) element calibration	26
13. Horizontal (H_{y1}, H_{y2}) element calibration	27
A.1. Output of x-axis element	31
A.2. Output of y-axis element	32
A.3. Output of z-axis element	33

Preceding page blank

THREE-DIRECTIONAL LOAD TRANSDUCER

1. INTRODUCTION

This report describes a three-directional load transducer developed for U.S. Army Natick Laboratories for the purpose of measuring loads in tent tie downs. A photograph of the transducer is presented as Fig. 1. Measuring the three components of force in a tent tie down offers some unique problems which render commercially available transducers unsuitable. For example, the tent tie down is not rigid; rather it is a cable whose orientation changes as a function of local tent deflection at the cable attachment. The transducer must therefore be fitted with a swivel which will allow the cable attachment to align itself with the instantaneous direction of the tie down without introducing spurious loads or moments. We therefore specifically designed the transducer for the task at hand, and although it may have a number of alternate applications, our discussion will be restricted to its use in tent tie down force measurements.

The transducer has a rated load capacity of 8.96 kN (2000 lb) in each of its measuring directions. Loads from the tie down cable are applied to the transducer through a dowel pin located at the intersection of lines drawn through the geometric center of each force-measuring element. The center section of the transducer is an aircraft bearing which allows the dowel pin to swivel to align itself with the instantaneous direction of the tie down. Loads applied to the bearing are transferred to the base through the measuring elements. The stiffness of the elements in directions perpendicular to their measuring axis is small in order to attenuate crosstalk between measuring channels. Figure 2 is a photograph of the transducer with the cover removed. It illustrates the swivel, the dowel pin attachment, and the measuring elements. The transducer coordinate system is also shown on the figure.

Each of the measuring elements is equipped with a full bridge that consists of four 120-ohm strain gauges. The four active elements of each bridge are close together to reduce thermal problems. The bridge is mounted on a double cantilever section of the measuring element which is subjected to bending. To increase sensitivity under these bending conditions, two strain gauges are mounted on the tension section of the bending member and two are mounted on the compression section.

The sensitivity of the vertical measuring element is approximately twice that of the horizontal ones, because horizontal loads are shared by two measuring elements. In addition to being isolated mechanically, crosstalk is attenuated

electrically. The bridges of the two horizontal measuring elements in a particular direction share the same power supply, and the output leads are connected so that their output voltages are inverted (i.e., the resulting output voltage is the difference between the output voltage of the two elements). Both bridges are balanced as a single unit.

The remainder of this report contains mechanical descriptions of the parts of the transducer and their functions, a method for determining approximate transducer sensitivity, a discussion of transducer calibration procedures, and the results of calibration.

2. MECHANICAL DESCRIPTION

The three-component load transducer is shown disassembled in Fig. 3. To keep thermal problems to a minimum, the major components are made of the same material. All parts except the case and cover (which are aluminum), the bearing, and the swivel are made from 17-4 PH stainless steel. This material has a low coefficient of thermal expansion and is also ideally suited for force balance applications in that after heat treatment it has an extended linear elastic range. The swivel is constructed of 303 stainless steel to match more closely the thermal characteristics of the bearing, thereby insuring a tight fit in spite of temperature changes.

The load enters the transducer through the dowel pin in the swivel, travels through the swivel into the bearing, then through the bearing and into the bearing retainer. Loads from the bearing retainer go to the base plate either through the vertical element support and the vertical measuring element or through the horizontal measuring elements and then through the support posts. The transducer has been designed so that the center of the dowel pin in the swivel (i.e., the point of application of cable load) is at the geometric center of the five measuring elements. This has been done so that the applied load does not exert any moments on the measuring elements. The swivel and bearing allow the dowel pin to rotate in the horizontal plane and thereby to align itself with the instantaneous direction of a cable tie down. Since the swivel assembly is somewhat massive and since the bearing is not frictionless, the useful range of swivel operation is restricted to low frequencies.

Given these load paths, it is clear that the greatest sensitivity occurs when the horizontal measuring elements are weak springs relative to a vertical load as well as to horizontal loads perpendicular to their axes, and the vertical measuring element is weak relative to horizontal loads. Thus, the major portion of a particular load is carried by the appropriate measuring element. To illustrate this mathematically, we can assume that the measuring elements are springs and that they are all connected in parallel. Relative to a vertical load, the horizontal measuring elements in the x and y directions have spring stiffnesses of k_{xv} and k_{yv} , and the vertical has k_{vv} . The combined vertical stiffness K_v is then given by

$$K_v = k_{vv} + 2k_{xv} + 2k_{yv} .$$

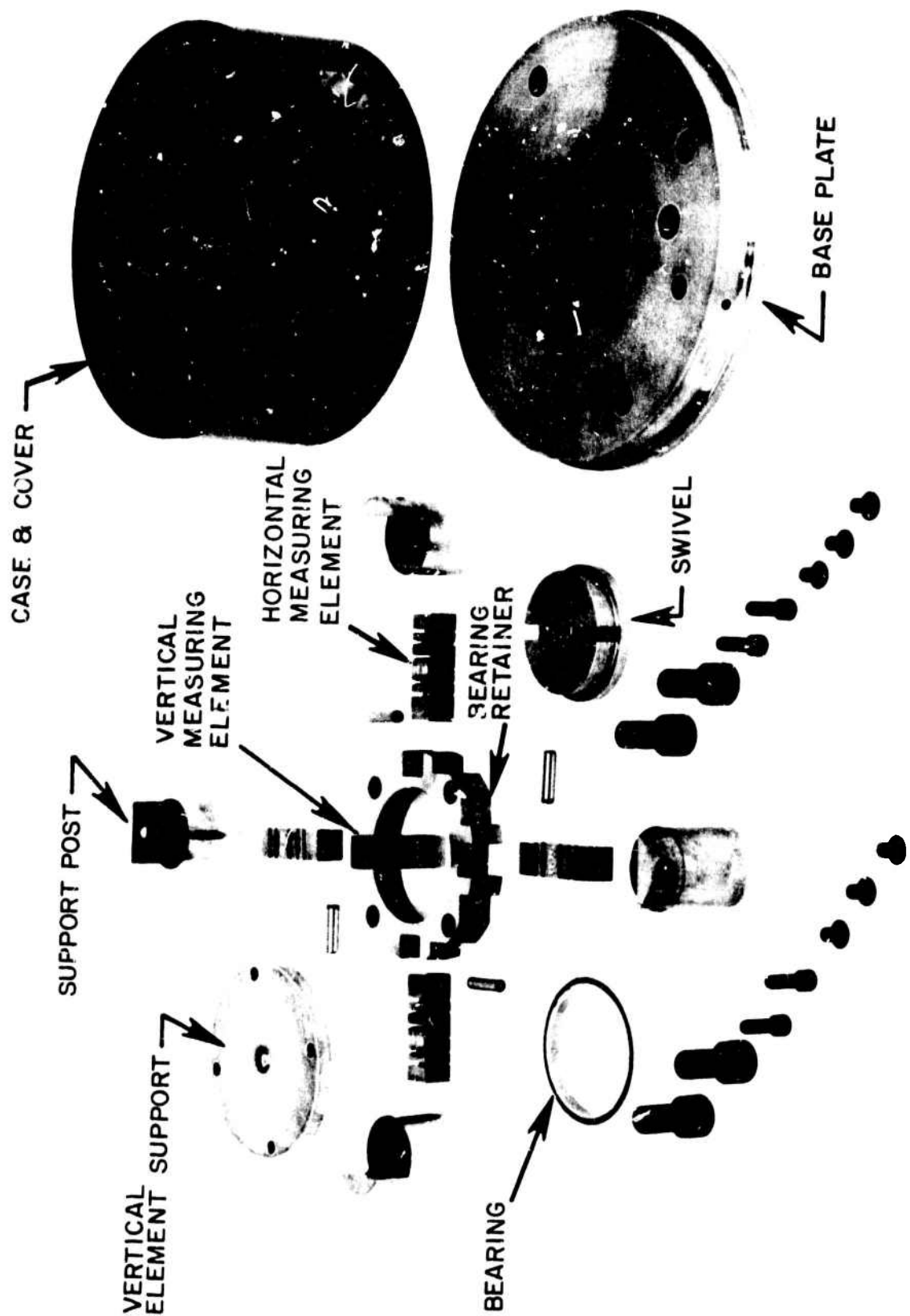

FIG. 3. UNASSEMBLED THREE COMPONENT LOAD TRANSDUCER

(The 2 results from the fact that each horizontal direction has two measurement beams.) Assuming further that the vertical stiffness of all horizontal measuring elements is identical gives

$$K_v = k_{vv} \left(1 + 4 \frac{k_{xv}}{k_{vv}} \right) \quad (1)$$

Equation 1 shows that if we desire 99% of the vertical load to travel through the vertical measuring element, then the vertical stiffness of the horizontal elements must be less than .25% of the stiffness of the vertical element. Similar mathematical analyses may be performed for the two horizontal directions.

In the present transducer, the stiffness of the measuring elements in directions normal to their axes has been attenuated by providing the elements with flexures. The sketch of a measuring element in Fig. 4 may be used to explain its operation. The major areas of interest are the four flexures and the instrumented beam at the center.

The element measures force applied along its axis. To examine the mechanism for crosstalk let us consider a force applied perpendicular to the axes. The stiffness in bending for loads applied perpendicular to the axis is controlled by the measurement beam supports and by the two flexures whose webs run perpendicular to the load. To prevent crosstalk, the measurement beam should deflect much less when it is deflected by loads perpendicular to its axis than when it is deflected parallel to its axis.

To understand these concepts more completely, consider the schematic representation (Fig. 5) of a measuring element being deflected a distance δ perpendicular to its axis. Points (1) and (3) represent the flexure webs and point (2) represents the measurement beam. The design of the element is such that most of the deformation takes place at the measurement beam and the flexure. As a result, we can represent the element as 3 rigid beams connected by torsional springs at positions (1), (2) and (3) with stiffnesses K_F and K_B of the flexure and measurement beam, respectively. The force at the end of the element can then be expressed in terms of the angular rotations about the flexures and measurement beam by

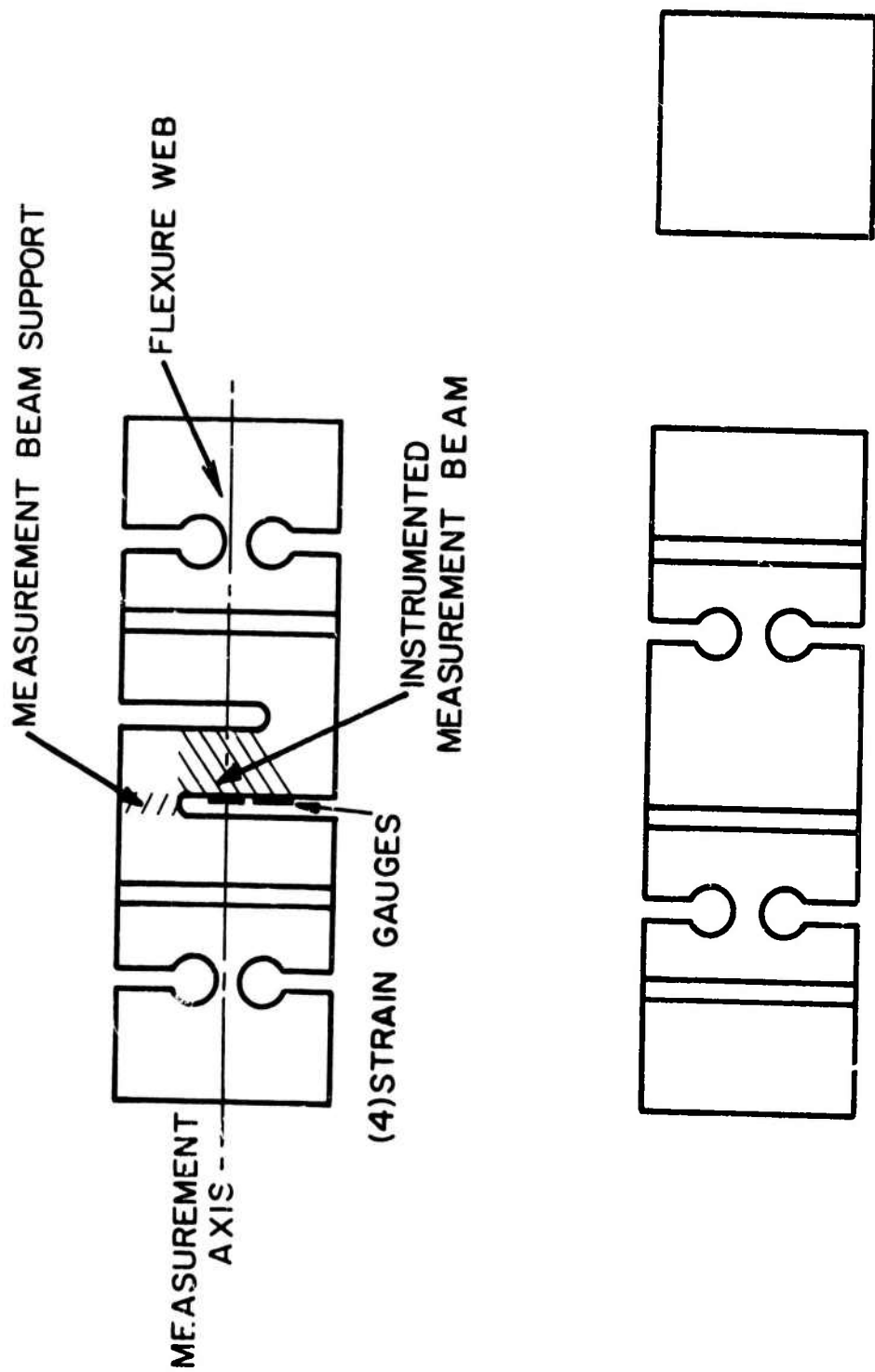

FIG. 4 SCHEMATIC OF FORCE MEASURING ELEMENT

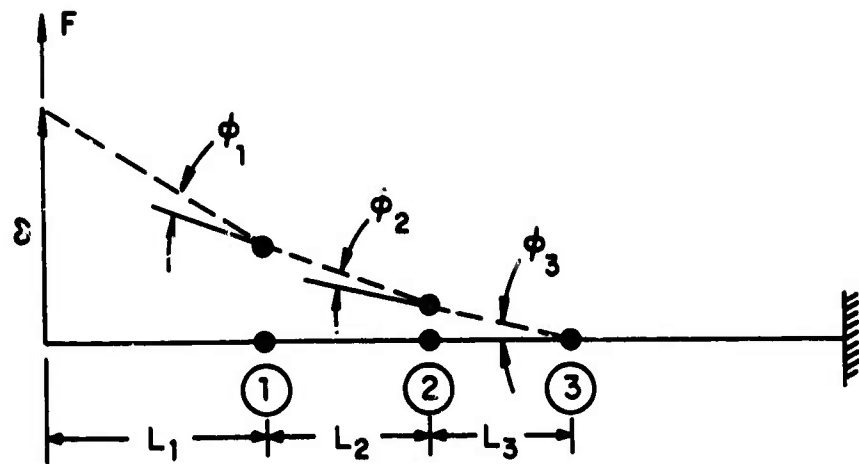

FIG. 5. SCHEMATIC OF TRANSVERSELY DEFLECTED MEASURING ELEMENT

$$\begin{aligned}
L_1 F &= K_F \phi_1 \\
(L_1 + L_2) F &= K_B \phi_2 \\
(L_1 + L_2 + L_3) F &= K_F \phi_3 \quad , \quad (2)
\end{aligned}$$

and the total deflection at that point may be written

$$\delta \cong L_1 \phi_1 + L_2 \phi_2 + L_3 \phi_3 \quad . \quad (3)$$

To reduce crosstalk, we would like ϕ_2 to be as small as possible. Intuitively, one would expect this to be easily accomplished by making $K_B \gg K_F$. If the flexures are indeed much less stiff than the measuring element, then by solving Eqs. 2 and 3 one finds that the total transverse stiffness of the measuring element for a vertical element, for example K_V , is defined by

$$F = K_V \delta \quad ,$$

and

$$K_V \cong \frac{K_F}{(L_1^2 + L_1 L_3 + L_2 L_3 + L_3^2)} \quad . \quad (4)$$

The angular rotation at the measurement beam becomes

$$\frac{\phi_2}{\delta} = \frac{L_1 + L_2}{(L_1^2 + L_1 L_3 + L_2 L_3 + L_3^2)} \frac{K_F}{K_B} \quad . \quad (5)$$

It is apparent on examining Eq. 4 that to reduce ϕ_2 and, hence, crosstalk, one should make $K_F \ll K_B$, make the element as long as practical, make the distance between the transversely loaded end of the element and the measuring beam as short as possible, and also make the distance from the measuring beam to the flexure at position 3 as long as possible. In general, though, space and strength constraints predetermine the spacing between flexures and measuring beams, leaving only the design of the rotational stiffness of the flexures and measurement beam as variables.

Assuming that the predominant contributor to the bending stiffness is the moment of inertia of each of these sections, then the thickness of the web in the flexure and the height

of the measuring beam support are the parameters of interest. Since the moment of inertia depends on thickness cubed, large changes in stiffness are obtained by thinning or thickening either of these two sections. Note, however, that thickening the measurement beam support can lead to considerable reduction in sensitivity. Thus, the flexure is the controlling area for reducing stiffness in directions normal to the axis of the element. The flexure is designed so that its cross sectional area can carry the required maximum load. The holes drilled on either side of the flexure should be as large as possible to attenuate the stress concentration factor.

The measuring section is basically a double cantilever beam which bends into the form of an S when under load. Figure 6a shows a three-dimensional view of the measuring section under load. Figure 6b shows the moment diagram for the element under load. The dashed curves (near the end of the element over the support) illustrate that the moment is in reality distributed over the support. As shown on Fig. 6a, a full bridge of strain gauges is placed on the measuring beam, two on the tension section and two on the compression section. The reason for placing a full bridge of gauges on this element in this manner is, as explained more fully in the next section, that the output is increased. An additional advantage is that locating the entire bridge in the same vicinity offers a certain measure of thermal compensation.

An additional consideration entering into the transducer design is that the bearing retainer, the vertical element support, the support posts, and the base plate must all be extremely stiff in order to keep their deflections under load to a minimum. If these components are too flexible, significant crosstalk between measuring elements will result.

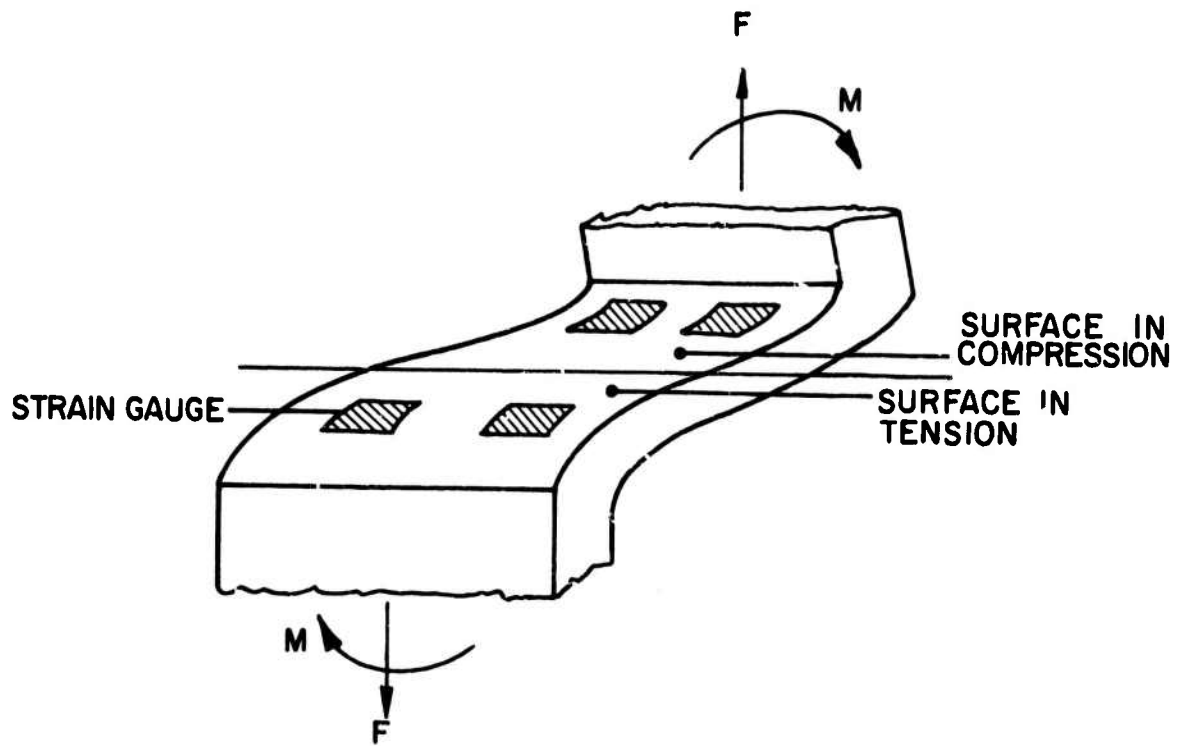

(a) MEASURING BEAM UNDER LOAD

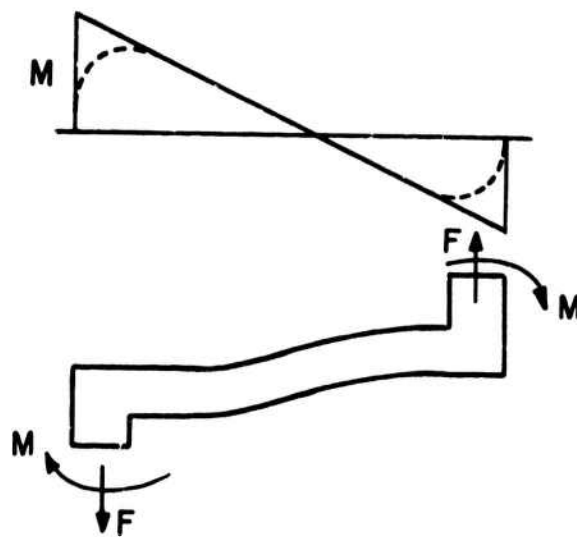

(b) MOMENT DIAGRAM

FIG. 6. MEASUREMENT BEAM

3. ELEMENT SENSITIVITY

This section contains an extremely simplified method of calculating the electrical sensitivities of the elements. It assumes that the measurement beam acts like a double cantilever and that the strain gauges are mounted on the element in the linear moment area. Sensitivities predicted by the method are within a factor of 2 of the sensitivities measured from actual elements.

Figure 7a is a diagram of the Wheatstone bridge used for measuring strain. When a voltage V_0 is applied, the output voltage ΔE is zero, provided that the bridge is initially in balance (i.e., $R_1 R_4 = R_2 R_3$). The assumption that all initial resistances are the same automatically satisfies this equation ($R_1 = R_2 = R_3 = R_4 = R$). Under load, the resistances of the strain gauges change, and the resultant output is given by

$$\frac{\Delta E}{V_0} = \frac{1}{4} \left(\frac{\Delta R_1}{R} - \frac{\Delta R_2}{R} + \frac{\Delta R_3}{R} - \frac{\Delta R_4}{R} \right) . \quad (6)$$

Assuming now that strain gauges R_1, R_3 are placed on the tension section, that strain gauges R_2, R_4 are placed on the compression section, that they are equidistant from the zero moment line on the center of the beam, and that they each have the same sensitivity to strain (i.e., $\Delta R_1 = \Delta R_2 = \Delta R_3 = \Delta R_4 = \Delta R$) gives

$$\frac{\Delta E}{V_0} = \frac{\Delta R}{R} . \quad (7)$$

Assuming a gauge factor of 2 gives

$$\frac{\Delta E}{V_0} = 2\epsilon , \quad (8)$$

where ϵ is the local strain at the center of the strain gauge. Figure 7b shows the loads on the measuring element and the position of the strain gauges. From elementary theory, we calculate the stress at the center of one of the gauges as

$$S = \frac{Mt}{2I} = \frac{(FX_0)}{\left(\frac{wt^3}{12}\right)} \frac{t}{2} = \frac{6FX_0}{wt^2} , \quad (9)$$

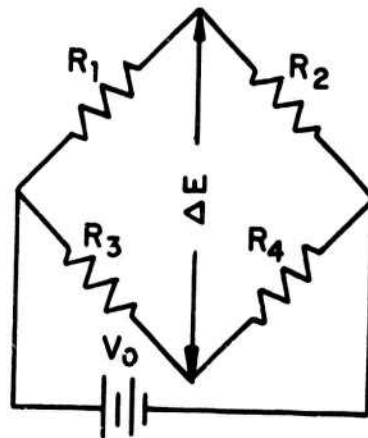

(a) WHEATSTONE BRIDGE

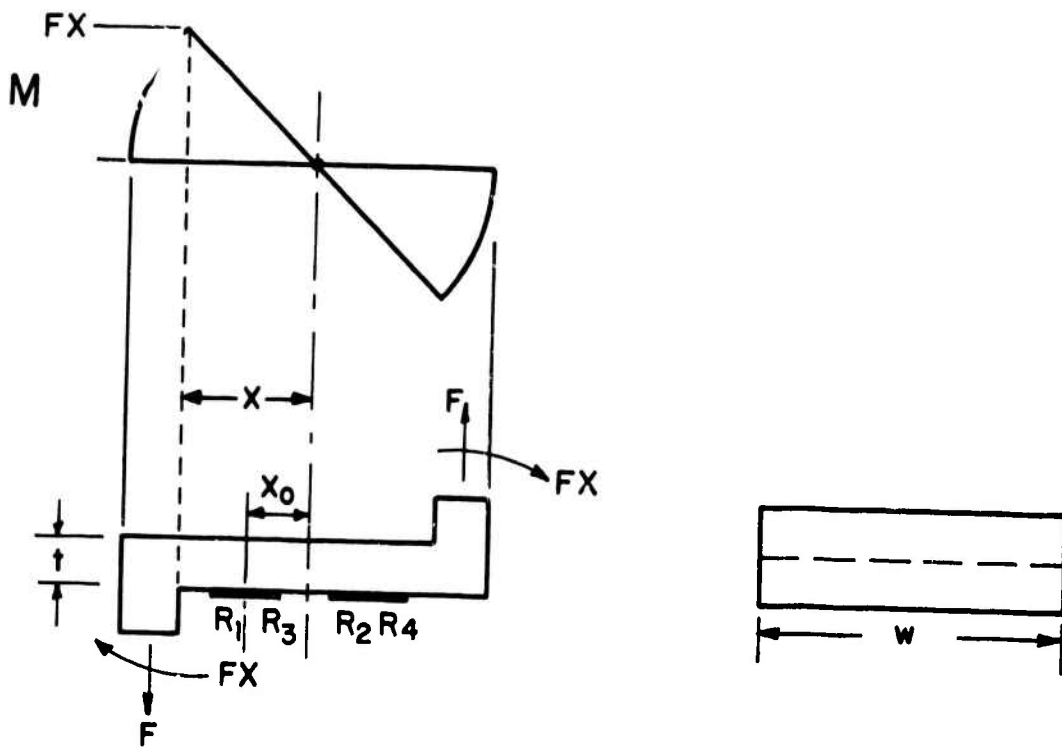

(b) LOAD ON MEASURING ELEMENT

FIG. 7. MEASURING ELEMENT SENSITIVITY

where S is the stress, M is the moment, I is its moment of inertia, F is the applied force, X_0 is the distance from the center of the measuring element to the center of the strain gauge, and w and t are the width and thickness of the measuring element, respectively. Letting $S = E\epsilon$ and substituting into Eq. 8 gives

$$\frac{\Delta E}{V_0} = \frac{12FX_0}{wEt^2} ,$$

or, in the desired form,

$$\frac{\Delta E}{FV_0} = \frac{12X_0}{wEt^2} . \quad (10)$$

For the element under consideration,

$$X_0 \approx .182 \text{ cm } (.072 \text{ in.})$$

$$w = 1.54 \text{ cm } (.624 \text{ in.})$$

$$t = .425 \text{ cm } (.168 \text{ in.})$$

$$E = 200 \frac{\text{GN}}{\text{m}^2} (29 \times 10^6 \text{ psi}) .$$

Therefore, the sensitivity should be

$$\frac{\Delta E}{FV_0} = .38 \text{ } \mu\text{V/V/N} = 1.7 \text{ } \mu\text{V/V/lb} .$$

Actual measuring elements have a sensitivity between .2 and .31 $\mu\text{V/V/N}$ (.9 and 1.4 $\mu\text{V/V/lb}$). The reasons for the reduction in sensitivity are that a section of the strain gauge bridge lies over the measurement beam support (see Fig. 4) and that the gauges are not symmetrically placed with respect to the zero moment line.

In the next section, we discuss the electrical wiring used to attenuate crosstalk beyond that possible by using mechanical means alone.

4. ELIMINATION OF CROSSTALK

In the original design of the transducer, strain gauge bridges were applied to only two of the horizontal measuring elements. Testing the device showed that the horizontal-to-horizontal crosstalk and the vertical-to-horizontal crosstalk, although acceptable for most applications, did not meet the desired $\leq 1\%$ specification. Referring to Fig. 2, we note that if a load is applied in the y direction, one of the y measuring elements goes into compression and the other into tension, whereas both of the x measuring elements go into tension. Using this as an example and considering all the various types of crosstalk which occur in the horizontal measuring channels, one notes that the sign of the crosstalk voltage output is the same for both opposing measuring elements and that the sign of the desired signal voltage is opposite. It is then clear that crosstalk can be greatly attenuated if we wire opposing bridges together and invert either the polarity of the power supply or the output leads. Figure 8a shows an electrical schematic with the output leads reversed. The tension and compression strain gauges for loading along the measurement axis for the elements under consideration are indicated on the figure. Figure 8b is an equivalent bridge for the circuit in Fig. 8a. Note that the bridge resistance has been reduced from R ohms to R/2 ohms. Bridge balancing for the combined circuit is identical with that used for a single bridge.

Consider a typical leg of the bridge:

$$R'_{12} = \frac{R_{12}R_{21}}{R_{12}+R_{21}}$$

$$R'_{12} + \Delta R'_{12} = \frac{(R_{12} + \Delta R_{12})(R_{21} + \Delta R_{21})}{R_{12} + R_{21} + \Delta R_{12} + \Delta R_{21}} \cdot$$

Letting $R_{12} = R_{21} = R$ and $\Delta R_{12} = \Delta R_{21} = \Delta R_2$ gives

$$R'_{12} = \frac{R}{2}$$

$$\Delta R'_{12} = \frac{R^2 + 2R\Delta R_2 + \Delta R_2^2}{2R + 2\Delta R_2} - \frac{R}{2} = \frac{\Delta R_2}{2}$$

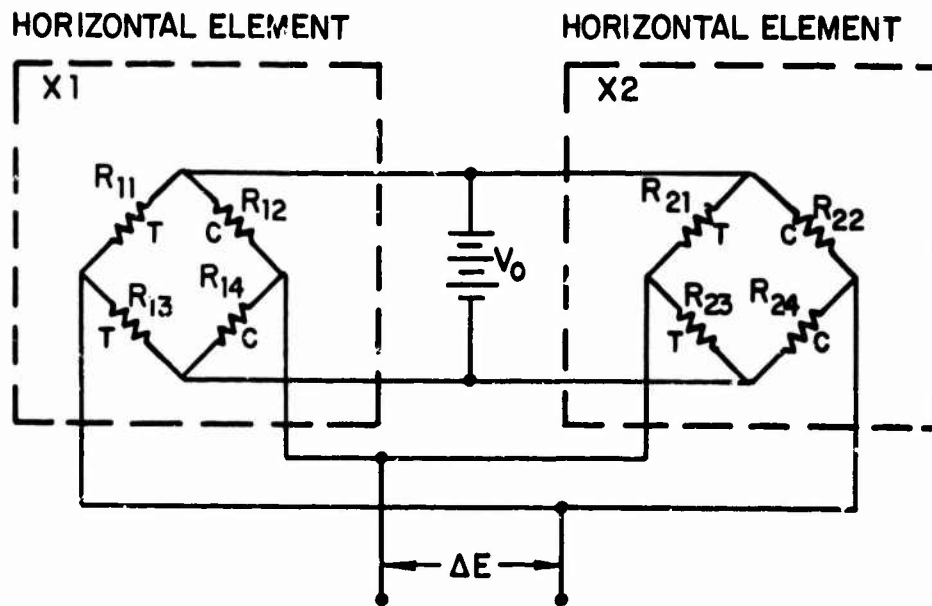

(a) WIRING OF OPPOSING HORIZONTAL ELEMENTS

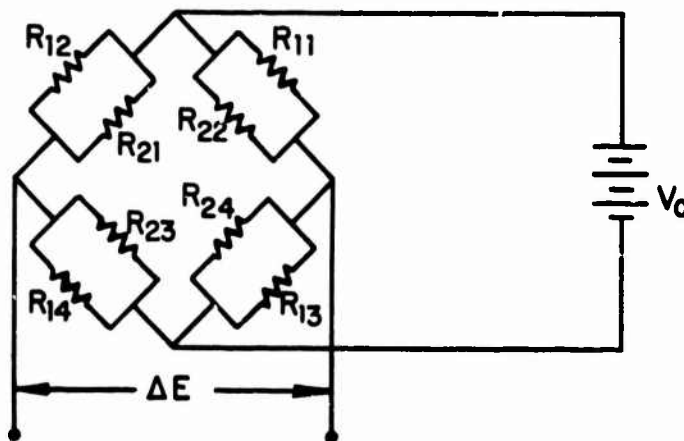

(b) EQUIVALENT SINGLE BRIDGE

FIG. 8. COMBINED BRIDGE FOR HORIZONTAL ELEMENTS

or

$$\frac{\Delta R'_{12}}{R'_{12}} = \frac{\Delta R_2}{R} \quad . \quad (11)$$

Substituting Eq. 11 and similar equations for all other elements into Eq. 6 gives an expression identical to Eq. 2:

$$\frac{\Delta E}{V_0} = \frac{1}{4} \left(\frac{\Delta R_1}{R} - \frac{\Delta R_2}{R} + \frac{\Delta R_3}{R} - \frac{\Delta R_4}{R} \right) \quad .$$

Assuming that all resistance changes are the same and that the signs of all resistance changes are the same as those given in Fig. 8 for loads applied along the measuring axis of the elements shows that the combined bridge has the same sensitivity as a single bridge. On the other hand, if a load is applied in a perpendicular direction then $\Delta R_{12} = -\Delta R_{21}$ and therefore

$$\frac{\Delta E}{V_0} = \left| \frac{\Delta R^2}{2R} \right| \approx 0 \quad ,$$

thus giving virtually zero crosstalk. It should be remembered, however, that the opposing horizontal elements share load equally; therefore, each element sees only one-half of a given load. Thus, the horizontal elements appear to be half as sensitive as the vertical ones.

5. CALIBRATION OF THE THREE-DIRECTIONAL LOAD TRANSDUCER

The three-directional load transducer is a precision instrument and, therefore, a great deal of care must be exercised both in performing the calibration and in selecting the remaining components of the measuring system. Of particular importance is alignment of the transducer with the direction of the applied force. Poor alignment will result in effective crosstalk between channels. Effective crosstalk errors are proportional to the sine of misalignment angle and, therefore, misalignment must be kept well below .01 rad ($1/2^\circ$) if it is desired to measure actual crosstalk on the order of 1%. One must also insure that the entire measurement chain is capable of measuring the lowest levels expected (1-2 μ V) and that all amplifiers, power supplies, and recording equipment are virtually free from drift.

This section describes a calibration procedure which has been designed based on the ultimate use of the transducer. The calibration evaluates sensitivity, zero shift, hysteresis, drift, thermal stability, and stability under wind loading.

5.1 Vertical Direction

Load the transducer in increments of no more than .896 kN (200 lb) from 0 to 8.96 kN (2000 lb), and record the output from the vertical channel for calibration and from the two horizontal channels for crosstalk. Release the load and measure zero shift in all channels to record hysteresis. Repeat the loading to 8.96 kN (2000 lb) a total of 15 times and record the output from all channels. The zero shift should be less than 1% of the full-scale output, and the full-scale output should not vary by more than 1%.

5.2 Horizontal Direction

Perform loading increments and cyclic loading in the same manner as specified for the vertical direction.

5.3 Temperature Test

Subject the transducer (under no-load conditions) to a temperature difference of 28° K (50° F) in an oven and record output data in all three measuring directions. Allow sufficient time for the temperature of the balance to become uniform.

5.4 No-Load Drift Test

Power the transducer and leave it in a controlled environment (under no-load conditions) at $294 \pm 5.6^\circ \text{K}$ ($70 \pm 10^\circ \text{F}$) for a period of 96 hours, and record the output in all three measurement channels.

5.5 Wind Drift Test

Subject the transducer (under no-load conditions) to wind loadings at velocities of 15.7, 31.3 and 49.2 m/s (30, 70 and 110 mph) for a period of 5 min. Record the output from all three measurement channels.

6. EVALUATION REPORT ON THE THREE-COMPONENT LOAD TRANSDUCER

Testing of the three-component force balance was conducted at BBN. Loadings were applied to the balance in three mutually perpendicular directions using a Timius Olsen "Cal Tester" which has a range from 0 to 22.4 kN (5000 lb). Prior to testing the assembled balance, a number of tests were conducted on various subcomponents. Of particular interest were the following results.

1. The central bearing will withstand an axial load of 19.7 kN (4400 lb) without damage.

2. The measuring elements will withstand loads in their measuring directions of 17.9 kN (4000 lb) without plastic deformation.

Loads on the assembled balance were limited to 13.4 kN (3000 lb) to ensure integrity of the strain gauge bridges.

During all tests, the strain gauge bridges were powered by a Power Designs Inc. Model 2005 precision power source. Voltage was maintained at 2 V at the transducer connection and the unit drew approximately 80 mA (16 mA per bridge). A supply voltage of no more than 2 V is recommended to avoid heating of the strain gauge circuits. Signals from the strain gauge bridges were fed into B&F Model 2423 signal conditioners and then into Dana Model 2850 dc amplifiers set at 0.01 Hz bandwidth.* The calibration consisted of continuously loading the balance in three perpendicular directions from 0 to 8.96 kN (2000 lb). During each test, the output from all channels was measured continuously.

6.1 Calibration

Figure 9 shows the force balance in position on the "Cal Tester" for calibration of the vertical element. The calibration is plotted as millivolt output per volt input as a function of applied load in pounds as shown in Fig. 10.

*The equipment cited is typical of that required to perform the measurement task and does not constitute an official endorsement or approval of the use of such commercial hardware by either BBN or U.S. Army Natick Laboratories.

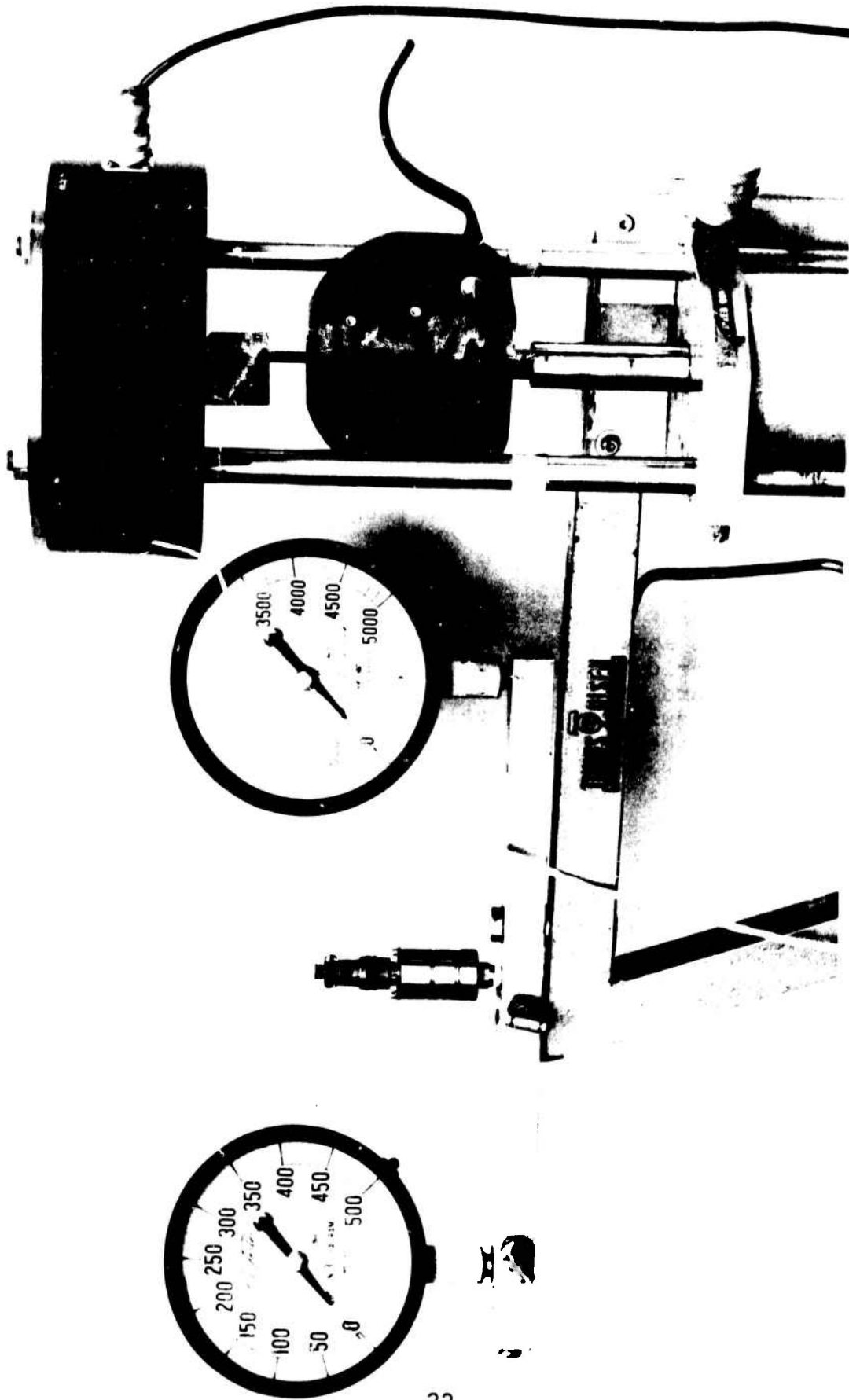

FIG. 9. CALIBRATION OF VERTICAL ELEMENT

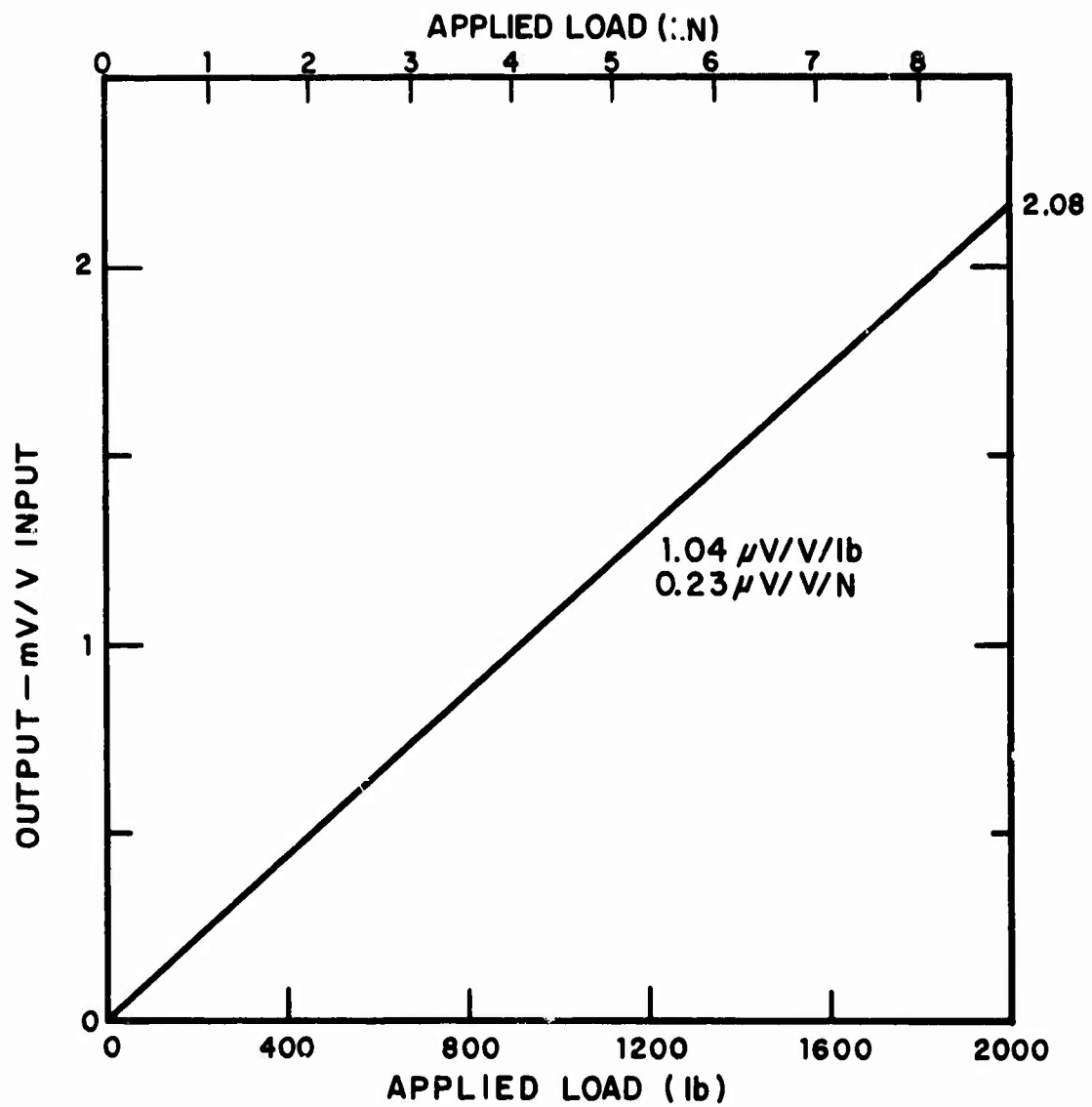

FIG. 10. VERTICAL ELEMENT CALIBRATION

The curve is linear with a sensitivity of $.23 \mu\text{V/V/N}$ ($1.04 \mu\text{V/V/lb}$). During calibration of the vertical element, the maximum output from channel H_{x1} , H_{x2} was less than $1 \mu\text{V/V}$ and the maximum output from channel H_{y1} , H_{y2} was less than $3 \mu\text{V/V}$. Raw calibration data is presented as an appendix.

Figure 11 shows the force balance in position for calibrating one of the horizontal elements. The calibration for horizontal elements H_{x1} , H_{x2} is shown in Fig. 12. The curve is again linear with a sensitivity of $.12 \mu\text{V/V/N}$ ($0.54 \mu\text{V/V/lb}$). The maximum output from channel H_{y1} , H_{y2} was less than $2 \mu\text{V/V}$ and the maximum output from the vertical channel less than $6 \mu\text{V/V}$. The calibration for horizontal elements H_{y1} , H_{y2} is shown in Fig. 13. The output is also linear with a sensitivity of $.09 \mu\text{V/V/N}$ ($0.41 \mu\text{V/V/lb}$). The maximum output for channel H_{x1} , H_{x2} was less than $4 \mu\text{V/V}$ and from the vertical channel less than $12 \mu\text{V/V}$. This data is summarized in Table 1.

TABLE 1. SUMMARY OF CALIBRATION DATA

Loading Direction	Sensitivity		% Crosstalk at Maximum Load		
	$\mu\text{V/V/N}$	$\mu\text{V/V/lb}$	Vert.	H_{x1} , H_{x2}	H_{y1} , H_{y2}
Vert. (z)	.23	1.04	-	$\leq .1$	$\leq .4$
H_{x1} , H_{x2}	.12	0.54	$\leq .3$	-	$\leq .2$
H_{y1} , H_{y2}	.09	0.41	$\leq .6$	$\leq .4$	-

Note that the sensitivity of the vertical element is approximately twice the sensitivity of the horizontal elements.

6.2 Drift Amplitude

The balance was powered for 96 hr while under no-load conditions. Zero shift during this test was observed to be less than $5 \mu\text{V}$ in all channels. Zero shift may be expected to be minimal, since a 2 V power supply was used and, therefore, heating of the strain gauge was minimal. This

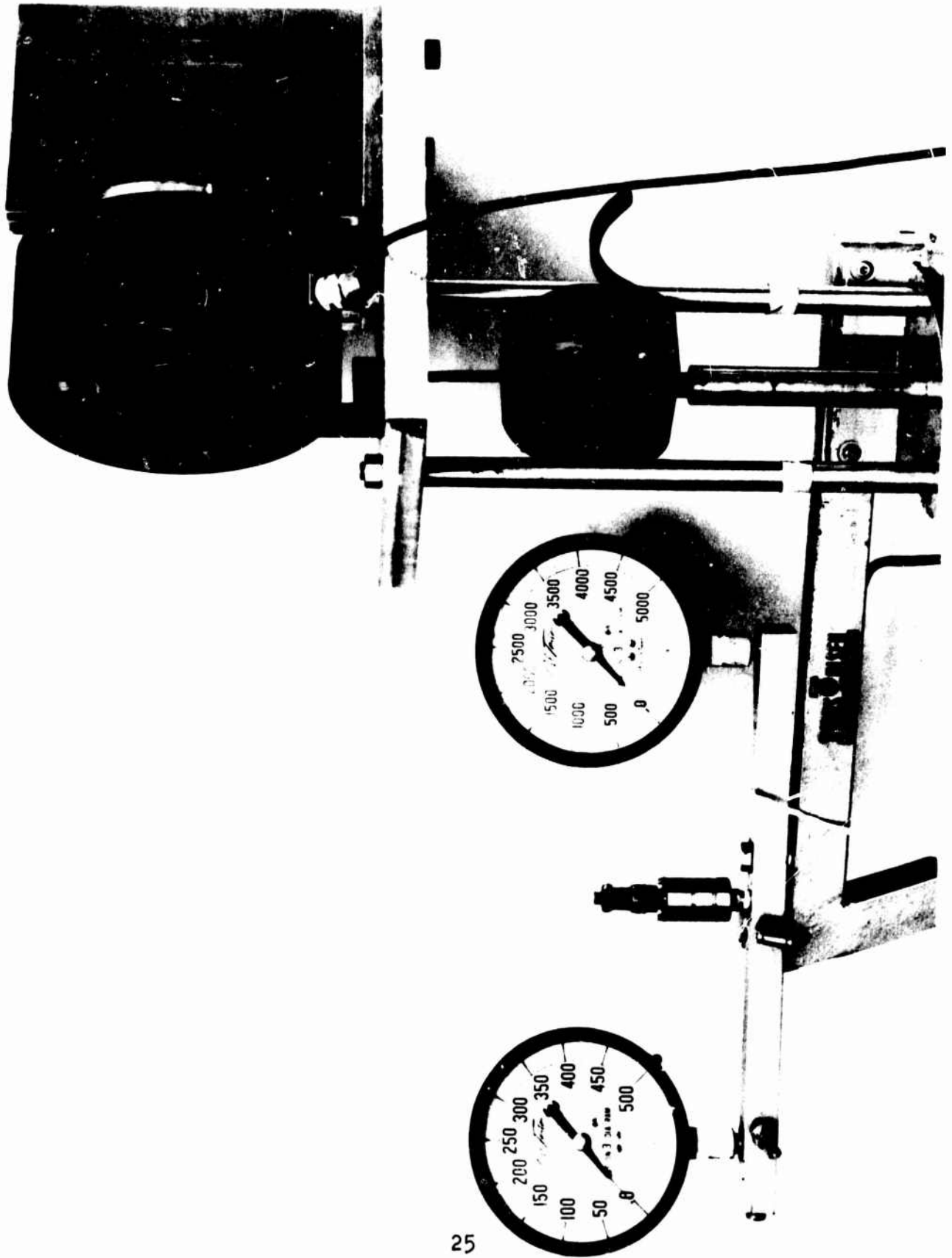

FIG. 11. CALIBRATION OF HORIZONTAL ELEMENTS

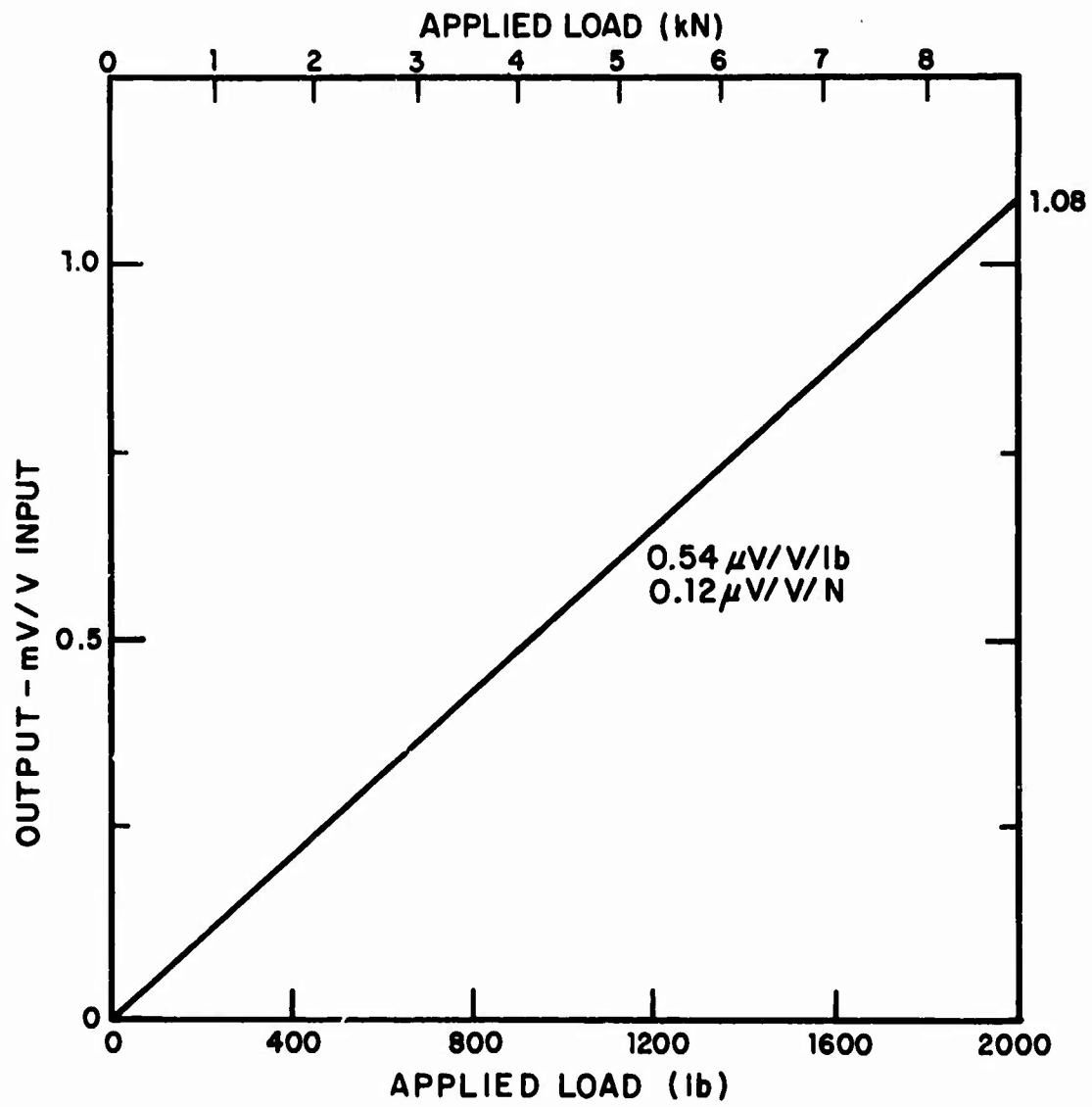

FIG. 12. HORIZONTAL (H_{x1} , H_{x2}) ELEMENT CALIBRATION

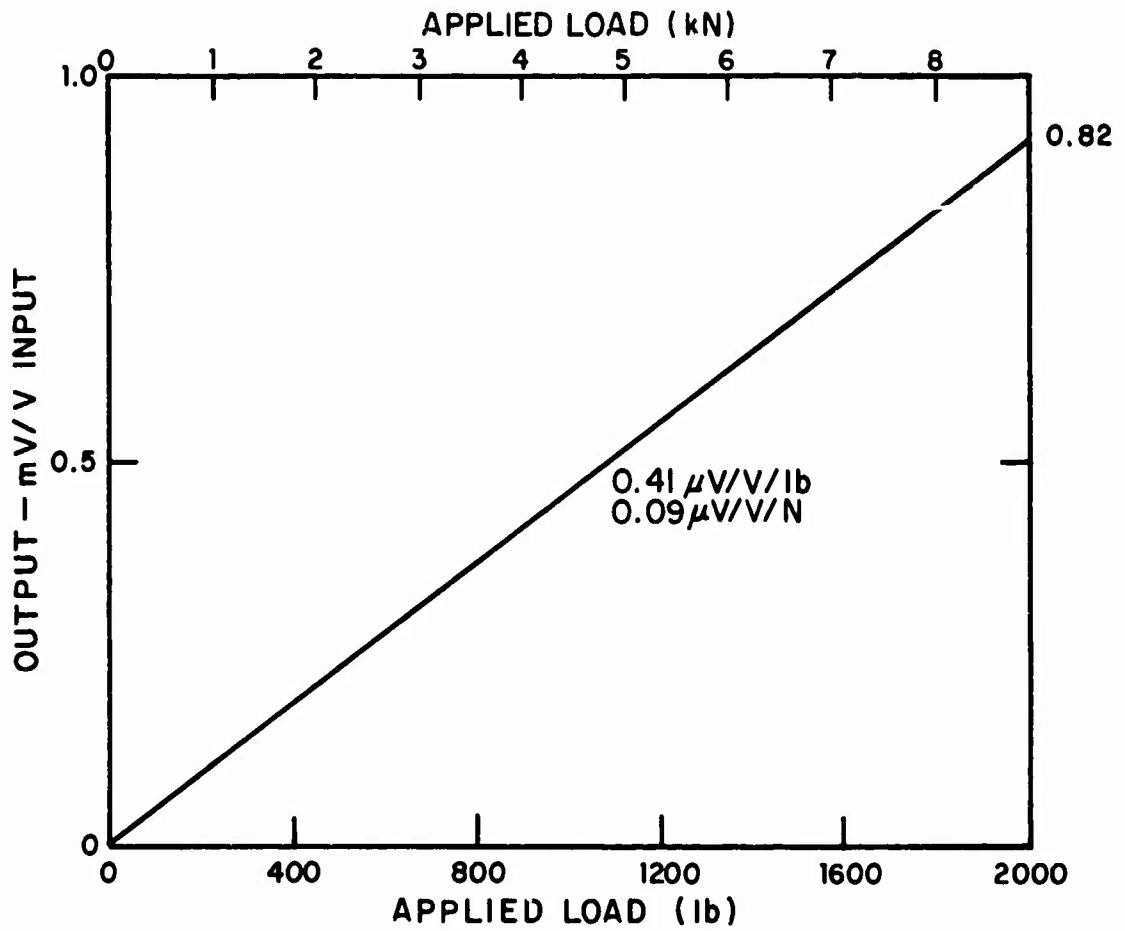

FIG. 13. HORIZONTAL (H_{y1} , H_{y2}) ELEMENT CALIBRATION

is a difficult measurement to make in that zero shift is measured not only in the balance but also in all parts of the instrumentation chain, i.e., power supply, read out, balancing networks, and amplifiers. It is, therefore, important to use an extremely stable instrumentation chain when making this measurement.

6.3 Cyclic Loadings

The balance was cyclically loaded from 0 - 8.96 kN (2000 lb) and changes in zero and peak output were noted. Changes in zero reading were less than 1 $\mu\text{V}/\text{V}$ in all channels. Changes in peak reading were more difficult to measure owing to difficulties in controlling the 8.96 kN (2000 lb) load on the "Cal Tester". Differences in peak output were less than 1%; however, we do not know whether to attribute them to changes in gauge output or to variations in the loading. The use of a more accurate tensile tester should remedy this problem.

6.4 Temperature Stability

The balance was subjected to a 28° K (50° F) rise in temperature, from 294° K to 322° K (70° F to 120° F), by placing it in a controlled oven. This sudden temperature shift is obviously much more severe than the balance will undergo when in use. Maximum output from any channel during this test was 3 $\mu\text{V}/\text{V}$.

6.5 Stability Under Wind Loadings

The unloaded balance was subjected to wind loadings at velocities of 15.7, 31.3, and 49.2 m/s (35, 70, and 110 mph) for 5 min at each velocity. Maximum output from any channel at the highest velocity was 1 $\mu\text{V}/\text{V}$.

SUMMARY

A three-directional load transducer has been developed to measure loads in tent tie downs. The transducer is equipped with a swivel at the load attachment point which will rotate to align itself with the instantaneous direction of a tie down cable. The transducer has a load range of 8.96 kN (2000 lb) in each of its measuring directions. Crosstalk between channels is less than 1% of full scale. In addition, the output is very insensitive to temperature changes and to wind loadings.

APPENDIX: RAW CALIBRATION DATA

Figures A.1, A.2, and A.3 contain the raw calibration data for the three-directional load transducer when powered by 2 V dc. The three curves of Fig. A.1 represent the output of the x-axis measuring element when the transducer is loaded to 8.96 kN (2000 lb) along the z, y, and x axes, respectively. Figures A.2 and A.3 are similar plots for the y and z measuring elements. The ordinate of the curves is the output of the transducer and the abscissa is the output from a load transducer which monitors the testing machine. The plots, therefore, represent a continuous loading function rather than one performed at discrete loading intervals. The sensitivities of the measuring elements in their measurement direction are indicated on the plots. A line has been drawn on the output curves of the channels which were not loaded. This line represents 1% crosstalk.

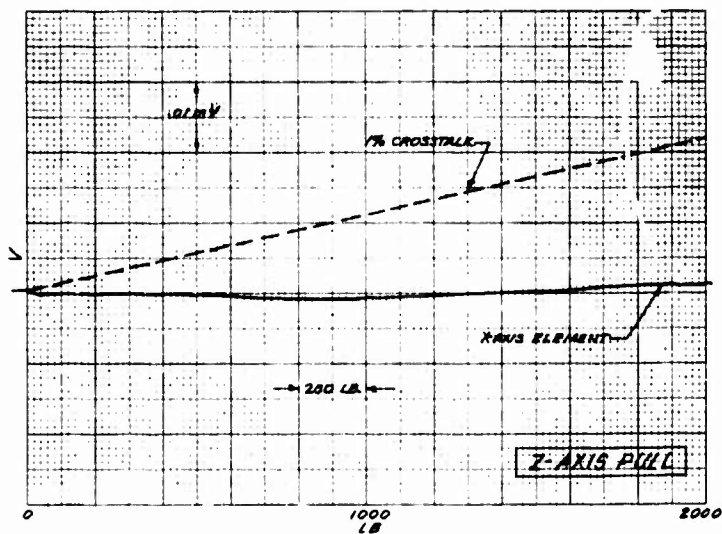

(a) z-Axis Loading

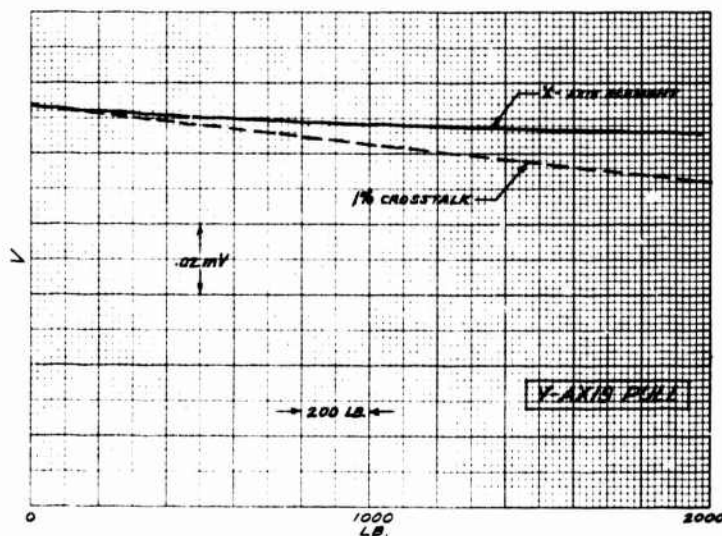

(b) y-Axis Loading

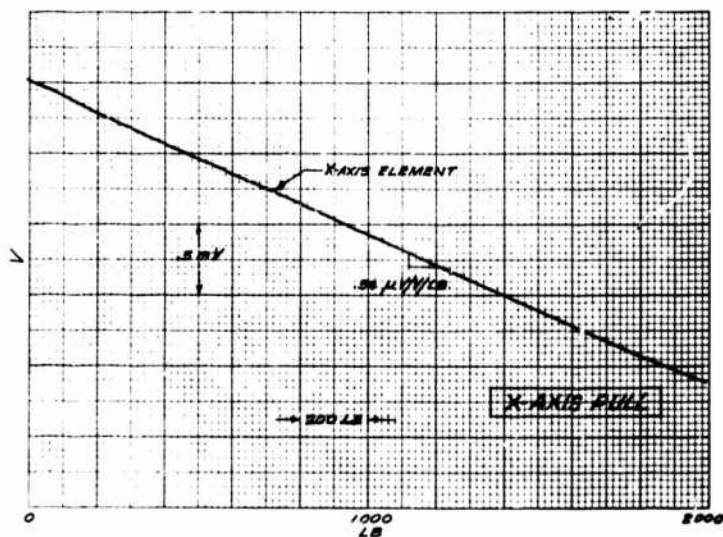

(c) x-Axis Loading

FIG. A.1. OUTPUT OF X-AXIS ELEMENT RESULTING FROM LOAD APPLIED IN THE Z, Y, AND X DIRECTIONS.

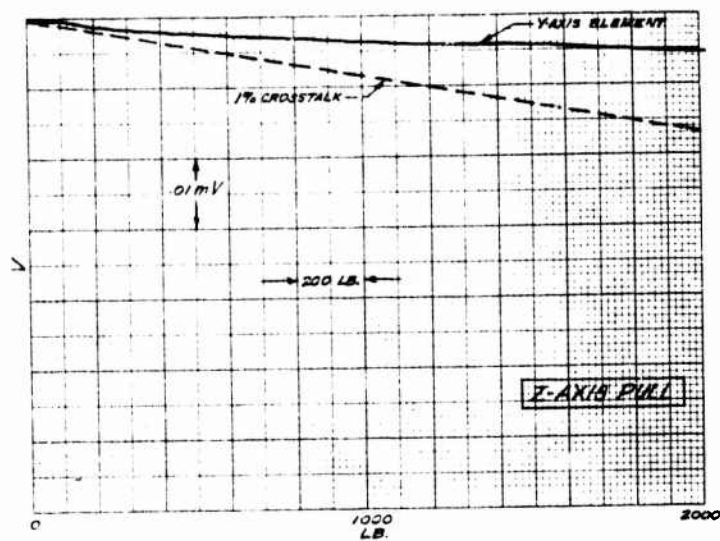

(a) z-Axis Loading

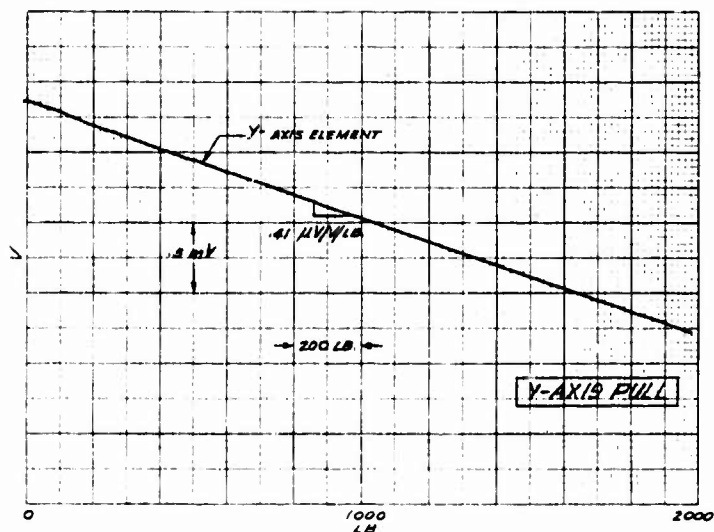

(b) y-Axis Loading

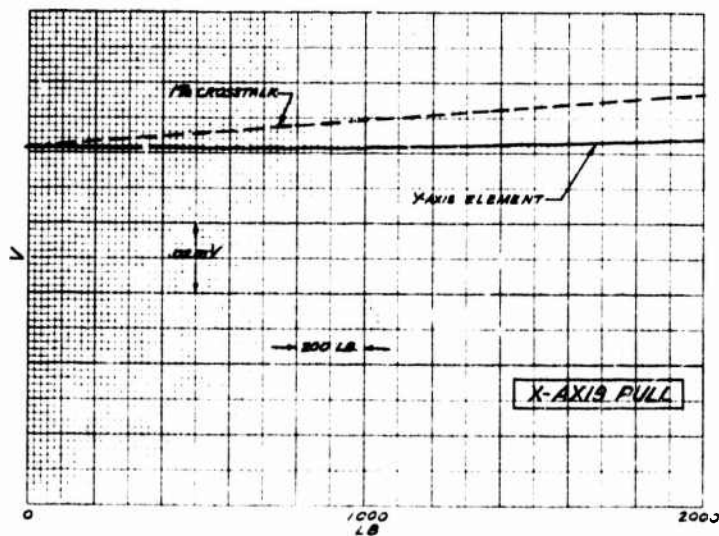

(c) x-Axis Loading

FIG. A.2. OUTPUT OF Y-AXIS ELEMENT RESULTING FROM LOAD APPLIED IN THE Z, Y, AND X DIRECTIONS 32

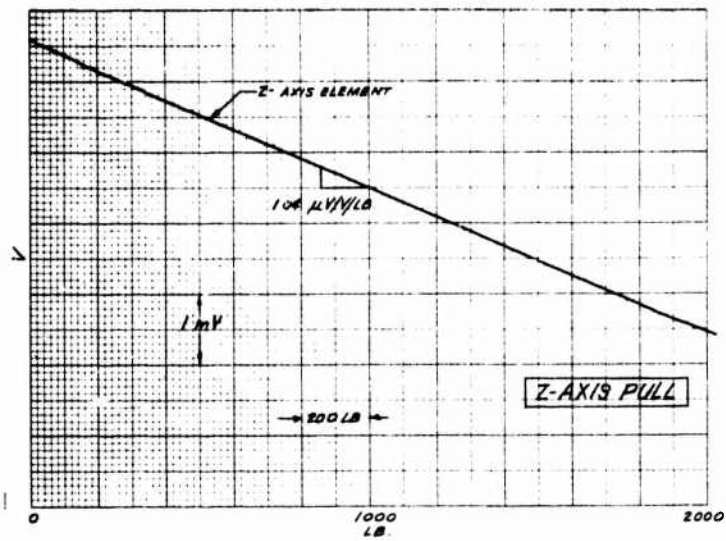

(a) z-Axis Loading

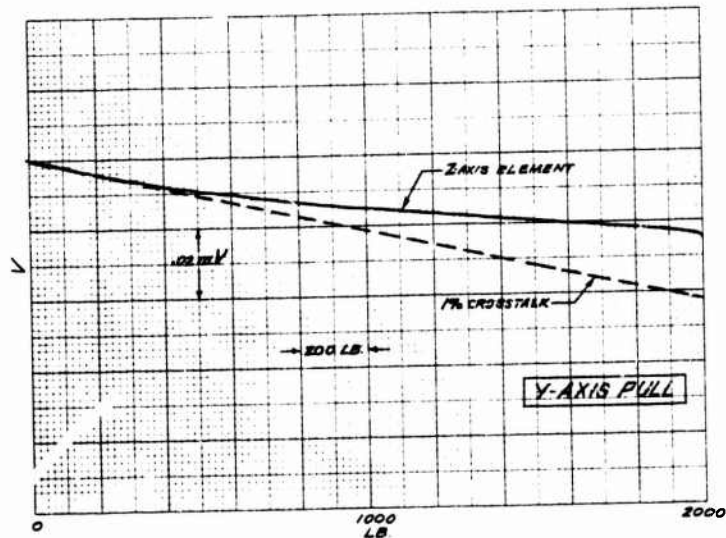

(b) y-Axis Loading

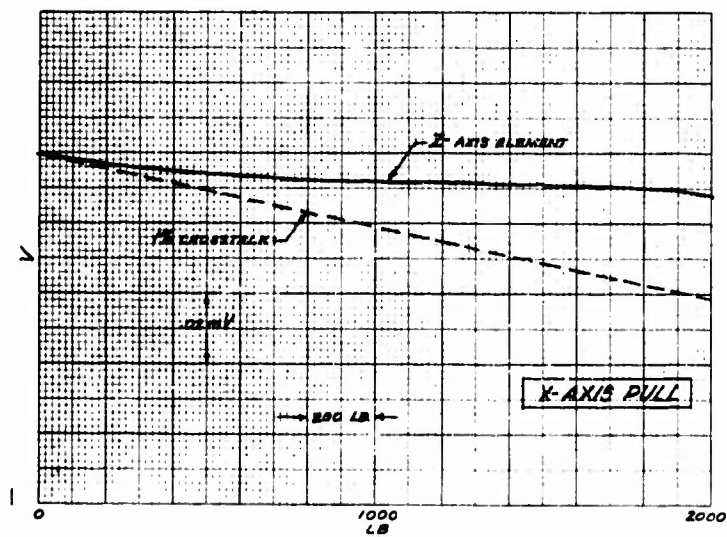

(c) x-Axis Loading

FIG. A.3. OUTPUT OF Z AXIS ELEMENT RESULTING FROM LOAD APPLIED IN THE Z, Y, AND X DIRECTIONS