

AD-778 229

DEVELOPMENT OF CLASSIFICATION SCALE
FOR CHARACTERIZING BILGE WATERS
USED IN EVALUATING OIL REMOVAL
TECHNIQUES

F. Budininkas, et al

General American Transportation Corporation

Prepared for:

Coast Guard

January 1974

DISTRIBUTED BY:

NTIS

National Technical Information Service
U. S. DEPARTMENT OF COMMERCE
5285 Port Royal Road, Springfield Va 22151

1. Report No. CG-D-75-74		2. Government Accession No.		3. Recipient's Catalog No. AD-778 929	
4. Title and Subtitle Development of a Classification Scale for Characterizing Bilgewaters Used in Evaluating Oil Removal Techniques				5. Report Date January 1974	
7. Author/s: P. Budininkas G. A. Remus				6. Performing Organization Code	
9. Performing Organization Name and Address General American Research Division General American Transportation Corporation Niles, Illinois				8. Performing Organization Report No.	
12. Sponsoring Agency Name and Address U. S. Coast Guard, G-DET-1 Office of Research & Development Washington D. C. 20590				10. Work Unit No. (TRAIS) 744305.3/1	
				11. Contract or Grant No. DOT-CG-32,521-A	
				13. Type of Report and Period Covered FINAL	
				14. Sponsoring Agency Code	
15. Supplementary Notes					
16. Abstract A method was developed for empirically classifying bilgewaters by observing the rate of oil separation from water-oil emulsions. A manually operated, compact demulsification measurement instrument for monitoring oil separation from emulsions containing oil concentrations in the 0.05% to 0.15% range, considered typical for bilgewaters, was developed and tested. The rate of demulsification is followed by reading the volume of oil separated from the test emulsion directly and visually in the instrument. The demulsification behavior of artificial bilgewater emulsions was determined using the demulsification measurement instrument. The emulsions were prepared from oils considered representative of those in use on marine vessels, namely diesel fuel, hydraulic, and lubricating and detergent-lubricating oils, mixed with either deionized, fresh or saline waters. These measurements resulted in a series of curves showing the amount of oil separated vs. time, with a separate and distinctive curve for each of the emulsions tested. The series of experimentally observed demulsification curves for each of the water-oil emulsions tested established a classification scale showing relative oil separation behavior. This classification scale, in conjunction with tests obtained with the demulsification measurement instrument, can be applied to: (a) Characterizing actual bilgewaters according to their demulsification behavior, and (b) Preparing artificial bilgewaters with known properties and separation characteristics.					
17. Key Words Artificial Bilgewaters, Bilgewater, Characterizing Bilgewater, Demulsification, Emulsification, Emulsions, Oil-Water Emulsions				18. Distribution Statement Document is available to the public through the National Technical Information Service, Springfield, VA 22151	
19. Security Classif. (of this report) Unclassified		20. Security Classif. (of this page) Unclassified		21. No. of Pages 66	22. Price \$ 3.75

ABSTRACT

A method was developed for empirically classifying bilgewaters by observing the rate of oil separation from water-oil emulsions. A manually operated, compact demulsification measurement instrument for monitoring oil separation from emulsions containing oil concentrations in the 0.05% to 0.15% range, considered typical for bilgewaters, was developed and tested. The rate of demulsification is followed by reading the volume of oil separated from the test emulsion directly and visually in the instrument.

The demulsification behavior of artificial bilgewater emulsions was determined using the demulsification measurement instrument. The emulsions were prepared from oils considered representative of those in use on marine vessels, namely diesel fuel, hydraulic, and lubricating and detergent-lubricating oils, mixed with either deionized, fresh or saline waters. These measurements resulted in a series of curves showing the amount of oil separated vs. time, with a separate and distinctive curve for each of the emulsions tested.

The series of experimentally observed demulsification curves for each of the water-oil emulsions tested established a classification scale showing relative oil separation behavior. This classification scale, in conjunction with tests obtained with the demulsification measurement instrument, can be applied to:

- (a) Characterizing actual bilgewaters according to their demulsification behavior, and
- (b) Preparing artificial bilgewaters with known properties and separation characteristics.

Preceding page blank

GENERAL AMERICAN RESEARCH DIVISION

TABLE OF CONTENTS

<u>Section</u>	<u>Page</u>
Abstract	iii
List of Figures	vi
List of Tables	vii
INTRODUCTION	1
DETERMINATION OF PARAMETERS	3
Literature Search and Study	3
Experimental Determination of Parameters	4
Experimental Apparatus	4
Test Procedure	6
Test Variables	6
Results with ASTM Procedure	8
DEVELOPMENT OF DEMULSIFICATION MEASUREMENT UNIT	19
Demulsification Measurement Instrument	19
Instrument Concept and Design	19
Measuring Instrument Description	21
Emulsion Mixer Description	25
Demulsification Measurement Procedures	27
Laboratory Test Procedure	27
Field Test Procedure	29
DEMULSIFICATION CLASSIFICATION SCALE	33
Demulsification Tests	33
Oil Types	33
Water Types	35
Experimental Results	35

TABLE OF CONTENTS
(Continued)

<u>Section</u>	<u>Page</u>
DEMULSIFICATION CLASSIFICATION SCALE (Cont'd)	
Classification Scale	51
Interpretation of Classification Scale	51
Application of Classification Scale to Bilgewaters	53
Application for the Preparation of Artificial Bilgewaters	54
CONCLUSIONS AND RECOMMENDATIONS	57
Conclusions	57
Recommendations	58

LIST OF FIGURES

<u>Figure No.</u>		<u>Page</u>
1.	ASTM Method D 14D1-67 Emulsification Apparatus	5
2.	Typical Demulsification Curves	9
3.	Dependence of Complete Separation Time on Water- Dil Ratio	10
4.	Influence of Temperature on Demulsification	12
5.	Influence of Paddle Speed on Demulsification	13
6.	Influence of Stirring Time on Demulsification	14
7.	Influence of Water pH on Demulsification	15
8.	Influence of Water Salinity on Demulsification	16
9.	Test Apparatus for Characterizing Bilgewaters	22
10.	Measuring Stem	23
11.	Driving Mechanism	24
12.	Details of Stirring Paddle and Dispersion Cup	26
13.	Reproducibility of Measurements	30
14.	Demulsification of DTE Heavy Medium Oil	42
15.	Demulsification of Mobilgard 445 Dil	43
16.	Demulsification of Rubrex 200 Oil	44
17.	Demulsification of Diesel Fuel Dil	45
18.	Demulsification from Mixtures Containing 0.15% Oil	47
19.	Demulsification from Mixtures Containing 0.10% Oil in Freshwater	48
20.	Demulsification from Mixtures Containing 0.10% Dil in Saltwater	49
21.	Demulsification from Mixtures Containing 0.05% Oil	50
22.	Oil Demulsification Classification Scale	52

LIST OF TABLES

<u>Table No.</u>		<u>Page</u>
1.	Variables Used with ASTM D 1401-67 Procedure	7
2.	Oils Used for Demulsification Tests	34
3.	Demulsification of DTE Heavy Medium Oil	36
4.	Demulsification of Mobilgard 445 Oil	37
5.	Demulsification of Rubrex 200 Oil	38
6.	Demulsification of Diesel Fuel Oil	39
7.	Demulsification of Oils in Saltwater	40
8.	Legend for Demulsification Figures	41

INTRODUCTION

Present water pollution regulations require that marine vessel bilgewater be processed to reduce its oil content before discharge overboard. Various oil removal systems have been or are being developed to achieve the high efficiency of oil removal required. Since the oil removal capability of any system will be related to the properties of the bilgewater emulsion, a meaningful comparison of the overall performance of various oil removal systems necessitates evaluation under identical operating conditions, and with adequately characterized bilgewaters of known composition and behavior.

The properties and behavior of emulsions typical of bilgewaters are determined by a variety of parameters. Characterization of bilgewater by measuring the many parameters involved is inconvenient since complex and elaborate analyses with sophisticated instrumentation are generally required. Thus, the need existed for development of a relatively simple and convenient technique for characterizing bilgewaters with respect to their behavior in oil separating systems.

Since a variety of oil removal systems are contemplated for bilgewater treatment, the need existed to provide a means for preparing artificial bilgewater to be used as a standard means of testing oil-water separators. These artificial emulsions would be representative of actual bilgewaters, and suitable for use in evaluating the performance and efficiency of various oil-water separation systems.

To fulfill these needs, a program was initiated to develop a system that could generally indicate the oil separation behavior of bilgewaters, without elaborate equipment or measurement techniques. The basic approach employed was to reproducibly generate an oil-water emulsion of known composition and history and obtain its oil separation characteristics (i.e., its demulsification behavior) by visual observation and direct measurement of the amount of oil separated over specific time intervals.

An instrument to monitor oil separation from emulsions was conceived, fabricated, and tested. Four types of oil and three types of water were used to form a series of artificial bilgewater emulsions. Oil concentrations in the 0.05% to 0.15% range, considered typical for actual bilgewaters, were studied. The oils used were a diesel fuel, hydraulic oil, and two lubricant oils; the waters used were tapwater, fresh lakewater, and a 3% saline solution.

The oil and water mixtures were emulsified in accordance with a procedure based on a modification of ASTM Designation D 1401-67, "Standard Method of Tests for Emulsion Characteristics of Petroleum Oils and Synthetic Fluids". The mixer assembly used was a modification of the mixer used in ASTM Designation D 422-63. Specific mixing speeds and mixing duration times were determined for preparing various emulsions considered appropriate to developing a bilgewater classification scale.

The demulsification measurement instrument developed for observing oil separation is a prototype laboratory model. The system is compact, weighs approximately 6.8 kg, and is easily carried. The emulsion mixer is designed to be operated by one man, and is electrically powered. No special sensor devices are required. The amount of oil separated from the test emulsion is read directly by the instrument.

The demulsification behavior of the prepared artificial bilgewater emulsions was translated into a series of curves showing amount of oil separated vs. time. This series of curves on a single chart defines the bilgewater classification scale. The classification scale exhibits a sufficiently separate and distinctive curve for each of the emulsions tested, and provides a basis for correlating probable oil separation behavior in an oil-water separation system.

DETERMINATION OF PARAMETERS

This section describes preliminary investigations of the parameters effecting the characteristics and emulsification/demulsification behavior of bilgewaters. The initial task consisted of a brief literature search and study, followed by laboratory demulsification experiments.

Literature Search and Study

A limited literature search was performed to establish the extent of available information characterizing bilgewaters, such as:

- (1) Typical bilgewater concentrations
- (2) Typical oils present in bilges and their ratios
- (3) Emulsification behavior of typical bilgewater oils.

The literature search was confined to the examination of the last five years of Chemical Abstracts, U.S. Government Research and Development Reports, and Government Reports Index, ending with June 1973 issues. Since pollution of water by oils was rarely mentioned in literature older than about two years, the examination of earlier abstracts was considered counterproductive.

The following specific headings were examined:

- | | |
|---------------------|-------------------------------|
| (a) Bilgewater | (f) Oil in Water |
| (b) Demulsification | (g) Oil Separation from Water |
| (c) Emulsification | (h) Oily Wastes |
| (d) Emulsions | (i) Water Pollution |
| (e) Oil Spills | |

Also, a report bibliography on bilgewater and its composition was obtained from the Defense Documentation Center.

Unfortunately, neither the abstract search nor DDC bibliography report produced meaningful articles specifically and directly applicable to bilgewater characterization and behavior. In fact, pollution of waters by oil was rarely mentioned in literature older than about two years, although more activity is noticeable in very recent literature.

The general literature indicated that the following parameters influence the formation and stability of oil/water emulsions:

- (1) Oil type and concentration
- (2) Water type (salinity, pH)
- (3) Temperature
- (4) Emulsification (force and length of agitation).

Experimental Determination of Parameters

Experimental determination of the influence of parameters on the demulsification behavior of oil/water mixtures was determined using the test equipment and testing procedures described in the ASTM Designation D 1401-67, "Standard Method of Test for Emulsion Characteristics of Petroleum Oils and Synthetic Fluids". The ASTM method specifies experimental parameters to be used during testing; however, in this study experimental parameters were varied to observe their influence on the demulsification process.

Experimental Apparatus

A photograph of the test apparatus used for these tests is shown in Figure 1. A Pyrex 100-ml cylinder (28 mm ID), graduated in 1-ml divisions, is immersed in a constant temperature water bath (controlled to $\pm 0.1^\circ\text{C}$) in a fixed, reproducible position on a cylinder positioning stand. The base of the graduated cylinder sits in a 3-mm deep cut-out, large enough to accommodate the 60-mm base, and is held firmly by a spring clip near the top of the cylinder.

A stainless steel shaft with a paddle welded to it was inserted into the graduated cylinder so that the bottom edge of the paddle was 6 mm from the bottom of the cylinder. The paddle is 120 mm long, 10 mm wide, and 1.5 mm thick, and the shaft is 6 mm in diameter and 400 mm long.

The paddle assembly was rotated by a variable speed stirrer capable of producing stirring speeds in the 1200-1750 rpm range. The paddle shaft was locked into the hollow shaft of the stirrer. This design allowed for vertical movement needed in raising and lowering the paddle during testing. A retaining ring on the upper portion of the paddle shaft provided for lowering of the paddle to a reproducible height for each test.

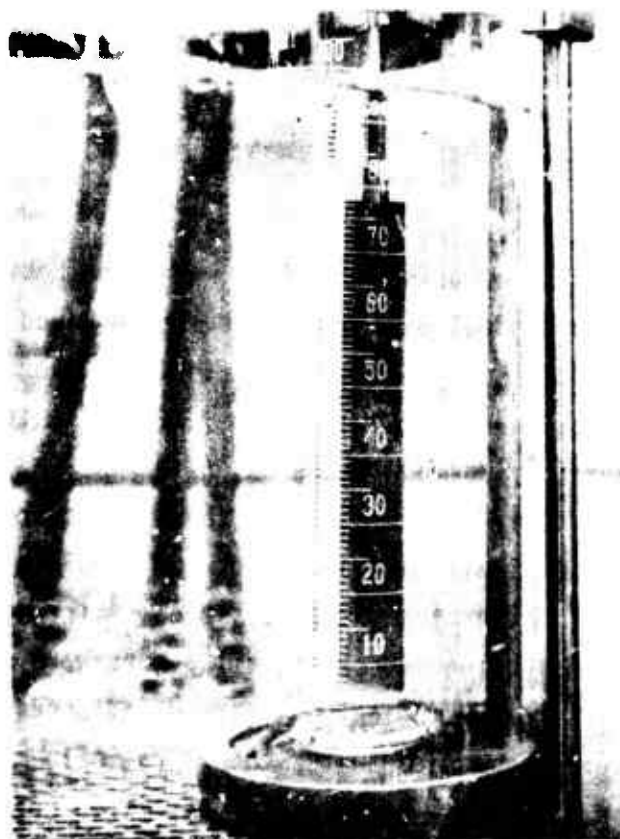
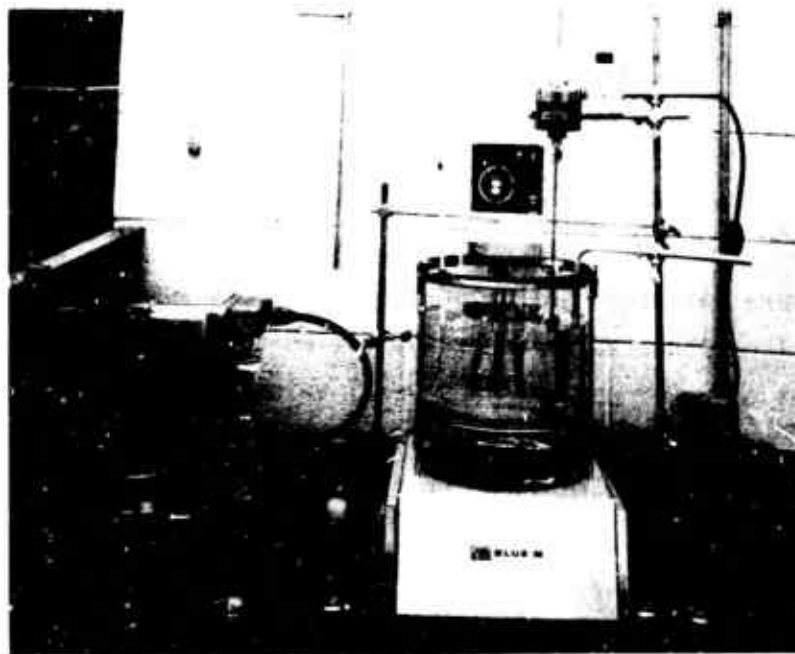

Figure 1. ASTM METHOD D 1401-67 EMULSIFICATION APPARATUS

Both the stirrer and the graduated cylinder positioning stand were secured to a common vertical aluminum rod. In this manner the relative positions of the cylinder and the paddle were maintained on a common and constant vertical axis, after the initial adjustment.

Test Procedure

Tests were performed following the procedures specified in ASTM D 1401-67. The graduated cylinder was filled to the 80-ml mark with measured volumes of water and oil in several volumetric ratios, immersed in the constant temperature bath, and allowed to equilibrate for at least 10 minutes. The cylinder was placed on the positioning stand and clipped in a fixed position. The paddle was lowered into the cylinder, and the stirrer was operated for five (5) minutes at a constant speed. After stopping, the stirring paddle was immediately lifted out of the cylinder and cleaned with a rubber policeman, allowing any oil or water clinging to it to drop back into the cylinder. The demulsification of the cylinder contents was observed for one (1) hour, taking readings every five (5) minutes and recording the volumes of oil, water, and emulsion, in that order. Before the next test, the stirrer shaft and paddle were wiped clean, first with a paper tissue moistened with a solvent, and then with a dry tissue.

Test Variables

Tests were performed using deionized water and Mobil DTE Heavy oil, which is one of the typical oils used in diesel-powered boats. For tests with different acidities, the pH of the deionized water was adjusted either with hydrochloric acid or sodium hydroxide. For salinity tests, measured weights of NaCl were dissolved in the water.

The levels of variables used during these tests are indicated in Table 1 together with their general effects on demulsification. Only one of the variables of temperature, paddle speed, stirring time, pH, and salinity was changed during each test; all others were held at selected levels. Since early tests indicated a marked influence of the water-to-oil ratio on demulsification, three water-to-oil ratio levels were tested with each of the other variables. Additional tests were performed with oil concentration in the 0.2%-1.0% range while holding the other variables constant at the medium level indicated in Table 1.

TABLE 1
 VARIABLES USED WITH ASTM D 1401-67 PROCEDURE

Variable	Variable Levels			Effect on Demulsification
	Low	Medium	High	
Water/oil ratio cc/cc	79/1	60/20	40/40	Increase in water/oil ratio accelerates separation of oil
Temperature, °C	25	54	70	A decrease in temperature increases the stability of emulsion
Paddle Speed, rpm	1300	1500	1740	Insignificant in ranges tested
Stirring time, min	2.5	5	10	Insignificant in 2.5 - 5 min range, increased emulsion stability at 10 min.
Water pH	2	5.9	11.3	Influence depends on water/oil ratio
Water salinity, % NaCl		0	3	Little influence

Experimental Results with ASTM Procedure

The demulsification of oil and water mixtures was measured by recording the change in volumes of oil, water, and remaining emulsion every five minutes after stirring stopped. Regardless of other experimental conditions which influenced the times required for a total oil-water separation, all tests with oil concentrations above 1% produced S-shaped curves of volumes vs. time for both oil and water. Typical separation curves are illustrated in Figure 2 for mixtures with oil concentrations of 50% and 33%, under standard experimental conditions. Generally, oil reached its original volume before water. At that time, there was a layer of emulsion between the oil and water; however, its disappearance did not increase the volume of oil. This apparently was because the separated oil is not completely pure, but contains some water, indicated by a cloudy appearance of the oil layer. Apparently, the transfer of small amounts of oil from the emulsion layer into the separated oil is counterbalanced by transfer of water out of the separated oil layer. Even after apparent complete separation, both oil and water layers remained unclear for long periods of time. Typically, both oil and water layers returned to their original clear appearance on standing undisturbed for eight to sixteen hours.

(a) Oil Concentration (Figure 3) - Oil concentration was found to be the most important variable influencing oil-water separation. Figure 3 presents experimentally observed times required for complete separation of oil and water layers for varied oil concentrations. The separation rate increased with decreasing initial oil concentrations in the 50% to 1% range. With decreasing oil concentrations, the stirring specified by the ASTM D 1401-67 is insufficient for complete emulsification and dispersion of the oil in water. As a result, oil which remains undispersed apparently floats to the surface immediately when stirring stops, and is the likely reason for the experimentally observed increased rate of separation.

With oil concentrations typical of bilgewaters, i.e., 1% or less, the separation of such undispersed oil occurred very rapidly, generally within 5-7 seconds after stirring stopped; the separated volume was estimated at 50%-70% of the initial oil. However, a portion of the oil was dispersed and the water phase was usually cloudy because it still contained a large number of extremely fine oil droplets, and could be classified

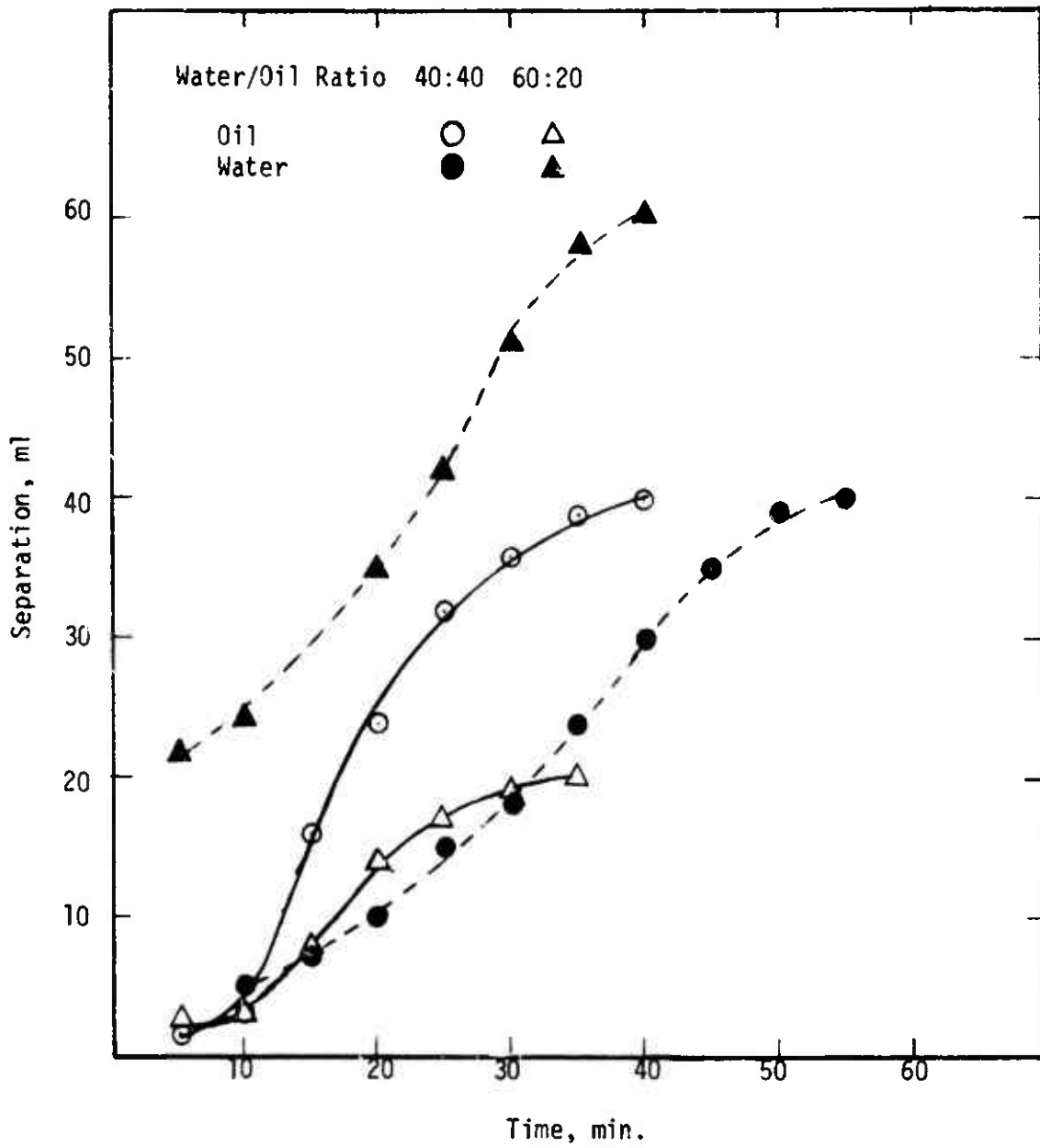

Figure 2. TYPICAL DEMULSIFICATION CURVES

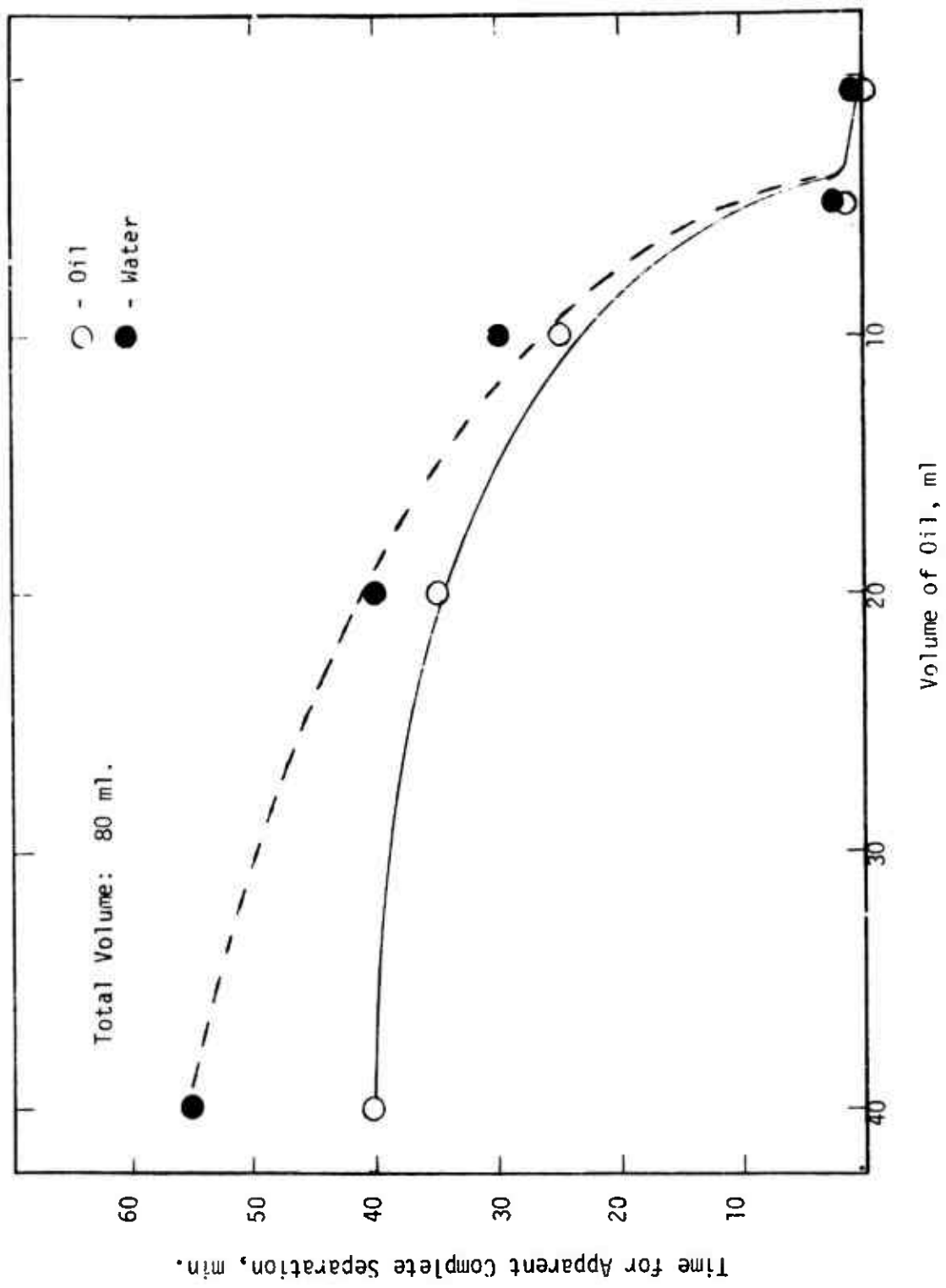

Figure 3. DEPENDENCE OF COMPLETE SEPARATION ON WATER/OIL RATIO

as a relatively stable emulsion. The dispersed oil particles remaining in water appeared to consist of two types: larger droplets which rise slowly and coalesce within several hours on the surface of water as an oily layer, and significantly smaller particles, which either coalesce only after 16 hours or not at all, visible only when illuminated by a light shining through the cylinder.

Although the larger oil particles of this microemulsion eventually coalesce, the progress of their separation is very difficult to monitor. When particles coalesce, the visible cloudiness diminishes very gradually throughout the entire cylinder without exhibiting any sharp boundaries. Therefore, the disappearance of cloudiness vs. time cannot be used in this case as an indicator for oil separation. The volume of oil eventually separating from the microemulsion is very small and cannot be employed as a means of measurement with the unmodified ASTM apparatus. However, a capillary-type oil collection column would be a feasible instrument for this purpose.

Since the oil concentrations exhibit such a pronounced effect on demulsification rate, the influence of other variables was investigated using three (3) different concentrations of oil in water (results are summarized in Figures 4 through 8). Time required for complete separation of oil and water to their original volumes was used as an indication of the influence of each variable.

(b) Temperature (Figure 4) - As expected, an increase in temperature decreased the stability of an emulsion and resulted in a shorter time required for complete separation. Emulsions prepared at 25°C with 50% and 33% oil concentrations did not separate within 60 minutes and, therefore, are not included in the graphs.

(c) Paddle Speed (Figure 5) - Within the investigated range of 1300-1740 rpm, paddle speed showed little or no influence on demulsification.

(d) Stirring Time (Figure 6) - Within 2.5 and 5 minutes, stirring time exhibited no influence. However, 10 minutes of stirring produced a significantly more stable emulsion, requiring a longer time for complete demulsification.

(e) pH (Figure 7) - The influence of pH may depend on the water-to-oil ratio. The separation time of mixtures containing 50% oil increased

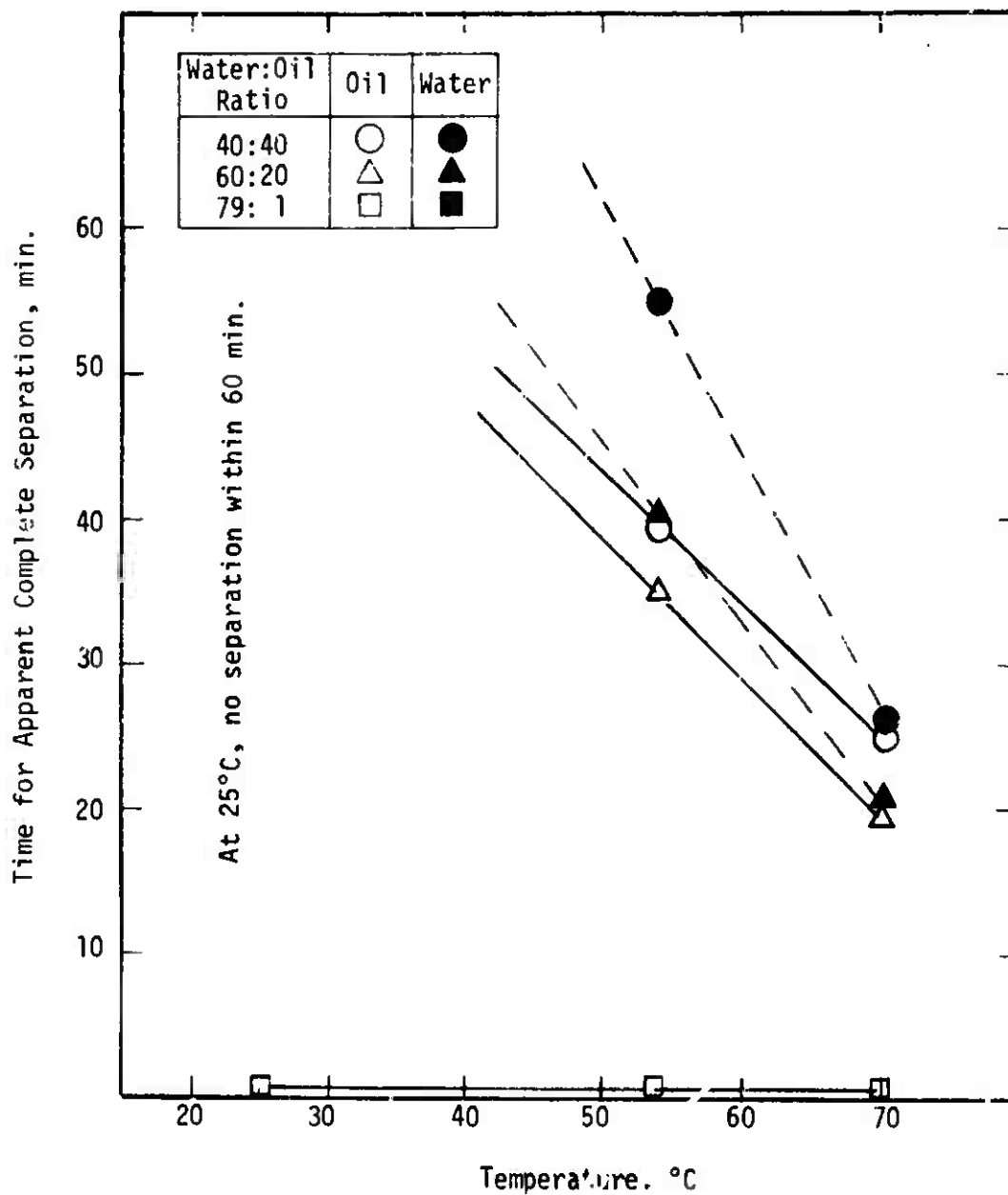

Figure 4. INFLUENCE OF TEMPERATURE ON DEMULSIFICATION

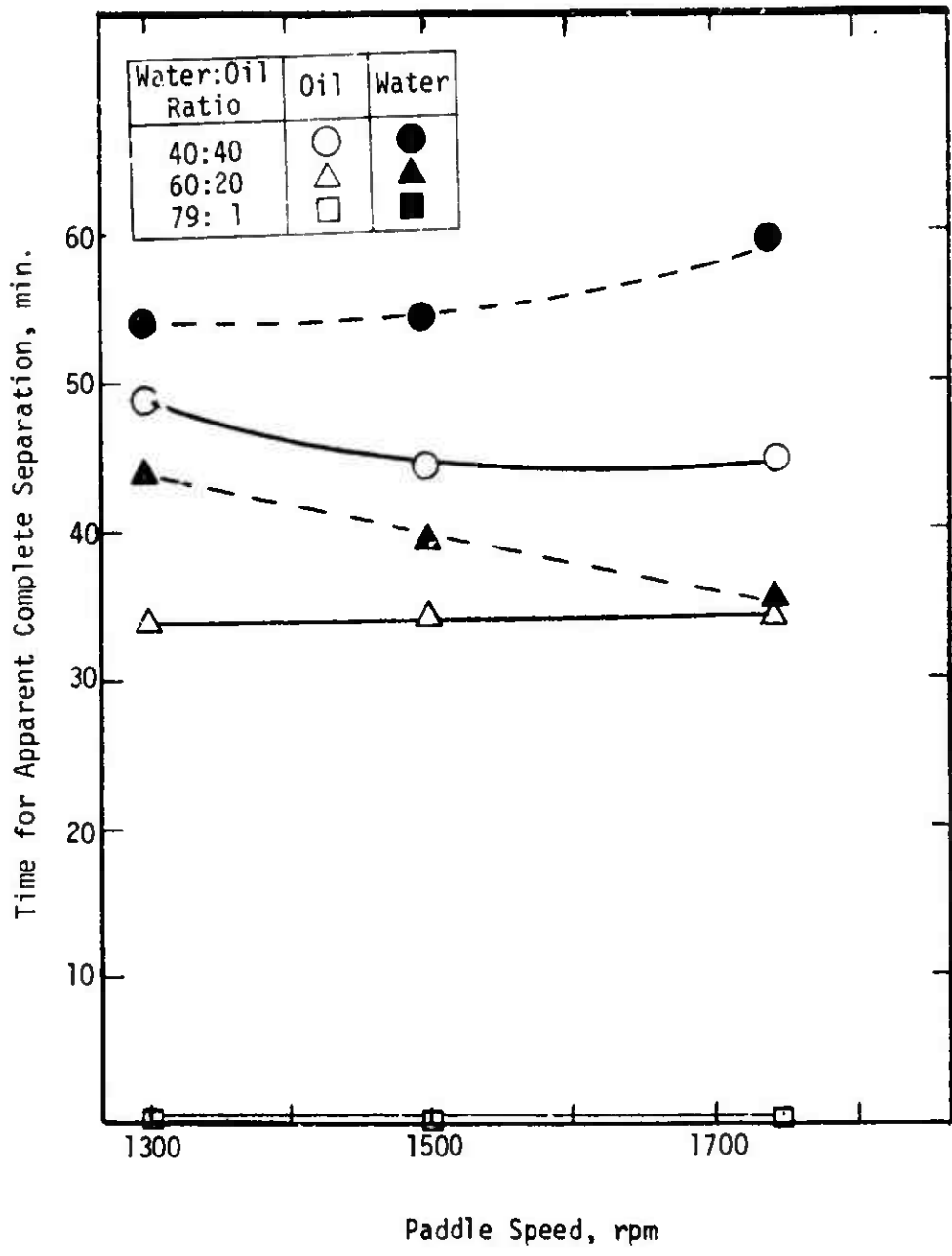

Figure 5. INFLUENCE OF PADDLE SPEED ON DEMULSIFICATION

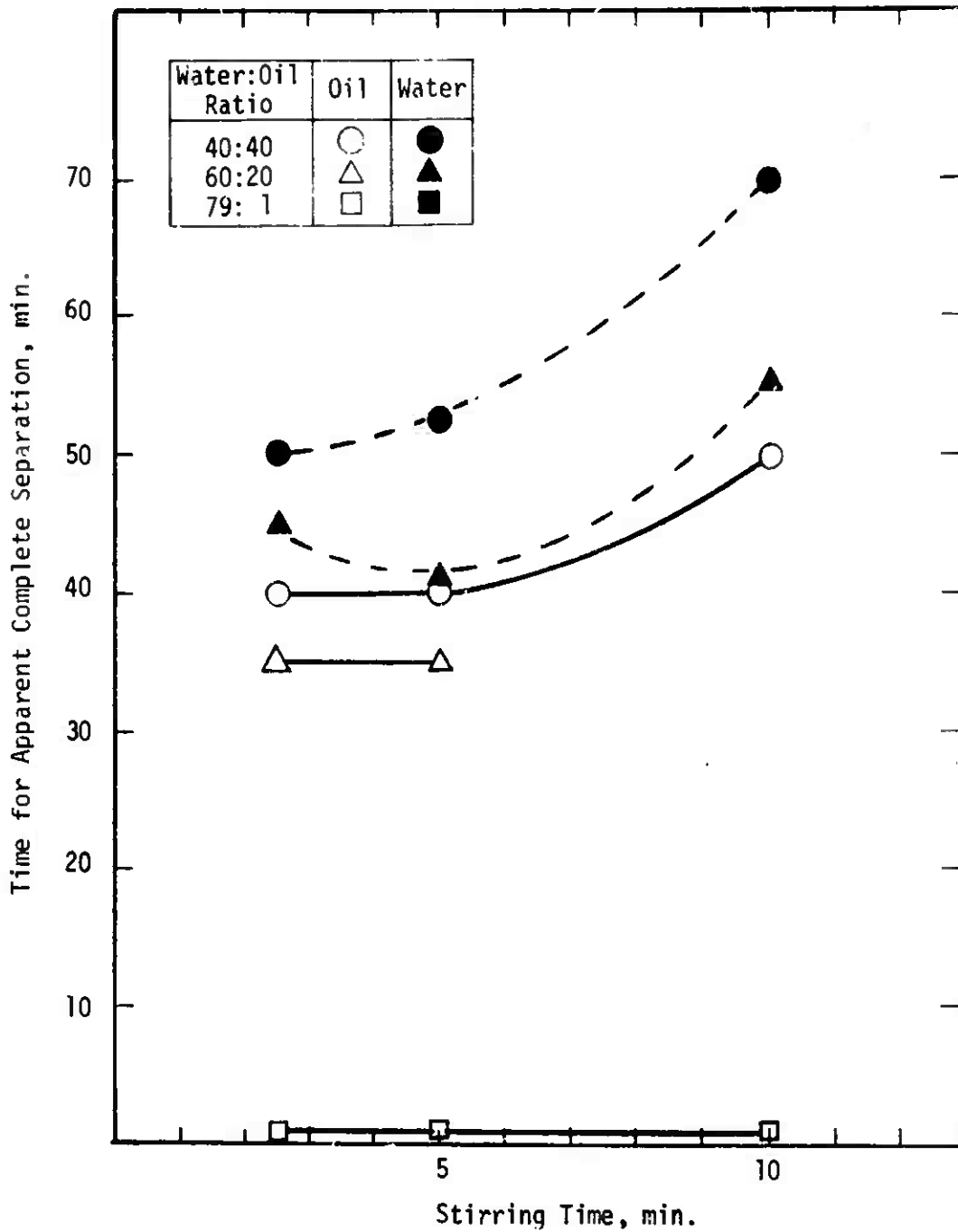

Figure 6. INFLUENCE OF STIRRING TIME ON DEMULSIFICATION

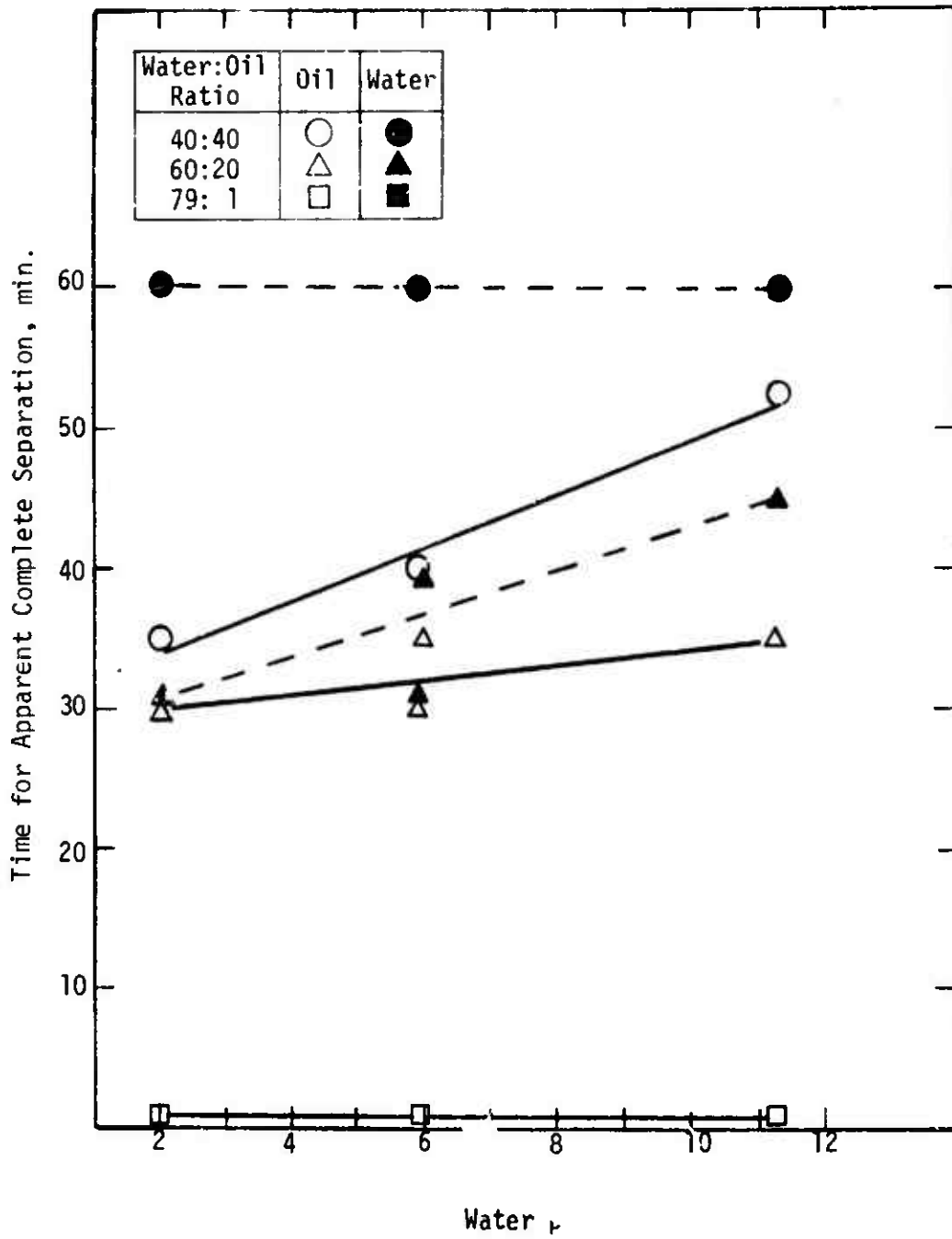

Figure 7. INFLUENCE OF WATER pH ON DEMULSIFICATION

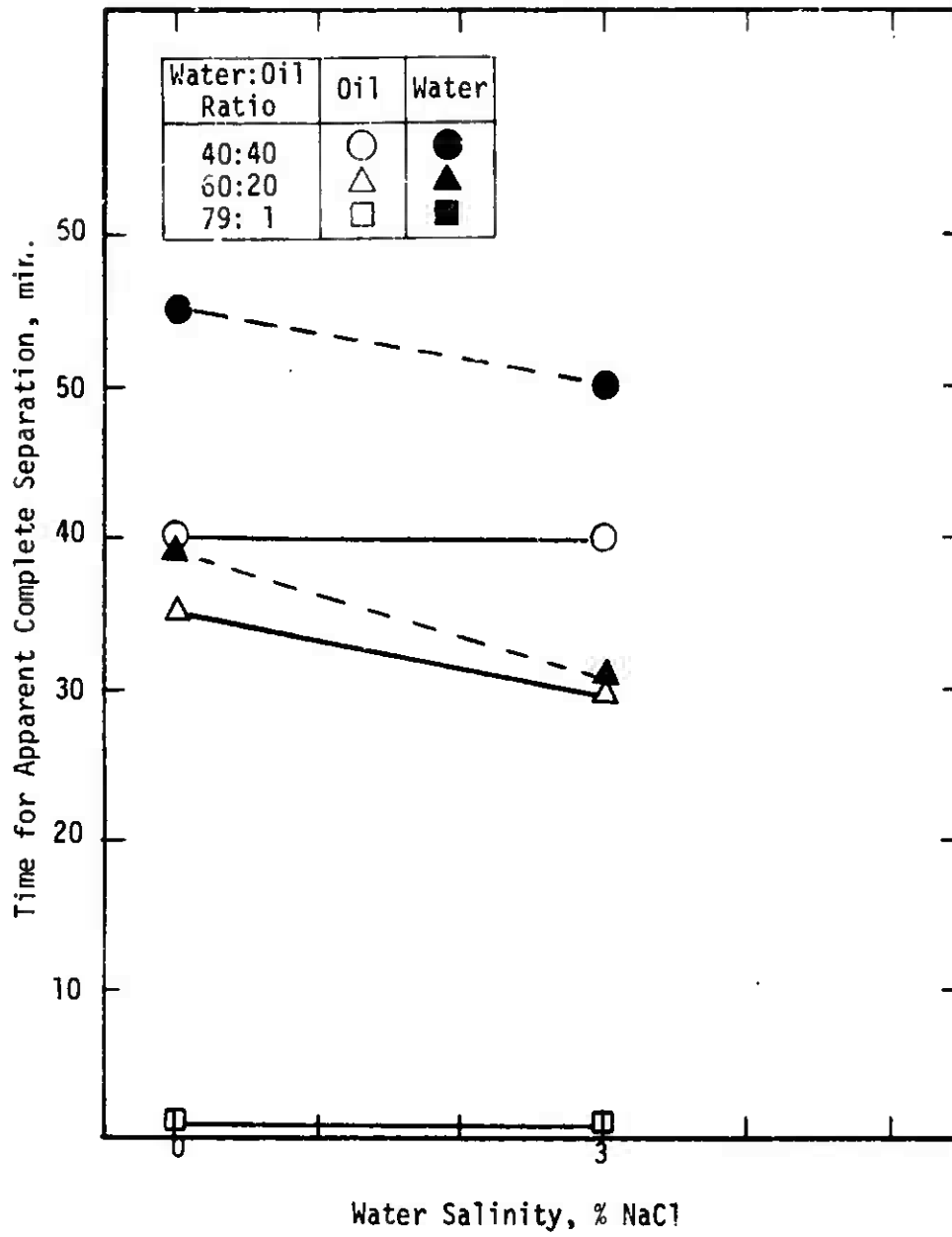

Figure 8. INFLUENCE OF WATER SALINITY ON DEMULSIFICATION

with an increase in pH, while 33% oil mixtures were influenced very little by changes in pH.

(f) Water Salinity (Figure 8) - Addition of 3% NaCl to water resulted in little or no change in oil separation time, but a somewhat decreased separation time for water.

Within experimental ranges indicated in Table 1, the separation time of oil and water using demulsification procedures described in the ASTM Designation D 1401-67, "Standard Method of Test for Emulsion Characteristics of Petroleum Oils and Synthetic Fluids", was not influenced significantly by the paddle speed, stirring time, pH, and salinity of water, and was notably decreased by an increase in temperature. Also, a decrease in oil concentration from 50% to the 1.2% level sharply decreased the time for oil separation from 40 minutes to about one minute. The ASTM D 1401-67 procedure is insufficient to produce complete dispersion and emulsification of oil present in low concentrations, resulting in a rapid separation of undispersed oil after stirring stopped. With oil concentrations applicable to bilgewaters, i.e., less than 1% oil, some 50%-70% of the oil remains undispersed and separates even more rapidly, within 5-7 seconds. Based on this behavior, the unmodified ASTM D 1401-67 procedure was found unsuitable for classifying bilgewaters according to their demulsification characteristics.

DEVELOPMENT OF DEMULSIFICATION MEASUREMENT UNIT

Preliminary demulsification tests indicated that the ASTM Designation D 1401-67 procedure is not entirely suitable for characterizing oil-water emulsions containing low oil concentrations typical of marine bilgewaters. Because of the small amounts of oil involved, the procedure was found impractical for following the extent of oil separation with time by measuring the growth of the separated oil layer when a standard 100-ml graduated cylinder was used. Visual observation of the measurement of changes in only the appearance of the emulsion, namely, its opacity, was inadequate for indicating the extent of demulsification. An additional problem was that incomplete dispersion of oil occurred for low oil concentrations when emulsification was effected by the ASTM stirring procedure. Still further, some of the oil that remained undispersed adhered either to the mixing paddle or to the cylinder walls; this behavior introduced large and indeterminate errors in establishing the true concentration of dispersed oil, and caused nonreproducibility in testing.

To overcome the above limitations, a special laboratory test instrument was conceived, constructed, and operated for observing the demulsification behavior of oil-water mixtures containing oil concentrations found in typical bilgewaters.

Demulsification Measurement Instrument

The laboratory measurement instrument for classification of bilgewaters by observation of the demulsification behavior of oil-water mixtures is shown in Figure 9. The system consists of an emulsifying mixer and a demulsification measurement assembly. The laboratory instrument is designed to show the demulsification behavior of oil-water mixtures containing low oil concentrations, normally in the 0.05% to 0.15% range.

Instrument Concept and Design

To observe the demulsification rate of mixtures containing low oil concentrations, the demulsification tube must be capable of measuring the small volumes of oil separating out above the emulsion. For example, for an emulsion containing 0.15% oil, the maximum thickness of the oil layer

Preceding page blank

that would separate out above the emulsion would be 0.15% of the height of the total liquid column. Therefore, using a column of liquid 50 cm high in the vertical demulsification tube the oil layer generated would be only 0.075 cm thick when all the oil coalesced. Observing the growth of the layer with time is not easily accomplished, since the time for demulsification ranges from two to three hours; the increase in layer thickness observed at 10 to 20 minute intervals is not readily discernible by unaided visual measurement.

To achieve adequate visual observation of the volume of oil separated, the diameter of the section of tube in which the separated oil collects was designed to be approximately 7% of the diameter of the demulsification tube. The increase in height, i.e., thickness of the separated oil layer is thus magnified by a factor of 180. The total height of the collected oil would be 180×0.075 cm, or approximately 13 cm, if all of the oil in the example separated out. In actual operation, the first 25%-30% of the dispersed oil separates out in two to three hours, so that height of the oil column separated in that time averaged 4 cm. The oil that did not separate eventually does so in the next 100-148 hours, but the resulting volume-time relationship is not conveniently useful for characterizing oil-water emulsion behavior.

Unfortunately, in initial observations using the narrow diameter measuring stem, with the emulsion-separated oil interface within the stem, a large portion of separated oil did not rise up into the stem but collected on the lower side of the shoulder in the tapered reducing section connecting the stem to the demulsification tube. When the separated oil-emulsion interface was positioned initially in the large diameter tube and raised periodically into the measuring stem to observe the change in height of the oil layer, separated oil collected on the shoulders of the tapering section. In either case the oil collecting on the tapered shoulders introduced a significant error in the true volume of separated oil.

To eliminate this error, a water-immiscible solvent, namely n-heptane, which is lighter than water, was added to and floated on the top of the emulsion, with the solvent-emulsion interface in the large diameter tube. Oil which separated entered into solution with heptane. This solvent does not readily form solvent bubbles on the glass walls of the unit. Consequently, when the solvent-emulsion interface is raised into or lowered down

from the measuring stem, no oil or solvent adheres to the shoulder of the tapered connecting section.

The increase in the volume of oil separating from the emulsion is observed by measuring the increase in volume of the added solvent. Hexane and heptane were found particularly suitable as solvents because they are immiscible in water, mix readily with oils, wet glass walls more easily than water, and the volumes of solvent and oil are additive.

Measuring Instrument Description

The demulsification assembly was shown pictorially on the left in Figure 9. It consists of the glass demulsification tube and measuring stem section, and an aluminum piston and drive unit for raising and lowering the emulsion-solvent interface into and out of the measuring stem.

The demulsification section consists of a 46-cm long, 41-mm OD, 38-mm ID Pyrex glass tube with a 9-mm diameter measuring stem connected to its tapered top end. The bottom end is slightly flared and ground flat to mate with the piston-drive section. The volume of the demulsification tube, measured from the bottom to the onset of tapered shoulders, is 500 ml. The measuring stem, extending above the demulsification tube, is a 25-cm long capillary tube with 2.5-mm bore and an expanded bulb section having an approximate volume of 1.75 ml. The volume of this expanded section is such that the initially introduced 2-ml volume of heptane solvent extends to some extent into the capillary below and above the expansion, providing an accurate reading of the solvent volume when it is initially added. The stem is shown in Figure 10.

The drive unit is attached to the flared, open end of the demulsification tube. A soft rubber gasket pressed between the housing of the driving mechanism and the ground end of the tube effects a leakproof seal.

The driving mechanism shown in Figure 11 consists of an aluminum cylinder and piston. The piston proper is 5.7 cm long, 2.38 cm in diameter, and effects up to a 25-ml displacement when driven all the way into the tube. The bottom end of the piston shaft is threaded and extends through a matching threaded opening in the bottom of the cylinder; rotating the shaft extends or retracts the piston. An "O" ring located in the upper portion of the cylinder fitting around the piston allows proper movement without leakage.

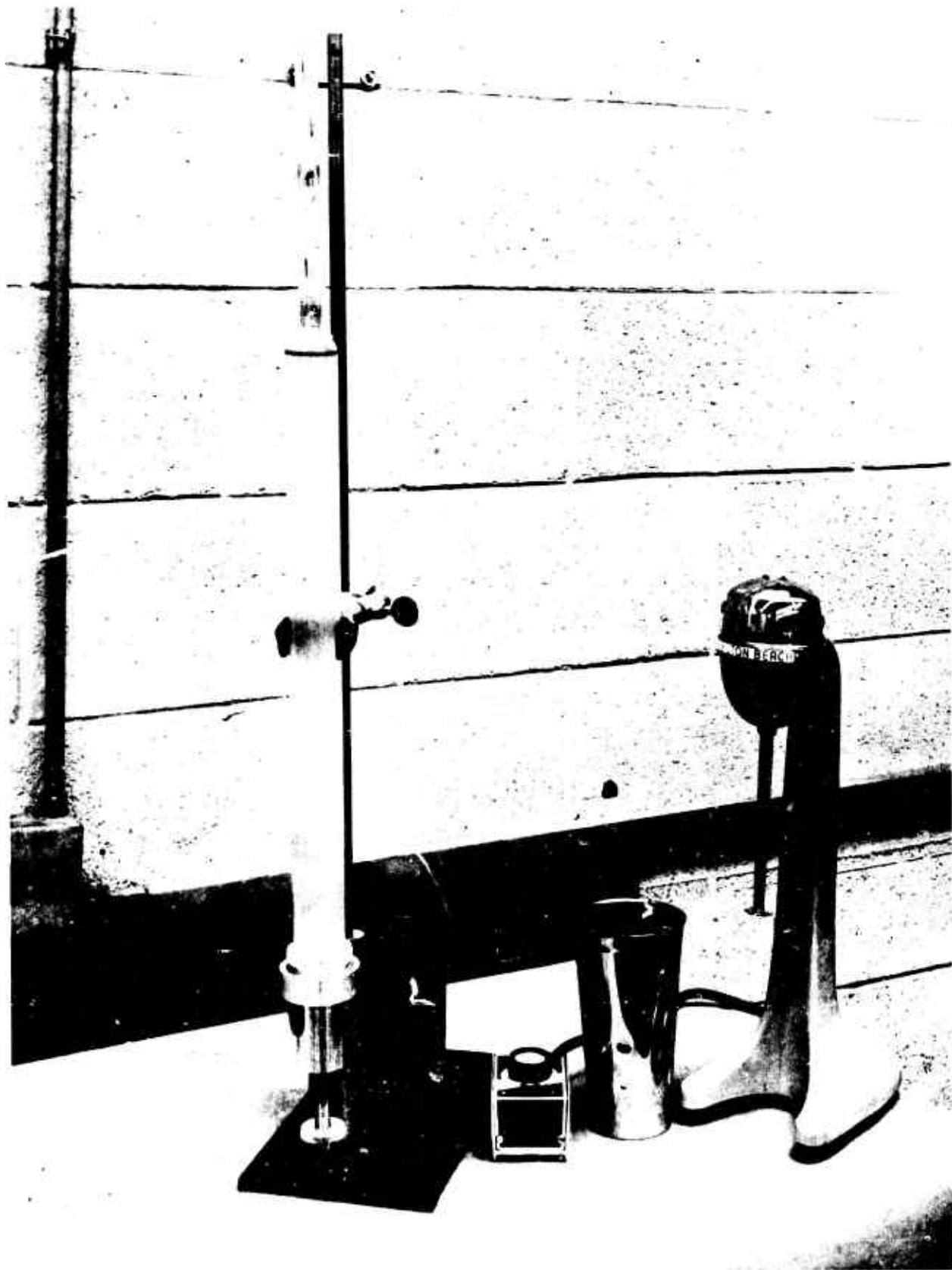

Figure 9. TEST APPARATUS FOR CHARACTERIZING BILGEWATERS



Figure 10. MEASURING STEM



Figure 11. DRIVING MECHANISM

When the piston is maintained in the retracted position, all of the emulsion and heptane layer is located entirely within the straight portion of the demulsification tube, i.e., just below the onset of the tube shoulders. When measuring the volume of separated oil, the piston is extended into the tube until all the heptane solvent, containing separated oil, is within the measuring stem. Immediately after each reading is made, the piston is retracted back to its original position, lowering the contents back completely into the demulsification tube.

Emulsion Mixer Description

As previously described, the standard emulsion generating method of ASTM D 1401-67 was found inadequate for emulsifying the low concentrations of oil typical of bilgewater. After mixing at 1500 rpm in the standard 100-ml graduated cylinder some of the oil remained undispersed and also adhered either to the paddle or to the walls of the cylinder, causing unpredictable discrepancies in the concentration of dispersed oil. An increase in the rotation speed of the paddle up to 6,000 rpm did not alleviate the problem sufficiently; speeds above 6,000 rpm were impractical because the contents splashed violently and ejected from the mixing container.

A readily available commercial mixing apparatus described by ASTM Designation D 422-63 for dispersing soils was found appropriate for forming low concentration oil-in-water emulsions. The mixing apparatus consists of an electrical motor mounted on a stand which rotates a vertical shaft equipped with a replaceable stirring paddle. A special stainless steel dispersion cup is provided to hold the sample while it is being dispersed. The unit is similar to the common "milkshake" mixer. The cup is mounted on the stand in such a position that the stirring paddle is not less than 19 mm nor more than 38 mm above the bottom of the dispersion cup. A general view of the stirring apparatus was shown on the right in Figure 9; details of the stirring paddle and dispersion cup construction are indicated in Figure 12. Detailed working drawings for the unit are designated in ASTM procedures; commercially available models already conform to these drawings and require no further modifications.

At full speed, the mixer rotates at approximately 16,000 rpm and creates relatively stable oil-water emulsions which demulsify very slowly. The mixer was connected to an electronic speed controller capable of

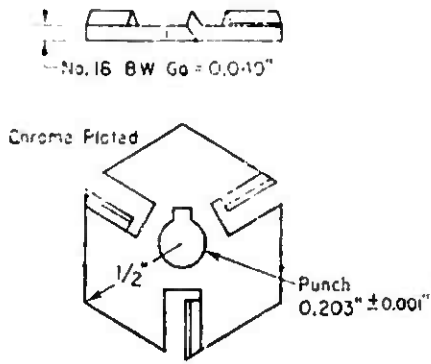

Stirring Paddle

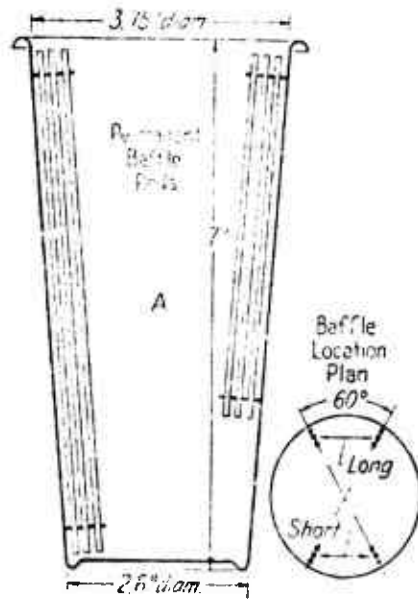

Dispersion Cup

Figure 12. DETAILS OF STIRRING PADDLE AND DISPERSION CUP

regulating its speed within the 4,000 to 8,500 rpm range. By testing various oil-water mixtures, it was found that a stirring speed of 8,000 rpm for 1 or 3 minutes is sufficient for essentially complete dispersion of all the oils tested, with demulsification occurring in a reasonable time for developing the oil separation vs. time curves. These stirring conditions were adapted for subsequent tests.

Demulsification Measurement Procedures

The demulsification measurement unit is designed to be used for:

- (1) Establishing a bilgewater classification scale based on demulsification behavior
- (2) Laboratory preparation of artificial bilgewaters with known properties
- (3) Characterization of actual bilgewaters.

Although the actual demulsification measurement procedures are essentially identical in all three applications, the establishment of the classification scale and the preparation of artificial bilgewaters involve laboratory tests where the desired type and amount of oil are added to water and emulsified by mixing. The characterization of bilgewaters, on the other hand, is a field test where the demulsification behavior of a representative bilgewater sample is measured without knowing either the actual types or concentrations of oils present.

Laboratory Test Procedure

The procedure for measurement of demulsification consists of several steps. First, the measuring stem of a clean and dry demulsification tube is capped and the tube is then clamped to a stand with its opened end up. A premeasured 500-ml volume of water is poured into the mixing cup, which is then clamped in the mixing position on the mixer. The volume of oil required to give a desired concentration is measured with a calibrated microliter syringe and added to the water. Stirring of the mixture is started by pressing the regulating switch of the speed regulator and then continued at 8,000 rpm, typically for 3 minutes. After 3 minutes stirring is discontinued by merely lifting the mixing cup from its retaining clip,

which automatically stops the motor. At this point, the timing stopwatch is reset to zero. The contents of the mixing cup are immediately poured into the inverted demulsification tube. The tube is closed by screwing the driving assembly into the retaining shoulder of the tube, and the entire demulsification assembly is inverted and clamped in its operating vertical position.

Next, the measuring stem is uncapped, and the piston is extended into the tube until the liquid level reaches a "zero" mark located above the shoulder section connecting to the measuring stem. The needle of a syringe which was previously filled with 2.0 ml of heptane is inserted into the top end of the capillary opening of the measuring stem; the syringe is slowly emptied, being careful to allow the heptane to drain slowly on the walls of the capillary and not create plugging. After noting the meniscus of the upper end of the heptane column in the measuring stem, the heptane is lowered below the shoulder of the demulsification tube by retracting the plunger.

During the demulsification process the separating oil rises up and goes into solution with the heptane; the extent of oil separation is followed by making periodic measurements of the volume increase of the heptane-oil solution. To make this measurement, the plunger is driven into the tube forcing the solution into the measuring stem until the emulsion-heptane interface reaches "zero" mark. The level of the upper end of the heptane-oil solution column is read on the stem; the volume of oil separated is indicated by the increase in column height above the initial reading of the pure heptane alone. After reading, the heptane is lowered back below the shoulders of the tube by retracting the plunger.

On completion of the measurements, the demulsification tube is emptied by removing the driver mechanism and draining. To obtain accurate and repeatable results, the tube should be carefully cleaned and dried before reuse. The following procedure was found adequate for obtaining repeatable results: (1) rinse with acetone, (2) wipe the inside of the tube and particularly its shoulders with tissue, (3) clean the measuring stem with a pipe cleaner, (4) repeat the acetone rinse, and (5) air dry.

The boundaries of the liquid heptane column in the measuring tube can be measured within ± 0.05 cm. Since boundaries of both ends of the column have to be measured, the total error in each measurement amounts to ± 0.1 cm of column, or a volume of 0.00507 cm^3 . The reproducibility of the system is good, as illustrated in Figure 13, where results of two repeat measurements obtained with Mobil DTE Heavy Medium hydraulic oil at a concentration of 1,000 ppm in fresh water are compared.

Field Test Procedure

To facilitate the measurements and to obtain reproducible and accurate results, field tests should be performed according to the following step-wise procedure:

(1) Preparation for Measurements

- (a) Clean and dry the demulsification tube. The following cleaning procedure was found adequate: (1) rinse with acetone, (2) wipe the inside of the tube and particularly its shoulders with tissue, (3) clean the measuring stem with pipe cleaner, (4) repeat the acetone rinse, and (5) air dry.
- (b) Cap the measuring stem with a rubber cap.
- (c) Mount the demulsification tube on a stand in a vertical position with its open end up.
- (d) Fill a syringe with 2.0 ml of heptane.
- (e) Set the speed regulator for 8,000 rpm.
- (f) Retract the piston of the driving assembly close to its lowest position.

- (2) Taking Bilgewater Sample - Obtain a premeasured 500-ml volume representative sample of the bilgewater, pour it into the mixing cup, and clamp the cup into mixing position on the mixer. If the temperature of the bilgewater is low, equilibrate until the contents of the cup become warmed to 24°C to 26°C .

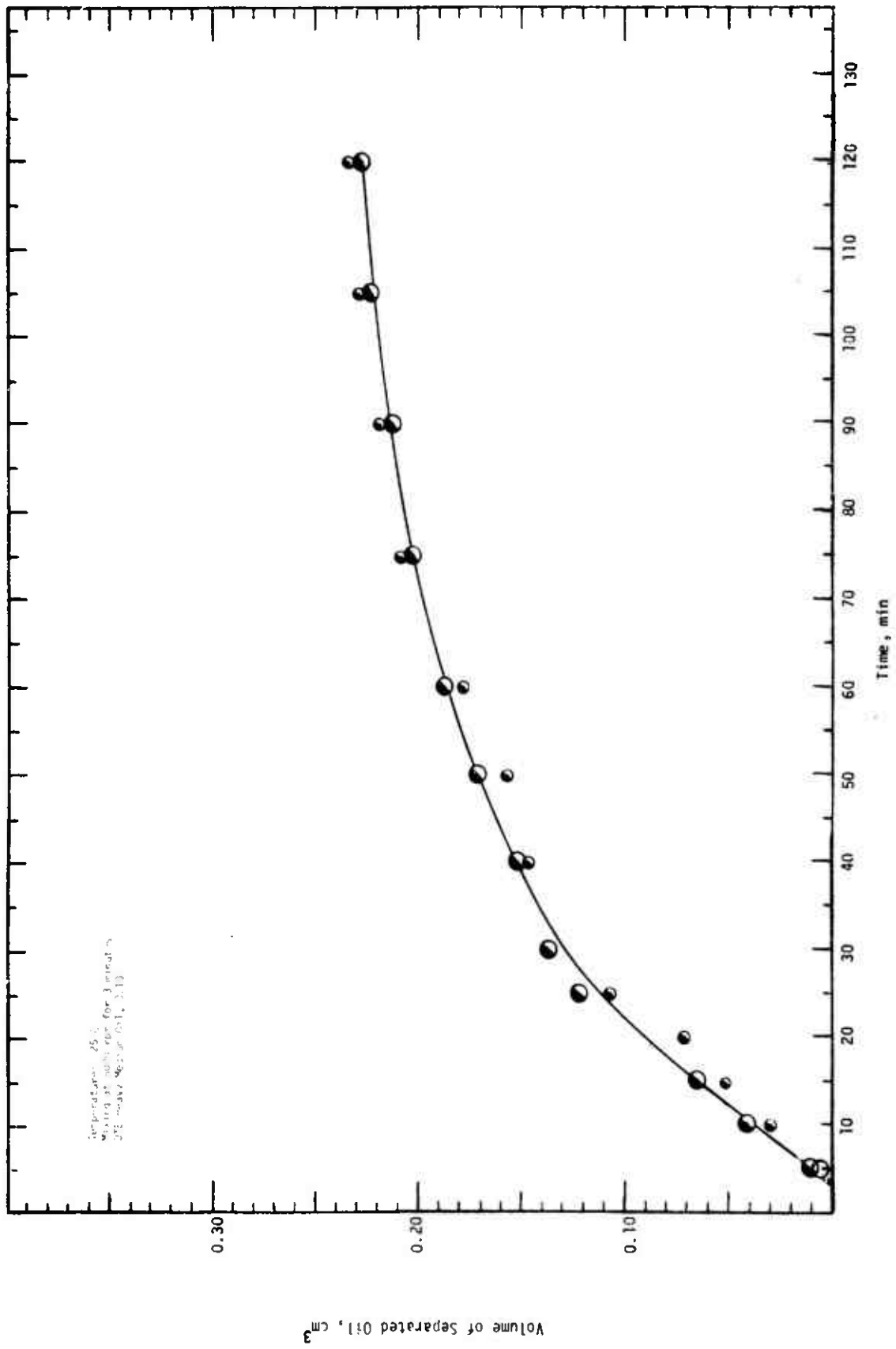

Figure 13. REPRODUCIBILITY OF MEASUREMENTS

(3) Demulsification Tests

- (a) Switch the speed controller on and stir the bilgewater sample at a stirrer speed of 8,000 rpm for 3 minutes (with seawater stir for 1 minute).
- (b) Discontinue stirring by lifting the mixing cup from its retaining clip. At the same time, reset the stopwatch to zero but continue timing.
- (c) Pour the contents of the mixing cup into the demulsification tube.
- (d) Immediately close the demulsification tube by screwing the driving assembly onto the retaining shoulder of the tube; then invert and clamp the entire assembly in its operating vertical position.
- (e) Uncap the measuring stem and extend the piston into the tube until the liquid level reaches a zero mark located below the expanded section of the measuring stem.
- (f) Insert the needle of the syringe into the top end of the capillary opening of the measuring stem and empty the 2.0 ml of heptane slowly and carefully, to avoid plugging.
- (g) Note and record the level of the meniscus of the upper end of the heptane column in the measuring stem.
- (h) Retract the piston until all of the heptane is lowered below the shoulder of the demulsification tube.
- (i) Follow the extent of oil separation by making periodic measurements of the volume increase of the heptane-oil solution. To make this measurement, the piston is driven into the demulsification tube and the solution into the measuring stem until the emulsion-heptane interface reaches zero mark. The level of the upper end of the heptane solution column is read on the stem; the volume of oil separated is indicated by the increase of heptane column height above its initial reading. After reading, lower the heptane below the shoulders of the demulsification tube. It is advisable to make readings at least every 5 minutes during the first 30 minutes, every 10 minutes

during the second 30-minute period, and every 15 minutes thereafter.

- (j) Plot the volume of oil separating (or increase in length of heptane column) vs. time and establish the character of bilgewater by comparing the measured curve with the curves of oil demulsification classification scale.

DEMULSIFICATION CLASSIFICATION SCALE

Initial tests on prepared emulsions using the demulsification measurement instrument indicated that the intrinsic properties of oil and water mixtures appeared to be reflected in their emulsification/demulsification behavior, and that bilgewaters composed of different types of oil mixtures and water lend themselves to classification by experimentally determining their demulsification behavior. Comprehensive demulsification tests were performed using the measurement instrument to classify prepared oil-water emulsions at oil concentrations typically found in bilgewaters. The demulsification properties of the emulsions tested were found to differ sufficiently to serve as indicators of the behavior of selected oil-water mixtures, and to form an empirical bilgewater classification scale.

Demulsification Tests

Demulsification tests were performed on a series of four oils and three types of water using identical procedures and conditions for each test. A measured volume of oil in the 0.05% to 0.15% concentration range typical for bilgewater was added to 500 ml of water and mixed for 1 or 3 minutes at a speed of 8,000 rpm. The mixture was transferred to the demulsification tube, and the volume of separated oil was measured periodically for at least 2 hours. Mixing and demulsification tests were conducted at room temperatures ranging from 24°C to 26°C with the water and oil at temperatures also in this range.

Oil Types

Four oils were selected representing general types used on diesel-powered marine vessels and anticipated in bilgewaters. The oils tested and their essential properties are listed in Table 2. Because of availability, but also for consistency, all the oils were obtained from the Mobil Oil Company. Each oil was tested at three concentrations, namely 0.05%, 0.10%, and 0.15% by volume.

TABLE 2
OILS USED FOR DEMULSIFICATION TESTS

Type	Use	Gravity, Degree API	Viscosity, Centistokes at 100°F	Pour Point, °F (maximum)	Remarks
DTE Heavy Medium	Hydraulic	29.5	63-64	20	Contains antiwear and detergent additives.
Mobilgard 445	Lubricating	24.0	203	10	Contains detergents, antioxidants, dispersants; highly alkaline. Equivalent to MIL-Sym-bol 9250.
Rubrex 200	Lubricating	30.6	43.1	20	Paraffinic oil containing no additives.
Diesel Fuel Oil	Fuel	35.0	4-6		Typical of fuel oil used by marine vessels.

Water Types

Three types of water--deionized, Lake Michigan, and artificial salt-water containing 3% NaCl--were used. The behavior of oils in freshwaters is virtually identical regardless of their source. The emulsions produced in saltwater by the standard mixing procedure, i.e., paddle speed of 8,000 rpm for 3 minutes, were too stable for observing oil separation. Invariably, such mixtures resulted in some initial oil separation lasting for several minutes, directly followed by a period with no observable changes in 2-3 hours. Reducing the mixing time to one minute produced demulsification curves in saltwater similar to those for fresh waters after 3 minutes of mixing.

Experimental Results

The results of the experimental tests are shown in Tables 3-6 for freshwater and Table 7 for saltwater; the amounts of oil separated from emulsion were measured in terms of length of the measuring stem column. Since all the measurements were made using measuring stems having the same bore of 0.254 cm, the observed column length is directly proportional to separated oil volume. A conversion to volume is obtained by multiplying the column length by the cross-sectional area of the measuring stem bore, i.e., 0.0507 cm².

Experimentally observed amounts of oil separated with time for each individual oil tested are presented in Figures 14-17. A common notation for each oil and each concentration, explained in Table 8, was used for all the figures. Demulsifications of different oils from mixtures containing identical oil concentrations are compared in Figures 18-21. As shown in Figures 14-16, the hydraulic and lubricating oils exhibit very well-defined oil separation vs time curves regardless of oil concentration; however, as shown in Figure 17, the curves for diesel fuel are not that well defined and indicate no separation at all for a certain initial time period that increases with a decrease in oil concentration.

During tests, the timer used to monitor oil separation was started immediately after emulsification mixing stopped. Approximately 25 to 60 seconds are required for pouring the oil-water mixture into the demulsification tube, closing it, and inverting to its measuring position. During this time, the oil particles move in the wrong direction and,

TABLE 3
DEMULSIFICATION OF DTE HEAVY MEDIUM OIL*

Time, Minutes	Oil Separated, cm of measuring stem			Volume of oil separated, cm ³			
	0.15%	0.10%	0.10%**	0.05%	0.15%	0.10%**	0.05%
5	---	0.2	0.1	0.1	---	.0101	.0051
10	1.2	0.8	0.6	0.2	.0608	.0406	.0304
15	2.0	1.3	1.0	---	.1014	.0659	.0507
20	3.2	---	1.4	0.6	.1622	---	.0710
25	4.0	2.4	2.1	0.7	.2028	.1217	.1065
30	4.5	2.7	---	0.9	.2282	.1369	---
40	5.4	3.0	2.9	1.0	.2738	.1521	.1470
50	5.8	3.4	3.1	1.1	.2941	.1724	.1572
60	6.1	3.7	3.5	1.2	.3093	.1876	.1775
75	6.6	4.0	4.1	---	.3346	.2028	.2078
90	6.8	4.2	4.3	1.3	.3448	.2129	.2180
105	7.0	4.4	4.5	---	.49	.2231	.2280
120	7.2	4.5	4.6	1.4	.3650	.2282	.2332
135	7.3	---	---	---	.3701	---	---

*Conditions: Temperature 24°-26°C; mixing at 8,000 rpm for 3 minutes

**Duplicate run

TABLE 4
OEMULSIFICATION OF MOBILGARD 445 OIL*

Time, minutes	Oil separated, cm of measuring stem			Volume of oil separated, cm ³		
	0.15%	0.10%	0.05%	0.15%	0.10%	0.05%
5	1.9	0.7	0.6	.0963	.0355	.0304
10	3.1	1.9	1.1	.1572	.0963	.0558
15	3.8	3.0	1.3	.1927	.1521	.0659
20	4.2	3.2	1.5	.2129	.1622	.0760
25	4.6	3.6	---	.2332	.1825	---
30	4.9	3.7	1.7	.2484	.1876	.0862
40	5.1	3.9	1.8	.2586	.1977	.0913
50	5.2	4.1	1.9	.2636	.2079	.0963
60	5.3	4.2	2.0	.2687	.2129	.1014
75	5.4	4.3	2.1	.2738	.2180	.1065
90	5.5	4.3	2.1	.2788	.2180	.1065
105	5.7	4.4	2.2	.2890	.2231	.1115
120	5.5	4.4	2.2	.2788	.2231	.1115

*Conditions: Temperature 24°-26°C; mixing at 8,000 rpm for 3 minutes

TABLE 5
DEMULSIFICATION OF RUBREX 200 OIL*

Time, minutes	Oil separated, cm of measuring stem			Volume of oil separated, cm ³		
	0.15%	0.10%	0.05%	0.15%	0.10%	0.05%
5	0.4	0.2	0.1	.0203	.0101	.0051
10	1.3	0.5	0.2	.0659	.0254	.0101
15	2.0	0.8	0.3	.1014	.0406	.0152
20	---	1.1	0.4	.0558	.0203	.0203
25	3.3	1.5	0.5	.1673	.0760	.0254
30	3.6	1.6	0.6	.1825	.0811	.0304
40	3.9	1.9	0.7	.1977	.0963	.0355
50	4.4	2.2	0.8	.2231	.1115	.0406
60	4.6	2.4	0.9	.2332	.1217	.0456
75	4.9	2.7	1.0	.2484	.1369	.0507
90	5.0	3.0	1.1	.2535	.1521	.0558
105	5.2	3.1	1.2	.2636	.1572	.0608
120	5.2	3.2	1.2	.2636	.1622	.0608

*Conditions: Temperature 24°-26°C; mixing at 8,000 rpm for 3 minutes

TABLE 6
DEMULSIFICATION OF DIESEL FUEL OIL*

Time, minutes,	Oil Separated, cm of Measuring Stem			Volume of Oil Separated, cm ³		
	0.15%	0.10%	0.05%	0.15%	0.10%	0.05%
5	-0-	-0-	-0-	-0-	-0-	-0-
10	0.1	0.1	-0-	.0051	.0051	-0-
15	0.2	0.1	-0-	.0101	.0051	-0-
20	0.5	0.2	-0-	.0254	.0101	-0-
25	0.8	---	-0-	.0406	---	-0-
30	1.1	0.4	-0-	.0558	.0203	---
40	1.4	0.9	-0-	.0710	.0456	-0-
50	1.8	0.8	0.1	.0913	.0406	.0051
60	1.9	1.0	0.1	.0963	.0507	.0051
75	2.4	1.3	0.2	.1217	.0659	.0101
90	2.9	1.5	0.2	.1470	.0760	.0101
105	3.3	---	0.2	.1673	---	.0101
120	3.5	1.8	0.2	.1774	.0913	.0101
135	3.7	---	---	.1876	---	---
150	3.9	2.1	---	.1977	.1065	---
165	---	---	---	---	---	---
180	4.3	2.3	0.3	.2180	.1166	.0152

Conditions: Temperature 24°-26°C; mixing at 8,000 rpm for 3 minutes

TABLE 7
DEMULSIFICATION OF OILS IN SALTWATER

Time, minutes	Oil Separated*, cm of Measuring Stem				Volume of Oil Separated* cm ³			
	DTE Heavy Medium	Mobilgard 445	Rubrex 200	Diesel Fuel	OTE Heavy Medium	Mobilgard 445	Rubrex 200	Diesel Fuel
5	0.7	1.3	0.3	0.1	.0355	.0660	.0152	.0051
10	1.2	2.0	1.0	0.2	.0608	.1014	.0507	.0101
15	1.7	2.3	1.3	0.3	.0862	.1166	.0659	.0152
20	2.1	2.4	1.6	0.6	.1065	.1217	.0811	.0304
25	2.6	---	1.7	---	.1318	---	.0862	---
30	2.9	2.6	1.9	0.8	.1470	.1318	.0963	.0406
40	3.0	---	2.1	0.9	.1521	---	.1065	.0456
50	3.3	---	2.5	1.2	.1673	---	.1268	.0608
60	3.4	2.6	2.7	1.3	.1724	.1318	.1369	.0659
75	3.5	---	3.0	1.4	.1774	---	.1521	.0710
90	3.5	---	3.2	---	.1774	---	.1622	---
105	3.5	---	3.3	1.4	.1774	---	.1673	.0710
120	---	---	3.3	---	---	---	.1673	---

* Mixing at 8,000 rpm for 1 minute; oil concentration 0.10%; 3% NaCl solution; temperature 24°-26°C

TABLE 8
LEGEND FOR DEMULSIFICATION FIGURES

Oil	0.15%	0.10%	0.05%
DTE Heavy Medium	●	◐	○
Mobilgard 445	▲	◐▲	△
Rubrex 200	■	◐■	□
Diesel Fuel Oil	●	◐	○
Freshwater	—————		
Saltwater	- - - - -		

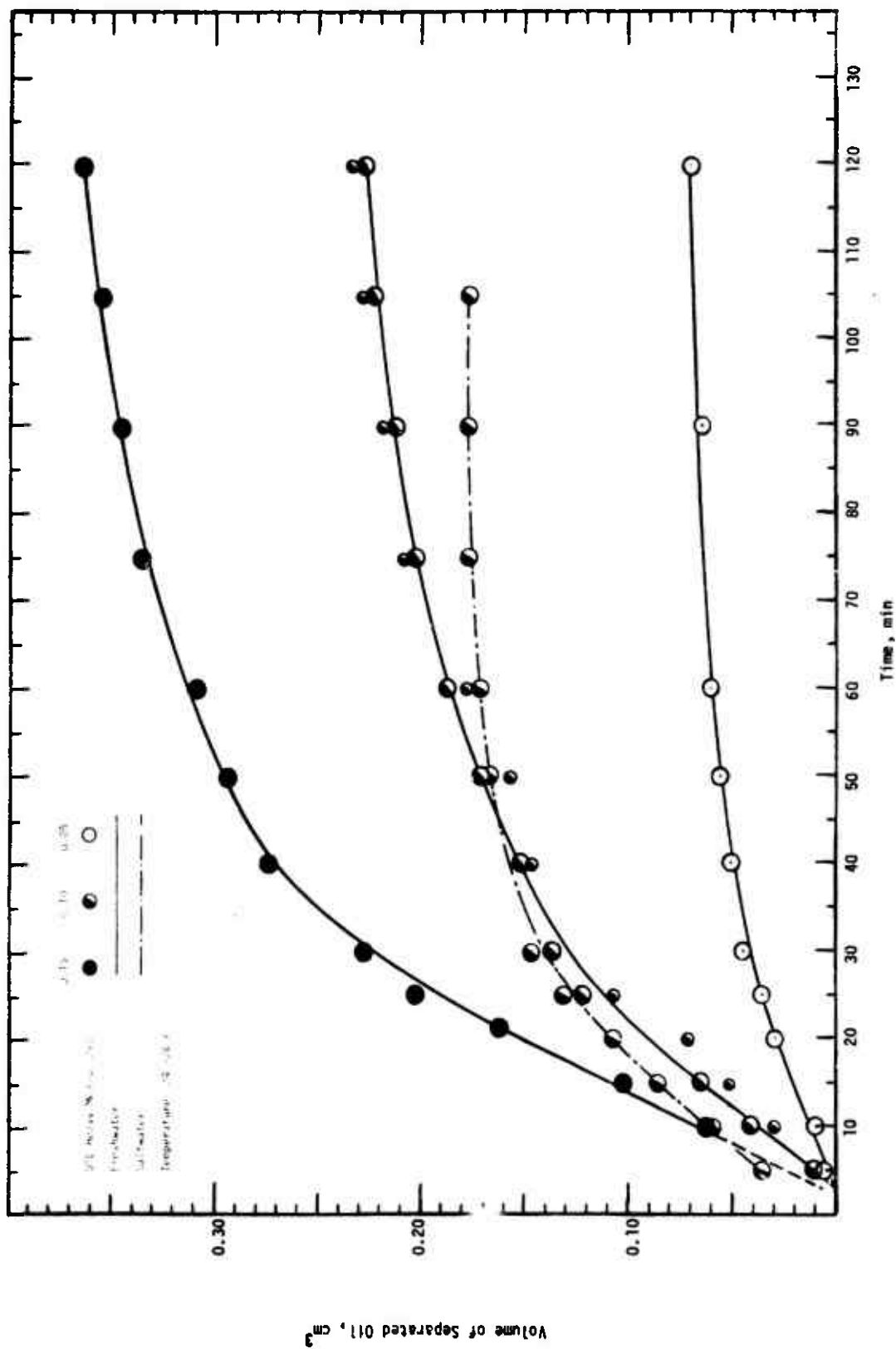

Figure 14. DEMULSIFICATION OF DTE HEAVY MEDIUM OIL

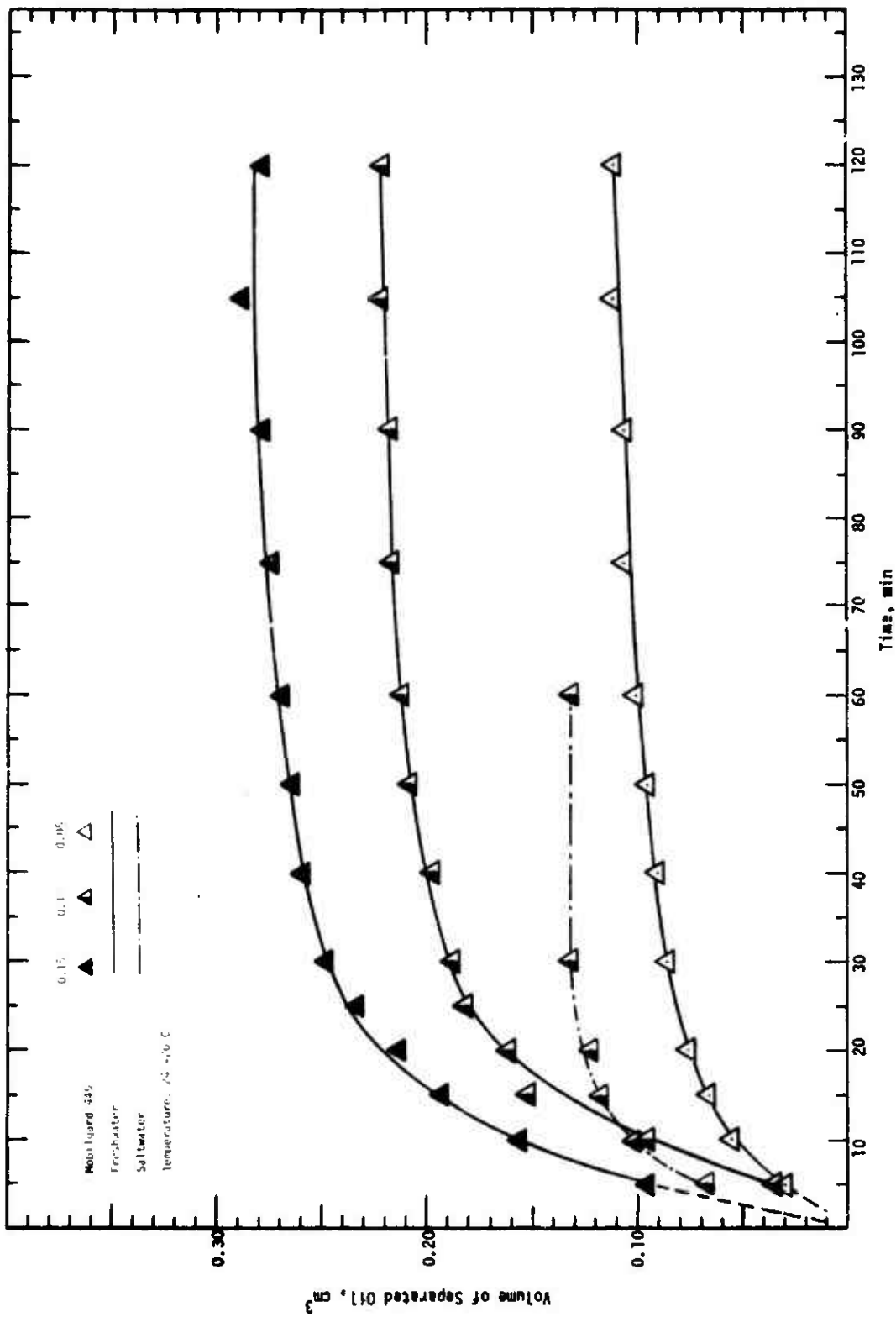

Figure 15. DEMULSIFICATION OF MOBILGARD 445 OIL

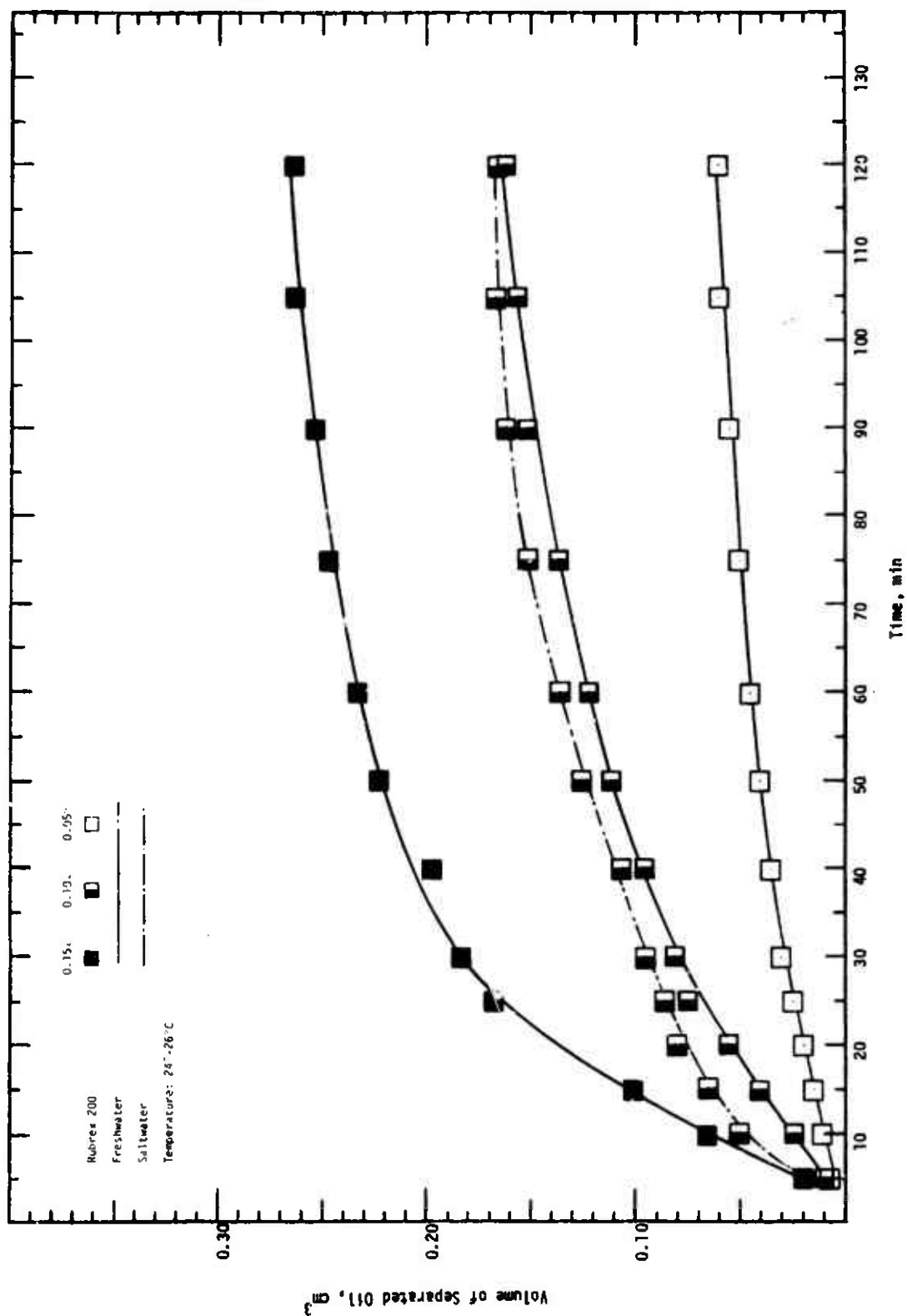

Figure 1b. DEMULSIFICATION OF RUBREX 200 OIL

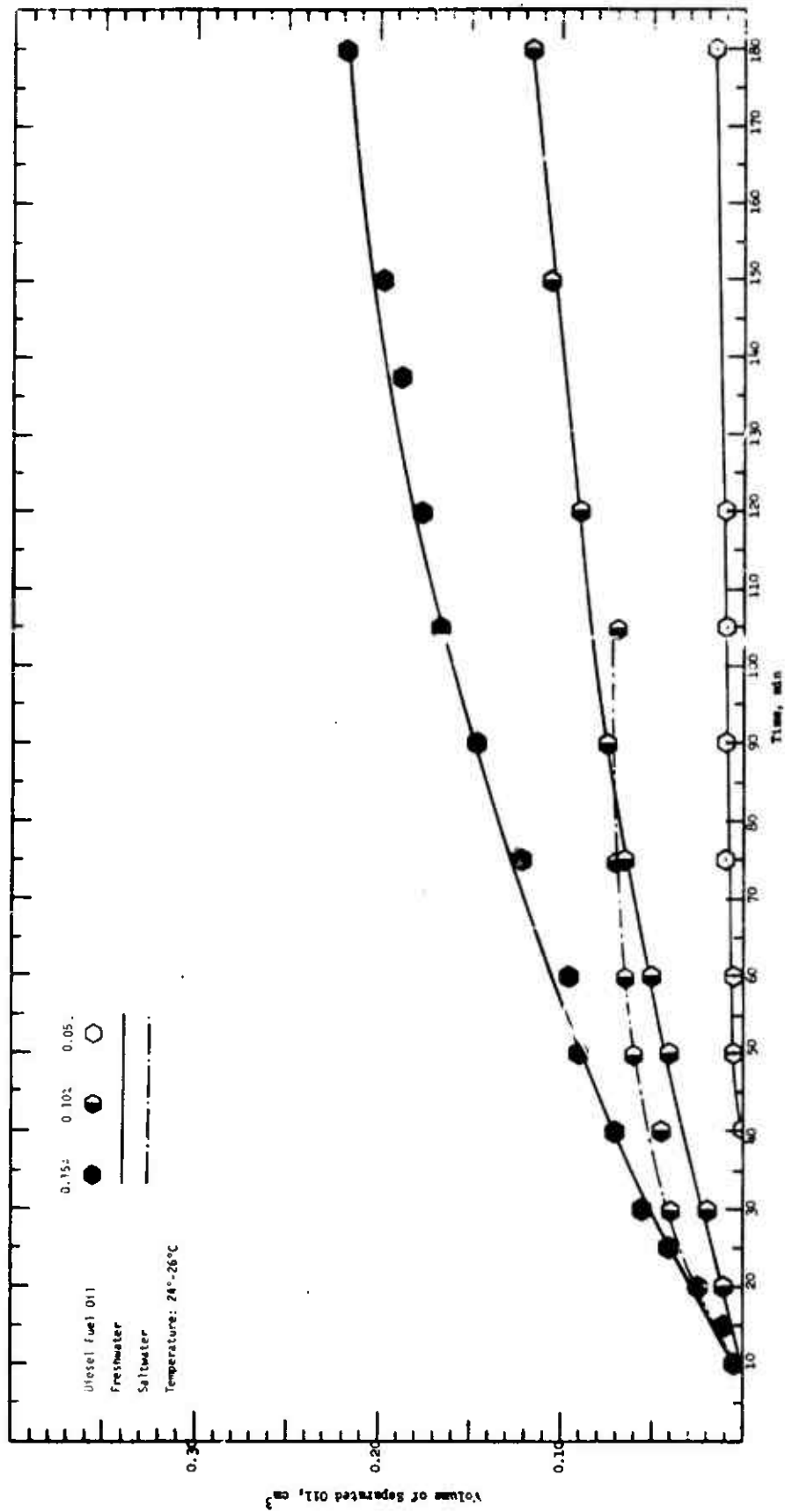

Figure 17. DEMULSIFICATION OF DIESEL FUEL OIL

on inverting the tube to its measuring position, some time is required for oil particles to move back to their original position. For this reason, there is an inherent lag in the time measurement amounting to up to about 2 minutes, and most of the measurements made after the first five minutes tend to be low. Recognizing this, it appeared that a better representation of the demulsification behavior of oils is obtained where the separation vs. time curves are started at the 5-minute reading instead of starting at the origin. This procedure was used for the data in Figures 14-21.

Separation of oil from oil-water dispersions and/or emulsions occurred in three distinct phases, of which the first and second are depicted in the curves. The first phase comprises the initial separation following the cessation of mixing when oil separates relatively quickly. Thus, a plot of separated oil volume vs. time results in an essentially straight line. This behavior is presumably due to the relatively large oil particles dispersed in water which rise to the surface during the first phase of separation. The observed slopes of the initial separation depend both on oil type and concentration. There is, however, a possible correlation between the length of the first phase and the density of oil. Regardless of oil concentration, the first phase of separation is completed sooner for heavier oils and lasts for a longer time for lighter oils.

The second phase of oil separation results in a curved line approaching asymptotic values after approximately 2 hours. Apparently, the emulsified oil particles are small and must coalesce to float to the surface. It is generally recognized that the coalescence of emulsified particles follows the binary collision approximation and is proportional to the square of the number of particles. Thus, the relation results in a curved line for oil separation versus time.

The separation of oil during the third phase is extremely slow, probably requiring 5-10 days for achieving essentially complete separation. Obviously, this phase represents a very stable mechanical or chemical emulsion. Measurements of oil separation during this third phase are impractical for developing the general classification scale and were not made during this study.

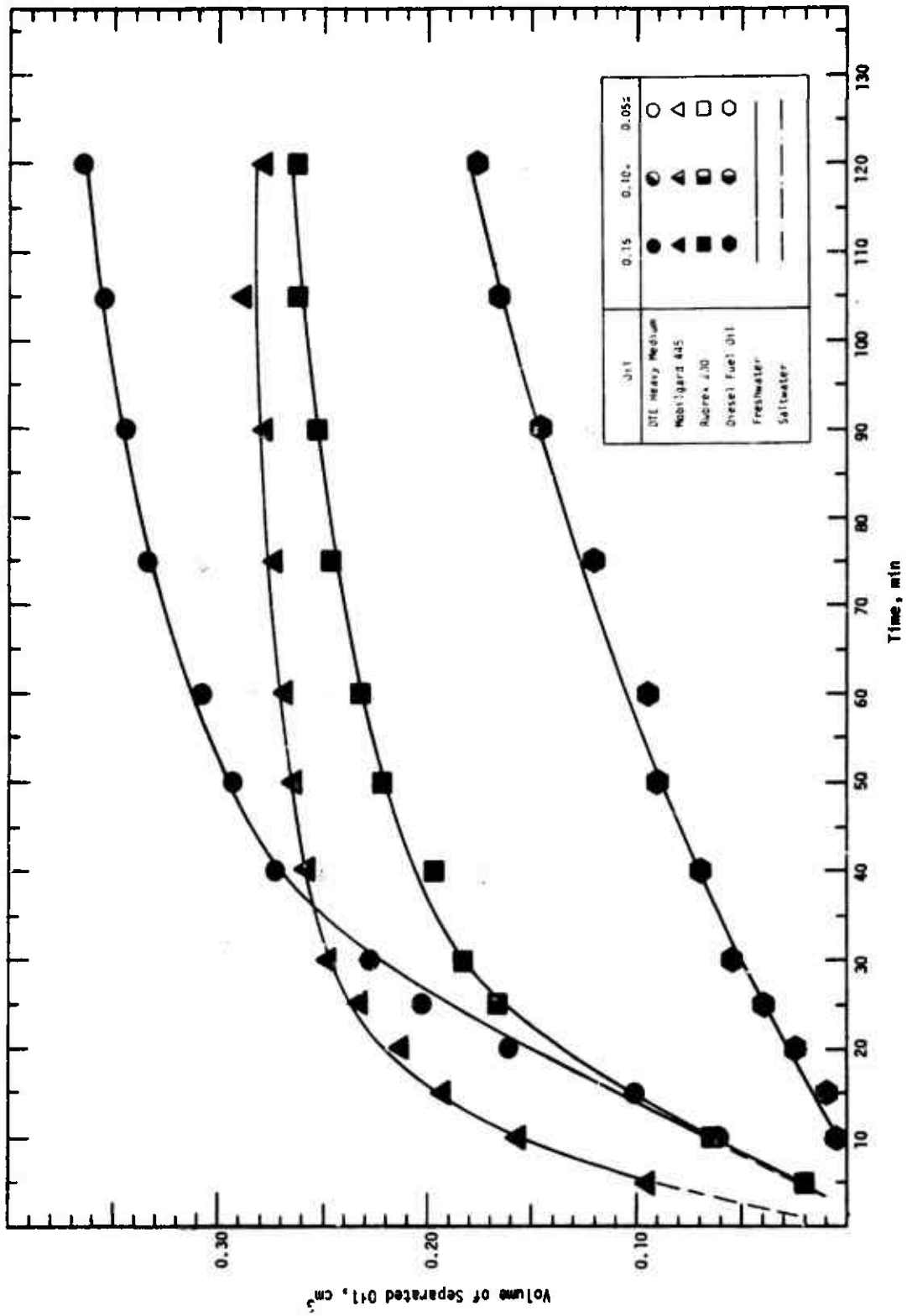

Figure 18. DEMULSIFICATION FROM MIXTURES CONTAINING 0.15% OIL

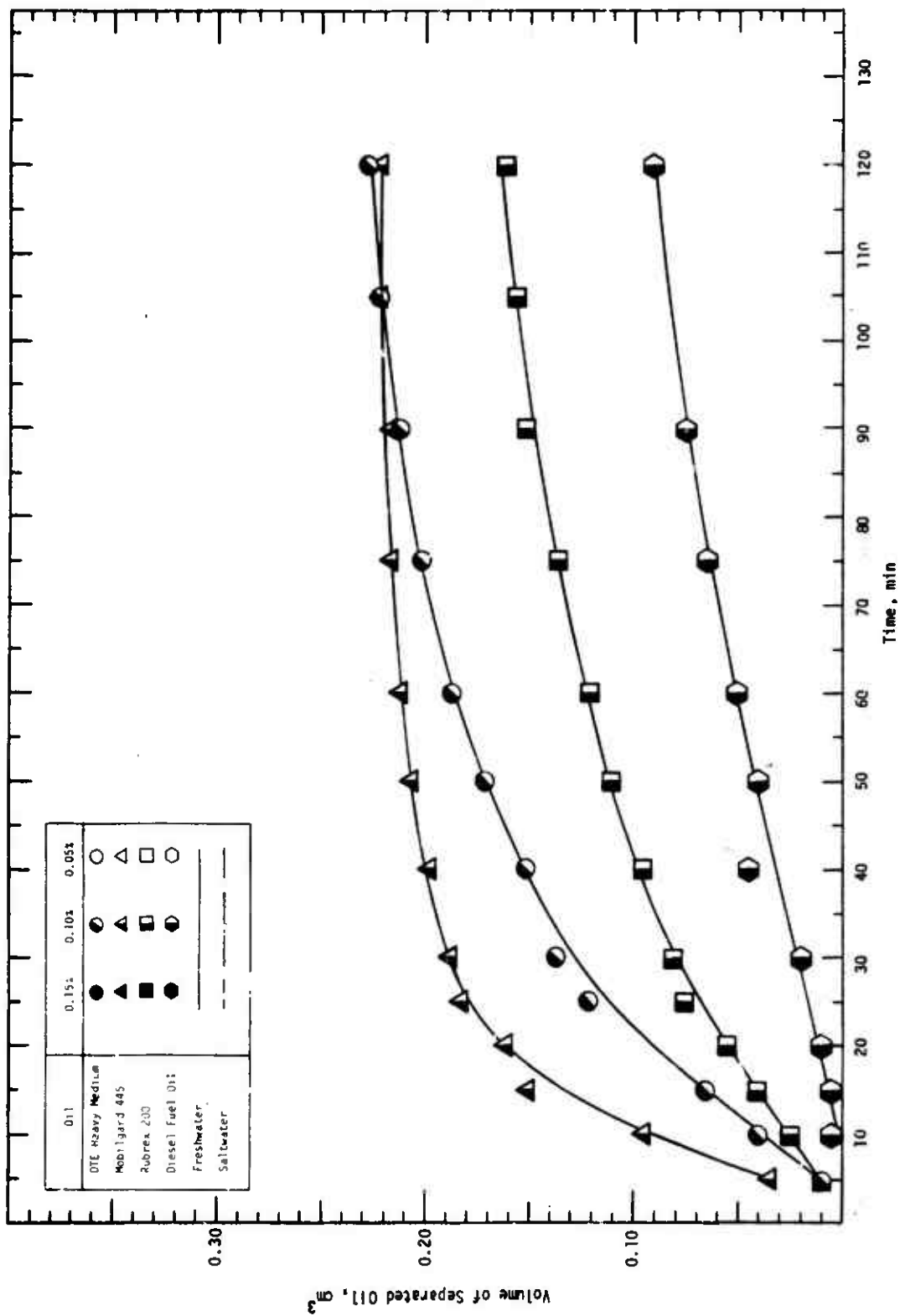

Figure 19. DEMULSIFICATION FROM MIXTURES CONTAINING 0.10% OIL IN FRESHWATER

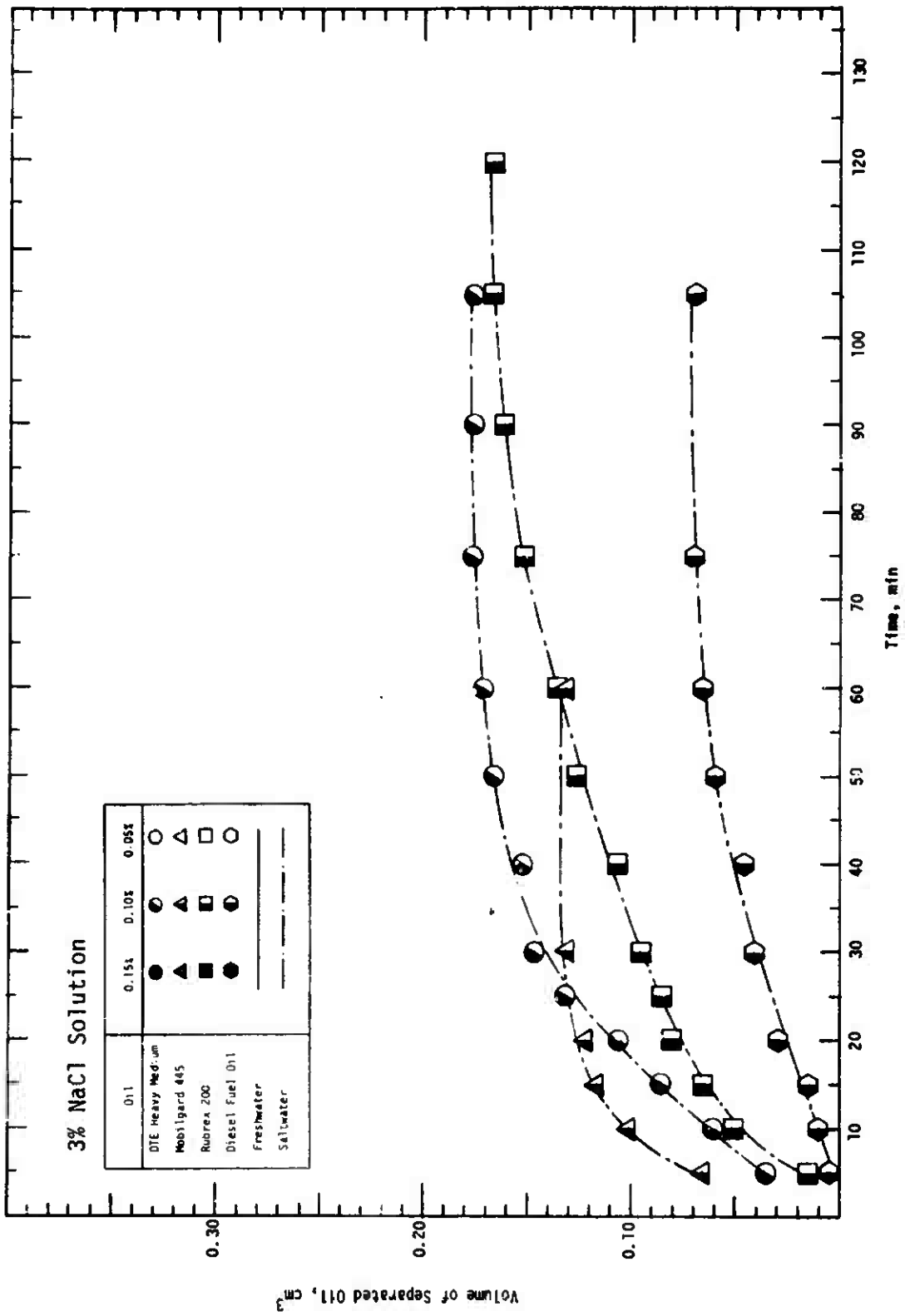

Figure 20. DEMULSIFICATION FROM MIXTURES CONTAINING 0.10% OIL IN SALTWATER

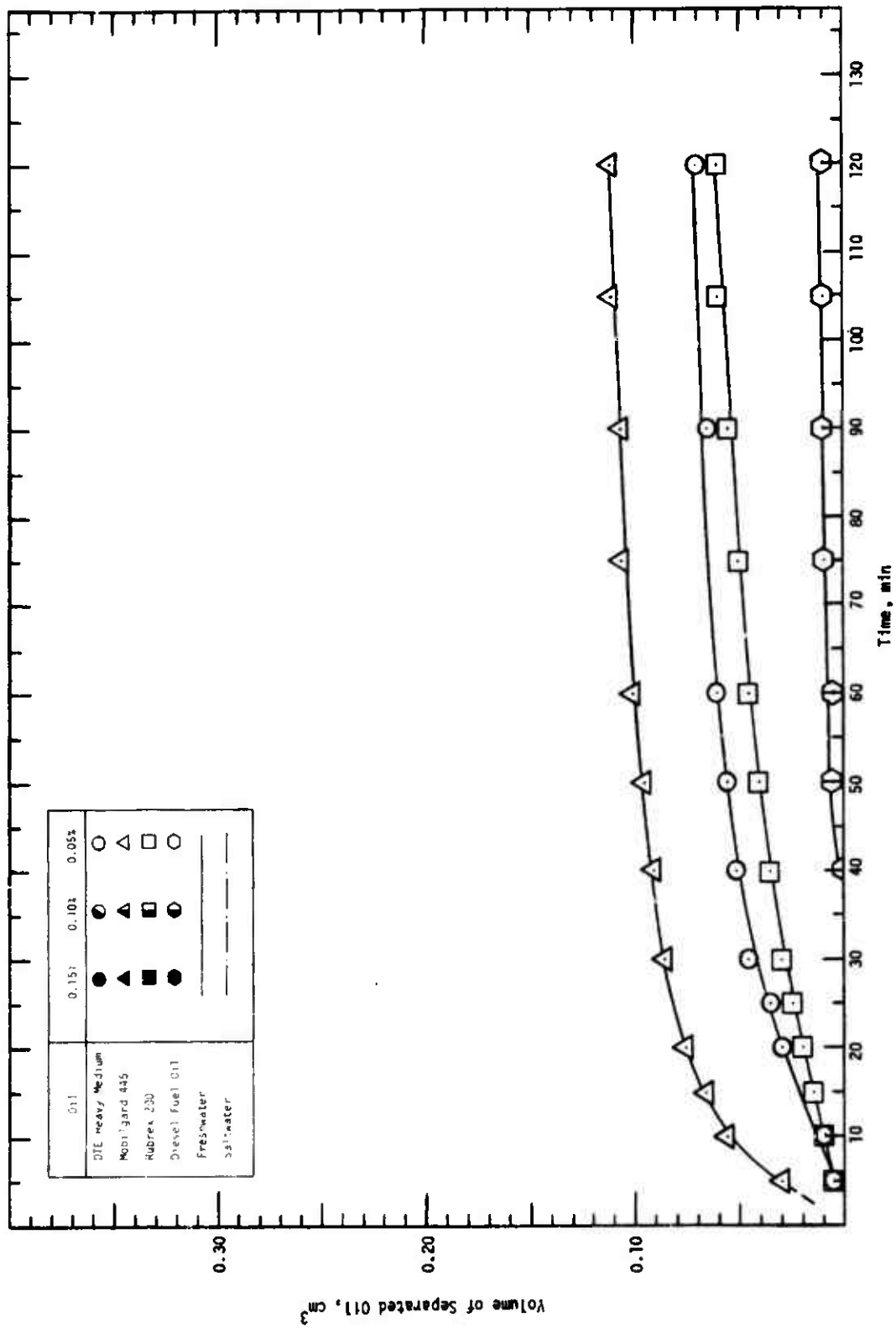

Figure 21. DEMULSIFICATION FROM MIXTURES CONTAINING 0.05% OIL

Classification Scale

Figure 22 presents the classification scale in total; the scale is the summary of the demulsification behavior of all the emulsions tested under varied combinations of oil type and concentration, water type, and emulsion mixing procedure.

The amount of oil separated in a given time, or the overall shape of the generated demulsification curve for a given emulsion, does not lead to a specific identification of the initial oil concentration or oil type. However, characterization of an emulsion with respect to general behavior in a physical-mechanical oil-separation device can be estimated from the classification curves. The essential characterization parameter is directly correlated to the relative amount of oil separated over a given time, as depicted on the classification curve.

Interpretation of Classification Scale

The characteristic volume-time curves for the prepared emulsions tested broadly fell into two types: Type A exhibits two distinct parts in the curve, namely a steep Phase I section indicating relatively rapid separation of oil; Type B exhibits no distinct or abruptly changing parts in the curve, indicating only a gradually slowing rate of oil separation.

The Type A curves group into a family occupying approximately the upper half of the classification scale, while the Type B curves occupy approximately the lower half, although some overlapping does exist. The emulsions in the Type A family are those containing hydraulic and lubricating oils in concentrations of 0.10% and 0.15%

The shapes of the curves depicting the first and second phases of oil separation vs. time show general similarity for emulsions that were formed under controlled mixing conditions. For the standard 500-ml total volume of emulsion tested, the volume of oil separating during the two time phases does not directly correlate to either the type or initial concentration of oil in the emulsion. However, the characteristic curves do directly indicate the general ability of oil to separate from a specifically prepared emulsion at rest and under the influence of gravity. Thus, by referring to the family of curves in the classification scale, the behavioral characteristics of an emulsion can be classified even though the type and concentration of oil in the emulsion are not known.

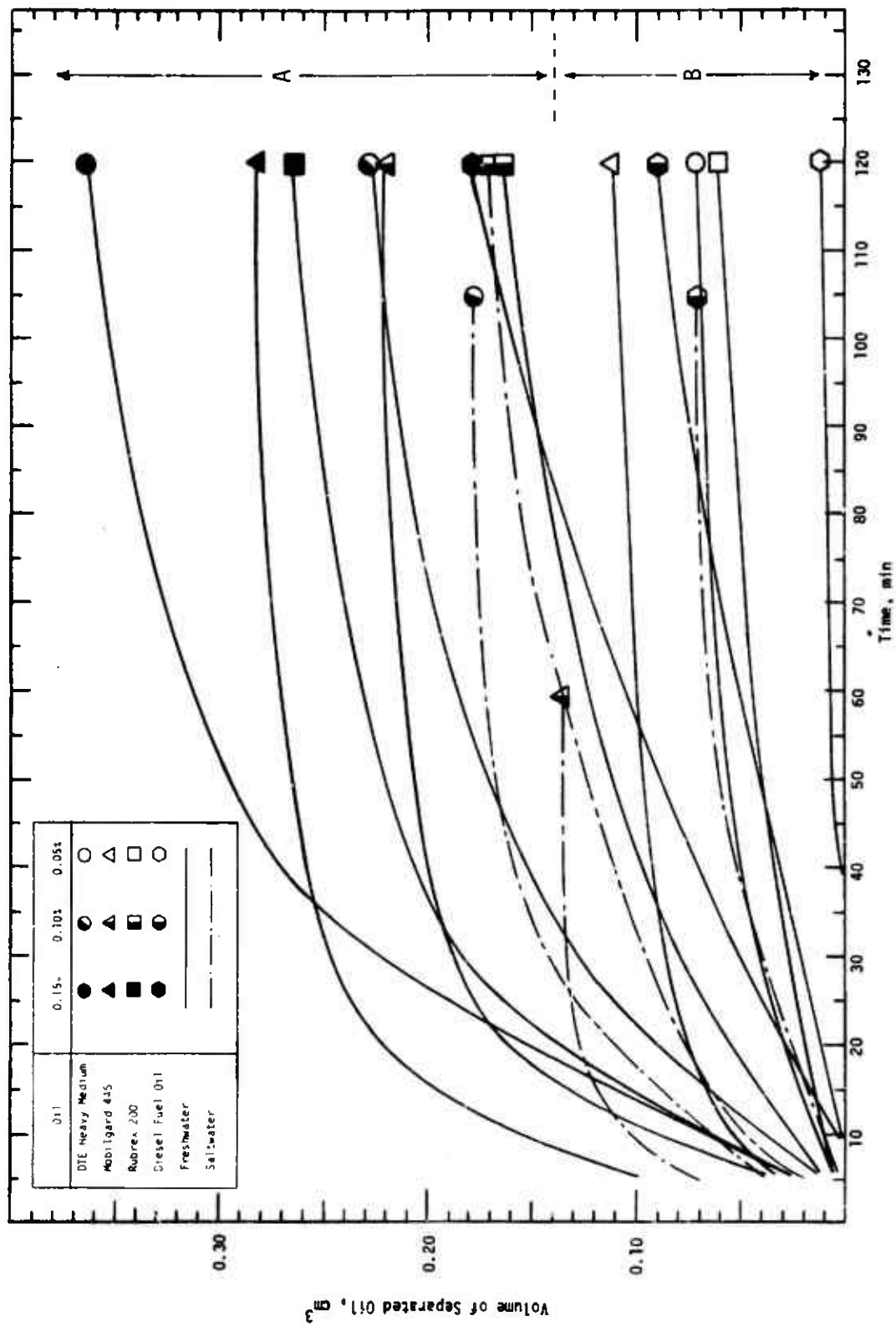

Figure 22. OIL DEMULSIFICATION CLASSIFICATION SCALE

The emulsions of the Type B family are created from hydraulic and lubricating oils at concentrations of 0.05%, and diesel oil at concentrations of 0.05%, 0.10%, and 0.15% by volume.

In all instances, the oil separated out more rapidly for higher initial oil concentrations with the same oil. In addition, at equivalent oil concentrations, the hydraulic and lubricating oils separated out more rapidly than diesel oil.

The above generalizations apply to emulsions prepared with both fresh water and a 3% NaCl saltwater. However, the emulsions prepared with fresh water were mixed for 3 minutes, while those with salt water were mixed for only 1 minute. As noted previously, preparing oil and saltwater emulsions with mixing for 3 minutes resulted in characteristic demulsification curves with either no discernible oil separation, or initial minor amounts (0.01 to 0.05 cm³) of oil separating.

The characteristic curves shown in Figure 22 are specifically dependent on the emulsification history for a given emulsion sample. Energy input during emulsification distinctly affects the resulting demulsification characteristic curve. The mixing time and mixer speed combine to produce the total energy input during preparation of the emulsions. If the energy input is too low, some oil will remain as a separate phase, and the oil concentration in the emulsion will be lower than anticipated, resulting in an inaccurate characteristic curve. If the energy input is too high, the emulsion formed may be too stable to provide a meaningful demulsification curve in the nominal two-hour testing period.

Application of Classification Scale to Bilgewaters

The classification scale can be used to measure the characteristics of a specific bilgewater emulsion by subjecting a representative sample of the bilgewater to the mixing and demulsification measurement procedures used in developing the curves shown in the classification scale. Briefly, the sample should be mixed for 1 or 3 minutes, for salt or fresh water, respectively, using the mixer assembly and then transferred to the demulsification measurement instrument to observe the amount of oil separated during a two-hour period, employing field test procedures described in an earlier section.

The characterization of the bilgewater is made by superimposing the experimentally observed demulsification, i.e., volume of separating oil vs. time, curve on the classification scale. Although typical bilgewaters will rarely contain one type of oil, the position of the observed demulsification curve on classification scale will indicate that the combined demulsification character of oils present in bilgewater can be represented and is identical to some oil type and concentration used in establishing the classification scale. Combined with the shape of the demulsification curve, the volume of oil separated after two hours, i.e., position of the classification scale, will also serve to indicate the approximate oil concentration present in bilgewater. For instance, demulsification measurements of a bilgewater sample resulted in 0.225 cm³ oil separated after 2 hours. Comparing this separated oil volume with the values presented in Figure 22, it can be concluded that the oil concentration in the bilgewater sample is approximately 0.10%; however, the demulsification character of this bilgewater can be represented either by DTE Heavy Medium or Mobilgard 445 oils, depending on the shape of the entire demulsification curve. If the initial oil separation, i.e., Phase I, produced a nearly straight line for 10 minutes, followed by a curved line (Phase II) the bilgewater could be represented by Mobilgard 445 oil. On the other hand, if the straight line of Phase I separation continued for 20 minutes, the bilgewater oil could be represented by DTE Heavy Medium Oil.

Application for the Preparation of Artificial Bilgewaters

When a classification curve has been delineated for a given bilgewater sample, the probable behavior of the bilgewater in a specific oil separation system can be estimated by relating it to the behavior of an artificial bilgewater. The estimate can be generated either from prior data compiled in tests of the system with prepared known emulsions, i.e., artificial bilgewaters, or a sample emulsion with a classification curve similar to that for the bilgewater sample can be prepared and tested in a given oil separation system.

The classification scale developed is suitable for characterizing emulsions that are effectively separated by physical-mechanical processes. Emulsions that have been stabilized by chemical additives or high energy

inputs are generally not amenable to oil separation by mechanical processing. These emulsions will not be characterized by developing artificial bilgewater and applying the techniques used to develop the classification scale.

The classification curve developed for the bilgewater sample can be used to give an overall indication of how the bilgewater emulsion will behave in an oil removal system, assuming that the bilgewater enters the removal system under the same conditions existing where and when the bilgewater sample was taken. If the collected sample differs markedly from the bilgewater actually entering the removal system, no correlation will be made.

CONCLUSIONS AND RECOMMENDATIONS

The conclusions and recommendations presented in this section are based on observations and data generated during development and evaluation tests. All tests were conducted at General American Research Division facilities.

Conclusions

(1) The ASTM D 1401-67, "Standard Method of Test for Emulsion Characteristics of Petroleum Oils and Synthetic Fluids", procedure and apparatus in unmodified form were found unsuitable for classifying bilgewaters according to their demulsification characteristics. The prescribed mixing speed, time, and equipment configuration were not adequate to completely disperse the oil phase for the low oil concentrations typical of bilgewaters.

(2) A simple, manually-operated demulsification measuring instrument, based on modified ASTM D 1401-67 procedures, ASTM 422-63 mixing equipment, and a GARD-developed demulsification assembly utilizing a capillary measuring tube, was found suitable for characterizing artificial bilgewater emulsions containing oils in the 0.05% to 0.15% volume concentration range.

(3) Measuring the true volume of oil separated during demulsification required collecting coalesced oil droplets in a solvent that was immiscible in water; without a solvent the coalesced oil would adhere inwardly to the tapered walls of the collecting tube, causing large errors and nonreproducible results in oil volume measurements.

(4) The dominant factors affecting the demulsification behavior of prepared oil-water emulsions were found to be oil concentration, input energy during emulsion formation, and salt content of water. Factors found to have a lesser influence on demulsification behavior were temperature and water pH.

Preceding page blank

(5) Of the four oils typical of those used on marine vessels, hydraulic oil was found to separate more rapidly from emulsion than the two lubricating oils, or diesel fuel oils tested; the diesel oil separated more slowly than the others.

(6) For the emulsions tested, oil was found to separate out during three time phases; the rates of separation in Phase I appeared linear for higher concentrations in the 0.10% to 0.15% by volume range for hydraulic and lubricating oil, but not for diesel oil. The amount and rate of oil separation did not appear readily relatable to physical properties of oils, such as their viscosity or specific gravity.

(7) The relationship developed between the volume of oil separated and time, during demulsification of prepared artificial bilgewater emulsions, was determined to be an appropriate basis for development of a classification scale to empirically characterize bilgewater emulsion behavior.

(8) The bilgewater classification scale does not appear sufficiently specific in its present form to be suitable for measuring the concentration of or identifying specific physical or mechanical properties of the oil present. However, with further refinement, the classification appears suitable for determining oil concentration ranges.

(9) The emulsification procedures used to prepare the tested artificial bilgewater emulsions appear suitable and sufficiently reproducible to serve as a basis for generalized preparation of artificial bilgewater emulsions for testing and evaluation of oil separation systems.

Recommendations

(1) The demulsification tube assembly should be mechanically modified to achieve the following objectives:

- (a) Simplify the introduction of the mixed emulsion,
- (b) Eliminate inverting the tube assembly and resultant inaccuracy in timing of oil separation
- (c) Provide for ready draining and flushing after testing without disassembly of drive unit from demulsification tube.

(2) In anticipation of the possible continued use of detergents or other surfactants that increase emulsion stability, the behavior of emulsions containing additives should be investigated, and a classification scale prepared in a manner similar to the one prepared for pure oils and water described in this report.

(3) The present classification scale should be extended to cover the behavior of two or more oils in mixtures with water.

(4) The relationship between the classification scale and mixing energy used in forming an emulsion should be evaluated by experimental tests. Also, a predetermined holding-time prior to classification testing should be established empirically to provide an equivalent starting characteristic for various samples being evaluated. The data so obtained would be expressly useful in more accurately predicting the performance of oil-separating devices that handle emulsions with varied energy input histories.

(5) A specific test series on actual bilgewaters should be conducted in reference to the classification scale to relate performance characteristics of bilgewaters with actual bilgewater composition. If feasible, a relationship should be developed between bilgewater characteristics and shipboard housekeeping practices, in anticipation of effects of additives on these characteristics.